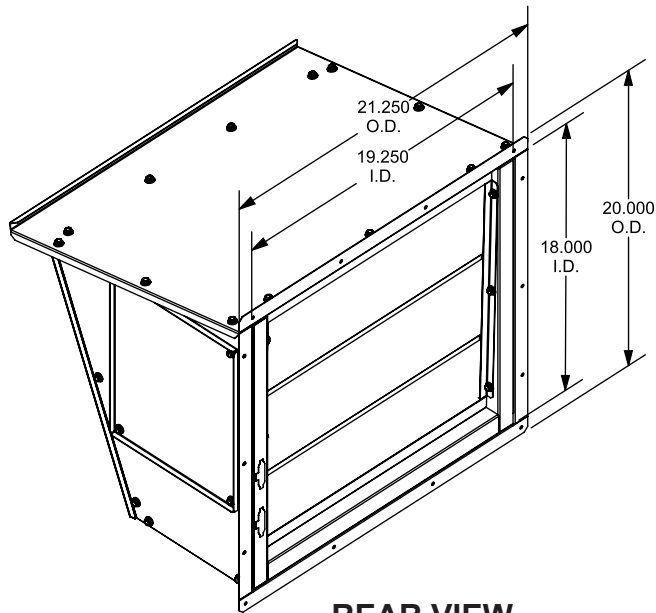
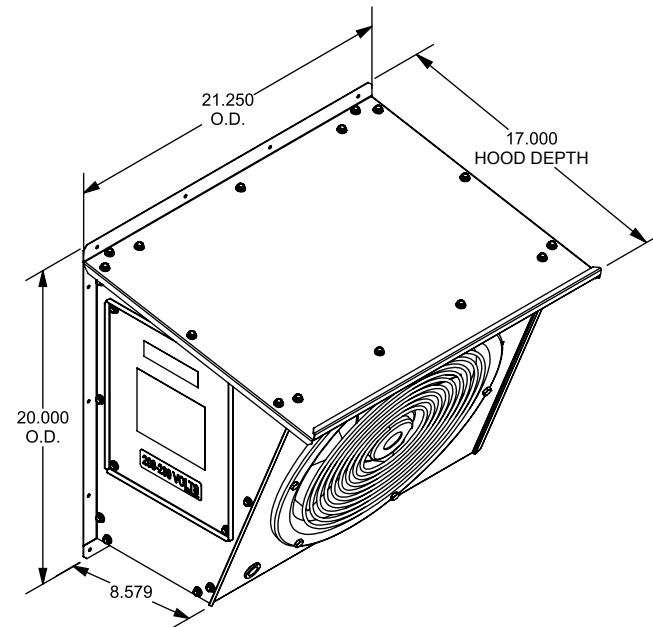

Submitted To:

Job:

Notes:

REAR VIEW

FRONT VIEW
Notes:

1. Kit includes (1) 300mm EBM prop-type fan, mounted in power exhaust housing.
2. Wiring harnesses provided to connect power exhaust to economizer for low voltage and to unit control box for high voltage.
3. Power exhaust housing is constructed of pre-paint steel to match color of rooftop unit.
4. Includes barometric relief damper.
5. Mounts to horizontal duct return duct (field supplied).

Product Operating Weight:

47 Lbs