

**COLOR CODE**

- BK ----- BLACK
- BL ----- BLUE
- BL/PK ----- BLUE/PINK STRIPE
- BR ----- BROWN
- OR ----- ORANGE
- PU ----- PURPLE
- RD ----- RED
- WH ----- WHITE
- YL ----- YELLOW
- YL/PK ----- YELLOW/PINK STRIPE

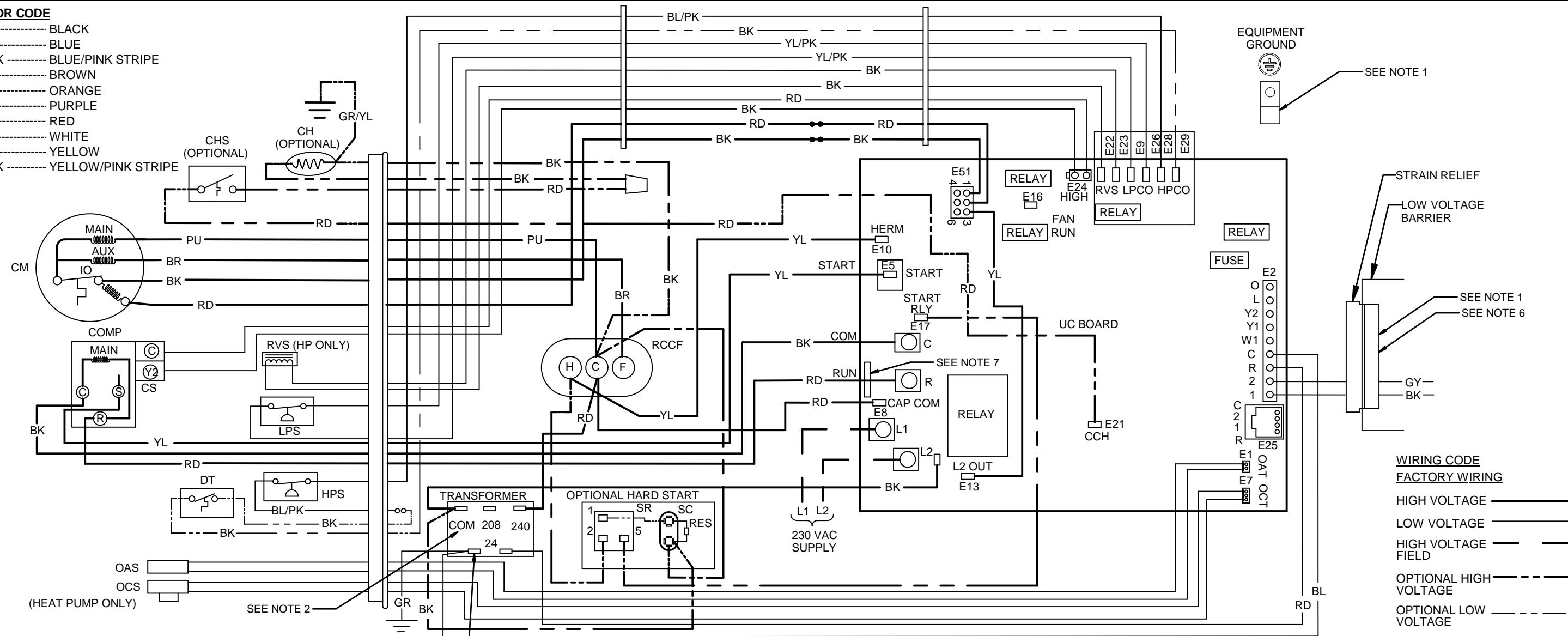

**COMPONENT CODE**

- C ----- CONTACTOR
- CH ----- CRANKCASE HEATER
- CHS ----- CRANKCASE HEATER SWITCH
- CM ----- CONDENSER FAN MOTOR
- COMP ----- COMPRESSOR
- CS ----- COMPRESSOR SOLENOID
- DT ----- DISCHARGE THERMOSTAT
- HPS ----- HIGH PRESSURE SWITCH
- IO ----- INTERNAL OVERLOAD
- LPS ----- LOW PRESSURE SWITCH
- OAS ----- OUTDOOR AIR SENSOR
- OCS ----- OUTDOOR COIL TEMP SENSOR
- RCCF ----- RUN CAPACITOR FOR COMPRESSOR & FAN
- RVS ----- REVERSING VALVE SOLENOID
- SC ----- START CAPACITOR FOR COMPRESSOR (OPTIONAL)
- SR ----- START RELAY FOR COMPRESSOR (OPTIONAL)

**NOTES:**

1. USE COPPER SUPPLY WIRES ONLY.
2. USE 40VA TRANSFORMER MINIMUM FOR SYSTEM
3. IF DT IS NOT PRESENT, HPS BL/PK WIRE GOES DIRECTLY TO TERMINAL E29.
4. CONTROLS SHOWN WITH THERMOSTAT IN "OFF" POSITION.
5. COMMON SIDE OF 24VAC CONTROL CIRCUIT MUST BE GROUNDED.
6. USE N.E.C. CLASS 2 WIRES.
7. COMPRESSOR WIRE TO BE ROUTED THROUGH CENTER OF CURRENT SENSOR BEFORE CONNECTING TO R TERMINAL

