

INSTALLATION INSTRUCTIONS FOR SELF-CONTAINED PACKAGE AIR CONDITIONERS AND HEAT PUMP UNITS

*PCH/*PHH 13.4 SEER2 “H” SERIES WITH R-410A

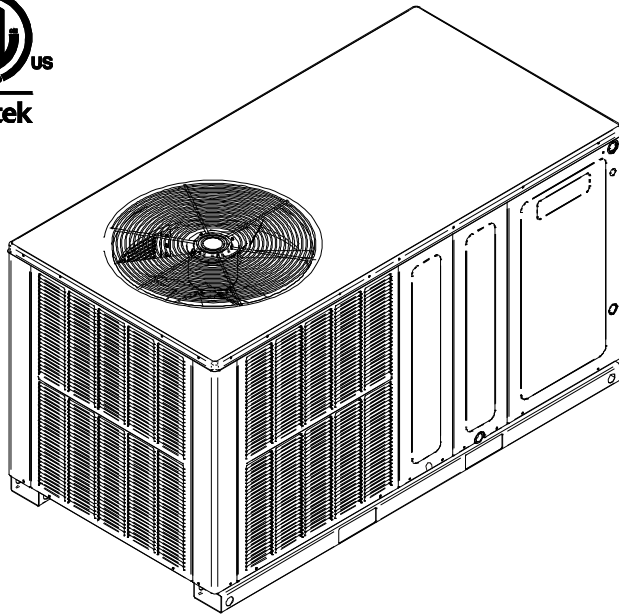

RECOGNIZE THIS SYMBOL AS A SAFETY PRECAUTION.

***NOTE: PLEASE CONTACT YOUR DISTRIBUTOR OR OUR WEBSITE FOR THE APPLICABLE SPECIFICATION SHEETS REFERRED TO IN THIS MANUAL.**

These installation instructions cover the outdoor installation of self contained package air conditioner and heating units. See the Specification Sheets applicable to your model for information regarding accessories.



WARNING

ONLY PERSONNEL THAT HAVE BEEN TRAINED TO INSTALL, ADJUST, SERVICE OR REPAIR (HEREINAFTER, “SERVICE”) THE EQUIPMENT SPECIFIED IN THIS MANUAL SHOULD SERVICE THE EQUIPMENT. THE MANUFACTURER WILL NOT BE RESPONSIBLE FOR ANY INJURY OR PROPERTY DAMAGE ARISING FROM IMPROPER SERVICE OR SERVICE PROCEDURES. IF YOU SERVICE THIS UNIT, YOU ASSUME RESPONSIBILITY FOR ANY INJURY OR PROPERTY DAMAGE WHICH MAY RESULT. IN ADDITION, IN JURISDICTIONS THAT REQUIRE ONE OR MORE LICENSES TO SERVICE THE EQUIPMENT SPECIFIED IN THIS MANUAL, ONLY LICENSED PERSONNEL SHOULD SERVICE THE EQUIPMENT. IMPROPER INSTALLATION, ADJUSTMENT, SERVICING OR REPAIR OF THE EQUIPMENT SPECIFIED IN THIS MANUAL, OR ATTEMPTING TO INSTALL, ADJUST, SERVICE OR REPAIR THE EQUIPMENT SPECIFIED IN THIS MANUAL WITHOUT PROPER TRAINING MAY RESULT IN PRODUCT DAMAGE, PROPERTY DAMAGE, PERSONAL INJURY OR DEATH.

TABLE OF CONTENTS

TO THE INSTALLER	2
SHIPPING INSPECTION	2
CHECKING PRODUCT RECEIVED	2
MESSAGE TO THE HOMEOWNER	2
REPLACEMENT PARTS	2
ORDERING PARTS	2
IMPORTANT SAFETY INSTRUCTIONS	2
RECOGNIZE SAFETY SYMBOLS, WORDS, AND LABELS ..	2
CODES AND REGULATIONS	3
GENERAL	3
EPA REGULATIONS	3
NATIONAL CODES	3
MAJOR COMPONENTS	4
GENERAL	4
INSTALLATION	4
PRE-INSTALLATION CHECKPOINTS	4
CLEARANCE	4
LOCATION	4
OUTSIDE SLAB INSTALLATION (FIGURE 1)	4
ROOFTOP INSTALLATION (FIGURE 2)	4
RIGGING	5
RIGGING DETAILS	5
DUCTING	5
CONNECTING THE RETURN AND SUPPLY	
FLEXIBLE DUCT IN MANUFACTURED OR	
MODULAR HOUSING APPLICATION	6
PLENUM APPLICATION	6
FILTERS	6
PIPING	6
CONDENSATE DRAIN	6

All information contained herein is subject to change without notice.

19001 Kermier Rd. Waller, TX 77484
 www.goodmanmfg.com • www.amana-hac.com
 © 2021 Goodman Manufacturing Company, L.P.



ELECTRICAL WIRING	7
LINE VOLTAGE WIRING	7
LOW VOLTAGE WIRING	8
INTERNAL WIRING:	8
OPERATION	8
START-UP PROCEDURE AND CHECKLIST	8
HEAT PUMP START-UP PROCEDURE	8
FINAL SYSTEM CHECKS	9
COMPONENTS	9
CONTACTOR	9
CRANKCASE HEATER	9
CONDENSER MOTOR	9
COMPRESSOR	9
CONTACTOR RELAY	9
DEFROST CONTROL	9
OUTDOOR THERMOSTAT	9
REVERSING VALVE COIL	9
INDOOR BLOWER MOTOR	9
BLOWER INTERLOCK RELAY	9
EXPLANATION AND GUIDANCE (HEAT PUMP)	10
HEAT PUMP REFRIGERANT CIRCUIT - FIGURE 8 .	10
DEFROST CONTROL	10
SUGGESTED FIELD TESTING/TROUBLESHOOTING .	11
TESTING THERMOSTAT CONTROL	11
AIR FLOW MEASUREMENT AND ADJUSTMENT	11
TOTAL EXTERNAL STATIC PRESSURE	11
ADJUSTING SPEED TAP FOR	
INDOOR BLOWER MOTOR	12
ECM MOTOR	12
REFRIGERANT CHARGE CHECK (UNITS WITH	
FIXED ORIFICE DEVICES)	12
UNITS WITH TXV DEVICE (*PCH360)	12
SUPERHEAT	12
CHECKING SUPERHEAT	12
SUBCOOLING	13
CHECKING SUBCOOLING	13
ELECTRIC HEAT INSTALLATION & ADJUSTMENT	14
HEATER KIT	14
MAINTENANCE	15
SERVICE	15
INADEQUATE AIR VOLUME THROUGH INDOOR COIL ...	15
OUTSIDE AIR INTO RETURN DUCT	15
UNDERCHARGE	15
POOR "TERMINATING" SENSOR CONTACT	15
MALFUNCTIONING REVERSING VALVE	15
BLOWER PERFORMANCE *P*H 13.4 SEER2	16
TROUBLESHOOTING CHART	18
UNIT DIMENSIONS	19
START-UP CHECKLIST	22

To The Installer

Carefully read all instructions for the installation prior to installing unit. Make sure each step or procedure is understood and any special considerations are taken into account before starting installation. Assemble all tools, hardware and supplies needed to complete the installation. Some items may need to be purchased locally. After deciding where to install unit, closely look the location over - both the inside and outside of home. Note any

potential obstacles or problems that might be encountered as noted in this manual. Choose a more suitable location if necessary.

IMPORTANT NOTE: IF A CRANKCASE HEATER IS USED, THE UNIT SHOULD BE ENERGIZED 24 HOURS PRIOR TO COMPRESSOR START UP TO ENSURE CRANKCASE HEATER HAS SUFFICIENTLY WARMED THE COMPRESSOR. COMPRESSOR DAMAGE MAY OCCUR IF THIS STEP IS NOT FOLLOWED.

Before using this manual, check the serial plate for proper model identification.

The installation and servicing of this equipment must be performed by qualified, experienced technicians only.

SHIPPING INSPECTION

CHECKING PRODUCT RECEIVED

Upon receiving the unit, inspect it for damage from shipment. Claims for damage, either shipping or concealed, should be filed immediately with the shipping company. Check the unit model number, specifications, electrical characteristics and accessories to determine if they are correct. In the event an incorrect unit is shipped, it must be returned to the supplier and must NOT be installed. The manufacturer assumes no responsibility for installation of incorrectly shipped units.

MESSAGE TO THE HOMEOWNER

These instructions are addressed primarily to the installer; however, useful maintenance information is included and should be kept, after installation, for future reference.

REPLACEMENT PARTS

ORDERING PARTS

When reporting shortages or damages, or ordering repair parts, give the complete unit model and serial numbers as stamped on the unit's nameplate. Replacement parts for this appliance are available through your contractor or local distributor. For the location of your nearest distributor, consult the white business pages, the yellow page section of the local telephone book or contact:

HOMEOWNER SUPPORT
 GOODMAN MANUFACTURING COMPANY, L.P.
 19001 KERMIER ROAD
 WALLER, TEXAS 77484
 855-770-5678

IMPORTANT SAFETY INSTRUCTIONS

Recognize Safety Symbols, Words, and Labels

The following symbols and labels are used throughout this manual to indicate immediate or potential hazards. It is the owner's responsibility to read and comply with all safety

information and instructions accompanying these symbols. Failure to heed safety information increases the risk of serious personal injury or death, property damage and/or product damage.

CODES AND REGULATIONS

GENERAL

The *PCH & *PHH series air conditioners and heat pumps are designed for OUTDOOR USE ONLY. This series is available in cooling Capacities of 2, 2 ½, 3, 3 ½, 4 and 5 nominal tons of cooling. Optional field installed heat kits are available in 5,8,10,15 and 20 KW. The units can be easily installed in manufactured or modular homes with existing high-static duct work. The units can also be easily converted to accommodate a plenum for normal or low-static applications. The *PCH & *PHH series are self contained packaged units so the only connections needed for installation are the supply and return ducts, the line and low voltage wiring and drain connection. Rated performance is achieved after 20 hours of operation. Rated performance is delivered at the specified airflow. See outdoor unit specification sheet for split system models or product specification sheet for packaged and light commercial models. Specification sheets can be found at www.goodmanmfg.com for Goodman® brand products or www.amana-hac.com for Amana® brand products. Within either website, please select the residential or commercial products menu and then select the submenu for the type of product to be installed, such as air conditioners or heat pumps, to access a list of product pages that each contain links to that model's specification sheet.

The information on the rating plate is in compliance with the FTC & DOE rating for single phase units. The three phase units in this series are not covered under the DOE certified program. The efficiency ratings of these units are a product of thermal efficiency determined under continuous operating conditions independent of any installed system.

EPA REGULATIONS

IMPORTANT: THE UNITED STATES ENVIRONMENTAL PROTECTION AGENCY (EPA) HAS ISSUED VARIOUS REGULATIONS REGARDING THE INTRODUCTION AND DISPOSAL OF REFRIGERANTS IN THIS UNIT. FAILURE TO FOLLOW THESE REGULATIONS MAY HARM THE ENVIRONMENT AND CAN LEAD TO THE IMPOSITION OF SUBSTANTIAL FINES. BECAUSE REGULATIONS MAY VARY DUE TO PASSAGE OF NEW LAWS, WE SUGGEST A CERTIFIED TECHNICIAN PERFORM ANY WORK DONE ON THIS UNIT. SHOULD YOU HAVE ANY QUESTIONS PLEASE CONTACT THE LOCAL OFFICE OF THE EPA.

NATIONAL CODES

This product is designed and manufactured to permit installation in accordance with National Codes. It is the installer's responsibility to install the product in accordance with National Codes and/or prevailing local codes and regulations.



WARNING

DO NOT CONNECT TO OR USE ANY DEVICE THAT IS NOT DESIGN CERTIFIED BY THE MANUFACTURER FOR USE WITH THIS UNIT. SERIOUS PROPERTY DAMAGE, PERSONAL INJURY, REDUCED UNIT PERFORMANCE AND/OR HAZARDOUS CONDITIONS MAY RESULT FROM THE USE OF SUCH NON-APPROVED DEVICES.



WARNING

**HIGH VOLTAGE!
DISCONNECT ALL POWER BEFORE SERVICING OR INSTALLING THIS UNIT. MULTIPLE POWER SOURCES MAY BE PRESENT. FAILURE TO DO SO MAY CAUSE PROPERTY DAMAGE, PERSONAL INJURY OR DEATH.**



WARNING

CONNECTING UNIT DUCT WORK TO UNAUTHORIZED HEAT PRODUCING DEVICES SUCH AS A FIREPLACE INSERT, STOVE, ETC. MAY RESULT IN PROPERTY DAMAGE, FIRE, CARBON MONOXIDE POISONING, EXPLOSION, PERSONAL INJURY OR DEATH.



WARNING

THIS PRODUCT CONTAINS OR PRODUCES A CHEMICAL OR CHEMICALS WHICH MAY CAUSE SERIOUS ILLNESS OR DEATH AND WHICH ARE KNOWN TO THE STATE OF CALIFORNIA TO CAUSE CANCER, BIRTH DEFECTS OR OTHER REPRODUCTIVE HARM.



WARNING

TO AVOID PROPERTY DAMAGE, PERSONAL INJURY OR DEATH, DO NOT USE THIS UNIT IF ANY PART HAS BEEN UNDER WATER. IMMEDIATELY CALL A QUALIFIED SERVICE TECHNICIAN TO INSPECT THE FURNACE AND TO REPLACE ANY PART OF THE CONTROL SYSTEM AND ANY GAS CONTROL HAVING BEEN UNDER WATER.



WARNING

THIS UNIT MUST NOT BE USED AS A "CONSTRUCTION HEATER" DURING THE FINISHING PHASES OF CONSTRUCTION ON A NEW STRUCTURE. THIS TYPE OF USE MAY RESULT IN PREMATURE FAILURE OF THE UNIT DUE TO EXTREMELY LOW RETURN AIR TEMPERATURE AND EXPOSURE TO CORROSIVE OR VERY DIRTY ATMOSPHERES.



WARNING

TO PREVENT THE RISK OF PROPERTY DAMAGE, PERSONAL INJURY, OR DEATH, DO NOT STORE COMBUSTIBLE MATERIALS OR USE GASOLINE OR OTHER FLAMMABLE LIQUIDS OR VAPORS IN THE VICINITY OF THIS APPLIANCE.

MAJOR COMPONENTS

GENERAL

The unit includes a hermetically sealed refrigerating system (consisting of a compressor, condenser coil, evaporator coil with flowrator), an indoor blower, a condenser fan and all necessary internal electrical wiring. The heat pump also includes a reversing valve, solenoid, defrost thermostat and control and loss of charge protection. The system is factory-evacuated, charged and performance tested. Refrigerant amount and type are indicated on rating plate.

INSTALLATION

PRE-INSTALLATION CHECKPOINTS

Before attempting any installation, the following points should be considered:

- Structural strength of supporting members
- Clearances and provision for servicing
- Power supply and wiring
- Air duct connections
- Drain facilities and connections
- Location may be on any four sides of a home, manufactured or modular, to minimize noise

CLEARANCE

The unit is designed to be located outside the building with unobstructed condenser air inlet and discharge. Additionally, the unit must be situated to permit access for service and installation. Condenser air enters from three sides. Air discharges upward from the top of the unit. Refrigerant gauge connections are made on the right side of the unit as you face the compressor compartment. Electrical connections can be made either on the right or left sides of the unit. The best and most common application is for the unit to be located 12" from wall (4" minimum) with the connection side facing the wall. This "close to the wall" application minimizes exposed wiring.

Close to the wall application assures free, unobstructed air to the other two sides. In more confined application spaces, such as corners provide a minimum 12" clearance on all air inlet sides. Allow 36" minimum for service access to the compressor compartment and controls. The top of the unit should be completely unobstructed. If units are to be located under an overhang, there should be a minimum of 48" clearance and provisions made to deflect the warm discharge air out from the overhang.

LOCATION

Consider the effect of outdoor fan noise on conditioned space and any adjacent occupied space. It is recommended that the unit be placed so that condenser air discharge does not blow toward windows less than 25 feet away.

The unit should be set on a solid, level foundation - preferably a concrete slab at least 4 inches thick. The slab should be above ground level and surrounded by a graveled area for good drainage. Any slab used as a unit's foundation should not adjoin the building as it is possible that sound and vibration may be transmitted to the structure. For rooftop installation, steel or treated wood beams should be used as unit support for load distribution.

Heat pumps require special location consideration in areas of heavy snow accumulation and/or areas with prolonged continuous subfreezing temperatures. Heat pump unit bases have holes under the outdoor coil to permit drainage of defrost water accumulation. The unit must be situated to permit free unobstructed drainage of the defrost water and ice. A minimum 2" clearance under the outdoor coil is required in the milder climates.

Heat Pump Elevation Chart	
Design Temperature	Suggested Minimum Elevation
+15° and above	2 - 1/2"
-5° to +14 °	8"
Below -5°	12"

OUTSIDE SLAB INSTALLATION (FIGURE 1)

1. The unit must be mounted on a solid, level foundation.
2. Select a location that will minimize the length of the supply and return ducts.
3. Select a location where external water drainage cannot collect around the unit.
4. Consideration should also be given to shade, appearance and noise.

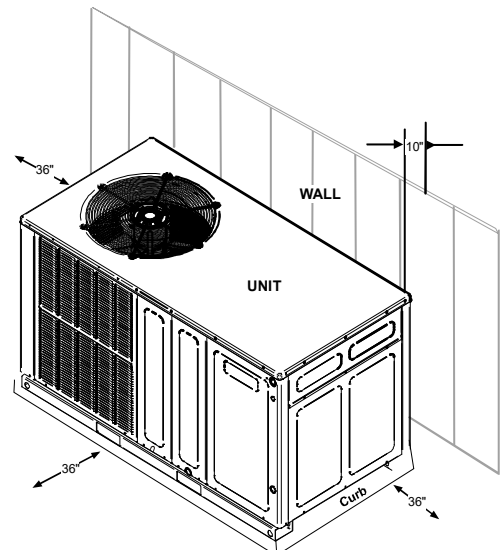

FIGURE 1

ROOFTOP INSTALLATION (FIGURE 2)

1. Before locating the unit on the roof, make sure that the strength of the roof and beams is adequate to support the weight involved. (See specification sheet for weight of units.) This is very important and the installer's responsibility.

2. Make proper consideration for the weather-tight integrity of the roof and proper drainage of condensate.
3. To ensure proper condensate drainage, unit must be installed in a level position.
4. Consideration should also be given to shade, appearance and noise.

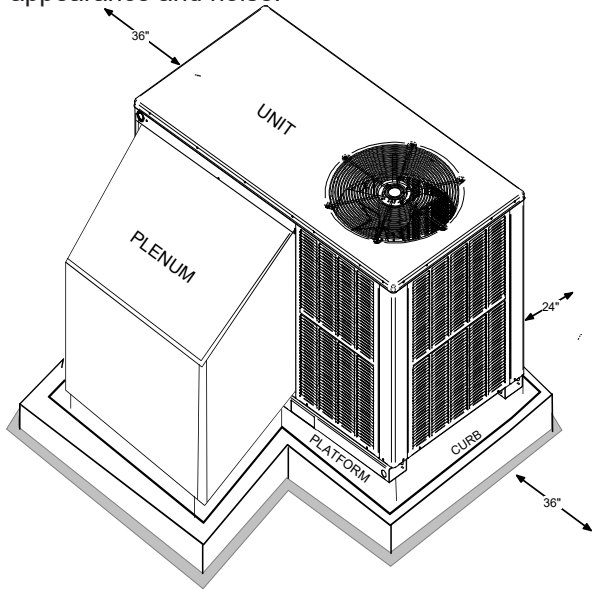

FIGURE 2

RIGGING

RIGGING DETAILS



WARNING

TO PREVENT PROPERTY DAMAGE, THE UNIT SHOULD REMAIN IN AN UPRIGHT POSITION DURING ALL RIGGING AND MOVING OPERATIONS. TO FACILITATE LIFTING AND MOVING WHEN A CRANE IS USED, PLACE THE UNIT IN AN ADEQUATE CABLE SLING.



CAUTION

IF UNITS ARE LIFTED TWO AT A TIME, THE FORK HOES ON THE CONDENSER END OF THE UNIT MUST NOT BE USED. MINIMUM FORK LENGTH IS 42" TO PREVENT DAMAGE TO THE UNIT; HOWEVER, 48" IS RECOMMENDED.

NOTE: PROVISIONS FOR FORKS HAVE BEEN INCLUDED IN THE UNIT BASE FRAME. NO OTHER FORK LOCATIONS ARE APPROVED.



WARNING

TO PREVENT POSSIBLE EQUIPMENT DAMAGE, PROPERTY DAMAGE, PERSONAL INJURY OR DEATH, THE FOLLOWING BULLET POINTS MUST BE OBSERVED WHEN INSTALLING THE UNIT.

Unit must be lifted by the four lifting holes located at the base frame corners.

- Lifting cables should be attached to the unit with shackles.

- The distance between the crane hook and the top of the unit must not be less than 60".
- Two spreader bars must span over the unit to prevent damage to the cabinet by the lift cables. Spreader bars must be of sufficient length so that cables do not come in contact with the unit during transport. Remove wood struts mounted beneath unit base frame before setting unit on roof curb. These struts are intended to protect unit base frame from fork lift damage. Removal is accomplished by extracting the sheet metal retainers and pulling the struts through the base of the unit. Refer to rigging label on the unit.

Refer to the Roof Curb Installation Instructions for proper curb installation. Curbing must be installed in compliance with the National Roofing Contractors Association Manual.

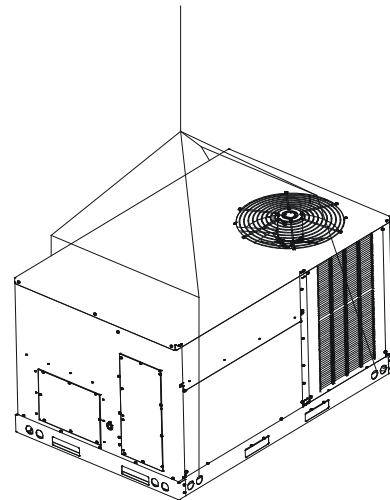

FIGURE 3



WARNING

DO NOT, UNDER ANY CIRCUMSTANCES, CONNECT RETURN DUCTWORK TO ANY OTHER HEAT PRODUCING DEVICES SUCH AS A FIREPLACE INSERT, STOVE, ETC. UNAUTHORIZED USE OF SUCH DEVICES MAY RESULT IN PROPERTY DAMAGE, FIRE, CARBON MONOXIDE POISONING, EXPLOSION, PERSONAL INJURY OR DEATH.

DUCTING

Ducting work should be fabricated by the installing contractor in accordance with local codes. Industry manuals may be used as a guide when sizing and designing the duct system- such as NESCA (National Environmental Systems Contractors Association, 1501 Wilson Blvd., Arlington, Virginia 22209).

The unit should be placed as close as possible to the space to be air-conditioned allowing clearance dimensions as indicated. Ducts should run as directly as possible to supply and return outlets. Use of non-flammable weatherproof flexible connectors on both supply and return connections at the unit to reduce noise transmission is recommended.

It is preferable to install the unit on the roof of the structure if the registers or diffusers are located in the wall or ceiling. A slab installation is recommended when the registers are low on the wall or in the floor.

CONNECTING THE RETURN AND SUPPLY FLEXIBLE DUCT IN MANUFACTURED OR MODULAR HOUSING APPLICATION

The return and supply fittings are to be attached at the unit to a suitable square to round duct converter. Your distributor has a factory designed square to round converter transition. The model #'s of these kits are as follows: Small Chassis 27.5" SQRPCH102, Large and Extra Large Chassis 32.5" and 36" SQRPCH103 (See Specification Sheets for Dimension details). The SQRPCH101 has 14" duct collar on supply and 16" duct collar (equivalent diameter, opening is oval) on the return. The SQRPCH102 and SQRPCH103 have 14" duct collar on supply and 18" duct collar (equivalent diameter, opening is oval) on the return. The collars are to be slipped into the openings, and the flanges bent around the converter. The square to round converter is attached to the flanges of the square duct openings. The flexible duct is then clamped on to the collars. Once the duct is affixed to the unit, **seal the collars and flanges with a proper waterproof sealant** (See Figure 4).

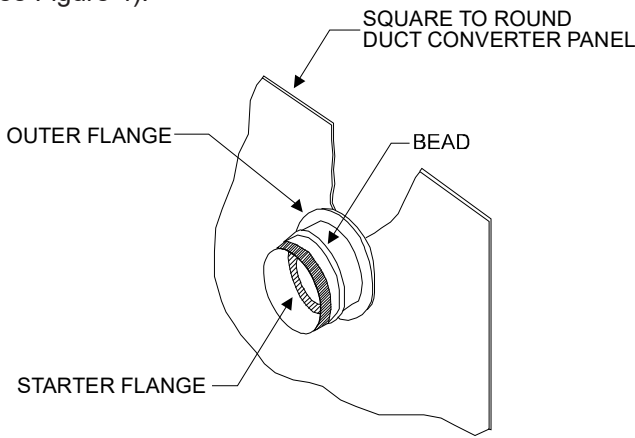

FIGURE 4

It is strongly encouraged to use appropriately sized ducts based upon the CFM for your application (unit's CFM). If duct sizing through industry manuals or air duct calculators require larger ducts than converter openings, run larger duct size up to unit converter openings and reduce with a reducer duct fitting or transition right at the unit.

PLENUM APPLICATION

A suitable plenum or square duct must be constructed. The duct cross-sectional area should be determined by industry duct sizing manuals or air duct calculators.

On ductwork exposed to outside air conditions of temperature and humidity, use an insulation with a good K factor, and a vapor barrier. Industry practices should be followed. Balancing dampers are recommended for each branch duct in the supply system. Ductwork should be properly supported from the unit.

NOTE: PROPER SEALING OF ALL DUCT WORK AND AIR HANDLING COMPARTMENTS IS EXTREMELY IMPORTANT TO OVERALL UNIT EFFICIENCY.

FILTERS

Filters are not provided with unit, and must be supplied and installed in the return duct system by the installer. A field installed filter grille is recommended for easy and convenient access to the filters for periodic inspection and cleaning. Filters must have adequate face area for the rated quantity of the unit. See air delivery tables (Figure 5) for recommended filter size.

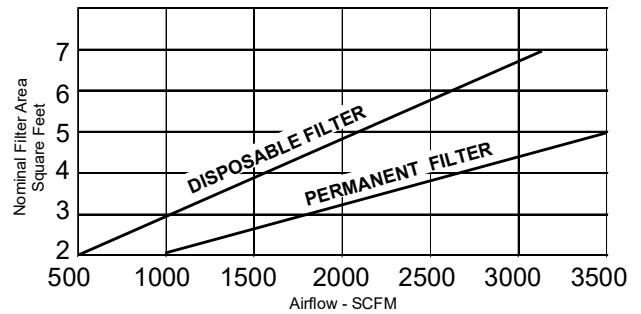

FIGURE 5

MINIMUM FILTER SIZE	
NOMINAL SIZE (INCHES)	NOMINAL AREA (SQ. FT.)
10x20	1.4
14x20	1.9
14x25	2.4
15x20	2.1
16x20	2.2
16x25	2.8
20x20	2.8
20x25	3.5
25x25	4.3

TABLE 1

PIPING

CONDENSATE DRAIN

The condensate drain connection of the evaporator is a half coupling of 3/4" N.P.T. A trap must be provided to have Proper condensate drainage.

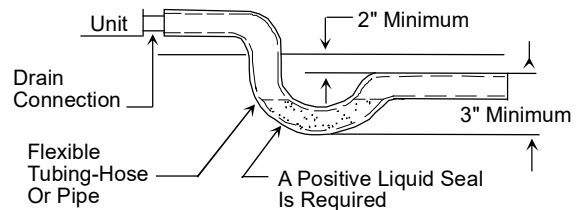

FIGURE 6

Install condensate drain trap as shown. Use 3/4" drain connection size or larger. Do not operate without trap. Unit must be level or slightly inclined toward drain.

ELECTRICAL WIRING



CAUTION

TO AVOID PROPERTY DAMAGE OR PERSONAL INJURY DUE TO FIRE, USE ONLY COPPER CONDUCTORS.

All wiring should be made in accordance with the National Electrical Code. The local Power Company should be consulted to determine the availability of sufficient power to operate the unit. The voltage, frequency, and phase at the power supply should be checked to make sure it corresponds to the unit's RATED VOLTAGE REQUIREMENT.

Install a branch circuit fused disconnect near the unit, in accordance with the N.E.C. or local codes. Wire sizes and overcurrent protection should be determined from the unit nameplate ampacity and in accordance with Table 2 (page 7) or the N.E.C. Under no circumstances should wiring be sized smaller than is recommended by either of these two sources.

Fuses smaller than that recommended on the wiring diagrams could result in unnecessary fuse failure or service calls. The use of protective devices of larger size than indicated could result in extensive damage to the equipment. The manufacturer bears no responsibility for damage caused to equipment as result of the use of larger than is recommended size protective devices.

All units have undergone a run test prior to packaging for shipment. This equipment has been started at minimum rated voltage and checked for satisfactory operation. Do not attempt to operate this unit if the voltage is not within the minimum and maximum voltages shown on nameplate.

The units are designed for operation on 60 hertz current and at voltages as shown on the rating plate. All internal wiring in the unit is complete. It is necessary to bring in the power supply to the contactor as shown on the unit wiring diagram which is supplied with each unit. The low voltage wiring must be connected between the unit control panel and the room thermostat.

All exterior wiring must be within approved weatherproof conduit. The unit must be **permanently grounded** in accordance with local codes, or in absence of local codes, with N.E.C ANSI/ NFPA NO. 70-1984 or latest edition by using ground lug in the control box.

DO NOT EXCEED THE MAXIMUM OVERCURRENT DEVICE SIZE SHOWN ON UNIT DATA PLATE.

Fuses or HACR type circuit breakers may be used where codes permit.

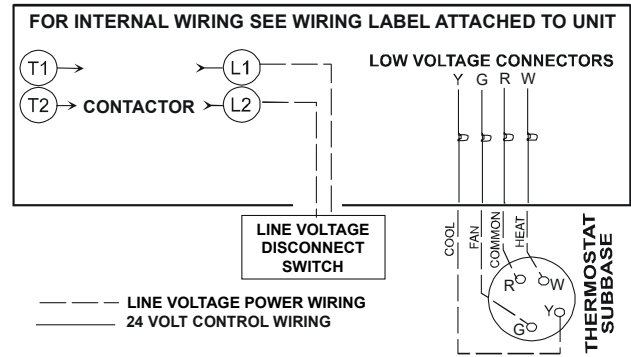

FIGURE 7

NOTE: UNITS ARE EQUIPPED WITH A SINGLE POLE CONTACTOR. CAUTION MUST BE EXERCISED WHEN SERVICING AS ONLY ONE LEG OF THE POWER SUPPLY IS BROKEN WITH THE CONTACTOR.

To wire the unit, make the following high and low voltage connections.



WARNING

HIGH VOLTAGE!
DISCONNECT ALL POWER BEFORE SERVICING OR INSTALLING THIS UNIT. MULTIPLE POWER SOURCES MAY BE PRESENT. FAILURE TO DO SO MAY CAUSE PROPERTY DAMAGE, PERSONAL INJURY OR DEATH.



LINE VOLTAGE WIRING: (SEE FIGURE 7)

Rated Voltage	Minimum Supply Voltage	Maximum Supply Voltage
208/230V	197	253

UNIT VOLTAGE

NOTE: THE UNIT TRANSFORMER IS FACTORY CONNECTED FOR 230V OPERATION. IF THE UNIT IS TO OPERATE ON 208V, RECONNECT THE TRANSFORMER PRIMARY LEAD AS SHOWN ON THE UNIT WIRING DIAGRAM.

Connect incoming power leads to terminals L1 & L2 on contactor in the electrical control section, using wire sizes specified in wiring table.

BRANCH CIRCUIT AMPACITY	15	20	25	30	35	40	45	50
SUPPLY WIRE LENGTH - FEET								
200	6	4	4	4	3	3	2	2
150	8	6	6	4	4	4	3	3
100	10	8	8	6	6	6	4	4
50	14	12	10	10	8	8	6	6

TABLE 2

LOW VOLTAGE WIRING: (SEE FIGURE 7)

- a. Air Conditioners - Connect 24V wires from the thermostat to the corresponding wires in the control box using No. 18AWG as follows:

LEAD	THERMOSTAT
Red	R (24V)
Green	G (Fan)
Yellow	Y (Cool)
White	W1 (Heat)*
Brown	W2 (Heat)*

TABLE 3

- b. Heat Pumps - Connect 24V wires from the thermostat to the corresponding wires in the control box using No. 18AWG as follows:

TERMINAL	THERMOSTAT
Red	R (24V)
Green	G (Fan)
Orange	O (Rev. Valve)
White	W1 (Heat, 2nd)*
Brown	W2 (Heat 3rd)*
Yellow	Y (Cool)
C (Blue)	C (Common)

*OPTIONAL FIELD INSTALLED HEAT CONNECTIONS
TABLE 4

INTERNAL WIRING:



A diagram detailing the internal wiring of this unit is located on the electrical box cover. If any of the original wire supplied with the appliance must be replaced, the wire gauge and insulation must be the same as the original wiring.

1. For branch circuit wiring (main power supply to unit disconnect), the minimum wire size for the length of the run can be determined from Table 2 using the circuit ampacity found on the unit rating plate. From the unit disconnect to unit, the smallest wire size allowable in Table 4 may be used for the ampacity, as the Disconnect must be in sight of the unit.
2. Wire size based on 60°C rated wire insulation and 30° C Ambient Temperature (86°F).
3. For more than 3 conductors in a raceway or cable, see the N.E.C. for derating the ampacity of each conductor.

OPERATION



START-UP PROCEDURE AND CHECKLIST

Begin with power turned off at all disconnects.

	WARNING
<p>HIGH VOLTAGE! DISCONNECT ALL POWER BEFORE SERVICING OR INSTALLING THIS UNIT. MULTIPLE POWER SOURCES MAY BE PRESENT. FAILURE TO DO SO MAY CAUSE PROPERTY DAMAGE, PERSONAL INJURY OR DEATH.</p>	
	

AIR CONDITIONER START-UP PROCEDURE

1. Turn thermostat system switch to “Cool,” and fan-switch to “Auto” and turn temperature setting as high as it will go.
2. Inspect all registers and set them to the normal open position.
3. Turn on the electrical supply at the disconnect.
4. Turn the fan switch to the “ON” position. The blower should operate after a 10 second delay.
5. Turn the fan switch to “Auto” position. The blower should stop after a 60 second delay.
6. Slowly lower the cooling temperature until the unit starts. The compressor, blower and fan should now be operating. Allow the unit to run 10 minutes, make sure cool air is being supplied by the unit.
7. Turn the temperature setting to the highest position, stopping the unit. The indoor blower will continue to run for 60 seconds.
8. Turn the thermostat system switch to “OFF” and disconnect all power when servicing the unit.

	WARNING
<p>HIGH VOLTAGE! DISCONNECT ALL POWER BEFORE SERVICING OR INSTALLING THIS UNIT. MULTIPLE POWER SOURCES MAY BE PRESENT. FAILURE TO DO SO MAY CAUSE PROPERTY DAMAGE, PERSONAL INJURY OR DEATH.</p>	
	

HEAT PUMP START-UP PROCEDURE

1. Check the cooling mode for the heat pump in the same manner as above. The reversing valve is energized when the thermostat is placed in the cooling position. A clicking sound should be noticeable from the reversing valve. By lowering the temperature setting to call for cooling, the contractor is energized. The compressor, blower and fan should then be running. After the cooling mode is checked out, turn the thermostat system switch to “OFF”.
2. Turn the thermostat system switch to “HEAT” and fan switch to “AUTO”.
3. Slowly raise the heating temperature setting. When the heating first stage makes contact, stop raising the temperature setting. The compressor, blower and fan should now be running with the reversing valve in the de-energized (heating) position. After giving the unit time to settle out, make sure the unit is supplying heated air.
4. If the outdoor ambient is above 80°F, the unit may trip on its high pressure cutout when in heating mode. The compressor should stop. The heating cycle must be thoroughly checked, so postpone the test to another day when conditions are more suitable but-DO NOT FAIL TO TEST.
5. If the outdoor ambient is low and the unit operates properly in the heating cycle, you may check the pressure cutout operation by blocking off the indoor

return air until the unit trips. If unit operates properly in the heating cycle, raise the temperature setting until the heating second stage makes contact. Supplemental resistance heat, if installed should now come on. Make sure it operates properly.

NOTE: IF OUTDOOR THERMOSTATS ARE INSTALLED THE OUTDOOR AMBIENT MUST BE BELOW THE SET POINT OF THESE THERMOSTATS FOR THE HEATERS TO OPERATE. IT MAY BE NECESSARY TO JUMPER THESE THERMOSTATS TO CHECK HEATER OPERATION IF OUTDOOR AMBIENT IS MILD.

6. For thermostats with emergency heat switch, return to step 11. The emergency heat switch is located at the bottom of the thermostat. Move the switch to emergency heat. The heat pump will stop, the blower will continue to run, all heaters will come on and the thermostat emergency heat light will come on.
7. If checking the unit in the wintertime, when the outdoor coil is cold enough to actuate the defrost control, observe at least one defrost cycle to make sure the unit defrosts completely.

FINAL SYSTEM CHECKS

Check to see if all supply and return air grilles are adjusted and the air distribution system is balanced for the best compromise between heating and cooling.

Check for air leaks in the ductwork.

See Sections on **Air Flow Measurement and Adjustment and Checking Charge.**

Make sure the unit is free of “rattles”, and the tubing in the unit is free from excessive vibration. Also make sure tubes or lines are not rubbing against each other or sheet metal surfaces or edges. If so, correct the trouble.

Set the thermostat at the appropriate setting for cooling and heating or automatic changeover for normal use.

Be sure the Owner is instructed on the unit operation, filter, servicing, correct thermostat operation, etc.

The foregoing “Start-up Procedure and Check List” is recommended to serve as an indication that the unit will operate normally.

COMPONENTS

1. **Contactors** - This control is activated (closed) by the room thermostat for both heating and cooling. The contactor has a 24V coil and supplies power to the compressor and outdoor fan motor.
2. **Crankcase Heater** - This item is “ON” whenever power is supplied to the unit and the crankcase heater thermostat is closed. Crankcase heater thermostat closes at 67° and opens at 85°. It warms the compressor crankcase thereby preventing liquid

migration and subsequent compressor damage. The insert type heater is self regulating. It is connected electrically to the contactor L1 and L2 terminals.

3. **Condenser Motor** - This item is activated by the contactor during heating and cooling, except during defrost and emergency heat operation.
4. **Compressor** - This item is activated by the contactor for heating and cooling, except during emergency heat. It is protected by an internal overload.
5. **Contactors Relay** - This control is activated by the thermostat (24V coil) and supplies power to the contactor.
6. **Defrost Control** - The Defrost control provides time/temperature initiation and termination of the defrost cycle. When a Defrost cycle is initiated, the defrost control shifts the reversing valve to “cooling” mode, stops the outdoor fan and brings on supplemental heat. Normally, a Defrost cycle will take only 2-3 minutes unless system is low on charge or outdoor conditions are severe (windy and cold). The defrost control also provides for a 3 minute off cycle compressor delay.
7. **Outdoor Thermostat** - These optional controls are used to prevent full electric heater operation at varying outdoor ambient (0°F to 45°F). They are normally open above their set points and closed below to permit staging of indoor supplement heater operation. If the outdoor ambient temperature is below 0°F (-18°C) with 50% or higher RH, an outdoor thermostat (OT) must be installed and set at (0°) on the dial. Failure to comply with this requirement may result in damage to the product which may not be covered by the manufacturer’s warranty.
8. **Reversing Valve Coil** - This coil is activated by the thermostat, in the cooling mode and during defrost. It positions the reversing valve pilot valve for cooling operation.
9. **Indoor Blower Motor** - Units with ECM Motors. The ECM model indoor blower motor is activated by the room thermostat by cooling/HEATING or fan ON position. The motor is energized by a 24 volt control signal (from thermostat Y, G or W) for ECM motors. ECM motors are constant torque motors with very low power consumption.

(See **Air Flow Measurement and Adjustment** for speed adjustment instructions).

10. **Blower Interlock Relay** - This relay is used to energize the blower during the electric heat operation. Some room thermostats do not energize the motor during electric heat. This relay insures blower operation when the room thermostat energizes heat. This relay has a 240 volt coil and an 8 amp contact relay. This relay is energized by the electric heat kit sequencer.

EXPLANATION AND GUIDANCE (HEAT PUMP)

The heat pump is a relatively simple device. It operates exactly as a Summer Air Conditioner unit when it is on the cooling cycle. Therefore, all the charts and data for service that apply to summer air conditioning apply to the heat pump when it is on the cooling cycle, and most apply on the heating cycle except that “condenser” becomes “evaporator”, “evaporator” becomes “condenser”, “cooling” becomes “heating”.

When the heat pump is on the heating cycle, it is necessary to redirect the refrigerant flow through the refrigerant circuit external to the compressor. This is accomplished with a reversing valve. Thus, the hot discharge vapor from the compressor is directed to the indoor coil (evaporator on the cooling cycle) where the heat is removed, and the vapor condenses to liquid. It then goes through the expansion device to the outdoor coil (condenser on the cooling cycle) where the liquid is evaporated, and the vapor goes to the compressor.

When the solenoid valve coil is operated either from heating to cooling or vice versa, the piston in the reversing valve to the low pressure (high pressure) reverse positions in the reversing valve.

Figure 8 shows a schematic of a heat pump on the cooling cycle and the heating cycle. In addition to a reversing valve, a heat pump is equipped with an expansion device and check valve for the indoor coil, and similar equipment for the outdoor coil. It is also provided with a defrost control system.

The expansion devices are flowrator distributors and perform the same function on the heating cycle as on the cooling cycle. The flowrator distributors also act as check valves to allow for the reverse of refrigerant flow.

When the heat pump is on the heating cycle, the outdoor coil is functioning as an evaporator. The temperature of the refrigerant in the outdoor coil must be below the temperature of the outdoor air in order to extract heat from the air. Thus, the greater the difference in the outdoor temperature and the outdoor coil temperature, the greater the heating capacity of the heat pump. This phenomenon is a characteristic of a heat pump. It is a good practice to provide supplementary heat for all heat pump installations in areas where the temperature drops below 45°F. It is also a good practice to provide sufficient supplementary heat to handle the entire heating requirement should there be a component failure of the heat pump, such as a compressor, or refrigerant leak, etc.

Since the temperature of the liquid refrigerant in the outdoor coil on the heating cycle is generally below freezing point, frost forms on the surfaces of the outdoor coil under certain weather conditions of temperature and

relative humidity. Therefore, it is necessary to reverse the flow of the refrigerant to provide hot gas in the outdoor coil to melt the frost accumulation. This is accomplished by reversing the heat pump to the cooling cycle. At the same time, the outdoor fan stops to hasten the temperature rise of the outdoor coil and lessen the time required for defrosting. The indoor blower continues to run and the supplementary heaters are energized.

SYSTEM OPERATION

Typical Heat Pump System in Cooling

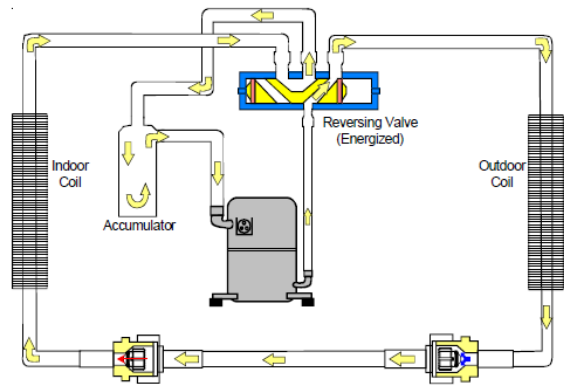

Typical Heat Pump System in Heating

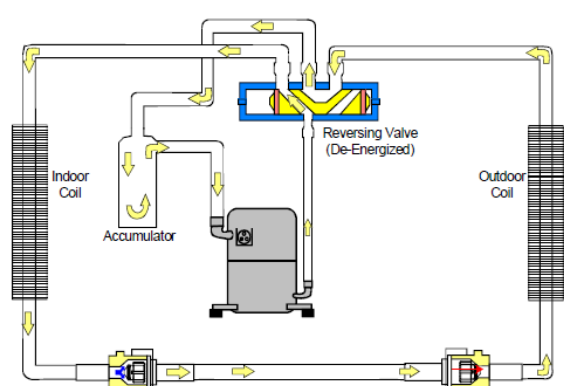

HEAT PUMP REFRIGERANT CIRCUIT
FIGURE 8

DEFROST CONTROL

During operation the power to the circuit board is controlled by a temperature sensor, which is clamped to a feeder tube entering the outdoor coil. Defrost timing periods of 30, 60 and 90 minutes may be selected by setting the circuit board jumper to 30, 60 and 90 respectively. Accumulation of time for the timing period selected starts when the sensor closes (approximately $30 \pm 5^\circ\text{F}$), and when the wall thermostat calls for heat. At the end of the timing period, the unit's defrost cycle will be initiated provided the sensor remains closed. When the sensor opens (approximately 60°F), the defrost cycle is terminated and the timing period is reset. If the defrost cycle is not terminated due to the sensor temperature, a twelve minute override interrupts the unit's defrost period.

SUGGESTED FIELD TESTING /TROUBLESHOOTING

TESTING DEFROST CONTROL

NOTE: PCBDM133 DEFROST CONTROLS HAVE A THREE (3) MINUTE COMPRESSOR OFF CYCLE DELAY.

NOTE: THE PCBDM133 DEFROST CONTROLS ARE SHIPPED FROM THE FACTORY WITH THE COMPRESSOR DELAY OPTION SELECTED. THIS WILL DE-ENERGIZE THE COMPRESSOR CONTACTOR FOR 30 SECONDS ON DEFROST INITIATION AND DEFROST TERMINATION. IF THE JUMPER IS SET TO NORMAL, THE COMPRESSOR WILL CONTINUE TO RUN DURING DEFROST INITIATION AND DEFROST TERMINATION. THE CONTROL WILL ALSO IGNORE THE LOW-PRESSURE SWITCH CONNECTED TO R-PS1 AND PS2 FOR 5 MINUTES UPON DEFROST INITIATION AND 5 MINUTES AFTER DEFROST TERMINATION.

To check the defrost control for proper sequencing, proceed as follows: With power ON; unit not running.

1. Jumper defrost thermostat by placing a jumper wire across the terminals "DFT" and "R"/" R-DFT" at defrost control board.
2. Remove jumper from timer pins and jump across test pins on defrost control board.
NOTE: Do not use screwdriver or field supplied jumper to test the control.
3. Set thermostat to call for heating. System should go into defrost within 21 seconds.
4. Immediately remove jumper from test pins.
5. Using VOM check for voltage across terminals "C & O". Meter should read 24 volts.
6. Using VOM check for voltage across fan terminals DF1 and DF2 on the board. Should read line voltage (208-230 VAC) indicating the relay is open in the defrost mode.
7. Using VOM check for voltage across "W"/"W2" & "C" terminals on the board. Should read 24 volts.
8. If not as above, replace control board.
9. Set thermostat to off position and disconnect power. Remove jumper from defrost thermostat and replace timer jumper to the desired defrost time.

NOTE: REMOVE JUMPER ACROSS DEFROST THERMOSTAT BEFORE RETURNING SYSTEM TO SERVICE.

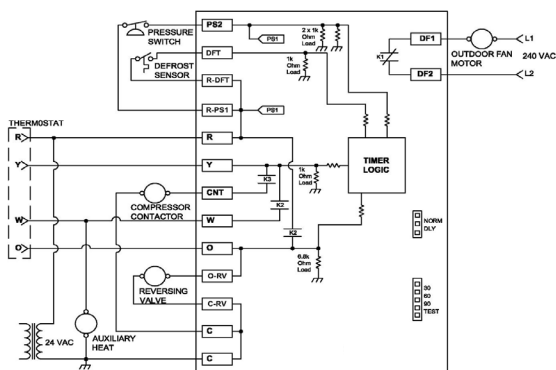

PCBDM133 DEFROST CONTROL
FIGURE 9

TESTING DEFROST THERMOSTAT

1. Install a thermocouple type temperature test lead on the tube adjacent to the defrost control. Insulate the lead point of contact.
2. Check the temperature at which the control closes its contacts by lowering the temperature of the control. It should close at approximately 30°F.
3. Check the temperature at which the control opens its contacts by raising the temperature of the control. It should open at approximately 60°F.
4. If not as above, replace control.

AIR FLOW MEASUREMENT AND ADJUSTMENT

After reviewing section on DUCTING, proceed with airflow measurements and adjustments. Unit's blower curves (in Specification Sheets) are based on external static pressure (ESP, in. of W.C.). The duct openings on the unit are considered internal static pressure, so as long as ESP is maintained, the unit will deliver the proper air up to the maximum static pressure listed for the CFM required by the application (i.e. home, building, etc.).

In general 400 CFM per ton of cooling capacity is a rule of thumb. Some applications depending on the sensible and latent capacity requirements may need only 350 CFM or up to 425 CFM per ton. Check condition space load requirements (from load calculations) and equipment expanded ratings data to match CFM and capacity. After unit is set and ducted, verify ESP with a 1" inclined manometer with pitot tubes or a Magnahelic gauge and confirm CFM to blower curves in the specification sheets. All units have multiple speed blower motors. If factory selected speed is not utilized, the speed tap can be changed. Never run CFM below 350 CFM per ton, evaporator freezing or poor unit performance is possible.

TOTAL EXTERNAL STATIC PRESSURE

1. Using a digital manometer measure the static pressure of the return duct at the inlet of the unit (Negative Pressure).

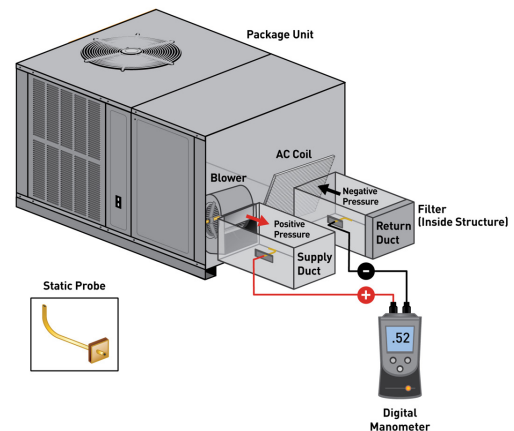

TOTAL EXTERNAL STATIC
FIGURE 10

2. Measure the static pressure of the supply duct (Positive Pressure).
3. Add the two readings together.

NOTE: BOTH READINGS MAY BE TAKEN SIMULTANEOUSLY AND READ DIRECTLY ON THE MANOMETER IF SO DESIRED.

4. Consult proper table for quantity of air.

If the external static pressure exceeds the minimum or maximum allowable statics, check for closed dampers, dirty filter, undersized or poorly laid out ductwork.

ADJUSTING SPEED TAP FOR INDOOR BLOWER MOTOR

ECM Motor

The blower motor speed for the ECM motor is controlled by three 24V low voltage leads: green, yellow, and white. The green lead sets the speed for fan-only mode. The yellow lead sets the speed for cooling and heat pump heating mode (if applicable). The white lead sets the speed for electric heat mode (emergency heat and second stage heat, if applicable).

The leads are factory connected as follows: Green to T1, Yellow to T2, and White to T3. T1 is the low speed setting and is dedicated to fan-only mode. T2 is medium speed cooling and T3 is medium speed heating. T4 is high speed cooling and T5 is high speed heating. To adjust the blower speed, move the yellow and/or white wires to T4 and T5.

NOTE: IF MORE THAN ONE LEAD IS ENERGIZED AT THE SAME TIME, THE MOTOR WILL USE THE HIGHER SPEED SETTING.

NOTE: *PCH3 AND *PHH3 UNITS ARE RATED FOR A MAXIMUM E.S.P. OF 0.8 EXCEPT WHEN USING A 20KW ELECTRIC HEATER. (THE MAXIMUM STATIC FOR 20 kW ELECTRIC HEAT IS 0.5 E.S.P.) WHEN THESE UNITS ARE INSTALLED IN THE 0.5 - 0.8 E.S.P. RANGE, THE WHITE LEAD (ELECTRIC HEAT) MUST BE MOVED TO T5 FOR PROPER OPERATION OF THE ELECTRIC HEATERS.

See CFM vs ESP tables in this manual.

Refrigerant Charge Check (Units with Fixed Orifice Devices)

After completing airflow measurements and adjustments the unit's refrigerant charge must be checked. All package units with fixed orifice devices are charged using the superheat method at the compressor suction line. After superheat is adjusted it is recommended to check unit sub-cooling at the condenser coil liquid line out. For charge adjustments, see superheat and subcooling charts shown for each model.

(UNITS WITH TXV) (*PCH360)

All package units with TXV devices are charged using the subcooling method at the liquid line. After subcooling is adjusted it is recommended to check unit superheat at the evaporator coil suction line. For charge adjustments, see superheat and subcooling charts shown for each model.

Systems with TXV application should have a subcooling and superheat within the range listed on the chart.

The TXV should NOT be adjusted at light load conditions 55° to 60°F, under such conditions only the subcooling can be evaluated. This is because suction pressure is dependent on indoor air flow, and wet bulb temperature.

NOTE: Do NOT ADJUST CHARGE BASED ON SUCTION PRESSURE UNLESS THERE IS A GROSS UNDERCHARGE.

SUPERHEAT CAN BE DETERMINED AS FOLLOWS:

SUPERHEAT

CHECKING SUPERHEAT

Refrigerant gas is considered superheated whenever its temperature is higher than the saturation temperature corresponding to its pressure. The degree of superheat equals the degrees of temperature increase above the saturation temperature at existing pressure. See Temperature - Pressure Chart.

Procedure:

1. Run system at least 10 minutes to allow pressure to stabilize.
2. Install a low side pressure gauge on the suction line access fitting.
3. Temporarily install thermometer on suction (large) line near compressor with adequate contact and insulate for best possible reading.
4. Record the gauge pressure corresponding temperature and the temperature of the suction line.
5. Refer to the superheat table for proper system superheat. Add charge to lower superheat recover charge to raise superheat.

Superheat Formula = Suct. Line Temp. - Sat. Suct. Temp.

Ambient Condenser Inlet Temp (°F Drybulb)	Return Air Temp. (°F Wetbulb)				
	65	70	75	80	85
100	-	-	-	10	10
95			10	10	10
90	-	-	12	15	18
85	-	10	13	17	20
80	-	10	15	21	26
75	10	13	17	25	29
70	10	17	20	28	32
65	13	19	26	32	35
60	17	25	30	33	37

To obtain the amount of subcooling, subtract 109°F from 120°F. The difference is 11° subcooling. See the specification sheet or technical information manual for the design subcooling range for your unit.

SUBCOOLING FORMULA = SAT. LIQUID TEMP. - LIQUID LINE TEMP.

EXAMPLE:

- a. Suction Pressure = 143
- b. Corresponding Temp. °F. = 50
- c. Thermometer on Suction Line = 59°F

To obtain the degrees temperature of superheat, subtract 50.0 from 59.0°F. The difference is 9° Superheat. The 9° Superheat would fall in the ± range of allowable superheat.

SUBCOOLING

CHECKING SUBCOOLING

Refrigerant liquid is considered subcooled when its temperature is lower than the saturation temperature corresponding to its pressure. The degree of subcooling equals the degrees of temperature decrease below the saturation temperature at the existing pressure.

Procedure:

1. Attach an accurate thermometer or preferably a thermocouple type temperature tester to the liquid line close to the pressure switch.
2. Install a high side pressure gauge on the liquid access fitting.
3. Record the gauge pressure and the temperature of the line.
4. The difference between the thermometer reading and pressure to temperature conversion is the amount of subcooling.

EXAMPLE:

- a. Liquid Line Pressure = 417
- b. Corresponding Temp. °F. = 120°
- c. Thermometer on Liquid line = 109°F.

SATURATED SUCTION PRESSURE TEMPERATURE CHART		SATURATED LIQUID PRESSURE TEMPERATURE CHART	
SUCTION PRESSURE	SATURATED SUCTION TEMPERATURE °F	LIQUID PRESSURE	SATURATED LIQUID TEMPERATURE °F
PSIG	R-410A	PSIG	R-410A
50	1	200	70
52	3	210	73
54	4	220	76
56	6	225	78
58	7	235	80
60	8	245	83
62	10	255	85
64	11	265	88
66	13	275	90
68	14	285	92
70	15	295	95
72	16	305	97
74	17	325	101
76	19	355	108
78	20	375	112
80	21	405	118
85	24	415	119
90	26	425	121
95	29	435	123
100	31	445	125
110	36	475	130
120	41	500	134
130	45	525	138
140	49	550	142
150	53	575	145
160	56	600	149
170	60	625	152

SUCTION PRESSURE TEMPERATURE (R-410A)

LIQUID PRESSURE TEMPERATURE (R-410A)

*PCH3		
Design superheat @ 95°F outdoor ambient temperature		
Model	Superheat ± 2°F	Supercooling ± 2°F
GPCH32441	17°	-
APCH32441	15°	-
*PCH33041	3°	-
*PCH33641	9°	-
*PCH34241	17°	-
*PCH34841	5°	-
*PCH36041	9°	13°

*PHH3		
Design Superheat @ 95°F outdoor ambient temperature		
Models	Superheat ± 2°F	Subcooling ± 2°F
*PHH32441	5°	-
*PHH33041	5°	-
*PHH33641	6°	-
*PHH34241	7°	-
*PHH34841	12°	-
*PHH36041	8°	-

ELECTRIC HEAT INSTALLATION & ADJUSTMENT

HEATER KIT

NOTE: A SEPARATE POWER SUPPLY IS REQUIRED FOR THE HKR/HKP HEATER KITS.

Refer to the Heat Kit Electrical Data (Blower Only, Heat Mode) specification table below for heater kit match up and heater kit electrical data information. See specific kit installation manual for installation instructions.

This series of electric cooling and heat pump package equipment is designed to accept a field installed electric heat kit. The unit is equipped to easily install the HKR/HKP Series Electric Heat Kit. Full Installation Instructions are included in this kit. Please use this document for guidance in field equipping the package unit with electric heat. Choose the heat kit that fits the application for the specific installation. Permanently mark the unit's nameplate with the model being installed. High and low voltage connections are detailed in the heat kit instructions. Indoor Blower motor speed tap selection may need to be modified to accommodate normal continuous operation to prevent a nuisance trip. *See following table.*

*PHH3

Model and Heat Kit Usage	Circuit #1		Circuit #2		Single-Point Kit		Actual kW / BTU@ 240V
	MCA ¹	MOD ²	MCA ¹	MOD ²	MCA ¹	MOP ²	
*PHH32441**	1.9	---	---	---	---	---	---
HKR-05*, HKR-05C*	21 / 25	25 / 25	---	---	46	50	4.75 / 16,200
HKR-08*, HKR-08C*	32 / 36	35 / 40	---	---	57	60	7 / 23,800
HKR-10*, HKR-10C*	43 / 49	45 / 50	---	---	70	80	9.5 / 32,400
*PHH33041**	2.3	---	---	---	---	---	---
HKR-05*, HKR-05C*	21 / 25	25 / 25	---	---	47	50	4.75 / 16,200
HKR-08*, HKR-08C*	32 / 36	35 / 40	---	---	59	60	7 / 23,800
HKR-10*, HKR-10C*	43 / 49	45 / 50	---	---	72	80	9.5 / 32,400
HKP-15C*	43 / 49	45 / 50	21 / 25	25 / 25	97	100	14.25 / 48,600
*PHH33641**	2.3	---	---	---	---	---	---
HKR-05*, HKR-05C*	21 / 25	25 / 25	---	---	51	60	4.75 / 16,200
HKR-08*, HKR-08C*	32 / 36	35 / 40	---	---	62.7	70	7 / 23,800
HKR-10*, HKR-10C*	43 / 49	45 / 50	---	---	75.8	80	9.5 / 32,400
HKP-15C*	43 / 49	45 / 50	21 / 25	25 / 25	100.5	110	14.25 / 48,600
*PHH34241**	3.6	---	---	---	---	---	---
HKP-05C*	21 / 25	25 / 25	---	---	52	60	4.75 / 16,200
HKR-08C*	32 / 36	35 / 40	---	---	64	70	7 / 23,800
HKP-10C*	43 / 49	45 / 50	---	---	77	80	9.5 / 32,400
HKP-15C*	43 / 49	45 / 50	21 / 25	25 / 25	102	110	14.25 / 48,600
HKP-20C	43 / 49	45 / 50	43 / 49	45 / 50	127	150	19.0 / 64,800
*PHH34841**	3.6	---	---	---	---	---	---
HKP-05C*	21 / 25	25 / 25	---	---	56	70	4.75 / 16,200
HKR-08C*	32 / 36	35 / 40	---	---	68	80	7 / 23,800
HKP-10C*	43 / 49	45 / 50	---	---	81	90	9.5 / 32,400
HKP-15C*	43 / 49	45 / 50	21 / 25	25 / 25	106	110	14.25 / 48,600
HKP-20C	43 / 49	45 / 50	43 / 49	45 / 50	131	150	19.0 / 64,800
*PHH36041**	7.5	---	---	---	---	---	---
HKR-05C*	21 / 25	25 / 25	---	---	65	80	4.75 / 16,200
HKR-08C*	32 / 36	35 / 40	---	---	76	90	7 / 23,800
HKP-10C*	43 / 49	45 / 50	---	---	89	100	9.5 / 32,400
HKP-15C*	43 / 49	45 / 50	21 / 25	25 / 25	114	125	14.25 / 48,600
HKP-20C	43 / 49	45 / 50	43 / 49	45 / 50	139	150	19.0 / 64,800

¹ Minimum Circuit Ampacity @ 208 / 240 V
² Maximum Overcurrent Protection Device @ 208 / 240 V
 * Revision level that may or may not be designated
 C Circuit breaker option

HKP-15C and HKP-20C replace HKR-15C and HKR-20C respectively to meet new UL1995 requirements.

*PCH/*PHH3(24-60) Models (0 - 0.5 E.S.P.)					
Unit Model Number	Electric Heat KW				
	5	8	10	15	20
[*PCH/*PHH]32441**	T3	T3	T3	NA	NA
[*PCH/*PHH]33041**	T3	T3	T3	T5	NA
[*PCH/*PHH]33641**	T3	T3	T3	T5	NA
[*PCH/*PHH]34241**	T3	T3	T3	T5	T5
[*PCH/*PHH]34841**	T3	T3	T3	T5	T3
[*PCH/*PHH]36041**	T3	T3	T3	T5	T3



*PCH/*PHH3(24-60) Models (0.5 - 0.8 E.S.P.)					
Unit Model Number	Electric Heat KW				
	5	8	10	15	20
[*PCH/*PHH]32441**	T5	T5	T5	T5	NA
[*PCH/*PHH]33041**	T5	T5	T5	T5	NA
[*PCH/*PHH]33641**	T5	T5	T5	T5	NA
[*PCH/*PHH]34241**	T5	T5	T5	T5	NA
[*PCH/*PHH]34841**	T5	T5	T5	T5	NA
[*PCH/*PHH]36041**	T5	T5	T5	T5	NA

T1 - Fan Only, T2 - Normal Speed Cooling

T3 - Normal Speed Heating

T4 - High Speed Cooling, T5 - High Speed Cooling

MAINTENANCE

 WARNING
<p>HIGH VOLTAGE! DISCONNECT ALL POWER BEFORE SERVICING OR INSTALLING THIS UNIT. MULTIPLE POWER SOURCES MAY BE PRESENT. FAILURE TO DO SO MAY CAUSE PROPERTY DAMAGE, PERSONAL INJURY OR DEATH.</p> 

The Self Contained Package Air Conditioner and Heat Pump should operate for many years without excessive service calls if the unit is installed properly. However it is recommended that the homeowner inspect the unit before a seasonal start up. The coils should be free of debris so adequate airflow is achieved. The return and supply registers should be free of any obstructions. The filters should be cleaned or replaced. These few steps will help to keep the product up time to a maximum. The Troubleshooting Chart (on page 16) should help in identifying problems if the unit does not operate properly.

SERVICE

THE FOLLOWING INFORMATION IS FOR USE BY QUALIFIED SERVICE AGENCY ONLY: OTHERS SHOULD NOT ATTEMPT TO SERVICE THIS EQUIPMENT.

Common Causes of Unsatisfactory Operation of Heat Pump on the Heating Cycle.

INADEQUATE AIR VOLUME THROUGH INDOOR COIL

When a heat pump is in the heating cycle, the indoor coil is functioning as a condenser. The return air filter must always be clean, and sufficient air volume must pass through the indoor coil to prevent excessive discharge pressure, and high pressure cut out.

OUTSIDE AIR INTO RETURN DUCT

Do not introduce cold outside air into the return duct of a heat pump installation. Do not allow air entering the indoor coil to drop below 65°F. Air below this temperature will cause low discharge pressure, thus low suction pressure, and excessive defrost cycling resulting in low heating output. It may also cause false defrosting.

UNDERCHARGE

An undercharged heat pump on the heating cycle will cause low discharge pressure resulting in low suction pressure and frost accumulation on the outdoor coil.

POOR "TERMINATING" SENSOR CONTACT

The unit's defrost terminating sensor must make good thermal contact with the outdoor coil tubing. Poor contact may not terminate the unit's defrost cycle quickly enough to prevent the unit from cutting out on high discharge pressure.

MALFUNCTIONING REVERSING VALVE

This may be due to:

1. **Solenoid not energized** - In order to determine if the solenoid is energized, touch the nut that holds the solenoid cover in place with a screwdriver. If the nut magnetically holds the screwdriver, the solenoid is energized and the unit is in the cooling cycle.
2. **No voltage at unit's solenoid** - Check unit voltage. If no voltage, check wiring circuit.
3. **Valve will not shift:**
 - a. **Undercharged** - check for leaks;
 - b. **Valve Body Damaged** - Replace valve;
 - c. **Unit Properly Charged** - If it is on the heating cycle, raise the discharge pressure by restricting airflow through the indoor coil. If the valve does not shift, tap it lightly on both ends with a screwdriver handle. Do Not Tap The Valve Body. If the unit is on the cooling cycle, raise the discharge pressure by restricting airflow through the outdoor coil. If the valve does not shift after the above attempts, cut the unit off and wait until the discharge and suction pressure equalize, and repeat above steps. If the valve does not shift, replace it.

***PCH3[24-60]41 BLOWER PERFORMANCE**

*PCH3[24-60]41 BLOWER PERFORMANCE											
Model	Speed	Volts		NEW E.S.P. (In. of H ₂ O)							
				0.1	0.2	0.3	0.4	0.5	0.6	0.7	0.8
*PCH32441**	T1	230	CFM	922	873	823	774	724	675	626	576
			Watts	74	85	96	107	118	129	140	151
	T2 / T3	230	CFM	1172	1121	1068	1012	953	892	832	762
			Watts	135	145	155	164	175	186	184	203
	T4 / T5	230	CFM	1231	1179	1127	1074	1022	969	917	865
			Watts	168	180	193	205	2108	230	243	255
*PCH33041**	T1	230	CFM	864	808	757	695	636	567	494	437
			Watts	72	82	91	103	107	115	123	131
	T2 / T3	230	CFM	1323	1270	1220	1171	1119	1060	997	945
			Watts	179	190	199	209	219	230	240	248
	T4 / T5	230	CFM	1404	1362	1321	1271	1238	1191	1150	1105
			Watts	235	246	257	272	284	289	300	309
*PCH33641**	T1	230	CFM	1161	1113	1076	1034	994	949	889	837
			Watts	139	150	163	172	184	194	207	218
	T2 / T3	230	CFM	1379	1343	1305	1265	1226	1190	1148	1108
			Watts	216	229	241	254	264	276	285	296
	T4 / T5	230	CFM	1542	1502	1462	1427	1392	1352	1316	1280
			Watts	291	301	314	327	339	349	359	371
*PCH34241**	T1	230	CFM	1271	1214	1167	1127	1095	1052	1013	971
			Watts	168	177	188	200	214	224	235	249
	T2 / T3	230	CFM	1491	1451	1406	1369	1335	1295	1262	1226
			Watts	245	258	268	281	294	305	318	330
	T4 / T5	230	CFM	1736	1679	1638	1598	1558	1520	1484	1441
			Watts	356	372	382	395	408	422	433	442
*PCH34841**	T1	230	CFM	1337	1297	1218	1155	1118	1088	1022	989
			Watts	179	190	203	210	225	243	249	268
	T2 / T3	230	CFM	1758	1715	1674	1637	1596	1557	1518	1474
			Watts	394	406	418	430	443	455	466	474
	T4 / T5	230	CFM	2002	1935	1885	1827	1767	1732	1669	1618
			Watts	498	521	516	534	551	567	571	574
*PCH36041**	T1	230	CFM	1418	1357	1315	1274	1239	1193	1148	1102
			Watts	212	219	227	236	243	252	266	275
	T2 / T3	230	CFM	1862	1812	1763	1719	1685	1649	1615	1583
			Watts	437	447	454	461	473	480	483	493
	T4 / T5	230	CFM	1933	1886	1838	1796	1759	1723	1693	1669
			Watts	491	499	506	519	527	534	539	550

***PHH3[24-60]41 BLOWER PERFORMANCE**

*PHH3[24-60]41 BLOWER PERFORMANCE											
Model	Speed	Volts		NEW E.S.P. (In. of H ₂ O)							
				0.1	0.2	0.3	0.4	0.5	0.6	0.7	0.8
*PHH32441**	T1	230	CFM	922	873	823	774	724	675	626	576
			Watts	74	85	96	107	118	129	140	151
	T2 / T3	230	CFM	1172	1121	1068	1012	953	892	832	762
			Watts	135	145	155	164	175	186	184	203
	T4 / T5	230	CFM	1231	1179	1127	1074	1022	969	917	865
			Watts	168	180	193	205	2108	230	243	255
*PHH33041**	T1	230	CFM	864	808	757	695	636	567	494	437
			Watts	72	82	91	103	107	115	123	131
	T2 / T3	230	CFM	1323	1270	1220	1171	1119	1060	997	945
			Watts	179	190	199	209	219	230	240	248
	T4 / T5	230	CFM	1404	1362	1321	1271	1238	1191	1150	1105
			Watts	235	246	257	272	284	289	300	309
*PHH33641**	T1	230	CFM	1161	1113	1076	1034	994	949	889	837
			Watts	139	150	163	172	184	194	207	218
	T2 / T3	230	CFM	1379	1343	1305	1265	1226	1190	1148	1108
			Watts	216	229	241	254	264	276	285	296
	T4 / T5	230	CFM	1542	1502	1462	1427	1392	1352	1316	1280
			Watts	291	301	314	327	339	349	359	371
*PHH34241**	T1	230	CFM	1271	1214	1167	1127	1095	1052	1013	971
			Watts	168	177	188	200	214	224	235	249
	T2 / T3	230	CFM	1491	1451	1406	1369	1335	1295	1262	1226
			Watts	245	258	268	281	294	305	318	330
	T4 / T5	230	CFM	1736	1679	1638	1598	1558	1520	1484	1441
			Watts	356	372	382	395	408	422	433	442
*PHH34841**	T1	230	CFM	1337	1297	1218	1155	1118	1088	1022	989
			Watts	179	190	203	210	225	243	249	268
	T2 / T3	230	CFM	1758	1715	1674	1637	1596	1557	1518	1474
			Watts	394	406	418	430	443	455	466	474
	T4 / T5	230	CFM	2002	1935	1885	1827	1767	1732	1669	1618
			Watts	498	521	516	534	551	567	571	574
*PHH36041**	T1	230	CFM	1418	1357	1315	1274	1239	1193	1148	1102
			Watts	212	219	227	236	243	252	266	275
	T2 / T3	230	CFM	1862	1812	1763	1719	1685	1649	1615	1583
			Watts	437	447	454	461	473	480	483	493
	T4 / T5	230	CFM	1933	1886	1838	1796	1759	1723	1693	1669
			Watts	491	499	506	519	527	534	539	550

NOTES:

1. Data shown is dry coil. Wet coil pressure drop is approx.
2. Data shown does not include filter pressure drop, approx. 0.08" H₂O.
3. Reduce airflow by 2% for 208V operation.

TROUBLESHOOTING CHART



WARNING

HIGH VOLTAGE!

DISCONNECT ALL POWER BEFORE SERVICING OR INSTALLING THIS UNIT. MULTIPLE POWER SOURCES MAY BE PRESENT. FAILURE TO DO SO MAY CAUSE PROPERTY DAMAGE, PERSONAL INJURY OR DEATH.



SYMPTOM	POSSIBLE CAUSE	REMEDY
High head - low suction	a. Restriction in liquid line or flowrator	a. Remove or replace with proper size flowrator.
High head - high or normal suction	a. Dirty condenser coil b. Overcharged c. Condenser fan not running	a. Clean coil b. Correct System charge c. Repair or Replace
Low head - high suction	a. Incorrect flowrator b. Defective compressor valves c. Flowrator not seating properly	a. Replace with correct flowrator b. Replace compressor c. Check for debris under flowrator or deformed flowrator. Remove debris or replace flowrator.
Unit will not run	a. Power off or loose electrical connection b. Thermostat out of calibration set too high c. Defective contactor d. Blown fuses or tripped breaker e. Transformer defective f. High or low pressure control open (Optional) g. Compressor overload contacts open	a. Check for unit voltage at contactor in unit b. Reset c. Check for 24 volts at contactor coil replace if contacts are open d. Replace fuse or reset breaker Check wiring - replace transformer f. Reset high pressure control or check unit charge High pressure control opens at 610 psig Low pressure control opens at 22 psig g. Replace compressor NOTE: Wait at least 2 hours for overload to reset
Condenser fan runs, compressor doesn't	a. Loose connection b. Compressor stuck, grounded or open winding open internal overload c. Low voltage connection d. Capacitor weak, open, or shorted	a. Check for unit voltage at compressor check & tighten all connections b. Wait at least 2 hours for overload to reset If still open, replace the compressor. c. At compressor terminals, voltage must be within 10 % of nameplate volts when unit is operating d. Check capacitor. If defective, replace.
Low suction - cool compressor Iced evaporator coil	a. Low indoor airflow	a. Increase speed of blower or reduce restriction - replace air filters
Compressor short cycles	a. Defective overload protector b. Unit cycling on low pressure control c. High pressure switch cuts out	a. Replace - check for correct voltage b. Check refrigerant charge and / or airflow c. Check airflow (Indoor & outdoor)
Registers sweat	a. Low airflow	a. Increase speed of blower or reduce restriction replace air filters
High suction pressure	a. Excessive load b. Defective compressor c. Reversing valve not seating properly.	a. Recheck load calculation b. Replace c. Replace
Insufficient cooling	a. Improperly sized unit b. Improper airflow c. Incorrect refrigerant charge. d. Incorrect voltage	a. Recalculate load b. Check - should be approximately 400 CFM per ton c. Charge per procedure attached to unit service panel d. At compressor terminals, voltage must be within 10% of nameplate volts when unit is operating
Evaporator coil freezing or frosting	a. Low airflow b. Low refrigerant charge c. Operating unit in cooling mode below 65°F outdoor temperature	a. Check - should be approximately 400 CFM per ton, dirty air filters, all duct outlets open b. Properly charge unit c. Install or check low ambient control, should be open below 65°F outdoor temperature

UNIT DIMENSIONS *PCH3

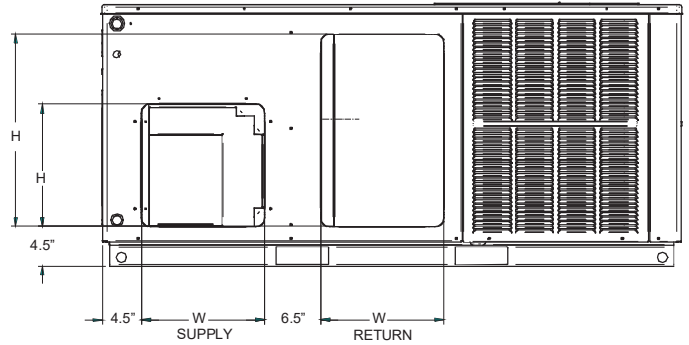
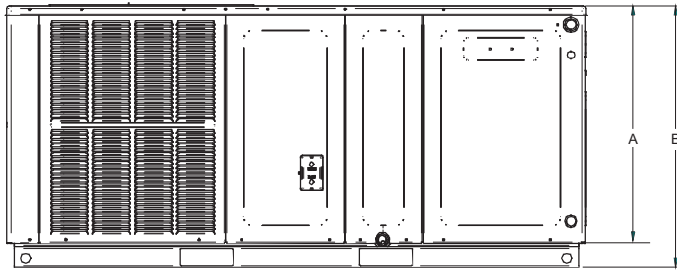
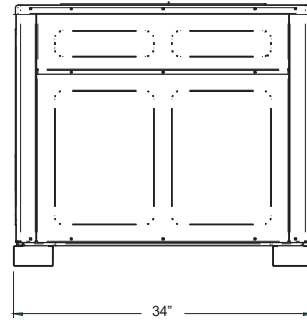
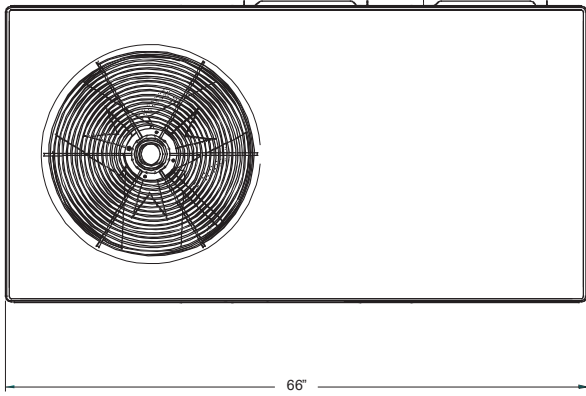

BACK VIEW
(DUCT OPENINGS)

Minimal Clearances

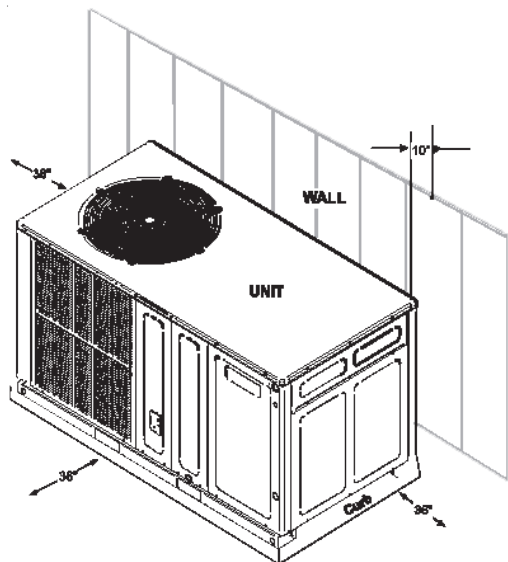

Model	Unit Dimensions				Chassis Size
			Height		
	W	D	A	B	
*PCH32441**	66	34	27½	30	Small
*PCH33041**	66	34	27½	30	Small
PCH33641	66	34	27½	30	Small
*PCH34241**	66	34	32½	35	Medium
*PCH34841**	66	34	32½	35	Medium
*PCH36041**	66	34	32½	35	Medium

Model	Duct Openings			
	Supply		Return	
	W	H	W	H
*PCH32441**	14	14	14	22
*PCH33041**	14	14	14	22
*PCH33641**	14	14	14	22
*PCH34241**	14	14	14	22
*PCH34841**	14	14	14	24
*PCH36041**	14	14	14	24

UNIT DIMENSIONS *PHH3

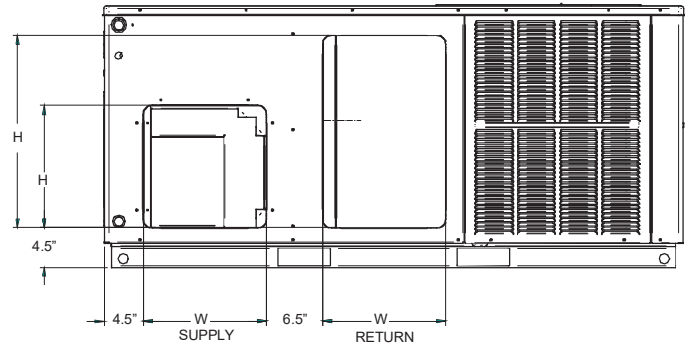
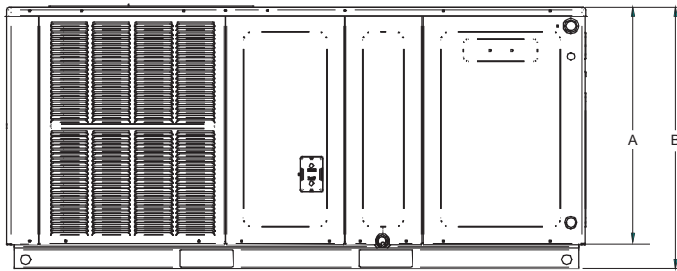
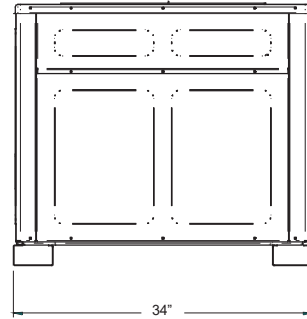
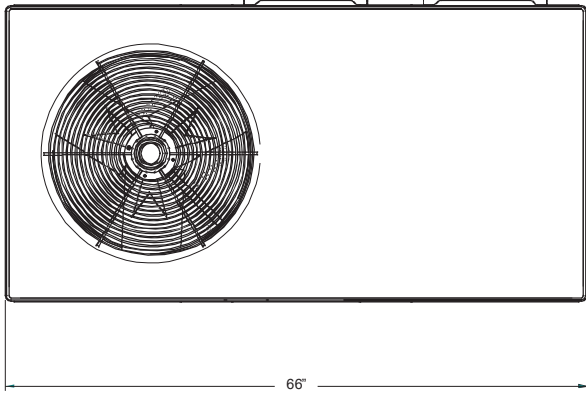

BACK VIEW
(DUCT OPENINGS)

Minimal Clearances

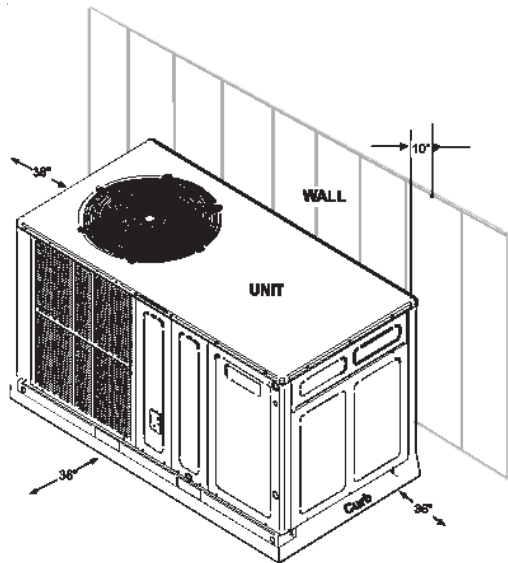



Model	Unit Dimensions				Chassis Size
			Height		
	W	D	A	B	
*PHH32441**	66	34	27½	30	Small
*PHH33041**	66	34	27½	30	Small
PHH33641	66	34	32½	35	Medium
*PHH34241**	66	34	32½	35	Medium
*PHH34841**	66	34	32½	35	Medium
*PHH36041**	66	34	36	38½	Large

Model	Duct Openings			
	Supply		Return	
	W	H	W	H
*PHH32441**	14	14	14	22
*PHH33041**	14	14	14	22
*PHH33641**	14	14	14	24
*PHH34241**	14	14	14	24
*PHH34841**	14	14	14	24
*PHH36041**	14	14	14	24

PACKAGE UNITS - HEAT PUMP AND AC UNITS HOMEOWNER'S ROUTINE MAINTENANCE RECOMMENDATIONS

We strongly recommend a bi-annual maintenance checkup be performed by a qualified service agency before the heating and cooling seasons begin.

	WARNING
HIGH VOLTAGE! DISCONNECT ALL POWER BEFORE SERVICING OR INSTALLING THIS UNIT. MULTIPLE POWER SOURCES MAY BE PRESENT. FAILURE TO DO SO MAY CAUSE PROPERTY DAMAGE, PERSONAL INJURY OR DEATH.	

REPLACE OR CLEAN FILTER

IMPORTANT NOTE: NEVER OPERATE UNIT WITHOUT A FILTER INSTALLED AS DUST AND LINT WILL BUILD UP ON INTERNAL PARTS RESULTING IN LOSS OF EFFICIENCY, EQUIPMENT DAMAGE AND POSSIBLE FIRE.

A RETURN AIR FILTER IS NOT SUPPLIED WITH THIS UNIT; HOWEVER, THERE MUST BE A MEANS OF FILTERING THE RETURN AIR. AN INDOOR AIR FILTER MUST BE USED WITH YOUR COMFORT SYSTEM. A PROPERLY MAINTAINED FILTER WILL KEEP THE INDOOR COIL OF YOUR COMFORT SYSTEM CLEAN. A DIRTY COIL COULD CAUSE POOR OPERATION AND/OR SEVERE EQUIPMENT DAMAGE.

The installer of your unit can tell you where your filter(s) are and how to clean or replace them.

Check your return filter(s) at least once every two months. When they are dirty, replace or clean as required. Disposable type filters should be replaced. Reusable type filters may be cleaned.

NOTE: REUSABLE TYPE FILTERS SHOULD BE WASHED WITH WARM WATER, DRIED COMPLETELY AND SPRAYED WITH AN ADHESIVE ACCORDING TO THE MANUFACTURERS RECOMMENDATIONS.

You may want to ask your dealer about high efficiency filters. High efficiency filters are available in both electronic and non-electronic types. These filters can do a better job of catching small airborne particles.

Improper filter maintenance is the most common cause of inadequate heating or cooling performance. Filters should be cleaned (permanent) or replaced (disposable) every two months or as required. When replacing a filter, it must be replaced with a filter of the same type and size and always make certain the air flow arrows on the filter point in the proper direction.

CONDENSER AND EVAPORATOR MOTORS

The bearings on the air circulating blower motor and condenser motor are permanently lubricated and require no further lubrication.

COMPRESSOR

The compressor motor is hermetically sealed and does not require additional oiling.

ALUMINUM INDOOR COIL CLEANING (QUALIFIED SERVICER ONLY)

This unit is equipped with an aluminum tube evaporator coil. The safest way to clean the evaporator coil is to simply flush the coil with water. This cleaning practice remains as the recommended cleaning method for both copper tube and aluminum tube residential cooling coils.

An alternate cleaning method is to use one of the products listed in the technical publication TP-109 (shipped in the literature bag with the unit) to clean the coils. The cleaners listed are the only agents deemed safe and approved for use to clean round tube aluminum coils. TP-109 is available on the web site in Partner Link > Service Toolkit.

NOTE: ENSURE COILS ARE RINSED WELL AFTER USE OF ANY CHEMICAL CLEANERS.

ANNUAL INSPECTION (QUALIFIED SERVICER ONLY)

Your package unit should be inspected by a qualified installer, or service agency at least twice every year. This check should be performed before the heating and cooling seasons begin. This will ensure that the system is performing properly and safely. Repair as necessary.

- Check physical support of the unit. Ensure it is sound without any sagging, cracks, or gaps, around the base.
- Check for obvious signs of deterioration of the unit.
- Check both condenser and evaporator coil to make sure each are clean.
- Return Air Connection. Check for physical soundness and ensure that the connection is firmly sealed to the package unit casing.
- Wiring. Check wires for damage. Check electrical connections for tightness and/or corrosion.
- Filters. Check that filters are clean and in the proper placement in the unit or duct system.
- Louvers. Inspect air inlet louvers inside the heat exchanger compartments. Ensure the area is clean and free of dirt and debris.

BEFORE CALLING YOUR SERVICER

- Check the thermostat to confirm that it is properly set.
- Check the disconnect switch near the unit to confirm that it is closed.
- Check the electrical panel for tripped circuit breakers or failed fuses. Reset the circuit breakers or replace fuses as necessary.
- Check for blockage of the indoor air inlets and outlets. Confirm that they are open and have not been blocked by objects (rugs, curtains or furniture).
- Check for obstructions on the unit. Confirm that it has not been covered on the sides or the top. Remove any obstruction that can be safely removed. If the unit is covered with dirt or debris, call a qualified servicer to clean it.
- Check the filter. If it is dirty, clean or replace it.

START-UP CHECKLIST

Residential Package - (Indoor Section)			
	Model Number		
	Serial Number		
ELECTRICAL			
Line Voltage (Measure L1 and L2 Voltage)	L1 - L2		
Secondary Voltage (Measure Transformer Output Voltage)	R - C		
Blower Amps			
Heat Strip 1 - Amps			
Heat Strip 2 - Amps			
BLOWER EXTERNAL STATIC PRESSURE			
Return Air Static Pressure			IN. W.C.
Supply Air Static Pressure			IN. W.C.
Total External Static Pressure (Ignoring +/- from the reading above, add total here)			IN. W.C.
TEMPERATURES			
Return Air Temperature (Dry bulb / Wet bulb)			DB °F WB °F
Cooling Supply Air Temperature (Dry bulb / Wet bulb)			DB °F WB °F
Heating Supply Air Temperature			DB °F
Temperature Rise			DB °F
Delta T (Difference between Supply and Return Temperatures)			DB °F
GAS PRESSURES			
Gas Inlet Pressure			IN. W.C.
Gas Manifold Pressure (Low Fire)			IN. W.C.
Gas Manifold Pressure (High Fire)			IN. W.C.
Gas Type (NG) = Natural Gas / (LP) = Liquid Propane			
Residential Package - (Outdoor Section)			
ELECTRICAL			
Supply Voltage (Measure L1 and L2 Voltage)	L1 - L2		
Compressor Amps			
Condenser Fan Amps			
PRESSURES / TEMPERATURES			
Suction Circuit (Pressure / Suction Line Temperature)	PSIG		TEMP °F
Liquid Circuit (Pressure / Liquid Temperature)	PSIG		TEMP °F
Outdoor Air Temperature (Dry bulb / Wet bulb)			DB °F WB °F
SUPERHEAT / SUBCOOLING			
	SH		SC
Additional Checks			
Check wire routings for any rubbing			
Check product for proper draining			
Check for kinked pressure switch tubing.			
Check flue elbow for alignment and clamp tightness.			
Check screw tightness on blower wheel.			
Check factory wiring and wire connections.			
Check screw tightness on Outdoor Motor and Blade			
Check product for proper clearances as noted by installtion instructions			
°F to °C formula: (°F - 32) divided by 1.8 = °C °C to °F formula: (°C multiplied by 1.8) + 32 = °F			

THIS PAGE IS LEFT INTENTIONALLY BLANK.

CUSTOMER FEEDBACK

We are very interested in all product comments.
Please fill out the feedback form on one of the following links:
Goodman® Brand Products: (<http://www.goodmanmfg.com/about/contact-us>).
Amana® Brand Products: (<http://www.amana-hac.com/about-us/contact-us>).
You can also scan the QR code on the right for the product brand
you purchased to be directed to the feedback page.



GOODMAN® BRAND



AMANA® BRAND

PRODUCT REGISTRATION

Thank you for your recent purchase. Though not required to get the protection of the standard warranty, registering your product is a relatively short process, and entitles you to additional warranty protection, except that failure by California and Quebec residents to register their product does not diminish their warranty rights.

For Product Registration, please register as follows:
Goodman® Brand products: (<https://www.goodmanmfg.com/product-registration>).
Amana® Brand products: (<http://www.amana-hac.com/product-registration>).
You can also scan the QR code on the right for the product brand
you purchased to be directed to the Product Registration page.



GOODMAN® BRAND



AMANA® BRAND