

High ALTITUDE NATURAL GAS CONVERSION KIT FOR 3 - 12.5 TON LIGHT COMMERCIAL ROOFTOP UNITS MODELS: DBG AND DRG INSTALLATION INSTRUCTIONS

© 2018 - 2020 **DAIKIN MANUFACTURING COMPANY, L.P.**

19001 Kermier Rd., Waller, TX 77484

www.daikincomfort.com

P/N: IOD-7089C

Date: April 2020

SAFETY CONSIDERATIONS

The following symbols and labels are used throughout this manual to indicate immediate or potential safety hazards. It is the owner's and installer's responsibility to read and comply with all safety information and instructions accompanying these symbols. Failure to heed safety information increases the risk of personal injury, property damage, and/or product damage.

ATTENTION INSTALLING PERSONNEL

As a professional installer you have an obligation to know the product better than the customer. This includes all safety precautions and related items.

Prior to actual installation, thoroughly familiarize yourself with this Instruction Manual. Pay special attention to all safety warnings. Often during installation or repair it is possible to place yourself in a position which is more hazardous than when the unit is in operation.

Remember, it is **your** responsibility to install the product safely and to know it well enough to be able to instruct a customer in its safe use.

Safety is a matter of common sense...a matter of thinking before acting. Most dealers have a list of specific good safety practices...follow them.

The precautions listed in this Installation Manual are intended as supplemental to existing practices. However, if there is a direct conflict between existing practices and the content of this manual, the precautions listed here take precedence.

DESCRIPTION

This high altitude Natural Gas conversion kit is intended to convert 3 to 12.5 ton DBG and DRG series light commercial gas package units for high altitude installation.

For high altitudes above 2,000 ft DBG and DRG series appliances require only gas orifice replacement and/or manifold pressure adjustment. For installation at altitudes below 2,000 ft conversion is not needed. For model numbers, ratings, and orifice selection see Input Rating table at the end of this IO.



RECOGNIZE THIS SYMBOL AS A SAFETY PRECAUTION.

WARNING

THIS CONVERSION KIT SHALL BE INSTALLED BY A QUALIFIED SERVICE AGENCY IN ACCORDANCE WITH THE MANUFACTURER'S INSTRUCTIONS AND ALL APPLICABLE CODES AND REQUIREMENTS OF THE AUTHORITY HAVING JURISDICTION. IF THE INFORMATION IN THESE INSTRUCTIONS IS NOT FOLLOWED EXACTLY, A FIRE, AN EXPLOSION OR PRODUCTION OF CARBON MONOXIDE MAY RESULT CAUSING PROPERTY DAMAGE, PERSONA INJURY OR LOSS OF LIFE. THE QUALIFIED SERVICE AGENCY IS RESPONSIBLE FOR THE PROPER INSTALLATION OF THIS KIT. THE INSTALLATION IS NOT PROPER AND COMPLETE UNTIL THE OPERATION OF THE CONVERTED APPLIANCE IS CHECKED AS SPECIFIED IN THE MANUFACTURER'S INSTRUCTIONS SUPPLIED WITH THE KIT.

WARNING

ONLY PERSONNEL THAT HAVE BEEN TRAINED TO INSTALL, ADJUST, SERVICE OR REPAIR (HEREINAFTER, "SERVICE") THE EQUIPMENT SPECIFIED IN THIS MANUAL SHOULD SERVICE THE EQUIPMENT. THE MANUFACTURER WILL NOT BE RESPONSIBLE FOR ANY INJURY OR PROPERTY DAMAGE ARISING FROM IMPROPER SERVICE OR SERVICE PROCEDURES. IF YOU SERVICE THIS UNIT, YOU ASSUME RESPONSIBILITY FOR ANY INJURY OR PROPERTY DAMAGE WHICH MAY RESULT. IN ADDITION, IN JURISDICTIONS THAT REQUIRE ONE OR MORE LICENSES TO SERVICE THE EQUIPMENT SPECIFIED IN THIS MANUAL, ONLY LICENSED PERSONNEL SHOULD SERVICE THE EQUIPMENT. IMPROPER INSTALLATION, ADJUSTMENT, SERVICING OR REPAIR OF THE EQUIPMENT SPECIFIED IN THIS MANUAL, OR ATTEMPTING TO INSTALL, ADJUST, SERVICE OR REPAIR THE EQUIPMENT SPECIFIED IN THIS MANUAL WITHOUT PROPER TRAINING MAY RESULT IN PRODUCT DAMAGE, PROPERTY DAMAGE, PERSONAL INJURY OR DEATH.

PROP 65 WARNING FOR CALIFORNIA CONSUMERS

WARNING

Cancer and Reproductive Harm -
www.P65Warnings.ca.gov

0140M00517-A



KIT CONTENTS

Using the following parts list, ensure that all parts included in this list are present and in an undamaged condition.

Parts List HAKT036150 (3-12.5 Ton Models)		
Part Number	Description	Qty.
0140L07032	Conversion Label	1
IOD-7089C	Installation Instructions	1
0163L00248	#35 Orifice Assembly (7 Pc's)	1
0163L00249	#36 Orifice Assembly (7 Pc's)	1
0163L00250	#37 Orifice Assembly (7 Pc's)	1
0163L00251	#38 Orifice Assembly (7 Pc's)	1
0163L00252	#39 Orifice Assembly (7 Pc's)	1
0163L00253	#40 Orifice Assembly (6 Pc's)	2
0163L00254	#41 Orifice Assembly (6 Pc's)	2
0163L00255	#42 Orifice Assembly (6 Pc's)	2
B2589901	#43 Orifice Assembly (6 Pc's)	1
B2589902	#44 Orifice Assembly (6 Pc's)	1
B4089945	#45 Orifice Assembly (6 Pc's)	1
B2589904	#46 Orifice Assembly (6 Pc's)	1
B2589905	#47 Orifice Assembly (6 Pc's)	1
B2589906	#48 Orifice Assembly (6 Pc's)	1
B2589907	#49 Orifice Assembly (6 Pc's)	1
0140M00517	WARNING LABEL	1

Required Tools and Supplies for Kit Installation	
Qty	Description
2	Pipe wrenches, properly sized to accommodate the gas piping and connectors
1	7/16" box wrench or socket wrench
1	5/16" nut driver
1	3/16" flat blade screwdriver
1	3/32" Allen wrench (for 36G valve)
1	Manometer to read inlet and outlet pressure of the gas valve (minimum range: 0"-20" WC)
	Pipe joint compound
	Gas leak detection solution like a soap and water solution. Always wipe the solution from the joints when testing is completed.

INSTALLATION



WARNING

HIGH VOLTAGE
DISCONNECT ALL ELECTRICAL POWER AND SHUT OFF GAS SUPPLY BEFORE SERVICING OR INSTALLING. MULTIPLE POWER SOURCES MAY BE PRESENT. FAILURE TO DO SO MAY CAUSE PROPERTY DAMAGE, PERSONAL INJURY, OR DEATH.



WARNING

TO AVOID THE POSSIBILITY OF EXPLOSION OR FIRE, NEVER USE A MATCH OR OPEN FLAME TO TEST FOR LEAKS.

Prior to performing this conversion, refer to the Installation & Operation Manual supplied with the unit, the latest edition of National Fuel Gas Code (NFPA54/ANSI Z223.1) or in Canada (CSA-B149.1, latest edition), and local codes to ensure that this appliance is installed correctly and in compliance with these codes/manuals.



CAUTION

SHUT OFF GAS SUPPLY FIRST, THEN DISCONNECT THE ELECTRICAL SUPPLY BEFORE PROCEEDING WITH THE CONVERSION.

1. Disconnect gas supply.
2. Disconnect power.
3. Set the room thermostat to its lowest possible setting.
4. Remove the burner access panel.
5. Loosen the gas supply ground union and remove the gas valve supply line. Use a pipe wrench as a backup to prevent damage/rotation of any controls.
6. Remove wires from the gas valve.
7. Remove the (4) sheet metal screws which fasten the gas manifold to the burner box. See Figure 1 for component location.
8. Using the 7/16" wrench, remove the existing orifices from the burner manifold.
9. Install the orifices supplied with this kit into the gas manifold. Look at sizes stamped on orifice face or side to insure that all the same are installed. Tighten these orifices adequately to prevent gas leakage. A minimum 3.5 threads engagement is required. Refer to orifice selection table for the correct burner orifices.
10. Reinstall gas manifold assembly into the unit. Re-wire gas valve.
11. Install the gas supply piping and its ground union joint using a pipe wrench. Use a pipe wrench as a backup.
12. Using a 3/32" Allen wrench, loosen the inlet pressure tap screw one (1) turn only (DO NOT REMOVE). Attach a 5/16" hose to the inlet pressure tap boss. Connect the other end of the hose to a manometer capable of reading pressure of 0 to 20 inches water column (see Figure 2).

NOTE: IF TWO MANOMETERS ARE AVAILABLE, INLET (SUPPLY) AND OUTLET (MANIFOLD) PRESSURES CAN BE MEASURED SIMULTANEOUSLY.

 WARNING
<p>TO AVOID THE POSSIBILITY OF EXPLOSION OR FIRE, NEVER USE A MATCH OR OPEN FLAME TO TEST THE GAS SUPPLY LINE, GAS VALVE INLET AND OUTLET PRESSURE AREAS.</p>

 WARNING
<p>TO AVOID THE POSSIBILITY OF EXPLOSION OR FIRE, NEVER USE A MATCH OR OPEN FLAME TO TEST THE GAS SUPPLY LINE, GAS VALVE INLET AND OUTLET PRESSURE AREAS OR THE THREADED PORTIONS OF THE BURNER ORIFICES FOR LEAKS.</p>

13. Turn on the gas supply to the unit. Using a soap and water solution, check the gas supply line and gas valve inlet pressure area for leaks. Repair any gas leaks detected.
14. Turn on the electric supply to the unit.
15. Adjust the room thermostat to obtain first stage burner operation (W1) - Low fire.
16. Measure inlet pressure and adjust if necessary. Inlet pressure should be about 7 in. WC (min.5 in. WC, max 10 in. WC).

24. Turn on the gas and electrical supply. Using a soap solution check the gas supply, gas valve inlet and outlet pressure areas, and threaded portions of the burner orifices for leaks. Repair any gas leaks detected.
25. Using the room thermostat to cycle the unit, observe a minimum of three (3) smooth ignition cycles.
26. **IMPORTANT NOTE:** Apply the conversion rating label (0140L07032) provided with the conversion kit. This label must be attached adjacent to the main rating plate.
27. Reinstall the access panels.

Natural Gas Pressure, in WC			
	Nominal	Min	Max
Supply Pressure (inlet)	7	5	10
Manifold Pressure High Stage	3.5	3.2	3.8
Manifold Pressure Low Stage	2	1.7	2.3

17. Turn off the gas and electrical supply to the unit. Remove pressure hose from the valve. Tighten pressure tap screw.
18. To measure outlet (manifold) pressure, connect manometer to the outlet pressure tap using procedure described in step 12 for inlet pressure measurement.
19. Turn on the gas and electric supply to the unit.
20. With the furnace operating in its Low-fire (W1) condition, the manifold pressure should be 2 ± 0.3 in. WC. If necessary, this pressure can be adjusted using the gas valve Low regulator adjustment screw located beneath the regulator cover screw (see Figure 3). Turn clockwise to increase and counterclockwise to decrease manifold pressure.
21. Readjust the room thermostat to obtain a second stage call for heat – High-fire (W2). The manifold pressure for the W2 condition should be 3.5 ± 0.3 in. WC. If necessary, this pressure can be adjusted using the gas valve High regulator adjustment screw located beneath the regulator cover screw (see Figure 3). Turn clockwise to increase and counterclockwise to decrease manifold pressure.
22. Replace both regulator screw covers if they were removed for pressure adjustments.
23. Turn off the gas and electrical supply to the unit. Remove pressure hose from the pressure tap and tighten the tap.

GAS INPUT (NATURAL GAS ONLY) CHECK

It is the responsibility of the contractor to adjust the gas input to the unit.

To measure the gas input use a gas meter and proceed as follows:

1. Turn off gas supply to all other appliances except the unit.
2. With the unit operating, time the smallest dial on the meter for one complete revolution. If this is a 2 cubic foot dial, divide the seconds by 2; if it is a 1 cubic foot dial, use the seconds as is. This gives the seconds per cubic foot of gas being delivered to the unit.
3. $INPUT = GAS\ HTG\ VALUE \times 3600 / SEC.\ PER\ CUBIC\ FOOT$

Example: Natural gas with a heating value of 1000 BTU per cubic foot and 34 seconds per cubic foot as determined by Step 2, then:

$$Input = 1000 \times 3600 / 34 = 106,000 \text{ BTU per Hour.}$$

NOTE: BTU CONTENT OF THE GAS SHOULD BE OBTAINED FROM THE GAS SUPPLIER. THIS MEASURED INPUT MUST NOT BE GREATER THAN SHOWN ON THE UNIT RATING PLATE.

Adjust input rate by varying the adjustment of the gas pressure regulator on the gas valve. All adjustments must be made with furnace operating at high fire and at normal operating temperature. A manometer should be connected to the gas valve to verify pressure is within the specified range (see following figures for manometer connections). Clockwise rotation of the pressure regulator screw increases pressure and gas flow rate. Turn screw counterclockwise to decrease pressure and gas flow rate. After adjustment the furnace temperature rise must be within the range specified on the unit data plate.

NOTE: THERMAL EFFICIENCY OF THE FURNACE IS A PRODUCT EFFICIENCY RATING DETERMINED UNDER CONTINUOUS OPERATING CONDITIONS INDEPENDENT OF ANY INSTALLED SYSTEM.

To connect manometer to gas valve:

1. Back outlet pressure test screw (inlet/outlet pressure boss) out one turn (counterclockwise, not more than one turn).
2. Attach a hose and manometer to the outlet pressure boss of the valve.

To remove manometer from gas valve:

1. Remove manometer hose from outlet pressure boss.
2. Turn outlet pressure test screw in to seal pressure port (clockwise, 7 in-lb. minimum).
3. Turn on electrical power and gas supply to the system.
4. Turn on system power and energize valve.

5. Using a leak detection solution or soap suds, check for leaks at pressure boss screw. Bubbles forming indicate a leak. SHUT OFF GAS AND FIX ALL LEAKS IMMEDIATELY.



WARNING

TO PREVENT UNRELIABLE OPERATION OR EQUIPMENT DAMAGE, THE GAS MANIFOLD PRESSURE MUST BE AS SPECIFIED ON THE UNIT RATING PLATE. ONLY MINOR ADJUSTMENTS SHOULD BE MADE BY ADJUSTING THE GAS VALVE PRESSURE REGULATOR.

6. Relight all other appliances turned off in step 1. Be sure all pilot burners are operating.

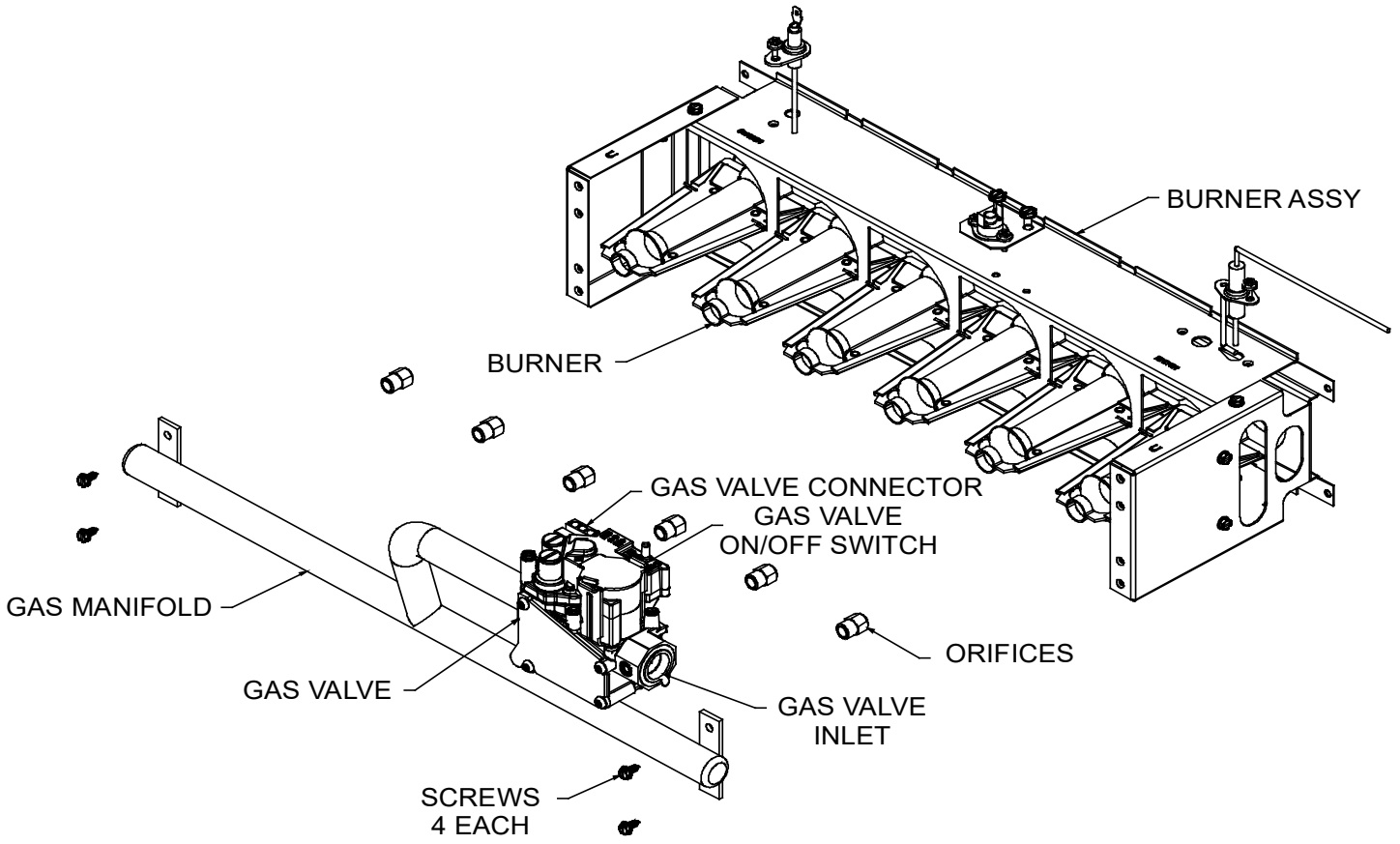

FIGURE 1

ORIFICE REPLACEMENT, 36G VALVE IS SHOWN (3 TO 6 TON MODELS). NUMBER OF ORIFICES MAY VARY DEPENDING ON MODEL.



CAUTION

SHUT OFF GAS SUPPLY FIRST, THEN DISCONNECT THE ELECTRICAL SUPPLY BEFORE PROCEEDING WITH THE CONVERSION.

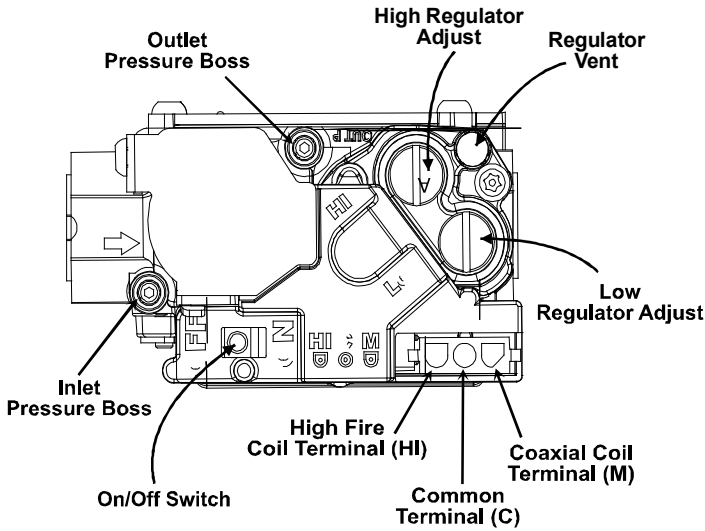

**FIGURE 2
36G VALVE FEATURES**

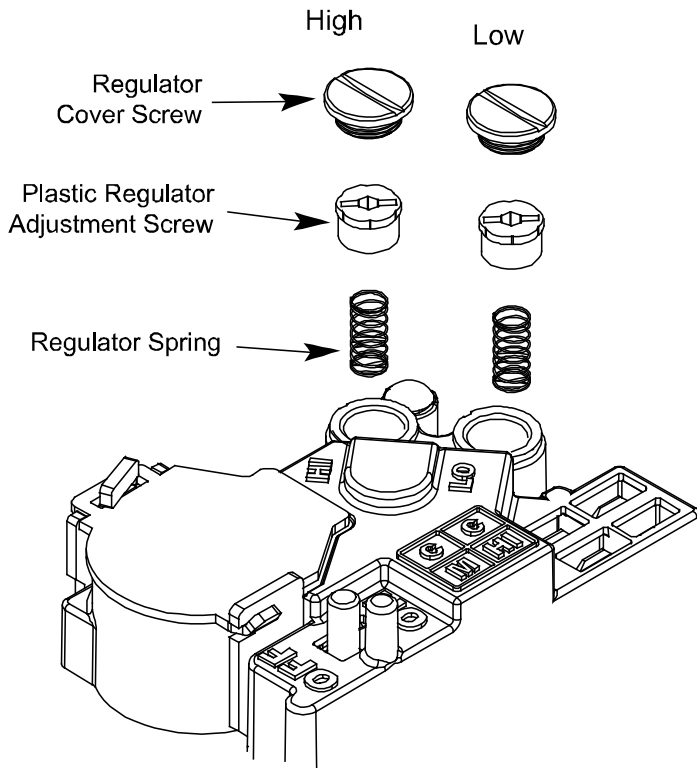

**FIGURE 3
36G TWO-STAGE VALVE PRESSURE REGULATOR**

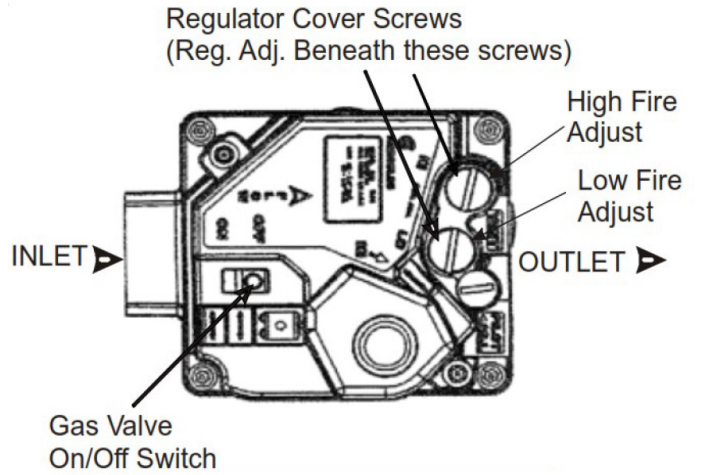

**FIGURE 4
36H VALVE FEATURES**

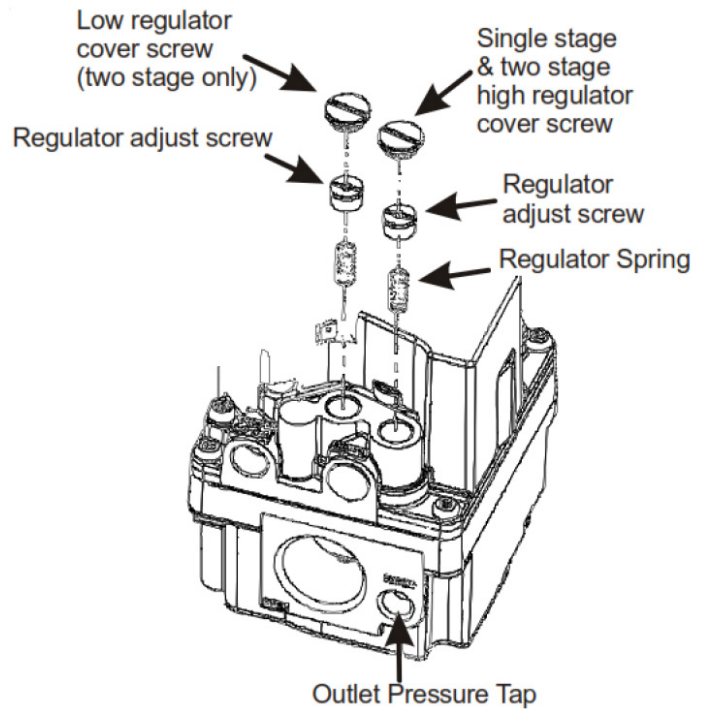

**FIGURE 5
36H TWO-STAGE VALVE PRESSURE REGULATOR**

DBG Orifice Selection Table
Orifice Sizes at Elevation (Natural Gas Only)

Ton	Model	High Fire Rate BTU/HR	Number of Burners	0 - 2,000 FT	2,000 FT	3,000 FT	4,000 FT	5,000 FT	6,000 FT	7,000 FT	8,000 FT
				N.G. Orifice Drill #	N.G. Orifice Drill #	N.G. Orifice Drill #	N.G. Orifice Drill #	N.G. Orifice Drill #	N.G. Orifice Drill #	N.G. Orifice Drill #	
3	DBG036	45,000	2	43	44	44	44	45	45	46	47
		70,000	3	43	44	44	44	45	45	46	47
		90,000	5	45	46	47	47	47	48	48	49
4	DBG048	70,000	3	43	44	44	44	45	45	46	47
		90,000	4	43	44	44	44	45	45	46	47
		115,000	5	43	44	44	44	45	45	46	47
5	DBG060	90,000	4	43	44	44	44	45	45	46	47
		115,000	5	43	44	44	44	45	45	46	47
		140,000	6	43	44	44	44	45	45	46	47
6	DBG072	90,000	4	43	44	44	44	45	45	46	47
		115,000	5	43	44	44	44	45	45	46	47
		140,000	6	43	44	44	44	45	45	46	47
7.5	DBG090	210,000	7	37	38	39	39	40	41	42	42
8.5	DBG102	210,000	7	37	38	39	39	40	41	42	42
10	DBG120	210,000	7	37	38	39	39	40	41	42	42
12.5	DBG150	210,000	7	37	38	39	39	40	41	42	42

DRG Orifice Selection Table
Orifice Sizes at Elevation (Natural Gas Only)

Ton	Model	High Fire Rate BTU/HR	Number of Burners	0 - 2,000 FT	2,000 FT	3,000 FT	4,000 FT	5,000 FT	6,000 FT	7,000 FT	8,000 FT
				N.G. Orifice Drill #	N.G. Orifice Drill #	N.G. Orifice Drill #	N.G. Orifice Drill #	N.G. Orifice Drill #	N.G. Orifice Drill #	N.G. Orifice Drill #	
3	DRG036	45,000	2	43	44	44	44	45	45	46	47
		70,000	3	43	44	44	44	45	45	46	47
		115,000	6	45	46	47	47	47	48	48	49
4	DRG048	70,000	3	43	44	44	44	45	45	46	47
		115,000	5	43	44	44	44	45	45	46	47
		140,000	6	43	44	44	44	45	45	46	47
5	DRG060	70,000	3	43	44	44	44	45	45	46	47
		115,000	5	43	44	44	44	45	45	46	47
		140,000	6	43	44	44	44	45	45	46	47
6	DRG072	70,000	3	43	44	44	44	45	45	46	47
		125,000	5	41	42	42	42	43	43	44	44
		150,000	6	41	42	42	42	43	43	44	44
7.5	DRG090	130,000	5	41	42	42	42	43	43	44	44
		180,000	6	37	38	39	39	40	41	42	42
		225,000	7	36	37	38	38	39	40	41	41
8.5	DRG102	130,000	5	41	42	42	42	43	43	44	44
		180,000	6	37	38	39	39	40	41	42	42
		225,000	7	36	37	38	38	39	40	41	41
10	DRG120	130,000	4	41	42	42	42	43	43	44	44
		180,000	5	37	38	39	39	40	41	42	42
		240,000	7	34	35	36	36	37	37	38	39
12.5	DRG150	130,000	4	41	42	42	42	43	43	44	44
		180,000	5	37	38	39	39	40	41	42	42
		240,000	7	34	35	36	36	37	37	38	39

CUSTOMER FEEDBACK

Daikin is very interested in all product comments.

Please fill out the feedback form on the following link:

<https://daikincomfort.com/contact-us>

You can also scan the QR code on the right to be directed to the feedback page.



NOTE: SPECIFICATIONS AND PERFORMANCE DATA LISTED HEREIN ARE SUBJECT TO CHANGE WITHOUT NOTICE

Quality Makes the Difference!

All of our systems are designed and manufactured with the same high quality standards regardless of size or efficiency. We have designed these units to significantly reduce the most frequent causes of product failure. They are simple to service and forgiving to operate. We use quality materials and components. Finally, every unit is run tested before it leaves the factory.

That's why we know. . . **There's No Better Quality.**

Visit our website at www.daikincomfort.com for information on:

- Products
- Customer Services
- Contractor Program and Training
- Warranties
- Parts
- Financing Options

Our continuing commitment to quality products may mean a change in specifications without notice.

© 2018-2020 **DAIKIN MANUFACTURING COMPANY, L.P.**

19001 Kermier Rd., Waller, TX 77484

www.daikincomfort.com