

McDaniel Metals

281-987-8400 • 281-987-9494 (fax)
1318 Buschong, Houston, TX 77039
www.mcdanielmetals.com

DDNECNJ90150NR

DOWNFLOW JADE ECONOMIZER
FITS DAIKIN D*G090-150, D*H090-
150, D*C090-150 -NO RELIEF-

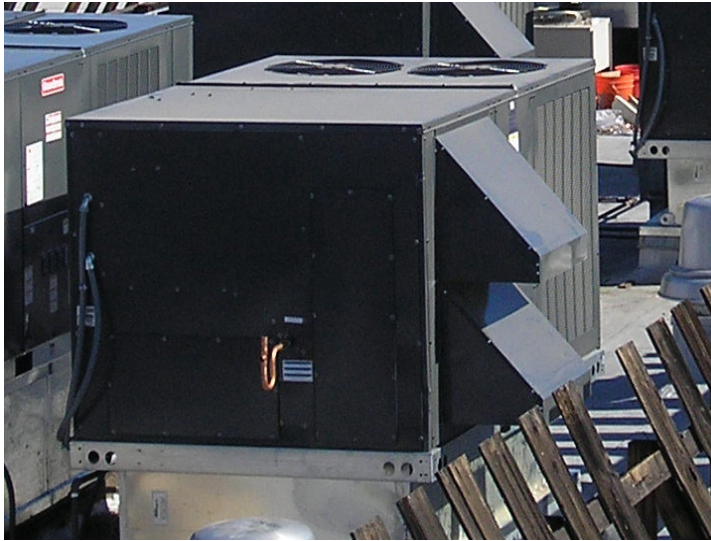

ECONOMIZER 101

Economizers are designed to provide “free” air conditioning when outside conditions are appropriate. When the outside air is cool and dry enough, the economizer automatically opens to introduce the cool air to the interior space, thereby eliminating the need to run the air conditioning compressor.

If the outside air becomes too warm or humid, the economizer automatically closes the fresh air damper and the compressor engages to begin cooling the space mechanically.

If a two stage thermostat is used it is possible to use a combination of economizer and mechanical cooling to condition the space.

The economizer can also be set to allow a minimum amount of fresh air to enter the space when the equipment’s indoor blower is operating. Economizers are valuable tools to enhance indoor air quality, save energy and prolong the life of the air conditioning equipment.

SEQUENCE OF OPERATION

This sequence assumes employment of a single enthalpy economizer using a two stage thermostat.

1. A call for cooling comes from room thermostat.
2. The enthalpy sensor determines if the atmospheric conditions are conducive for using outside air for cooling. If YES, go to step 3. If NO, or if outdoor air temperature rises above enthalpy set point, go to step 4.
3. The outside air dampers open and modulate to maintain a mixed air temperature (outside air + indoor air) of 53 degrees F. If the outdoor air is insufficient to satisfy the thermostat alone and a second stage of cooling is required, the first stage compressor starts and works in conjunction with the economizer

to cool the space. (Go to step 5.)

4. Outdoor air dampers open to minimum position and the compressor engages to provide mechanical cooling.
5. When the thermostat is satisfied the outside air dampers return to a closed position.



Figure 1

INSTALLATION

1. Open carton and inspect contents for shortages and damage.
2. Remove large evaporator access panel from package unit and discard. Remove the smaller filter access panel and the horizontal return panel.
3. Slide the damper rack into the large opening and pivot the damper into position around the post between the evaporator opening and the filter access opening. (Figure 1)
4. Position the dampers in the opening until the front flanges are flush with the corner post and divider post between the filter access panel and the evaporator access panel. (Figure 2)



Figure 2

5. Feed the pink wires for the mixed air sensor through the unit economizer plug mousehole into the blower section of the unit. Mount the mixed air sensor to the blower housing away from the center to avoid interfering with the rotation of the blower wheel and plug in the wires. (Figure 3)
6. Attach the pink mixed air sensor wires to the controller. (Figure 4)
7. From the horizontal return opening, plug 9-pin economizer plug into matching 9-pin plug in the unit.

NOTE: Ensure neither the wire nor the plugs interfere with the movement of the dampers during operation.

8. Replace the horizontal return cover.
9. Install the new evaporator access panel on the unit.
10. Secure access panel to the unit with the screws from step 2. New holes must be drilled to secure the panel to the 12.5 ton unit.
11. Assemble the barometric relief hood and the fresh air hoods with the screws provided. Be sure to install the mist eliminators before installing the front filter access piece. (Figure 6)
12. Install gasket material on the economizer panel outside of the hood openings using the hood mounting holes as a guide.
13. Refer to enclosed documentation for the Jade controller for set up.
14. Use the minimum set point equation (see below) to determine the minimum position setting on the controller.
15. Install barometric relief hood with screws provided through access panel and economizer.
16. Install the fresh air hood with the screws provided through the access panel and economizer.
17. Install the blockoff panel above the hoods on the 12.5 ton unit. (Figure 5)
18. Run a bead of silicone or other approved sealant along the hood flanges to ensure a watertight seal.
19. Replace filter access panel.

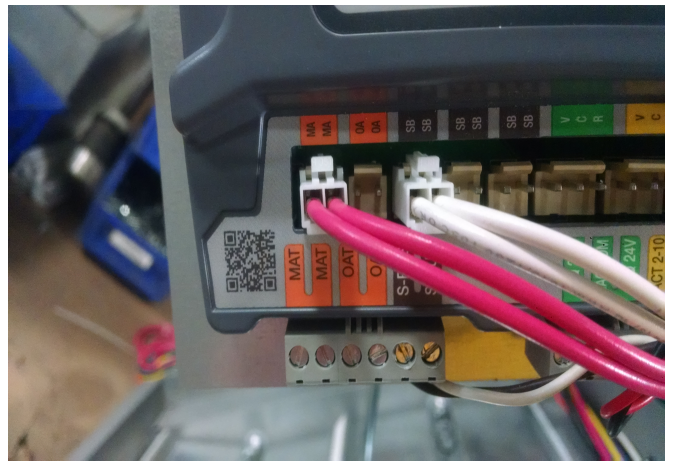

Figure 4



Figure 5

MINIMUM SET POINT EQUATION

$$(To \times OA) + (Tr \times RA) = Tm$$

To = Outdoor air temperature

OA= Percent of outdoor air

Tr = Return air temperature

RA= Percent of return air

Tm= Resulting mixed air temperature

Example:

Fresh air required is 10% outdoor air.

Outdoor air temperature is 60 degrees F.

Return air temperature is 75 degrees F.

$$(0.1 \times 60) + (0.9 \times 75) =$$

$$6.0 + 67.5 = 73.5$$

Mixed air temperature will be 73.5 degrees F when the OA is 60 degrees F and the RA is 75 degrees F with 10% outdoor air.



Figure 3

Important Notes

Please see enclosed brochure for Honeywell component trouble shooting and heat pump set up instructions.

The fresh air mist eliminator should be flushed periodically with warm soapy water.

A two stage thermostat is recommended with this accessory.



CONTENTS

| | |
|---|------------------------------------------------|
| 1 | Damper rack w/ economizer controls |
| 2 | Fresh air hood sides |
| 1 | Fresh air hood top |
| 1 | Fresh air hood filter access |
| 2 | Barometric relief hood sides |
| 1 | Barometric relief hood top |
| 1 | Barometric relief hood filter access |
| 2 | Mist eliminator |
| 1 | Evaporator Access Panel |
| 1 | Blockoff Panel for 12.5 Ton |
| 1 | Screw package |
| 1 | Installation Instructions and Component Manual |
| 1 | Gasket Material |

ACCESSORIES / CAPABILITIES

Dual Enthalpy - Requires an additional C7400 enthalpy control installed in the return air duct.

Demand Control Ventilation - Requires a CO2 sensor.

Power Exhaust - DPE90150X power exhaust used in applications where barometric relief is not sufficient.

This product is warranted to be free from defects due to workmanship or materials, under normal use, for a period of sixty (60) months from date of installation.

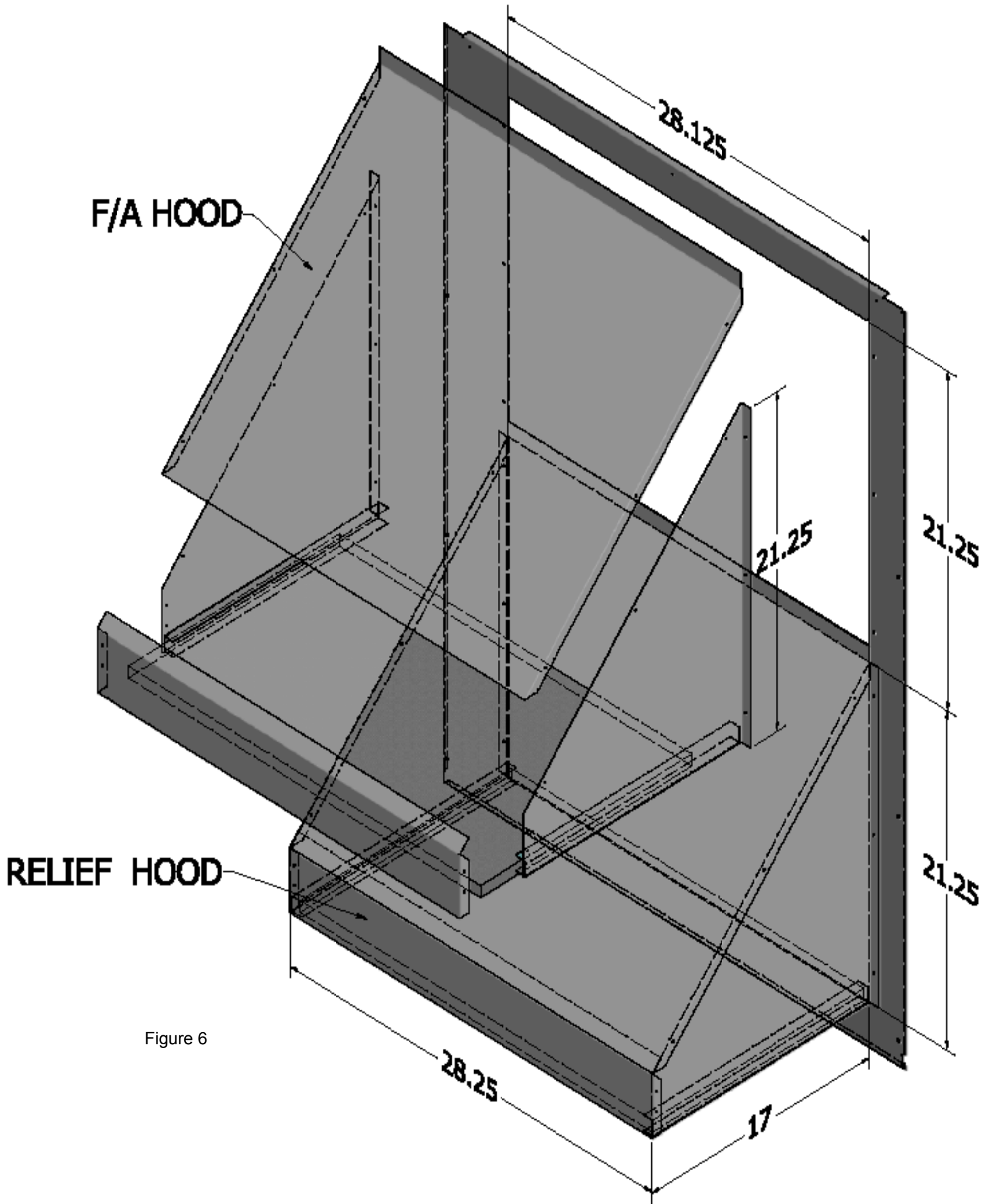

Figure 6

JADE WIRE DIAGRAM 3105 REV4

GROUND

GROUND LUG

MS3105K3052/B
HONEYWELL ACTUATOR

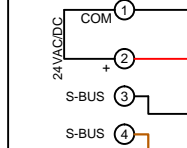

BLACK
RED
WHITE
BROWN

PINK
PINK
WHITE
WHITE
BLACK
RED

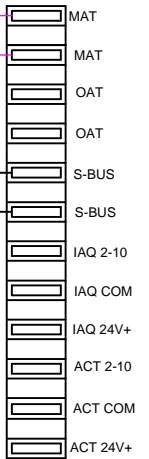

HONEYWELL
W720

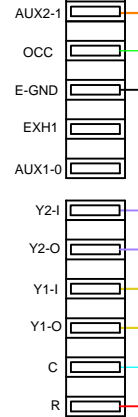

(O)
BLACK
(P)
(P)
(Y)
(Y)
(BL)
(R)

MOLEX 3597706**
50048926-002

COLOR CODES FOR 9 PIN PLUG

- ① (Y) YELLOW
- ② (P) PURPLE
- ③ (P) PURPLE
- ④ (Y) YELLOW
- ⑤ (BL) BLUE
- ⑥ (G) GREEN
- ⑧ (O) ORANGE
- ⑨ (R) RED

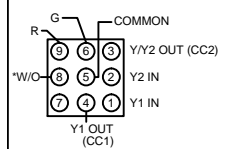

* WHITE WIRE ON DCG
ORANGE WIRE ON DCH

CONNECT TO
C7400S1000
ENTHALPY CONTROL

CONNECT TO
C7250A1001
MIXED AIR SENSOR

