



EDUS042502

R-32

Engineering Data

Split Type Air Conditioners

- Heat Pump -

FTXQ-A Series



INVERTER

Split Type Air Conditioners

FTXQ-A Series

1. Lineup	3
2. Functions	4
3. Specifications.....	5
4. Dimensions	6
4.1 Indoor Unit	6
4.2 Outdoor Unit	7
5. Wiring Diagrams	8
5.1 Indoor Unit	8
5.2 Outdoor Unit	9
6. Piping Diagrams	10
6.1 Indoor Unit	10
6.2 Outdoor Unit	11
7. Capacity Tables	12
7.1 Capacity Correction Factor by the Length of Refrigerant Piping (Reference).....	14
8. Operation Limit	15
9. Sound Level.....	16
9.1 Measuring Location	16
9.2 Indoor Unit	17
9.3 Outdoor Unit	18
10. Electric Characteristics	19
11. Installation Manual.....	20
11.1 Indoor Unit	20
11.2 Outdoor Unit	34
11.3 Flareless Joint.....	46
12. Operation Manual	48
13. Options	74
13.1 Option List.....	74
13.2 <BRC073A6> Wired Remote Controller (Installation)	75
13.3 <BRC073A6> Wired Remote Controller (Operation).....	104
13.4 <BRC944B2> Wired Remote Controller (Installation)	147
13.5 <BRC944B2> Wired Remote Controller (Operation).....	149
13.6 <BRCW901A03/08> Wired Remote Controller Cord.....	161
13.7 <KRP413BB1S> Wiring Adaptor	162
13.8 <DCS302C71> Central Remote Controller (Installation).....	166

13.9 <DCS302C71> Central Remote Controller (Operation)	171
13.10 <DCS301C71> Unified ON/OFF Controller (Installation)	197
13.11 <DCS301C71> Unified ON/OFF Controller (Operation).....	202
13.12 <DST301BA61> Schedule Timer Controller (Installation)	204
13.13 <DST301BA61> Schedule Timer Controller (Operation).....	209
13.14 <KRP928BB2S> Interface Adaptor for DIII-NET	222
13.15 <KRP067A41> Remote Control PC-Board Set	225
13.16 <KPW937F4> Air Direction Adjustment Grille	229
13.17 <KKG067A41> Back Protection Wire Net	231
13.18 <KPS067A41> Snow Hood (Side).....	232
13.19 <KPS067A42> Snow Hood (Rear)	234
13.20 <KPS067A44> Snow Hood (Discharge).....	236

1. Lineup

Indoor Unit		Outdoor Unit	Power Supply
Wall mounted type	FTXQ09ASBU9	RXQ09ASBU9	1 phase, 115 V, 60 Hz
	FTXQ12ASBU9	RXQ12ASBU9	

Note: Power Supply Intake ; Outdoor Unit

Cautions



1. Air conditioners should not be installed in areas where corrosive gasses, such as acid gas or alkaline gas, are produced.
2. If the outdoor unit is to be installed close to the sea shore, direct exposure to the sea breeze should be avoided and choose an outdoor unit with anti-corrosion treatment.

2. Functions

Category	Functions	FTXQ
Basic Function	Inverter (with inverter power control)	●
	Operation limit	Refer to P. 15
	PAM control	●
Compressor	Swing compressor	●
	Reluctance DC motor	●
Comfortable Airflow	Power-airflow flap (horizontal blade)	●
	Wide-angle louvers (vertical blades)	●
	Auto-swing (up and down)	●
	COMFORT AIRFLOW operation	●
Comfort Control	Auto fan speed	●
	Switchable fan speed	●
	Indoor unit quiet operation	●
	Hot-start function	●
	Automatic defrosting	●
Operation	Automatic cooling/heating change-over	●
	Program dry operation	●
	Fan only	●
Lifestyle Convenience	POWERFUL operation (inverter)	●
	ECONO operation	●
	Indoor unit ON/OFF switch	●
	Signal receiving sign	●
	R/C with back light	●
Health and Cleanliness	Mold proof air filter	●
	Wipe-clean flat panel	●
	Removable drain pan	●
Timer	Count up-down ON/OFF timer	●
	NIGHT SET mode	●
Worry Free (Reliability & Durability)	Auto-restart (after power failure)	●
	Self-diagnosis (Remote controller, LED)	●
Flexibility	Chargeless	49.2 ft. (15 m)
	Either side drain (left or right)	●
Remote Control	Remote control adaptor (normal open pulse contact)	Option
	Remote control adaptor (normal open contact)	Option
	DIII-NET compatible (adaptor)	Option
	Wireless LAN connection	Option
Remote Controller	Wireless	●
	Wired	Option
	°F/°C changeover R/C temperature display (factory setting: °F)	●

- : Available
 — : Not available

3. Specifications

Model	Indoor Unit		FTXQ09ASBU9		FTXQ12ASBU9	
	Outdoor Unit		RXQ09ASBU9		RXQ12ASBU9	
			Cooling	Heating	Cooling	Heating
Power Supply			1 φ, 115 V, 60 Hz		1 φ, 115 V, 60 Hz	
Capacity Rated (Min. ~ Max.)		Btu/h	9,000 (2,800 ~ 10,500)	10,900 (3,800 ~ 12,000)	12,000 (3,600 ~ 12,800)	13,500 (3,800 ~ 14,600)
Running Current (Rated)		A	7.67	9.20	10.23	10.29
Power Consumption (Rated)		W	750	908	1,000	1,015
Power Factor (Rated)		%	85.0	85.8	85.0	85.8
SEER2 / HSPF2			20.0	9.0	20.0	9.0
EER2 (Rated)		Btu/h-W	12.0	—	12.0	—
COP2@5°F (Rated)		W/W	—	1.9	—	2.1
Piping Connection	Liquid	in. (mm)	φ 1/4 (6.4)		φ 1/4 (6.4)	
	Gas	in. (mm)	φ 3/8 (9.5)		φ 3/8 (9.5)	
	Drain	in. (mm)	φ 5/8 (16)		φ 5/8 (16)	
Heat Insulation			Both Liquid and Gas Pipes		Both Liquid and Gas Pipes	
Max. Interunit Piping Length		ft (m)	65-5/8 (20)		65-5/8 (20)	
Max. Interunit Height Difference		ft (m)	49-1/4 (15)		49-1/4 (15)	
Chargeless		ft (m)	49-1/4 (15)		49-1/4 (15)	
Amount of Additional Charge of Refrigerant		oz/ft (g/m)	0.22 (20)		0.22 (20)	
Indoor Unit			FTXQ09ASBU9		FTXQ12ASBU9	
Front Panel Color			White (N9.5)		White (N9.5)	
Airflow Rates	H / M / L / SL	cfm	424 / 307 / 261 / 134	413 / 328 / 247 / 212	413 / 311 / 244 / 124	434 / 321 / 244 / 208
		m³/min	12.0 / 8.7 / 7.4 / 3.8	11.7 / 9.3 / 7.0 / 6.0	11.7 / 8.8 / 6.9 / 3.5	12.3 / 9.1 / 6.9 / 5.9
Fan	Type		Cross Flow Fan		Cross Flow Fan	
	Drive Input	A	0.36		0.42	
	Speed	Steps	5 Steps, Quiet, Auto		5 Steps, Quiet, Auto	
Air Direction Control			Right, Left, Horizontal, Downward		Right, Left, Horizontal, Downward	
Air Filter			Removable, Washable		Removable, Washable	
Running Current (Rated)		A	0.25	0.23	0.27	0.31
Power Consumption (Rated)		W	27	25	29	32
Power Factor (Rated)		%	93.0	93.9	91.9	90.4
Temperature Control			Microcomputer Control		Microcomputer Control	
Dimensions (H × W × D)		in. (mm)	11-1/4 × 30-5/16 × 8-3/4 (286 × 770 × 223)		11-1/4 × 30-5/16 × 8-3/4 (286 × 770 × 223)	
Packaged Dimensions (H × W × D)		in. (mm)	12-13/16 × 33-1/8 × 14-9/16 (325 × 842 × 370)		12-13/16 × 33-1/8 × 14-9/16 (325 × 842 × 370)	
Weight (Mass)		lbs (kg)	18 (8)		19 (9)	
Gross Weight (Gross Mass)		lbs (kg)	24 (11)		25 (12)	
Sound Pressure Level		H / M / L / SL dB(A)	43 / 35 / 30 / 21	41 / 36 / 28 / 25	46 / 38 / 31 / 21	45 / 37 / 30 / 25
Outdoor Unit			RXQ09ASBU9		RXQ12ASBU9	
Casing Color			Ivory White		Ivory White	
Heat Exchanger		Fin Spec / Tube	Waffle Fin (PE) / φ 7 Hi-XSL Tube		Waffle Fin (PE) / φ 7 Hi-XSL Tube	
Compressor		Type	Hermetically Sealed Swing Type		Hermetically Sealed Swing Type	
		Model	1Y091BKBX1A		1Y091BKBX1A	
Refrigerant Oil		Type	FW68DA		FW68DA	
		Charge	12.68 (0.375)		12.68 (0.375)	
Refrigerant		Type	R-32		R-32	
		Charge	1.15 (0.52)		1.65 (0.75)	
Airflow Rate		cfm (m³/min)	34.9 (1,233)	32.6 (1,151)	32.4 (1,144)	32.4 (1,144)
Fan		Type	Propeller		Propeller	
		Drive Input	A		0.42	
Running Current (Rated)		A	7.42	8.97	9.96	9.98
Power Consumption (Rated)		W	723	883	971	983
Power Factor (Rated)		%	84.7	85.6	84.8	85.6
Dimensions (H × W × D)		in. (mm)	21-15/16 × 26-9/16 × 11-3/16 (557 × 675 × 284)		21-15/16 × 26-9/16 × 11-3/16 (557 × 675 × 284)	
Packaged Dimensions (H × W × D)		in. (mm)	24-7/16 × 31-1/4 × 14-1/8 (620 × 794 × 359)		24-7/16 × 31-1/4 × 14-1/8 (620 × 794 × 359)	
Weight (Mass)		lbs (kg)	59 (27)		64 (29)	
Gross Weight (Gross Mass)		lbs (kg)	64 (29)		70 (32)	
Sound Pressure Level		dB(A)	48	49	50	52
Conditions Based on		Indoor	80.0°FDB (26.7°CDB) / 67.0°FWB (19.4°CWB)	70.0°FDB (21.1°CDB) / 60.0°FWB (15.6°CWB)	80.0°FDB (26.7°CDB) / 67.0°FWB (19.4°CWB)	70.0°FDB (21.1°CDB) / 60.0°FWB (15.6°CWB)
		Outdoor	95.0°FDB (35.0°CDB) / 75.0°FWB (23.9°CWB)	47.0°FDB (8.33°CDB) / 43.0°FWB (6.11°CWB)	95.0°FDB (35.0°CDB) / 75.0°FWB (23.9°CWB)	47.0°FDB (8.33°CDB) / 43.0°FWB (6.11°CWB)
		Piping Length	25 ft (7.5 m)		25 ft (7.5 m)	
Drawing No.			3D154610		3D154610	
Note			SL: The quiet fan level of the airflow rate setting.			

Conversion Formulae	
kcal/h = kW × 860	
Btu/h = kW × 3412	
cfm = m³/min × 35.3	

4. Dimensions

4.1 Indoor Unit

FTXQ09/12ASBU9

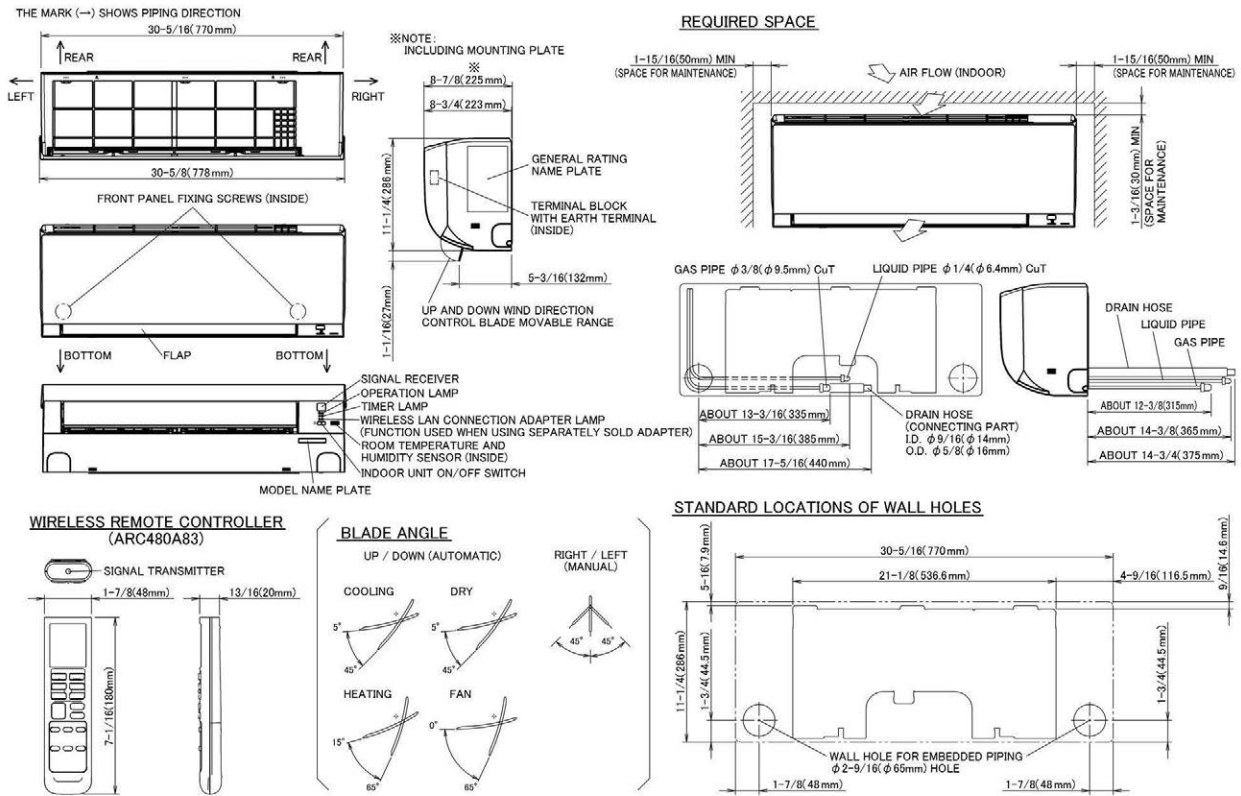

3D153988

4.2 Outdoor Unit RXQ09/12ASBU9

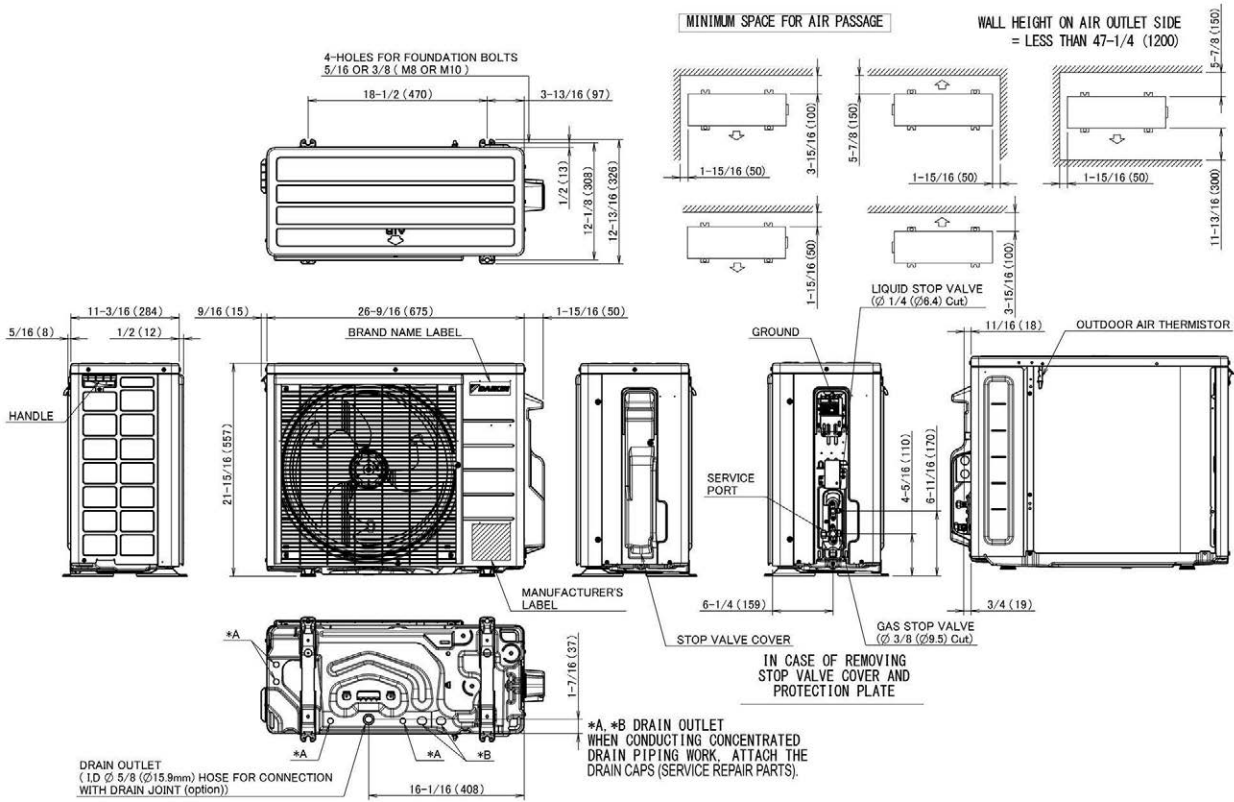

C: 3D152019

5. Wiring Diagrams

5.1 Indoor Unit FTXQ09/12ASBU9

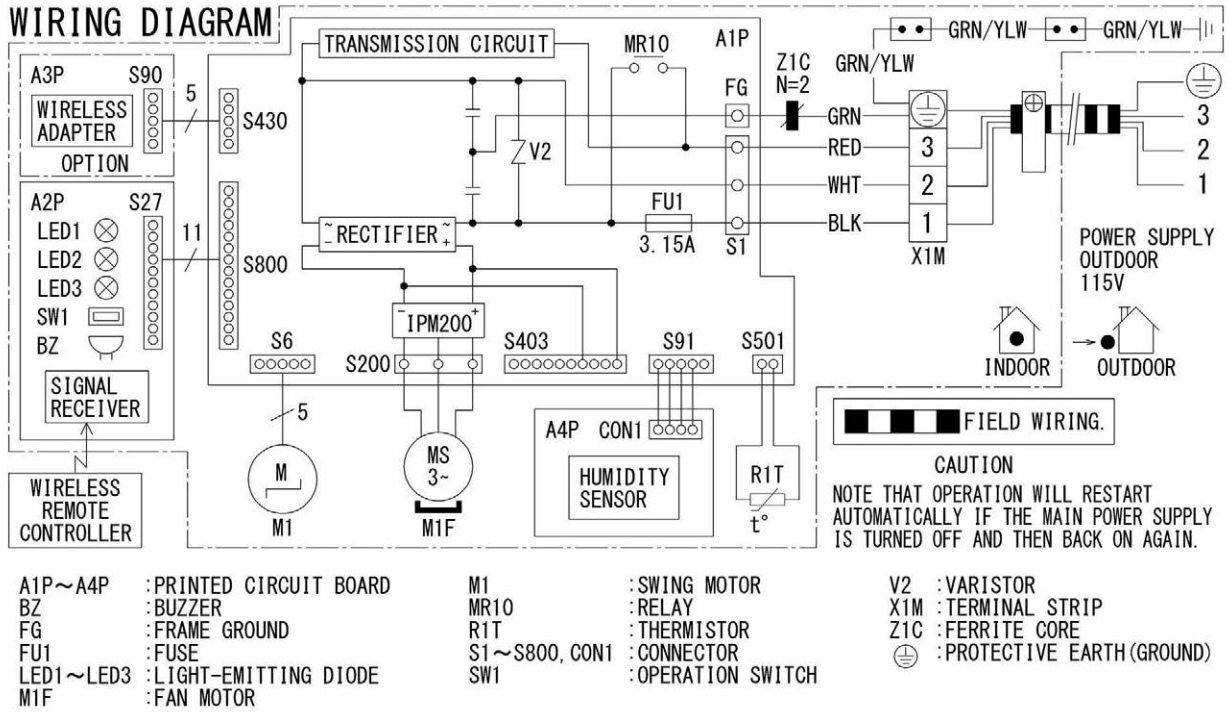

3D152536

5.2 Outdoor Unit RXQ09/12ASBU9

WIRING DIAGRAM

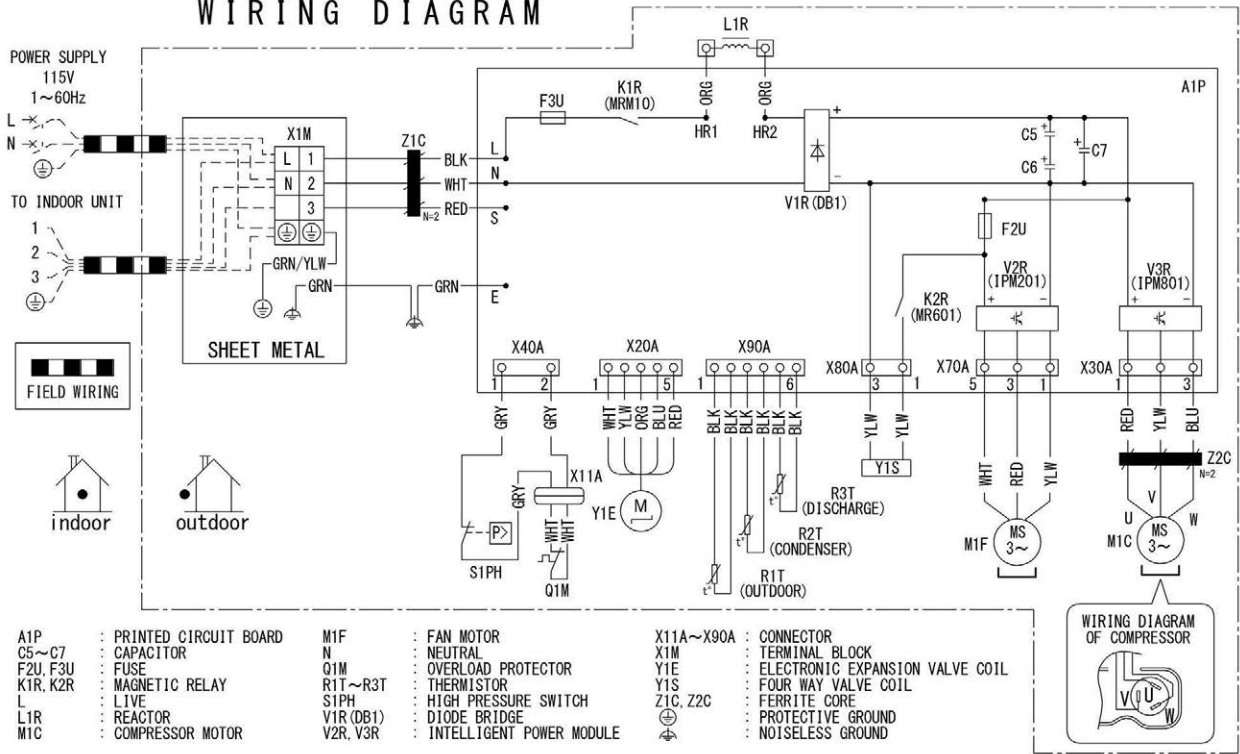

3D153370

6. Piping Diagrams

6.1 Indoor Unit FTXQ09ASBU9

FTXQ12ASBU9

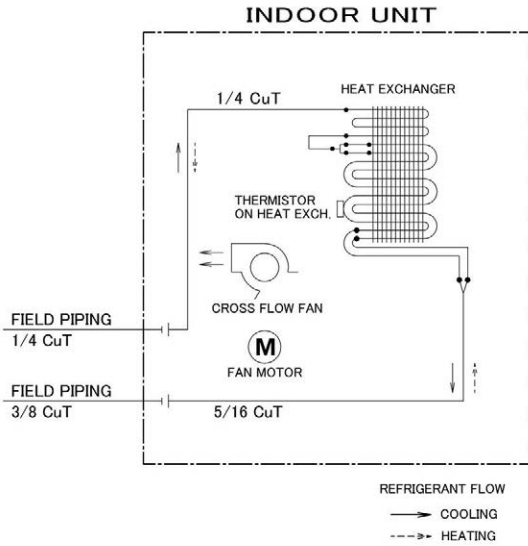

4D152532

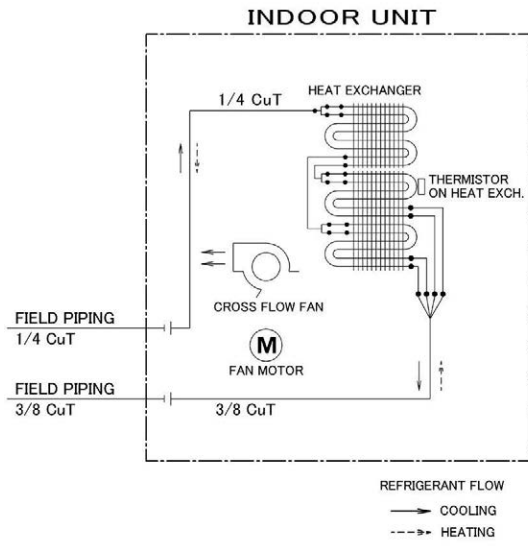

4D150950

6.2 Outdoor Unit RXQ09ASBU9

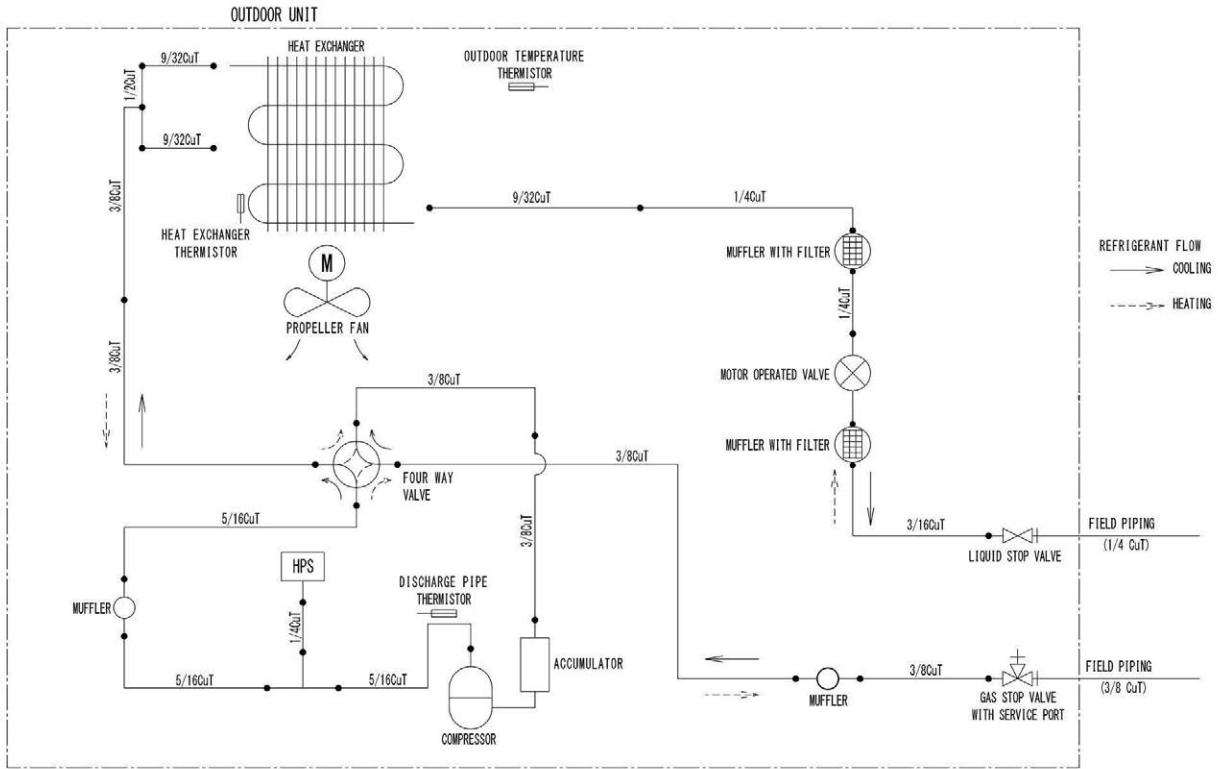

3D153768

RXQ12ASBU9

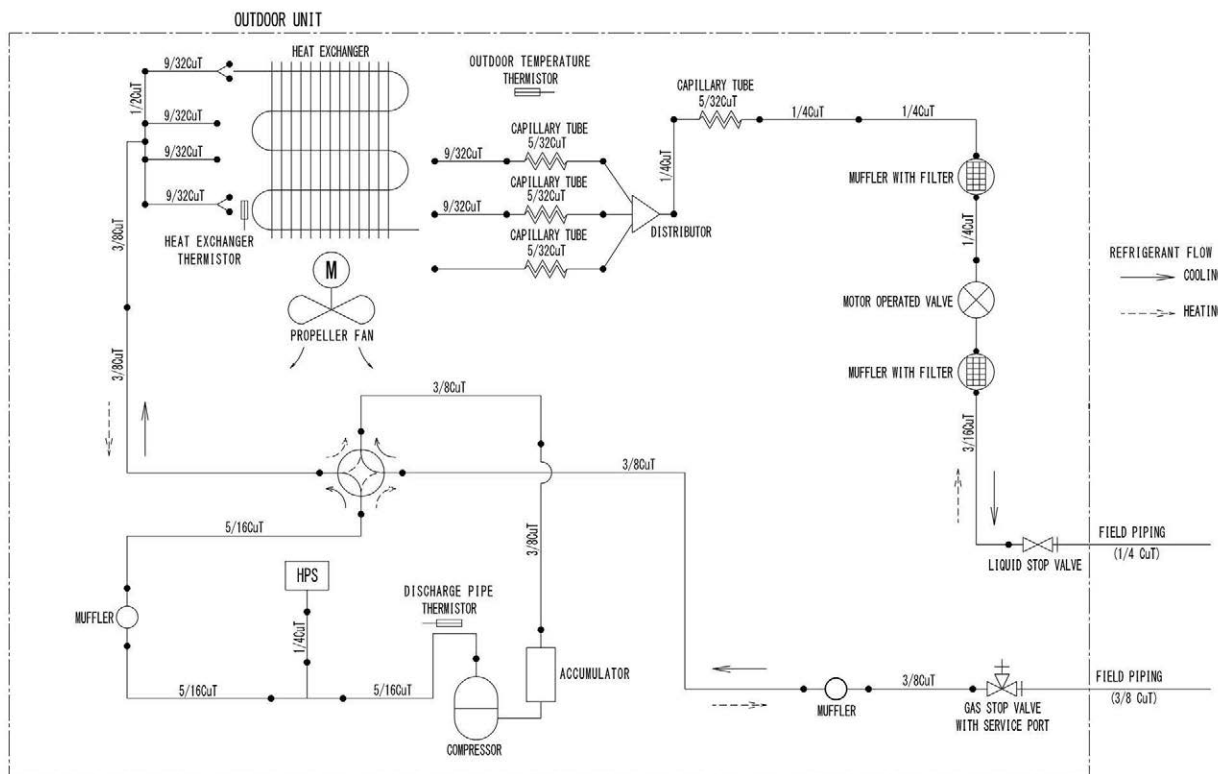

3D150194

7. Capacity Tables

FTXQ09ASBU9 + RXQ09ASBU9

Cooling (60 Hz, 115 V)

AFR	12.0
BF	0.25

Temp: Celsius / TC, SHC, PI: kW

INDOOR		OUTDOOR TEMPERATURE (°CDB)																	
EWB	EDB	10			20			30			35			40			46		
		TC	SHC	PI	TC	SHC	PI	TC	SHC	PI	TC	SHC	PI	TC	SHC	PI	TC	SHC	PI
14.0	20.0	3.41	2.59	0.68	3.12	2.44	0.85	2.84	2.31	1.01	2.69	2.24	1.09	2.55	2.17	1.11	2.38	2.09	0.80
16.0	22.0	3.55	2.54	0.69	3.27	2.40	0.85	2.98	2.27	1.02	2.84	2.21	1.10	2.69	2.15	1.11	2.52	2.07	0.80
18.0	25.0	3.69	2.66	0.69	3.41	2.54	0.86	3.12	2.42	1.02	2.98	2.36	1.10	2.83	2.30	1.11	2.66	2.23	0.80
19.4	26.7	3.79	2.67	0.70	3.51	2.55	0.86	3.22	2.44	1.02	3.08	2.38	1.11	2.93	2.33	1.11	2.76	2.26	0.80
22.0	30.0	3.98	2.71	0.78	3.69	2.60	0.87	3.40	2.50	1.03	3.26	2.45	1.11	3.12	2.40	1.11	2.95	2.34	0.80
24.0	32.0	4.12	2.64	0.79	3.83	2.54	0.87	3.55	2.45	1.03	3.40	2.40	1.12	3.26	2.36	1.11	3.09	2.31	0.80

Temp: Fahrenheit / TC, SHC: kBtu/h / PI: kW

INDOOR		OUTDOOR TEMPERATURE (°FDB)																	
EWB	EDB	50			68			86			95			104			115		
		TC	SHC	PI	TC	SHC	PI	TC	SHC	PI	TC	SHC	PI	TC	SHC	PI	TC	SHC	PI
57.2	68.0	11.64	8.82	0.68	10.66	8.34	0.85	9.68	7.87	1.01	9.19	7.64	1.09	8.70	7.41	1.11	8.12	7.14	0.80
60.8	71.6	12.12	8.65	0.69	11.14	8.20	0.85	10.17	7.76	1.02	9.68	7.55	1.10	9.19	7.33	1.11	8.60	7.08	0.80
64.4	77.0	12.61	9.08	0.69	11.63	8.66	0.86	10.65	8.25	1.02	10.16	8.05	1.10	9.67	7.85	1.11	9.09	7.61	0.80
67.0	80.0	12.94	9.11	0.70	11.97	8.71	0.86	10.99	8.33	1.02	10.50	8.14	1.11	10.01	7.95	1.11	9.42	7.72	0.80
71.6	86.0	13.57	9.24	0.78	12.60	8.89	0.87	11.62	8.54	1.03	11.13	8.37	1.11	10.64	8.20	1.11	10.05	8.00	0.80
75.2	89.6	14.06	9.00	0.79	13.08	8.67	0.87	12.10	8.36	1.03	11.61	8.20	1.12	11.12	8.05	1.11	10.54	7.86	0.80

Heating (60 Hz, 115 V)

AFR	11.7
-----	------

Temp: Celsius / TC, SHC, PI: kW

INDOOR		OUTDOOR TEMPERATURE (°CWB)													
EDB	°C	-15		-10		-5		0		6		10		18	
		TC	PI	TC	PI	TC	PI	TC	PI	TC	PI	TC	PI	TC	PI
15.0	2.39	1.15	2.69	1.16	3.00	1.18	3.30	1.18	3.67	1.18	3.98	1.18	4.43	1.14	
21.1	2.24	1.18	2.55	1.18	2.85	1.18	3.15	1.18	3.52	1.18	3.80	1.18	4.27	1.14	
22.0	2.22	1.18	2.52	1.18	2.83	1.18	3.13	1.18	3.49	1.18	3.78	1.18	4.25	1.14	
24.0	2.17	1.18	2.48	1.18	2.78	1.18	3.08	1.18	3.44	1.18	3.73	1.18	4.20	1.14	
25.0	2.15	1.18	2.45	1.18	2.75	1.18	3.05	1.18	3.41	1.18	3.70	1.18	4.17	1.14	
27.0	2.10	1.18	2.40	1.18	2.71	1.18	3.00	1.18	3.36	1.18	3.65	1.18	4.12	1.14	

Temp: Fahrenheit / TC, SHC: kBtu/h / PI: kW

INDOOR		OUTDOOR TEMPERATURE (°FWB)													
EDB	°F	5		14		23		32		43		50		64	
		TC	PI	TC	PI	TC	PI	TC	PI	TC	PI	TC	PI	TC	PI
59.0	8.16	1.15	9.19	1.16	10.23	1.18	11.26	1.18	12.51	1.18	13.58	1.18	15.13	1.14	
70.0	7.65	1.18	8.69	1.18	9.72	1.18	10.76	1.18	12.00	1.18	12.98	1.18	14.57	1.14	
71.6	7.58	1.18	8.61	1.18	9.65	1.18	10.68	1.18	11.92	1.18	12.90	1.18	14.49	1.14	
75.2	7.41	1.18	8.45	1.18	9.48	1.18	10.51	1.18	11.74	1.18	12.71	1.18	14.32	1.14	
77.0	7.33	1.18	8.36	1.18	9.40	1.18	10.42	1.18	11.64	1.18	12.62	1.18	14.24	1.14	
80.6	7.16	1.18	8.20	1.18	9.23	1.18	10.25	1.18	11.46	1.18	12.44	1.18	14.07	1.14	

Symbols:

- AFR : Airflow rate (m³/min.)
- BF : Bypass factor
- EWB : Entering wet bulb temp. (°C) / (°F)
- EDB : Entering dry bulb temp. (°C) / (°F)
- TC : Total capacity (kW) / (kBtu/h)
- SHC : Sensible heat capacity (kW) / (kBtu/h)
- PI : Power input (kW)

Notes:

1. ■ shows MAX capacities and power input.
2. TC, PI and SHC must be calculated by interpolation using the figures in the above tables. (Figures out of the tables should not be used for calculation.)
3. Capacities are based on the following conditions.
Corresponding refrigerant piping length : 25 ft (7.5 m)
Level difference : 0 ft (0 m)
4. Airflow rate (AFR) and Bypass factor (BF) are tabulated above table.

FTXQ12ASBU9 + RXQ12ASBU9

Cooling (60 Hz, 115 V)

AFR	11.7
BF	0.18

Temp: Celsius / TC, SHC, PI: kW

INDOOR		OUTDOOR TEMPERATURE (°CDB)																	
EWB	EDB	10			20			30			35			40			46		
		TC	SHC	PI	TC	SHC	PI	TC	SHC	PI	TC	SHC	PI	TC	SHC	PI	TC	SHC	PI
14.0	20.0	4.16	3.02	0.72	3.81	2.84	0.89	3.46	2.67	1.06	3.28	2.58	1.15	3.02	2.46	1.11	2.90	2.40	0.80
16.0	22.0	4.33	2.96	0.72	3.98	2.79	0.90	3.63	2.63	1.07	3.46	2.55	1.15	3.17	2.42	1.11	3.07	2.38	0.80
18.0	25.0	4.50	3.08	0.73	4.15	2.93	0.90	3.81	2.78	1.07	3.63	2.70	1.16	3.32	2.57	1.11	3.25	2.54	0.80
19.4	26.7	4.62	3.09	0.73	4.28	2.94	0.91	3.93	2.80	1.08	3.75	2.73	1.16	3.42	2.60	1.11	3.37	2.58	0.80
22.0	30.0	4.85	3.12	0.83	4.50	2.98	0.91	4.15	2.85	1.08	3.98	2.79	1.17	3.62	2.66	1.11	3.59	2.65	0.80
24.0	32.0	5.02	3.03	0.83	4.67	2.91	0.92	4.32	2.79	1.09	4.15	2.73	1.18	3.77	2.61	1.11	3.76	2.61	0.80

Temp: Fahrenheit / TC, SHC: kBtu/h / PI: kW

INDOOR		OUTDOOR TEMPERATURE (°FDB)																	
EWB	EDB	50			68			86			95			104			115		
		TC	SHC	PI	TC	SHC	PI	TC	SHC	PI	TC	SHC	PI	TC	SHC	PI	TC	SHC	PI
57.2	68.0	14.19	10.31	0.72	13.00	9.70	0.89	11.80	9.11	1.06	11.21	8.82	1.15	10.29	8.38	1.11	9.90	8.19	0.80
60.8	71.6	14.78	10.10	0.72	13.59	9.53	0.90	12.39	8.98	1.07	11.80	8.71	1.15	10.81	8.26	1.11	10.49	8.12	0.80
64.4	77.0	15.37	10.52	0.73	14.18	10.00	0.90	12.98	9.48	1.07	12.39	9.23	1.16	11.33	8.78	1.11	11.08	8.68	0.80
67.0	80.0	15.78	10.54	0.73	14.59	10.04	0.91	13.40	9.55	1.08	12.80	9.31	1.16	11.68	8.86	1.11	11.49	8.79	0.80
71.6	86.0	16.55	10.63	0.83	15.35	10.18	0.91	14.16	9.74	1.08	13.57	9.52	1.17	12.34	9.09	1.11	12.26	9.06	0.80
75.2	89.6	17.14	10.33	0.83	15.94	9.91	0.92	14.75	9.51	1.09	14.16	9.32	1.18	12.85	8.89	1.11	12.85	8.89	0.80

Heating (60 Hz, 115 V)

AFR	12.3
-----	------

Temp: Celsius / TC, SHC, PI: kW

INDOOR		OUTDOOR TEMPERATURE (°CWB)													
EDB	°C	-15		-10		-5		0		6		10		18	
		TC	PI	TC	PI	TC	PI	TC	PI	TC	PI	TC	PI	TC	PI
15.0	2.91	1.26	3.28	1.27	3.65	1.30	4.02	1.30	4.46	1.30	4.84	1.30	5.32	1.26	
21.1	2.73	1.30	3.10	1.30	3.47	1.30	3.84	1.30	4.28	1.30	4.61	1.30	5.10	1.26	
22.0	2.70	1.30	3.07	1.30	3.44	1.30	3.81	1.30	4.25	1.30	4.57	1.30	5.07	1.26	
24.0	2.64	1.30	3.01	1.30	3.37	1.30	3.74	1.30	4.18	1.30	4.50	1.30	5.00	1.26	
25.0	2.61	1.30	2.97	1.30	3.34	1.30	3.70	1.30	4.14	1.30	4.46	1.30	4.97	1.26	
27.0	2.55	1.30	2.91	1.30	3.27	1.30	3.64	1.30	4.07	1.30	4.39	1.30	4.90	1.26	

Temp: Fahrenheit / TC, SHC: kBtu/h / PI: kW

INDOOR		OUTDOOR TEMPERATURE (°FWB)													
EDB	°F	5		14		23		32		43		50		64	
		TC	PI	TC	PI	TC	PI	TC	PI	TC	PI	TC	PI	TC	PI
59.0	9.91	1.26	11.18	1.27	12.44	1.30	13.70	1.30	15.21	1.30	16.53	1.30	18.16	1.26	
70.0	9.30	1.30	10.56	1.30	11.82	1.30	13.09	1.30	14.60	1.30	15.72	1.30	17.40	1.26	
71.6	9.21	1.30	10.47	1.30	11.73	1.30	13.00	1.30	14.51	1.30	15.60	1.30	17.29	1.26	
75.2	9.00	1.30	10.25	1.30	11.50	1.30	12.76	1.30	14.26	1.30	15.35	1.30	17.06	1.26	
77.0	8.90	1.30	10.15	1.30	11.39	1.30	12.64	1.30	14.13	1.30	15.23	1.30	16.94	1.26	
80.6	8.70	1.30	9.94	1.30	11.17	1.30	12.41	1.30	13.89	1.30	14.98	1.30	16.71	1.26	

Symbols:

- AFR : Airflow rate (m³/min.)
- BF : Bypass factor
- EWB : Entering wet bulb temp. (°C) / (°F)
- EDB : Entering dry bulb temp. (°C) / (°F)
- TC : Total capacity (kW) / (kBtu/h)
- SHC : Sensible heat capacity (kW) / (kBtu/h)
- PI : Power input (kW)

Notes:

1. ■ shows MAX capacities and power input.
2. TC, PI and SHC must be calculated by interpolation using the figures in the above tables. (Figures out of the tables should not be used for calculation.)
3. Capacities are based on the following conditions.
Corresponding refrigerant piping length : 25 ft (7.5 m)
Level difference : 0 ft (0 m)
4. Airflow rate (AFR) and Bypass factor (BF) are tabulated above table.

7.1 Capacity Correction Factor by the Length of Refrigerant Piping (Reference)

The cooling capacity and the heating capacity of the unit have to be corrected in accordance with the length of refrigerant piping — the distance between the indoor unit and the outdoor unit.

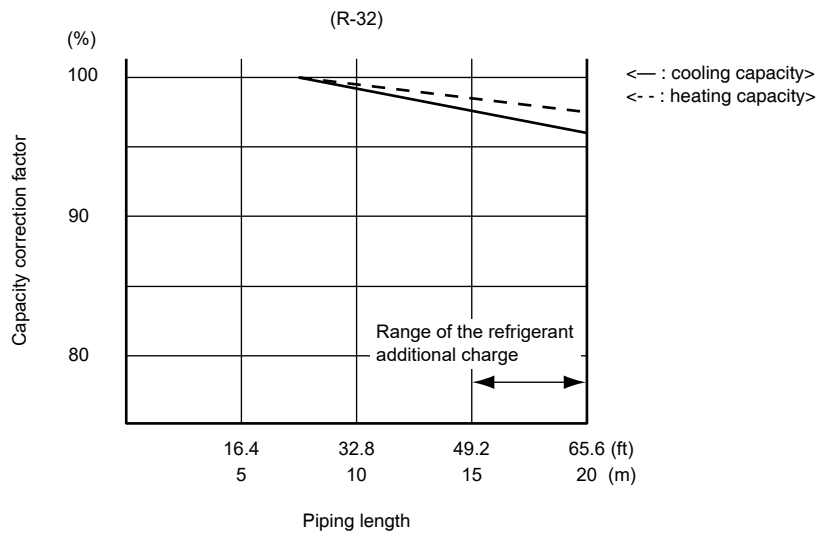

Note: The graph shows the factor when additional refrigerant of the proper quantity is charged.

8. Operation Limit

RXQ09/12ASBU9

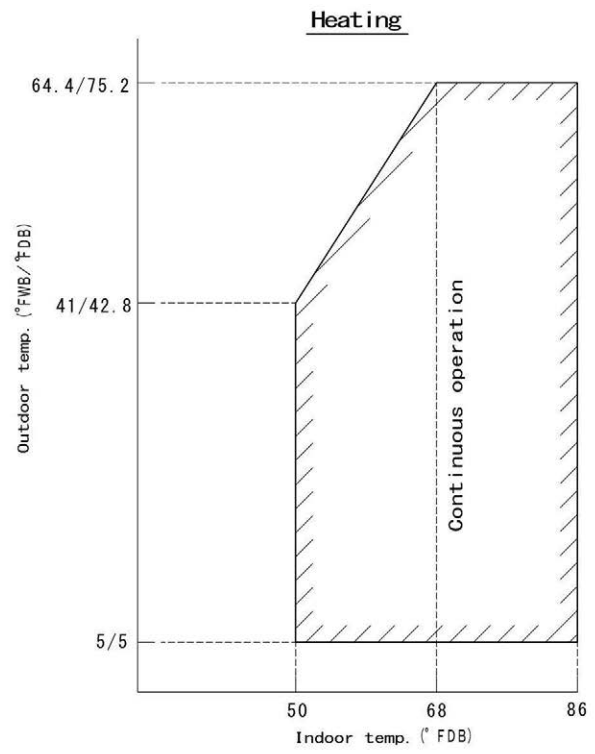
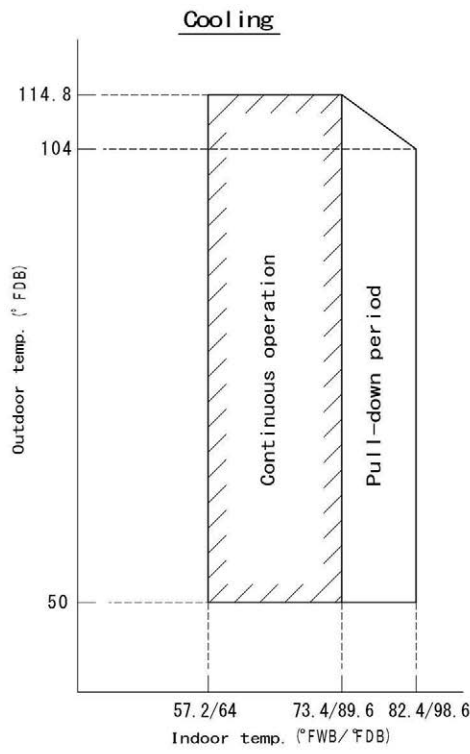

- Notes:
 The graphs are based on the following conditions.
- Equivalent piping length 25ft (7.5 m)
 - Level difference 0ft (0 m)
 - Air flow rate High

C: 3D154240

9. Sound Level

9.1 Measuring Location

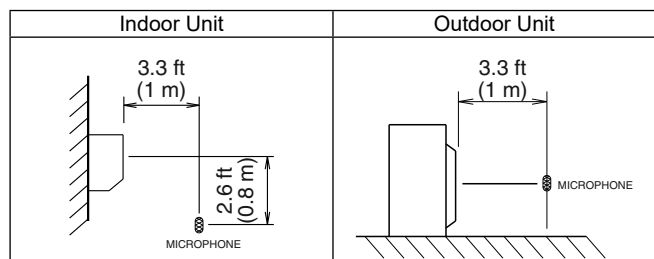

- Notes:**
1. Operation sound is measured in an anechoic chamber.
 2. The data are based on the conditions shown in the table below.

Cooling	Heating	Piping Length
Indoor ; 80.0°FDB (26.7°CDB) / 67.0°FWB (19.4°CWB) Outdoor ; 95.0°FDB (35.0°CDB) / 75.0°FWB (23.9°CWB)	Indoor ; 70.0°FDB (21.1°CDB) / 60.0°FWB (15.6°CWB) Outdoor ; 47.0°FDB (8.33°CDB) / 43.0°FWB (6.11°CWB)	25 ft (7.5 m)

9.2 Indoor Unit FTXQ09ASBU9

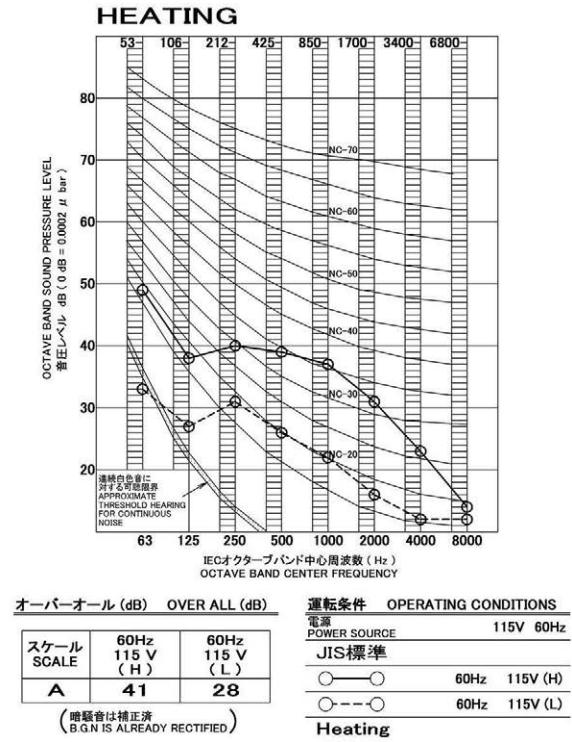
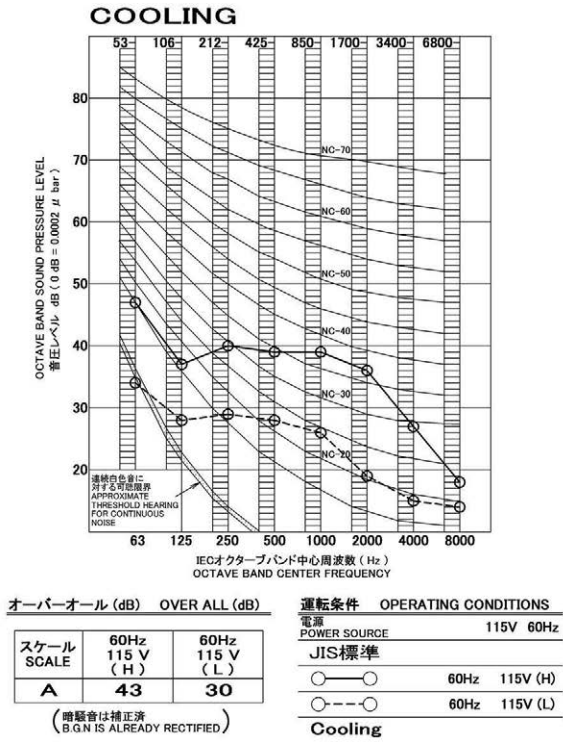

3D154238

FTXQ12ASBU9

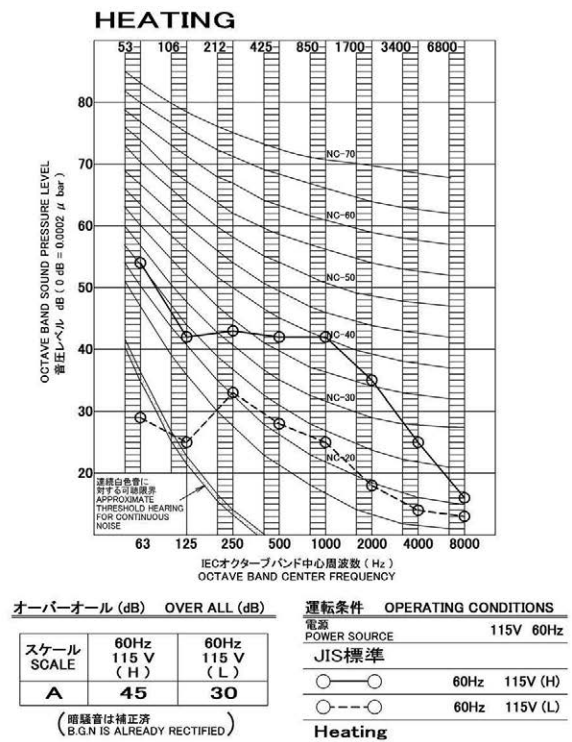
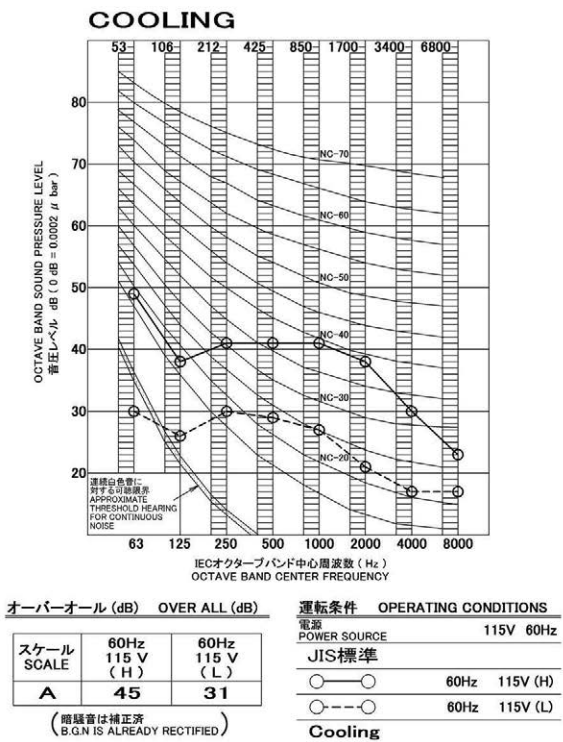

3D154239

9.3 Outdoor Unit RXQ09ASBU9

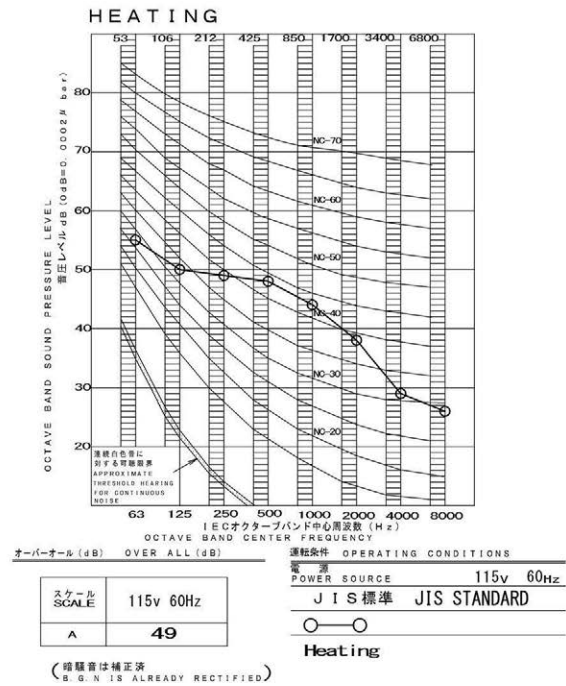
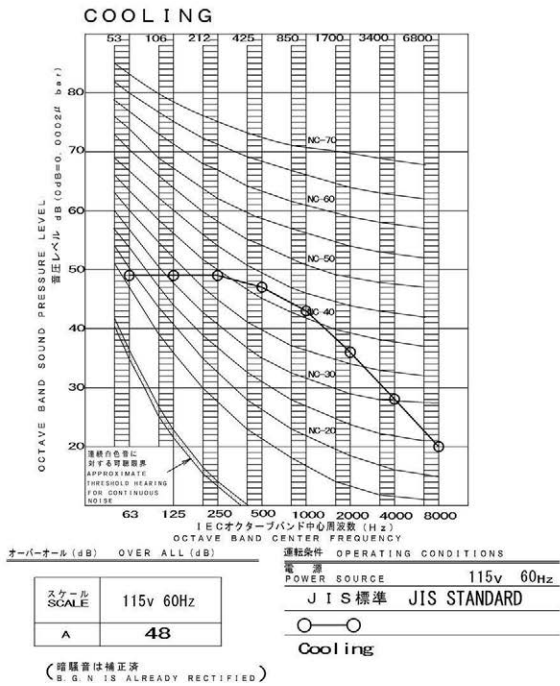

3D154241A

RXQ12ASBU9

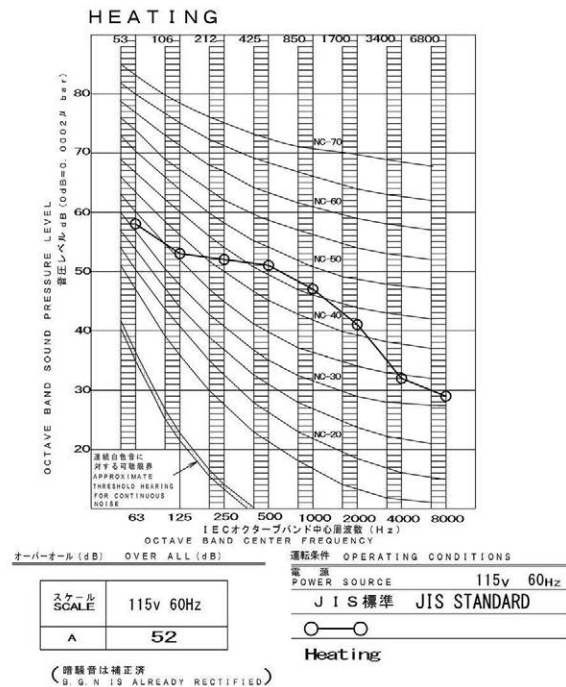
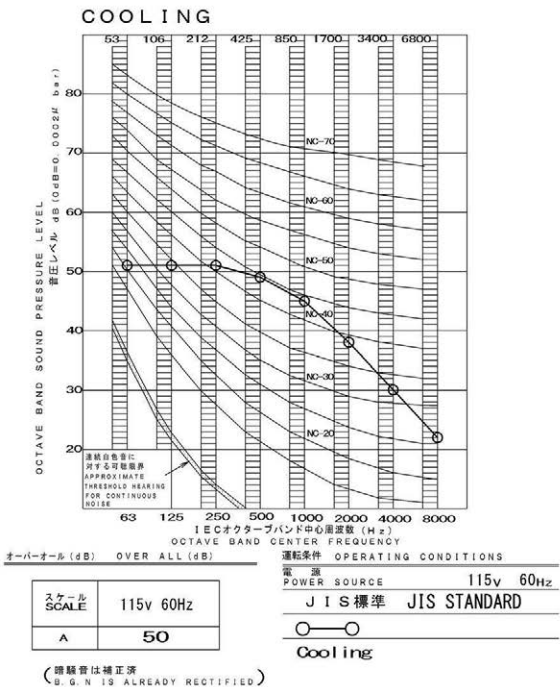

3D154242A

10. Electric Characteristics

Indoor Unit	Outdoor Unit	Power Supply				Inverter Drive Input		
		Hz - Volts	Voltage Range	MCA	MOP	System	Outdoor Fan/Compressor	Indoor Fan
FTXQ09ASBU9	RXQ09ASBU9	60 Hz - 115 V	Max. 60 Hz, 127 V Min. 60 Hz, 104 V	14.9	15	11.7	11.3	0.36
FTXQ12ASBU9	RXQ12ASBU9	60 Hz - 115 V	Max. 60 Hz, 127 V Min. 60 Hz, 104 V	15.0	15	11.7	11.3	0.42

Symbols:

MCA : Min. circuit ampacity

MOP : Max. overcurrent protective device

Notes:

1. Inverter drive input is the current value specified in annex 101. DVA.
2. Maximum allowable voltage variation between phases is 2%.
3. Select wire size based on the larger value of MCA.

3D153784

11. Installation Manual

11.1 Indoor Unit

Contents

Safety Considerations	1	Installation Tips	12
Accessories	3	1. Removing and installing the front panel	12
Choosing an Installation Site	3	2. Removing and installing the front grille.....	12
1. Indoor unit	3	3. How to set the different addresses	13
2. Wireless remote controller.....	3	4. Pump down operation.....	13
Indoor Unit Installation Diagram	4	Trial Operation and Testing	14
Indoor Unit Installation	5	1. Trial operation and testing	14
1. Installing the mounting plate.....	5	2. Test items	14
2. Drilling a wall hole and installing wall embedded pipe ...	5		
3. Installing the indoor unit	6		
4. Wiring	8		
5. Drain piping	9		
Refrigerant Piping Work	10		
1. Flaring the pipe end *	10		
2. Refrigerant piping *	10		

Product information, manuals, etc., are available from the link below.

Web site: <https://daikinac.com/>



The pictures in this document are for illustrative purposes only.

* When performing work using the flareless joints (included with outdoor unit), refer to the instruction manual for flareless joints.

Safety Considerations

Refer also to the General Safety Considerations in the separate booklet.

	Read the precautions in this manual carefully before operating the unit.
	This appliance is filled with R32.

Read these **Safety Considerations for Installation** carefully before installing an air conditioner or heat pump. After completing the installation, make sure that the unit operates properly during the startup operation. Instruct the user on how to operate and maintain the unit. Inform users that they should store this installation manual with the operation manual for future reference. Always use a licensed installer or contractor to install this product. Improper installation can result in water or refrigerant leakage, electric shock, fire, or explosion. Meanings of **DANGER**, **WARNING**, **CAUTION**, and **NOTE** Symbols:

- DANGER** Indicates an imminently hazardous situation which, if not avoided, will result in death or serious injury.
- WARNING** Indicates a potentially hazardous situation which, if not avoided, could result in death or serious injury.
- CAUTION** Indicates a potentially hazardous situation which, if not avoided, may result in minor or moderate injury. It may also be used to alert against unsafe practices.
- NOTE** Indicates situations that may result in equipment or property-damage accidents only.

DANGER

- Refrigerant gas is heavier than air and replaces oxygen. A massive leak can lead to oxygen depletion, especially in basements, and an asphyxiation hazard could occur leading to serious injury or death.
- Do not ground units to water pipes, gas pipes, telephone wires, or lightning rods as incomplete grounding can cause a severe shock hazard resulting in severe injury or death. Additionally, grounding to gas pipes could cause a gas leak and potential explosion causing severe injury or death.
- If refrigerant gas leaks during installation, ventilate the area immediately. Refrigerant gas may produce toxic gas if it comes into contact with fire. Exposure to this gas could cause severe injury or death.
- After completing the installation work, check that the refrigerant gas does not leak throughout the system.
- Do not install unit in an area where flammable materials are present due to risk of explosions that can cause serious injury or death.
- Safely dispose all packing and transportation materials in accordance with federal/state/local laws or ordinances. Packing materials such as nails and other metal or wood parts, including plastic packing materials used for transportation may cause injury or death by suffocation.
- All possible ignition sources, including cigarette smoking, should be kept sufficiently far away from the site of installation, repairing, removing and disposal.

WARNING

- Only qualified personnel licensed or certified in their jurisdiction must carry out the installation work. Installation must be done in accordance with this installation manual. Improper installation may result in water leakage, electric shock, or fire.
- Pipe-work including piping material, pipe routing, and installation shall include protection from physical damage in operation and service, and be in compliance with national and local codes and standards, such as ASHRAE 15, ASHRAE 15.2, IAPMO Uniform Mechanical Code, ICC International Mechanical Code, or CSA B52. All field joints shall be accessible for inspection prior to being covered or enclosed.

- When installing the unit in a small room, take measures to keep the refrigerant concentration from exceeding allowable safety limits. Excessive refrigerant leaks, in the event of an accident in a closed ambient space, can lead to oxygen deficiency.
- Use only specified accessories and parts for installation work. Failure to use specified parts may result in water leakage, electric shock, fire, or the unit falling.
- Install the air conditioner or heat pump on a foundation strong enough that it can withstand the weight of the unit. A foundation of insufficient strength may result in the unit falling and causing injury.
- Take into account strong winds, typhoons, or earthquakes when installing. Improper installation may result in the unit falling and causing accidents.
- The unit must have an uninterrupted, unbroken electrical ground to minimize the possibility of personal injury if an electrical fault should occur.
The electrical ground circuit may consist of an appropriately sized electrical wire connecting the ground lug in the unit and control box wire to the building's electrical service panel. Other methods of grounding are permitted if performed in accordance with the "National Electrical Code" (NEC)/ "American National Standards Institute" (ANSI)/ "National Fire Protection Association" (NFPA) 70 and local/state codes.
In CANADA, electrical grounding is to be in accordance with the Canadian Electrical Code CSA C22.1.
Failure to observe this warning can result in electrical shock that can cause personal injury or death.
- Make sure that a separate power supply circuit is provided for this unit and that all electrical work is carried out by qualified personnel licensed or certified in their jurisdiction according to local, state, and national regulations. An insufficient power supply capacity or improper electrical construction may lead to electric shock or fire.
- Make sure that all wiring is secured, that specified wires are used, and that no external forces act on the terminal connections or wires. Improper connections or installation may result in fire.
- When wiring, position the wires so that the service lid can be securely fastened. Improper positioning of the service lid may result in electric shock, fire, or the terminals overheating.
- Before touching electrical parts, turn off the unit.
- The circuit must be protected with safety devices in accordance with local and national codes, i.e. a circuit breaker.
- Securely fasten the outdoor unit service lid. If the service lid is not installed properly, dust or water may enter the outdoor unit causing fire or electric shock.
- When installing or relocating the system, keep the refrigerant circuit free from substances other than the specified refrigerant (R32) such as air. Any presence of air or other foreign substance in the refrigerant circuit can cause an abnormal pressure rise or rupture, which may result in equipment damage and even injury.
- Do not change the setting of the protection devices. If the pressure switch, thermal switch, or other protection device is shorted and operated forcibly, or parts other than those specified by Daikin are used, fire or explosion may occur.
- Do not use means to accelerate the defrosting process (if possible) or to clean, other than those recommended by the manufacturer.
- The appliance must be stored in a room without continuously operating ignition sources (for example: open flames, an operating gas appliance or an operating electric heater).
- Do not pierce or burn.
- Be aware that refrigerants may not contain an odor.
- Comply with national gas regulations.
- The indoor equipment and pipes shall be securely mounted and guarded such that accidental rupture of equipment cannot occur from such events as moving furniture or reconstruction activities.

CAUTION

- Do not touch the switch with wet fingers. Touching a switch with wet fingers can cause electric shock.
- Do not allow children to play on or around the unit to prevent injury.
- Wear adequate personal protective equipment (protective gloves, safety glasses,...) when installing, maintaining or servicing the system.
- The heat exchanger fins are sharp enough to cut. To avoid injury, wear gloves or cover the fins while working around them.
- Do not touch the refrigerant pipes during and immediately after operation as the refrigerant pipes may be hot or cold, depending on the condition of the refrigerant flowing through the refrigerant piping, compressor, and other refrigerant cycle parts. Your hands may suffer burns or frostbite if you touch the refrigerant pipes. To avoid injury, give the pipes time to return to normal temperature or, if you must touch them, be sure to wear proper gloves.
- Install drain piping to ensure proper drainage. Improper drain piping may result in water leakage and property damage.
- Insulate piping to prevent condensation.
- Be careful when transporting the product.
- Do not turn off the power immediately after stopping operation. Always wait for at least 5 minutes before turning off the power. Otherwise, water leakage may occur.
- Do not use a charging cylinder. Using a charging cylinder may cause the refrigerant to deteriorate.
- Refrigerant R32 in the system must be kept clean, dry, and tight.
 - (a) Clean and Dry -- Foreign materials (including mineral oils such as SUNISO oil or moisture) should be prevented from getting into the system.
 - (b) Tight -- R32 does not contain any chlorine, does not destroy the ozone layer, and does not reduce the earth's protection against harmful ultraviolet radiation. R32 can contribute to the greenhouse effect if it is released. Therefore take proper measures to check for the tightness of the refrigerant piping installation. Read the chapter *Refrigerant Piping Work* and follow the procedures.
- The indoor unit is for R32. See the catalog for outdoor models that can be connected. Normal operation is not possible when connected to non-compatible outdoor units.
- Remote controller (wireless kit) transmitting distance can be shorter than expected in rooms with electronic fluorescent lamps (inverter or rapid start types). Install the indoor unit far away from fluorescent lamps as much as possible.
- Indoor units are for indoor installation only. Outdoor units can be installed either outdoors or indoors.
- Do not install the air conditioner or heat pump in the following locations:
 - (a) Where a mineral oil mist or oil spray or vapor is produced, for example, in a kitchen. Plastic parts may deteriorate and fall off or result in water leakage.
 - (b) Where corrosive gas, such as sulfurous acid gas, is produced. Corroding copper pipes or soldered parts may result in refrigerant leakage.
 - (c) Near machinery emitting electromagnetic waves. Electromagnetic waves may disturb the operation of the control system and cause the unit to malfunction.
 - (d) Where flammable gas may leak, where there is carbon fiber, or ignitable dust suspension in the air, or where volatile flammables such as thinner or gasoline are handled. Operating the unit in such conditions can cause a fire.
- Take adequate measures to prevent the outdoor unit from being used as a shelter by small animals. Small animals making contact with electrical parts can cause malfunctions, smoke, or fire. Instruct the user to keep the area around the unit clean.
- Servicing shall be performed only as recommended by the manufacturer and licensed or certified in their jurisdiction.











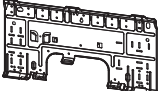

Safety Considerations

NOTE

- The indoor unit should be positioned where the unit and interunit wires (outdoor to indoor) are at least 3.3ft (1m) away from any televisions or radios. (The unit may cause interference with the picture or sound.) Depending on the radio waves, a distance of 3.3ft (1m) may not be sufficient to eliminate the noise.
- Dismantling the unit, treatment of the refrigerant, oil and additional parts must be done in accordance with the relevant local, state, and national regulations.
- Only use tools for R32, such as a gauge manifold, charge hose, gas leak detector, reverse flow check valve, refrigerant charge base, vacuum gauge, or refrigerant recovery equipment.
- If the conventional refrigerant and refrigerator oil are mixed in R32, the refrigerant may deteriorate.
- As maximum allowable pressure is 604psi (4.17MPa), the wall thickness of field-installed pipes should be selected in accordance with the relevant local, state, and national regulations.

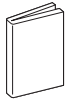
FTN007(R32)-U

Accessories

<p>(A) Mounting plate</p> 	1	<p>(B) Mounting plate fixing screw M4 × 1" (M4 × 25mm)</p> 	7	<p>(C) Wireless remote controller</p> 	1
<p>(D) Remote controller holder</p> 	1	<p>(E) Remote controller holder fixing screw M3 × 13/16" (M3 × 20mm)</p> 	2	<p>(F) Dry battery AAA. LR03 (alkaline)</p> 	2
<p>(G) Indoor unit fixing screw M4 × 1/2" (M4 × 12mm)</p> 	2	<p>(H) Insulation tape</p> 	1	<p>(J) Operation manual</p> 	1
<p>(K) Installation manual</p> 	1	<p>(L) Warranty</p> 	1	<p>(M) General safety considerations</p> 	1

Choosing an Installation Site

- Before choosing the installation site, obtain user approval.

1. Indoor unit

- The indoor unit should be positioned in a place where:
 - 1) the restrictions on the installation requirements specified in "Indoor Unit Installation Diagram" on page 4 are met,
 - 2) both the air inlet and air outlet are unobstructed,
 - 3) the unit is not exposed to direct sunlight,
 - 4) drainage occurs easily,
 - 5) the unit is away from sources of heat or steam,
 - 6) there is no source of machine oil vapor (this may shorten the indoor unit service life),
 - 7) cool/warm air is circulated throughout the room,
 - 8) the unit is away from electronic ignition type fluorescent lamps (inverter or rapid start type) as they may affect the remote controller range,
 - 9) the unit is at least 3.3ft (1m) away from any television or radio set (the unit may cause interference with the picture or sound),
 - 10) no laundry equipment is nearby,
 - 11) the signal strength of the router is stable (insufficient signal strength can prevent stable communication).

2. Wireless remote controller

- Turn on all the fluorescent lamps in the room, if any, and find a location where the remote controller signals are properly received by the indoor unit (within 23ft (7m)).

Indoor Unit Installation Diagram

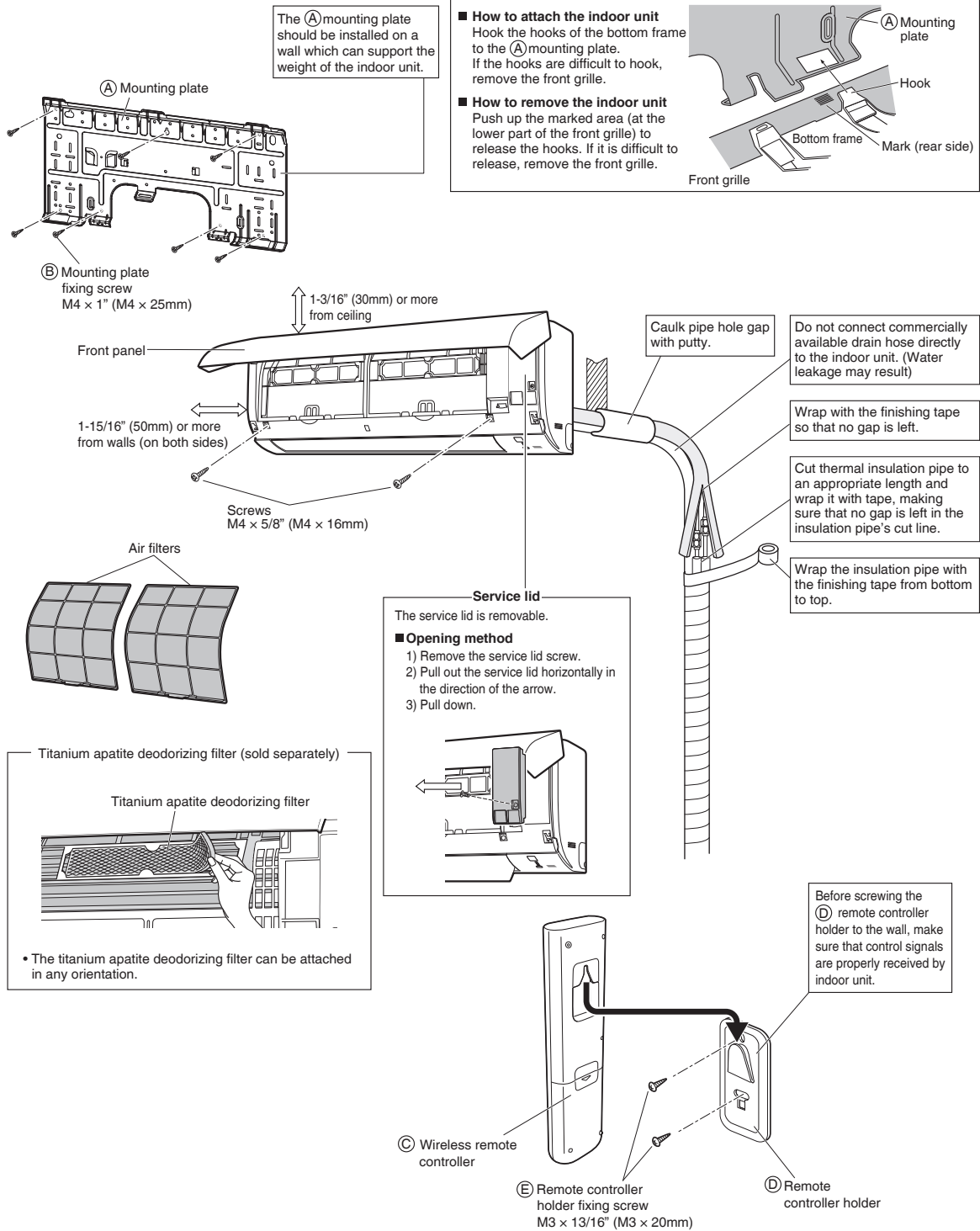

Indoor Unit Installation

1. Installing the mounting plate

- The mounting plate should be installed on a wall which can support the weight of the indoor unit.
 - Temporarily secure the mounting plate to the wall, make sure that the panel is completely level, and mark the drilling points on the wall.
 - Secure the mounting plate to the wall with screws.

Recommended mounting plate retention spots and dimensions

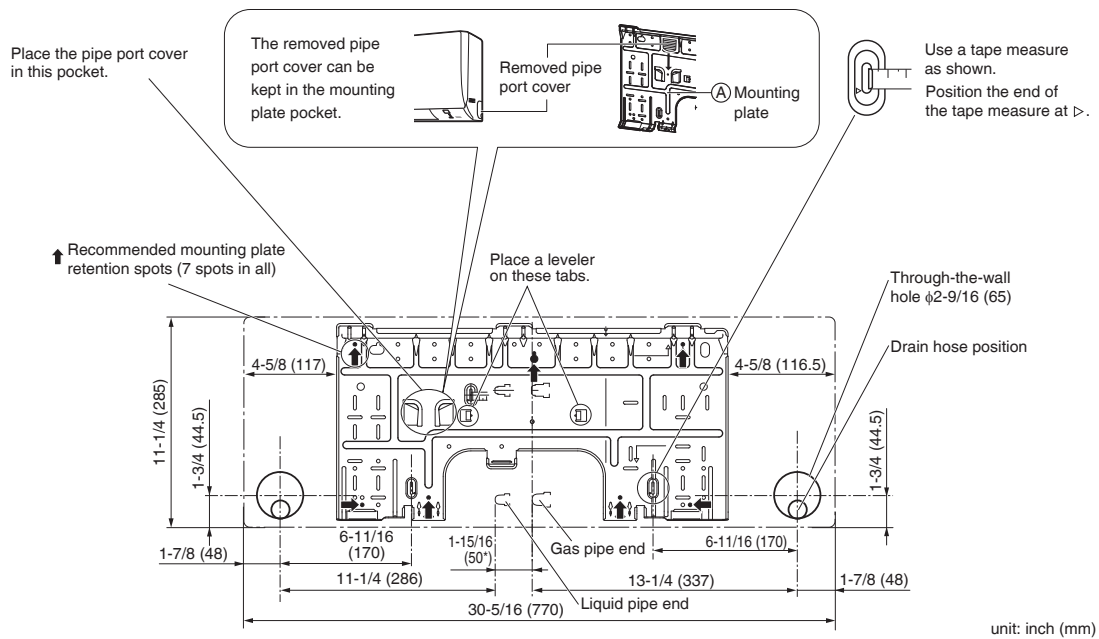

* Depending on the model, the actual distance between the liquid pipe end and gas pipe end may differ from the distance between those symbols on the mounting plate (the distance listed in this manual). Always measure the actual distance between the liquid pipe end and gas pipe end before installing refrigerant pipes.

2. Drilling a wall hole and installing wall embedded pipe

⚠ WARNING

For metal frame or metal board walls, be sure to use a wall embedded pipe and wall hole cover in the feed-through hole to prevent possible heat, electric shock, or fire.

- Be sure to caulk the gaps around the pipes with caulking material to prevent condensation.
 - Drill a feed-through hole with a $\phi 2-9/16$ inch (65mm) diameter through the wall at a downward angle toward the outside.
 - Insert a wall embedded pipe into the hole.
 - Insert a wall hole cover into wall pipe.
 - After completing refrigerant piping, wiring, and drain piping, caulk the pipe hole gap with putty.

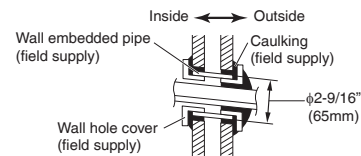

Even if a wall hole cover is not used, caulk both the outdoor and indoor sides with putty.

3. Installing the indoor unit

In the case of bending or curing refrigerant pipes, keep the following precautions in mind. Abnormal sound may be generated if improper work is conducted.

- Do not strongly press the refrigerant pipes onto the bottom frame.
- Do not strongly press the refrigerant pipes on the front grille, either.

3-1. Right-side, right-back, or right-bottom piping

- 1) Attach the drain hose to the underside of the refrigerant pipes with adhesive vinyl tape.
- 2) Wrap the refrigerant pipes and drain hose together with \oplus insulation tape.

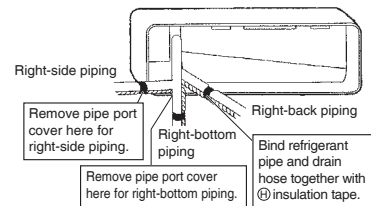

- 3) Pass the drain hose and refrigerant pipes through the wall hole, then position the indoor unit on the $\text{\textcircled{A}}$ mounting plate hooks by using the \triangle markings at the top of the indoor unit as a guide.

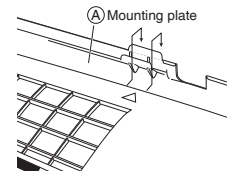

- 4) Open the front panel (Refer to "Installation Tips" on page 12), then open the service lid (Refer to "Indoor Unit Installation Diagram" on page 4).
- 5) Pass the inter-unit wire from the outdoor unit through the feed-through wall hole and pass to the front of indoor unit from the back. Then pull them at front side. Bend the ends of cable tie wires upward for easier work in advance. (If the interunit wire ends are to be stripped first, bundle wire ends with adhesive tape.)
- 6) Press the bottom frame of the indoor unit with both hands until it is firmly caught by the $\text{\textcircled{A}}$ mounting plate hooks. Make sure the wire leads do not catch on the edge of the indoor unit.

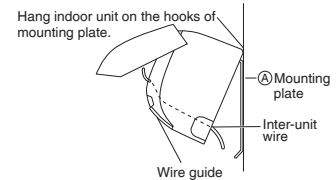

3-2. Left-side, left-back, or left-bottom piping

- 1) Switch around the drain plug and drain hose.

How to switch around the drain plug and drain hose

1) Remove the fixing screw and pull out the drain hose.

3) Switch around the drain hose and drain plug.

Push the drain plug all the way in using a hexagonal wrench (3/16 inch (4mm)).

Do not apply lubricating oil (refrigerant oil) to the drain plug when inserting it. The application of lubrication oil to the drain plug will deteriorate the plug to cause drain leakage from the plug.

Insert drain hose securely and fix in place with fixing screw.

Indoor Unit Installation

2) Attach the drain hose to the underside of the refrigerant pipes with adhesive vinyl tape.

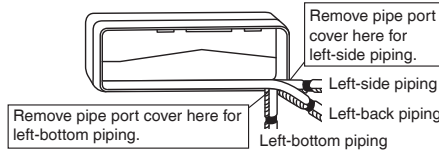

3) Shape the refrigerant pipes along the pipe path marking on the (A) mounting plate.

4) Pass the drain hose and refrigerant pipes through the wall hole, then position the indoor unit on the (A) mounting plate hooks, using the Δ markings at the top of the indoor unit as a guide.

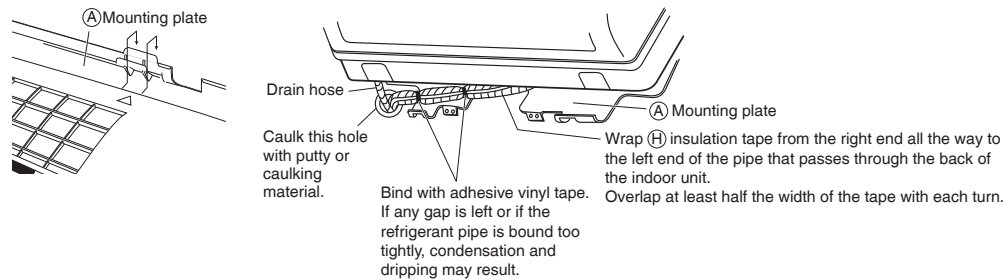

5) Open the front panel (Refer to "Installation Tips" on page 12), then open the service lid (Refer to "Indoor Unit Installation Diagram" on page 4).

6) Pass the inter-unit wire from the outdoor unit through the feed-through wall hole and pass to the front of indoor unit from the back. Then pull them at front side. Bend the ends of cable tie wires upward for easier work in advance. (If the interunit wire ends are to be stripped first, bundle wire ends with adhesive tape.)

7) Connect the refrigerant pipes.

8) In case of pulling the drain hose through the back of the indoor unit, wrap the refrigerant pipes and drain hose together with (H) insulation tape as shown in the figure below.

9) Press the bottom frame of the indoor unit with both hands until it is firmly caught by the (A) mounting plate hooks. Make sure that the wires do not catch on the edge of the indoor unit.

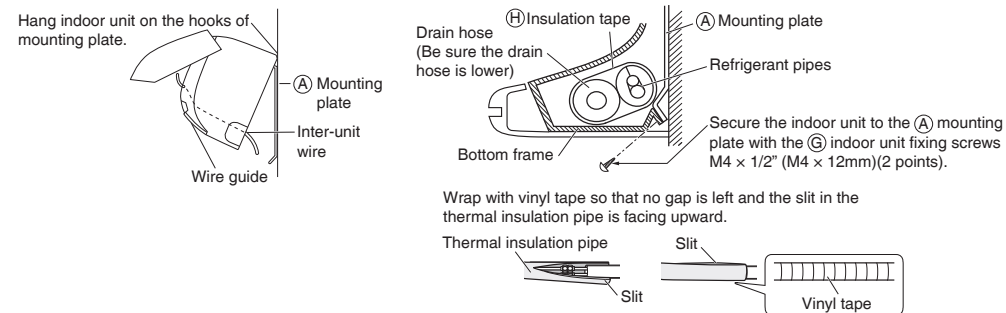

3-3. Wall embedded piping

Follow the instructions given under left-side, left-back, or left-bottom piping.

1) Insert the drain hose to a depth of 1-15/16 inches (50mm) or more so it will not be pulled out of the drain pipe.

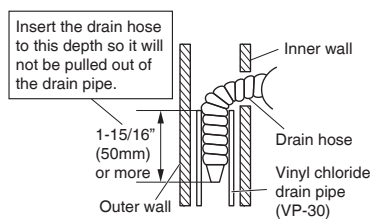

4. Wiring

Refer to the installation manual for the outdoor unit also.

⚠ WARNING

- Do not use tapped wires, extension cords, or starburst connections, as they may cause overheating, electric shock, or fire.
- Do not use locally purchased electrical parts inside the product. (Do not branch the power for the drain pump, etc., from the terminal block.) Doing so may cause electric shock or fire.
- Do not connect the power wire to the indoor unit. Doing so may cause electric shock or fire.

⚠ CAUTION

Recommend stranded cable for interunit wiring. Local code always supersedes recommendation.

- For stranded wires, make sure to use the round crimp-style terminal for connection to the power supply terminal block. Place the round crimp-style terminals on the wires up to the covered part and secure in place.

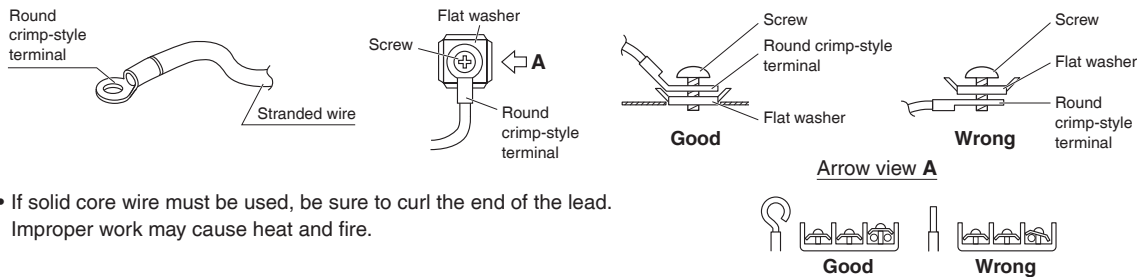

- If solid core wire must be used, be sure to curl the end of the lead. Improper work may cause heat and fire.

- 1) Remove the front grille. (Refer to “2. Removing and installing the front grille” on page 12.)
- 2) Remove the conduit mounting plate and then secure the conduit to the conduit mounting plate with the lock nut, as shown in the illustration.
- 3) Strip wire ends (3/4 inch (20mm)).
- 4) Match wire colors with terminal numbers on the indoor and outdoor unit’s terminal blocks and firmly secure the wires in the corresponding terminals with the screws.
- 5) Connect the ground wires to the corresponding terminals.
- 6) Pull the wires lightly to make sure they are securely connected.
- 7) Attach the conduit mounting plate.
- 8) Shape the wires so that the service lid fits securely.
- 9) Attach the front grille. (Refer to “2. Removing and installing the front grille” on page 12.)
- 10) Take care to ensure that all wiring between the indoor unit and the outdoor unit has a consistent connection. Any splices can cause communication errors.

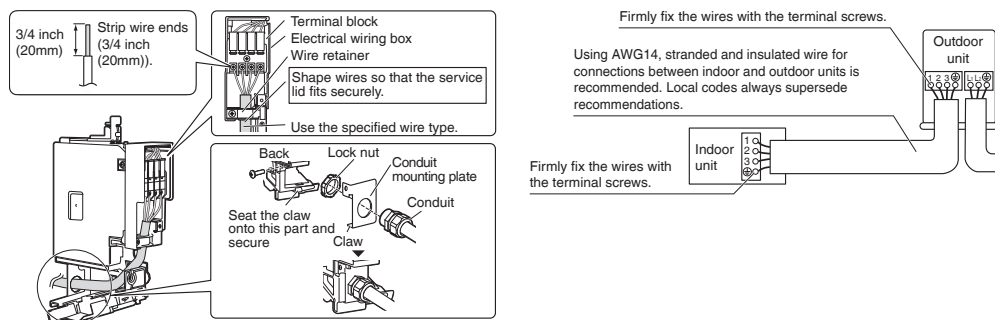

Indoor Unit Installation

5. Drain piping

- 1) Connect the drain hose, as shown below.
 - Avoid placing the end of the drain hose in a drainage location that could cause bad odors or corrosive gas to flow backward into the outlet.
 - The drainage water may change color due to bacteria or other organisms. Place in a location where the flow of drainage water will not cause a problem.
 - Minimize the number of bends in the drain hose as much as possible. If bending the drain hose, bend it gently.

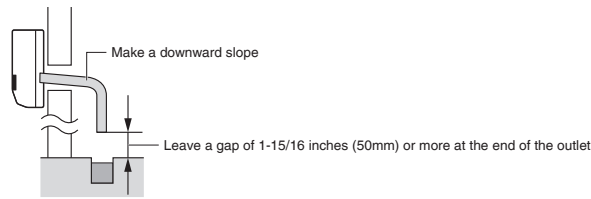

Getting higher

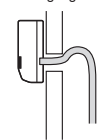

Wrong

Containing waves

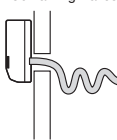

Wrong

With the end of the hose in the drain outlet

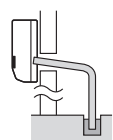

Wrong

- 2) Remove the air filters and transfer some water to the indoor heat exchanger by pouring water into the drain pan.
- 3) Make sure that water flows out of the drain hose.

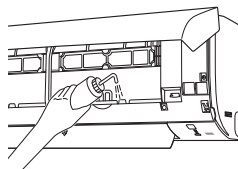

- 4) If drain hose extension or embedded drain piping is required, use appropriate parts that match the hose front end.
 - When drain hose requires extension, obtain an extension hose with an inner diameter of 5/8 inch (16mm). Be sure to thermally insulate the indoor section of the extension hose.

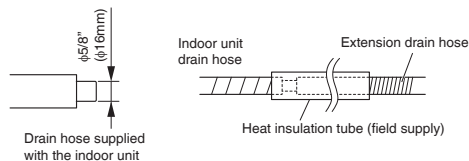

Refrigerant Piping Work

⚠ WARNING

- Do not apply mineral oil to the flare.
- Prevent mineral oil from getting into the system as this would reduce the service life of the units.
- Never use piping which has been used for previous installations. Only use parts which are delivered with this unit.
- Never install a dryer to this R32 unit in order to guarantee its service life.
- The drying material may dissolve and damage the system.
- Improper flaring may result in refrigerant gas leakage.

1. Flaring the pipe end

When performing work using the flareless joints (included with outdoor unit), refer to the instruction manual for flareless joints.

- 1) Cut the pipe end with a pipe cutter.
- 2) Remove burrs with the cut surface facing downward, so that the filings do not enter the pipe.



- 3) Put the flare nut on the pipe.
- 4) Flare the pipe.
- 5) Check that the flaring has been done correctly.

Flaring

Set exactly at the position shown below.

Flare tool for R32 or R410A	Conventional flare tool	
	Clutch-type	Wing-nut type (Imperial-type)
A	0-0.020 inch (0-0.5mm)	0.039-0.059 inch (1.0-1.5mm)

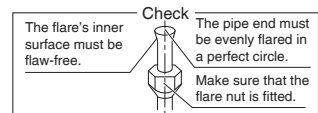

2. Refrigerant piping

When performing work using the flareless joints (included with outdoor unit), refer to the instruction manual for flareless joints.

⚠ CAUTION

- Use the flare nut fixed to the main unit. (This is to prevent the flare nut from cracking as a result of deterioration over time.)
- Use a torque wrench when tightening the flare nuts to prevent damage to the flare nuts and gas leakage.
- Excessive tightening of the flare nut can result in the flare nut cracking in the long term, leading to gas leakage.

- Align the centers of both flares and tighten the flare nuts 3 or 4 turns by hand, then tighten them fully with a spanner and a torque wrench.

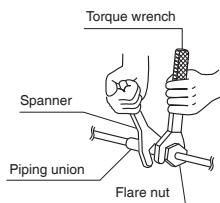
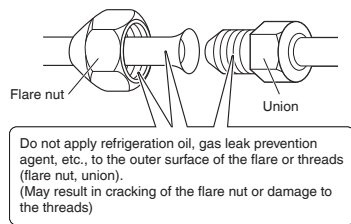

	Piping size	Flare nut tightening torque
Gas side	O.D. 3/8 inch (9.5mm)	24-1/8 – 29-1/2 lbf • ft (32.7-39.9 N • m)
Liquid side	O.D. 1/4 inch (6.4mm)	10-1/2 – 12-3/4 lbf • ft (14.2-17.2 N • m)

Caution on piping handling

- Protect the open end of the pipe against dust and moisture.
- All pipe bends should be as gentle as possible. Use a pipe bender for bending.

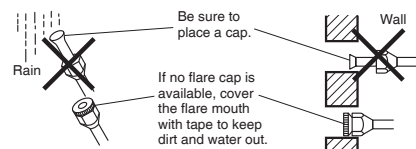

Refrigerant Piping Work

Selection of copper and heat insulation materials

When using commercial copper pipes and fittings, observe the following:

- Insulation material: Polyethylene foam
Heat transfer rate: 0.041 to 0.052W/mK (0.024 to 0.030Btu/ft^h°F (0.035 to 0.045kcal/mh°C))
Be sure to use insulation that is designed for use with HVAC Systems.
- ACR Copper only.

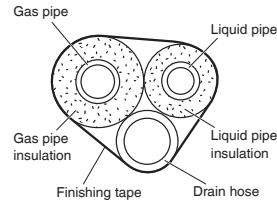

- Be sure to insulate both the gas and liquid piping and observe the insulation dimensions as below.

	Piping size	Minimum bend radius	Piping thickness	Thermal insulation size	Thermal insulation thickness
Gas side	O.D. 3/8 inch (9.5mm)	1-3/16 inch (30mm) or more	0.031 inch (0.8mm) (C1220T-O)	I.D. 15/32-19/32 inch (12-15mm)	13/32 inch (10mm) Min.
Liquid side	O.D. 1/4 inch (6.4mm)	1-3/16 inch (30mm) or more	0.031 inch (0.8mm) (C1220T-O)	I.D. 5/16-13/32 inch (8-10mm)	

- Use separate thermal insulation pipes for gas and liquid refrigerant pipes.
- Using finishing tape, bundle and wrap the indoor unit piping and drain hose together so that the drain hose is below the other piping.

Installation Tips

1. Removing and installing the front panel

• **Removal method**

1) Hold the front panel by the sides and pull it open until it stops.

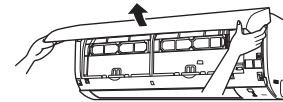

2) While pushing the left side front panel shaft outward, push up the front panel and remove it. (Remove the right side front panel shaft in the same manner.)

3) After removing both front panel shafts, pull the front panel toward yourself and remove it.

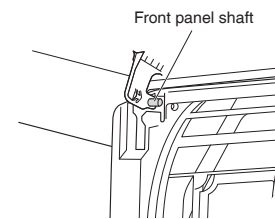

• **Installation method**

Align the front panel shaft of the front panel with the grooves of grille, and push all the way in, then close slowly. Push the center of the lower panel surface firmly to engage the tabs.

2. Removing and installing the front grille

• **Removal method**

1) Remove the front panel and air filters.
2) Remove the 2 screws from the front grille.

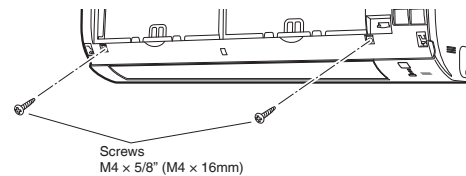

3) In front of the ○○○ mark on the front grille, there are 3 upper hooks. Lightly pull the front grille toward you with one hand, and push down on the hooks with the fingers of your other hand.

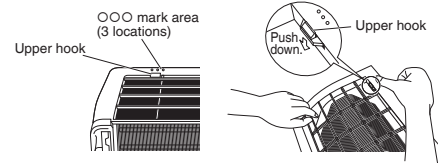

When there is insufficient work space because the unit is close to ceiling

⚠ CAUTION
Be sure to wear protection gloves.

Place both hands under the center of the front grille, and while pushing up, pull it toward you.

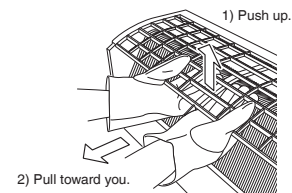

• **Installation method**

1) Install the front grille and firmly engage the upper hooks (3 locations).
2) Install 2 screws of the front grille.
3) Install the air filters and then mount the front panel.

Installation Tips

3. How to set the different addresses

When 2 indoor units are installed in one room, the 2 wireless remote controllers can be set for different addresses. Change the address setting of one of the 2 units. When cutting the jumper, be careful not to damage any of the surrounding parts.

- 1) Remove the battery cover on the remote controller and cut the address jumper.
- 2) Press , and at the same time.
- 3) Press , then select , press .
(The indoor unit OPERATION lamp will blink for about 1 minute.)
- 4) Press the indoor unit ON/OFF switch while the OPERATION lamp is blinking.

Remove the batteries before cutting the jumper.

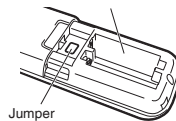

Jumper	Address	
	1	2
Jumper	EXIST	CUT

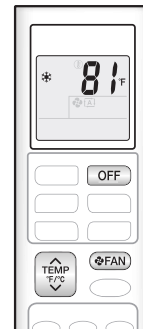

- If setting could not be carried out completely while the OPERATION lamp was blinking, carry out the setting process once again from the beginning.
- After setting is complete, pressing for about 5 seconds will cause the remote controller to return to the previous display.

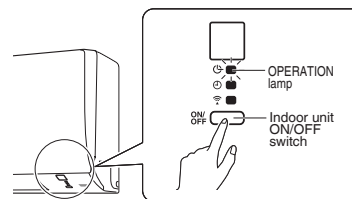

4. Pump down operation

In order to protect the environment, be sure to pump down when relocating or disposing of the unit.

For instructions on how to pump down, refer to the installation manual for the outdoor unit to be connected.

Forced cooling operation

■Using the indoor unit ON/OFF switch

Press the indoor unit ON/OFF switch for at least 5 seconds. (The operation will start.)

- Forced cooling operation will stop automatically after about 15 minutes.
To stop the operation, press the indoor unit ON/OFF switch.

■Using the indoor unit's remote controller

- 1) Press , and at the same time.
 - 2) Press , then select , press .
 - 3) Press to turn on the system.
- Forced cooling operation will stop automatically after about 30 minutes.
To stop the operation, press .

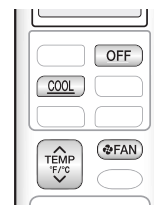

Trial Operation and Testing

1. Trial operation and testing

- Trial operation should be carried out in either COOL or HEAT operation.

1-1. Measure the supply voltage and make sure that it is within the specified range.

1-2. In COOL operation, select the lowest programmable temperature; in HEAT operation, select the highest programmable temperature.



1-3. Carry out the trial operation following the instructions in the operation manual to ensure that all functions and parts, such as the movement of the flap, are working properly.

- To protect the air conditioner, restart operation is disabled for 3 minutes after the system has been turned off.

1-4. After trial operation is complete, set the temperature to a normal level (78°F to 82°F (26°C to 28°C) in COOL operation, 68°F to 75°F (20°C to 24°C) in HEAT operation).

- When operating the air conditioner in COOL operation in winter, or HEAT operation in summer, set it to the trial operation mode using the following method.

1) Press  ,  and  at the same time.

2) Press  , then select  , press  .

3) Press  or  to turn on the system.

- Trial operation will stop automatically after about 30 minutes. To stop the operation, press  .
- Some of the functions cannot be used in the trial operation mode.

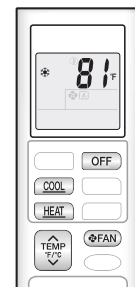

- The air conditioner draws a small amount of power in its standby mode. If the system is not to be used for some time after installation, shut off the circuit breaker to eliminate unnecessary power consumption.
- If the circuit breaker trips to shut off the power to the air conditioner, the system will restore the original operation mode when the circuit breaker is turned on again.

2. Test items

Test items	Symptom	Check
Indoor and outdoor units are installed securely.	Fall, vibration, noise	
No refrigerant gas leaks.	Incomplete cooling/heating function	
Refrigerant gas and liquid pipes and indoor drain hose extension are thermally insulated.	Water leakage	
Draining line is properly installed.	Water leakage	
System is properly grounded.	Electrical leakage	
Only specified wires are used for all wiring, and all wires are connected correctly.	No operation or burn damage	
Indoor or outdoor unit's air inlet or air outlet are unobstructed.	Incomplete cooling/heating function	
Stop valves are opened.	Incomplete cooling/heating function	
Indoor unit properly receives remote control commands.	No operation	

11.2 Outdoor Unit

Contents

Safety Considerations	1	4. Refrigerant piping	8
Accessories	3	5. Pressure test and evacuating system.....	9
Installation Space Requirements	4	Wiring	10
Precautions for Selecting a Location	4	Pump Down Operation	12
Precautions on Installation	5	Trial Operation and Testing	12
Outdoor Unit Installation Diagram	5	1. Trial operation and testing	12
Selecting a Location for Installation of the Indoor Units	6	2. Test items	12
Outdoor Unit Installation	7		
1. Installing the outdoor unit	7		
2. Drain work	7		
3. Flaring the pipe end.....	7		

Product information, manuals, etc., are available from the link below.

Web site: <https://daikinac.com/>



The pictures in this document are for illustrative purposes only.

*1 The drain socket and drain caps are not included with product. They are available for separate purchase.

*2 When performing work using the flareless joints (accessory), refer to the instruction manual for flareless joints.

Safety Considerations

Refer also to the General Safety Considerations in the separate booklet.

	Read the precautions in this manual carefully before operating the unit.
	This appliance is filled with R32.

Read these **Safety Considerations for Installation** carefully before installing an air conditioner or heat pump. After completing the installation, make sure that the unit operates properly during the startup operation. Instruct the user on how to operate and maintain the unit. Inform users that they should store this installation manual with the operation manual for future reference.

Always use a licensed installer or contractor to install this product. Improper installation can result in water or refrigerant leakage, electric shock, fire, or explosion.

Meanings of **DANGER**, **WARNING**, **CAUTION**, and **NOTE** Symbols:

- DANGER** Indicates an imminently hazardous situation which, if not avoided, will result in death or serious injury.
- WARNING** Indicates a potentially hazardous situation which, if not avoided, could result in death or serious injury.
- CAUTION** Indicates a potentially hazardous situation which, if not avoided, may result in minor or moderate injury. It may also be used to alert against unsafe practices.
- NOTE** Indicates situations that may result in equipment or property damage accidents only.

DANGER

- Refrigerant gas is heavier than air and replaces oxygen. A massive leak can lead to oxygen depletion, especially in basements, and an asphyxiation hazard could occur leading to serious injury or death.
- Do not ground units to water pipes, gas pipes, telephone wires, or lightning rods as incomplete grounding can cause a severe shock hazard resulting in severe injury or death. Additionally, grounding to gas pipes could cause a gas leak and potential explosion causing severe injury or death.
- If refrigerant gas leaks during installation, ventilate the area immediately. Refrigerant gas may produce toxic gas if it comes into contact with fire. Exposure to this gas could cause severe injury or death.
- After completing the installation work, check that the refrigerant gas does not leak throughout the system.
- Do not install unit in an area where flammable materials are present due to risk of explosions that can cause serious injury or death.
- Safely dispose all packing and transportation materials in accordance with federal/state/local laws or ordinances. Packing materials such as nails and other metal or wood parts, including plastic packing materials used for transportation may cause injury or death by suffocation.
- All possible ignition sources, including cigarette smoking, should be kept sufficiently far away from the site of installation, repairing, removing and disposal.

WARNING

- Only qualified personnel licensed or certified in their jurisdiction must carry out the installation work. Installation must be done in accordance with this installation manual. Improper installation may result in water leakage, electric shock, or fire.
- Pipe-work including piping material, pipe routing, and installation shall include protection from physical damage in operation and service, and be in compliance with national and local codes and standards, such as ASHRAE 15, ASHRAE 15.2, IAPMO Uniform Mechanical Code, ICC International Mechanical Code, or CSA B52. All field joints shall be accessible for inspection prior to being covered or enclosed.
- When installing the unit in a small room, take measures to keep the refrigerant concentration from exceeding allowable safety limits. Excessive refrigerant leaks, in the event of an accident in a closed ambient space, can lead to oxygen deficiency.
- Use only specified accessories and parts for installation work. Failure to use specified parts may result in water leakage, electric shock, fire, or the unit falling.
- Install the air conditioner or heat pump on a foundation strong enough that it can withstand the weight of the unit. A foundation of insufficient strength may result in the unit falling and causing injury.
- Take into account strong winds, typhoons, or earthquakes when installing. Improper installation may result in the unit falling and causing accidents.
- The unit must have an uninterrupted, unbroken electrical ground to minimize the possibility of personal injury if an electrical fault should occur.
The electrical ground circuit may consist of an appropriately sized electrical wire connecting the ground lug in the unit and control box wire to the building's electrical service panel.
Other methods of grounding are permitted if performed in accordance with the "National Electrical Code" (NEC)/ "American National Standards Institute" (ANSI)/ "National Fire Protection Association" (NFPA) 70 and local/state codes.
In CANADA, electrical grounding is to be in accordance with the Canadian Electrical Code CSA C22.1.
Failure to observe this warning can result in electrical shock that can cause personal injury or death.
- Make sure that a separate power supply circuit is provided for this unit and that all electrical work is carried out by qualified personnel licensed or certified in their jurisdiction according to local, state, and national regulations. An insufficient power supply capacity or improper electrical construction may lead to electric shock or fire.
- Make sure that all wiring is secured, that specified wires are used, and that no external forces act on the terminal connections or wires. Improper connections or installation may result in fire.
- When wiring, position the wires so that the protection plate can be securely fastened. Improper positioning of the protection plate may result in electric shock, fire, or the terminals overheating.
- Before touching electrical parts, turn off the unit.
- The circuit must be protected with safety devices in accordance with local and national codes, i.e. a circuit breaker.
- Securely fasten the outdoor unit protection plate. If the protection plate is not installed properly, dust or water may enter the outdoor unit causing fire or electric shock.

- When installing or relocating the system, keep the refrigerant circuit free from substances other than the specified refrigerant (R32) such as air. Any presence of air or other foreign substance in the refrigerant circuit can cause an abnormal pressure rise or rupture, which may result in equipment damage and even injury.
- Do not change the setting of the protection devices. If the pressure switch, thermal switch, or other protection device is shorted and operated forcibly, or parts other than those specified by Daikin are used, fire or explosion may occur.
- Do not use means to accelerate the defrosting process (if possible) or to clean, other than those recommended by the manufacturer.
- The appliance must be stored in a room without continuously operating ignition sources (for example: open flames, an operating gas appliance or an operating electric heater).
- Do not pierce or burn.
- Be aware that refrigerants may not contain an odor.
- Comply with national gas regulations.
- The indoor equipment and pipes shall be securely mounted and guarded such that accidental rupture of equipment cannot occur from such events as moving furniture or reconstruction activities.

CAUTION

- Do not touch the switch with wet fingers. Touching a switch with wet fingers can cause electric shock.
- Do not allow children to play on or around the unit to prevent injury.
- Wear adequate personal protective equipment (protective gloves, safety glasses,...) when installing, maintaining or servicing the system.
- The heat exchanger fins are sharp enough to cut. To avoid injury, wear gloves or cover the fins while working around them.
- Do not touch the refrigerant pipes during and immediately after operation as the refrigerant pipes may be hot or cold, depending on the condition of the refrigerant flowing through the refrigerant piping, compressor, and other refrigerant cycle parts. Your hands may suffer burns or frostbite if you touch the refrigerant pipes. To avoid injury, give the pipes time to return to normal temperature or, if you must touch them, be sure to wear proper gloves.
- Install drain piping to ensure proper drainage. Improper drain piping may result in water leakage and property damage.
- Insulate piping to prevent condensation.
- Be careful when transporting the product.
- Do not turn off the power immediately after stopping operation. Always wait for at least 5 minutes before turning off the power. Otherwise, water leakage may occur.
- Do not use a charging cylinder. Using a charging cylinder may cause the refrigerant to deteriorate.
- Refrigerant R32 in the system must be kept clean, dry, and tight.
 - (a) Clean and Dry -- Foreign materials (including mineral oils such as SUNISO oil or moisture) should be prevented from getting into the system.
 - (b) Tight -- R32 does not contain any chlorine, does not destroy the ozone layer, and does not reduce the earth's protection against harmful ultraviolet radiation. R32 can contribute to the greenhouse effect if it is released. Therefore take proper measures to check for the tightness of the refrigerant piping installation. Read the chapter *Refrigerant Piping* and follow the procedures.

Safety Considerations

⚠ CAUTION

- The outdoor unit is for R32. See the catalog for indoor models that can be connected. Normal operation is not possible when connected to non-compatible indoor units.
- Remote controller (wireless kit) transmitting distance can be shorter than expected in rooms with electronic fluorescent lamps (inverter or rapid start types). Install the indoor unit far away from fluorescent lamps as much as possible.
- Indoor units are for indoor installation only. Outdoor units can be installed either outdoors or indoors.
- Do not install the air conditioner or heat pump in the following locations:
 - (a) Where a mineral oil mist or oil spray or vapor is produced, for example, in a kitchen. Plastic parts may deteriorate and fall off or result in water leakage.
 - (b) Where corrosive gas, such as sulfurous acid gas, is produced. Corroding copper pipes or soldered parts may result in refrigerant leakage.
 - (c) Near machinery emitting electromagnetic waves. Electromagnetic waves may disturb the operation of the control system and cause the unit to malfunction.
 - (d) Where flammable gas may leak, where there is carbon fiber, or ignitable dust suspension in the air, or where volatile flammables such as thinner or gasoline are handled. Operating the unit in such conditions can cause a fire.





- Take adequate measures to prevent the outdoor unit from being used as a shelter by small animals. Small animals making contact with electrical parts can cause malfunctions, smoke, or fire. Instruct the user to keep the area around the unit clean.
- Servicing shall be performed only as recommended by the manufacturer and licensed or certified in their jurisdiction.

⚠ NOTE

- The outdoor unit should be positioned where the unit and power supply wires (breaker panel to outdoor unit) are at least 10ft (3m) away from any televisions or radios. (The unit may cause interference with the picture or sound.) Depending on the radio waves, a distance of 10ft (3m) may not be sufficient to eliminate the noise.
- Dismantling the unit, treatment of the refrigerant, oil and additional parts must be done in accordance with the relevant local, state, and national regulations.
- Only use tools for R32 or R410A, such as a gauge manifold, charge hose, gas leak detector, reverse flow check valve, refrigerant charge base, vacuum gauge, or refrigerant recovery equipment.
- If the conventional refrigerant and refrigerant oil are mixed in R32, the refrigerant may deteriorate.
- As maximum allowable pressure is 604psi (4.17MPa), the wall thickness of field-installed pipes should be selected in accordance with the relevant local, state, and national regulations.

RN008(R32)-U

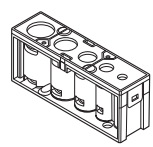
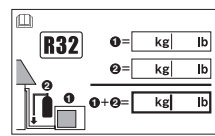
Accessories

<p>(A) Installation manual</p>	<p>1</p>	<p>(B) Flareless joint set</p> <div style="display: flex; justify-content: space-around; align-items: center;">   </div> <p>For liquid pipe For gas pipe</p> <p>2 sets: 1 set is for the indoor unit and 1 set is for the outdoor unit.</p>	<p>2</p>
<p>(C) Instruction manual for flareless joints</p>	<p>1</p>	<p>(D) Marking gauge</p> 	<p>1</p>
<p>(E) Refrigerant charge label</p>  <p>Affix near the manufacturer's label.</p>	<p>1</p>	<p>or</p> <p>Plastic flare nut with marking gauge functionality</p> <div style="display: flex; justify-content: space-around; align-items: center;">   </div> <p>For liquid pipe For gas pipe</p>	<p>1</p>
<p>(F) Warranty</p>	<p>1</p>	<p>The marking gauge or plastic flare nut with marking gauge functionality are to be used when using the flareless joint sets.</p>	<p>1</p>
<p>(G) General Safety Considerations</p>	<p>1</p>	<p>The marking gauge or plastic flare nut with marking gauge functionality are to be used when using the flareless joint sets.</p>	<p>1</p>

Installation Space Requirements

- Position the unit on a horizontal surface. Any tilt in the unit should be 3° or less to the horizontal.
- Where a wall or other obstacle is in the path of the outdoor unit's intake or exhaust airflow, follow the installation space requirements below.
- For any of the below installation patterns, the wall height on the outlet side should be 47-1/4 inch (1200mm) or less.
- Secure as much installation space around the unit as the location allows, as more space will result in more efficient operation.

Wall facing one side

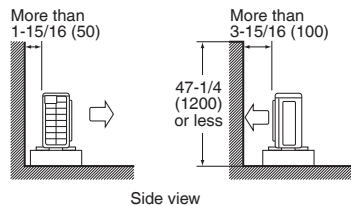

Walls facing two sides

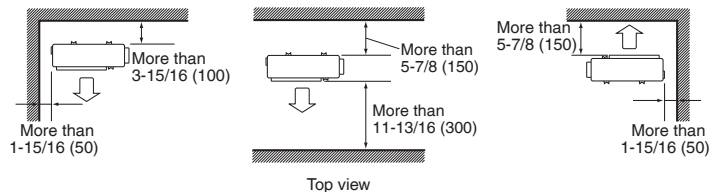

Walls facing three sides

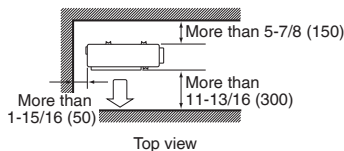

When installed as in the figure on the left, it is recommended to either change the orientation of the outdoor unit outlet side or use the air direction adjustment grille (sold separately).

unit: inch (mm)

Precautions for Selecting a Location

- 1) Choose a place solid enough to bear the weight and vibration of the unit, where the operating sound will not be amplified.
- 2) Choose a location where the air discharged from the unit or the operating sound will not cause a nuisance to the neighbors of the user.
- 3) Avoid locations, such as near bedrooms, where the operating sound may cause disturbance.
- 4) There must be sufficient space to carry the unit into and out of the site.
- 5) There must be sufficient space for air passage and no obstructions around the air inlet and the air outlet.
- 6) In coastal areas or other places with a salty atmosphere or one containing sulfate gas, corrosion may shorten the life of the air conditioner.
- 7) Since water will flow from the drain of the outdoor unit, do not place anything under the unit which must be kept away from moisture.
- 8) A location where flammable gas does not leak. Position at least 6-5/8ft (2m) from propane gas cylinders.

NOTE

Cannot be installed suspended from a ceiling or stacked.

CAUTION

When operating the air conditioner in a low outdoor ambient temperature, be sure to follow the instructions described below.

- To prevent exposure to wind, install the outdoor unit with its suction side facing the wall.
- Never install the outdoor unit at a site where the suction side may be exposed directly to wind.
- To prevent exposure to wind, it is recommended to install a baffle plate on the air discharge side of the outdoor unit.
- In heavy snow areas, select an installation site where the snow will not affect the unit.
- If there is a likelihood of snow accumulating on the outdoor unit, attach a snow protection hood.

- Construct a large canopy.
- Construct a pedestal.

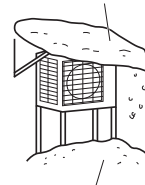

Install the unit high enough off the ground to prevent burying in snow.

Precautions on Installation

- Check the strength and level of the installation surface so that the unit does not cause any operating vibrations or noise after installation.
- Fix the unit in place securely using foundation bolts, as in the figure. (Prepare 4 sets of 5/16 inch (M8) or 3/8 inch (M10) foundation bolts, nuts and washers; all sold separately.)
- It is best to screw in the foundation bolts until their ends are 3/4 inch (20mm) from the foundation surface.

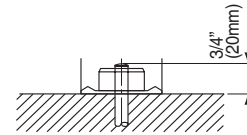

Outdoor Unit Installation Diagram

Max. allowable piping length	65-5/8ft (20m)
** Min. allowable piping length	10ft (3m)
Max. allowable piping height	49-1/4ft (15m)
* Additional refrigerant required for refrigerant pipe exceeding 49-1/4ft (15m) in length.	0.22oz/ft (20g/m)
Gas pipe	O.D. 3/8 inch (9.5mm)
Liquid pipe	O.D. 1/4 inch (6.4mm)

Refrigerant piping must be kept to a minimum.

*Be sure to add the proper amount of additional refrigerant.

Failure to do so may result in reduced performance.

**The suggested shortest pipe length is 10ft (3m), in order to avoid noise from the outdoor unit and vibration.

(Mechanical noise and vibration may occur depending on how the unit is installed and the environment in which it is used.)

If strong wind blows into the air discharge side from the front and there is a danger that the fan may be damaged, change the orientation of the air discharge side of the outdoor unit or use an air direction adjustment grille (sold separately).

In sites with poor drainage, use block bases for the outdoor unit. Adjust foot height until the unit is level. Otherwise, water leakage or pooling of water may occur.

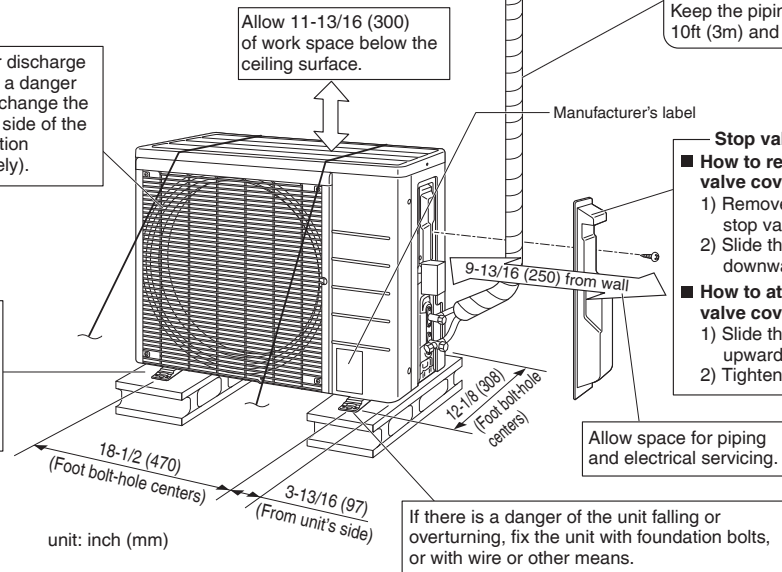

Refrigerant charge label

Please fill in with indelible ink,

- ① the factory refrigerant charge of the product,
 - ② the additional refrigerant amount charged in the field and
 - ① + ② the total refrigerant charge
- on the refrigerant charge label supplied with the product. Affix the refrigerant charge label near the manufacturer's label after filling it out.

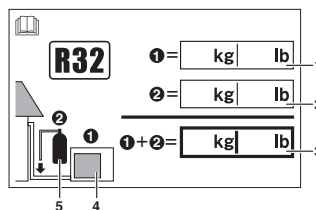

- 1 factory refrigerant charge of the product: see unit manufacturer's label
- 2 additional refrigerant amount charged in the field
- 3 total refrigerant charge
- 4 outdoor unit
- 5 refrigerant cylinder and manifold for charging

Selecting a Location for Installation of the Indoor Units

- Minimum required floor area (A_{min})

The minimum required floor area of the room where the indoor unit is installed varies depending on the installation height and refrigerant amount.

Indoor unit installation height (m)	h (m)					
	0.6	1.8	2.0	2.2	2.4	2.6
Refrigerant amount (kg)	No restriction					
< 1.84						
1.9	31.0	6.9	6.2	5.6	5.2	4.8
2.0	34.3	7.3	6.5	5.9	5.4	5.0
2.1	37.8	7.6	6.9	6.2	5.7	5.3
2.2	41.5	8.0	7.2	6.5	6.0	5.5
2.3	45.4	8.4	7.5	6.8	6.3	5.8
2.4	49.4	8.7	7.8	7.1	6.5	6.0
2.5	53.6	9.1	8.2	7.4	6.8	6.3
2.6	58.0	9.4	8.5	7.7	7.1	6.5
2.7	62.6	9.8	8.8	8.0	7.4	6.8
2.8	67.3	10.2	9.2	8.3	7.6	7.0
2.9	72.2	10.5	9.5	8.6	7.9	7.3
3.0	77.2	10.9	9.8	8.9	8.2	7.5
3.1	82.5	11.3	10.1	9.2	8.4	7.8
3.2	87.9	11.6	10.5	9.5	8.7	8.0
3.3	93.4	12.0	10.8	9.8	9.0	8.3
3.4	99.2	12.3	11.1	10.1	9.3	8.5
3.5	105.1	12.7	11.4	10.4	9.5	8.8
3.6	111.2	13.1	11.8	10.7	9.8	9.0
3.7	117.5	13.4	12.1	11.0	10.1	9.3
3.8	123.9	13.8	12.4	11.3	10.3	9.6
3.9	130.5	14.5	12.7	11.6	10.6	9.8
4.0	137.3	15.3	13.1	11.9	10.9	10.1
4.1	144.2	16.0	13.4	12.2	11.2	10.3
4.2	151.4	16.8	13.7	12.5	11.4	10.6
4.3	158.7	17.6	14.3	12.8	11.7	10.8
4.4	166.1	18.5	15.0	13.1	12.0	11.1

Indoor unit installation height (ft)	h (ft)					
	2.0	5.9	6.6	7.2	7.9	8.5
Refrigerant amount (lb)	No restriction					
< 4.05						
4.2	333	74	67	61	56	51
4.4	369	78	70	64	59	54
4.6	407	82	74	67	62	57
4.9	447	86	77	70	64	60
5.1	489	90	81	74	67	62
5.3	532	94	84	77	70	65
5.5	577	98	88	80	73	68
5.7	624	102	91	83	76	70
6.0	673	106	95	86	79	73
6.2	724	109	98	90	82	76
6.4	777	113	102	93	85	78
6.6	831	117	106	96	88	81
6.8	888	121	109	99	91	84
7.1	946	125	113	102	94	87
7.3	1006	129	116	106	97	89
7.5	1068	133	120	109	100	92
7.7	1131	137	123	112	103	95
7.9	1197	141	127	115	106	97
8.2	1264	145	130	118	108	100
8.4	1334	149	134	122	111	103
8.6	1405	156	137	125	114	106
8.8	1478	164	141	128	117	108
9.0	1553	173	144	131	120	111
9.3	1629	181	148	134	123	114
9.5	1708	190	154	138	126	116
9.7	1788	199	161	141	129	119

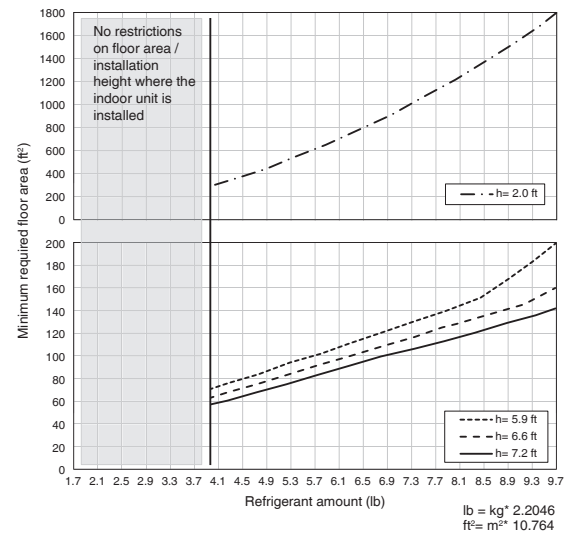
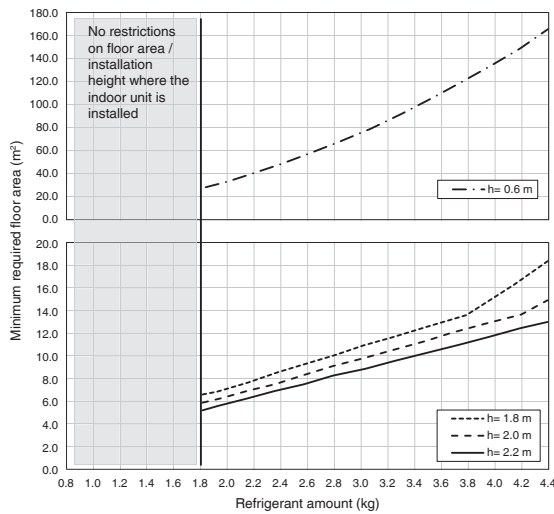

lb = kg * 2.2046
ft² = m² * 10.764

Outdoor Unit Installation

1. Installing the outdoor unit

- When installing the outdoor unit, refer to “Precautions for Selecting a Location” on page 4 and “Outdoor Unit Installation Diagram” on page 5.
- If drain work is necessary, follow the procedures below.

2. Drain work

- Only perform drain work if it is necessary.
- The drain socket and drain caps are available for separate purchase.

⚠ CAUTION

In cold areas, do not use a drain socket, drain caps (1, 2) and a drain hose with the outdoor unit. (Drain water may freeze, impairing heating performance.)

- If the drain port is covered by a mounting base or floor surface, place additional foot bases of at least 1-1/4 inch (30mm) in height under the outdoor unit's feet.
- 1) Attach drain cap (1) and drain cap (2).
 - 2) Attach drain socket to the shape of drain hole and fix it by turning.
 - When attaching drain socket to the bottom frame, make sure to connect the drain hose to the drain socket first.

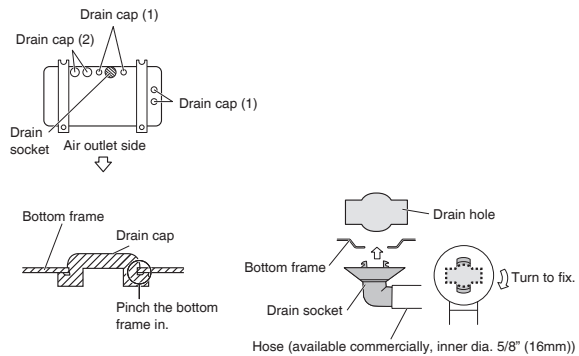

3. Flaring the pipe end

When performing work using the flareless joints (accessory), refer to the instruction manual for flareless joints.

⚠ WARNING

- Do not apply mineral oil to the flare.
- Prevent mineral oil from getting into the system as this would reduce the service life of the units.
- Never use piping which has been used for previous installations. Only use parts which are delivered with this unit.
- Never install a dryer to this R32 unit in order to guarantee its service life.
- The drying material may dissolve and damage the system.
- Improper flaring may result in refrigerant gas leakage.

⚠ CAUTION

Do not reuse joints which have been used once already.

- 1) Cut the pipe end with a pipe cutter.
- 2) Remove burrs with the cut surface facing downward, so that the filings do not enter the pipe.
- 3) Put the flare nut on the pipe.
- 4) Flare the pipe.
- 5) Check that the flaring has been done correctly.

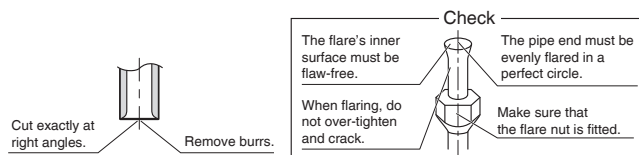

Flaring

Set exactly at the position shown below.

Die	Flare tool for R32 or R410A		Conventional flare tool	
	Clutch-type	Clutch-type (Rigid-type)	Wing-nut type (Imperial-type)	
A	0-0.020 inch (0-0.5mm)	0.039-0.059 inch (1.0-1.5mm)	0.059-0.079 inch (1.5-2.0mm)	

4. Refrigerant piping

When performing work using the flareless joints (accessory), refer to the instruction manual for flareless joints.

⚠ CAUTION

- Use the flare nut fixed to the main unit. (This is to prevent the flare nut from cracking as a result of deterioration over time.)
- Use a torque wrench when tightening the flare nuts to prevent damage to the flare nuts and gas leakage.
- Excessive tightening of the flare nut can result in the flare nut cracking in the long term, leading to gas leakage.

- Align the centers of both flares and tighten the flare nuts 3 or 4 turns by hand, then tighten them fully with a spanner and a torque wrench.

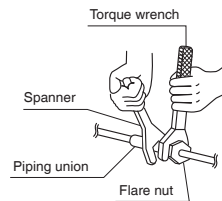
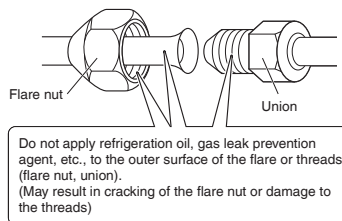

Tightening torque

Piping connection

Flare nut	
Gas side 3/8 inch (9.5mm)	Liquid side 1/4 inch (6.4mm)
24-1/8 – 29-3/8lbf • ft (32.7-39.9N • m)	10-1/2 – 12-5/8lbf • ft (14.2-17.2N • m)

Valve cap

Width across flats	
11/16 inch (17mm)	3/4 inch (19mm)
10-1/2 – 12-5/8lbf • ft (14.2-17.2N • m)	12-5/8 – 15-3/8lbf • ft (17.1-20.9N • m)

Service port cap

7-7/8 – 10-7/8lbf • ft (10.7-14.7N • m)
--

Cautions on pipe handling

- Protect the open end of the pipe from dust and moisture.
- All pipe bends should be as gentle as possible. Use a pipe bender for bending.

Selection of copper and heat insulation materials

When using commercial copper pipes and fittings, observe the following:

- Insulation material: Polyethylene foam
Heat transfer rate: 0.041 to 0.052W/mK (0.024 to 0.030Btu/ft•°F) (0.035 to 0.045kcal/mh•°C)
Be sure to use insulation that is designed for use with HVAC Systems.
- ACR Copper only.
- Be sure to insulate both the gas and liquid piping and observe the insulation dimensions as below.

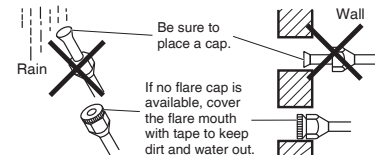

	Piping size	Minimum bend radius	Piping thickness	Thermal insulation size	Thermal insulation thickness
Gas side	O.D. 3/8 inch (9.5mm)	1-3/16 inch (30mm) or more	0.031 inch (0.8mm) (C1220T-O)	I.D. 15/32-19/32 inch (12-15mm)	13/32 inch (10mm) Min.
Liquid side	O.D. 1/4 inch (6.4mm)	1-3/16 inch (30mm) or more	0.031 inch (0.8mm) (C1220T-O)	I.D. 5/16-13/32 inch (8-10mm)	

- Use separate thermal insulation pipes for gas and liquid refrigerant pipes.
- Using finishing tape, bundle and wrap the indoor unit piping and drain hose together so that the drain hose is below the other piping.

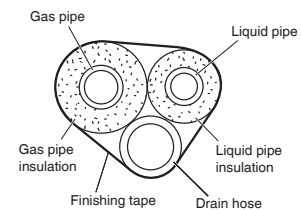

Outdoor Unit Installation

5. Pressure test and evacuating system

⚠ WARNING

- Make sure that air or any matter other than refrigerant (R32) does not get into the refrigeration cycle.
- If refrigerant gas leaks should occur, ventilate the room as soon and as much as possible.
- R32, as well as other refrigerants, should always be recovered and never be released directly into the environment.
- **Use tools for R32 or R410A (such as the gauge manifold, charging hose, or vacuum pump adapter).**

⚠ CAUTION

It is highly recommended that you do not open/close the stop valves when the outdoor temperature is below -5°F (-21°C) as this may result in refrigerant leakage.

- When piping work is complete, it is necessary to perform a pressure test and evacuate system with a vacuum pump.
- If using additional refrigerant, purge the air from the refrigerant pipes and indoor unit using a vacuum pump, then charge additional refrigerant.
- Use a hexagonal wrench ($3/16$ inch (4mm)) to operate the stop valve rod.
- All refrigerant pipe joints should be tightened with a torque wrench to the specified tightening torque.

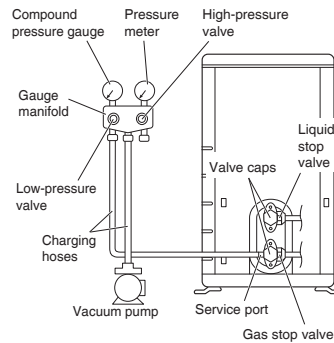

- 1) Pressurize the liquid pipe and gas pipe from the service port of gas stop valve to 604psi (4.17MPa) (do not pressurize more than 604psi (4.17MPa)) for 1 hour minimum, 24 hours recommended. If there is a pressure drop, check for leaks, make repairs and perform the pressure test again.
- 2) Connect the gauge manifold's charging hose to the gas stop valve's service port.
- 3) Fully open the low-pressure valve (Lo) on the gauge manifold and fully close the high-pressure valve (Hi). (High-pressure valve will require no further operation.)
- 4) Evacuate system using vacuum pump to below 500 microns for 1 hour minimum.
- 5) Close the low-pressure valve (Lo) on the gauge manifold and stop vacuum pumping. (Maintain this condition for a few minutes to make sure that the compound pressure gauge pointer does not swing back.)*1
- 6) Remove the valve caps from the liquid stop valve and gas stop valve.
- 7) To open the liquid stop valve, turn the rod of the valve 90° counter-clockwise using a hexagonal wrench. Close it after 5 seconds, and check for gas leakage. Using soapy water, check for gas leakage from the indoor unit's flare and outdoor unit's flare and valve rods. After the check is complete, wipe all soapy water off *2.
- 8) Disconnect the charging hoses from the service port for the gas stop valve, then fully open the liquid and gas stop valves. (Do not attempt to turn the valve rods further than they can go.)
- 9) Tighten the valve caps and service port caps for the liquid and gas stop valves with a torque wrench to the specified torques. Refer to "4. Refrigerant piping" on page 8 for details.

*1 If the compound pressure gauge pointer swings back, the refrigerant may have water content or there may be a loose pipe joint. Check all pipe joints and retighten nuts as needed, then repeat steps 3) through 5).

*2 **Under no circumstances shall potential sources of ignition be used in the searching for or detection of refrigerant leaks. A halide torch (or any other detector using a naked flame) shall not be used. Do not use substances containing chlorine and electronic leak detection for gas leak detection.**

Wiring

⚠ WARNING

RISK OF ELECTRIC SHOCK CAUSE INJURY OR DEATH.

- System contains oversize protective earthing (grounding) terminal which shall be properly connected.
- Do not ground units to water pipes, gas pipes, telephone wires, or lightning rods as incomplete grounding can cause a severe shock hazard resulting in severe injury or death. Additionally, grounding to gas pipes could cause a gas leak and potential explosion causing severe injury or death.
- Do not use tapped wires, extension cords, or starburst connections, as they may cause overheating, electric shock, or fire.
- Do not use locally purchased electrical parts inside the product. (Do not branch the power for the drain pump, etc., from the terminal block.) Doing so may cause electric shock or fire.
- The circuit must be protected with safety devices in accordance with local and national codes, i.e. a circuit breaker.
- Use an all-pole disconnection type circuit breaker with at least 1/8 inch (3mm) between the contact point gaps.
- When carrying out wiring, take care not to pull at the conduit.
- Do not connect the power wire to the indoor unit. Doing so may cause electric shock or fire.
- Do not turn on the circuit breaker until all work is completed.

⚠ CAUTION

Precautions to be taken for power supply wiring

Recommend stranded cable for interunit wiring. Local code always supersedes recommendation.

- For stranded wires, make sure to use the round crimp-style terminal for connection to the power supply terminal block. Place the round crimp-style terminals on the wires up to the covered part and secure in place.

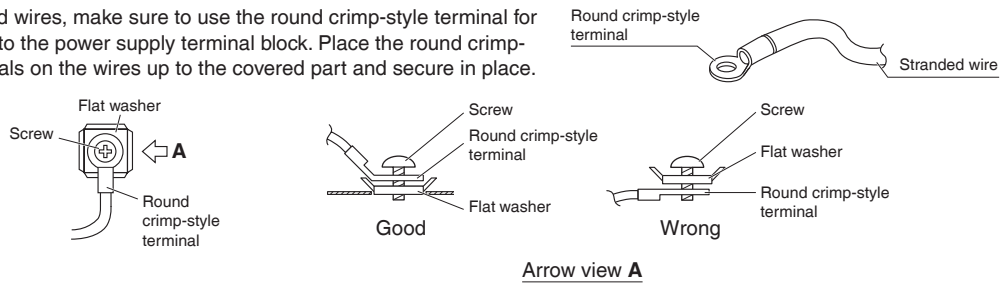

- If solid core wire must be used, be sure to curl the end of the lead. Improper work may cause heat and fire.

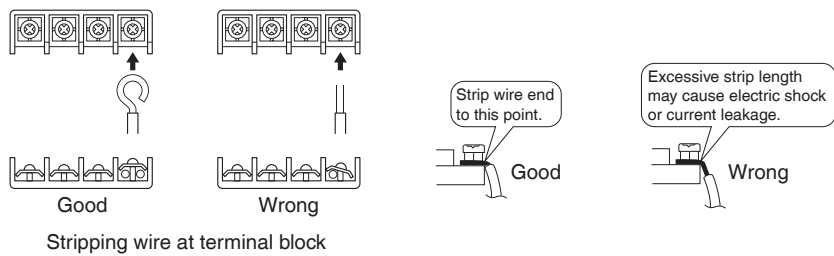

Wiring

[Method of mounting conduit]

- When wiring, remove the top plate and look at the wiring diagram on the back of the top plate.
 - A protection plate is fixed for protection from the high-voltage section.
- 1) Dismount the stop valve cover by removing the screw.
 - 2) Dismount the protection plate by removing the 2 screws.
 - 3) Dismount the conduit mounting cover by removing the 2 screws.
 - 4) Pass wires through the conduit and secure them with a lock nut.

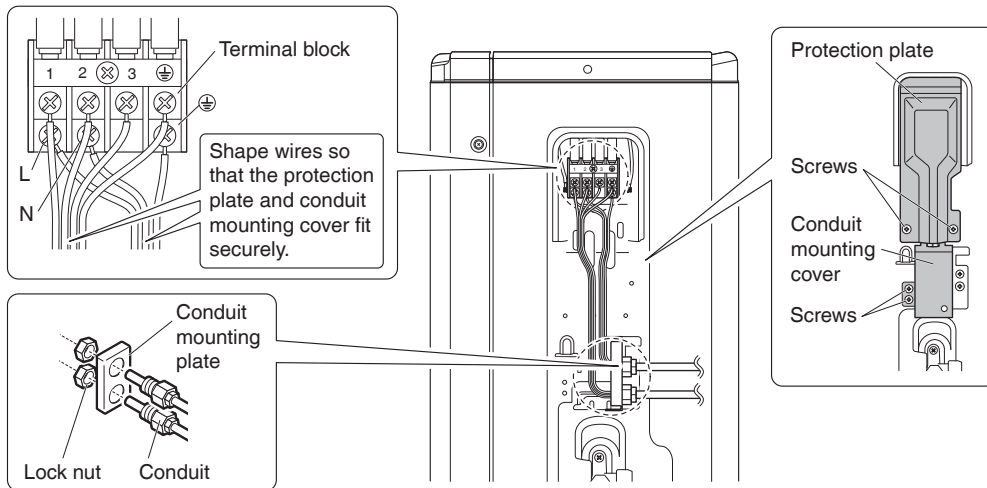
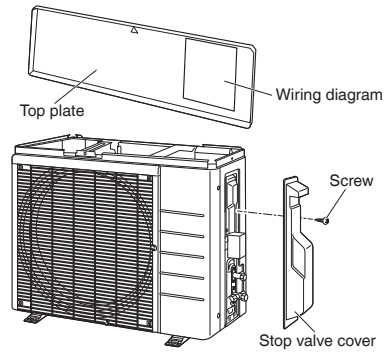

[Wiring procedure]

- 1) Strip the insulation from the wire (3/4 inch (20mm)).
- 2) Connect the inter-unit wires between the indoor and outdoor units so that the terminal numbers match. Tighten the terminal screws securely. It is recommended that a slot-head screwdriver be used to tighten the screws.
- 3) Pull the wire lightly to make sure that it does not disconnect.
- 4) After completing the work, reattach the conduit mounting cover, the protection plate, and the stop valve cover to its original position.

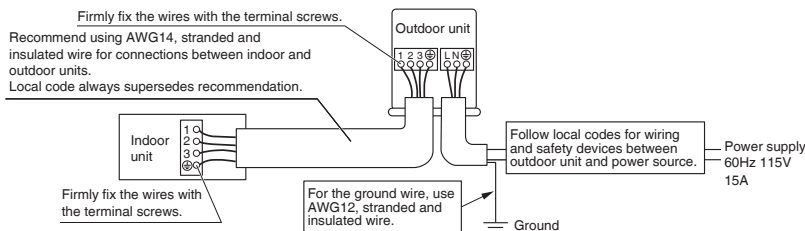

Ground

This air conditioner must be grounded. For grounding, follow all local, and state electrical codes.

NOTE

Take care to ensure that all wiring between indoor unit and outdoor unit has a consistent connection. Any splices can cause communication errors.

Pump Down Operation

In order to protect the environment, be sure to pump down when relocating or disposing of the unit.

- 1) Remove the valve caps from the liquid stop valve and gas stop valve.
- 2) Begin forced cooling operation.
- 3) After 5 to 10 minutes, close the liquid stop valve with a hexagonal wrench.
- 4) After 2 to 3 minutes, close the gas stop valve and stop forced cooling operation.
- 5) Attach the valve caps once procedures are complete.

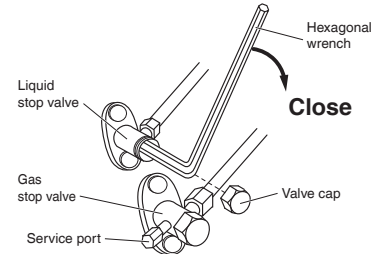

Forced cooling operation

Refer to the installation manual for the indoor unit.

Trial Operation and Testing

- When trial operation is conducted directly after the circuit breaker is turned on, in some cases no air will be output for about 15 minutes in order to protect the air conditioner.

1. Trial operation and testing

Refer to the installation manual for the indoor unit.

2. Test items

Test items	Symptom	Check
Indoor and outdoor units are installed securely.	Fall, vibration, noise	
No refrigerant gas leaks.	Incomplete cooling/heating function	
Refrigerant gas and liquid pipes and indoor drain hose extension are thermally insulated.	Water leakage	
Draining line is properly installed.	Water leakage	
System is properly grounded.	Electrical leakage	
Only specified wires are used for all wiring, and all wires are connected correctly.	No operation or burn damage	
Indoor or outdoor unit's air inlet or air outlet are unobstructed.	Incomplete cooling/heating function	
Stop valves are opened.	Incomplete cooling/heating function	
Indoor unit properly receives remote control commands.	No operation	

11.3 Flareless Joint



Refrigerant piping work Flareless joint instruction manual

Preparation

- Perform any bending near the flareless joints before connecting them.
- Prepare the marking gauge or plastic flare nut with marking gauge function (one of which is supplied with the product).
- The plastic flare nut with marking gauge functionality shall hereinafter be referred to as the "plastic nut".

WARNING

- Be sure to perform refrigerant piping work in accordance with this instruction manual.
- For safety considerations and details on product installation work related to flareless joint installation, be sure to read the installation manual included with the product.
- If the refrigerant piping is improperly installed, air may get mixed in, resulting in explosion, fire, or injury.
- Use a pipe cutter specially made for R32 or R410A.
- When polishing the surface of the piping to remove oxides, do not polish so much that the wall thickness of the piping becomes thinner than the minimum wall thickness required.
- Do not disassemble the flareless joints.
- When working in high places, work with a scaffold stable.
- Connect the flareless joints securely at 1 location at a time.
- Do not use flareless joints that have been deformed due to being dropped, etc.
- To prevent dust and dirt from entering the piping, and to prevent moisture from entering, protect the piping by pinching or taping.
- Do not reuse flareless joints that have previously been installed.
- Use the marking gauge or plastic nut.
- If pipes are not inserted deeply enough, refrigerant leakage may result.
- Do not reuse the plastic nut.
- If reused, the plastic may be worn away making it difficult to check for ovality of the piping and external or internal burrs.
- If, when the installation is complete, the length of the on-site piping is insufficient, there is a risk of the piping disconnecting resulting in refrigerant leakage.

This product is compatible with R32 and R410A refrigerant.

Be sure to observe the items listed on the right when working.

<Flareless joint>

(For pipe size ϕ 19.05 only)

Unit: inch (mm)

Shape	Piping Size (ϕ)	Flareless joint dimensions	
		A	B
I	1/4 (6.35)	1-11/32 (33.9)	21/32 (17.0)
	3/8 (9.52)	1-1/2 (38.1)	7/8 (22.0)
	1/2 (12.70)	1-21/32 (42.0)	1-1/32 (26.0)
	5/8 (15.88)	1-13/16 (46.3)	1-5/32 (29.0)
II	3/4 (19.05)	2-3/32 (53.0)	1-13/32 (36.0)

1. Preparation of marking gauge

Prepare the marking gauge or plastic nut.

CAUTION

Do not touch the marking gauge part when working with the plastic nut. If force is applied to the marking gauge part, the plastic may become deformed, making it difficult to check for ovality of the piping and external or internal burrs.

2. Cutting of thermal insulation (piping)

Being careful not to damage the piping, cut away the thermal insulation in the cylindrical direction. (See Fig. 1)

Unit: inch (mm)

Piping Size (ϕ)	Cut length
1/4 (6.35)	2-3/8 (60) or more
3/8 (9.52)	
1/2 (12.70)	
5/8 (15.88)	
3/4 (19.05)	

Prohibited

Do not cut in horizontally (lengthwise) using a cutting tool. Horizontal (lengthwise) scratches may cause refrigerant leakage.

3. Cutting of piping

- Ensure that the on-site piping is long enough to reach the edge of the connecting part. (See Fig. 2-1)
If, when the installation is complete, the length of the on-site piping is insufficient, there is a risk of the piping disconnecting resulting in refrigerant leakage.
- Use a pipe cutter to cut at a right angle to the piping. (See Fig. 2-2)

CAUTION

Cut gradually and slowly to prevent deformation of the piping.

4. Checking of piping

- Cut away the section of the flareless joint for insertion if it has any scratches or bends, or if it is not completely round or shows signs of thermal damage. (See Fig. 3)
- Straighten the section of piping for insertion.
- If any foreign matter is adhered to the inner or outer surfaces, remove it.

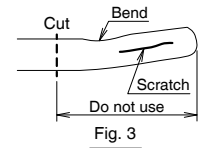

CAUTION

- If the piping can be easily inserted into the marking gauge, it is within acceptable limits in regard to straightness and roundness.
- If you are using existing piping, polish the piping surface in the cylindrical direction with a fine sandpaper of 1,000 grit or more to remove oxides.

5. Chamfering of piping

- External chamfering: As a guide, chamfer away about half the wall thickness.
- Internal chamfering: Continue chamfering until there are no burrs. (See Fig. 4)

CAUTION

- If the outer surface is not chamfered, the sealing material inside the flareless joint may be damaged, and refrigerant may leak.
- If the inner surface is not chamfered, it may cause the piping to be inserted incorrectly or the flow rate may not be able to be secured.
- When chamfering the piping, be careful not to let chips get inside the piping.

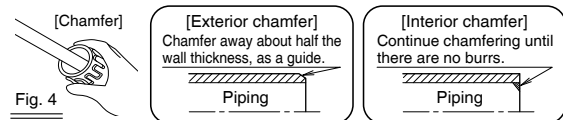

6. Insertion markings setting up

WARNING

Be sure to perform marking work to control the insertion allowance for piping. Insufficient piping insertion may cause refrigerant leakage.

- Insert the pipe fully into the marking gauge or plastic nut to check pipe ovality and that the pipe is clear of external and internal burrs.
- Using the confirmation window, make sure that the piping is inserted all the way into the marking gauge.
- Make a mark through marking hole with an oil-based pen, etc. (2 locations) (See Fig. 5-1, 5-2)
- Markings made with oil-based pen may be difficult to see in dark surroundings (such as in the ceiling). Add markers using vinyl tape, etc. as much as possible to improve visibility. (See Fig. 5-3)

CAUTION

Do not force the pipe into the marking gauge or plastic nut. If the piping cannot be inserted into the marking gauge or plastic nut smoothly, correct the problem and chamfer the piping again. Forcibly inserting the piping may damage/scratch the marking gauge or plastic nut causing debris to adhere to the inside of the piping.

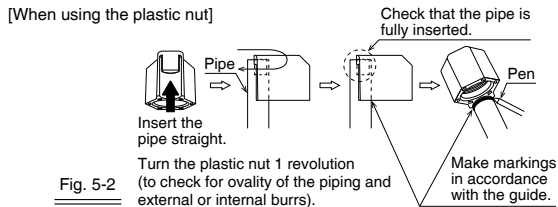
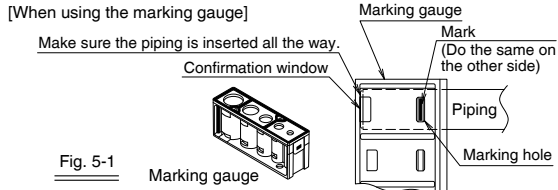

CAUTION
Keep the pipe straight when inserting it into or removing it from the plastic nut. If the pipe is inserted or removed at an angle, the marking gauge part may get damaged. In the event that it is damaged, do not use it.

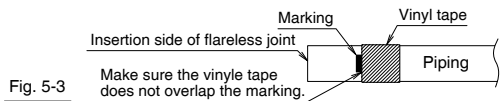

About installation work

When attaching flareless joints to the indoor unit, work in the order of 7 → 8 below.
When attaching flareless joints to the outdoor unit, work in the order of 8 → 7 below.

7. Insertion of piping

- Make sure that there is no dust or dirt inside the flareless joint.
- Insert the pipe straight and firmly all the way into the flareless joint. Anti-release tabs will engage. (See Fig. 6)
*There are tabs inside the flareless joint, creating some resistance. Insertion resistance is much greater for piping sizes of $\phi 1/2$ and above as compared to sizes $\phi 1/4$ and $\phi 3/8$.
*While the black line on the surface of the flareless joint provides a guideline for pipe insertion depth, do not use this guideline alone to determine the insertion depth when inserting the piping.
- Make sure the marking is at the base of the flareless joint end.

Prohibited

Do not insert the piping at an angle or use a tool to hit it and drive it into the flareless joint. The action described above might damage the piping or sealing material causing refrigerant leaks.

CAUTION

- If the piping cannot be inserted into the flareless joint, the marking gauge or plastic nut you used may be damaged. Please replace the marking gauge or plastic nut.
- Insert straight until the marking reaches or disappears under the end of the flareless joint.
- After piping has been inserted, it cannot be removed due to the anti-release mechanism. Forcibly pulling out the piping will result in damage. To remove, cut out the piping and use a new flareless joint.

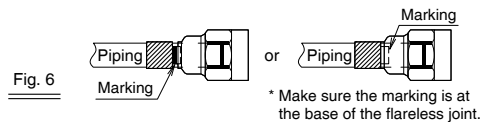
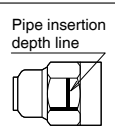

8. Hand-tightening of flareless joint connections

- Make sure that there is no dust or dirt inside the flareless joint, or inside the connector portion.
- Turn the flareless joint by hand and tighten it until it will not turn any more. (See Fig. 7 and Fig. 8)

CAUTION

There is lubricant (white) on the threads of the flareless joint. Make sure that no lubricant gets on the connector portion (other than the screw part).

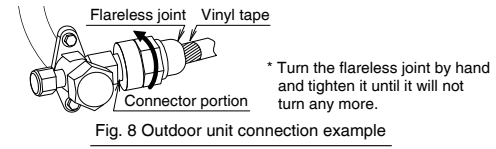
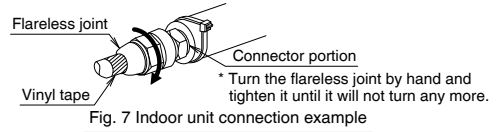

9. Checking the position of the insertion depth marking

Check again that the marking is at the base of the flareless joint. (See Fig. 9)
*Make sure that the width of the bare pipe is smaller than width A shown in Fig. 9. If the width is larger than A, the tabs may not be engaged and the pipe may not be inserted sufficiently.
In this case, insert the pipe straight and firmly all the way in again.

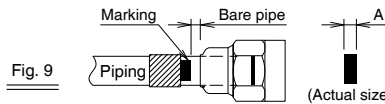

10. Marking

- Mark the flareless joint and the connector portion. (See Fig. 10)

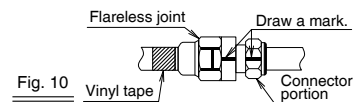

11. Tightening of the nuts

- Secure the flareless joint and the connector portion using adjustable spanners, then, using the marking or the characters printed on the flareless joint as a guide, rotate the flareless joint 1 time to tighten it. (See Fig. 11 and 12)
Be sure to use 2 adjustable for this purpose.

CAUTION

- Do not tighten excessively as this may damage the flareless joint and cause cracking over time.
- After tightening, the position of the marking on the piping inserted in step 7 (Fig. 6) will change.
- If you do not use 2 adjustable spanners, refrigerant leakage may result.

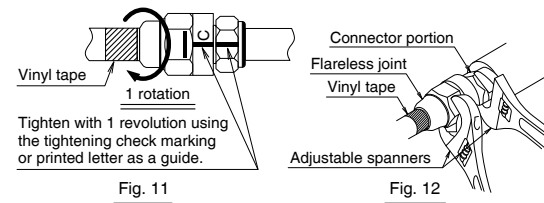

12. Airtightness testing and refrigerant leakage inspection

- Perform an airtightness test and refrigerant leakage inspection of the piping connections.
- For warnings and precautions, be sure to check the installation manual attached to the product unit.
- After completing the inspection, perform thermal insulation work.
- For airtightness test, refrigerant leak inspection, insulation work, refer to the installation manual attached to the product unit.

13. Precautions after installation

- After connecting the flareless joints, do not twist the flareless joints or the piping.
- If connecting bent sections of piping bend the piping in advance, and then attach flareless joints and connect the piping sections. After tightening, do not bend the piping. (See Fig. 13)
- Do not apply force horizontally or vertically to the piping to which the flareless joint is connected. (See Fig. 14)
- Do not reuse flareless joints that have previously been installed.

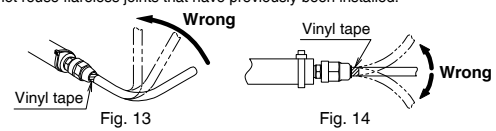



12. Operation Manual

Read Before Operation

Safety Considerations





Refer also to the General Safety Considerations in the separate booklet.

	Read the precautions in this manual carefully before operating the unit.
	This appliance is filled with R32.

Read these **Safety Considerations for Operations** carefully before operating an air conditioner or heat pump.

Make sure that the unit operates properly during the startup operation. Instruct the user on how to operate and maintain the unit. Inform users that they should store this operation manual with the installation manual for future reference.

Meanings of **DANGER**, **WARNING**, **CAUTION**, and **NOTE** Symbols:

-  **DANGER** Indicates an imminently hazardous situation which, if not avoided, will result in death or serious injury.
-  **WARNING** Indicates a potentially hazardous situation which, if not avoided, could result in death or serious injury.
-  **CAUTION** Indicates a potentially hazardous situation which, if not avoided, may result in minor or moderate injury. It may also be used to alert against unsafe practices.
-  **NOTE** Indicates situations that may result in equipment or property-damage accidents only.

DANGER

- Do not install the unit in an area where flammable materials are present due to risk of explosion resulting in serious injury or death.
- Any abnormalities in the operation of the air conditioner or heat pump, such as smoke or fire, could result in severe injury or death. Turn off the power and contact your dealer immediately.
- Refrigerant gas may produce toxic gas if it comes into contact with fire, such as from a fan heater, stove, or cooking device. Exposure to this gas could cause severe injury or death.
- For refrigerant leakage, consult your dealer. Refrigerant gas is heavier than air and replaces oxygen. A massive leak could lead to oxygen depletion, especially in basements, and an asphyxiation hazard could occur leading to serious injury or death.
- If equipment utilizing a burner is used in the same room as the air conditioner or heat pump, there is the danger of oxygen deficiency which could lead to an asphyxiation hazard resulting in serious injury or death. Be sure to ventilate the room sufficiently to avoid this hazard.
- Safely dispose of the packing materials. Packing materials, such as nails and other metal or wooden parts, may cause stabs or other injuries.

- Tear apart and throw away plastic packaging bags so that children will not play with them. Children playing with plastic bags face the danger of death by suffocation.

WARNING

- Contact your dealer for repair and maintenance. Improper repair and maintenance may result in water leakage, electric shock, and fire. Only use accessories made by Daikin that are specifically designed for use with the equipment and have them installed by a professional.
- Contact your dealer to move and reinstall the air conditioner or heat pump. Incomplete installation may result in water leakage, electric shock, and fire.
- Never let the indoor unit or the remote controller get wet. Water can cause an electric shock or a fire.
- Never use flammable spray such as hair spray, lacquer, or paint near the unit. Flammable spray may cause a fire.
- When a fuse blows out, never replace it with one of incorrect ampere ratings or different wires. Always replace any blown fuse with a fuse of the same specification.
- Never remove the fan guard of the unit. A fan rotating at high speed without the fan guard is very dangerous.
- Never inspect or service the unit by yourself. Contact a qualified service person to perform this work.
- Turn off all electrical power before doing any maintenance to avoid the risk of serious electric shock; never sprinkle or spill water or liquids on the unit.
- Do not touch the switch with wet fingers. Touching a switch with wet fingers can cause electric shock.
- Do not allow children to play on or around the unit to prevent injury.
- The heat exchanger fins are sharp enough to cut. To avoid injury wear gloves or cover the fins while working around them.
- Do not put a finger or other objects into the air inlet or air outlet. The fan is rotating at high speed and will cause injury.
- Check the unit foundation for damage on a continuous basis, especially if it has been in use for a long time. If left in a damaged condition the unit may fall and cause injury.
- Placing a flower vase or other containers with water or other liquids on the unit could cause a shock or fire if a spill occurs.
- Do not touch the air outlet or horizontal blades while the swing flap is in operation because fingers could get caught and injured.
- Never touch the internal parts of the controller. Do not remove the front panel because some parts inside are dangerous to touch. To check and adjust internal parts, contact your dealer.
- Do not use means to accelerate the defrosting process or to clean, other than those recommended by the manufacturer.
- The appliance must be stored in a room without continuously operating ignition sources (for example: open flames, an operating gas appliance or an operating electric heater).
- Do not pierce or burn.
- Be aware that refrigerants may not contain an odor.

Read Before Operation

⚠ CAUTION

- Do not use the air conditioner or heat pump for any other purposes other than comfort cooling or heating. Do not use the unit for cooling precision instruments, food, plants, animals or works of art.
- Do not place items under the indoor unit as they may be damaged by condensates that may form if the humidity is above 80% or if the drain outlet gets blocked.
- Before cleaning, stop the operation of the unit by turning the power off or by pulling the supply cord out from its receptacle. Otherwise, an electric shock and injury may result.
- Do not wash the air conditioner or heat pump with excessive water. An electric shock or fire may result.
- Avoid placing the controller in a spot which may be splashed with water. Water entering the controller may cause an electric shock or damage the internal electronic parts.
- Do not operate the air conditioner or heat pump when using a room-fumigation type of insecticide. Failure to observe this could cause the chemicals to be deposited in the unit and can endanger the health of those who are hypersensitive to chemicals.
- Do not turn off the power immediately after stopping operation. Always wait for at least 5 minutes before turning off the power. Otherwise, water leakage may occur.
- The appliance is not intended for use by young children or infirm persons without supervision.
- The remote controller should be kept away from children so they cannot play with it.
- Consult with the installation contractor for cleaning.
- Incorrect cleaning of the inside of the air conditioner or heat pump could make the plastics parts break and cause water leakage or electric shock.
- Do not touch the air inlet or aluminum fin of the air conditioner or heat pump as they can cut and cause injury.
- Do not place objects in direct proximity of the outdoor unit. Do not let leaves and other debris accumulate around the unit. Leaves are a hotbed for small animals which can enter the unit. Once inside the unit, animals can cause the unit to malfunction, and cause smoke or fire when they make contact with electrical parts.
- Do not wipe the controller operation panel with benzene, thinner, chemical dust cloth, etc. The panel may get discolored or the coating can peel off. If it is heavily dirty, soak a cloth in water-diluted neutral detergent, squeeze it well and wipe the panel clean. Then wipe it with another dry cloth.
- Dismantling of the unit, disposal of the refrigerant, oil, and additional parts, should be done in accordance with the relevant local, state, and national regulations.
- Operate the air conditioner or heat pump in a sufficiently ventilated area and not surrounded by obstacles. Do not use the air conditioner or heat pump in the following places.
 - a. Places with a mist of mineral oil, such as cutting oil.
 - b. Locations such as coastal areas where there is a lot of salt in the air.
 - c. Locations such as hot springs where there is a lot of sulfur in the air.
 - d. Locations such as factories where the power voltage varies a lot.
 - e. In cars, boats, and other vehicles.
 - f. Locations such as kitchens where oil may splatter or where there is steam in the air.
 - g. Locations where equipment produces electromagnetic waves.
 - h. Places with an acid or alkaline mist.
 - i. Places where fallen leaves can accumulate or where weeds can grow.
- Take snow protection measures. Contact your dealer for the details of snow protection measures, such as the use of a snow protection hood.
- Do not attempt to do electrical work or grounding work unless you are licensed to do so. Consult with your dealer for electrical work and grounding work.
- Pay attention to operating sound. Be sure to use the following places:
 - a. Places that can sufficiently withstand the weight of the air conditioner or heat pump yet can suppress the operating sound and vibration.
 - b. Places where warm air from the air outlet of the outdoor unit or the operating sound of the outdoor unit does not annoy neighbors.
- Make sure that there are no obstacles close to the outdoor unit. Obstacles close to the outdoor unit may drop the performance of the outdoor unit or increase the operating sound of the outdoor unit.
- Consult your dealer if the air conditioner or heat pump in operation generates unusual noise.
- Make sure that the drainpipe is installed properly to drain water. If no water is discharged from the drainpipe while the air conditioner or heat pump is in the cooling mode, the drainpipe may be clogged with dust or dirt and water leakage from the indoor unit may occur. Stop operating the air conditioner or heat pump and contact your dealer.
- Do not spray the air conditioner unit with any deodorizers, etc. It may cause the unit to malfunction.

⚠ NOTE

- Never press the button of the remote controller with a hard, pointed object. The remote controller may be damaged.
- Never pull or twist the electric wire of the remote controller. It may cause the unit to malfunction.
- Do not place appliances that produce open flames in places that are exposed to the airflow of the unit or under the indoor unit. It may cause incomplete combustion or deformation of the unit due to the heat.
- Do not expose the controller to direct sunlight. The LCD display can become discolored and may fail to display the data.

FTP002(R32)-U

Read Before Operation

Names of Parts

Indoor Unit

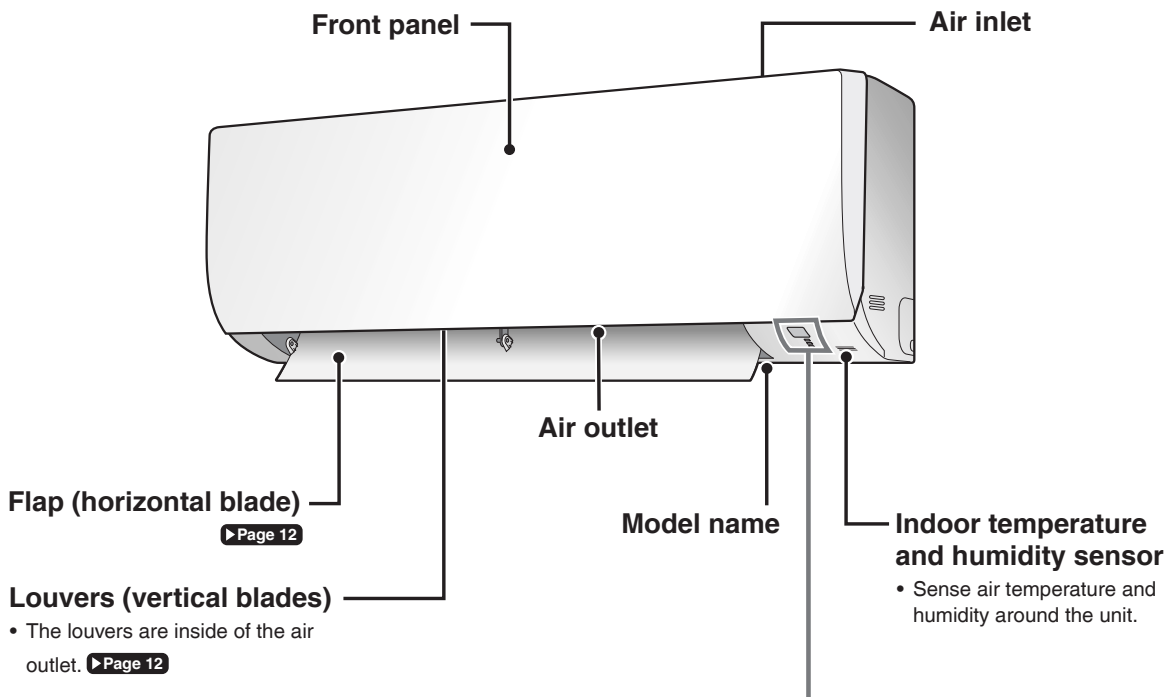

Display

Signal receiver

- Receives signals from the remote controller.
- When the unit receives a signal, you will hear a beep sound.

Case	Sound type
Operation start	beep-beep
Setting changed	beep
Operation stop	long beep

OPERATION lamp (Green)
 ▶ Page 9

TIMER lamp (Orange)
 ▶ Page 15, 16

Wireless LAN connection adapter lamp (Orange)
 • Only functional when a wireless LAN connection adapter (sold separately) is in use.

Indoor unit ON/OFF switch

- Press this switch once to start operation. Press once again to stop it.
- For the operation mode setting, refer to the following table.

Mode	Temperature setting	Airflow rate
AUTO	77°F (25°C)	AUTO

- This switch can be used when the remote controller is missing or out of batteries.

Read Before Operation

■ **Open the front panel**

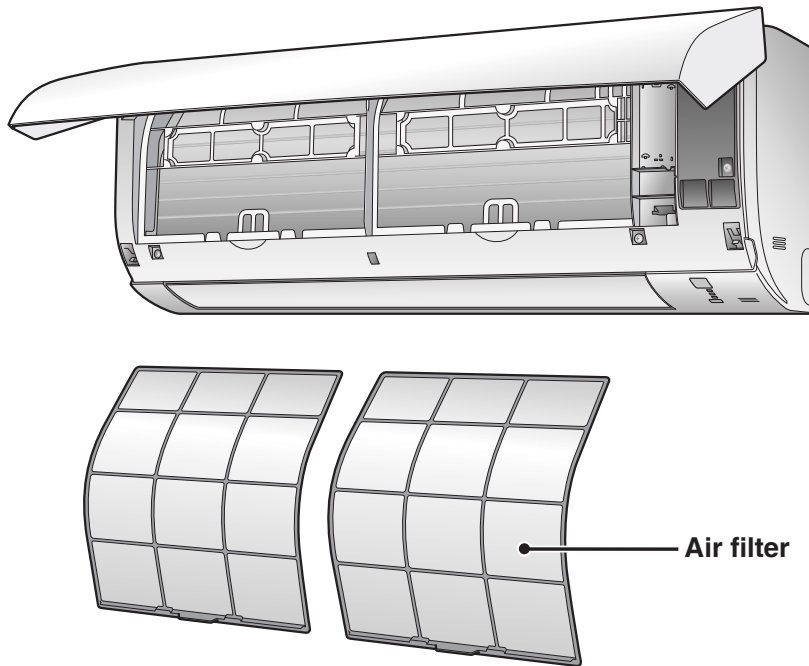

Outdoor Unit

• The appearance of the outdoor unit may differ between different models.

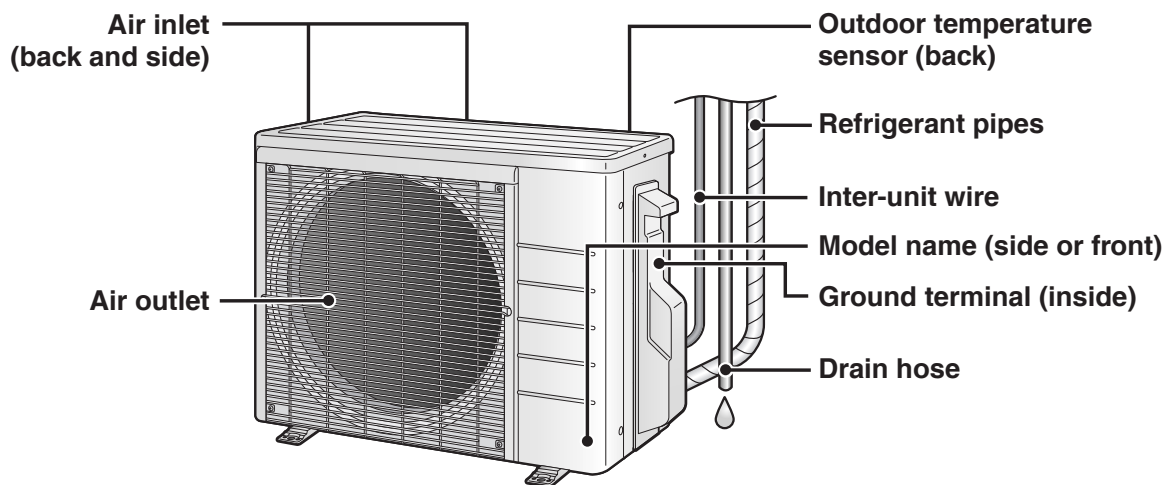

Read Before Operation

Names of Parts

Remote Controller

Display (LCD)

- Displays the current settings. (In this illustration, each section is shown with its displays on for the purpose of explanation.)

AUTO button

- Automatically selects an appropriate operation mode (COOL or HEAT) based on the indoor temperature and starts the operation. ▶Page 9

Direct operation buttons

- Starts the COOL, DRY, HEAT or FAN ONLY operation. ▶Page 9

TEMPERATURE adjustment button

- Changes the temperature setting. ▶Page 10

COMFORT button

- COMFORT AIRFLOW operation ▶Page 13

POWERFUL button

- POWERFUL operation ▶Page 13

OFF TIMER button (NIGHT SET mode)

- ▶Page 16

ON TIMER button

- ▶Page 15

Signal transmitter

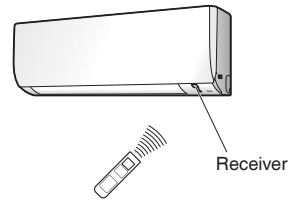

- To use the remote controller, aim the transmitter at the indoor unit. If there is anything blocking the signals between the unit and the remote controller, such as a curtain, the unit may not operate.
- The maximum transmission distance is about 23ft (7m).

OFF button

- Stops the operation. ▶Page 10

FAN setting button

- Selects the airflow rate setting. ▶Page 11

ECONO button

- ECONO operation ▶Page 14

SWING button

- Adjusts the airflow direction. ▶Page 12

TIMER CANCEL button

- Cancels the timer setting. ▶Page 16

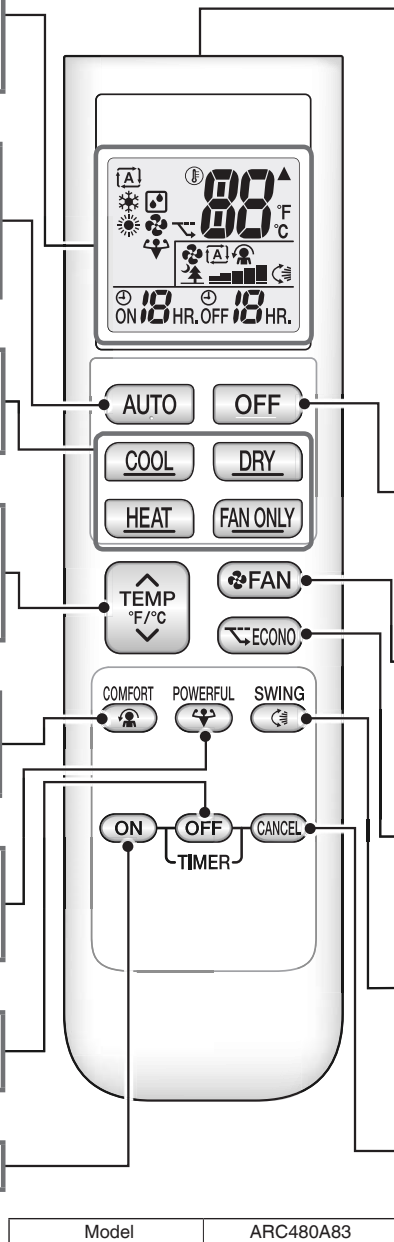

Model ARC480A83

Read Before Operation

Preparation Before Operation

CAUTION

Incorrect handling of batteries can result in injury from battery leakage, rupturing or heating, or lead to equipment failure. Please observe the following precautions and use safely.

- If the alkaline solution from the batteries should get in the eyes, do not rub the eyes. Instead, immediately flush the eyes with tap water and seek the attention of a medical professional.
- Keep batteries out of reach of children. In the event that batteries are swallowed, seek the immediate attention of a medical professional.
- Do not expose batteries to heat or fire. Do not disassemble or modify batteries. The insulation or gas release vent inside the battery may be damaged, resulting in battery leakage, rupturing, or heating.
- Do not damage or peel off labels on the batteries.

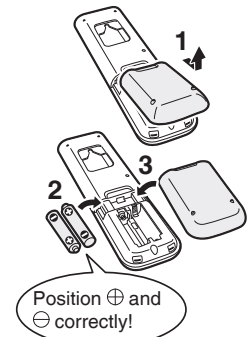

To insert the batteries

1. Remove the back cover by sliding and then slightly lifting it.
2. Insert 2 dry batteries AAA.LR03 (alkaline).
3. Replace the back cover.

To attach the remote controller holder to a wall

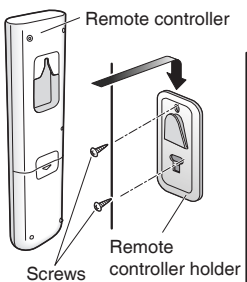

1. Choose a place where the signals reach the unit.
2. Attach the holder to a wall, a pillar, or similar location with the screws supplied with the holder.
3. Hang the remote controller on the remote controller holder.

Fahrenheit/Celsius display switch

Press  and  (TIMER button) simultaneously for about 5 seconds.

- The temperature will be displayed in Celsius when it is presently displayed in Fahrenheit, and vice versa.
- The switch operation is only possible when the temperature is being displayed.
- A reception sound will go off for the transmission of set temperature to the indoor unit at the time of setting the Fahrenheit/Celsius display change function.

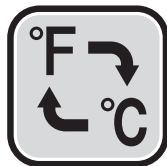

To attach the titanium apatite deodorizing filter (sold separately)

- If attaching the separately sold filters, attach them before turning the power on. [▶ Page 21](#)

Turn on the circuit breaker

- After the power is turned on, the flap of the indoor unit opens and closes once to set the reference position.

NOTE

Notes on batteries

- To avoid possible injury or damage from battery leakage or rupturing, remove the batteries when not using the product for long periods of time.
- The standard replacement time is about 1 year. Both batteries should be replaced at the same time. Be sure to replace them with new dry batteries AAA.LR03 (alkaline).
- If the remote controller display begins to fade and signal reception begins to decline, replace the batteries with new batteries. Owing to usage conditions, battery consumption may be accelerated.
- The batteries supplied with the remote controller are for initial operation. The batteries may run out in less than 1 year.

Notes on remote controller

- Do not drop the remote controller. Do not get it wet.
- If dirt becomes an issue, wipe with a soft dry cloth.

Fahrenheit/Celsius display change function of remote controller

- The set temperature may increase when the display is changed to Celsius from Fahrenheit, because a fraction of 0.5°C is rounded up.
- Example: A set temperature of 65°F (equivalent to 18.5°C) will be converted into 19°C.

When the display is changed to Fahrenheit again, the set temperature will be converted into 66°F (equivalent to 19°C) instead of the original set temperature (65°F) but a set temperature of 66°F (equivalent to 19°C) will be converted into 19°C with no temperature change.

Basic Operation



AUTO · COOL · DRY · HEAT · FAN ONLY Operation



The air conditioner operates with the operation mode of your choice.

To start operation

AUTO operation

- To automatically select an appropriate temperature and operation mode.

Press **AUTO** .



COOL operation

- To lower the temperature.

Press **COOL** .



DRY operation

- To lower the humidity.

Press **DRY** .



HEAT operation

- To raise the temperature.

Press **HEAT** .



FAN ONLY operation

- To circulate air in the room.

Press **FAN ONLY** .



- The OPERATION lamp lights green.

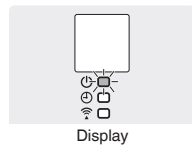

NOTE

Notes on AUTO operation

- In AUTO operation, the system selects an appropriate operation mode (COOL or HEAT) based on the indoor temperature and starts the operation.
- The system automatically reselects setting at a regular interval to bring the indoor temperature to the user-setting level.

Note on DRY operation

- Eliminates humidity while maintaining the indoor temperature as much as possible. It automatically controls temperature and airflow rate, so manual adjustment of these functions is unavailable.

Basic Operation

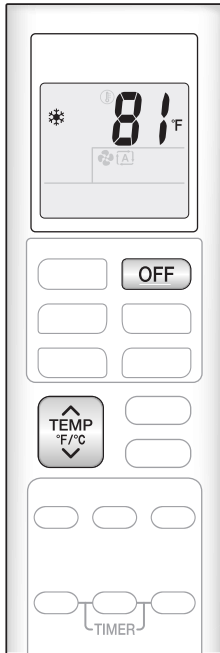

To stop operation

Press **OFF** .

- The OPERATION lamp goes off.

To change the temperature setting

Press **TEMP °F/°C** .

- Press **▲** to raise the temperature and press **▼** to lower the temperature.

COOL operation	HEAT operation	AUTO operation	DRY or FAN ONLY operation
64-90°F (18-32°C)	50-86°F (10-30°C)	64-86°F (18-30°C)	The temperature setting cannot be changed.

Tips for saving energy

Keeping the temperature setting at a moderate level helps save energy.

- Recommended temperature setting
 - For cooling: 78-82°F (26-28°C)
 - For heating: 68-75°F (20-24°C)

Cover windows with a blind or a curtain.

- Blocking sunlight and air from outdoors increases the cooling (heating) effect.

Keep the air filters clean.

- Clogged air filters cause inefficient operation and waste energy. Clean them once in about every 2 weeks. [▶Page 20](#)

If you are not going to use the air conditioner for a long period, for example in spring or autumn, turn off the circuit breaker.

- The air conditioner always consumes a small amount of electricity even while it is not operating.



Basic Operation



Adjusting the Airflow Rate

You can adjust the airflow rate to increase your comfort.

To adjust the airflow rate setting

Press **FAN**.

- Each pressing of **FAN** changes the airflow rate setting in sequence.



- When the airflow is set to “”, quiet operation starts and noise from the indoor unit will become quieter. However, it may become difficult to cool (or warm) the room.
- In the quiet operation mode, the airflow rate is set to a weak level.



AUTO, COOL, HEAT and FAN ONLY operation	DRY operation
	The airflow rate setting cannot be changed. (only AUTO)

NOTE

Note on airflow rate setting

- At smaller airflow rates, the cooling (heating) effect is also smaller.

Note on AUTO airflow rate

- When using AUTO airflow rate, the airflow rate is adjusted according to conditions in the room.



Adjusting the Airflow Direction

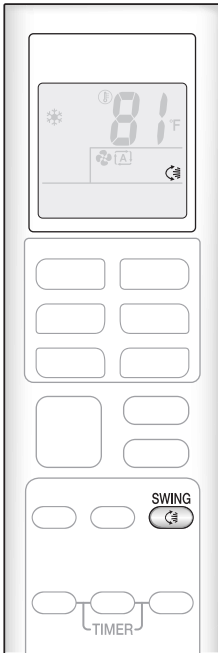

You can adjust the airflow direction to increase your comfort.

⚠ CAUTION

- Always use a remote controller to adjust the angles of the flap. Moving the flap forcibly by hand may cause a malfunction.
- Be careful when adjusting the louvers. Inside the air outlet, a fan is rotating at a high speed.

To start auto swing

Up and down airflow direction

Press  .

- “” is displayed on the LCD.
- The flap (horizontal blade) will begin to swing.

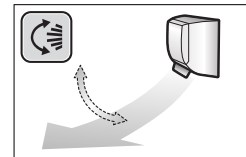

To set the flap at the desired position

- This function is effective while the flap is in auto swing mode.

Press  when the flap reaches the desired position.

- “” disappears from the LCD.

To adjust the louvers at desired position

Hold the knobs and move the louvers (vertical blades).

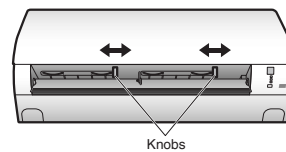

NOTE

Notes on airflow direction setting

- The movable range of the flap varies according to the operation mode.
 - If the airflow rate becomes weak during operation, the flap will stop.
- When up and down airflow direction is set, the flap will stop in an upward position.

Movable range of the flap

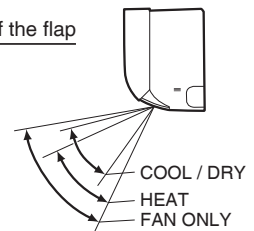

Useful Functions



COMFORT AIRFLOW Operation

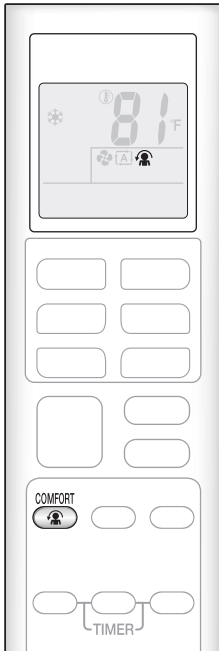

The flow of air will be in the upward direction while in COOL and DRY operation and in the downward direction while in HEAT operation, which will provide a comfortable airflow that will not come in direct contact with people.

To start COMFORT AIRFLOW operation

Press  .

- “” is displayed on the LCD.

	COOL and DRY operation	HEAT operation	FAN operation
Flap direction	Goes up	Goes down	Not available
Airflow rate	AUTO		

- When in AUTO operation, the flap direction differs based on the operation mode (COOL or HEAT) as shown in the table above.

To cancel COMFORT AIRFLOW operation

Press  again.

- “” disappears from the LCD.
- The flap will return to the memory position from before COMFORT AIRFLOW operation.



POWERFUL Operation



POWERFUL operation quickly maximizes the cooling (heating) effect in any operation mode. In this mode, the air conditioner operates at maximum capacity.

To start POWERFUL operation

Press  .

- “” is displayed on the LCD.
- POWERFUL operation ends in 20 minutes. Then the system automatically operates again with the previous settings which were used before POWERFUL operation.

To cancel POWERFUL operation

Press  again.

- “” disappears from the LCD.

Useful Functions



ECONO Operation



ECONO operation enables efficient operation by limiting the maximum power consumption. This function is useful to prevent the circuit breaker from tripping when the unit operates alongside other appliances on the same circuit.

To start ECONO operation

- Press .
- “” is displayed on the LCD.
- Not available in FAN ONLY mode.

To cancel ECONO operation

- Press again.
- “” disappears from the LCD.

NOTE

Notes on COMFORT AIRFLOW operation

- The airflow rate will be set to AUTO.
- If the up and down airflow direction is selected, the COMFORT AIRFLOW operation will be canceled.

Notes on POWERFUL operation

- Pressing causes the settings to be canceled, and “” disappears from the LCD.
- POWERFUL operation will not increase the capacity of the air conditioner if the air conditioner is already in operation with its maximum capacity demonstrated.

- In COOL, HEAT and AUTO operation

To maximize the cooling (heating) effect, the capacity of outdoor unit increases and the airflow rate becomes fixed at the maximum setting. The temperature and airflow settings cannot be changed in COOL and HEAT operation. Airflow settings cannot be changed in AUTO operation.

- In DRY operation

The temperature setting is lowered by 1.8°F (1.0°C) and the airflow rate is slightly increased.

- In FAN ONLY operation

The airflow rate is fixed at the maximum setting.

Notes on ECONO operation

- This operation is performed with lower power and therefore may not provide a sufficient cooling (heating) effect.
- Pressing causes the settings to be canceled, and “” disappears from the LCD.
- If the power consumption level is already low, switching to ECONO operation will not reduce the power consumption.

Some useful functions can be used together.

COMFORT AIRFLOW + ECONO	Available
POWERFUL + COMFORT AIRFLOW	Not available*
POWERFUL + ECONO	Not available*

*Priority is given to the function of whichever button is pressed last.

TIMER Operation



ON/OFF TIMER Operation

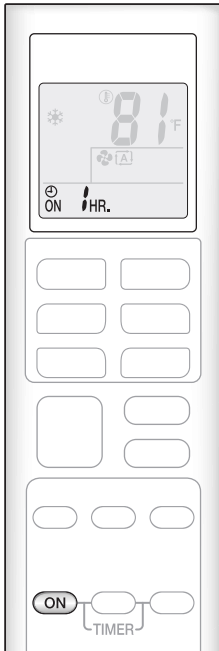

Timer functions are useful for automatically switching the air conditioner on or off in the morning or at night. You can also use the ON TIMER and OFF TIMER together.

To use ON TIMER operation

Press **ON** .

- Each pressing of **ON** changes the time setting by 1 hour. The time can be set between 1 and 12 hours.
- The TIMER lamp lights orange.

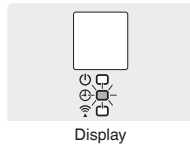

Display

NOTE

In the following cases, set the timer again.

- After the circuit breaker has turned off.
- After a power failure.
- After replacing the batteries in the remote controller.

TIMER Operation

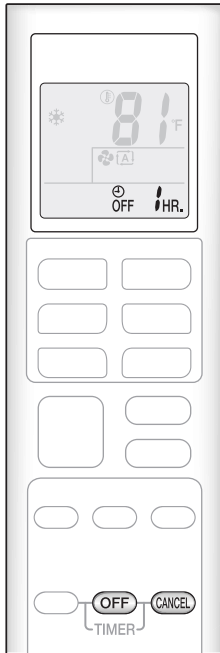

To use OFF TIMER operation

Press **OFF**.

- Each pressing of **OFF** changes the time setting by 1 hour. The time can be set between 1 and 12 hours.
- The TIMER lamp lights orange.

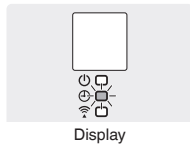

To cancel ON/OFF TIMER operation

Press **CANCEL**.

To combine ON TIMER and OFF TIMER operation

- A sample setting for combining the 2 timers is shown below.
- "ON" and "OFF" are displayed on the LCD.

[Example]

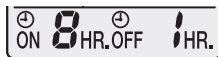

When setting while the unit is operating

- Stops the unit 1 hour later and starts it 7 hours after that.



When setting while the unit is stopped

- Starts the unit 2 hours later and stops it 3 hours after that.

NOTE

NIGHT SET mode

- When the OFF TIMER is set, the air conditioner automatically adjusts the temperature setting (0.9°F (0.5°C) up in COOL, 3.6°F (2.0°C) down in HEAT) to prevent excessive cooling (heating) during sleeping hours.

Making Changes to Default Settings

Brightness of Indoor Unit LED Lamps

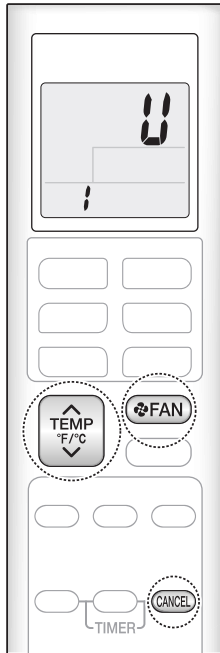

Changes can be made to the setting for the brightness of the LED lamps, to suit your preferences.

1. While operation is stopped, press **FAN** and hold the button for 5 seconds.

2. Press **TEMP F/C** and select menu number **1**.

- “1” appears on the LCD.
- “1” blinks.

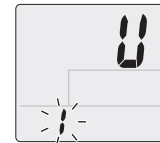

3. Press **FAN**.

4. Press **TEMP F/C** or **TEMP F/C** and select setting option.

- The setting option will blink.

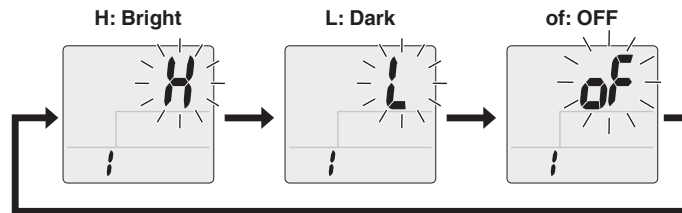

5. Press **FAN**.

6. Press **FAN** and hold the button for 5 seconds to return to the default screen.

NOTE

- Press **CANCEL** to return to the previous screen.
- If no operations are performed for approximately 1 minute, the display will return to the default screen.
- Indoor unit default setting: H (Bright)

Making Changes to Default Settings

Airflow Setting When Indoor Unit Reaches Setpoint

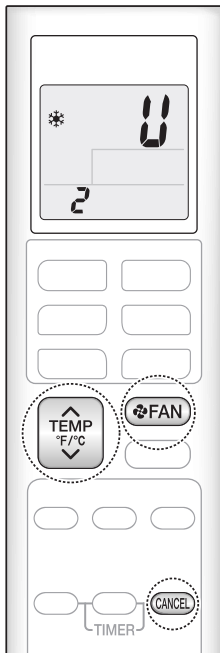

Changes can be made to the setting for airflow rate when unit reaches desired temperature (setpoint), to suit your preferences. This function is effective when COOL operation is selected.

1. While operation is stopped, press and hold the button for 5 seconds.

2. Press or and select menu number 2.

- “U” appears on the LCD.
- “2” blinks.



3. Press .

4. Press or and select setting option.

- The setting option will blink.

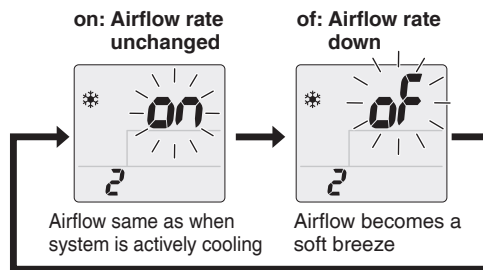

5. Press .

6. Press and hold the button for 5 seconds to return to the default screen.

NOTE

- Press to return to the previous screen.
- If no operations are performed for approximately 1 minute, the display will return to the default screen.
- Indoor unit default setting: of (Airflow rate down)

Care

Care and Cleaning

⚠ CAUTION

- Before cleaning, be sure to stop the operation and turn off the circuit breaker.
- Do not touch the aluminum fins of the indoor unit. If you touch those parts, this may cause an injury.

■ Quick reference

Cleaning parts

Front panel

- Wipe with a soft cloth which has been moistened with water or neutral detergent.
- Only neutral detergent may be used.

If dirty

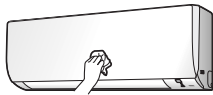

Air filter

- Vacuum dust or wash the filter.

Once every 2 weeks

▶ Page 20

Indoor unit, outdoor unit and remote controller

- Wipe them with a soft cloth.

If dirty

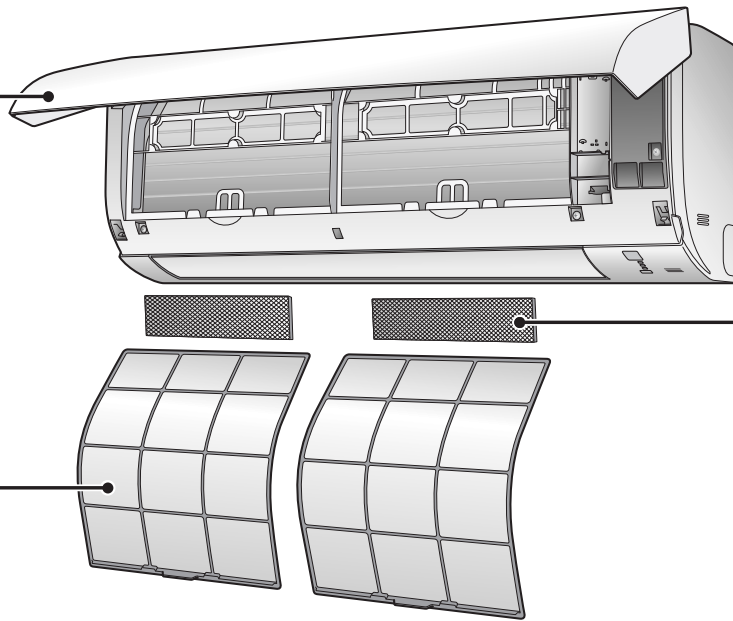

Titanium apatite deodorizing filter (sold separately)

Titanium apatite deodorizing filters are sold separately (not included with the air conditioner). To purchase, contact the dealer where you bought the air conditioner.

Item	Part No.
Titanium apatite deodorizing filter 1 set (2 pieces)	KAF970A46 (without frame)

- Vacuum dust or replace the filter.

[Cleaning]

Once every 6 months

▶ Page 21

[Replacement]

Once every 3 years

▶ Page 21

NOTE

For cleaning, do not use any of the following:

- Water hotter than 104°F (40°C)
- Volatile liquid such as benzene, gasoline and thinner
- Polishing compounds
- Rough materials such as a scrubbing brush
- Sprays such as deodorizers



Care

■ Air filter

1. Open the front panel.

- Hold the front panel by the sides and open it.

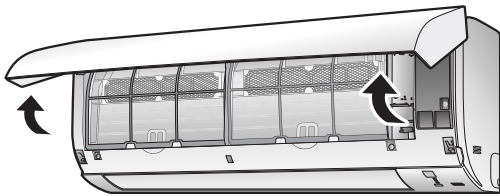

2. Pull out the air filters.

- Push the filter tab at the center of each air filter a little upwards, then pull it down.

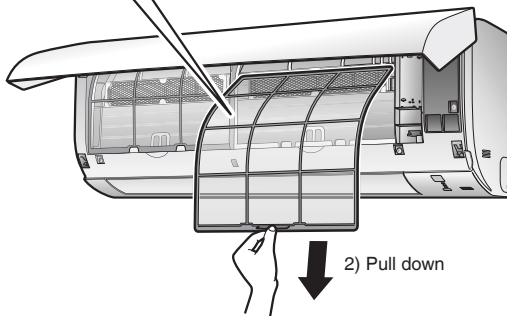
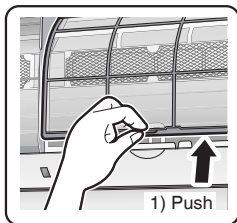

3. Wash the air filters with water or clean them with vacuum cleaner.

- It is recommended to clean the air filters every 2 weeks.

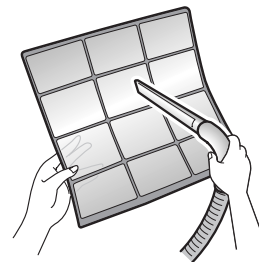

If the dust does not come off easily

- Wash the air filters with neutral detergent thinned with lukewarm water, then dry them up in the shade.

4. Reattach the filters.

5. Close the front panel slowly.

- Press the panel at both sides and the center.

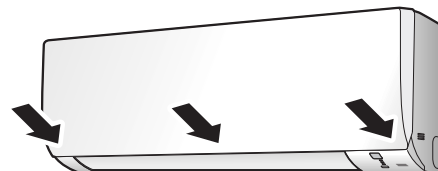

- Make sure that the front panel is securely fixed.

Care

Care and Cleaning

■ Titanium apatite deodorizing filter (sold separately)

1. Open the front panel and pull out the air filters. ▶Page 20

2. Take off the titanium apatite deodorizing filters.

- Remove the filters from the tabs.

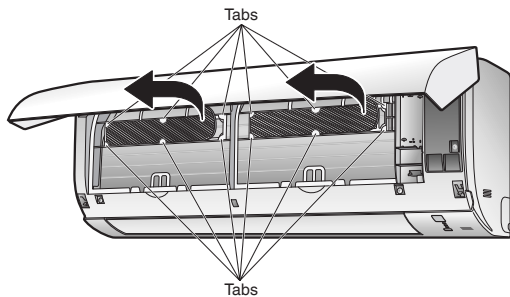

3. Clean or replace the titanium apatite deodorizing filters.

[Cleaning]

3-1 Vacuum dust, and soak in lukewarm water or water for about 10 to 15 minutes if very dirty.

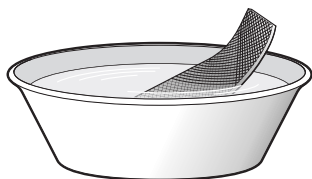

3-2 After washing, shake off remaining water and let them dry in the shade.

- Do not wring out the filter to remove water from it.

[Replacement]

Remove the filter from the tabs and prepare a new one.

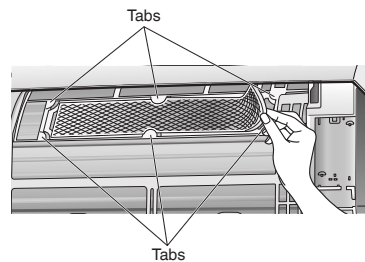

- Dispose of the old filter as non-flammable waste.

4. Insert the titanium apatite deodorizing filters as they were.

- When attaching the filter, check that the filter is properly set in the tabs.
- The titanium apatite deodorizing filter can be attached in any orientation.

5. Reattach the filters. ▶Page 20

6. Close the front panel slowly.

▶Page 20

NOTE

- Operation with dirty filters:
 - cannot deodorize the air,
 - cannot clean the air,
 - results in poor heating or cooling,
 - may cause odor.
- Dispose of old filters as non-flammable waste.

■ Prior to a long period of non-use

1. Operate the FAN ONLY mode for several hours on a mild day to dry out the inside.

- Press **FAN ONLY**.

2. After operation stops, turn off the circuit breaker for the room air conditioner.

3. Clean the air filters and reattach them. [▶ Page 20](#)

4. To prevent battery leakage, take out the batteries from the remote controller.

- When starting to use the air conditioner again, make sure that the drain hose outlet is not blocked, then turn on the circuit breaker.
An operational check of each component will be carried out automatically. (Also, put the batteries into the remote controller.)

■ We recommend periodical maintenance

- In certain operating conditions, the inside of the air conditioner may get foul after several seasons of use, resulting in poor performance. It is recommended to have periodical maintenance by a qualified contractor in addition to regular cleaning by the user.
- For qualified contractor maintenance, please contact the dealer where you bought the air conditioner.

When the Need Arises

FAQ

Indoor unit

The flap does not start swinging immediately.

- The air conditioner is adjusting the position of the flap. The flap will start moving soon.

The air conditioner stops generating airflow during HEAT operation.

- Once the set temperature is reached, the airflow rate is reduced and operation stopped in order to avoid generating a cool airflow. Operation will resume automatically when the indoor temperature falls.

HEAT operation stops suddenly and a flowing sound is heard.

- The outdoor unit is defrosting. HEAT operation starts after the frost on the outdoor unit has been removed. This can take about 4 to 12 minutes.

Operation does not start soon.

- **When the unit is turned on again soon after being turned off.**
- **When the mode was reselected.**
 - This is to protect the air conditioner. You should wait for about 3 minutes.

Different sounds are heard.

- **A sound like flowing water**
 - This sound is generated because the refrigerant in the air conditioner is flowing.
 - This is a pumping sound of the water in the air conditioner and can be heard when the water is pumped out from the air conditioner during COOL or DRY operation.
 - The refrigerant flows in the air conditioner even if the air conditioner is not working when the indoor units in other rooms are in operation.
- **Blowing sound**
 - This sound is generated when the flow of the refrigerant in the air conditioner is switched over.
 - If the outdoor temperature is low, this sound is generated when the direction of the flow of the refrigerant in the piping changes at the start of defrost operation, after HEAT operation is stopped and the room temperature is stabilized.
- **Ticking sound**
 - This sound is generated when the cabinet and frame of the air conditioner slightly expand or shrink as a result of temperature changes.
- **Whistling sound**
 - This sound is generated when refrigerant flows during defrosting operation.
- **Clicking sound during operation or idle time**
 - This sound is generated when the refrigerant control valves or the electrical parts operate.
- **Clopping sound**
 - This sound is heard from the inside of the air conditioner when the exhaust fan is activated while the room doors are closed. Open the window or turn off the exhaust fan.

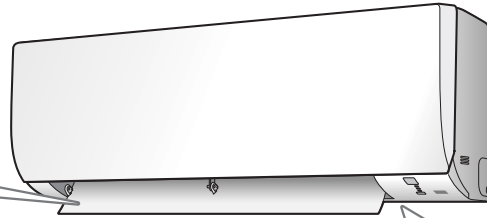

Outdoor unit

Operating sound is loud.

- When frost forms on the heat exchanger of the outdoor unit, the operating sound level increases slightly.

The outdoor unit emits water or steam.

- **In HEAT operation**
 - The frost on the outdoor unit melts into water or steam when the air conditioner is in defrosting operation.
- **In COOL or DRY operation**
 - Moisture in the air condenses into water on the cool surface of the outdoor unit piping and drips.

Blowing sound

- If the outdoor temperature is low, this sound is generated when the direction of the flow of the refrigerant in the piping changes at the start of defrost operation, after HEAT operation is stopped and the room temperature is stabilized.

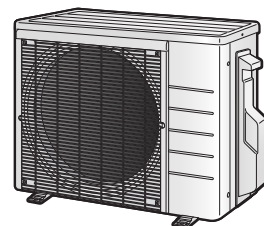

When the Need Arises

Troubleshooting

Before making an inquiry or a request for repair, please check the following.
If the problem persists, consult your dealer.



Not a problem

This case is not a problem.



Check

Please check again before requesting repairs.

The air conditioner does not operate

Case	Description / what to check
OPERATION lamp is off.	<ul style="list-style-type: none"> Has the circuit breaker been tripped or the fuse blown? Is there a power failure? Are batteries set in the remote controller?
OPERATION lamp is blinking.	<ul style="list-style-type: none"> Turn off the power with the circuit breaker and restart operation with the remote controller. If the OPERATION lamp is still blinking, check the error code and consult your dealer. ▶ Page 27, 28

The air conditioner suddenly stops operating

Case	Description / what to check
OPERATION lamp is on.	<ul style="list-style-type: none"> To protect the system, the air conditioner may stop operating after sudden large voltage fluctuations. It automatically resumes operation in about 3 minutes.
OPERATION lamp is blinking.	<ul style="list-style-type: none"> Are the air filters dirty? Clean the air filters. Is there anything blocking the air inlet or air outlet of the indoor unit or outdoor unit? Stop operation and after turning off the circuit breaker, remove the obstruction. Then restart operation with the remote controller. If the OPERATION lamp is still blinking, check the error code and consult your dealer. ▶ Page 27, 28

The air conditioner does not stop operating

Case	Description / what to check
The air conditioner continues operating even after operation is stopped.	<ul style="list-style-type: none"> Immediately after the air conditioner is stopped <ul style="list-style-type: none"> The outdoor unit fan continues rotating for about another 1 minute to protect the system. While the air conditioner is not in operation <ul style="list-style-type: none"> When the outdoor temperature is high, the outdoor unit fan may start rotating to protect the system.

When the Need Arises

Troubleshooting

The room does not cool down / warm up

Case	Description / what to check
Air does not come out.	<ul style="list-style-type: none"> <input checked="" type="checkbox"/> ■ In HEAT operation <ul style="list-style-type: none"> • The air conditioner is warming up. Wait for about 1 to 4 minutes. • During defrosting operation, hot air does not flow out of the indoor unit. ■ When the air conditioner operates immediately after the circuit breaker is turned on <ul style="list-style-type: none"> • The air conditioner is preparing to operate. Wait for about 3 to 10 minutes. • When the outdoor temperature is below 40°F (5°C) and heating operation is started, the air conditioner is warming up. Wait for about 10 to 25 minutes.
Air does not come out / Air comes out.	<ul style="list-style-type: none"> <input type="checkbox"/> ■ Is the airflow rate setting appropriate? <ul style="list-style-type: none"> • Is the airflow rate setting low, such as “Indoor unit quiet” or “Airflow rate 1”? Increase the airflow rate setting. ■ Is the set temperature appropriate? ■ Is the adjustment of the airflow direction appropriate?
Air comes out.	<ul style="list-style-type: none"> <input type="checkbox"/> • Is there any furniture directly under or beside the indoor unit? • Is the air conditioner in ECONO operation? ▶ Page 14 • Are the air filters dirty? • Is there anything blocking the air inlet or air outlet of the indoor unit or outdoor unit? • Is a window or door open? • Is an exhaust fan turning? • Depending on the room conditions, number of occupants, or outdoor temperature and humidity, the set temperature may not be reached. <p>A temperature regulation function which factors in living space conditions is available. For further details, please contact your dealer.</p>

Water or mist comes out

Case	Description / what to check
Mist comes out of the indoor unit.	<ul style="list-style-type: none"> <input checked="" type="checkbox"/> • This happens when the air in the room is cooled into mist by the cold airflow during COOL or other operation.
Water is leaking from the indoor unit.	<ul style="list-style-type: none"> <input type="checkbox"/> • If the drain hose is crushed or clogged, water from the indoor unit may be unable to drain and start leaking. Stop operation of the unit immediately and contact your dealer.

Remote controller

Case	Description / what to check
The unit does not receive signals from the remote controller or has a limited operating range.	<ul style="list-style-type: none"> <input checked="" type="checkbox"/> • The batteries may be exhausted. Replace both batteries with new dry batteries AAA.LR03 (alkaline). For details, refer to “Preparation Before Operation”. ▶ Page 8 • Signal communication may be disabled if an electronic-starter-type fluorescent lamp (such as inverter-type lamps) is in the room. Consult your dealer if that is the case. • The remote controller may not function correctly if the transmitter is exposed to direct sunlight. • Is there a device in the room that redirects remote controller signals? Some appliances such as TV speakers are equipped with these devices. If there is such a device in the room, the signals it emits may interfere with signals from the remote controller, preventing reception. • Infrared rays from smartphones and game consoles may interfere with signals from the remote controller, preventing reception.
LCD is faint, is not working, or the display is erratic.	<ul style="list-style-type: none"> <input checked="" type="checkbox"/> • The batteries may be exhausted. Replace both batteries with new dry batteries AAA.LR03 (alkaline). For details, refer to “Preparation Before Operation”. ▶ Page 8
The LCD is blinking and the remote controller cannot be operated.	<ul style="list-style-type: none"> <input checked="" type="checkbox"/> • Battery power has run out. Replace both batteries at the same time with new size AAA.LR03 (alkaline) batteries. Leaving exhausted batteries in the remote controller can result in injury due to battery leakage, rupturing or heating, or lead to equipment failure. (Even when the LCD is blinking, the OFF button remains functional.)
Other electric devices start operating.	<ul style="list-style-type: none"> <input checked="" type="checkbox"/> • If the remote controller activates other electric devices, move them away or consult your dealer.

When the Need Arises

Air has an odor

Case	Description / what to check
The air conditioner gives off an odor.	<input checked="" type="checkbox"/> • The room odor absorbed in the unit is discharged with the airflow. We recommend you to have the indoor unit cleaned. Please consult your dealer.
	<input checked="" type="checkbox"/> • The indoor unit is blowing out room odor it has absorbed (the smell of walls or carpeting, furniture, clothes, and so on). If the air conditioner has been used for a long time, there is a chance that a dirty heat exchanger or fan are emitting an odor. We recommend you to have the indoor unit cleaned. Please consult your dealer. Do not spray the air conditioner unit with any deodorizers.

Display lamp

Case	Description / what to check
The unit operates even though the OPERATION lamp is off.	<input type="checkbox"/> • Is lamp brightness set to “OFF”? ▶Page 17
The LED lamps on the unit are dim.	<input type="checkbox"/> • Is lamp brightness set to “L”? ▶Page 17

Others

Case	Description / what to check
The air conditioner suddenly starts behaving strangely during operation.	<input type="checkbox"/> • The air conditioner may malfunction due to lightning or radio. If the air conditioner malfunctions, turn off the power with the circuit breaker and restart the operation with the remote controller.
The ceiling and walls around the indoor unit are black and dirty.	<input checked="" type="checkbox"/> • Due to the circulation pattern of the air and static electricity, the air conditioner is causing airborne dirt and dust to stick to walls and other surfaces. Depending on the wallpaper type, dirt may adhere more easily. A thorough cleaning of the area around the air conditioner is recommended.

Notes on the operating conditions

- If operation continues under any conditions other than those listed in the table,
 - A safety device may activate to stop the operation.
 - Dew may form on the indoor unit and drip from it when COOL or DRY operation is selected.
- *1 Cutting the jumper on the outdoor unit PCB will extend the cooling operation range to 14°F (–10°C).
Installing an air direction adjustment grille (sold separately) will further extend the operation range to –4°F (–20°C).
Please consult your dealer.

Mode	Operating conditions
COOL / DRY	Outdoor temperature : 50*1 - 115°F (10*1 - 46°C) *1 –4°F (–20°C) if an air direction adjustment grille (sold separately) is installed.
	Indoor temperature : 64 - 90°F (18 - 32°C) Indoor humidity : 80% max.
HEAT	Outdoor temperature : 5 - 75°F (–15 - 24°C) Indoor temperature : 50 - 86°F (10 - 30°C)

When the Need Arises

Troubleshooting

The OPERATION lamp blinks

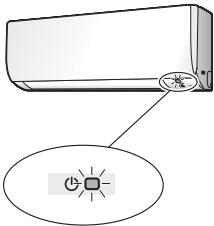

■ Check the interval time between blinks of the OPERATION lamp.

[Blink interval of about 0.5 seconds]
 This is a notification of an abnormality.
 Check the error code following the procedure below, and respond according to the instructions in the table.



■ Fault diagnosis by remote controller

1. When **CANCEL** is held down for about 5 seconds, “00” blinks in the temperature display section.
2. While pointing the remote controller at the indoor unit, press **CANCEL** repeatedly.
 A beep indicates a non-corresponding error code.
 A long beep indicates a corresponding error code.
3. When a long beep is produced, check the error code and respond according to the instructions in the table.
 - To cancel the code display, hold down **CANCEL** for about 5 seconds (the code display also clears if no button is pressed for a while).

CODE	Cause	Description / what to check
E7	The fan of the outdoor unit is stopped. • Is there any foreign matter inside the outdoor unit?	After turning off the circuit breaker, remove the foreign matter, then turn the power on again and operate.
L3, L4, L5	The temperature inside the outdoor unit has become too high, so operation has stopped. • Is there anything blocking the air outlet of the outdoor unit?	After turning off the circuit breaker, remove the obstruction, then turn the power on again and operate.
Other error codes, or if the error code cannot be checked		An abnormality has occurred.

In the case of error code U0 or F3

When the Need Arises

	CODE	MEANING
SYSTEM	00	NORMAL
	UA	INDOOR-OUTDOOR UNIT COMBINATION FAULT
	U0	REFRIGERANT SHORTAGE
	U2	DROP VOLTAGE OR MAIN CIRCUIT OVERVOLTAGE
	U4	FAILURE OF TRANSMISSION (BETWEEN INDOOR UNIT AND OUTDOOR UNIT)
INDOOR UNIT	A1	INDOOR PCB DEFECTIVENESS
	A5	HIGH PRESSURE CONTROL OR FREEZE-UP PROTECTOR
	A6	FAN MOTOR FAULT
	C4	FAULTY HEAT EXCHANGER TEMPERATURE SENSOR
	C9	FAULTY SUCTION AIR TEMPERATURE SENSOR
OUTDOOR UNIT	CC	FAULTY HUMIDITY SENSOR
	EA	COOLING-HEATING SWITCHING ERROR
	E1	CIRCUIT BOARD FAULT, ELECTRONIC EXPANSION VALVE COIL DRIVER FAULT
	E5	OL (COMPRESSOR OVERLOAD) STARTED, HIGH PRESSURE SWITCH (HPS) ACTIVATED*
	E6	FAULTY COMPRESSOR START UP
	E7	DC FAN MOTOR FAULT
	E8	OVERCURRENT INPUT
	E9	ELECTRONIC EXPANSION VALVE COIL FAULT
	F3	HIGH TEMPERATURE DISCHARGE PIPE CONTROL
	F6	HIGH PRESSURE CONTROL (IN COOLING)
	F8	OPERATION HALT DUE TO COMPRESSOR INTERNAL TEMPERATURE ABNORMALITY
	H0	SENSOR FAULT
	H6	OPERATION HALT DUE TO FAULTY POSITION DETECTION SENSOR
	H7	FAN IPM TEMPERATURE ERROR
	H8	DC CURRENT SENSOR FAULT
	H9	FAULTY SUCTION AIR TEMPERATURE SENSOR
	J3	FAULTY DISCHARGE PIPE TEMPERATURE SENSOR
	J6	FAULTY HEAT EXCHANGER TEMPERATURE SENSOR
	L3	ELECTRICAL PARTS HEAT FAULT
	L4	HIGH TEMPERATURE AT INVERTER CIRCUIT HEATSINK
L5	OUTPUT OVERCURRENT	
P4	FAULTY INVERTER CIRCUIT HEATSINK TEMPERATURE SENSOR	

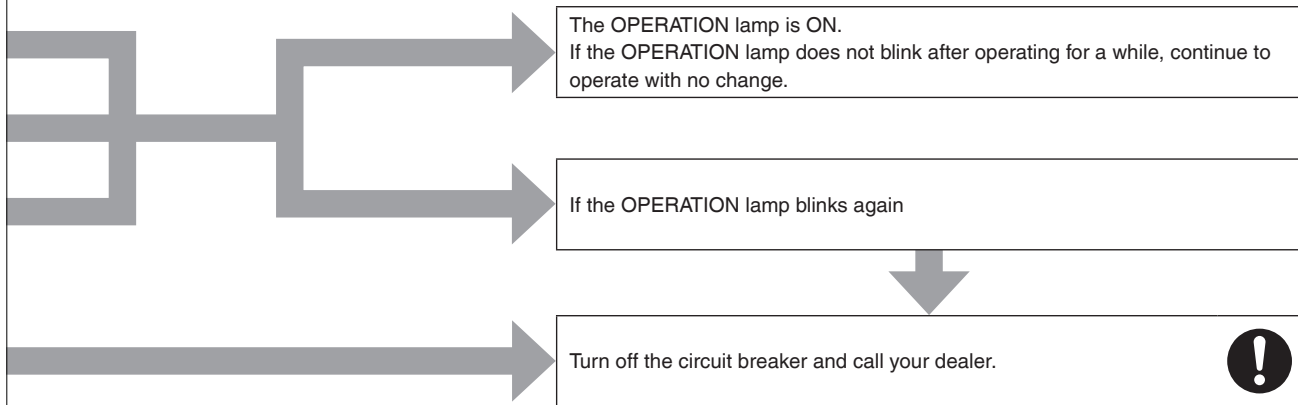

13. Options

13.1 Option List

13.1.1 Indoor Unit

Option Name		Model Name
Wired remote controller ★1		BRC944B2, BRC073A6
Wired remote controller cord (shielded wire)	Length 9.8 ft (3 m)	BRCW901A03
	Length 26.3 ft (8 m)	BRCW901A08
Wiring adaptor for timer clock / remote controller ★2 (normal open pulse contact / normal open contact)		KRP413BB1S
Central remote controller ★3		DCS302C71
Unified ON/OFF controller ★3		DCS301C71
Schedule timer controller ★3		DST301BA61
Interface adaptor for DIII-NET (residential air conditioner)		KRP928BB2S
Titanium apatite deodorizing filter (without frame)		KAF970A46
Remote controller loss prevention with chain		KKF936A4
Wireless LAN connection		BRP084A61

★1 A wired remote controller cord BRCW901A03 or BRCW901A08 is necessary.

★2 Timer clock and other devices; obtained locally.

★3 An interface adaptor (KRP067A41) is also required for each indoor unit.

13.1.2 Outdoor Unit

Option Name	Model
Air direction adjustment grille	KPW937F4
Back protection wire net	KKG067A41
Drain plug	KKP937A4
Snow hood (intake side plate)	KPS067A41
Snow hood (intake rear plate)	KPS067A42
Snow hood (outlet)	KPS067A44

13.2 <BRC073A6> Wired Remote Controller (Installation)

Safety Considerations



1. Safety Considerations

The original instructions are written in English. All other languages are translations of the original instructions.

■ Also see the installation manual attached to the indoor unit.

Please read these Safety Considerations carefully before installing the user interface.

- This manual classifies the precautions into WARNING and CAUTION. They both contain important information regarding safety. Be sure to follow all the precautions below.

 WARNING	Failure to follow these instructions properly may result in personal injury or loss of life.
 CAUTION	Failure to observe these instructions properly may result in property damage or personal injury, which may be serious depending on the circumstances.

- After completing the installation, conduct a trial operation to check for faults and explain to the customer how to operate the air conditioner with the aid of the User reference guide. Ask the customer to store the Installer reference guide along with the User reference guide for future reference.

Safety Considerations

 **WARNING**

<p>Ask your dealer or qualified personnel to carry out installation work. Do not attempt to install the user interface yourself. Improper installation may result in water leakage, electric shocks or fire.</p>
<p>Consult your local dealer regarding relocation and reinstallation of the user interface. Improper installation work may result in leakage, electric shocks or fire hazards.</p>
<p>Install the user interface in accordance with the instructions in this Installer reference guide. Improper installation may result in water leakage, electric shocks or fire.</p>
<p>Be sure to use only the specified accessories and parts for installation work. Failure to use the specified parts may result in the unit falling down, water leakage, electric shocks or fire.</p>
<p>Install the user interface on a foundation strong enough to withstand the weight of the user interface. Insufficient strength may result in the user interface falling down and causing injury.</p>
<p>Electrical work must be performed in accordance with the relevant local and national regulations and with the instructions in this Installer reference guide. Be sure to use a dedicated power supply circuit only. Insufficient power circuit capacity and improper workmanship may result in electric shocks or fire.</p>
<p>Always perform installation work with the power turned off. Touching electric parts may result in electric shock.</p>
<p>Do not disassemble, reconstruct or repair. This may result in electric shock and/or fire.</p>
<p>Make sure that all wiring is secured, the specified wires are used and that there is no strain on the terminal connections or wires. Improper connections or securing of wires may result in abnormal heat build-up or fire.</p>
<p>The choice of materials and installations must comply with the applicable national and international standards.</p>

Safety Considerations

 **CAUTION**

To avoid leakage and electric shock due to entry of water or insects, fill the wiring through hole with putty.

To avoid electric shocks, do not operate with wet hands.

Do not wash the user interface with water, as this may result in electric shocks or fire.

Install the indoor and outdoor units, power cord and connection wires at least 3.3ft (1m) away from televisions or radios to prevent interference and noise.

(Depending on the incoming signal strength, a distance of 3.3ft (1m) may not be sufficient to eliminate noise.)

Do not install the air conditioner in the following locations:

1. Where there is a high concentration of mineral oil spray or vapor (e.g. a kitchen).
Plastic parts may deteriorate and fall off which could result in water leakage.
2. Where corrosive gas, such as sulphurous acid gas, is produced.
Corroding of copper pipes or soldered parts may result in refrigerant leakage.
3. Near machinery emitting electromagnetic radiation.
Electromagnetic radiation may disturb the operation of the control system and result in malfunctioning of the unit.
4. Where flammable gas may leak, where there is carbon fiber or ignitable dust suspensions in the air or where volatile flammables such as paint thinner or gasoline are handled.
Operating the unit in such conditions may result in fire.
5. High temperature areas or direct flames.
Overheating and/or fire may occur.
6. Moist areas or places which may be exposed to water.
If water enters the user interface, electric shock may be caused and the inner electronics may fail.

When the thermostat function of the user interface is used, select the installation location while considering it should be a place:

- Where the average temperature in the room can be detected.
- Which is not exposed to direct sunlight.
- Which is not near a heat source.
- Which is not affected by the outside air or air draught due to, for example, opening/closing of doors, the air outlet of the indoor unit or the like.
- Which is NOT located outdoors.

Accessories

2. Accessories

Not included but required: BRCW901A*.

Item No.	Length
BRCW901A03	10ft
BRCW901A08	26ft

3. User interface installation procedure

3-1 Determine where to install the user interface.

Make sure to follow "1. Safety Considerations" when determining the location.

3-2 Make a wiring through hole on the wall if the wires are coming out from the rear.

[Unit: inch (mm)]

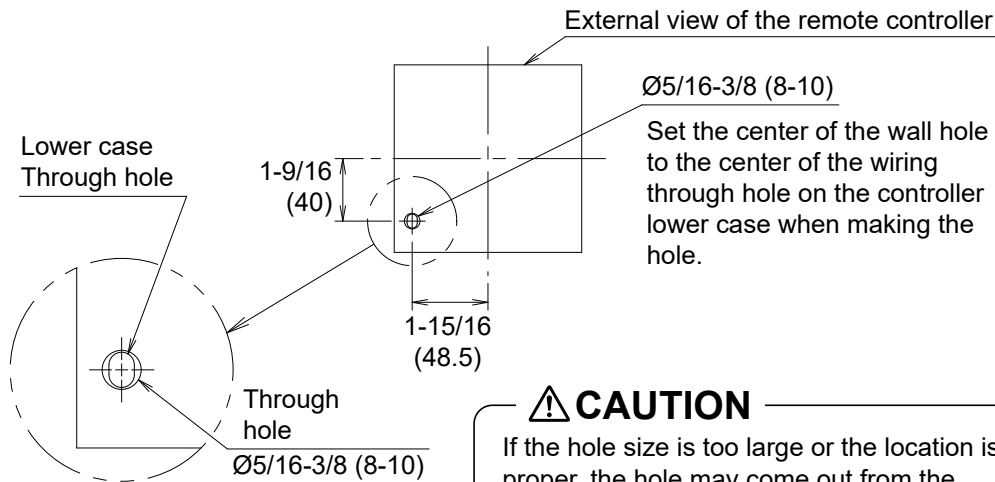

3-3 Remove upper case.

Insert a screwdriver in the recess of lower case to remove the upper case (2 points).

Remote controller printed-circuit board is installed on the upper case. Be careful not to damage the printed-circuit board with the screwdriver.

Be careful not to let dust or moisture touch the printed-circuit board.

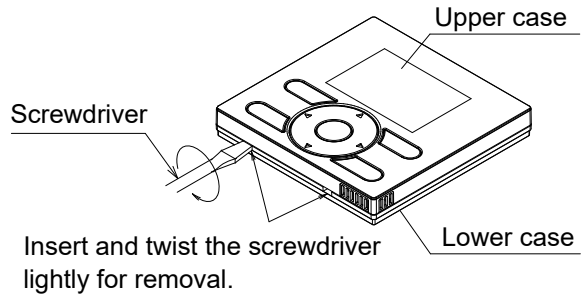

3-4 Determine the direction of the controller wiring outlet (rear outlet, left outlet, top left outlet).

3-4-1 Rear outlet

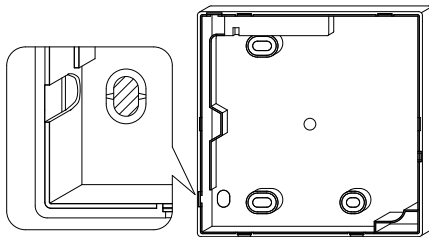

Cut off the resin area (hatched area).

3-4-2 Left outlet

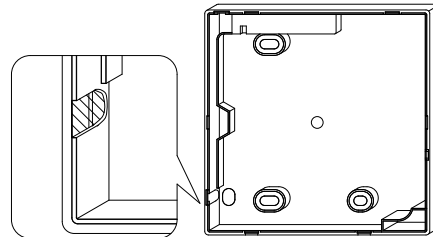

Cut off the thin area (hatched area) with nippers or the like and then remove the burrs with a file or the like.

3-4-3 Top left outlet

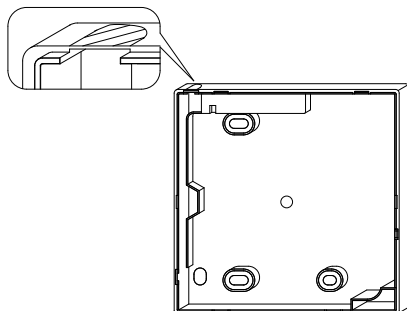

Cut off the thin area (hatched area) with nippers or the like and then remove the burrs with a file or the like.

User interface installation procedure

3-5 Securing the user interface adapter.

Remove the upper case of the user interface adapter and secure the lower case assembly.

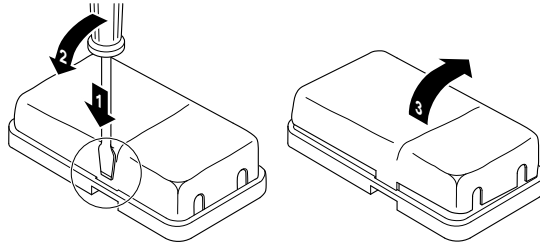

Mounting with supplied wood screws

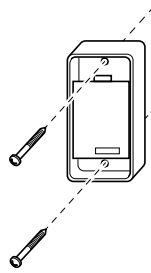

Mounting with supplied double-face adhesive tape

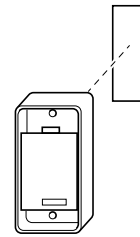

3-6 Conduct wiring.

3-6-1 Connections overview

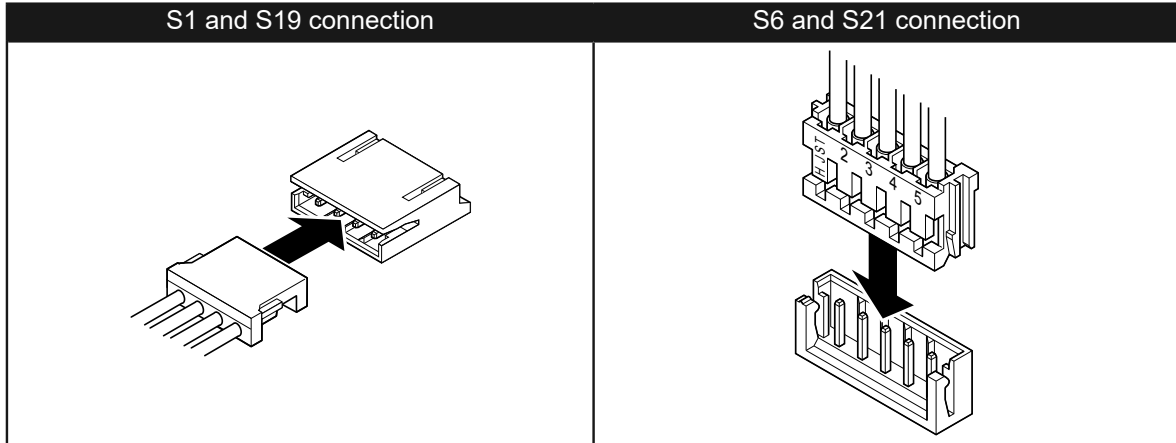

3-6-2 Rear outlet

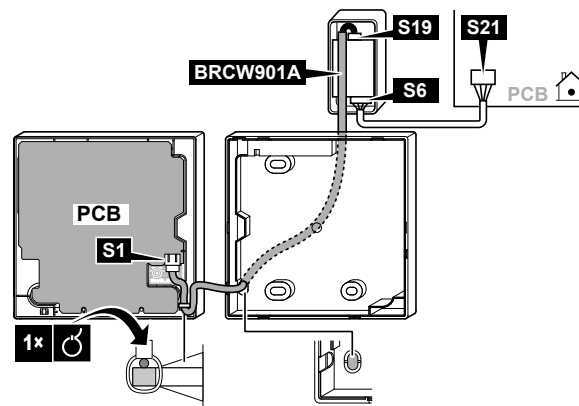

3-6-3 Left outlet

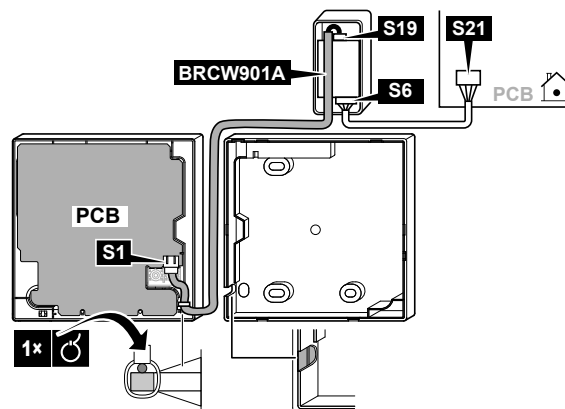

User interface installation procedure

3-6-4 Top left outlet

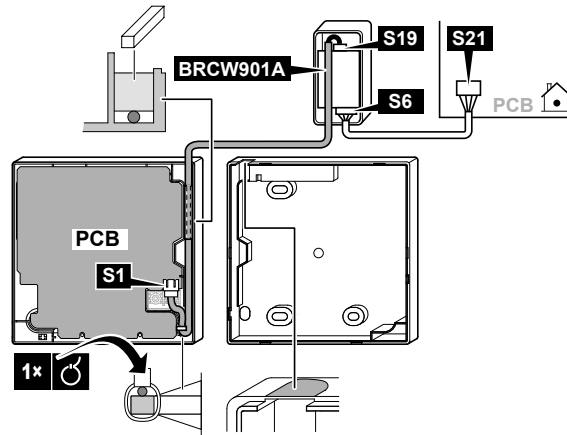

CAUTION

- Do not perform wiring close to a power line in order to avoid electrical noise (external noise).
- Seal the wiring draw-in port securely with putty (field supply) to prevent the entry of insects or the like.

CAUTION

- The adapter does not provide any form of strain release. The installer must provide something to release the strain on the cables near the adapter.

NOTICE

- Ground both ends of the BRCW901A* option cable.

3-7 Fixing procedure of the lower case.

In the case of wiring a user interface through the rear outlet, perform the wiring through the outlet hole in the lower case before it is installed on the wall.

3-7-1 Wall mounting

Secure by using furnished wood screws (2 pcs.).

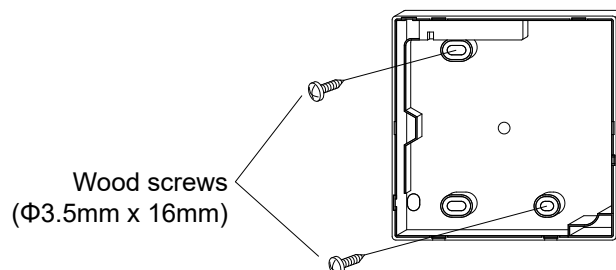

3-7-2 Switchbox mounting

Secure by using furnished small screws (2 pcs).

[Unit: inch (mm)]

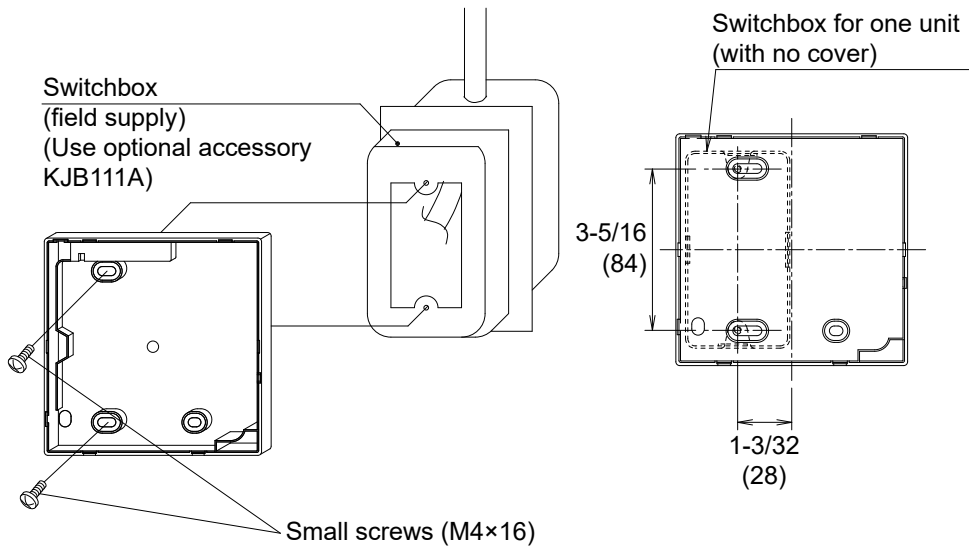
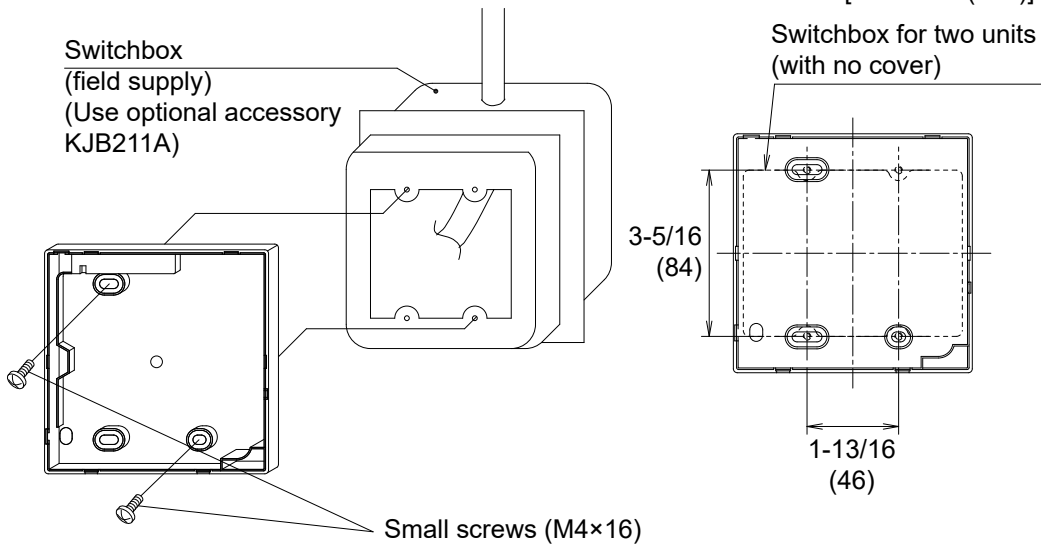

⚠ CAUTION

- Select a flat surface for installation if possible.
- Do not tighten the installation screws too much to avoid deforming the lower case.

User interface installation procedure

3-8 Attach the upper case.

- Align the upper case with the tabs of the lower case (6 points) and insert the upper case.
- Be careful not to pinch the wiring when attaching.
- Peel off the protective seal which is attached to the upper case.

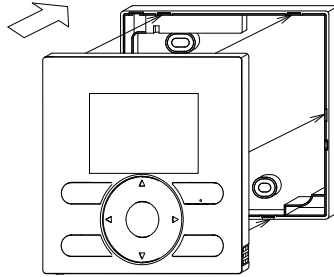

Functions and menu items of the user interface buttons

4. Functions and menu items of the user interface buttons

4-1 Functions and menu items

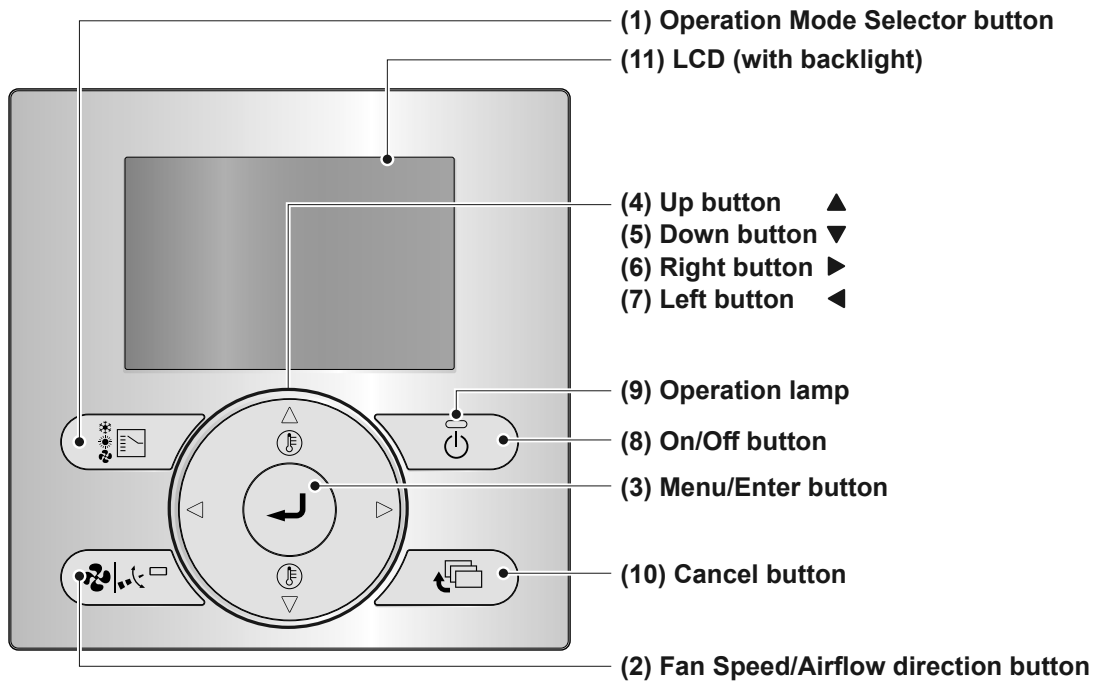

(1) Operation Mode Selector button

- This button is enabled by default. To disable, refer to "13. Prohibit Buttons" on page 27.
- Press this button to select the operation mode of your preference.
- Available modes may vary with the connected model.

(2) Fan Speed/Airflow direction button

- Used to change the fan speed and airflow direction.
- Available fan speeds and airflow directions may vary with the connected model.

(3) Menu/Enter button

- This button is enabled by default. To disable, refer to "4-2 Enable/disable the Menu/Enter and Cancel button" on page 14.
- Used to display the main menu or enter the selected item. (For details on the main menu, see the User reference guide.)

Main menu*

- Airflow Direction
- Energy Saving Options
- Schedule
- Maintenance Information
- Configuration
- Current Settings
- Clock & Calendar
- Language

(4) Up button ▲

- Used to raise the set temperature.
- The next item on the upper side will be highlighted. (Keep pressing the button to cycle through the values or items.)
- Used to change the selected item.

Functions and menu items of the user interface buttons

(5) Down button ▼

- Used to lower the set temperature.
- The next item on the lower side will be highlighted.
(Keep pressing the button to cycle through the values or items.)
- Used to change the selected item.

(6) Right button ►

- Used to highlight the next item on the right-hand side.
- The display contents are changed to the next screen.

(7) Left button ◀

- Used to highlight the next items on the left-hand side.
- The display contents are changed to the previous screen.

(8) On/Off button

- Press to start or stop the air conditioner.

(9) Operation lamp (Green)

- This lamp lights up during operation.
- This lamp will blink if an error or mode conflict occurs.
- This lamp is not lit when the unit operation is OFF.

(10) Cancel button

- Used to return to the previous screen.
- Press and hold this button for 4 seconds or longer to display the Service Settings menu.

(11) LCD (with backlight)

- The backlight will be lit for approximately 30 seconds when one of the buttons is pressed.
- The actions linked to the buttons, except for the On/Off button, are not carried out when the backlight is not lit.

Service Settings menu*



*Available menu items are depending on the connected model.

**Not displayed in case of multi-split setup.

⚠ CAUTION

- To operate the Up/Down/Left/Right button, always press ▲, ▼, ◀, or ▶.

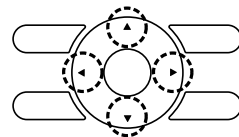

Functions and menu items of the user interface buttons

4-2 Enable/disable the Menu/Enter and Cancel button

To disable the Menu/Enter and Cancel button in the Basic screen, proceed as follow:

1. Keep the ► button pressed.
2. Push the 3 indicated keys simultaneously while keeping the ► button pressed.

To enable the Menu/Enter and Cancel button in the Basic screen, follow the same procedure.

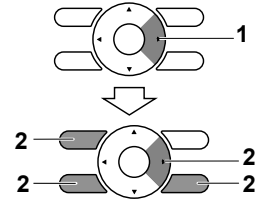

4-3 Description of button operation

<Main Menu>

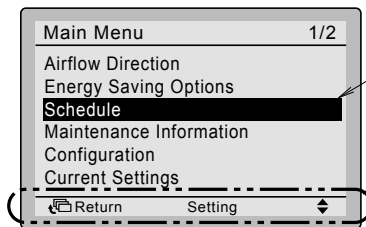

Highlighted display (selected items)

Instructions for manipulating the buttons will appear.

Power-on

5. Power-on

- Check that the indoor/outdoor unit wiring is completed.
- Check that the switchbox cover of the indoor and outdoor units are closed before powering on.

Split air conditioner is connected to a user interface

5-1 Turn on the power.

5-2 "Checking the connection.
Please stand by." is displayed.

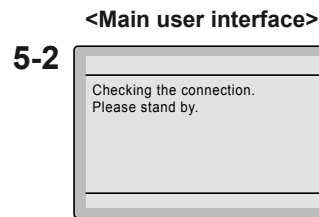

NOTE

When the text on the left is displayed, the backlight does not light up when one of the buttons is pressed.



<Basic screen>

5-3 The Basic screen is displayed.

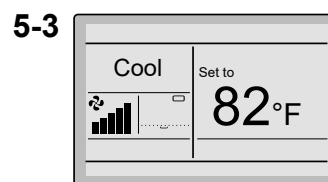

NOTE

- When selecting a different language, refer to "12. Language" on page 26.
- The displayed operation mode on the user interface at first startup depends on the operation mode of the indoor unit.

6. Field settings

6-1 Press and hold the Cancel button for 4 seconds or longer. The Service Settings menu is displayed.

6-1

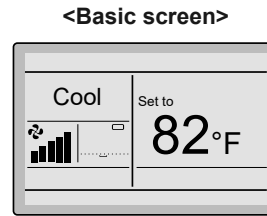

6-2 Select **Field Settings** and press the Menu/Enter button.

6-2

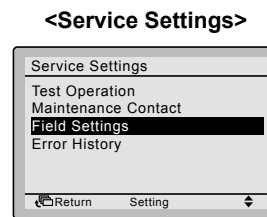

6-3 Highlight the "Mode No.", and select the desired "Mode No." by using the ▲▼ (Up/Down) buttons. For the most commonly used field settings, refer to page 17.

6-3

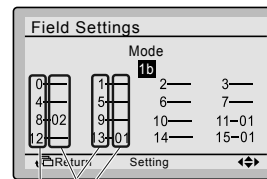

SECOND CODE NO.
FIRST CODE (SW) NO.

- The current settings are displayed.
- CODE NO. " -- " means that there is no function available.

6-4 Highlight the SECOND CODE of the FIRST CODE NO. to be changed and select the desired SECOND CODE NO. by using the ▲▼ (Up/Down) buttons. Multiple identical mode number settings are available.

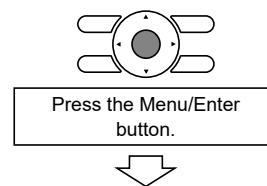

6-5 Press the Menu/Enter button. The confirmation screen is displayed.

6-5

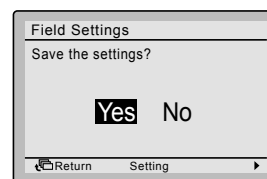

6-6 Select **Yes** and press the Menu/Enter button. The settings are saved and the Field settings screen returns.

6-6



Field settings

- 6-7** After all changes are completed, press the Cancel button twice.
- 6-8** The backlight goes out and "Checking the connection. Please stand by" is displayed during initialization. After the initialization, the Basic screen returns.

Mode No.	First Code No.	Description of the setting	Second code No.			
			01	02	03	04
1b	8	Daylight Saving Time	Disable	Enable*	—	—
	11	(Private use)	NA*	NA	—	—
	13	Basic screen display	Icon+Text*	Icon	—	—
	15	(Private use)	NA*	NA	—	—
1c	0	(Private use)	NA	NA*	—	—
	2	(Private use)	NA	NA*	—	—
	4	(Private use)	NA	NA*	—	—
	5	(Private use)	NA*	—	—	—
	6	(Private use)	NA*	—	—	—
	14	(Private use)	NA*	NA	—	—
1e	1	(Private use)	NA	NA*	—	—
	2	Setback function	Do not use	Heat only	Cool only	Cool and Heat*
	5	(Private use)	NA	NA*	—	—
	6	(Private use)	NA	NA*	—	—
	8	(Private use)	NA*	—	—	—
	9	(Private use)	NA	NA*	—	—
	a	(Private use)	NA*	—	—	—

* Factory default setting

Test operation method (pair split only)

7. Test operation method (pair split only)

* In case of multi-split models, see the manual attached to the outdoor unit.

NOTE

- In case of multi-split setup, test operation cannot be used.

Also see the installation manuals attached to the indoor unit and the outdoor unit.

- Check that the wiring of the indoor unit and the outdoor unit is completed.
- Check that the switchbox cover of the indoor unit and the outdoor unit is closed.
- Perform the test operation according to the following procedure.

NOTE

- The backlight will be lit for approximately 30 seconds when pressing one of the operation buttons.
- Operate the buttons only when the backlight is lit. However, the On/Off button can be operated when the backlight is not lit.

7-1 Make sure the electric work is properly completed and proper voltage is available before turn on the power.

CAUTION

Make sure that the outer panel and piping cover are closed before operation (danger of electric shock).

7-2 Confirm that both the liquid and gas stop valves are opened.

7-3 Set the operation mode to cooling by using the Operation Mode Selector button.

7-3
7-4

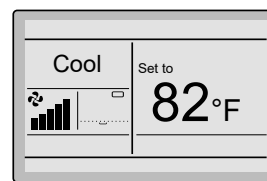

Press and hold the Cancel button for 4 seconds or longer while the backlight is lit.

7-4 Press and hold the Cancel button for 4 seconds or longer. The Service Settings menu is displayed.

<Service Settings>

Test operation method (pair split only)

7-5 Select **Test Operation** and press the Menu/Enter button. The Basic screen returns and "Test operation" is displayed.



Press the Menu/Enter button.

7-6 Press the On/Off button within about 10 seconds. Test operation starts. Check the operation condition for 3 minutes.

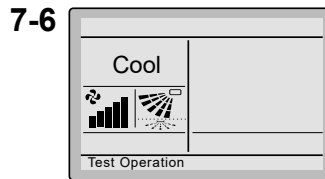

Press the On/Off button (within 10 seconds).

NOTE

Test operation can also be started by first performing 7-6, followed by 7-5.

7-7 Press the Menu/Enter button in the Basic screen. The Main menu is displayed.

<Main menu>

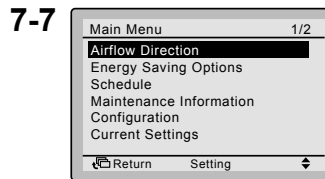

Press the Menu/Enter button.

7-8 Select **Airflow Direction** and press the Menu/Enter button.

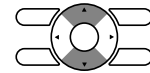
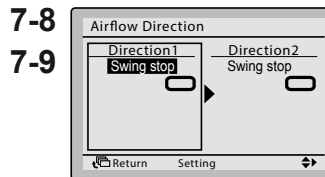

Change the airflow direction using the ▲▼ (Up/Down) buttons.

7-9 Press the ▲▼ buttons to select the desired airflow direction and press the Menu/Enter button. The Basic screen returns.



Press the Menu/Enter button.

7-10 Press and hold the Cancel button for 4 seconds or longer in the Basic screen. The Service Settings menu is displayed.

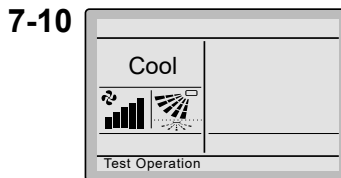

Press and hold the Cancel button for 4 seconds or longer while the backlight is lit.

<Service Settings menu>

Test operation method (pair split only)

7-11 Select **Test Operation** in the Service Settings menu and press the Menu/Enter button. The Basic screen returns and normal operation is possible.

7-11

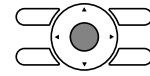
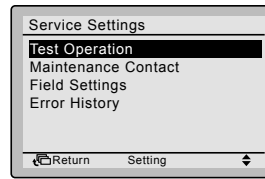

Press the Menu/Enter button.

<Basic screen>

7-12 Check the functions according to the User reference guide.

7-13 When the decoration panel is not installed, turn off the power after test operation finishes.

NOTE

Test operation will automatically finish after 30 minutes.

CAUTION

- If the interior work is not completed when the test operation is finished, explain to the customer that he should not operate the unit until the interior work is completed in order to protect the indoor unit.
- (If the indoor unit is operated, the indoor unit may be contaminated with the materials which arise from paints or adhesives during the interior work and water splash or water leak may occur.)

CAUTION

- If it is not possible to operate the unit due to any malfunction, refer to **Malfunction diagnosis method**.
- When the test operation finishes, check that the error code history is not displayed in the Maintenance Information screen according to the following procedure.

7-14 Press the Menu/Enter button in the Basic screen. The Main menu is displayed.

7-14

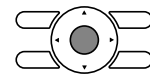
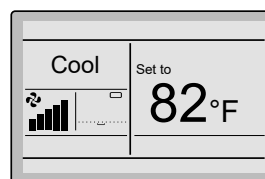

Press the Menu/Enter button.

<Main menu>

7-15 Select **Maintenance Information** and press the Menu/Enter button.

7-15

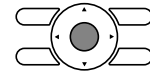
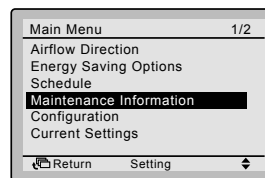

Press the Menu/Enter button.

Test operation method (pair split only)

7-16 The Maintenance Information screen is displayed. Check that the last error code is not displayed in the screen.

7-17 If the last error code is displayed, conduct the malfunction diagnosis referring to "Error code list" in the installation manual of the indoor unit. After the malfunction diagnosis finishes, press and hold the On/Off button for 4 seconds or longer in the "Maintenance Information" screen to erase the error code history.

7-16
7-17

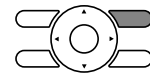
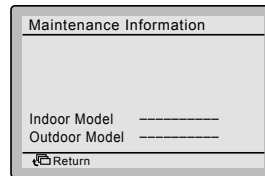

Press and hold the On/Off button for 4 seconds or longer.

NOTE

If no error code is displayed when this procedure is followed, the system has completed the test operation normally.

Malfunction diagnosis method

- When the user interface displays any item in the following table, inspect the details in the table.
- If an error occurs, "Error: Push Menu button" or "⚠" is displayed. Conduct the malfunction analysis referring to "Error code list" in the installation manual of the indoor unit. To see the RC Error History screen, refer to "8. Checking procedure of Error History".

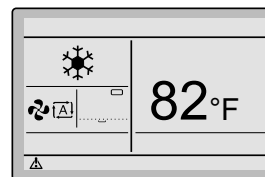
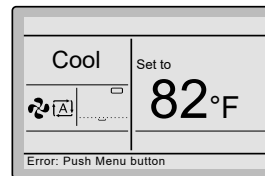

User interface display	Description
No display	<ul style="list-style-type: none"> • Power outage, power voltage failure or open-phase • Wrong wiring (between indoor and outdoor units) • Indoor PCB assembly failure • User interface wiring disconnection • User interface failure • Blown fuse (outdoor unit)
Display "Checking the connection Please stand by" is shown.*	<ul style="list-style-type: none"> • Indoor PCB assembly failure • Wrong wiring (between indoor and outdoor units)

* Though "Checking the connection Please stand by" is displayed for up to 180 seconds after powering on, this does not mean there is a failure. (Determine after 180 seconds if error code "U5" is displayed.)

Checking procedure of Error History

8. Checking procedure of Error History

8-1 Press and hold the Cancel button for 4 seconds or longer in the Basic screen. The Service Settings menu is displayed.

8-1 **<Basic screen>**

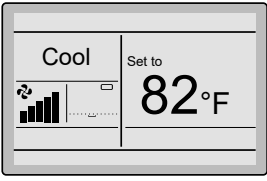
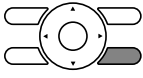
Press and hold the Cancel button for 4 seconds or longer while the backlight is lit.

8-2 Select **Error History** and press the Menu/Enter button. The Error History menu is displayed.

8-2 **<Service Settings>**

Press the Menu/Enter button.

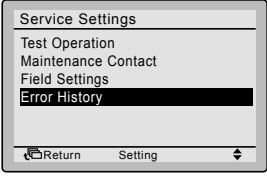
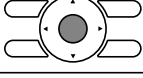
8-3 Select **RC Error History** and press the Menu/Enter button. The error codes can be confirmed in the RC Error History screen.

8-3 **Error History**

Press the Menu/Enter button.

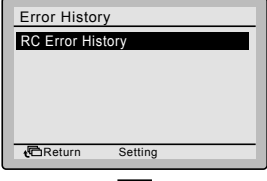
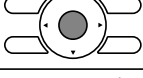
8-4 In the RC Error History screen the last 10 items are displayed in order.

8-4 **RC Error History 1/3**

Error	Date	Time
01	-/-/--:--	--:--
02	-/-/--:--	--:--
03	-/-/--:--	--:--
04	-/-/--:--	--:--

8-5 Press the Cancel button in the RC Error History screen 3 times. The Basic screen returns.

Latest record

Registration method of the Maintenance Contact information

9. Registration method of the Maintenance Contact information

- Registration of the service contact information.

9-1 Press and hold the Cancel button for 4 seconds or longer in the Basic screen. The Service Settings menu is displayed.

<Basic screen>

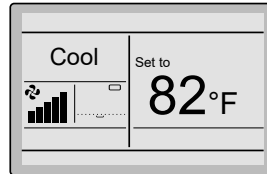

Press and hold the Cancel button for 4 seconds or longer while backlight is lit.

9-2 Select **Maintenance Contact** and press the Menu/Enter button. The "Maintenance Contact" screen is displayed.

<Service Settings>

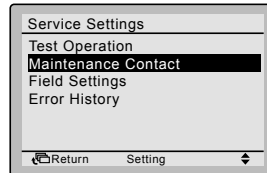

Press the Menu/Enter button.

9-3 Select **Maintenance Contact** and press the Menu/Enter button.

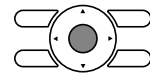
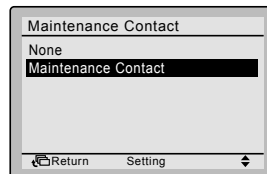

Press the Menu/Enter button.

9-4 Enter the telephone number by using the ▲▼ (Up/Down) buttons. Enter from the left to the right and blank digits should be left as " - ".

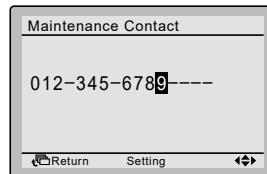

Press the Menu/Enter button.

9-5 Press the Menu/Enter button. The setting confirmation screen is displayed.

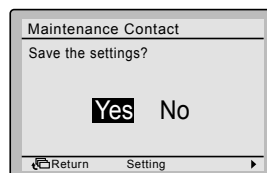

Press the Menu/Enter button.

9-6 Select **Yes** and press the Menu/Enter button. The settings are entered and the Service Settings menu returns.

<Service Settings>

9-7 Press the Cancel button once. The Basic screen returns.

10. Confirmation of registered details

10-1 Press the Menu/Enter button in the Basic screen. The Main menu is displayed.

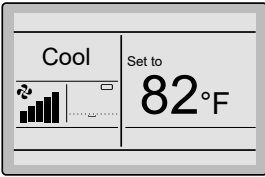
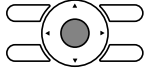

10-1 **<Basic screen>**

Press the Menu/Enter button.

10-2 Select **Maintenance Information** and press the Menu/Enter button. The "Maintenance Information" screen is displayed.

10-2 **<Main menu>**

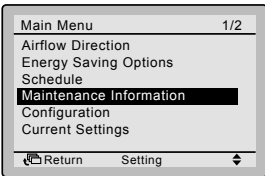
Press the Menu/Enter button.

10-3 Confirm that the contact information is entered correctly.

10-3 **Maintenance Information**

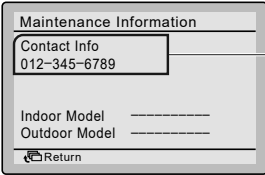

The registered details are displayed.

10-4 Press the Cancel button twice. The Basic screen returns.

Clock & Calendar

11. Clock & Calendar

11-1 Press the Menu/Enter button in the Basic screen. The Main menu is displayed.

<Basic screen>

11-1

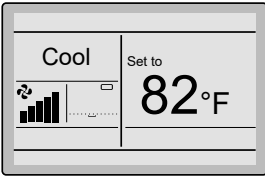



Press the Menu/Enter button.

↓

11-2 Select **Clock & Calendar** and press the Menu/Enter button. The "Clock & Calendar" menu is displayed.

<Main menu>

11-2

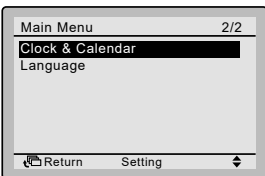





Press the Menu/Enter button.

↓

11-3 Select **Date & Time** and press the Menu/Enter button. The "Date & Time" screen is displayed.

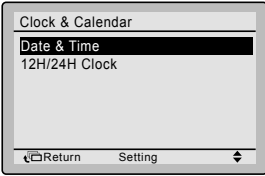
11-3







Press the Menu/Enter button.

↓

11-4 Select the "Year", "Month", "Day" and time by using the ◀▶ (Left/Right) buttons and change the value by using the ▲▼ (Up/Down) buttons. When the buttons are pressed and held, the values change continuously.

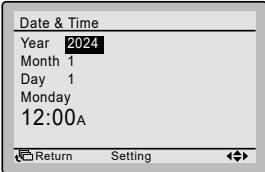
11-4
11-5





Press the Menu/Enter button.

11-5 Press the Menu/Enter button. The confirmation screen is displayed.

NOTE

The day of the week is set automatically.

11-6 Select **Yes** and press the Menu/Enter button. The settings are confirmed and the Basic screen returns.

11-6

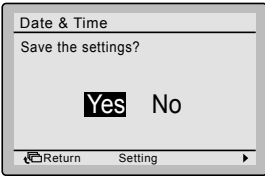



Press the Menu/Enter button.

<Basic screen>

NOTE

If a power outage lasts longer than 48 hours, the time is reset and needs to be set again.

12. Language

12-1 Press the Menu/Enter button in the Basic screen. The Main menu is displayed.

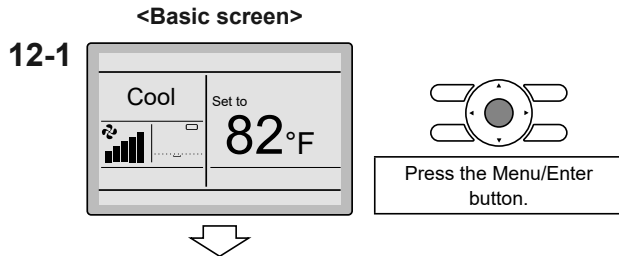

12-2 Select **Language** and press the Menu/Enter button. The "Language" screen is displayed.

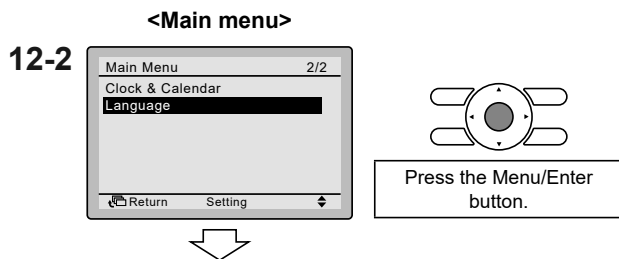

12-3 Press the ▲▼ (Up/Down) buttons to select the preferred language (English, French or Spanish) and press the Menu/Enter button. The settings are confirmed and the Basic screen returns.

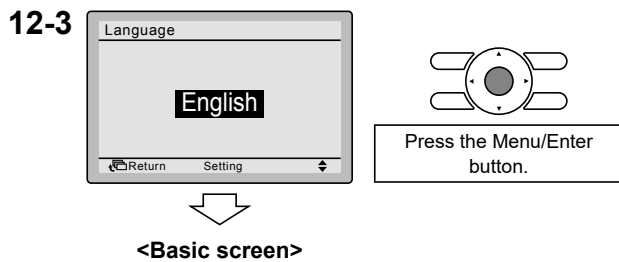

Prohibit Buttons

13. Prohibit Buttons

- Restriction of the number of operable buttons.

13-1 Press the Menu/Enter button in the Basic screen. The Main menu is displayed.

13-1 **<Basic screen>**

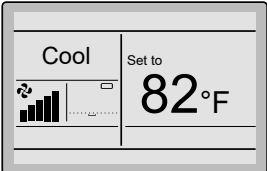

Press the Menu/Enter button.

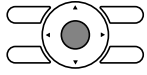

13-2 **Lock Function** can be made visible by pressing the Menu/Enter button for 4 seconds.

13-2 **<Main menu>**

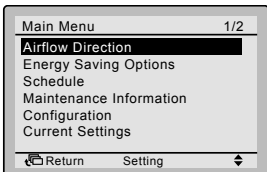

Press the Menu/Enter button for 4 seconds.

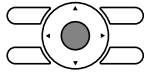

13-3 Select **Lock Function** and press the Menu/Enter button. The "Lock Function" menu is displayed.

13-3

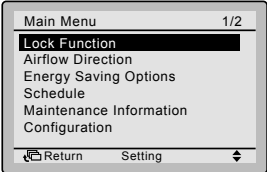

Press the Menu/Enter button.

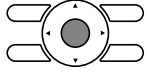

13-4 Select **Prohibit Buttons** and press the Menu/Enter button. The "Prohibit Buttons" screen is displayed.

13-4

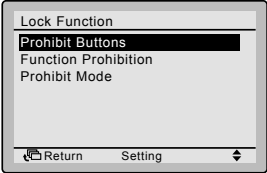

Press the Menu/Enter button.

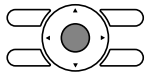

13-5 Select "Up/Down/L/R", "On/Off", "Mode" or "Fan Speed" by using the ◀▶ (Left/Right) buttons and "Lock/Unlock" by using the ▲▼ (Up/Down) buttons.

13-5 **13-6**

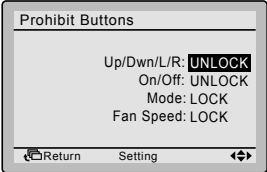

Press the Menu/Enter button.

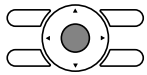

13-6 Press the Menu/Enter button. The confirmation screen is displayed.

13-7 Select **Yes** and press the Menu/Enter button. The settings are entered and the Basic screen returns.

13-7

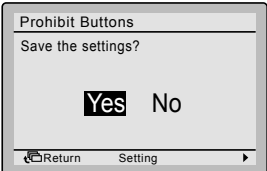

Press the Menu/Enter button.

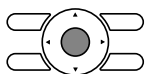

<Basic screen>

14. Function Prohibition

- Restriction of the number of operable functions.

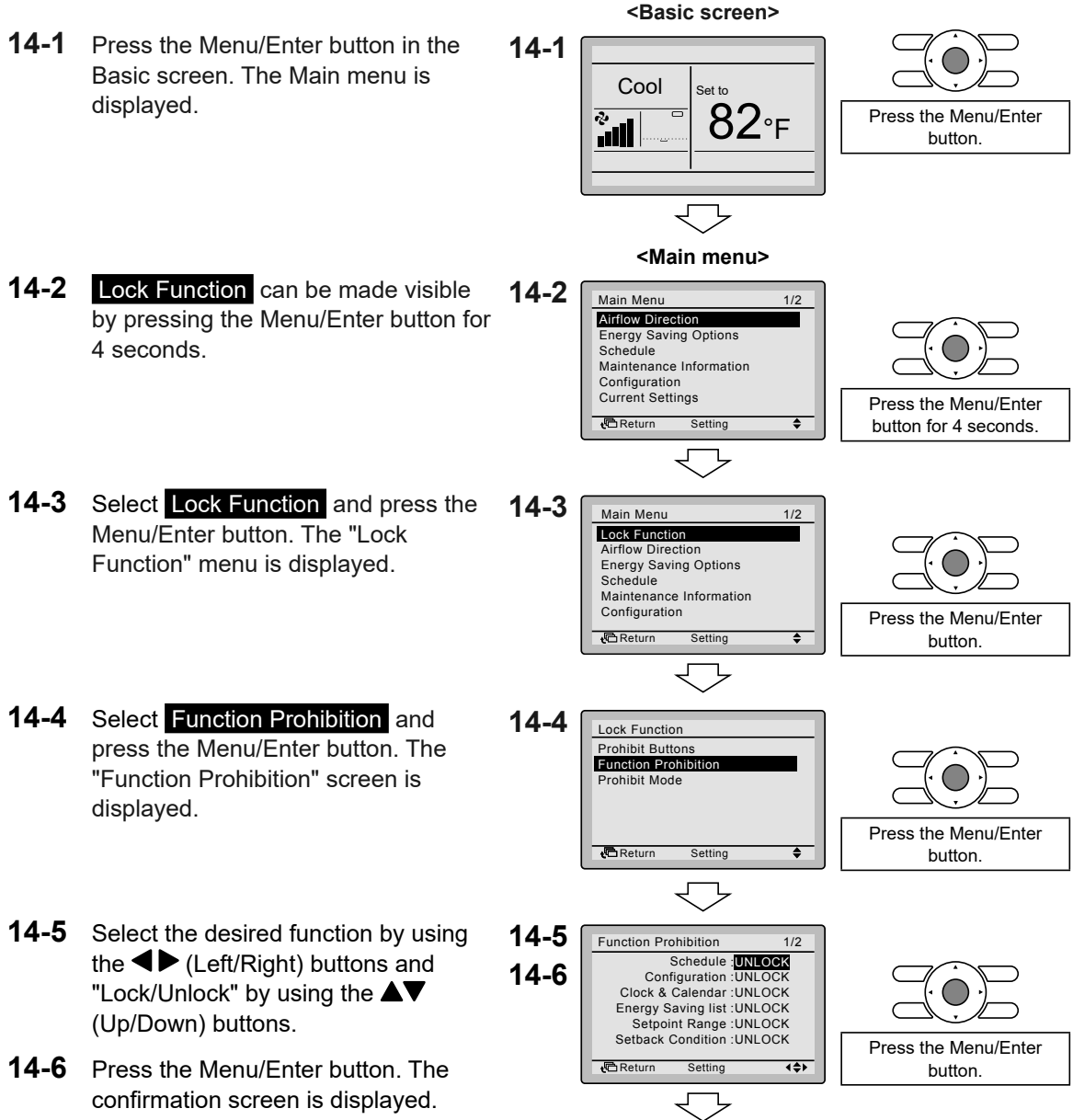

Prohibit Mode

14-7 Select **Yes** and press the Menu/Enter button. The settings are entered and the Basic screen returns.

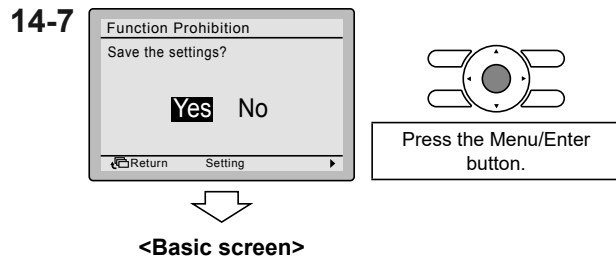

NOTE

- When a function is prohibited, the icon will be displayed next to the function.

15. Prohibit Mode

- Restriction of the number of operable modes.

15-1 Press the Menu/Enter button in the Basic screen. The Main menu is displayed.

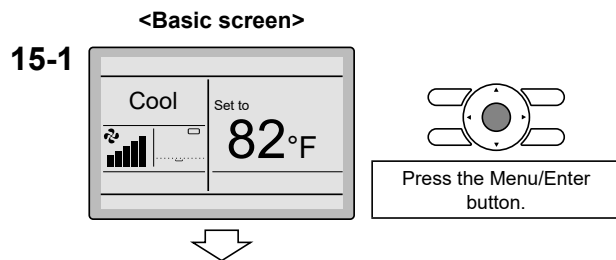

15-2 **Lock Function** can be made visible by pressing the Menu/Enter button for 4 seconds.

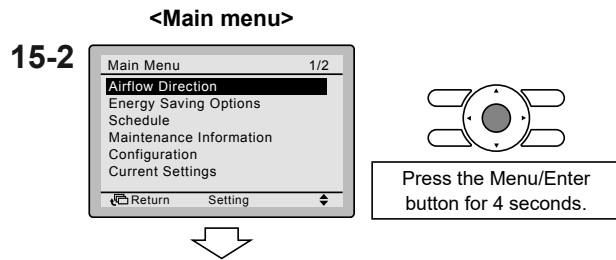

15-3 Select **Lock Function** and press the Menu/Enter button. The "Lock Function" menu is displayed.

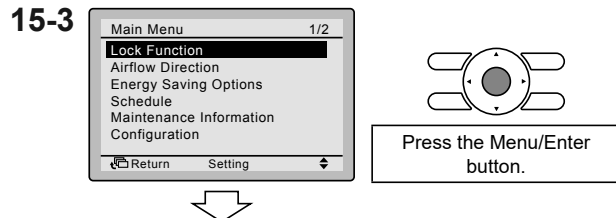

Prohibit Mode

15-4 Select **Prohibit Mode** and press the Menu/Enter button. The "Prohibit Mode" screen is displayed.

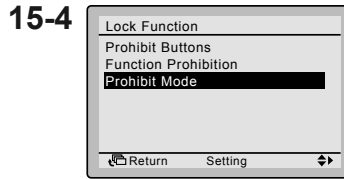

Press the Menu/Enter button.

15-5 Select "Fan", "Cool", "Heat", "Auto" or "Dry" using the ◀▶ (Left/Right) buttons and "Enable/Disable" the selected mode by using the ▲▼ (Up/ Down) buttons.

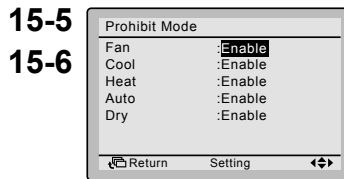

Press the Menu/Enter button.

15-6 Press the Menu/Enter button. The confirmation screen is displayed.

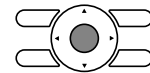
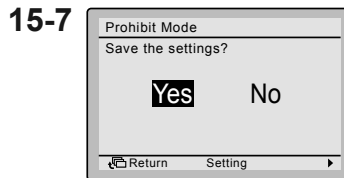

Press the Menu/Enter button.

15-7 Select **Yes** and press the Menu/Enter button. The settings are confirmed and the Basic screen returns.

<Basic screen>

NOTE

- When the currently active mode is locked, this mode will still be active upon returning to the Basic screen. Only when the mode is changed, the disabled mode will not be available anymore. When all modes are locked, it is not possible to change to another mode other than the currently active mode.

13.3 <BRC073A6> Wired Remote Controller (Operation)



Safety Considerations

The original instructions are written in English. All other languages are translations of the original instructions.





This appliance is not intended to be used by persons, including children, with reduced physical, sensory or mental capabilities or lack of experience and knowledge, unless they are supervised or have been given instructions on how to use the appliance by a person responsible for their safety. Children should be supervised to ensure that they do not play with the appliance.

Please read these Safety Considerations carefully before installing the remote controller.





- This manual classifies the precautions into WARNING and CAUTION. They both contain important information regarding safety. Be sure to follow all the precautions below.

 WARNING	Failure to follow these instructions properly may result in personal injury or loss of life.
 CAUTION	Failure to observe these instructions properly may result in property damage or personal injury, which may be serious depending on the circumstances.







- The following pictograms are used in this manual.

	Never do.		Always follow the instructions given.
	Be sure to ground the unit.		Absolutely keep wet hands away.
	Absolutely keep water and moisture away.		







■ About Remote Controller

 WARNING	
	<ul style="list-style-type: none"> • Do not install the remote controller by yourself. Improper installation may result in electric shocks or fire. Consult your Daikin dealer.
	<ul style="list-style-type: none"> • Do not modify or repair the remote controller. This may result in electric shocks or fire. Consult your Daikin dealer.
	<ul style="list-style-type: none"> • Do not relocate or reinstall the remote controller by yourself. Improper installation may result in electric shocks or fire. Consult your Daikin dealer.
	<ul style="list-style-type: none"> • Do not use flammable materials (e.g., hair spray or insecticide) near the product. Do not clean the product with organic solvents such as paint thinner. The use of organic solvents may cause crack damage to the product, electric shocks or fire.











Items to be Strictly Observed

 CAUTION	
	<ul style="list-style-type: none"> • Do not play with the unit or its remote controller. Accidental operation by a child may result in impairment of bodily functions and harm health.
	<ul style="list-style-type: none"> • Never disassemble the remote controller. Touching the interior parts may result in electric shocks or fire. Consult your Daikin dealer or authorized contractor for internal inspections and adjustments.
	<ul style="list-style-type: none"> • To avoid electric shocks, do not operate with wet hands.
	<ul style="list-style-type: none"> • Do not wash the remote controller. Doing so may cause electric leakage and result in electric shocks or fire.
	<ul style="list-style-type: none"> • Do not leave the remote controller wherever there is a risk of wetting. If water gets into the remote controller there is a risk of electrical leakage and damage to electronic components.















■ Indoor Unit and Outdoor Unit

 WARNING	
	<ul style="list-style-type: none"> • Be aware that prolonged, direct exposure to cool or warm air from the air conditioner or to air that is too cold or too warm can be harmful to your physical condition and health.
	<ul style="list-style-type: none"> • Do not place objects, including rods, your fingers, etc. in the air inlet or outlet. Injury may result due to contact with the air conditioner's high-speed fan blades.
	<ul style="list-style-type: none"> • Contact professional personnel about attachment of accessories and be sure to use only accessories specified by the manufacturer. If a defect results from your own workmanship, it may result in water leaks, electric shock or fire.
	<ul style="list-style-type: none"> • Do not use the product in atmospheres contaminated with oil vapor, such as cooking oil or machine oil vapor. Oil vapor may cause crack damage, electric shocks or fire.
	<ul style="list-style-type: none"> • Do not use the product in places with excessive oily smoke, such as cooking rooms or in places with flammable gas, corrosive gas or metal dust. Using the product in such places may cause fire or product failures.











Items to be Strictly Observed

 WARNING	
	<ul style="list-style-type: none"> • Beware of fire in case of refrigerant leakage. If the air conditioner is not operating correctly, i.e. not generating cool or warm air, refrigerant leakage could be the cause. Consult your dealer for assistance. The refrigerant within the air conditioner is safe and normally does not leak. However, in the event of a leakage, contact with a naked burner, heater or cooker may result in generation of noxious gas. Do not longer use the air conditioner until a qualified service person confirms that the leakage has been repaired.
	<ul style="list-style-type: none"> • In the case of using a load breaker provided with a fuse, make sure that the capacity of the fuse is correct. Use of an ordinary conductive wire may cause malfunctions or fire.
	<ul style="list-style-type: none"> • Do not use the power supply breaker to start or stop the air conditioner. Otherwise, fire or water leakage may result. Furthermore, the fan will rotate abruptly if power failure compensation is enabled, which may result in injury.
	<ul style="list-style-type: none"> • Be sure to ground the unit. Do not ground the unit to a utility pipe, lightning conductor or telephone ground lead. Imperfect grounding may result in electric shocks or fire. A high surge current from lightning or other sources may cause damage to the air conditioner.
	<ul style="list-style-type: none"> • When the air conditioner is malfunctioning (giving off a burning odor, etc). turn off the power and contact your local dealer. Continued operation under such circumstances may result in a failure, electric shocks or fire hazards.
	<ul style="list-style-type: none"> • Consult your local dealer regarding what to do in case of refrigerant leakage. When the air conditioner is to be installed in a small room, it is necessary to take proper measures so that the amount of any leaked refrigerant does not exceed the concentration limit in the event of a leakage. Otherwise, this may lead to an accident due to oxygen depletion.
	<ul style="list-style-type: none"> • Be sure to install a ground leakage breaker. Failure to install a ground leakage breaker may result in electric shocks or fire.
	<ul style="list-style-type: none"> • Consult the dealer if the air conditioner submerges owing to a natural disaster such as a flood or typhoon. Do not operate the air conditioner in that case or otherwise a malfunction, electric shock or fire may result.
	<ul style="list-style-type: none"> • Be sure to use a dedicated power supply for the air conditioner. The use of any other power supply may cause heat generation, fire or product failures.

Items to be Strictly Observed

 CAUTION	
	<ul style="list-style-type: none"> • After prolonged use, check the unit stand and its mounts for damage. If left in a damaged condition, the unit may fall and cause injury.
	<ul style="list-style-type: none"> • Do not allow a child to mount on the outdoor unit or avoid placing any object on it. Falling or tumbling may result in injury.
	<ul style="list-style-type: none"> • Do not block air inlets nor outlets. Impaired airflow may result in insufficient performance or trouble.
	<ul style="list-style-type: none"> • To avoid injury, do not touch the air inlet or aluminium fins of the unit.
	<ul style="list-style-type: none"> • Do not remove the outdoor unit's fan guard. The guard protects against the unit's high speed fan, which may cause injury.
	<ul style="list-style-type: none"> • Do not place objects that are susceptible to moisture directly beneath the indoor or outdoor units. Under certain conditions, condensation on the main unit or refrigerant pipes, air filter dirt or drain blockage may cause dripping, resulting in fouling or failure of the object concerned.
	<ul style="list-style-type: none"> • Do not place water containers (flower vases, etc). on the unit, as this may result in electric shocks or fire.
	<ul style="list-style-type: none"> • Do not use the air conditioner for purposes other than those for which it is intended. Do not use the air conditioner for cooling precision instruments, food, plants, animals or works of art as this may adversely affect the performance, quality and/or longevity of the object concerned.
	<ul style="list-style-type: none"> • Do not place appliances that produce naked flames in places exposed to the airflow from the unit as this may impair combustion of the burner.
	<ul style="list-style-type: none"> • Do not place heaters directly below the unit as resulting heat can cause deformation.
	<ul style="list-style-type: none"> • Be sure that children, plants or animals are not exposed directly to airflow from the unit as adverse effects may ensue.
	<ul style="list-style-type: none"> • Do not put flammable containers, such as spray cans, within 1 m from the blow-off mouth. The containers may explode because the warm air output of the indoor or outdoor unit will affect them.
	<ul style="list-style-type: none"> • Do not install the air conditioner at any place where there is a danger of flammable gas leakage. In the event of a gas leakage, build-up of gas near the air conditioner may result in fire hazards.

Items to be Strictly Observed

 CAUTION	
	<ul style="list-style-type: none"> • Do not sit or stand on any unstable base at the time of operating or maintaining the air conditioner. The base may topple down and injury may occur.
	<ul style="list-style-type: none"> • Do not touch the motor when replacing the filter. The motor can be very hot which may result in burns.
	<ul style="list-style-type: none"> • Do not wash the air conditioner with water as this may result in electric shocks or fire.
	<ul style="list-style-type: none"> • Perform ventilation from time to time. Be careful when using the air conditioner with other heating equipment. Insufficient ventilation may result in oxygen deficiency.
	<ul style="list-style-type: none"> • Always stop the operation of the air conditioner and turn OFF the power supply breaker when cleaning. Failure to do so may result in an electric shock or injury.
	<ul style="list-style-type: none"> • Do not wash the interior of the indoor and outdoor units by yourself. Always consult your Daikin dealer. The use of an incorrect washing method or incorrect detergent may damage the resin parts of the indoor unit or cause water leakage. Moreover, malfunctions, smoke generation or ignition may result if the electric parts or the motor in the indoor unit come in contact with a detergent or water.
	<ul style="list-style-type: none"> • Do not place objects in direct proximity of the outdoor unit and do not let leaves and other debris accumulate around the unit. Leaves are a hotbed for small animals which can enter the unit. Once in the unit, such animals can cause malfunctions, smoke or fire when making contact with electrical parts.
	<ul style="list-style-type: none"> • Fix the units securely. If the units are not mounted securely, the units may fall or topple and result in personal injury.
	<ul style="list-style-type: none"> • Arrange the drain to ensure complete drainage. If proper drainage from the outdoor drain pipe does not occur during air conditioner operation, there could be a blockage due to dirt and debris build-up in the pipe. This may result in water leakage from the indoor unit. Under these circumstances, stop the air conditioner operation and consult your dealer for assistance.

Names and Functions

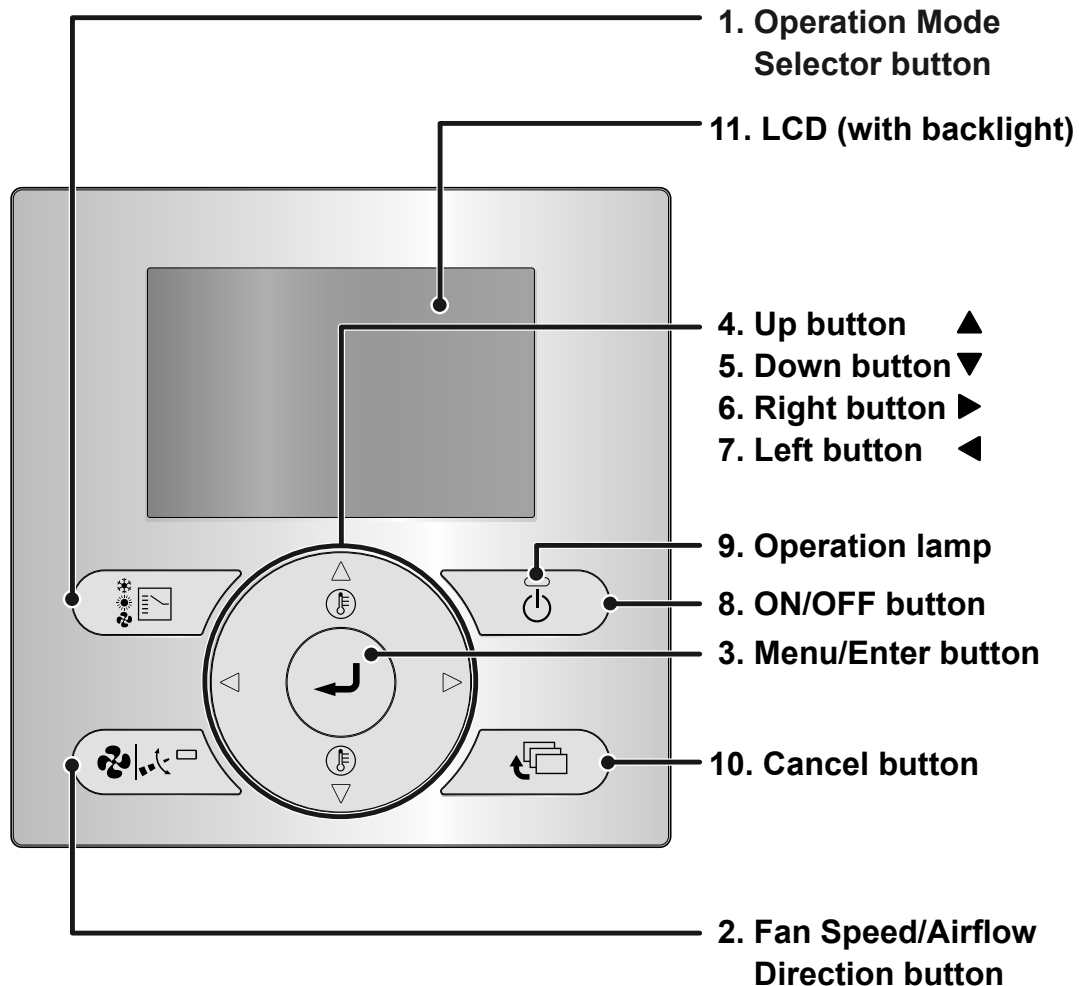

Functions other than the basic operation items (i.e., ON/OFF, operation mode selection, fan speed, up/down direction, and temperature setting) are set from the menu screen.

NOTE

- Do not install the remote controller in places exposed to direct sunlight. Otherwise, the LCD may become discolored and nothing may be displayed.
- Do not pull or twist the remote controller cord. Otherwise, the remote controller may malfunction.
- Do not press the buttons on the remote controller with objects with sharp ends. Otherwise, the remote controller may be damaged or malfunction.

1. Operation Mode Selector button

- Press this button to select the operation mode of your preference. (See "Cool/Heat/Fan/Dry/Auto Operation" on page 12)
- Available modes may vary with the connected model.

2. Fan Speed/Airflow Direction button

- Used to change the fan speed and airflow direction. (See "Cool/Heat/Fan/Dry/Auto Operation" on page 12)
- Available fan speeds and airflow directions may vary with the connected model.

3. Menu/Enter button

- This button is enabled by default. To disable, refer to "Enable/disable the Menu/Enter and Cancel button" on page 11.
- Used to display the Main Menu or enter the selected item (See "Main Menu Items Overview" on page 19).

4. Up button ▲

- Used to raise the set temperature.
- The next item on the upper side will be highlighted.
(Keep pressing the button to cycle through the values or items).
- Used to change the selected item.

5. Down button ▼

- Used to lower the set temperature.
- The next item on the lower side will be highlighted.
(Keep pressing the button to cycle through the values or items).
- Used to change the selected item.

6. Right button ►

- Used to highlight the next items on the right-hand side.
- The display contents are changed to the next screen.

7. Left button ◀

- Used to highlight the next items on the left-hand side.
- The display contents are changed to the previous screen.

8. ON/OFF button

- Press to start or stop the air conditioner.

9. Operation lamp (Green)

- This lamp lights up during operation.
- This lamp is not lit when the unit operation is OFF.
- This lamp blinks if an error or mode conflict occurs.

10. Cancel button

- This button is enabled by default. To disable, refer to "Enable/disable the Menu/Enter and Cancel button" on page 11.
- Used to return to the previous screen.

11. LCD (with backlight)

- The backlight will be lit for approximately 30 seconds when one of the buttons is pressed.
- The actions linked to the buttons, except for the ON/OFF button, are not carried out when the backlight is not lit.

Names and Functions

Liquid Crystal Display

- There are four display methods for the liquid crystal display (LCD) available. The Standard display, which is used by default, and the Detailed display. There is also the possibility to use only Icon or Icon and Text mode (see the Installation manual).
- To change the active display method, select the desired display method in the Display Method screen (See "Display" on page 34).
- The displayed contents on the screen may vary with the operation mode of the connected models. (E.g.: The following display will appear when the air conditioner is in heating operation).

Standard display

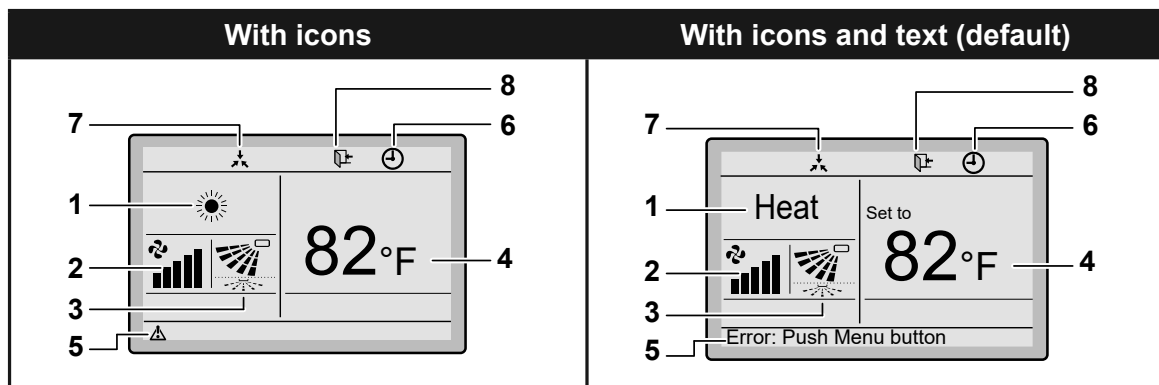





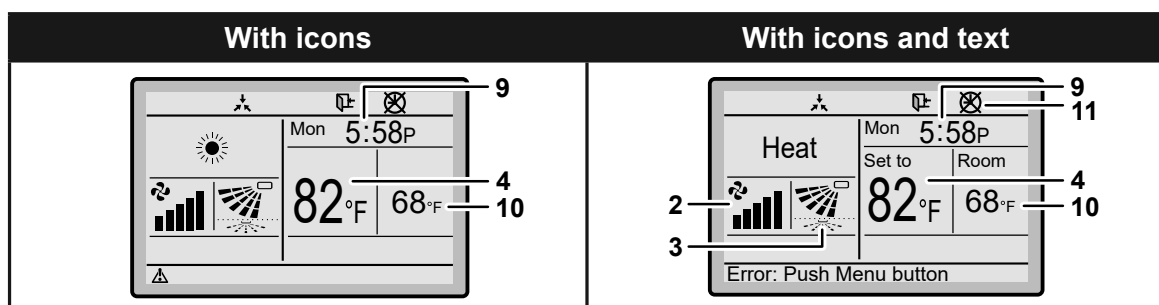

Detailed display

- The clock and Detailed selection items appear on the Detailed display in addition to the items appearing on the Standard display.



1. Operation mode

- Indicates the current operation mode.

Operation Mode		
Cool	Heat	Auto (Heat)
		
Fan	Dry	Auto (Cool)
		

2. Fan speed

(See "Cool/Heat/Fan/Dry/Auto Operation" on page 12)

- Indicates the fan speed that is set for the air conditioner.
- The fan speed will not be displayed if the air conditioner does not have the fan speed control function.

3. Airflow direction

- Displayed only when the air conditioner is in operation.
- Indicates the airflow direction that is set for the air conditioner.
- The possible directions depend on the indoor unit.

4. Set/Setback temperature display

(See "Setback" on page 17)

- When the unit is turned ON, the temperature that is set for the air conditioner is displayed.
- When the unit is turned OFF and Setback is disabled, the temperature that is set for the air conditioner is displayed.
- When the unit is turned OFF and Setback is enabled, the temperature that is set for the setback function is displayed in smaller digits.

5. Error "▲"

(See "Error Code Display" on page 42)

- Indicates a unit error.

6. Timer enabled "☺"

(See "OFF Timer" on page 27 and "Schedule" on page 28)

- Indicates that the schedule timer or the OFF timer is enabled.

7. Under Centralised control "✱"

- Indicates that the air conditioner is under the management of central control equipment (optional accessories) and the operation of the system through the remote controller is prohibited.

8. Setback "⏮"

(See "Setback" on page 17)

- The setback icon flashes when the unit is turned on under the setback control.

9. Clock (12/24 hours real time clock)

(See "Clock & Calendar" on page 38)

- Indicates that the clock is set.
- If the clock is not set, "-- : --" will be displayed.

10. Detailed selection



(See "Display Mode" on page 34)

- Displayed when the detailed display mode is selected.
- No detailed items are selected by default.

11. Timer problem "⌛"

- Indicates that the clock needs to be set again.
- The schedule timer function will not work unless the clock is set again.

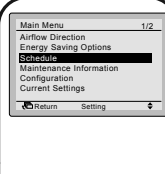
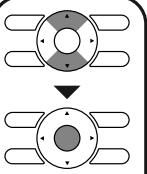
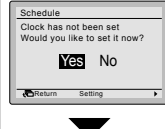
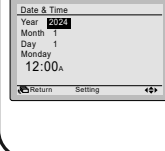
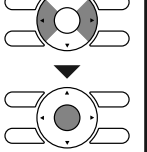
Basic Operation Method

Remote Controller Functions	Operation procedure	Button display
Screen display Screens that will be displayed on the remote controller.	Operation Method	Displays the positions of the buttons to be operated.
1 	<ul style="list-style-type: none"> • Display the Main Menu. (See "Manipulating the Main Menu" on page 21). • Press the ▼▲ (Up/Down) buttons to select Schedule and press the Menu/Enter button. 	
2  	<ul style="list-style-type: none"> • Press the ◀▶ (Left/Right) buttons to select Yes and press the Menu/Enter button. • The Date & Time screen will appear. • Set the current year, month, day, and time. (See "Clock & Calendar" on page 38). <p>Note</p> <ul style="list-style-type: none"> • Before setting the schedule, the clock must be set. • If the clock has not been set, a screen like the one on the left will appear. 	 

Enable/disable the Menu/Enter and Cancel button

Operation Method By default, the Menu/Enter and Cancel button are enabled.

1

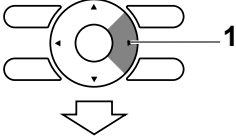

- To enable/disable the Menu/Enter and Cancel button, keep the ► (Right) button pressed in the Basic Screen.

2

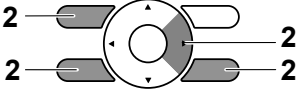

- Press the 3 keys simultaneously while keeping the ► (Right) button pressed.

Cool/Heat/Fan/Dry/Auto Operation

Operation Method

1

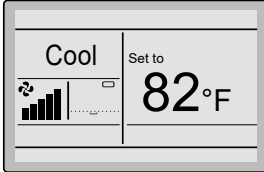

- Press the Operation Mode Selector button several times until the desired mode (Cooling, Heating, Fan Only, Dry or Auto) is selected.



Note

- Unavailable operation modes are not displayed.
- Only Cooling, Dry or Fan Only mode can be selected if the air conditioner is a cooling-only model.

2

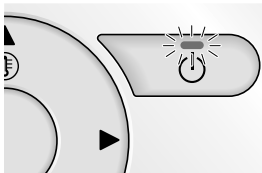

- Press the ON/OFF button. The Operation lamp (green) will be lit and the air conditioner will start operating.



3

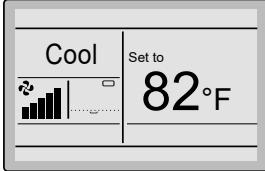

- The set temperature will increase by 1°F when the ▲ (Up) button is pressed and decrease by 1°F when the ▼ (Down) button is pressed.

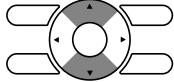

Note

Temperature settings are not possible while in Dry or Fan Only mode.

4

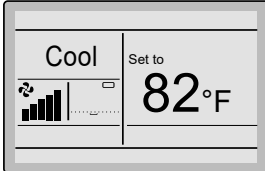

- To change the fan speed or airflow direction, press the Fan Speed/Airflow Direction button.



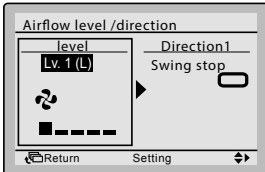

- To select air volume or airflow direction setting, press the ◀▶ buttons.
- Press the ▲▼ (Up/Down) buttons to select the desired level or position.

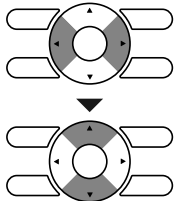

Basic Operation Method

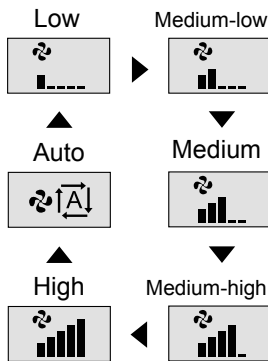

Note

- The air conditioner may be in automatic fan speed control for mechanical protection purposes.
- The air conditioner may be in automatic fan speed control according to the room temperature.
- The fan may stop operating, which is not a failure.
- It may take time until fan speed changes are actually carried out.
- In Auto fan speed, the fan speed is adjusted automatically according to the setpoint and indoor temperature.

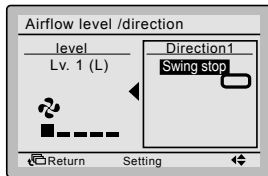

- With airflow direction selected, select the desired airflow direction from **Swing** or **Swing stop** using the ▲▼ (Up/Down) buttons.

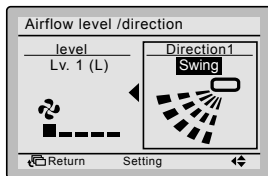

Airflow direction setting (up/down)

Note

- The airflow directions appear on the screen as follows:



Up/down direction



Left/right direction

- Selecting **Swing** will cause the airflow direction blades to swing back and forth.
- When you select **Swing stop**, the airflow direction blades stay in the position of when you press the Menu/Enter button.

Note

- To change the left/right airflow direction, refer to "Change the Airflow direction" on page 22.

Basic Operation Method

5

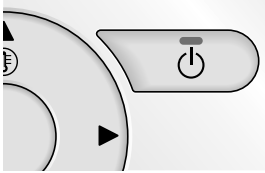

- When the ON/OFF button is pressed again, the air conditioner will stop operating and the Operation lamp will turn OFF.

**Note**

- When the system is stopped while in heating operation, the fan will continue to operate for approximately 1 minute in order to eliminate the residual heat in the indoor unit.

Characteristics of Cooling Operation

- When the outdoor air temperature is high, it takes some time until the room temperature reaches the set temperature.

Characteristics of Heating Operation

Starting operation

- Heating operation generally requires a longer time to attain the set temperature compared with cooling operation.
It is recommended to start operating the air conditioner in advance by using the timer.

Perform the following operation in order to prevent the degradation of the heating capability or cold drafts.

Defrost operation

- The air conditioner will automatically go into defrost operation to prevent frost accumulation at the outdoor unit which results in loss of the heating capacity.
- The air conditioner will return to normal operation after approximately 4 to 12 minutes.
- During defrost mode the temperature near the indoor room temp is displayed. This may be affected by the location of the unit.

Outdoor temperature and heating capability

- The heating capacity of the air conditioner will drop when the outdoor temperature decreases.
If the heating effect is insufficient, it is recommended to use another heating appliance in combination with the air conditioner. (When a combustion appliance is used, ventilate the room regularly).
Do not use the heating appliance in places where the heating appliance is exposed to the airflow of the air conditioner.
- The air conditioner is a hot air circulation type. Therefore, it takes some time to warm up the room after the air conditioner starts operating.
The indoor fan will automatically operate until the indoor temperature of the system rises to a certain level.
- If hot air stays around the ceiling and your feet feel cold, a circulator is recommended.
For details, consult your Daikin dealer.

Program Dry Operation

Preparation

- The dry mode may not be selected if the remote controller has no eligibility to select cooling/heating mode.

Operation Method

1



- Press the Operation Mode Selector button several times until Dry mode is selected.

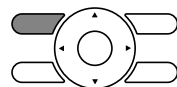

Note

Dry mode may not be available depending on the type of indoor unit.

2



- Press the ON/OFF button. The Operation lamp will be lit and the air conditioner will start operating.



Note

The air conditioner is in automatic temperature and fan speed control. Therefore, the temperature or fan speed cannot be changed while the air conditioner is in operation.

3

- To set the airflow direction, see "Airflow Direction" on page 22.

4

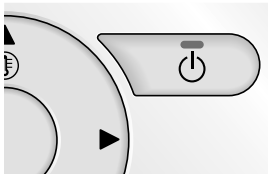

- When the ON/OFF button is pressed again, the air conditioner will stop operating and the Operation lamp will turn OFF.

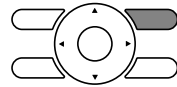

Note

To prevent water leakage or system failure, do not turn OFF the power soon after the air conditioner stops operating. Be sure to wait at least 5 minutes so that the drain pump finishes discharging the residual water from the indoor unit.

Basic Operation Method

Characteristics of Dry Operation

In Dry operation, the air humidity will be lowered by intermittently turning the air conditioner ON in cooling and OFF again to minimize the temperature decrease.

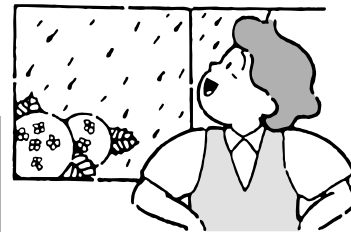

- Note**
- The temperature and fan speed are controlled automatically and cannot be controlled by the remote controller.
 - Dry operation will not function if the room temperature is too low.

Setback

The Setback function will maintain the room temperature in a specific range when the remote controller is turned OFF. This is done by temporarily starting the air conditioner that was previously turned OFF by the user, the schedule function or the OFF timer.

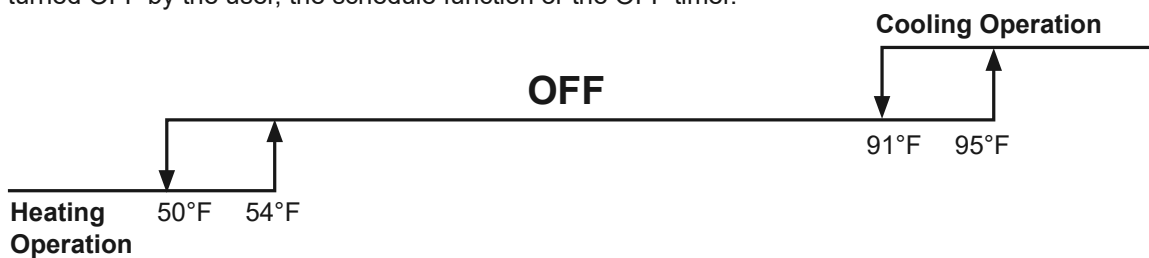

For example:

- [Setback setpoint temperature: cool 95°F, heat 50°F]
- [Recovery differential: cool -4°F, heat +4°F]

- If the room temperature drops below 50°F, heating is started automatically. If after half an hour the temperature increases to 54°F or above, the controller returns to its original state.
- If the room temperature goes above 95°F, cooling is started automatically. If after half an hour the temperature drops to 91°F or below, the controller returns to its original state.

- Note**
- This function is disabled by default. This function can only be enabled/disabled in the Energy Saving List (See "Energy Saving Options" on page 23).
 - The differential can be adjusted in the Setback Condition menu (See "Setback Condition" on page 25).
 - The setback temperature can be set while the unit is turned off on the Basic Screen or set in the schedule.
 - Setback will turn the unit ON for at least 30 minutes unless the setback temperature setpoint is changed or the unit is turned ON with the ON/OFF button.
 - When setback turns the air conditioner ON while in Auto mode, the remote controller switches to Cooling or Heating only, depending on what is appropriate, and only the respective setback temperature setpoint is shown.
 - The temperature is measured inside the air conditioner unit (when the unit is switched OFF). As there is no actual air flow, the measured temperature inside the air conditioner unit can deviate (up to 6°F) from the actual room temperature.

Setback should not be enabled when a centralised controller is connected via the KRP928 Interface adapter for Room Air Conditioner.

Operation Method

1

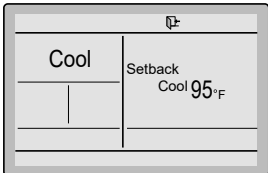

The setback icon "⏸" flashes when the unit is turned ON under the setback control.

The fan speed cannot be changed when setback is active and, as a result, the fan speed is not visible.

The airflow direction can only be changed through the menu when setback is active.

Key Lock

Operation Method

Disable the use of all buttons.

1

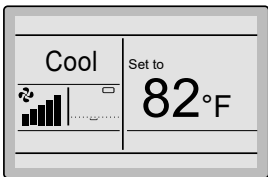

- Press the Menu/Enter button for at least 4 seconds. (During backlight lit)

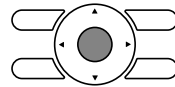

2

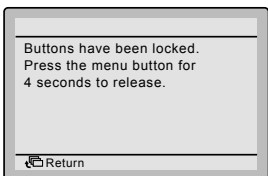

- All buttons are disabled when the keys are locked.
- When one of the buttons is pressed, the message on the left is displayed.

3

- To cancel the key lock, continue pressing the Menu/Enter button for at least 4 seconds. (During backlight lit)

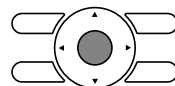

Quick Reference of Main Menu Items

■ Main Menu Items Overview

Note

- The available items may vary with the connected model.
- Only the available items will appear in the menu.

Setting and display items		Description	Reference page
Airflow Direction		Change the airflow direction. <ul style="list-style-type: none"> • The airflow direction blades can be automatically operated up and down and left and right. • There are swing or swing stop directions. • This function is not available on all models. 	22
Energy Saving Options⁽¹⁾	Energy Saving List	Enable or disable the "Energy Saving Options".	23
	Setpoint Range Setting	The setpoint temperature range can be restricted for the Cooling, Heating and Auto Mode.	24
	Setback Condition	Set the setback differential temperature after which the unit will turn back OFF.	25
	Setpoint Auto Reset	Change the temperature setpoint to a preset temperature setpoint after running for a set period of time, even if the temperature setpoint has been changed. <ul style="list-style-type: none"> • Possible to set from 30 to 120 minutes in 30 minute increments. 	26
	Off Timer	The system is turned off automatically after the selected time each time the system is activated. <ul style="list-style-type: none"> • Possible to set in 10 minute increments from 30 to 180 minutes. 	27
Schedule⁽²⁾	Enable/Disable	Enable or disable schedule function.	28
	Select Schedule	Select the active schedule number (schedule nr 1, 2 or 3).	29
	Holidays	Select the days of the week for which the schedule will be disabled. This function is used for when the schedule doesn't need to be active, e.g. like when you are on holiday.	30
	Schedule Settings	Select when the operation modes start and/or stop for each day of the week. Up to 5 actions can be set for each day.	31

1) Setback, Setpoint Range, Setback Condition and Setpoint Auto Reset should not be used when a centralised controller is connected via the KRP928 Interface adapter for Room Air Conditioner.

2) The schedule can be restricted when a centralised controller is connected via the KRP928 Interface adapter for Room Air Conditioner.

Quick Reference of Main Menu Items

Setting and display items		Description	Reference page
Maintenance Information		Display the service contact.	33
Configuration	Display	<ul style="list-style-type: none"> • Display: Switch between Standard or Detailed display. • Detailed display settings: Select if room temperature (near the indoor unit), outdoor temperature, or nothing is displayed. 	34
	Celsius / Fahrenheit	Choose the temperature values from Celsius or Fahrenheit.	36
	Contrast Adjustment	Adjust the LCD contrast.	36
Current Settings		Display a list of the current settings of the available items.	37
Clock & Calendar	Date & Time	Configure the date and time settings. <ul style="list-style-type: none"> • The default time display is 12H. • The clock will maintain accurate within ± 30 seconds per month. • If there is a power failure for a period not exceeding 48 hours, the clock will continue working with the built-in backup power supply. 	38
	12H/24H Clock	The time can be displayed in either a 12 hour or 24 hour time format.	39
	Daylight Saving Time	Enable or Disable the Daylight Saving Time.	39
Language		Choose the language from English, French or Spanish.	40

Menu Manipulation

Main Menu

■ Manipulating the Main Menu

Operation Method

1

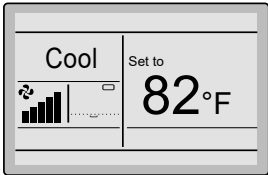

Basic Screen

- Press the Menu/Enter button.

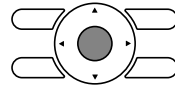

2

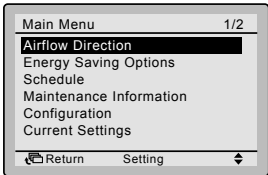

Main Menu

- The Main Menu will appear.

← Instructions for operating the buttons will appear.

3

- Selecting items from the Main Menu.
 1. Press the ▼▲ (Up/Down) buttons to select the desired item.
 2. Press the Menu/Enter button to display the selected settings screen.

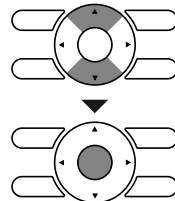

4

- To go back to the Basic Screen from the Main Menu, press the Cancel button.



⚠ Caution

- When the Main Menu is visible and a button is not pressed for 5 minutes, the screen will automatically go back to the Basic Screen.

Airflow Direction

Change the Airflow direction

Operation Method

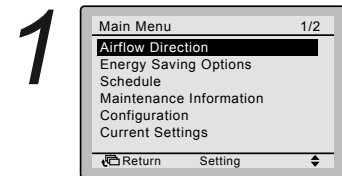

- Display the Main Menu (See "Manipulating the Main Menu" on page 21)
- Press the ▲▼ (Up/Down) buttons to select **Airflow Direction** and press the Menu/Enter button.

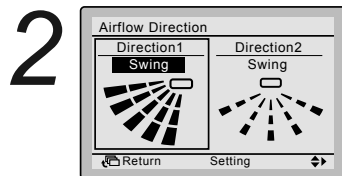
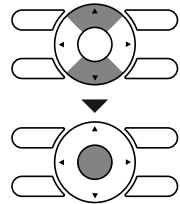

- Select the desired airflow direction from **Swing** or **Swing stop** using the ▲▼ (Up/Down) buttons.
- Select Up/down direction or Left/right direction using the ◀▶ (Left/Right) buttons.
- Press the Menu/Enter button to confirm the settings and to return to the Basic Screen.

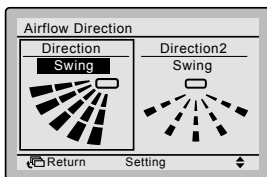
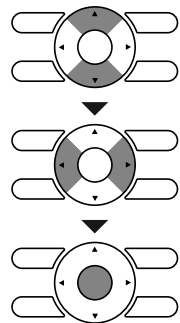

Airflow direction setting (up/down)

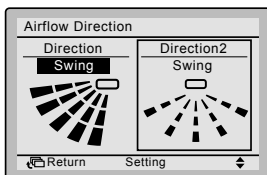

Airflow direction setting (left/right)

Remark: Only visible if available.

Note

- The airflow directions appear on the screen as follows:



Up/down direction



Left/right direction

- Selecting **Swing** will cause the airflow direction blades to swing back and forth. When **Swing** is selected, all airflow directions will be visible at the same time.
- When you select **Swing stop**, the airflow direction blades stay in the position that you press the Menu/Enter button.

Menu Manipulation

Energy Saving Options

■ Energy Saving List

Some functions should not be enabled when a centralised controller is connected via the KRP928 Interface adapter for Room Air Conditioner.

Operation Method

1

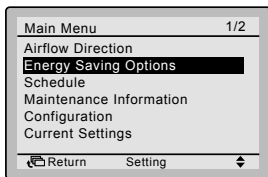

- Display the Main Menu. (See "Manipulating the Main Menu" on page 21).
- Press the ▼▲ (Up/Down) buttons to select **Energy Saving Options** and press the Menu/Enter button.

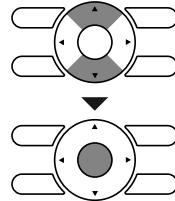

2

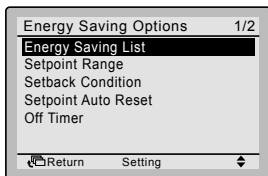

- Press the ▼▲ (Up/Down) buttons to select **Energy Saving List** and press the Menu/Enter button.

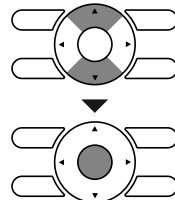

3

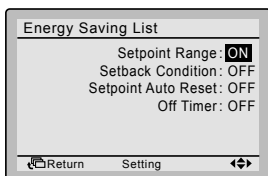

- Press the ▼▲ (Up/Down) buttons to change the setting to **ON** or **OFF**.
- Move the cursor using the ◀▶ (Left/Right) buttons.
- Press the Menu/Enter button when all changes are made. The confirmation screen will appear.

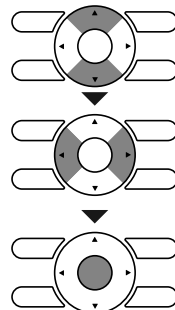

4

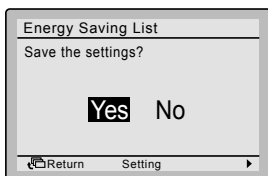

- Press the ◀▶ (Left/Right) buttons to select **Yes**.
- Press the Menu/Enter button to confirm the settings and to return to the Basic Screen.

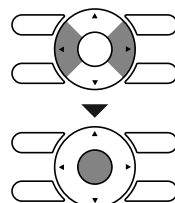

■ Setpoint Range Setting

Operation Method

This function should not be used when a centralised controller is connected via the KRP928 Interface adapter for Room Air Conditioner.

1

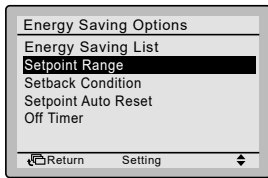

- Display the Energy Saving Options (See "Energy Saving List" on page 23).
- Press the ▼▲ (Up/Down) buttons to select **Setpoint Range** and press the Menu/Enter button.

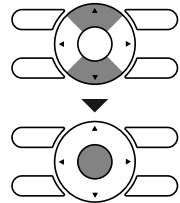

2

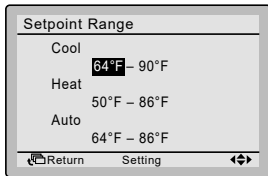

- Press the ▼▲ (Up/Down) buttons to change the cooling or heating temperature setpoint range.
- Move the cursor using the ◀▶ (Left/Right) buttons.
- Press the Menu/Enter button when all changes are made. The confirmation screen will appear.

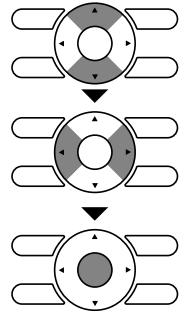

Note

- The default setpoint range restriction is [64°F→90°F] for cooling, [50°F→86°F] for heating, and [64°F→86°F] for auto. This setpoint range is the general setpoint range and is as a result always active regardless of whether Setpoint Range is enabled or disabled.
- The default setpoint range for setback operation is [92°F→99°F] for cooling and [50°F→59°F] for heating. This setpoint range cannot be changed.

3

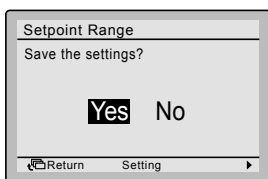

- Press the ◀▶ (Left/Right) buttons to select **Yes**.
- Press the Menu/Enter button to confirm the settings and to return to the Basic Screen.

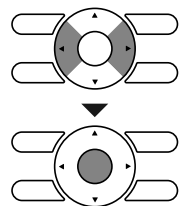

Menu Manipulation

■ Setback Condition

This function should not be used when a centralised controller is connected via the KRP928 Interface adapter for Room Air Conditioner.

Operation Method

1

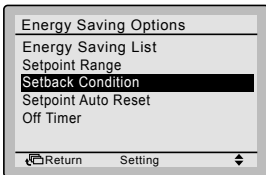

- Display the Energy Saving Options (See "Energy Saving List" on page 23).
- Press the ▼▲ (Up/Down) buttons to select **Setback Condition** and press the Menu/Enter button.

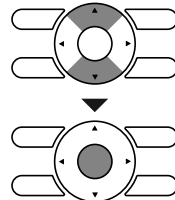

2

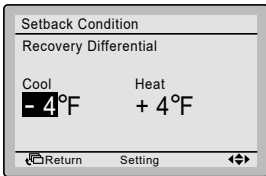

- Press the ▼▲ (Up/Down) buttons to change the differential for setback operation.
- Move the cursor using the ◀▶ (Left/Right) buttons.
- Press the Menu/Enter button when all changes are made. The confirmation screen will appear.

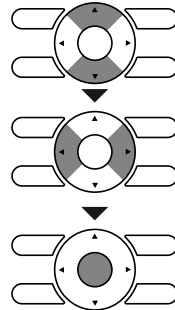

3

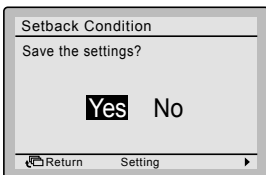

- Press the ◀▶ (Left/Right) buttons to select **Yes**.
- Press the Menu/Enter button to confirm the settings and to return to the Basic Screen.

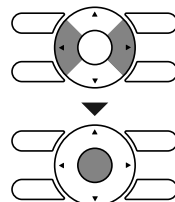

■ Setpoint Auto Reset

This function should not be used when a centralised controller is connected via the KRP928 Interface adapter for Room Air Conditioner.

Operation Method

1

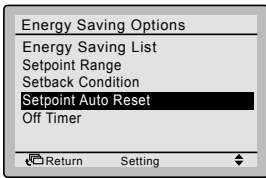

- Display the Energy Saving Options (See "Energy Saving List" on page 23).
- Press the ▼▲ (Up/Down) buttons to select **Setpoint Auto Reset** and press the Menu/Enter button.

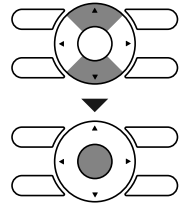

2

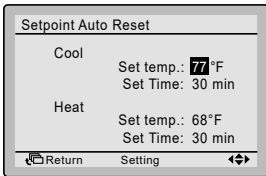

- Press the ▼▲ (Up/Down) buttons to set the preset temperature and timing for the auto reset of the setpoint.
- Move the cursor using the ◀▶ (Left/Right) buttons.
- Press the Menu/Enter button when all the changes are made. The confirmation screen will appear.

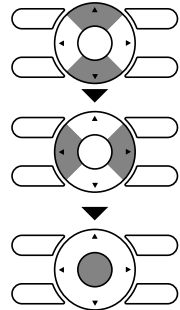

3

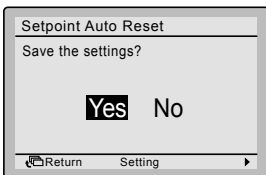

- Press the ◀▶ (Left/Right) buttons to select **Yes**.
- Press the Menu/Enter button to confirm the settings and to return to the Basic Screen.

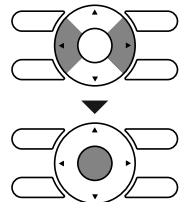

Menu Manipulation

OFF Timer

Operation Method

1

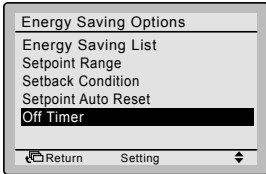

- Display the Energy Saving Options (See "Energy Saving List" on page 23).
- Press the ▼▲ (Up/Down) buttons to select **Off Timer** and press the Menu/Enter button.

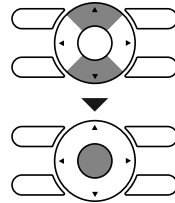

2

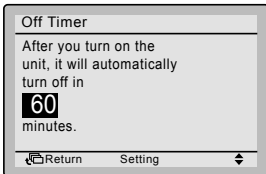

- Use the ▼▲ (Up/Down) buttons to set the time after which the unit automatically turns off again. Selections can be made in increments of 10 minutes from 30 to 180 minutes. Holding down the button causes the number to change continuously. The settings confirmation screen will appear when the Menu/Enter button is pressed.

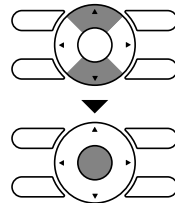

3

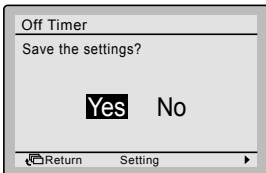

- Press the ◀▶ (Left/Right) button to select **Yes**.
- Press the Menu/Enter button to confirm the settings and to return to the Basic Screen.

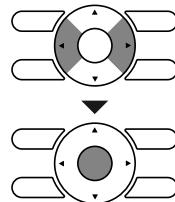

Schedule

■ Enable/Disable

The schedule can be restricted when a centralised controller is connected via the KRP928 Interface adapter for Room Air Conditioner.

Operation Method

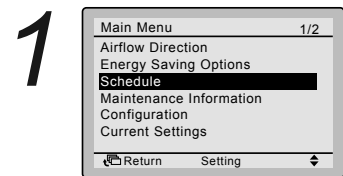

- Display the Main Menu. (See "Manipulating the Main Menu" on page 21).
- Press the ▼▲ (Up/Down) buttons to select **Schedule** and press the Menu/Enter button.

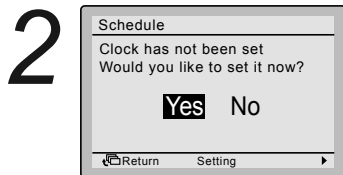
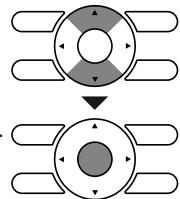

- Note**
- Before setting the schedule, the clock must be set.
 - If the clock has not been set, a screen like the one on the left will appear.

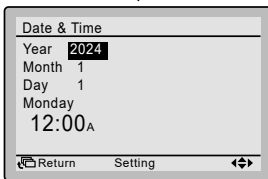

- Press the ◀▶ (Left/Right) buttons to select **Yes** and press the Menu/Enter button.
- The Date & Time screen will appear.
- Set the current year, month, day and time. (See "Clock & Calendar" on page 38).

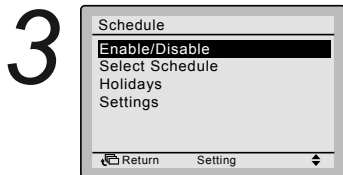
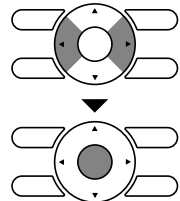

- Press the ▼▲ (Up/Down) buttons to select **Enable/Disable** and press the Menu/Enter button.

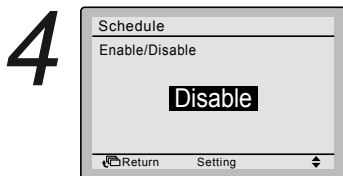
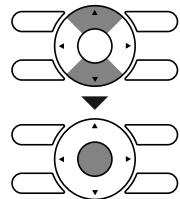

- Press the ▼▲ (Up/Down) buttons to select **Enable** or **Disable**.
- The confirmation screen will appear when the Menu/Enter button is pressed.

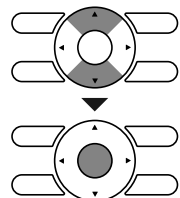

- Note**
- The Schedule is enabled. To modify the Selected schedule number see "Select Schedule" on page 29.

Menu Manipulation

5

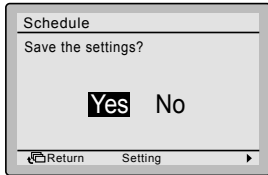

- Press the ◀▶ (Left/Right) buttons to select **Yes**.
- Press the Menu/Enter button to confirm the settings and to return to the Basic Screen.

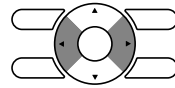

■ Select Schedule

Operation Method

It is possible to program up to three different schedules.

1

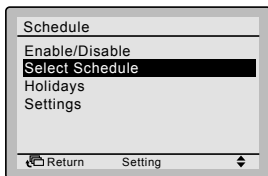

- Display the Schedule menu. (See "Enable/Disable" on page 28).
- Press the ▼▲ (Up/Down) buttons to select **Select Schedule** and press the Menu/Enter button.

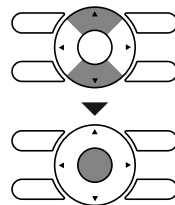

2

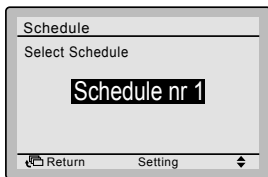

- Press the ▼▲ (Up/Down) buttons to select **Schedule nr 1**, **Schedule nr 2** or **Schedule nr 3**.
- The confirmation screen will appear when the Menu/Enter button is pressed.

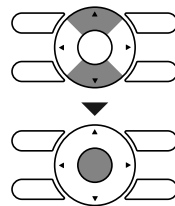

3

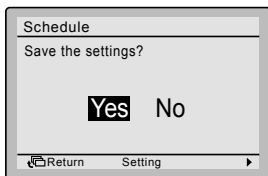

- Press the ◀▶ (Left/Right) buttons to select **Yes**.
- Press the Menu/Enter button to confirm the settings and to return to the Basic Screen.

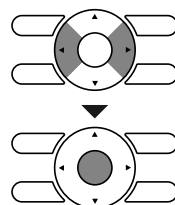

■Holidays

Operation Method The schedule timer will be disabled for days that have been set as a holiday.

1

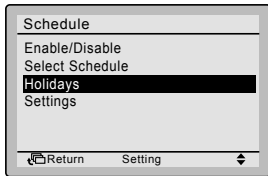

- Display the Schedule menu. (See "Enable/Disable" on page 28).
- Press the ▼▲ (Up/Down) buttons to select **Holidays** and press the Menu/Enter button.

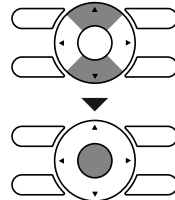

2

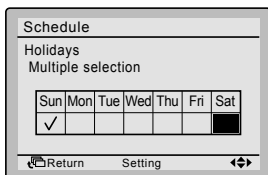

- Press the ◀▶ (Left/Right) buttons to select the desired day.
- Press the ▼▲ (Up/Down) buttons to display "✓" to set this day as a holiday.

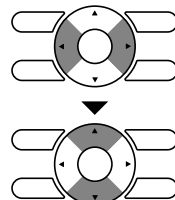

Note

- Multiple days can be selected as holidays.
- To re-enable the schedule timer for the day selected as a holiday, the holiday setting must be released.

3

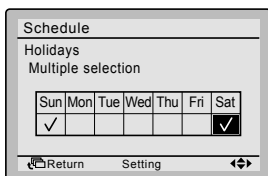

- Press the Menu/Enter button when all changes are made. The settings confirmation screen will appear.

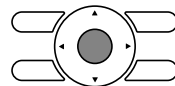

4

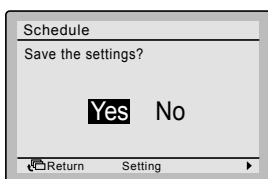

- Press the ◀▶ (Left/Right) button to select **Yes**.
- Press the Menu/Enter button to confirm the settings and to return to the Basic Screen.

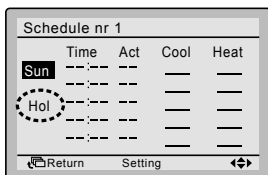
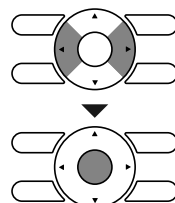

Note

"Hol" will be displayed on the schedule settings screen for days that have been set as a holiday.

Menu Manipulation

■ Schedule Settings

Operation Method After saving a schedule, the schedule is automatically enabled.

1

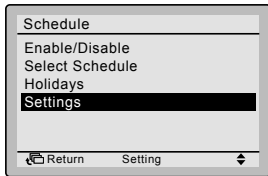

- Display the Schedule menu. (See "Enable/Disable" on page 28).
- Press the ▼▲ (Up/Down) buttons to select **Settings** and press the Menu/Enter button.

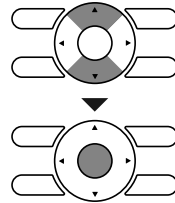

Note

The Schedule Settings of the selected schedule can be modified. To modify the selected schedule see "Select Schedule" on page 29.

2

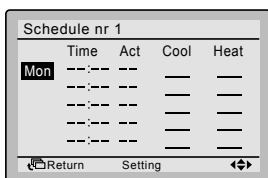

- Press the ▼▲ (Up/Down) buttons to select the day to be set.

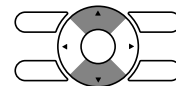

3

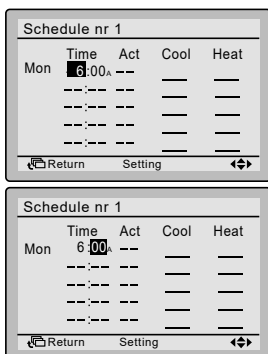

- Set the time for the selected day.
- Press the ◀▶ (Left/Right) buttons to move the highlighted item and press the ▼▲ (Up/Down) buttons to input the desired operation start time. Each press of the ▼▲ (Up/Down) buttons moves the numbers by 1 hour or 1 minute.

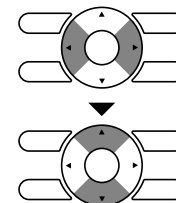

4

Schedule nr 1				
	Time	Act	Cool	Heat
Mon	6:00	---	---	---
	--:--	---	---	---
	--:--	---	---	---
	--:--	---	---	---

Schedule nr 1				
	Time	Act	Cool	Heat
Mon	6:00	ON	74°F	69°F
	--:--	---	---	---
	--:--	---	---	---
	--:--	---	---	---

Schedule nr 1				
	Time	Act	Cool	Heat
Mon	6:00	ON	74°F	69°F
	8:00	OFF	95°F	52°F
	--:--	---	---	---
	--:--	---	---	---

- Press the ◀▶ (Left/Right) buttons to move the highlighted item and press the ▼▲ (Up/Down) buttons to configure ON/OFF/-- settings.

"Act"-column:

- ON : The temperature setpoints can be configured.
- OFF : The setback temperature setpoints can be configured.
- : The temperature and setback temperature setpoints will be disabled.

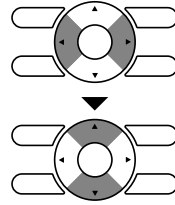

- Press the ◀▶ (Left/Right) buttons to move the highlighted item and press the ▼▲ (Up/Down) buttons to input the cooling and heating temperature setpoints for ON or OFF (Setback) operation.

"Cool" and "Heat" column:

- " _ " : Indicates that the temperature and setback temperature setpoint for this time period is not specified. The last active setpoint will be utilized.
- "- -" : Indicates that the setback function is disabled for this time period.

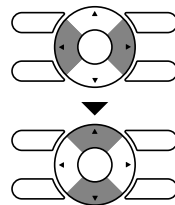

5

Schedule nr 1				
	Time	Act	Cool	Heat
Mon	6:00	ON	74°F	69°F
	8:00	OFF	95°F	52°F
	5:30	ON	74°F	69°F
	10:00	---	---	---
	--:--	---	---	---

Schedule nr 1				
	Time	Act	Cool	Heat
Mon	6:00	ON	74°F	69°F
	8:00	OFF	95°F	52°F
	5:30	ON	74°F	69°F
	10:00	OFF	95°F	52°F
	--:--	---	---	---

Schedule nr 1				
	Time	Act	Cool	Heat
Tue	6:00	ON	74°F	69°F
	8:00	OFF	95°F	52°F
	5:30	ON	74°F	69°F
	10:00	OFF	95°F	52°F
	--:--	---	---	---

Note
A maximum of 5 actions per day can be set.

- Press the Menu/Enter button when all changes are made. The confirmation screen will appear.

Note
To copy the settings from the previous day, press the Operation Mode Selector button.
Example: To copy the contents of Monday to Tuesday, select Tuesday and press the Operation Mode Selector button.

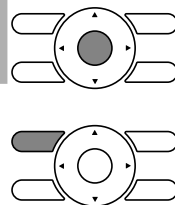

Menu Manipulation

6

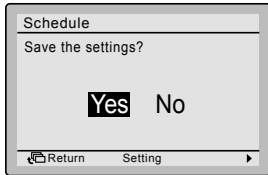

- Press the ◀▶ (Left/Right) buttons to select **Yes**.
- Press the Menu/Enter button to confirm the settings and to return to the Basic Screen.

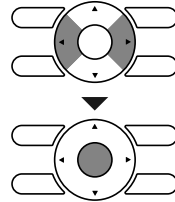

Maintenance Information

■ Display the Maintenance Information

Operation Method

1

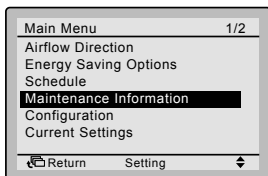

- Display the Main Menu. (See "Manipulating the Main Menu" on page 21).
- Press the ▼▲ (Up/Down) buttons to select **Maintenance Information** and press the Menu/Enter button.

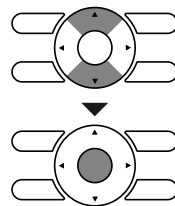

2

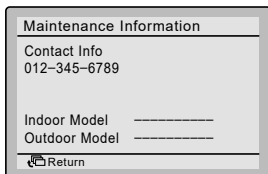

- The phone number for the contact address will appear at the top of the screen. (If you have not yet registered your product, it will not appear).
- The model information of the indoor and outdoor units of your product will always show -----.
- Press the Cancel button to return to the previous screen.



Note

- The error code may also appear. If the operation lamp is not blinking, the unit is working properly.
- The error code record will disappear if you press the ON/OFF button for more than 4 seconds.



Configuration

■ Display

Display Mode

Operation Method

1

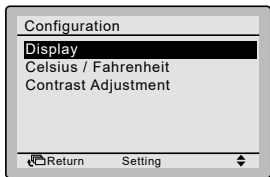

- Display the Configuration menu.
- Press the ▼▲ (Up/Down) buttons to select **Display** and press the Menu/Enter button.

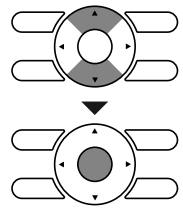

2

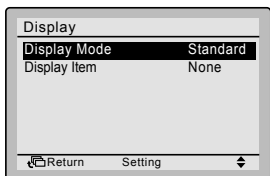

- Press the ▼▲ (Up/Down) buttons to select **Display Mode** and press the Menu/Enter button.

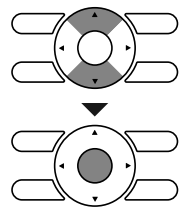

3

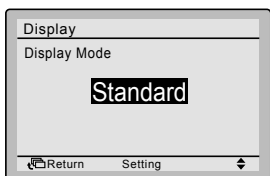

- Press the ▼▲ (Up/Down) buttons to select **Standard** or **Detailed**.
- Press the Menu/Enter button to confirm the settings and to return to the Basic Screen.

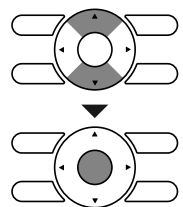

Note

To select which item is displayed in the detailed display selection area, refer to "Detailed Item" on page 35.

Menu Manipulation

Detailed Item

Operation Method

1

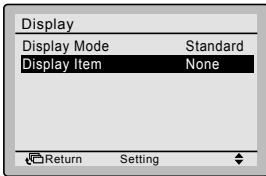

- Display the Display menu. (See "Display Mode" on page 34).
- Press the ▼▲ (Up/Down) buttons to select **Display Item** and press the Menu/Enter button.

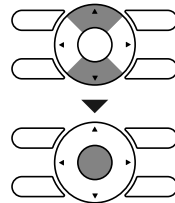

2

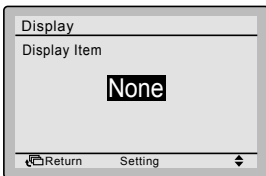

- Press the ▼▲ (Up/Down) buttons to display the following.

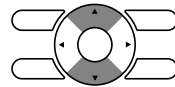
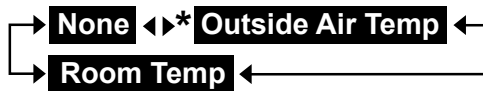

* Some models may not display these items even if they are selected.

- Be sure to read the following regarding the display of the room and outdoor temperature.

Room Temp

- The temperature near the indoor unit.
- The temperature that is detected may be affected by the location of the unit.

Outside Air Temp

- The temperature detected near the outdoor unit.
- The temperature that is detected may be affected by factors such as the location of the unit (e.g. if it is in direct sunlight) and unit operation during defrosting.
- "Outside Air Temp" will not display after stopping or immediately after starting.

- Press the Menu/Enter button to confirm the settings and to return to the Basic Screen.

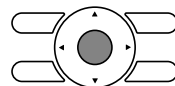

■ Celsius / Fahrenheit

Operation Method

1

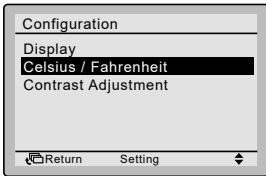

- Display the Configuration menu.
- Press the ▼▲ (Up/Down) buttons to select **Celsius / Fahrenheit** and press the Menu/Enter button.

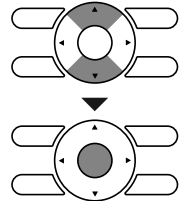

2

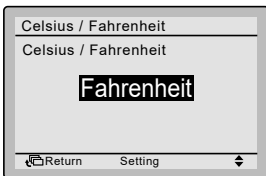

- Press the ▼▲ (Up/Down) buttons to select **Fahrenheit** or **Celsius**.
- Press the Menu/Enter button to confirm the settings and to return to the Basic Screen.

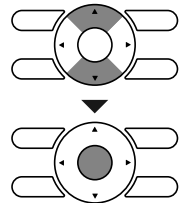

■ Contrast Adjustment

Operation Method

1

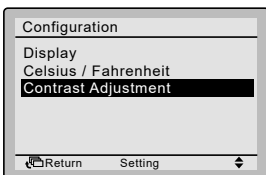

- Display the Configuration menu.
- Press the ▼▲ (Up/Down) buttons to select **Contrast adjustment** and press the Menu/Enter button.

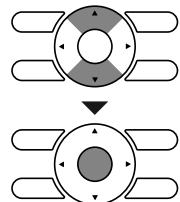

2

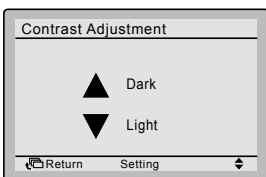

- Press the ▼▲ (Up/Down) buttons until you reach the desired contrast.
- Press the Menu/Enter button to confirm the setting and to return to the Basic Screen.

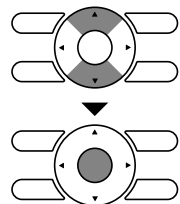

Menu Manipulation

Current Settings

Overview of the Current Settings

Operation Method

1

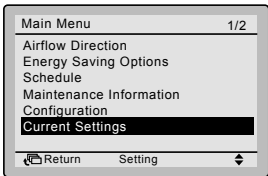

- Display the Main Menu. (See "Manipulating the Main Menu" on page 21).
- Press the ▼▲ (Up/Down) buttons to select **Current Settings** and press the Menu/Enter button.

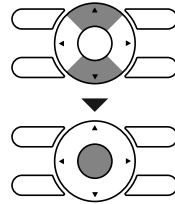

2

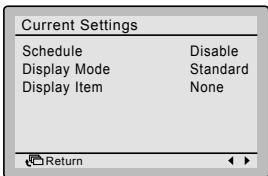

- A list showing the status of the current settings will appear.
- Press the Cancel button to return to the Main Menu.



Display items		
Schedule	Display Mode	Display Item

* Display items may differ depending on the model. Only the items that can be set are displayed.

Clock & Calendar

■ Date & Time

Operation Method

1

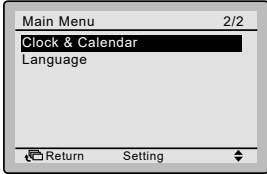

- Display the Main Menu. (See "Manipulating the Main Menu" on page 21).
- Press the ▼▲ (Up/Down) buttons to select **Clock & Calendar** and press the Menu/Enter button.

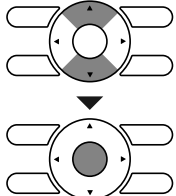

2

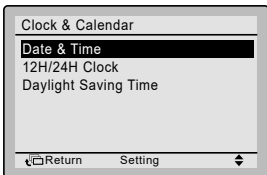

- Press the ▼▲ (Up/Down) buttons to select **Date & Time** and press the Menu/Enter button.

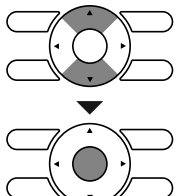

3

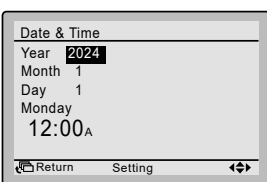

- Use the ▼▲ (Up/Down) buttons to change the date and time.
- Move the cursor using the ◀▶ (Left/Right) buttons.
- Press the Menu/Enter button when all changes are made. The confirmation screen will appear.

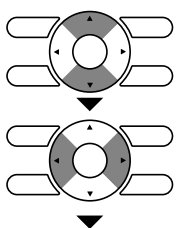

⚠ Caution

- By default, Daylight Saving Time (DST) is active. The following rules apply:
 - Start: Second Sunday of March 2:00 am
 - End: First Sunday of November 2:00 am
- Please consult your Daikin dealer if the DST settings need to be changed.

Note

The day of the week is set automatically.

4

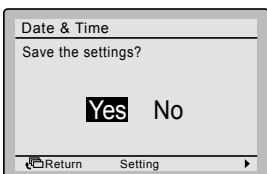

- Press the ◀▶ (Left/Right) button to select **Yes**.
- Press the Menu/Enter button to confirm the settings and to return to the Basic Screen.

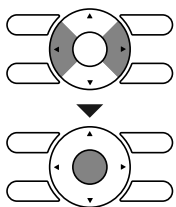

Menu Manipulation

■ 12H/24H CLOCK

Operation Method

1

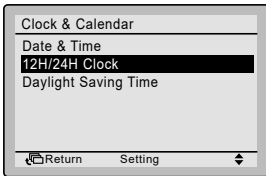

- Display the Clock & Calendar menu. (See "Date & Time" on page 38).
- Press the ▼▲ (Up/Down) buttons to select **12H/24H Clock** and press the Menu/Enter button.

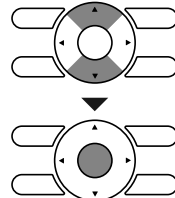

2

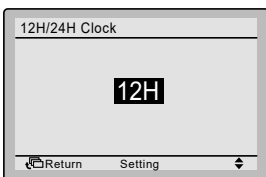

- Press the ▼▲ (Up/Down) buttons to select **12H** or **24H**.
- The confirmation screen will appear when the Menu/Enter button is pressed.

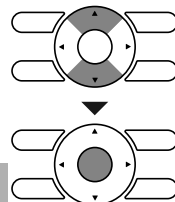

Note

By default, the time display is set to the 12H format.

3

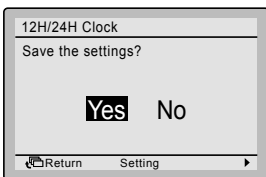

- Press the ◀▶ (Left/Right) buttons to select **Yes**.
- Press the Menu/Enter button to confirm the setting and to return to the Main Menu.

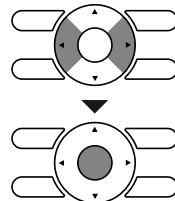

■ Daylight Saving Time

Operation Method

1

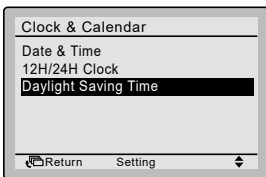

- Display the Clock & Calendar menu. (See "Date & Time" on page 38).
- Press the ▼▲ (Up/Down) buttons to select **Daylight Saving Time** and press the Menu/Enter button.

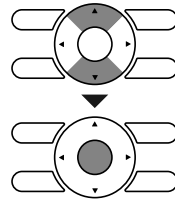

2



- Press ▼▲ (Up/Down) buttons to select **Enable** or **Disable**.
- Press Menu/Enter button to display the setting confirmation screen.

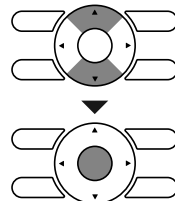

3

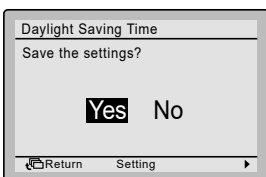

- Press the ◀▶ (Left/Right) buttons to select **Yes**.
- Press the Menu/Enter button to confirm the setting and to return to the Main Menu.

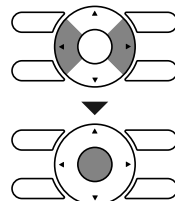

Language

■ Select the Language

Operation Method

1

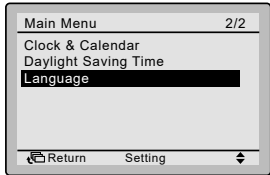

- Display the Main Menu. (See "Manipulating the Main Menu" on page 21).
- Press the ▼▲ (Up/Down) buttons to select **Language** and press the Menu/Enter button.

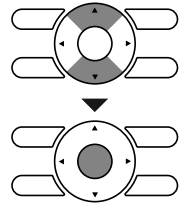

2

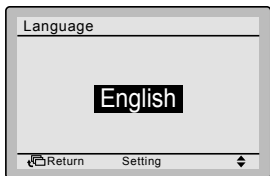

- Press the ▼▲ (Up/Down) buttons to select the preferred language (English, French or Spanish).
- Press the Menu/Enter button to confirm the settings and to return to the Basic Screen.

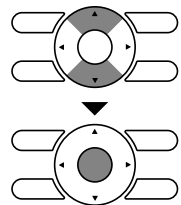

Maintenance

Caution

- **Do not wash the remote controller.**
Doing so may cause electric leakage and result in electric shocks or fire.



- **Be sure to stop the operation of the air conditioner and turn off the power supply breaker when performing maintenance activities.**



Failure to do so may result in electric shocks or injury.

Maintenance of Unit and the LCD display

Note:

- Wipe the LCD display and the rest of the surface of the remote controller with a dry cloth when they become dirty.
- If the dirt on the surface cannot be removed, soak the cloth in neutral detergent diluted with water, squeeze the cloth tightly, and clean the surface. Wipe the surface with a dry cloth afterwards.
- Do not use any paint thinner, organic solvent or strong acid.

Warning

Do not use flammable materials (e.g., hair spray or insecticide) near the air conditioner.

Do not clean the product with organic solvents such as benzine or paint thinner.

The use of organic solvents may cause crack damage to the product, electric shocks or fire.



Reference Information

Error Code Display

Contact your Daikin dealer in the following cases

Warning

When the air conditioner is malfunctioning (e.g., giving off a burning odor), stop the air conditioner and turn off the power.

Continued operation under such circumstances may result in failure, electric shocks or fire. Contact your Daikin dealer.



Operation Method

1

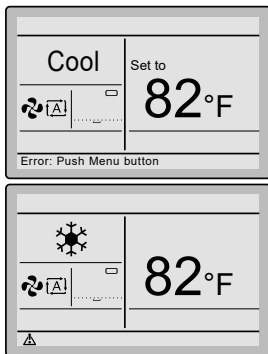

- If an error occurs, the error message or error icon and the operation lamp will blink.
- To display the error code and contact information, the Menu/Enter button needs to be enabled (See "Manipulating the Main Menu" on page 21).
- Press the Menu/Enter button.

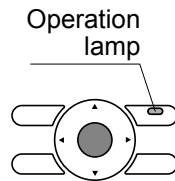

2

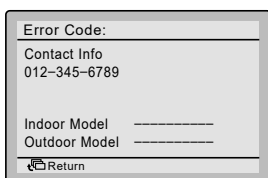

- The error code blinks and the contact address will appear.
- Notify your Daikin dealer of the Error code and Model name.

Reference Information

"Mode Conflict" message

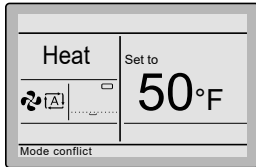

Only applicable in the case of multi systems (multiple indoor units connected to the outdoor unit) and for connected indoor units that support this functionality. When multiple indoor units are instructed to operate simultaneously, but in different operation modes, an operation mode conflict occurs:

- The operation lamp flashes
- **Mode conflict** appears on the user interface

• The units that do not have priority enter standby mode
 This is not a malfunction. To solve the conflict, make the units that do not have priority run in the same operation mode as that of the unit that has priority. Which unit has priority depends on whether the Priority Room setting is present and/or active:

If...	Then...
The Priority Room setting is present and active.	The operation mode of the indoor unit to which the Priority Room setting is applied takes priority. In case of an operation mode conflict, the other units will enter standby mode.

! NOTICE

- COOL, DRY and FAN operation can be used simultaneously.
- If the conflict is not solved manually, non-priority units will automatically resume operation as soon as the priority unit stops operating.

If...	Then...
The Priority Room setting is not present OR present but not active.	The operation mode of the indoor unit that was turned on first takes priority. In case of an operation mode conflict, the units that were turned on later will enter standby mode.

! NOTICE

- COOL, DRY and FAN operation can be used simultaneously.
- Units running in HEAT operation mode always have priority over units running in FAN operation mode, even if they were not turned on first.
- When solving the conflict, it is possible to make the non-priority units run in AUTO operation mode: they will automatically start operation in the same operation mode as that of the priority unit.

Caution

The **MODE CONFLICT** can also happen to units that are turned on by the **setback** function. This means that due to priority, they will not run and consequently will not be able to maintain the temperature in the room. Please consider the use of the **setback** feature in a multi system carefully to avoid situations like these.



Caution

When a KRP928 Interface adapter for Room Air Conditioner is connected, the mode conflict message will not be shown on the user interface, but the indoor unit will go into standby mode.



Combined use of the wired and wireless user interface

Avoid using the wired remote controller and the wireless remote controller at the same time.

- The wireless user interface does not receive feedback from the unit. When a setting is changed on the wired remote controller, the change is not communicated to the wireless remote controller.
- Since some functions of both controllers are not supported by each other, the displays will not match.

FCC Notice

This device complies with Part 15 of the FCC Rules. Operation is subject to the following two conditions:

- (1) This device may not cause harmful interference, and
- (2) This device must accept any interference received, including interference that may cause undesired operation.

CAN ICES-003(B)/NMB-003(B)

The FCC responsible party is Daikin Comfort Technologies Manufacturing, L.P., and may be contacted by calling (713)-861-2500, or at 19001 Kermier Rd., Waller, TX 77484. (<https://www.northamerica-daikin.com>)

NOTE: This equipment has been tested and found to comply with the limits for a Class B digital device, pursuant to part 15 of the FCC Rules. These limits are designed to provide reasonable protection against harmful interference in a residential installation. This equipment generates, uses and can radiate radio frequency energy and, if not installed and used in accordance with the instructions, may cause harmful interference to radio communications. However, there is no guarantee that interference will not occur in a particular installation. If this equipment does cause harmful interference to radio or television reception, which can be determined by turning the equipment off and on, the user is encouraged to try to correct the interference by one or more of the following measures:

- Reorient or relocate the receiving antenna.
- Increase the separation between the equipment and receiver.
- Connect the equipment into an outlet on a circuit different from that to which the receiver is connected.
- Consult the dealer or an experienced radio/ TV technician for help.

13.4 <BRC944B2> Wired Remote Controller (Installation)

⚠ CAUTION

1. No switch box or staple is supplied. Prepare them locally.
2. No remote controller cord is supplied. Prepare the optional remote controller cord 4 wire.
3. Be sure to turn off the power to any apparatus connected prior to mounting.
4. Prior to mounting equipment, touch something metallic such as a doorknob to remove static electricity from your body. Never touch the remote controller board or the adapter board.
5. Keep the wiring away from any other power source lines to avoid electric noise (external noise).
6. Select a flat surface, wherever possible, to mount the remote controller. To prevent deformation of the cases, do not overtighten the mounting screws.

1. Securing the remote controller lower case

Insert a bladed screwdriver into the concave (凹) in the remote controller lower case to remove the upper case assembly (two locations).

The remote controller board is located on the upper case. Take care not to scratch the board with the screwdriver.

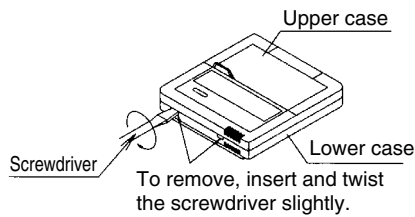

(1) Exposed mounting
Secure the remote controller lower case with the two supplied wood screws.

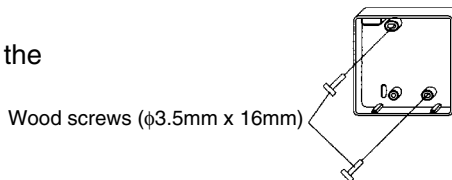

(2) Embedded mounting
Secure the remote controller lower case with the two supplied machine screws.

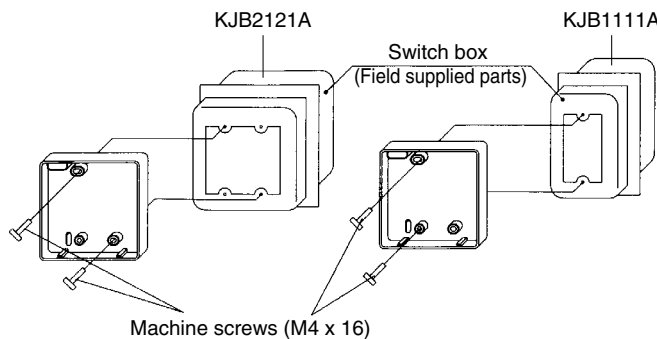

For the field supplied switch box, use optional accessories KJB1111A or KJB2121A.

2. Securing the remote control adapter

Remove the upper case of the remote control adapter and secure the lower case assembly.

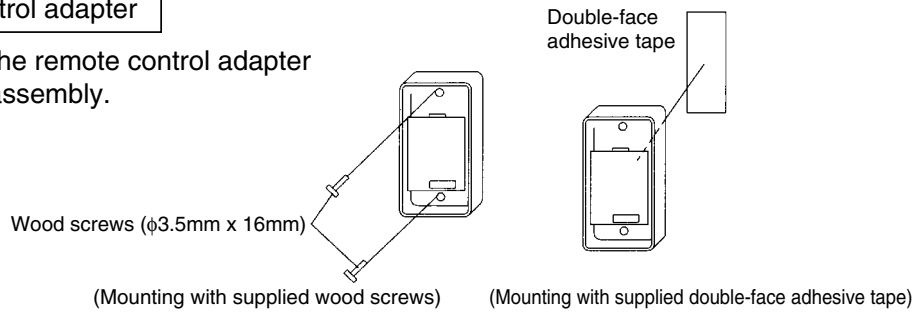

3. Wiring

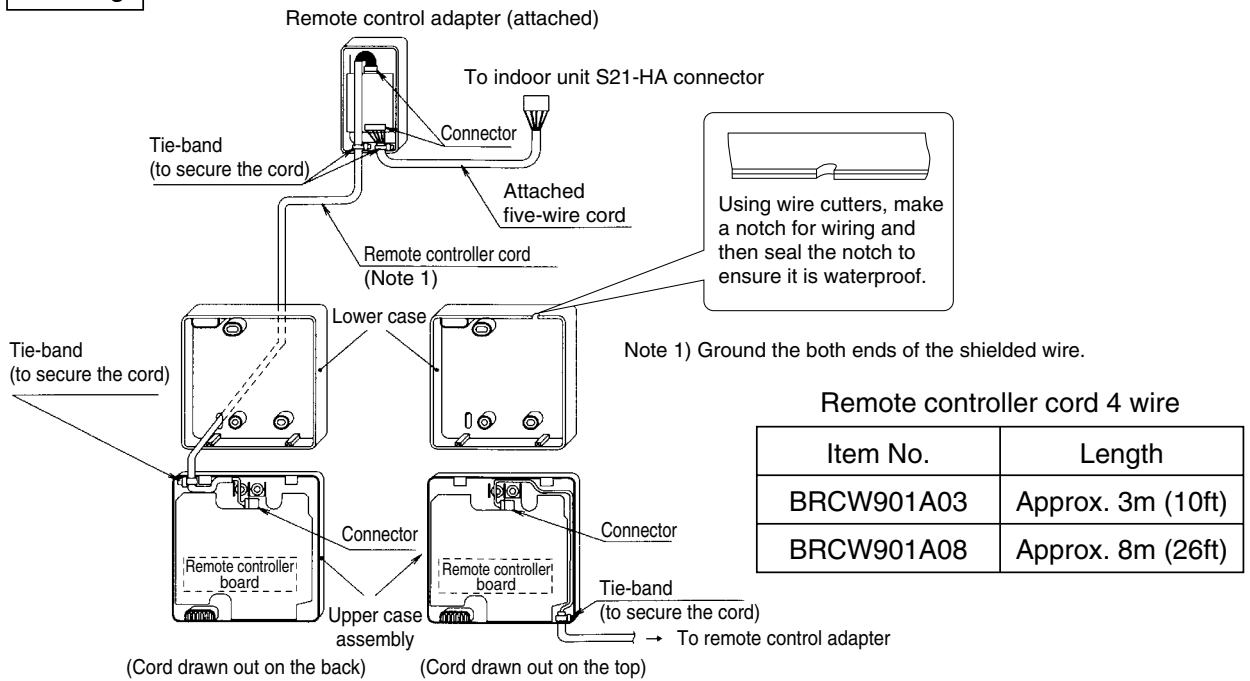

4. Placing the upper case assembly of the remote controller and the upper case of the remote controller adapter back into their original positions

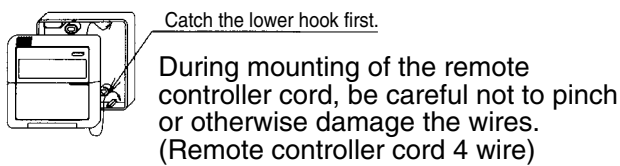

5. Temperature indication change

To change from Celsius temperature indication to Fahrenheit one

Press and hold down at the same time for 5 seconds while the Celsius temperature is indicated.

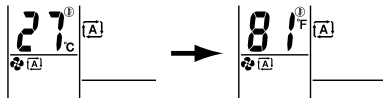

← See Operation Manual

13.5 <BRC944B2> Wired Remote Controller (Operation)

Controller Commands and their Corresponding Functions

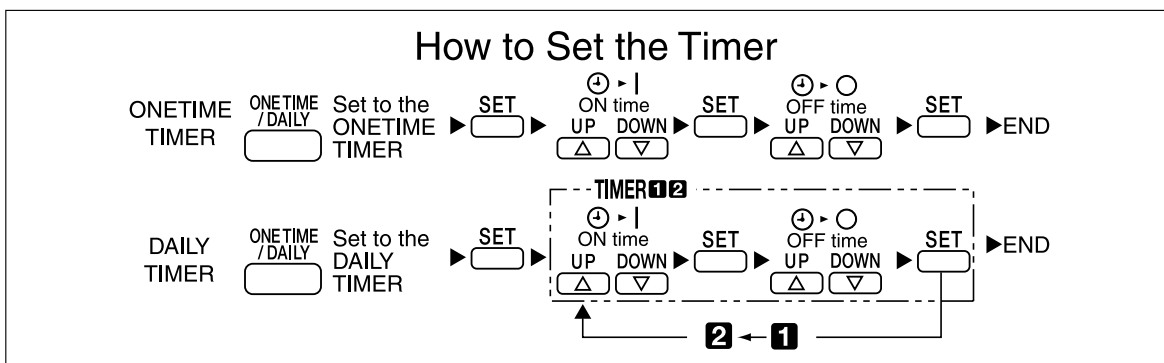
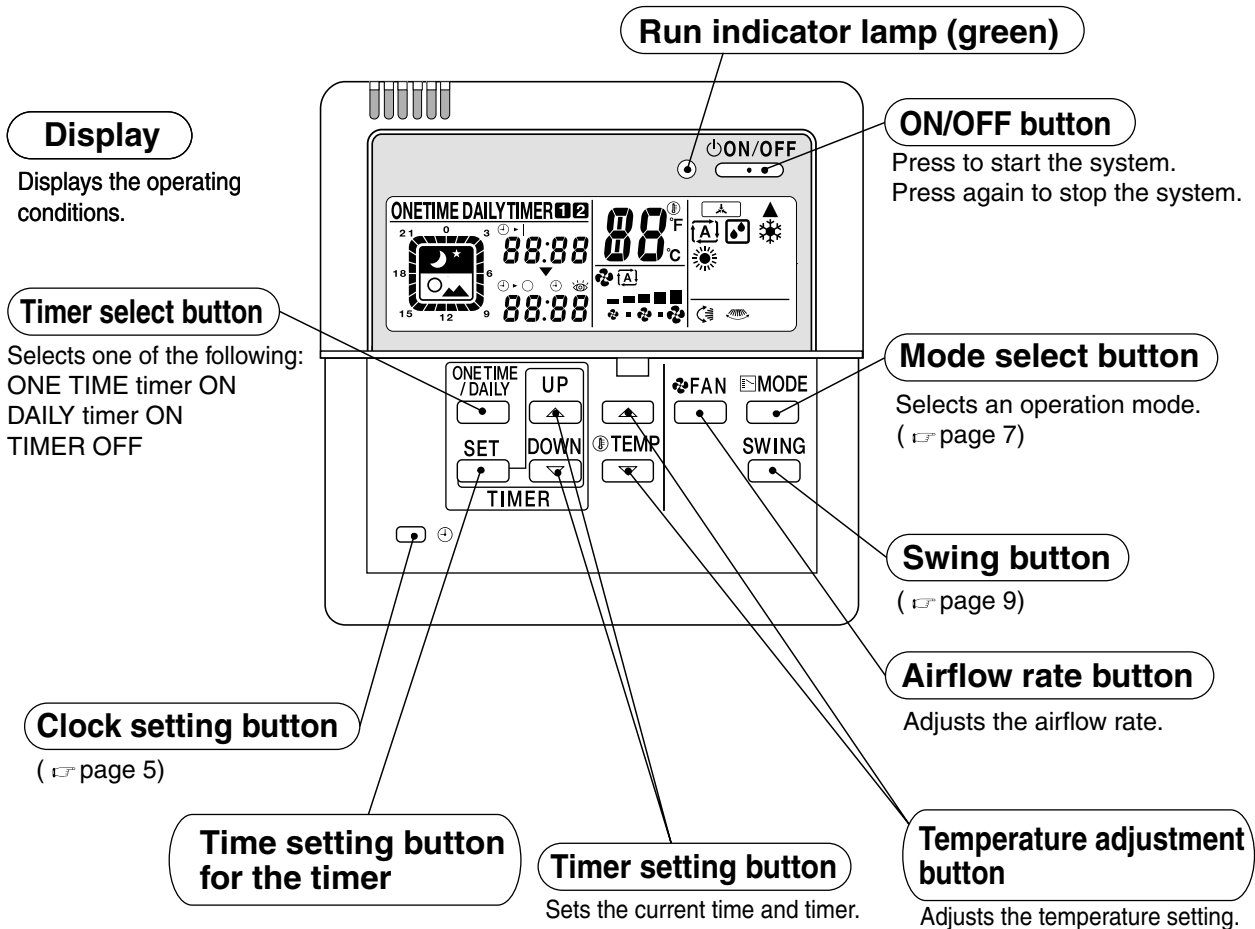

CAUTION

- This remote controller cannot be used together with a standard wireless remote controller. Otherwise, what appears on this remote controller's display may fail to correspond to actual operating conditions.

Preparation before Operation

■ Checking the power

If nothing appears on the remote controller's display, turn on the circuit breaker.

■ Setting the current time

1 Press .



The current time starts blinking.
0:00 lights up.

2 Press and set the current time.

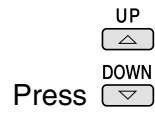

- Hold the button down to rapidly advance the time.

3 Press .

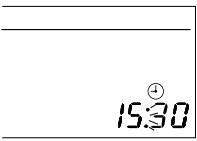

: blinks.
(This completes the current time setting)

- The clock's accuracy is ±30 seconds per month.

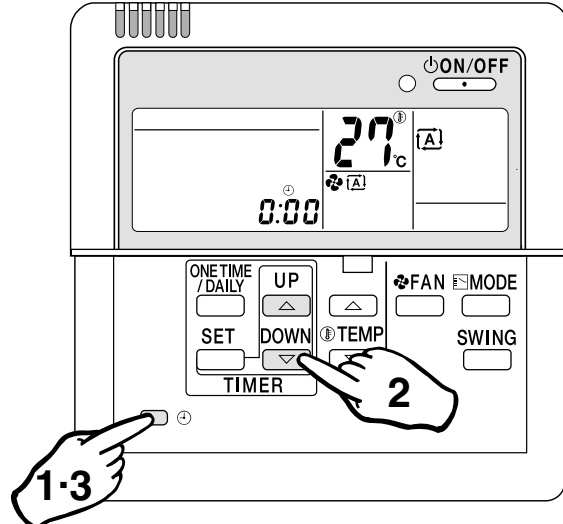

Notes

To use the unit efficiently

- Avoid overcooling or overheating. Moderate room temperature setting contributes to power saving.

Recommended temperature setting

For cooling 26~28°C (79°F~82°F)

For heating 20~22°C (68°F~72°F)
- Hang a blind or a curtain on the window. This will enhance the cooling/heating effect by intercepting direct sunlight and drafts.
- A clogged air filter reduces the cooling/heating effect and wastes energy. Clean the air filter monthly (every two weeks as required) or so.

Please take note of the following points

- Electric power is consumed even when the air conditioner is not in operation.
- When the unit is not used for a long period of time such as during off-season, turn off the breaker.

Operating conditions

- If the operation is continued under any conditions other than the following, the safety device may work to stop the operation. Also, dew may form on the indoor unit and drip from it. (Cooling/DRY)

Cooling	Outdoor temp.	-10 to 46°C (14°F to 115°F)
	Room temp.	18 to 32°C (64°F to 90°F)
	Indoor humidity	Less than 80%
DRY	Outdoor temp.	-10 to 46°C (14°F to 115°F)
	Room temp.	18 to 32°C (64°F to 90°F)
	Indoor humidity	Less than 80%
Heating	Outdoor temp.	-15 to 20°C (5°F to 68°F)
	Room temp.	Less than 27°C

- Operation limit differ according to the model.

Preparation before Operation

■ Setting Temperature Indication change

Temperature indication can be changed between Celsius and Fahrenheit before use.

To change from Celsius temperature indication to Fahrenheit one

- 1 Press and hold down  at the same time for 5 seconds while the Celsius temperature is indicated.

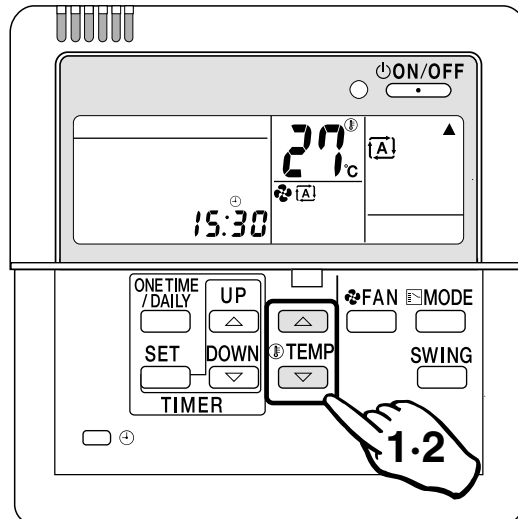
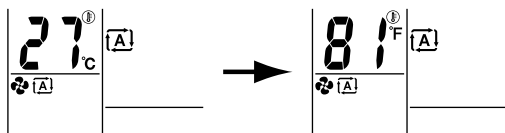

To change from Fahrenheit temperature indication to Celsius one

- 2 Press and hold down  at the same time for 5 seconds while the Fahrenheit temperature is indicated.

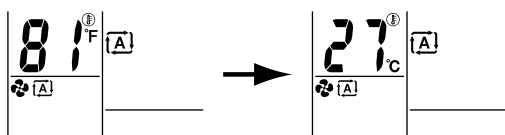

Notes

■ Temperature indication change between Celsius and Fahrenheit on the remote controller

- Change the temperature indication in the modes other than the DRY mode. In the DRY mode, temperature indication setting cannot be changed because the temperature is not indicated.
- When the Fahrenheit temperature indication is changed to Celsius one, the temperature value (0.5°C) will be rounded up. Thus, the preset temperature may be changed.

Example:

A preset temperature of 65°F (equivalent to 18.5°C) will be changed to 19°C (66°F) by changing the temperature indication. In this case, if you change the Celsius temperature indication again to the Fahrenheit one, the preset temperature is shown not as 65°F but as 66°F (equivalent to 19°C). If the preset temperature is 66°F (equivalent to 19°C) and is changed to the Celsius temperature indication, the indication becomes 19°C (66°F). In this case, no change by the temperature indication change is observed.

- When the temperature indication change is set, the preset temperature is transmitted to the indoor unit so that the reception sound will be heard from the indoor unit.

Automatic·DRY·Cooling·Heating Operation

Select your desired operation mode.

Once preset, the system can get restarted in the same operation mode.

1 Press  to select your desired operation mode.

- Each time the button is pressed, the mode changes as follows.

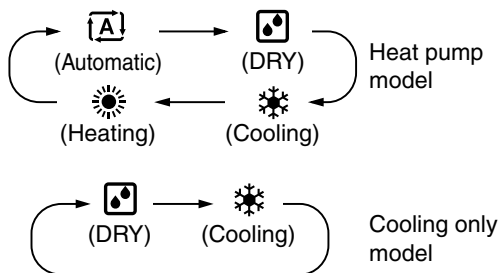

- The system does not have the FAN mode.

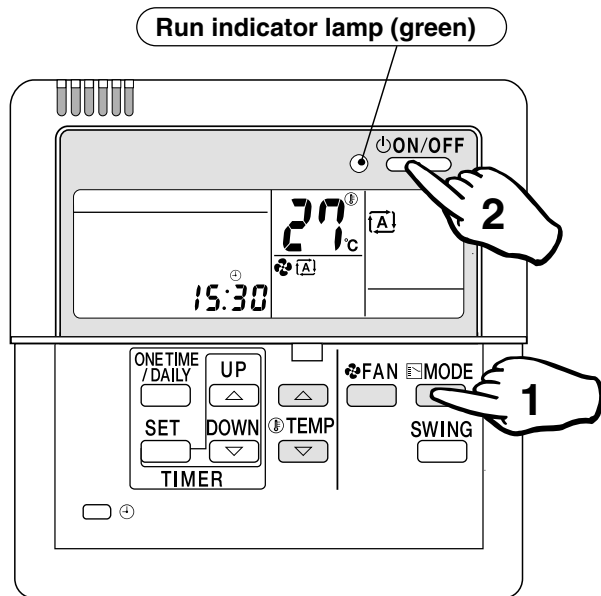

2 Press  .

The run indicator lamp lights up.

■ To stop the operation:

Press  again.

The run indicator lamp goes out.

Automatic operation

- In Automatic, the temperature setting and operation mode (DRY, Cooling or Heating) are automatically selected according to the room temperature and outdoor temperature at the time of starting operation.

DRY operation



- In this mode, humidity is removed from the air.



Note

- While running in the DRY mode, you may feel cool or warm air from the air outlet. In this case, readjust the airflow direction with the vertical airflow direction louvers. (except Duct Connected type)

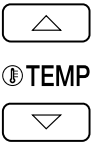
■ To adjust the temperature and airflow rate:

Operation mode Setting to be adjusted	Automatic	Cooling	Heating	DRY
 (Temperature)	Temperature is adjustable. Recommended temperature Cooling : 26°C-28°C (79°F~82°F) Heating : 20°C-22°C (68°F~72°F)			Temperature cannot be adjusted.
 (Airflow rate)	Five levels of airflow rate setting from " " to " " plus " [A] " are available. 			Airflow rate cannot be adjusted.

- When the unit runs in the cooling or heating mode at a low airflow rate, the cooling or heating effect may be insufficient.

■ To adjust the airflow direction:

(page 9)

Heating operation

- Since the heating operation is performed by taking the heat from outdoor into the room, the heating capacity decreases as the outdoor temperature lowers. If the room is not heated sufficiently, it is recommended to use other heating appliance at the same time.
- Since the air conditioner heats the whole room by circulating hot air, it takes some time to heat the entire room completely.
- If the outdoor unit gets frosted during heating operation, the heating capacity is decreased. In this case, the unit starts defrosting operation.
- No hot air comes out of the indoor unit during defrosting operation.

Adjusting Airflow Direction

Adjust the airflow direction for maximum comfort.

To adjust the Airflow Direction

- 1 Press **SWING** during operation.
 - Each time the button is pressed, the airflow direction louvers change their movement.

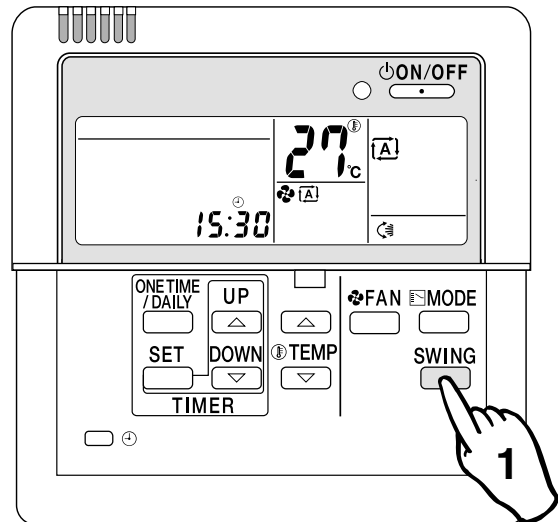

■ Wall Mounted Types (without horizontal swing function)

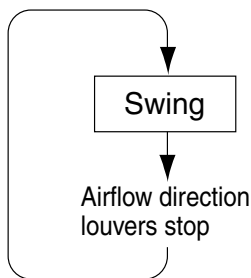

The horizontal airflow direction louvers move up and down.

The louvers stop just when the button is pressed.

Adjustment of horizontal airflow direction

- The automatic moving range of the horizontal airflow direction louvers varies depending on the operation mode.



Notes

- In fixing the horizontal airflow direction, keep the horizontal airflow direction louvers tilted downward in the heating mode, and keep them nearly horizontal level in the cooling or DRY mode. This will enhance the cooling and heating effect.
- On the air conditioners with vertical and horizontal swing function, be sure to adjust the airflow directions using the remote controller. Do not forcibly adjust louvers by hand or a malfunction may occur.

■ Wall Mounted Type (with horizontal swing function)

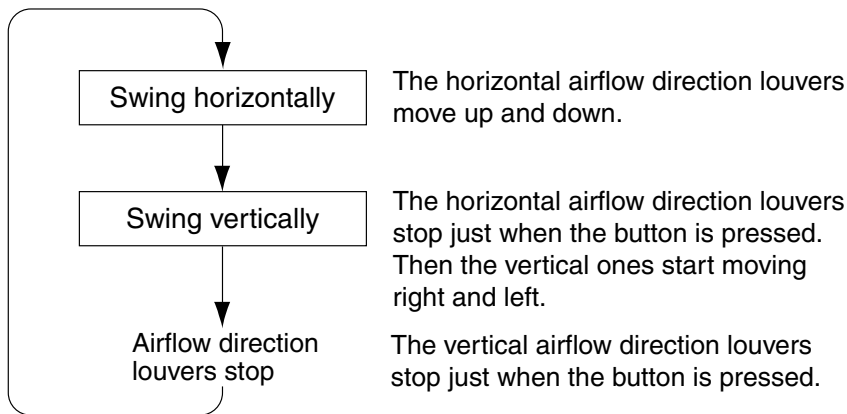

- The vertical and horizontal louvers cannot move at the same time.

■ Duct Connected Type (without swing function)

This function cannot be used.



Note

- The operating procedure and remote controller display are different depending on the indoor unit being connected. Read **How to Adjust the Airflow Direction** in the air conditioner's Operation Manual.

Timer Operation

The Timer Operation feature automatically turns off operation when you go to sleep and turns it back on when you wake up. Use the DAILY Timer mode on weekdays, and the ONE TIME timer mode on weekends.

■ To select the ONE TIME timer mode:

1 Press  to select the ONE TIME timer mode.

- Each time the button is pressed, the modes change as follows.

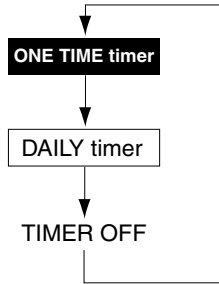

The timer lamp lights up.

■ To cancel the timer settings:

1 Press  to clear the timer settings.

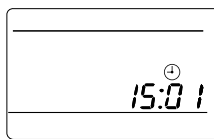

The **ONE TIME** or **DAILY TIMER** disappears from the display, and the timer lamp goes out too.

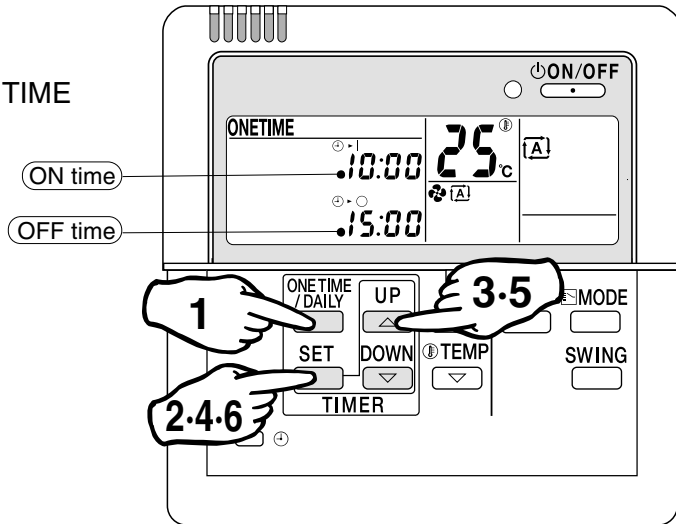

(Timer settings displayed)



Notes

- Even when the timer has been off, its programmed settings are still in memory.
- If the system has the timer control ON but you start and stop it manually using the ON/OFF button before the designated ON time, the system will restart again at the programmed ON time.

Precautions in setting the timer



- Before starting the timer operation, make sure the current time is correct. If not, set the clock correctly. (→ page 5)
- In making time settings, --:-- is displayed to make it easy to disable the timer too.
- If one minute has passed before making any timer setting, the previous timer settings are reintroduced and the timer is on standby. In this case, use the  (time setting) button and make your desired timer settings.

Timer operation

- When the ON timer is programmed, the system starts one hour (maximum) earlier so that the temperature set by the remote controller is reached just in time.
- When the ONE TIME timer is programmed, the current time is no longer displayed.

■ ONE TIME timer

Once the timer has been activated and then deactivated, it is in the OFF mode. The ON or OFF timers can be programmed.

1 Press  to select the ONE TIME timer. **4** Press .

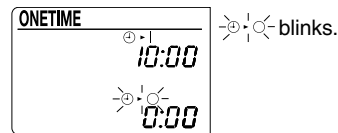
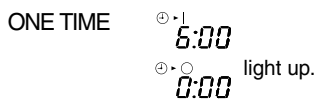

2 Press .

5 Press  to make the OFF timer setting.

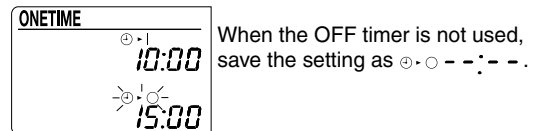
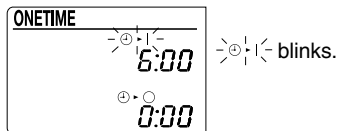

3 Press  to make the ON timer setting.

6 Press .
(The ONE TIME timer is now programmed.)

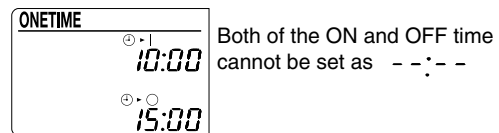
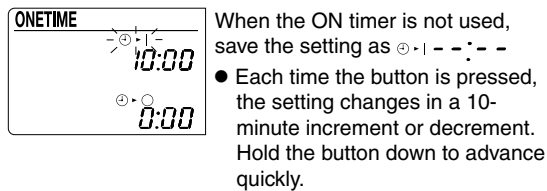

Example of display with the ONE TIME timer programmed

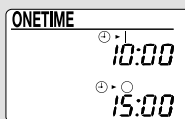

ONE TIME timer programmed.
(The set time is displayed.)



ON timer activated and system starts.
(The ON timer setting no longer displays.)

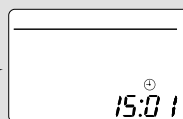

OFF timer activated, and system stops.
(The timer setting no longer displays.)



Notes

- In the following cases, reset the clock (the time setting is kept in the memory).
 - The circuit breaker has been activated.
 - The power fails.

Timer Operation

■ To select the DAILY timer mode:

1 Press  to select the DAILY timer mode.

- Each time the button is pressed, the modes change as follows.

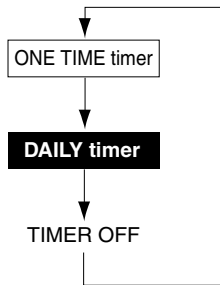

The timer lamp lights up.

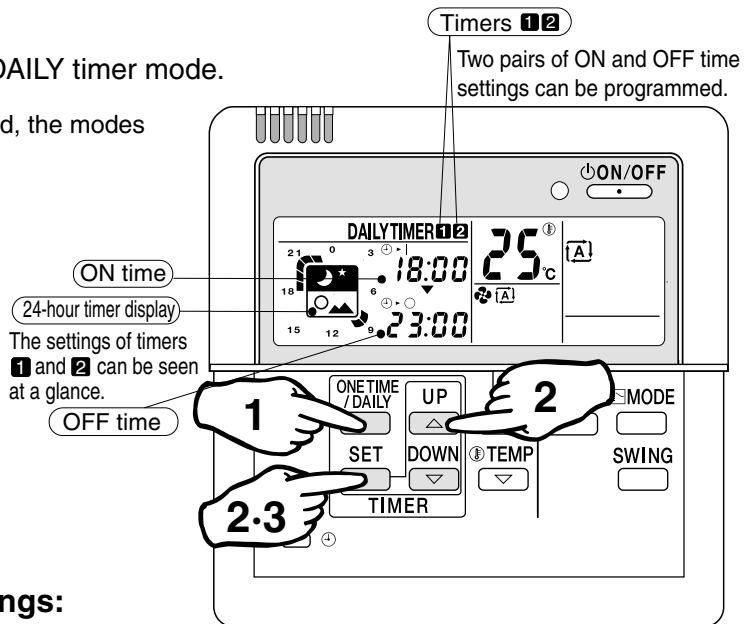

(Timer settings displayed)

■ To cancel the timer settings:

1 Press  to clear the timer settings.

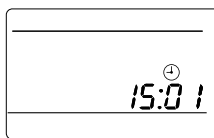

The **ONE TIME** or **DAILY TIMER**, and the timer lamp are no longer displayed.

Example of display with DAILY timer programmed

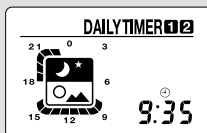

Timers 1 and 2 programmed.

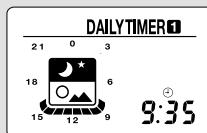

Timer 1 alone programmed.



Note

- The system starts and stops repeatedly until the DAILY timer is set off. Before you leave home for a long time, set the DAILY timer off.





■ DAILY timer

After programming, the system starts and stops each day at the preset times. Two pairs of time settings can be programmed.

(Example: 8:00 ~ 10:00, and 18:00 ~ 23:00)

1 Press  to select the DAILY timer.  lights up. DAILY timer indication appears.

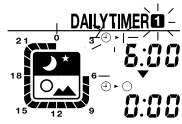
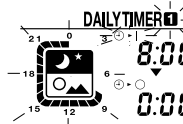
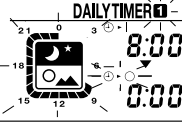
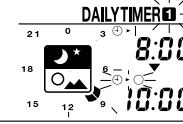
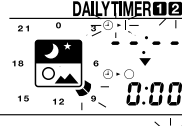
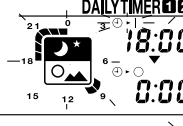
2 Make the ON and OFF time settings. ● Take the steps from ① to ⑧.
Program example: 8:00 ~ 10:00, and 18:00 ~ 23:00

Settings		Procedure	
		Press 	Press  to make the timer setting. 
Timer 1	ON time setting ● When the timer 1 is not used, save the setting as ①- -:-:-	① 	② 
	OFF time setting	③ 	④ 
Timer 2	ON time setting ● When the timer 2 is not used, save the setting as ⑤- -:-:-	⑤ 	⑥ 
	OFF time setting	⑦ 	⑧ 

3 Press . The DAILY timer is now programmed.



Note

- If the following appears on the display, the timer must be reprogrammed.

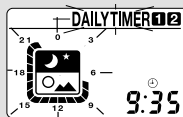

The 24-hour timer display is blinking.

This means that Timers **1** and **2** are programmed for the same time settings. New time settings must be made.



The 24-hour timer display is blinking.

This means that the timer has not been programmed yet.

Cleaning

Cleaning the remote controller

- Wipe it clean with soft, dry cloth.
Do not use any water hotter than 40°C (104°F), or volatile liquids such as benzine, gasoline and thinner, polishing powder, or anything hard such as a scrub brush.

When the unit is not used for a long time

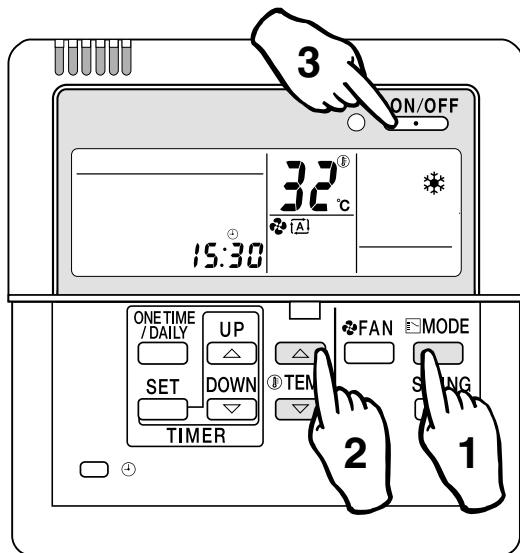

- ① On a sunny day, keep the system running for half a day in the FAN mode to dry it up inside.

FAN mode

- 1 Press to select the cooling mode.
 - 2 Press to adjust the set temperature to 32°C (90°F).
 - 3 Press .
 - The airflow rate remains the same, and is not adjustable.
 - Run the system when the room temperature is below 28°C (82°F).
- ② Finally turn off the circuit breaker dedicated for the room air conditioner.
 - ③ Clean the air filter and place it back into position.

13.6 <BRCW901A03/08> Wired Remote Controller Cord

Safety Precautions

- Turn OFF the controlled equipment when connecting the equipment.
- Hold the plug of the connector when connecting or disconnecting the connector.

Precautions for Use

- This remote controller cable is of thin-profile BRC944-series remote controller units.
- Be sure to ground both ends of the shield wire.
- Install the controlled equipment after reading through the installation manual of the equipment.

Complete Parts

• Remote Controller Cable

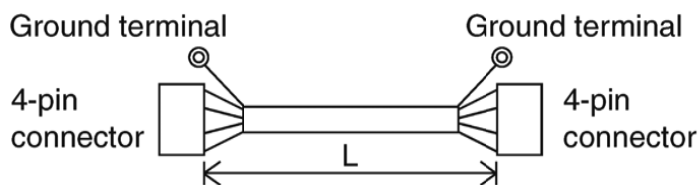

Parts number	L
BRCW901A03	Approx. 3m
BRCW901A08	Approx. 8m

• Installation Manual

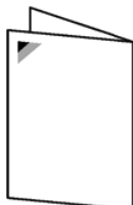

• Packing Case

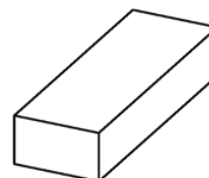

13.7 <KRP413BB1S> Wiring Adaptor

Safety Precautions

- Read these safety precautions carefully before installing the unit, and be sure to install the unit properly.
- This manual classifies precautions to the user into the following two categories. These warnings and cautions are for your safety. Follow them.

⚠ WARNING	Faulty installation can result in death or serious injury.
⚠ CAUTION	Faulty installation can result in serious injury, damage to property, or other serious consequences.

- After installation is complete, test the unit to confirm that it is working properly, and instruct the owner its proper use.

⚠ WARNING

- Installation should be left to the dealer from whom you purchased the unit, or another qualified professionals.
- Install the unit securely according to the installation manual. Faulty installation may lead to electric shock or fire.
- Be sure to use the supplied or specified parts. Using other parts may lead to electric shock or fire.
- Install the unit securely in a location that will support its weight. If installed in a poor location or improperly installed, the unit may not work as intended.
- For electrical work, follow local electric standards and the installation manual. Faulty installation may lead to fire or electric shock.
- Do not bundle the power cord, or attempt to extend it by splicing it with another cord or by using an extension cord. Do not place any other load on the power circuit used for the unit. Improper wiring may lead to electric shock, heat generation or fire.
- Use dedicated wiring for all electrical connections, and be sure to arrange the wiring so that force applied to the wiring will not damage the terminals. Poor wiring or installation may cause electric shock, heat generation or fire.

⚠ CAUTION

- Before installation, unplug the air conditioner to ensure safety. Failure to do so may cause electric shock.
- Static electricity may damage electric components. Before connecting cables and communication lines, and operating the switches, be sure to discharge any electrical charge from your body (by, for example, touching the earth line)
- Do not install the unit in a location where it may be exposed to flammable gases. If gas leaks and build up around the unit, it may catch fire.
- Do not place the wiring close to the power cord, inter-unit cable, or pipes which generate noise. Treat the wiring with care.

1. Functions and Features

- On/Off setting
- Switching between Instantaneous Contact/Normal Contact
- Connection with fan coil remote controller
- Automatic reset after power failure
- Output of normal operation signals/malfunction signals

2. Field Wiring

For interconnecting wiring, use Daikin KDC100A12 cable (not supplied) or other similar cable. Use a vinyl-covered wire or cable with four conductors each with a thickness of 0.2 to 1.25 mm².

■ Optional cable KDC100A12 (without connectors)

Specifications: 0.2 mm² × 4 core (sheathed)
 Outer diameter: φ5.3
 Length: 100 m
 Colour: Grey

Note : Keep any wiring for the control unit away from the power cord to prevent electrical noise.

Installation ①

1 Installation diagram

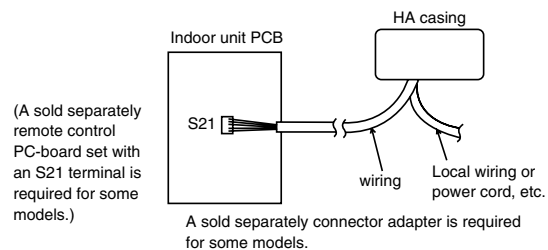

2 Components

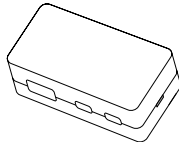
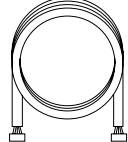
① HA casing ASSY (Remote Control PCB is attached in the HA casing.) 	② Wiring (approx. 0.8 m) (Cannot be made longer.) 
③ Accessories Binding band (6 pcs.) • Screws for attaching to the wall (3 pcs.)	
④ Installation manual	

Installation ②

Attaching HA Case ASSY

- Use the 3 supplied screws to attach the HA casing ASSY.

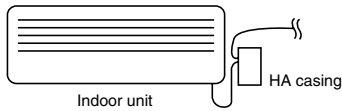

Install the HA casing ASSY as close to the indoor unit as possible.

① Removal of upper HA casing

- (1) Insert a flat-blade screwdriver into the groove between the upper and lower HA casings.

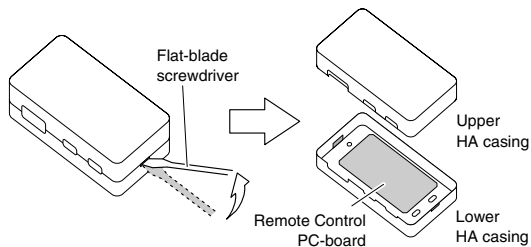

- (2) Lift the handle of the screwdriver upward.

- ② Mount and secure the lower HA casing directly on the wall with the provided screws inserted into the screw holes (a round hole and two ellipse holes) of the casing.

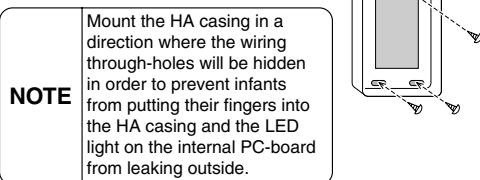

- ③ After connecting the cables (refer to the following sections), replace the case front. Be careful not to damage the wiring in the case.

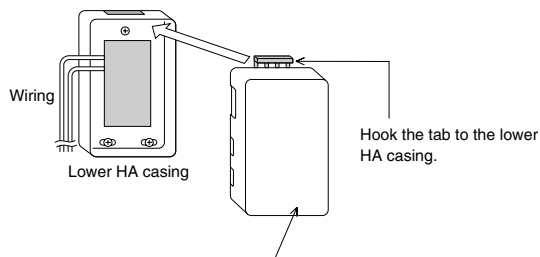

Press the lower part of the upper HA casing and press fit it onto the lower HA casing.
Press the upper HA casing precisely until a clicking sound is heard.

Wiring ①

1. Wiring

- ① Connect one end of the wiring to connector S21 of the PCB in the indoor unit.
- ② Connect the other end of the wiring to connector S6 of the Remote Control PCB.
- ③ Connect field wiring according to the functions assigned to each connection terminal of the Remote Control PCB.
- ④ Secure all wires.

1 Securing wires in the HA casing ASSY

① Connection of wiring

Connect the wiring to the connector terminals.

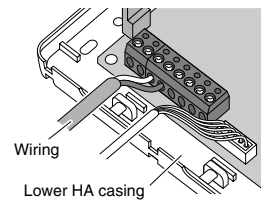

② Fixation of wiring

- (1) Insert the provided binding band under the pillar of the HA casing and secure the covers of the wiring with the binding band.

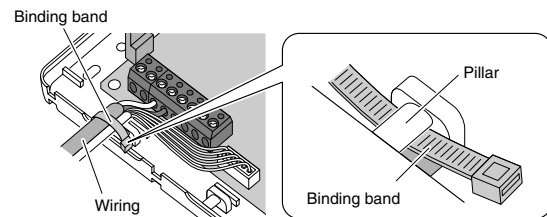

- (2) Insert the second binding band into the groove on the side of the HA casing and fix the wiring securely so that the wiring will not be disconnected.

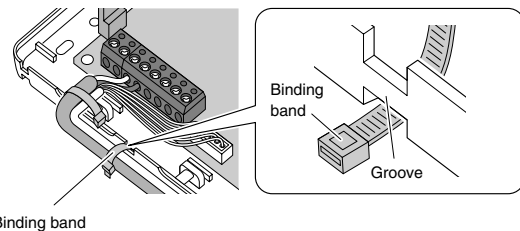

A large number of wires

Make a slit with an appropriate tool, such as a cutter knife, on the thin part of the upper HA casing along the frame. Then cut the part with an appropriate tool, such as a pair of nippers.

(NOTE) Cut off only the thin part required for wiring.

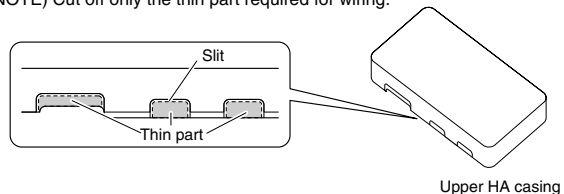

2 Securing wires in the indoor unit

- The method for securing wire varies depending on the model of the air conditioner. See your air conditioner installation manual for details.

Wiring ②

2. Automatic Reset After Power Failure

- This PCB stores the following data in the event of a power failure (the storage period is limitless).
 - ① On/Off (see Note 1)
 - ② Operation modes (see Note 2)
 - ③ Temperature setting
 - ④ Air flow rate
 - ⑤ On/Off status of remote controller
- (Note 1 When SW1-2 is in Off mode, the unit will not be activated.)
 (Note 2 The following settings apply to the models below.)

	Mode before the power outage	COOLING	HEATING
Room air conditioner			
Models with Humid heating and Reheating dehumidifying functions.		DRY COOLING	HUMID HEATING
Models with Reheating dehumidifying function.			HEATING

(Note 3 Not all settings will be saved (e.g., humidity or swing settings will not be saved).)

3. Monitor Signal Output (normal operation and malfunction)

- Maximum length of the wiring is 100 m. No external power supply is required.

1 Monitor signal output for LED

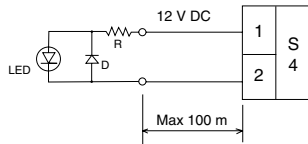

Locally procured parts

Item	Manufacturer	Type
LED	Rohm	SLR-342
D	Rohm	1SS133
R		510 ohm 1/4W

2 Monitor signal output (normal operation and malfunction) using external relay contacts

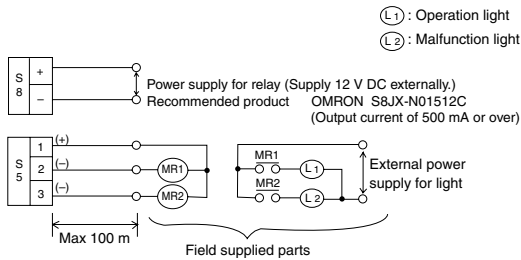

Field procured parts (Recommended external relay contacts)

Manufacturer	Type	Coil rated voltage	Coil resistance
Omron	MY relay	12 V DC	160 ohm ± 10%

4. Connection with Remote Controller

Example connections with three kinds of remote controllers are shown below. Note: These connections cannot be used in combination.

1 Remote control with switch (field supply)

- Set SW1-1 to Off and select Operation Mode 1.



<Instantaneous Contact>

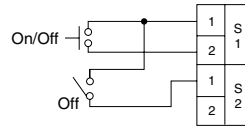

- The remote controller most recently used (local or air conditioner) takes precedence.
- Use a remote controller with a pulse width of 100 msec or more.

<Normal Contact>

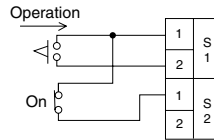

- Power On/Off cannot be controlled from the unit's remote controller. (Three beeps for signal reception will be heard continuously when the wireless remote controller is operated.)
- When power is restored after a power failure in this mode, On or Off is determined according to the current settings of the remote controller.

2 Fan coil remote controller

- Set SW1-1 to On and select Operation Mode 2.
- Most settings (power On/Off, air flow rate, mode change) cannot be made using the air conditioner's remote controller.
- When power is restored after a power failure in this mode, On or Off is determined according to the current settings of the remote controller.
- When the Cooling/Heating mode is changed, use the air conditioner's remote controller to adjust the temperature.

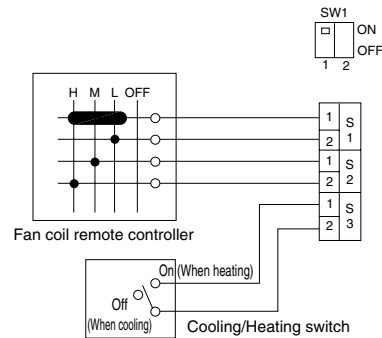

Test Operation and Confirmation

1. When the System is Not Working

- Is the air conditioner working properly?
- Are the connectors of the wiring properly connected?
- Are the remote controller and field wiring properly connected?
- Are all switch settings correct?
- If there is nothing apparently wrong, conduct a diagnostic check using the following procedure.

■ Diagnostic check

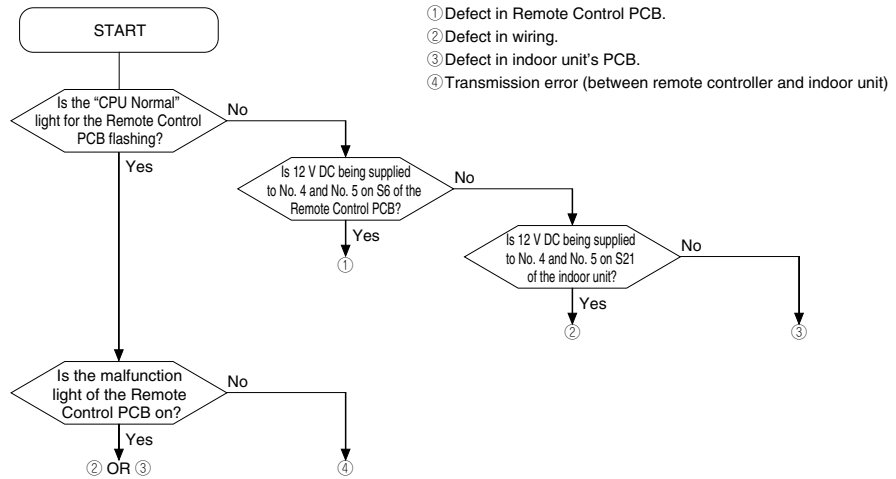

2. Switch Settings and Connection Terminals

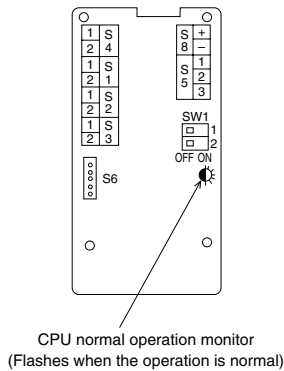

SW1-1	Selecting the operation mode	OFF	Operation mode 1 (Used with the exception of fan coil remote controller settings)			
		ON	Operation mode 2 (Used with fan coil remote controller settings)			
SW1-2	Selecting On/Off when power is restored after a power failure	OFF	Always Off			
		ON	Off if operation was in Off mode before power failure; On if operation was in On mode before power failure			
S1 S2 S3	SW1-1: OFF (Operation mode 1)	S1 (1) - S2 (1)		Instantaneous contact OPEN	Normal contact CLOSE	
		S1 (1) - S1 (2)		Pulse input On/Off switching	OPEN, Not activated	
		S2 (2), S3			Not used	
		S1, S2 OPEN		Not activated		
		S1 (1) - S1 (2) CLOSE		On, airflow: L tap		
	SW1-1: ON (Operation mode 2)	S1 (1) - S2 (1) CLOSE		On, airflow: M tap		
		S1 (1) - S2 (2) CLOSE		On, airflow: H tap		
		S3 (With the remote controller only)	OPEN	Cooling		
			CLOSE	Heating		
		S4	(1) - (2)	Voltage on (12 V DC), normal operation light output		
S5	(1) - (2)	Normal operation light output (power for light required)				
	(1) - (3)	Malfunction light output (power for light required)				
S6 connector		Connect with connector S21 on the PCB of the indoor unit				
S8	(+) - (-)	Relay 12 V DC power supply terminal (Field supplied parts)				

13.8 <DCS302C71> Central Remote Controller (Installation)

Please read these "SAFETY CONSIDERATIONS" carefully before installing air conditioning equipment and be sure to install it correctly. After completing the installation, make sure that the unit operates properly during the start-up operation. Please instruct the customer on how to operate the unit and keep it maintained. Also, inform customers that they should store this installation manual along with the operation manual for future reference. This air conditioner comes under the term "appliances not accessible to the general public".

Meaning of warning, caution and note symbols.

- ⚠ WARNING** Indication a potentially hazardous situation which, if not avoided, could result in death or serious injury.
- ⚠ CAUTION** Indication a potentially hazardous situation which, if not avoided, may result in minor or moderate injury. It may also be used to alert against unsafe practices.
- ⚠ NOTE** Indication situation that may result in equipment or property-damage-only accidents.

⚠ WARNING

Ask your dealer or qualified personnel to carry out installation work. Do not try to install the machine by yourself.
Improper installation may result in water leakage, electric shocks or fire.

Perform installation work in accordance with this installation manual.
Improper installation may result in water leakage, electric shocks or fire.

Be sure to use only the specified accessories and parts for installation work.
Failure to use the specified parts may result in water leakage, electric shocks, fire or the unit falling.

Carry out the specified installation work after taking into account strong winds, typhoons or earthquakes.
Improper installation work may result in the equipment falling and causing accidents.

Make sure that a separate power supply circuit is provided for this unit and that all electrical work is carried out by qualified personnel according to local laws and regulations and this installation manual.
An insufficient power supply capacity or improper electrical construction may lead to electric shocks or fire.

Make sure that all wiring is secured, the specified wires are used, and no external forces act on the terminal connections or wires.
Improper connections or installation may result in fire.

When wiring the power supply and connecting the remote controller wiring and transmission wiring, position the wires so that the electric parts box lid can be securely fastened.
Improper positioning of the electric parts box lid may result in electric shocks, fire or the terminals overheating.

Before touching electrical parts, turn off the unit.

Ground the air conditioner. Do not connect the ground wire to gas or water pipes, lightning rod or a telephone ground wire.
Incomplete grounding may result in electric shocks.

When installing or relocating the system, be sure to keep the refrigerant circuit free from substances other than the specified refrigerant (R4-10A), such as air.

Do not reconstruct or change the settings of the protection devices.
If the pressure switch, thermal switch, or other protection device is shorted and operated forcibly, or parts other than those specified by Daikin are used, fire or explosion may result.

Do not touch the switch with wet fingers.
Touching a switch with wet fingers can cause electric shock.

Install an leak circuit breaker, as required.
If an leak circuit breaker is not installed, electric shock may result.

Do not install the air conditioner or the remote controller in the following locations:

- (a) where a mineral oil mist or an oil spray or vapor is produced, for example in a kitchen
Plastic parts may deteriorate and fall off or result in water leakage.
- (b) where corrosive gas, such as sulfurous acid gas, is produced
Corroding copper pipes or soldered parts may result in refrigerant leakage.
- (c) near machinery emitting electromagnetic waves
Electromagnetic waves may disturb the operation of the control system and result in a malfunction of the equipment.
- (d) where flammable gases may leak, where there are carbon fiber or ignitable dust suspensions in the air, or where volatile flammables such as thinner or gasoline are handled.
Operating the unit in such conditions may result in fire.

⚠ CAUTION

Be very careful about product transportation.

Safely dispose of the packing materials.
Packing materials, such as nails and other metal or wooden parts, may cause stabs or other injuries. Tear apart and throw away plastic packaging bags so that children will not play with them. If children play with a plastic bag which was not torn apart, they face the risk of suffocation.

Do not turn off the power immediately after stopping operation.
Always wait at least five minutes before turning off the power. Otherwise, water leakage and trouble may occur.

⚠ NOTE

Install the indoor and outdoor units, power supply wiring and connecting wires at least 3.5ft. away from televisions or radios in order to prevent image interference or noise.
(Depending on the radio waves, a distance of 3.5ft. may not be sufficient enough to eliminate the noise.)

Remote controller (wireless kit) transmitting distance can result shorter than expected in rooms with electronic fluorescent lamps.(inverter or rapid start types)
Install the indoor unit as far away from fluorescent lamps as possible.

This unit is a class A product.
In a domestic environment this product may cause radio interference in which case the user may be required to take adequate measures.

Dismantling of the unit, treatment of the refrigerant, oil and eventual other parts, should be done in accordance with the relevant local and national regulations.

1 COMPONENTS

Check the following components are included in this optional accessory before installation.

Installation screw (M4 x 16)	4
Operation manual	1
Installation manual	1
Installation table	1

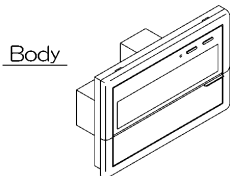

Body

When using this optional accessory an electric parts box of KJB311A is required. For installation, a steel electric parts box to be embedded is mandatory.

2 SYSTEM CONFIGURATION

With the central remote controller, unified operation/stop is possible with up to a maximum 64 groups of indoor units. When using 2 central remote controllers, unified operation is possible with up to a maximum 128 groups. With this optional accessory, setting of control modes including operation, stop, operation controlled by timer, and ON/OFF control possible/impossible by remote controller can be set individually by zones while it enables to control and display the operation state such as set temperature. It can be connected with the external key system, host computer monitor panel, etc., through forced OFF input (no-voltage normally open contactor). A zone is a one or more groups together. In general, the same settings are used throughout a zone.

- When using 1 central remote controller

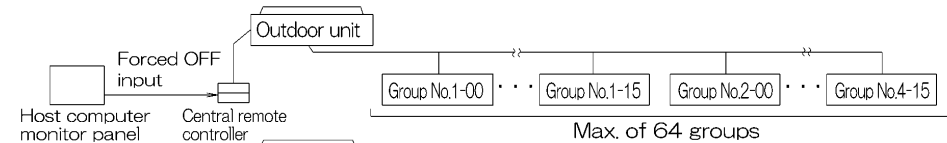

- When using 2 central remote controller

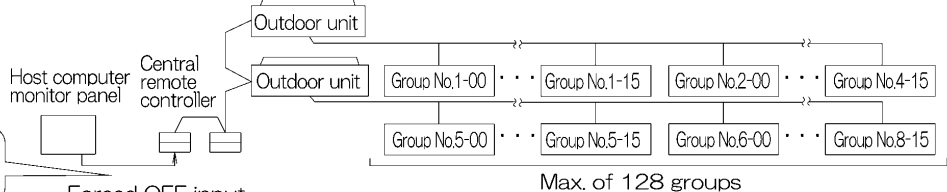

Forced ON/OFF command should be connected to one of the two units.

The central remote controller and the separately sold remote control adapter circuit board or group remote control adapter cannot be used together. See the D-BACS design guide for details.

3 INSTALLATION

- (1) Open the upper part of remote controller. Insert a ⊖ screwdriver (2 locations) into the recess between the upper part and the lower part of remote controller and twist the screwdriver lightly.

PC board is attached with both the upper and lower part of remote controller. Do not damage the board with the screwdriver.

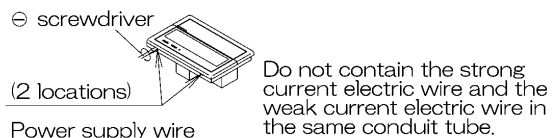

- (2) Open the upper part of remote controller and install the Electric parts box with the attached installation screws (M4 x 16).

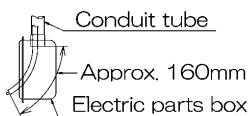

Installation screws (4)

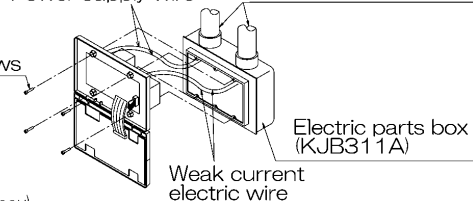

NOTE) Suitable length of the electric wire is about 160mm, (from electric parts box) If it is difficult to contain a long wiring, strip the sheathed part of the wiring.

4 INITIAL SETTING

Setting (1) through (3) are initialized when power is turned ON, therefore complete settings BEFORE activating the power. (The positions of connectors and switches used for settings in this section are shown in Fig. 1.)

- (1) Connector for setting master controller (X1A) (Provided with connector at factory set)
 - When using only 1 central remote controller, do not disconnect the connector for setting master controller. (Use the unit with the connector in the state in which it was delivered.)
 - When using multiple central remote controllers, or using the central remote controller in conjunction with the optional controllers for centralized control, makes settings as indicated in the below table.

Pattern of connection of optional controllers for centralized control			Connector for setting master controller (X1A) Setting, Removed		
Central remote controller	Unified ON/OFF controller	Schedule timer	Central remote controller	Unified ON/OFF controller	Schedule timer
1 to 4	1 to 16	1	Set one to "Used" and all the rest to "Not used"	Set all to "Not used"	"Not used"
		1			"Not used"

(Remove all the connectors for the central remote controller, the on/off controller, and the schedule timer when using the unit together with the Ve-UP controller, the master station II, the DMS interface, the payment management unit, or the parallel interface station.)

- (2) Address setting
Two central remote controllers can be used as shown in **2 SYSTEM CONFIGURATION**, to control anywhere up to a max. 128 groups of indoor units. In this case, group address must be set. This is done with the switch for setting each address (SS3).

SS3 setting	Indoor unit address	SS3 setting	Indoor unit address
SETTING EACH ADDRESS 5-00 ~ 8-15	To control indoor units from group Nos. 1-00 through 4-15	SETTING EACH ADDRESS 5-00 ~ 8-15	To control indoor units from group Nos. 5-00 through 8-15

- (3) MAIN/SUB changeover switch setting
With two central remote controllers, centralized control (indoor units) is possible from different locations. In this kind of set-up, it is necessary to set the MAIN/SUB changeover switch.

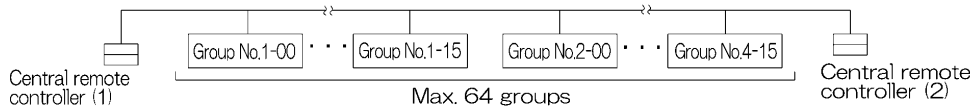

One of the two central remote controllers (1) . (2) is set to "MAIN" while the other is set to "SUB".

- (4) Setting of the sequential operation function
The central remote controller is equipped with a sequential operation function that sequentially turns indoor units on in 2-second intervals during unified operation. (Sequential operation is factory set to "ON.") To switch sequential operation ON or OFF, set as follows.

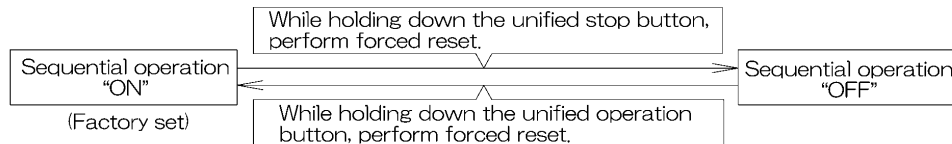

NOTE: The sequential operation function is designed to reduce the load on the power supply equipment, but does not guarantee that compressors will not be started simultaneously. You cannot therefore count on a capacity reduction effect by power supply equipment breaker selection.

- (5) Forced reset switch
When changing the setting of the connector for setting master controller, etc., you can reset simply by setting it to the reset side once and returning to the normal side, without turning the power OFF. (For normal operation, set the switch to the normal side.)

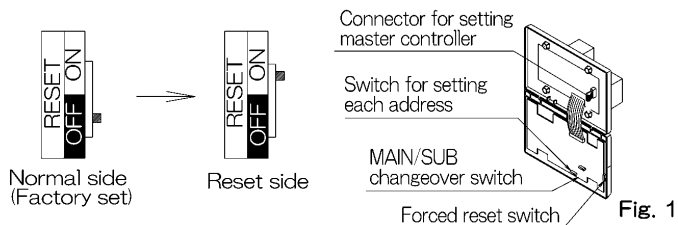
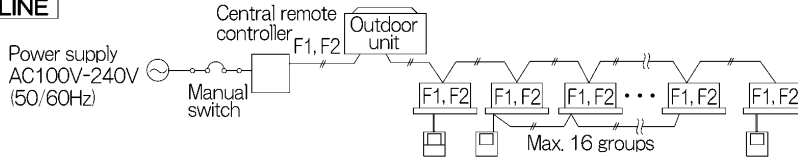

Fig. 1

5 ELECTRIC WIRING

WIRING OUTLINE



WIRING TO THE INDOOR UNIT AND OUTDOOR UNIT

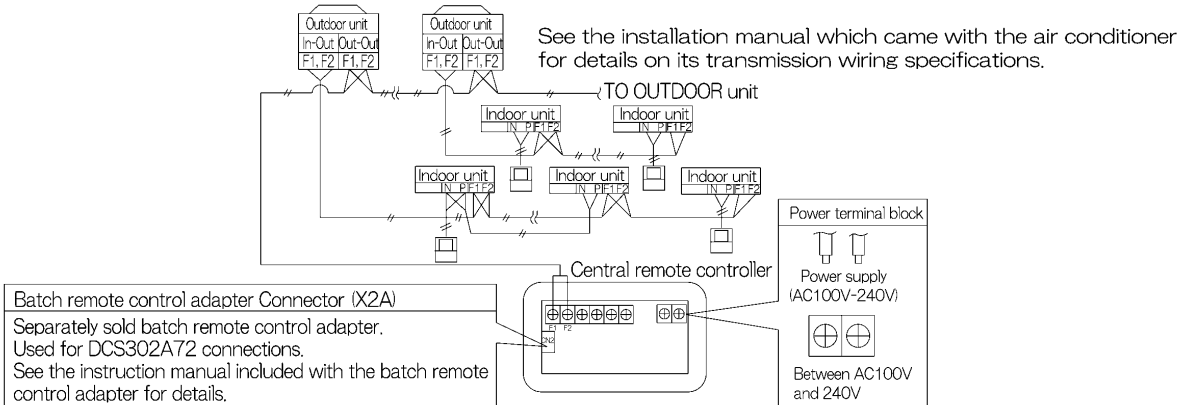

Wiring specifications

Power supply wiring	2mm ²
Transmission wiring for control	0.75 – 1.25 mm ² sheathed vinyl cord or cable (balanced type) – maximum length 1000 m (total overall wiring length 2000 m)
Manual switch	10A or 15A

Wire the indoor units to the outdoor units and between all power, indoor units, and remote controllers. See the instruction manual included with the indoor and outdoor units for details.

CONTROL TERMINAL STRIP

*1 For connecting Indoor unit (F1, F2)

*2 Forced OFF input (T1, T2)

None of the indoor units connected to the forced OFF input contact (non-voltage contact with minimal current) will operate when it is shut off.
 Use only contactors which guarantee the minimum applicable load DC 16V, 10mA.



NOTE) Use instantaneous contactor of over 200m sec. energizing time, when necessary.

*3 For schedule timer (D1, D2)

Power can be supplied to the schedule timer (DST301B61) separately sold. For details, refer to the installation manual of the schedule timer.

Wire *2 and *3 only when necessary.

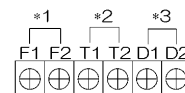





(NOTE)

Do not connect the power supply wiring (100 to 240V) to the control terminal strip. If connected by mistake, it may damage or burn electrical parts of optional controllers for centralized control and indoor unit. It may result in serious danger. Be sure to check wirings before turning the power ON.

6 SETTING GROUP NO. FOR CENTRALIZED CONTROL

Set the group number of each group of the indoor unit from the remote controller. (In case of no remote controller, also connect the remote controller and set the group No. Then, remove the remote controller.)

- (1) Turn ON the power of the indoor unit and central remote controller.
(Unless the power is ON, no setting can be made.)
Check that the installation and electrical wiring are correct before turning the power supply ON.
(When the power supply is turned ON, all LCD appear once and the unit may not accept the operation for about one minute with the display of “gg”.)
- (2) While in the normal mode, hold down the “” button for a minimum of 4 seconds.
The remote controller will enter the FIELD SET MODE.
- (3) Select the MODE No. “gg” with the “” button.
- (4) Use the “” button to select the group No. for each group.
(Group numbers increase in the order of 1-00,1-01,...1-15, 2-00,...8-15.)
- (5) Press “” to set the selected group No.
- (6) Press “” to return to the NORMAL MODE.

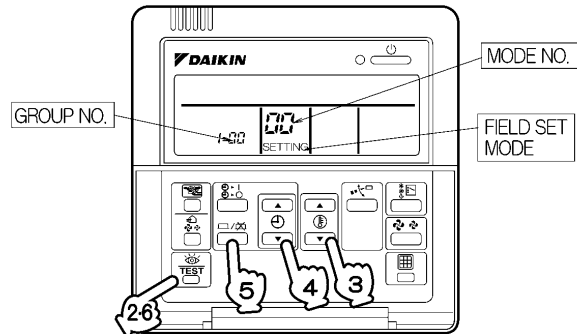









- NOTES)
- For simplified remote controller, see the installation table.
 - See the instruction manuals which came with the VentiAir and adapters (i.e., multi-purpose adapters) for details on their Group No. settings.

NOTICE Enter the group No. and installation place of the indoor unit into the installation table in the operation manual. Be sure to keep the operation manual for maintenance.

7 TEST OPERATION (Perform a test operation in the individual screen before registering zones.)

Before starting test operation, check that the power is supplied to the indoor and outdoor units, and central remote controller.

- (1) Select the display “INDIVIDUALLY”
Press “” button to display “INDIVIDUALLY”
- (2) Select the group to be tested.
Select the group No. with “” “” “” “” button.
- (3) Press “” button to select the test operation mode.
“TEST” is displayed.
“HOST” is displayed on the remote controller.
- (4) Press “” button within 10 seconds after entering into the test operation mode.
Operation the unit for 30 minutes.
When pressing the “” button, the unit stops operating.
If the operation lamp flashes, it indicates a malfunction.
Call the group of flashing display, confirm malfunction code, and check the source of malfunction.
(The operation manual lists all error codes, so refer to it.)

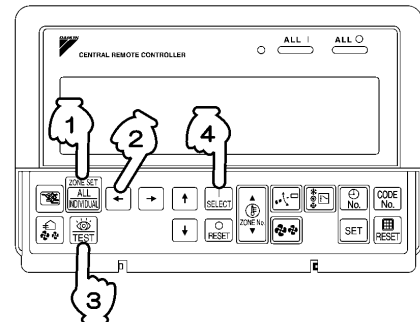

- NOTES)
- For test operation, refer to the installation manual of the outdoor unit.
 - After turning the power supply ON, if the unit does not accept operation for two minutes or more with the display of “gg”, check the following points.
 - Check that setting of the connector for setting master controller is correct.
 - Check that the group No. for centralized control has been set.

13.9 <DCS302C71> Central Remote Controller (Operation)

BEFORE USE

■ GENERAL DESCRIPTION OF SYSTEM

This central remote controller can monitor and control up to 64 indoor unit groups.
Using two central remote controllers allows monitoring and controlling of up to 128 indoor unit groups.

Main Functions

1. Batch starting and stopping of indoor units connected to the central remote controller.
2. Handling of operation settings such as start/stop, timer operation, remote controller prohibition/permission, etc., and operation status settings such as temperature.
3. Operation status monitoring of operation mode, set temperature, etc.
4. Can be connected to an external central monitor panel and key system using the forced stop input (non-voltage a connector).

- When using 1 central remote controller

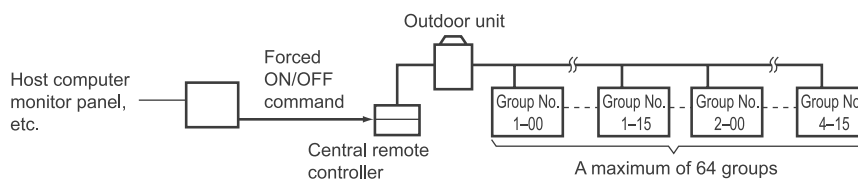

- When using 2 central remote controllers

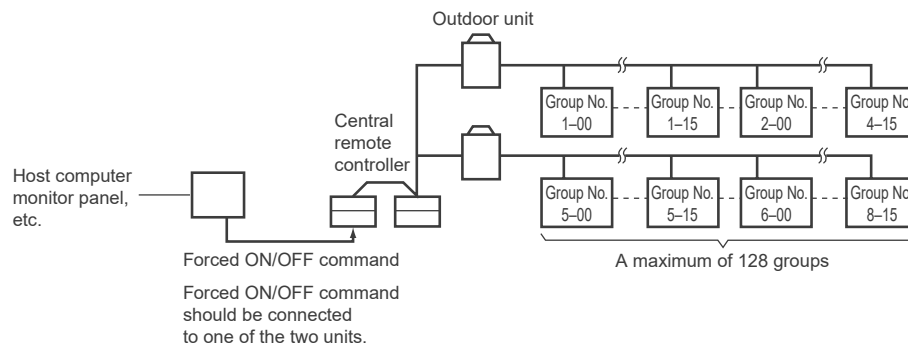

(The central remote controller and the separately sold remote control adapter circuit board or group remote control adapter cannot be used together.)

* GROUP OF INDOOR UNIT refers to the below.

1. A single indoor unit without remote controller

1. A single indoor unit without remote controller

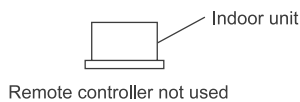

2. A single indoor unit controlled by one or two remote controllers

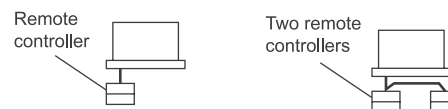

3. Maximum of 16 indoor units, group-controlled by one or two remote controllers

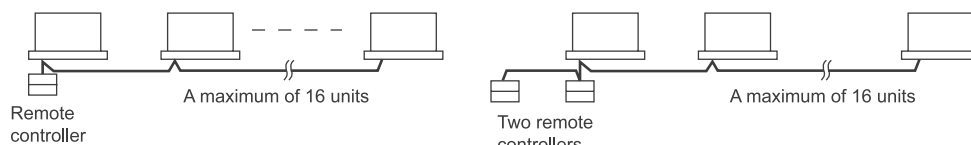

*** Zone control from the central remote controller**

Zone control is available from the central remote controller. With it, it is possible to make unified settings for multiple groups, so setting operations are greatly simplified.

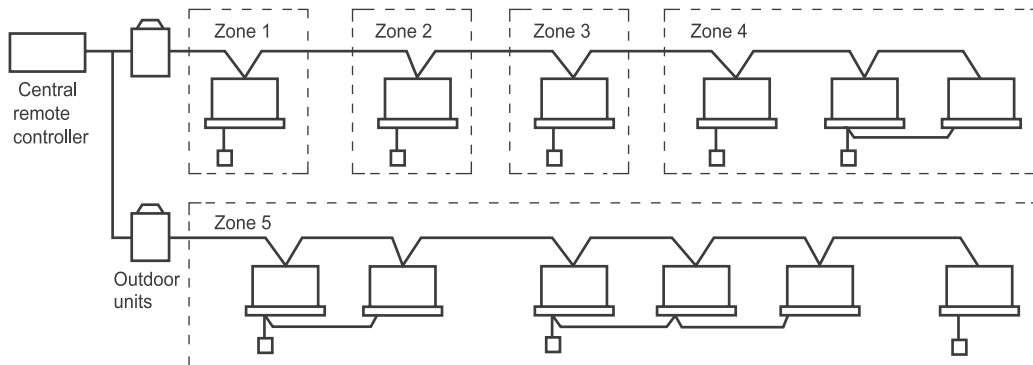

- Any setting you make within a given zone will apply to all groups in the said zone.
- A maximum of 64 zones can be set from a single central remote controller. (Each zone contains a maximum of 64 groups.)
- Zones can be set randomly from the central remote controller.

SAFETY CONSIDERATIONS

Please read these “SAFETY CONSIDERATIONS” carefully before installing air conditioning equipment and be sure to install it correctly. After completing the installation, make sure that the unit operates properly during the start-up operation. Please instruct the customer on how to operate the unit and keep it maintained. Also, inform customers that they should store this installation manual along with the operation manual for future reference. This air conditioner comes under the term “appliances not accessible to the general public”.

Meaning of danger, warning, caution and note symbols.

- ! DANGER** Indicates an imminently hazardous situation which, if not avoided, will result in death or serious injury.
- ! WARNING** Indicates a potentially hazardous situation which, if not avoided, could result in death or serious injury.
- ! CAUTION** Indicates a potentially hazardous situation which, if not avoided, may result in minor or moderate injury. It may also be used to alert against unsafe practices.
- ! NOTE**..... Indicates situation that may result in equipment or property-damage-only accidents.

Keep these warning sheets handy so that you can refer to them if needed.
Also, if this equipment is transferred to a new user, make sure to hand over this operation manual to the new user.

! DANGER

- **Any abnormalities in the operation of the air conditioner such as smoke or fire could result in severe injury or death.** Turn off the power and contact your dealer immediately for instructions.
- **Do not install the unit in an area where flammable materials are present due to risk of explosion resulting in serious injury or death.**
- **Safely dispose of the packing materials.** Packing materials, such as nails and other metal or wooden parts, may cause stabs or other injuries. Tear apart and throw away plastic packaging bags so that children will not play with them. Children playing with plastic bags face the danger of death due to suffocation.

! WARNING

- **Ask your dealer for installation of the air conditioner.** Incomplete installation performed by yourself may result in a water leakage, electric shock, and fire.
- **Ask your dealer for improvement, repair, and maintenance.** Incomplete improvement, repair, and maintenance may result in a water leakage, electric shock, and fire.
- **Improper installation or attachment of equipment or accessories could result in electric shock, short-circuit, leaks, fire or other damage to the equipment. Be sure only to use accessories made by Daikin which are specifically designed for use with the equipment and have them installed by a professional.**
- **Ask your dealer to move and reinstall the air conditioner or the remote controller.** Incomplete installation may result in a water leakage, electric shock, and fire.
- **Never let the indoor unit or the remote controller get wet.** It may cause an electric shock or a fire.

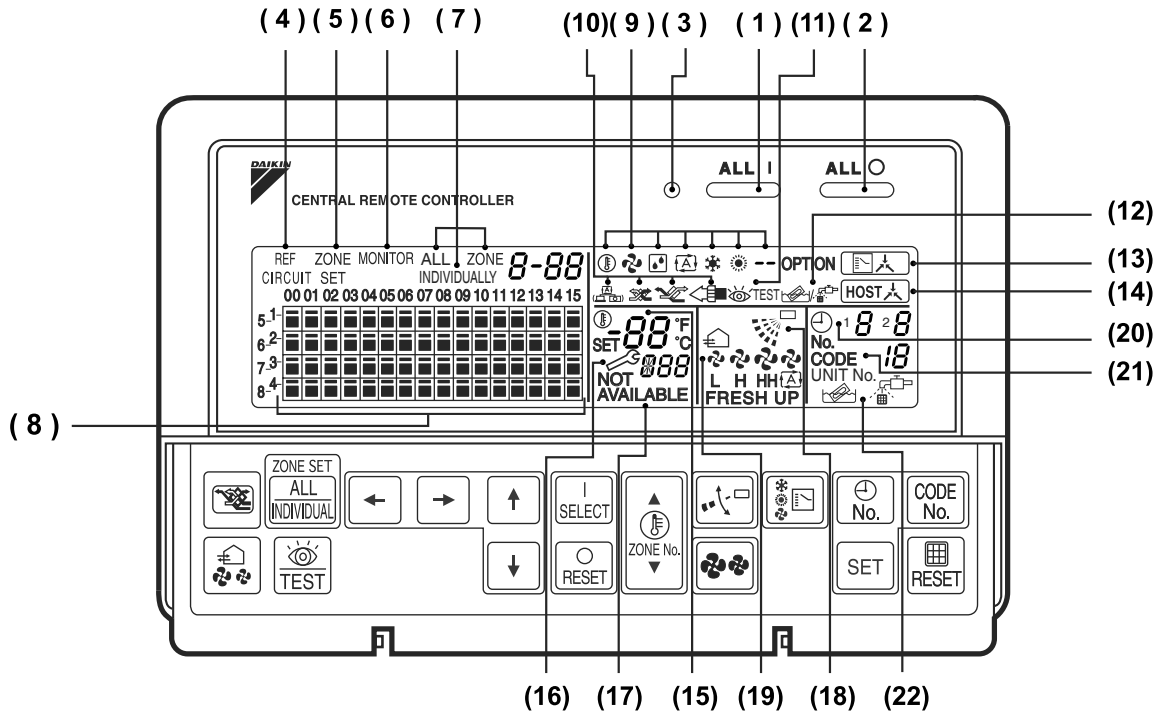

Fig. 1

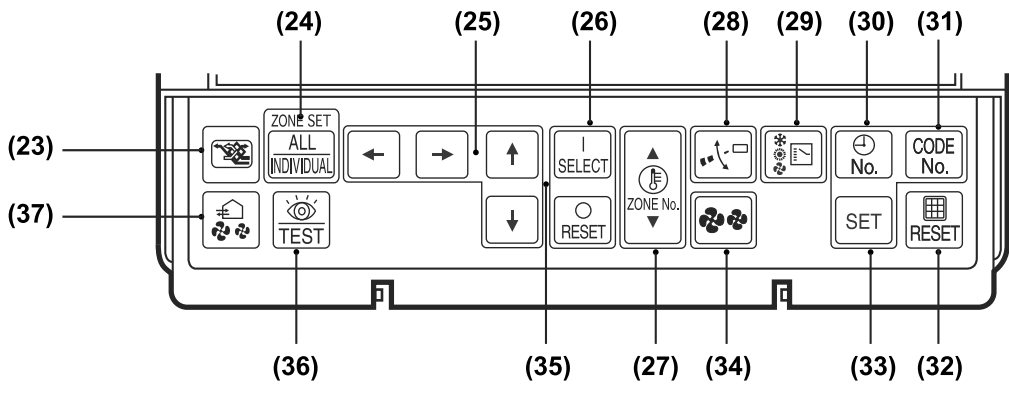

Fig. 2

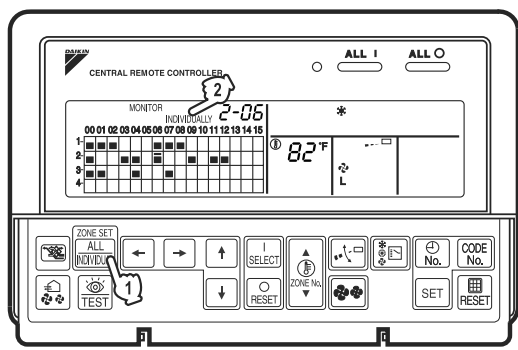

Fig. 3

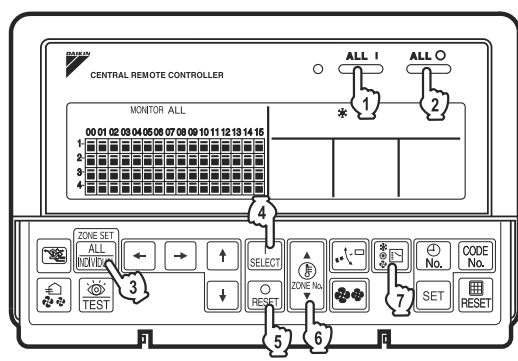

Fig. 4

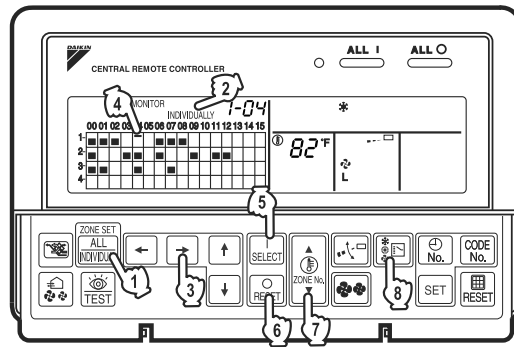

Fig. 5

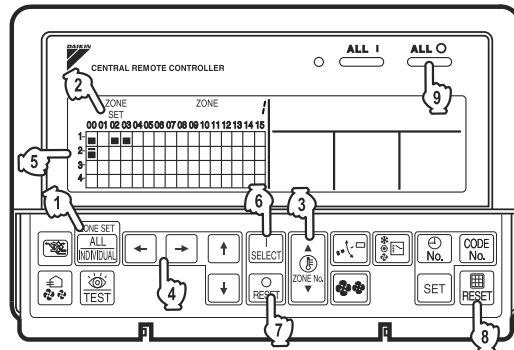

Fig. 6

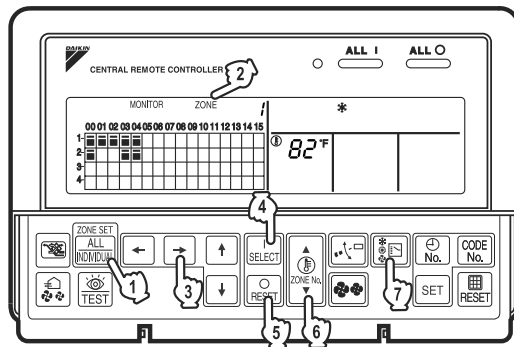

Fig. 7

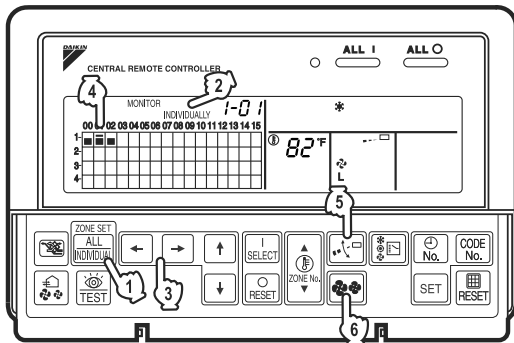

Fig. 8

- **Never use flammable spray such as hair spray, lacquer or paint near the unit.**
It may cause a fire.
- **Do not allow children to play on or around the unit as they could be injured.**
- **Never replace a fuse with that of wrong ampere ratings or other wires when a fuse blows out.**
Use of wire or copper wire may cause the unit to break down or cause a fire.
- **Never inspect or service the unit by yourself.**
Ask a qualified service person to perform this work.
- **Cut off all electric waves before maintenance.**
- **Do not wash the air conditioner or the remote controller with excessive water.**
Electric shock or fire may result.
- **Do not touch the switch with wet fingers.**
Touching a switch with wet fingers can cause electric shock.
- **Never touch the internal parts of the controller.**
Do not remove the front panel because some parts inside are dangerous to touch. In addition, some parts may be damaged by touching. For checking and adjusting internal parts, contact your dealer.
- **Check the unit stand for damage on a continuous basis, especially if it had been in use for a long time.**
If left in a damaged condition the unit may fall and cause injury.
- **Placing a flower vase or other containers with water or other liquids on the unit could result in a shock hazard or fire if a spill occurs.**

CAUTION

- **Avoid placing the controller in a spot splashed with water.**
Water coming inside the machine may cause an electric leak or may damage the internal electronic parts.

- **Do not operate the air conditioner when using a room fumigation - type insecticide.**
Failure to observe could cause the chemicals to become deposited in the unit, which could endanger the health of those who are hypersensitive to chemicals.
- **Do not turn off the power immediately after stopping operation.**
Always wait at least five minutes before turning off the power. Otherwise, water leakage and trouble may occur.
- **The appliance is not intended for use by young children or infirm persons without supervision.**
- **The remote controller should be installed in such a way that children cannot play with it.**

NOTE

- **Never press the button of the remote controller with a hard, pointed object.**
The remote controller may be damaged.
- **Never pull or twist the electric wire of the remote controller.**
It may cause the unit to malfunction.
- **Do not place the controller exposed to direct sunlight.**
The LCD display may get discolored, failing to display the data.
- **Do not wipe the controller operation panel with benzene, thinner, chemical dustcloth, etc.**
The panel may get discolored or the coating peeled off. If it is heavily dirty, soak a cloth in water-diluted neutral detergent, squeeze it well and wipe the panel clean. And wipe it with another dry cloth.
- **Dismantling of the unit, treatment of the refrigerant, oil and eventual other parts, should be done in accordance with the relevant local and national regulations.**

CONTENTS

<p>BEFORE USE 1</p> <p style="padding-left: 20px;">GENERAL DESCRIPTION OF SYSTEM 1</p> <p>SAFETY CONSIDERATIONS 2</p> <p>FEATURES AND FUNCTIONS 6</p> <p>NAMES AND FUNCTIONS OF THE OPERATING SECTION 7</p> <p>OPERATION..... 8</p> <p style="padding-left: 20px;">Individual screen, all screen, zone screen 8</p> <p style="padding-left: 20px;">Batch operation and stop method 9</p> <p style="padding-left: 20px;">Group operation and stop method..... 9</p> <p style="padding-left: 20px;">Registering zones..... 9</p> <p style="padding-left: 20px;">Zone operation and stop method 10</p> <p style="padding-left: 20px;">Changing the fan direction and fan strength 11</p> <p style="padding-left: 20px;">Changing the ventilation mode and ventilation strength 11</p> <p style="padding-left: 20px;">Timer Number Setting 11</p> <p style="padding-left: 20px;">Setting the Operation Code..... 12</p>	<p>OPERATION MODE 13</p> <p style="padding-left: 20px;">Setting operation mode16</p> <p style="padding-left: 20px;">Group monitoring16</p> <p style="padding-left: 20px;">Error diagnosing function17</p> <p style="padding-left: 20px;">Setting master remote controller20</p> <p style="padding-left: 20px;">Display of time to clean21</p> <p>INSTALLATION TABLE 22</p> <p>OPTIONAL ACCESSORIES..... 23</p> <p>DOUBLE CENTRAL REMOTE CONTROLLERS 23</p> <p>SPECIFICATIONS..... 24</p> <p style="padding-left: 20px;">Specifications24</p> <p style="padding-left: 20px;">Outline drawings24</p> <p>Fig. 1, 2, 3, 4.....3</p> <p>Fig. 5, 6, 7, 8.....4</p> <p>Fig. 9, 10, 11, 12.....25</p> <p>Fig. 13, 14, 15, 16.....26</p>
--	--

FEATURES AND FUNCTIONS

■ Operation menu

This central remote controller can operate and stop machines by either group or zone.
 Batch operation and batch stop functions are also available. When used in combination with the schedule timer (optional accessory), timer operation and stop functions are available.



See page 8—12.

■ Various operation modes.

You can operate the system from both this unit and the remote controller, so to enable various operation control patterns. Twenty different operation modes are available including five operation patterns:

1. Start/stop: remote controller prohibition, remote controller stop-only permission, central priority, after-press priority, remote controller permission timer
2. Operation modes: remote controller prohibition, remote controller permission
3. Set temperature: remote controller prohibition, remote controller permission



See page 13—15.

■ Zone control for simpler setting procedures

You can control a maximum of 64 groups of indoor units by using this central remote controller. You don't have to repeat the same setting operations by group because you can make each of the following settings by zone.

A functions is available for setting all groups in one batch.

- Operation mode
- Control mode
- Setting temperature
- Programming time No. (Used in conjunction with the schedule timer)



See page 8—16.

■ Monitoring all indoor unit information

The following information can be displayed by group.

- Operation information such as operation mode, set temperature, etc., for indoor units
- Maintenance information such as cleaning signs for filters or elements
- Error codes and other malfunction diagnosis information



See page 16—21.

■ Function of refrigerant system display

This display helps you understand, at a glance, the indoor units sharing the same outdoor unit and the particular indoor unit among them that is set as the master remote controller.





See page 20.

- Room air conditioners and multi-purpose air conditioners may also be connected by using separately-sold adapter boards.
 This may limit functionality, so consult the manuals that come with each adapter board.

NAMES AND FUNCTIONS OF THE OPERATING SECTION (Fig. 1, 2)

1	UNIFIED OPERATION BUTTON
	Press to operate all indoor units.
2	UNIFIED STOP BUTTON
	Press to stop all indoor units.
3	OPERATION LAMP (RED)
	Lit white any of the indoor units under control is in operation.
4	“REF CIRCUIT” DISPLAY (REFRIGERANT SYSTEM DISPLAY)
	This indication in the square is lit while the refrigerant system is being displayed.
5	“ZONE SET” DISPLAY (ZONE SETTING)
	The lamp is lit while setting zones.
6	“MONITOR” DISPLAY (OPERATION MONITOR)
	The lamp is lit while operation is being monitored.
7	“ALL” “ZONE” “INDIVIDUALLY” DISPLAY
	The status displays indicates either batch functions or which zone or individual unit (or group) are being used.
8	OPERATION MONITOR
	Each square displays the state corresponding to each group.
9	“①” “⌘” “⌘” “⌘” “⌘” “⌘” “⌘” “--” DISPLAY (OPERATION MODE)
	Displays operating state.
10	“⌘” “⌘” “⌘” “⌘” “⌘” DISPLAY (VENTILATION CLEANING DISPLAY)
	This is displayed when a Ventiair total enthalpy heat exchanger unit or other such unit is connected.
11	“⌘TEST” DISPLAY (INSPECTION/TEST)
	Pressing the maintenance/test run button (for service) displays this. This button should not normally be used.
12	“⌘/⌘” DISPLAY (TIME TO CLEAN)
	It lights up when any individual unit (group) has reached the time for the filter or element to be cleaned.

13	“⌘” DISPLAY (COOLING/HEATING SELECTION PRIVILEGE NOT SHOWN)
	For zones or individual units (groups) for which this is displayed, cooling and heating cannot be selected.
14	“HOST” DISPLAY (UNDER HOST COMPUTER INTEGRATED CONTROL)
	While this display is lit up, no settings can be made. It lights up when the upper central machines are present on the same air conditioning network.
15	“SET 88°F” DISPLAY (PRESET TEMPERATURE)
	Displays the preset temperature.
16	“⌘ U4” DISPLAY (MALFUNCTION CODE)
	This displays (flashes) the content of errors when an error failure has occurred. In maintenance mode, it displays the latest error content.
17	“NOT AVAILABLE” DISPLAY (NO FUNCTION DISPLAY)
	If a function is not available in the indoor unit even if the button is pressed, “NOT AVAILABLE” is may be displayed for a few seconds.
18	“⌘” DISPLAY (FAN DIRECTION SWING DISPLAY)
	This displays whether the fan direction is fixed or set to swing.
19	“⌘” “L” “H” “HH” “⌘” “FRESH UP” DISPLAY (VENTILATION STRENGTH/SET FAN STRENGTH DISPLAY)
	This displays the set fan strength.
20	“⌘ No.” DISPLAY (TIME NO.)
	Displays the operation timer No. when used in conjunction with the schedule timer.

21	“CODE UNIT No. 18” DISPLAY (OPERATION CODE AND UNIT NUMBER DISPLAY)
	The method of operation (remote controller prohibited, central operation priority after-press operation priority, etc.) is displayed by the corresponding code. This displays the numbers of any indoor units which have stopped due to an error.
22	“” “” DISPLAY (TIME TO CLEAN AIR CLEANER ELEMENT/TIME TO CLEAN AIR FILTER)
	Displayed to notify the user it is time to clean the air filter or air cleaner element of the group displayed.
23	VENTILATION MODE BUTTON
	This is pressed to switch the ventilation mode of the total enthalpy heat exchanger.
24	ALL/INDIVIDUAL BUTTON
	Pressing this button scrolls through the “all screen”, “zone screen”, and “individual screen”.
25	ARROW KEY BUTTON
	This button is pressed when calling an individual indoor unit or a zone.
26	ON/OFF BUTTON
	Starts and stops ALL, ZONE, and INDIVIDUAL units.
27	TEMPERATURE ADJUSTMENT BUTTON (ZONE NUMBER BUTTON)
	This button is pressed when setting the temperature. Select the zone number if any zones have been registered.
28	FAN DIRECTION ADJUSTMENT BUTTON
	This button is pressed when setting the fan direction to “fixed” or “swing”.
29	OPERATION MODE SELECTOR BUTTON
	This sets the operation mode. The dry setting cannot be done.
30	TIME NO. BUTTON
	Selects time No. (Use in conjunction with the schedule timer only).
31	CONTROL MODE BUTTON
	Selects control mode.
32	FILTER SIGN RESET BUTTON
	This button is pressed to erase the “clean filter” display after cleaning or replacement.

33	SET BUTTON
	Sets control mode and time No.
34	FAN STRENGTH ADJUSTMENT BUTTON
	Pressing this button scrolls through “weak”, “strong”, and “fast”.
35	ZONE SETTING BUTTON
	Zone registration mode can be turned on and off by pressing the start and stop buttons simultaneously for at least four seconds.
36	INSPECTION/TEST RUN BUTTON (FOR SERVICE)
	Pressing this button scrolls through “inspection”, “test run”, and “system display”. This button is not normally used.
37	VENTILATION STRENGTH ADJUSTMENT BUTTON
	This button is pressed to switch the ventilation strength (“fresh up”) of the total enthalpy heat exchanger.

(Notes)

1. Please note that all the displays in the figure appear for explanation purposes or when the cover is open.
2. If the unit is used in conjunction with other optional central controllers, the OPERATION LAMP of the unit that is not under operation control may light up and go out a few minutes behind schedule. This shows that the signal is being exchanged, and does not indicate any failure.

OPERATION

■ **Individual screen, all screen, zone screen (Fig. 3)**

This controller can perform operations in the individual screen, all screen, or zone screen.

- Individual screen The individual screen is used when performing group operations.
- All screen The all screen is used when performing operations for all units at once.
- Zone screen The zone screen is used when performing zone operations.

1.  Select the screen by pressing the “ALL/INDIVIDUAL” button.



 Every time the “ALL/INDIVIDUAL” button is pressed, the selection scrolls through INDIVIDUAL → ALL → ZONE.
If nothing is done in the all or zone screens for one minute, it automatically goes to the individual screen.

- If the zone number in the zone screen is displayed as “--,” this indicates that no units are registered in a zone.
Please perform zone registration before proceeding in the zone screen. (See page 9)

■ Batch operation and stop method (Fig. 4)

This is for operating or stopping all connected units at once.

A. What to do when operating or stopping all connected units at once.

1. Press either  “ALL I” or  “ALL O”.

- Operation can be performed from the individual screen, the all screen, or the zone screen.
- The “TEMPERATURE ADJUSTMENT” and “OPERATION MODE SELECTOR” buttons cannot be used.
To set the temperature and operation mode, use B. batch operation.

B. Batch Operation

1.  Press the “ALL/INDIVIDUAL button” to enter the all screen.

The “” display lights up on all registered units.

2.  Press the “SELECT” button.



The “” display lights up on all connected units.

3.  Press the “RESET” button.

The “” display goes off on all connected units.

Operation and stop in the batch screen are done the same as with the batch operation and batch stop buttons.

3.  Press the “TEMPERATURE ADJUSTMENT” button.

The temperature rises 1° every time the () button is pressed.
The temperature drops 1° every time the () button is pressed.

Set to “--” when you do not wish to use batch setting for the temperature setting.
Setting to 1° above or below the temperature setting range displays “--”.

4.  Call up the desired mode by pressing the “OPERATION MODE SELECTOR” button.

Set to “--” when you do not wish to use batch setting for the operation setting.



■ Group operation and stop method (Fig. 5)

This is for operating or stopping connected units in groups.

[Group operation]

1. Press the  “ALL/INDIVIDUAL button” to enter the  individual screen.

The unit will enter the individual screen automatically if nothing is done for one minute.

2.  Using the arrow keys,  move the “” to select the units to operate or stop.

Keeping the button pressed down will move it rapidly.

The “” in this screen has selected unit 1-04.

3.  Press the “SELECT” button.

The “” display lights up in the group.

4.  Press the “RESET” button.

The “” display goes off in the group.

4.  Press the “TEMPERATURE ADJUSTMENT” button.

The temperature rises 1° every time the () button is pressed.

The temperature drops 1° every time the () button is pressed.

Temperature adjustment cannot be done if the selected group’s air conditioners are in fan mode.

5.  Call up the desired mode by pressing the “OPERATION MODE SELECTOR” button.

■ Registering zones (Fig. 6)

It is possible to set multiple groups as one zone and control each zone separately.

No zones are registered when the unit is shipped from the factory.

Zone registration can be done in the individual screen, all screen, or zone screen.

[Registration]

1.  Pressing the “ALL/INDIVIDUAL” button for four seconds.  Displays ZONE SET.

Zone Number 1 will be displayed, and if there are any groups already registered in the displayed zone, a “” will light up on the operation monitor.

2. Select the Zone Number to be registered using the “ZONE NUMBER” button. Keeping the button pressed down will move it rapidly.
3. “” to the group you wish to register using the arrow keys. Keeping the button pressed down will move it rapidly.
4. Press the “SELECT” button to register that group to the zone.
The “” display lights up on all the selected units.
 Pressing the “RESET” button removes the group from that zone, and “” goes off.

Repeat steps 3 and 4 until all the units you wish to register to the zone have been added.

	00	01	02	03	04	05	06	07	08	09	10	11	12	13	14	15
1-	■		■	■												
2-	■															
3-																
4-																

In this example, a screen is shown with units 1-00, 1-02, 1-03, and 2-00 registered to Zone Number 1.

5. Repeat steps 2 to 4 to register to the next zone.
6. Once zone registration is complete, press the “ALL/INDIVIDUAL” button to turn off “ZONE SET” display and return to the individual screen.
The display returns to the normal screen if nothing is done for one minute when in zone registration mode.

(NOTE)

- It is impossible to register one group to several different zones.
If this is done, the last zone registered to will be valid.

[Batch deletion of zone registration]

1. Pressing the “ALL ○” for at least four seconds while pressing the “FILTER SIGN RESET” button when “ZONE SET” is displayed will delete all zone registrations.
The zone registrations for all units will be lost.

■ Zone operation and stop method (Fig. 7)

This is for operating or stopping connected units in zones.

[Zone operation]

1. Press the “ALL/INDIVIDUAL button” to enter the zone screen.
2. Using the arrow keys, select the zone number to operate or stop.

Pressing and reduces the zone number while and raise the number. Keeping the button pressed down will move it rapidly.

- If the zone number is displayed as “--,” this indicates that no units are registered in a zone. Please perform zone registration before using a zone. (See page 9)

3. Press the “SELECT” button.

The “” display lights up in the group.

4. Press the “RESET” button.

The “” display goes off in the group.

4. Press the “TEMPERATURE ADJUSTMENT” button.

The temperature rises 1° every time the (▲) button is pressed.

The temperature drops 1° every time the (▼) button is pressed.

Set to “--” when you do not wish to use zone setting for the temperature setting.

Setting to 1° above or below the temperature setting range displays “--”.

5. Call up the desired mode by pressing the “OPERATION MODE SELECTOR” button.

Set to “--” when you do not wish to use zone setting for the operation mode.

■ Changing the fan direction and fan strength (Fig. 8)

This changes the fan direction and strength settings in the air conditioner.

Changing the fan direction and strength is done in the individual screen.

[Registration]

1. Press the “ALL/INDIVIDUAL button” to enter the individual screen.

The unit will enter the individual screen automatically if nothing is done for one minute.

2. Using the arrow keys, move the “” to select the units to fan direction adjustment or fan strength adjustment.

Keeping the button pressed down will move it rapidly.

3. Press the “FAN DIRECTION ADJUSTMENT” button.

This sets “fixed” or “swing” for the fan direction.

1. Press the “FAN STRENGTH ADJUSTMENT” button.

Pressing this button scrolls through “”, “”, and “”.

Depending on the indoor unit, only “” and “” may be available.

The functions included in the indoor units may vary. Pressing a button for a function which is not available will cause “NOT AVAILABLE” to be displayed.

■ Changing the ventilation mode and ventilation strength (Fig. 9)

This changes the ventilation mode and strength settings in the total enthalpy heat exchanger.

Changing the ventilation mode and strength is done in the individual screen.

[Registration]

1. Press the “ALL/INDIVIDUAL button” to enter the individual screen.

The unit will enter the individual screen automatically if nothing is done for one minute.

2. Using the arrow keys, move the “” to select the units to ventilation mode or ventilation strength adjustment.

Keeping the button pressed down will move it rapidly.

3. Press the “VENTILATION MODE” button.

It will scroll through “” → “” → “” → “”.

1. Press the “VENTILATION STRENGTH ADJUSTMENT” button.

It will scroll through “” → “” → “” →

“” → “”.

The fresh up function may not be available depending on the connected unit model.

The functions included in the indoor units may vary. Pressing a button for a function which is not available will cause “NOT AVAILABLE” to be displayed.

• Ventilation Mode and Amount

If these are changed using the remote controller depending on the unit model, they cannot be displayed on the central remote controller.

To monitor the ventilation mode and amount, check the values on the remote controller.

■ Timer Number Setting (Fig. 10)

(Only when used with the schedule timer)

Using this together with the schedule timer makes it possible to set on and off times four times a day.

[Registration]

1. Pressing the “TIMER NO.” button causes the number set for timer number 1 to blink.

If no timer setting has been made “-” will be displayed.

Select the desired timer number by pressing the “TIMER NO.” button.

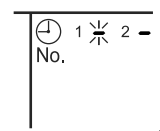

2. Once the desired timer number is displayed, press the “SET” button.

Press the “SET” button within 10 seconds after the timer number is displayed.

The display will return to how it was after 10 seconds.

The display for timer number 1 will stop blinking and then timer number 2 will start blinking.

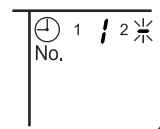

3.  Select the desired timer number by pressing the “TIMER NO.” button.

Once the desired timer number is displayed,  press the “SET” button.
The display for timer number 2 will stop blinking.

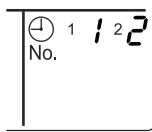

The “ No.” display will disappear after 3 seconds.

Select “-” in the timer number when you do not wish to set a timer number.
It is possible to set only one timer number.
(The times for turning the unit(s) on and off twice a day can be set with a single timer number.)

• Timer Number Setting

- Group control: select the unit in the individual screen and set the timer number.
- Batch control: set the timer numbers for all connected units.
- Zone control: set the timer numbers for all zone-registered units.
Call up the zones which you wish to set in the zone screen and set the timer numbers.

• Since the timer number will be set to after-press priority, the timer number in the last screen set will be valid for the connected units.

Example 1
Setting timer number 1 for unit 1-00 to “1” and timer number 2 to “2” in the individual screen and then setting timer number 1 to “3” and timer number 2 to “4” in the batch screen causes the timer numbers for all units to be set, so timer number 1 for unit 1-00 will be “3” and timer number 2 will be “4”.

Example 2
To prevent leaving units on, timer number 1 is set to “5” in the batch screen.
Setting timer number 1 in zone number 1 to “-” in the zone screen after that will change the timer number for zone number 1, so the setting to prevent leaving the units on will be lost for zone number 1 only.

If a timer number is set incorrectly by accident, redo the setting in the desired screen.

• What happens when the timer number on time and off time are set to the same time

When the on time and off time are set to the same time for the same timer number, operation does not change.
When the on time and off time are set to the same time for different timer numbers, the off time is given priority.

When using timer operation, make sure the times do not overlap when setting the program of the schedule timer.

■ Setting the Operation Code (Fig. 11)

[Registration]

1.  Pressing the “CONTROL MODE” button causes the currently set operation code to blink.

Call up the desired code number by pressing the  “CONTROL MODE” button.
Scroll through the code numbers.

2.  Once the code number is displayed, press the “SET” button.

The display will stop blinking.
The operation code display will disappear after 3 seconds.

[The Operation Code Setting]

- Group control: select the unit in the individual screen and set the operation code.
- Batch control: set the operation code for all connected units.
- Zone control: set the operation code for all zone-registered units.
Call up the zones which you wish to set in the zone screen and set the operation code.

Since the operation code will be set for after-press priority, setting the operation code in the zone and individual screens after setting the operation code in the batch screen, will cause the operation codes set afterwards to be valid.

OPERATION MODE

The following five operation control modes can be selected along with the temperature setting and operation mode by remote controller, for a total of twenty different modes. These twenty modes are set and displayed with control modes of 0 to 19. (For further details, see **EXAMPLE OF OPERATION SCHEDULE** on the next page.)

- ON/OFF control impossible by remote controller..... Use this mode when operating and stopping from the central remote controller only. (ON/OFF control by the remote controller is disabled.)
- Only OFF control possible by remote controller Use this mode when executing the operation only by the central remote controller, and executing only the stop by remote controller.
- Centralized Use this mode when executing the operation only by the central remote controller, and executing start/stop freely by remote controller during the preset hours.
- Individual Use this mode when executing start/stop both by central remote controller and remote controller.
- Timer operation possible by remote controller..... Use this mode when executing start/stop by remote controller during the preset hours, and not starting operation by the central remote controller at the programmed time of system start.

[HOW TO SELECT THE CONTROL MODE]

- Select whether to accept or to reject the operation from the remote controller regarding the operation, stop, temperature setting and operation mode setting, respectively, and determine the particular control mode from the rightmost column of the table below.

Example

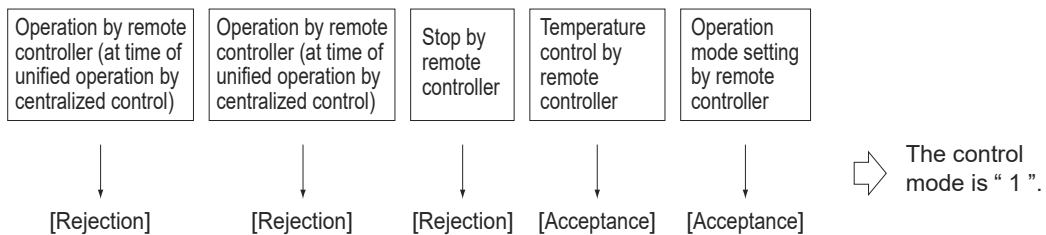

Operation mode	Control by remote controller					Control mode
	Operation		Stop	Temperature control	Operation mode setting	
	Unified operation, individual operation by central remote controller, or operation controlled by timer	Unified stop, individual stop by central remote controller, or timer stop				
ON/OFF control impossible by remote controller	Rejection (Example)	Rejection (Example)	Rejection (Example)	Rejection	Acceptance	0
Only OFF control possible by remote controller				Acceptance (Example)	Rejection	10
Centralized	Acceptance	Acceptance	Acceptance	Rejection	Acceptance	2
Individual				Acceptance	Rejection	12
Timer operation possible by remote controller	Acceptance (During timer at ON position only)	Rejection (During timer at OFF position)	Acceptance	Rejection	Acceptance	3
				Acceptance	Rejection	13
	Acceptance	Acceptance	Acceptance	Rejection	Acceptance	4
				Acceptance	Rejection	14
	Acceptance	Acceptance	Acceptance	Rejection	Acceptance	5
				Acceptance	Rejection	15
	Acceptance	Acceptance	Acceptance	Rejection	Acceptance	6
				Acceptance	Rejection	16
	Acceptance	Acceptance	Acceptance	Rejection	Acceptance	7
				Acceptance	Rejection	17
	Acceptance	Acceptance	Acceptance	Rejection	Acceptance	8
				Acceptance	Rejection	18
	Acceptance	Acceptance	Acceptance	Rejection	Acceptance	9
				Acceptance	Rejection	19

Note) Do not select the timer operation possible without the remote controller. In this case, timer operation is disabled.

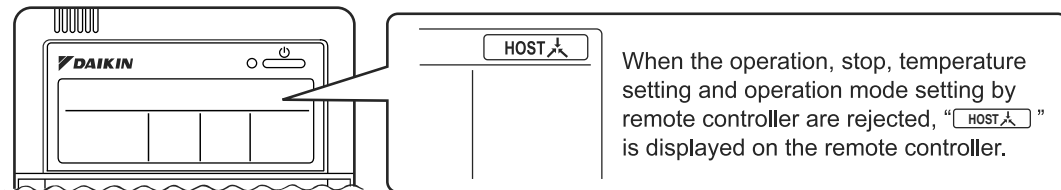

EXAMPLE OF OPERATION SCHEDULE

Operation schedule is possible only in conjunction with the schedule timer (optional accessory).

Liquid crystal display of schedule timer

ON/OFF control impossible by remote controller

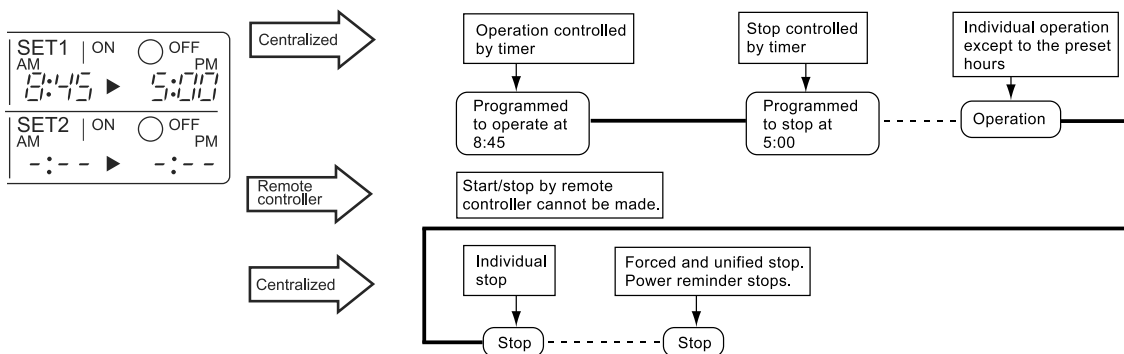

Only OFF control possible by remote controller

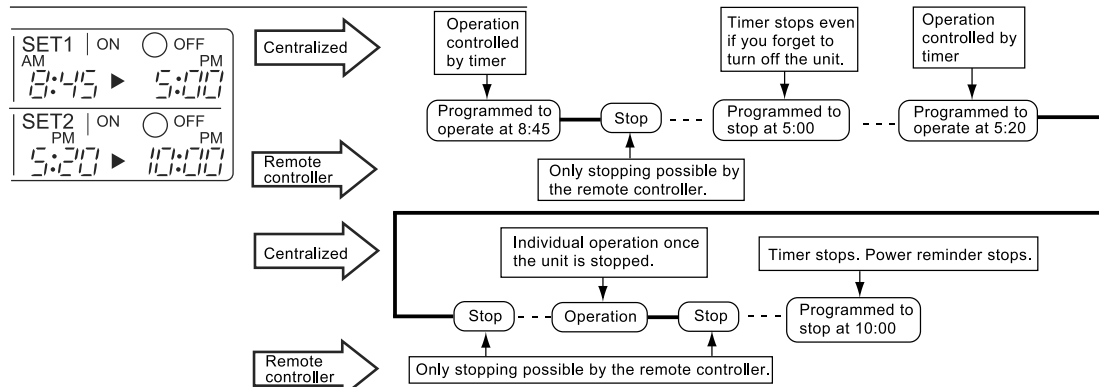

Centralized

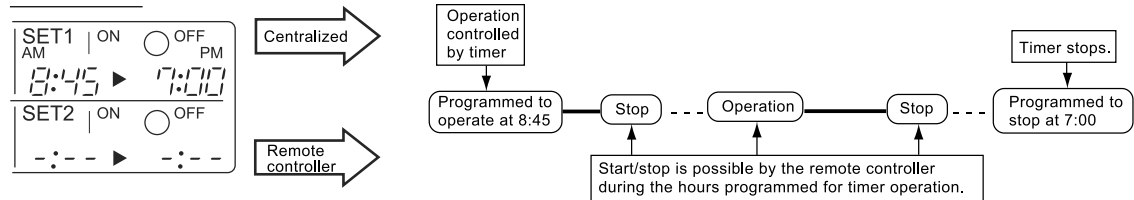

Individual

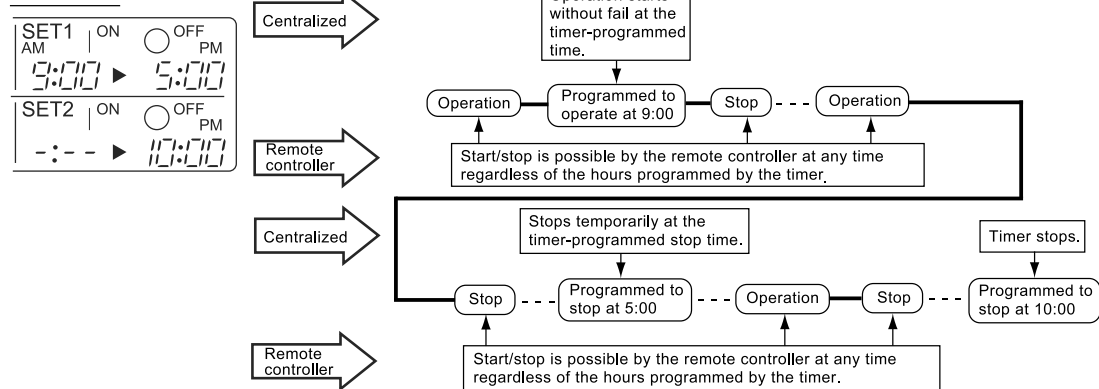

Timer operation possible by remote controller

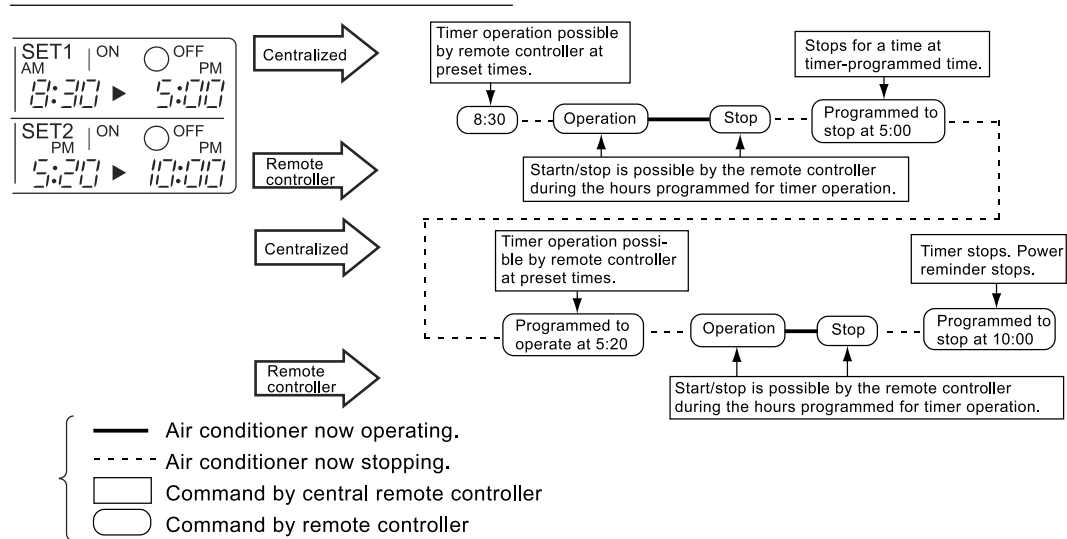

- Air conditioner now operating.
- - - - Air conditioner now stopping.
- ▭ Command by central remote controller
- Command by remote controller

■ **Setting operation mode (Fig. 12)**

[Registration]

1. Press the **OPERATION MODE SELECTOR BUTTON**. Each time you press this button, the display rotates as shown on the below list.

• **List of operations which can be set**

In the below list, “○” refers to the acceptable setting, while “x” refers to the not acceptable setting.

Display	A: Zones and groups with no “ ” display.	
	Setting	Contents of setting
	x	
	○	Can be set in individual zones or groups
	○ * 1	Can be set in individual zones or groups
	○	Can be set in individual zones or groups
	○	Can be set in individual zones or groups
	○ * 1	Can be set in individual zones or groups * 3
	○ * 1	Can be set in individual zones or groups
	○	Select this display if you don't wish to set by zone.

Display	B: Zones and groups with a “ ” display.	
	Setting	Contents of setting
	○	To be set by zone * 2
	○	Can be set in individual zones or groups
	x	
	x	The displays are shown by group * 4
	x	The displays are shown by group * 4
	○ * 1	Can be set in individual zones or groups * 3
	○ * 1	Can be set in individual zones or groups
	○	Select this display if you don't wish to set by zone.

- *1: Setting may not be acceptable depending on the type of indoor unit with which this unit is connected.
- *2: In zone control, the units run in temperature adjustment mode (heating or cooling) for the outdoor system for the groups registered to those zones. Heating or cooling selection is not available.
- *3: Changing the ventilation mode cannot be done in the zone screen. Changing the ventilation mode should be done in the individual screen.
- *4: In group control, the units run in temperature adjustment mode (heating or cooling) for the group outdoor system. Heating or cooling selection is not available.

• **The Zone consists of the following two cases.**

A. Zone without display “ ”
 The group with master remote controller setting exists in this zone.
 Setting the master remote controller enables cool/heat selection.
 Operations other than cool/heat operations can also be set for some operations. For further details, see the list on the left.

B. Zone with display “ ”
 No group with master remote controller setting exists in this zone.
 The cool/heat selection is not available because the master remote controller has not been set.
 Some operations other than cool/heat operations can be set. For further details, see the list in the left.

See page 20 if the display “ ” is flashing.

- Fan operation can be performed for each zone using the central remote controller even if there is no cooling/heating selection right during cooling or heating. Also, if a VentiAir is connected in the zone, ventilation and ventilation cleaning operation is possible. See the included operating manuals for details.
- When the indoor unit is in heat operation, change the setting to FAN operation through the central remote controller; then, you can switch the fan speed to the extremely low fan speed. Warm air may blow if any other indoor unit belonging to the same system is in heat operation.
- The indoor fan stops during defrost/hot start.
- DRY cannot be set from the central remote controller.

■ **Group monitoring (Fig. 13)**

Utilize the group monitor function in each of the following cases:

1. Check the malfunction code. (See the next page.)
2. Check the group that requires cleaning of the air filter and air cleaner element. (See page 21.)
3. Change the setting of the master remote controller. (See page 20.)
4. Check the group(s) sharing the same outdoor unit. Or, check the particular group(s) with the master remote controller setting. (See page 20.)
5. Check the conditions of other individual groups.

When in zone screen

The zone screen will revert to the individual screen automatically if nothing is done in it for one minute.

[Registration]

1. Press the “ALL/INDIVIDUAL” button to switch to the “INDIVIDUAL” screen.

2. Using the arrow key, move the “ ” to select the unit to be monitored.

Keeping the button pressed down will move it rapidly.

The “ ” lights up and the status of that unit is displayed in the LCD. The cursor in the screen Fig. 13 has selected unit 2-06.

■ Error diagnosing function

(Fig. 14)

This central remote controller is provided with a diagnosing function, for when an indoor unit stops due to malfunction. In case of actuation of a safety device, disconnection in transmission wiring for control or failure of some parts, the operation lamp, inspection display and unit No. start to flash; then, the malfunction

code is displayed. Check the contents of the display, and contact your DAIKIN dealer because the above signs can give you the idea on the trouble area.

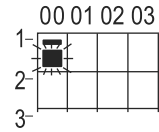

The display “ ” flashes under the group No. where the indoor unit that has stopped due to malfunction.

[Registration]

1. Press the ARROW KEY BUTTON to call up the group that has stopped due to malfunction.

The unit No. the malfunction code is flashing because of an error failure.

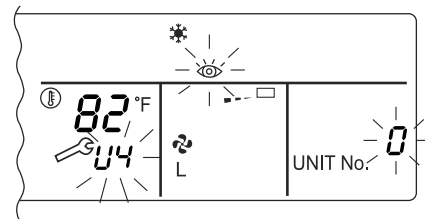

Operation lamp	Maintenance display	Unit No.	Malfunction code	Error content
☀	●	⚡	64	Indoor air thermistor error
☀	●	⚡	65	Outdoor air thermistor error
☀	●	⚡	68	HVU error (Ventiair dust-collecting unit)
☀	●	⚡	6A	Dumper system error
⚡	⚡	⚡	6A	Dumper system error + Thermistor error
☀	●	⚡	6F	Simple remote controller error
☀	●	⚡	6H	Door switch (Ventiair dust-collecting unit), relay harness fault (Ventiair dust-collecting/humidifier unit)
⚡	⚡	⚡	94	Ventiair internal transmission error (between total enthalpy – fan unit)
⚡	⚡	⚡	A0	Indoor unit · external safety device error
⚡	⚡	⚡	A1	Indoor unit · BEV unit (Sky-Air connection unit) PC board assembly fault
☀	●	⚡	A1	Indoor unit · PC board assembly fault
⚡	⚡	⚡	A3	Indoor unit · Drain level error (33H)
⚡	⚡	⚡	A6	Indoor unit · Fan motor (51F) lock, overload
☀	●	⚡	A7	Indoor unit · Fan direction adjustment motor (MA) error
⚡	⚡	⚡	A9	Indoor unit · BEV unit, electric expansion valve motor (20E) error
☀	●	⚡	AF	Indoor unit · Malfunctioning drain
☀	●	⚡	AH	Indoor unit · Dust-collector error
⚡	⚡	⚡	AJ	Indoor unit · Insufficient capacity setting, address setting fault

☼	☼	☼	C4	Indoor unit · Liquid piping thermistor (Th2) Error (faulty connection, cut wire, short circuit, fault)
☼	☼	☼	C5	Indoor unit · BEV unit, gas piping thermistor (Th3) Error (faulty connection, cut wire, short circuit, fault)
☼	☼	☼	C9	Indoor unit · Intake air thermistor (Th1) Error (faulty connection, cut wire, short circuit, fault)
☼	☼	☼	CA	Indoor unit · Outlet air thermistor (Th4) Error (faulty connection, cut wire, short circuit, fault)
☼	●	☼	CJ	Indoor unit · remote controller sensor error
☼	☼	☼	E0	Outdoor unit · Safety device operation
☼	☼	☼	E1	Outdoor unit · PC board assembly fault
☼	●	☼	E1	Outdoor unit · PC board assembly fault
☼	☼	☼	E3	Outdoor unit · High-pressure switch fault
☼	☼	☼	E4	Outdoor unit · Low-pressure switch fault
☼	☼	☼	E9	Outdoor unit · Electric expansion valve motor (20E) error
☼	●	☼	EC	Heat source unit · Intake water temperature inter-lock operation (fan operation)
☼	☼	☼	EF	Outdoor unit · Ice thermal storage unit error
☼	☼	☼	F3	Outdoor unit · Discharge piping temperature error
☼	●	☼	H3	Outdoor unit · High-pressure switch operation
☼	☼	☼	H4	Outdoor unit · Low-pressure switch operation
☼	☼	☼	H9	Outdoor unit · Outdoor air thermistor (Th1) Error (faulty connection, cut wire, short circuit, fault)
☼	●	☼	H9	Outdoor unit · Outdoor air thermistor (Th1) Error (faulty connection, cut wire, short circuit, fault)
☼	●	☼	HC	Outdoor unit · Water temperature sensor system error
☼	●	☼	HF	Ice thermal storage unit error, ice thermal storage controller error, error in outdoor unit during ice thermal storage operation
☼	☼	☼	HJ	Outdoor unit · water system fault
☼	☼	☼	J1	Outdoor unit · pressure sensor error
☼	☼	☼	J3	Outdoor unit · Discharge piping thermistor (Th3) Error (faulty connection, cut wire, short circuit, fault)
☼	●	☼	J3	Outdoor unit · Discharge piping thermistor (Th3) Error (faulty connection, cut wire, short circuit, fault)
☼	☼	☼	J5	Outdoor unit · Intake piping thermistor (Th4) Error (faulty connection, cut wire, short circuit, fault)
☼	☼	☼	J6	Outdoor unit · Heat exchange thermistor (Th2) error
☼	●	☼	J6	Outdoor unit · Heat exchange thermistor (Th2) error Error (faulty connection, cut wire, short circuit, fault)
☼	☼	☼	J7	Outdoor unit · Header thermistor (Th6) error
☼	☼	☼	JA	Outdoor unit · Discharge piping pressure sensor error
☼	☼	☼	JC	Outdoor unit · Intake piping pressure sensor error
☼	☼	☼	JF	Outdoor unit · Oil temperature sensor (Th5) system error
☼	●	☼	JH	Outdoor unit · Oil temperature sensor (Th5) system error
☼	☼	☼	L0	Outdoor unit · Inverter system fault
☼	☼	☼	L4	Outdoor unit · Inverter cooler fault
☼	☼	☼	L5	Outdoor unit · Ground circuit for compressor motor, short circuit, or power unit short circuit

☼	☼	☼	L6	Outdoor unit · Ground circuit for compressor motor, short circuit
☼	☼	☼	L8	Outdoor unit · Compressor overload, compressor motor wire disconnection
☼	☼	☼	L9	Outdoor unit · Compressor lock
☼	☼	☼	LA	Outdoor unit · Power unit error
☼	☼	☼	LC	Outdoor unit · Transmission error between inverter and outdoor control unit
☼ or ●	☼	☼	M1	Central controller: PC board fault
☼ or ●	☼	☼	M8	Transmission error between central controllers
☼ or ●	☼	☼	MA	Central controller: Incorrect combination
☼ or ●	☼	☼	MC	Central controller: Address setting fault
☼	●	☼	P0	Insufficient gas (thermal storage)
☼	☼	☼	P1	Outdoor unit · Power voltage imbalance, phase loss
☼	☼	☼	P4	Outdoor unit · Power unit temperature sensor error
☼	●	☼	U0	Pressure drop due to insufficient refrigerant, electric expansion valve fault, etc.
☼	☼	☼	U1	Reversed or lost phase
☼	☼	☼	U2	Power voltage error, momentary electrical stoppage
☼	☼	☼	U4	Transmission error between indoor unit/BEV unit and outdoor/BS unit, Transmission error between outdoor unit and BS unit
☼	☼	☼	U5	Transmission error between remote controller and indoor control unit
●	☼	●	U5	Remote controller board fault or remote controller setting fault
☼	☼	☼	U6	Transmission error between indoor units
☼	☼	☼	U7	Transmission error between outdoor units Transmission error between outdoor unit and ice thermal storage unit
☼	●	☼	U7	Transmission error between outdoor units (cooling/heating batch, low-noise operation)
☼	☼	●	U8	Transmission error between master remote controller and slave remote controller (slave remote controller error) Incorrect combination of indoor unit and remote controller within a single system (model)
☼	☼	☼	U9	Transmission error between indoor unit/BEV unit and outdoor unit within a single system Transmission error between BS unit and indoor unit/BEV unit and outdoor unit within a single system
☼	☼	☼	UA	Incorrect combination of indoor, BS, and outdoor units within a single system (model, number of units, etc.) Incorrect combination of indoor unit and remote controller (remote controller in question) BS unit connection position fault
☼	●	☼	UC	Central control group numbers overlap
☼	☼	☼	UE	Transmission error between indoor unit and central controller
☼	☼	☼	UF	Unset system, incorrect settings between BEV unit and indoor unit
☼	☼	☼	UH	System fault

■ error codes (in outline font) do not display “maintenance” and the system will run, but please check the content of the display and contact your dealer.

■ Setting master remote controller (Fig. 15)

You must set the master remote controller of the operation mode for one of the indoor units, if two or more such indoor units with the remote controller are connected with the outdoor unit where the operation modes such as cool/heat operation and FAN operation can be set by remote controller and central remote controller.

1. Preparations

When you want to fix settings

- Check the particular group with the master remote controller setting for the refrigerant system you wish to reset. (See the below.)
- Call up the group without the display “” (See page 16.)

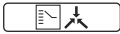

 Hold the OPERATION MODE SELECTOR BUTTON down for about four seconds while the above group is being called up.

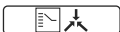
The display “” flashes on the liquid crystal display of the remote controller for all the groups sharing the same outdoor unit or BS unit.

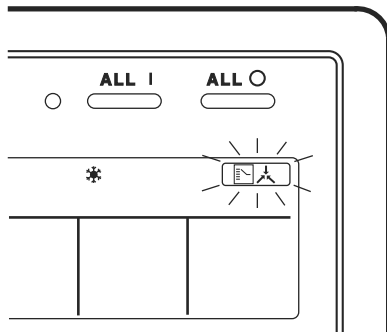
When you turn on the power switch for the first time, the display “” flashes.

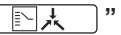

2. Setting selection right

Call up the desired group to set the master remote controller, and  press the OPERATION MODE SELECTOR BUTTON. The master remote controller is set for this group, and the display “” goes out. The display “” appears for the other groups. Setting is finished now.





When switching operation

- In case of operation switch



Call up the zone including the group with the setting of master remote controller.

(Zone without the display “”)

 Press the OPERATION MODE SELECTOR BUTTON several times, and switch to the desired operation mode.

Each time you press it, the display is switched to “” “” “” and “” in sequence.

NOTE

- However, the displays “” “” and “VENTILATION MODE” may appear in some zones, depending on the type on indoor unit with which they are connected.

(VENTILATION MODE)



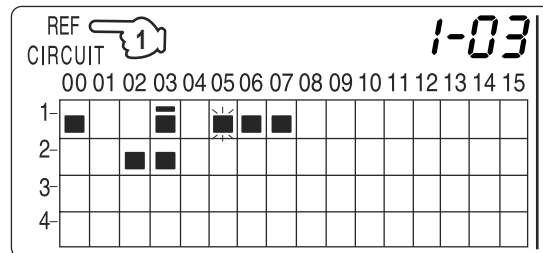

[System Display]

1. Test run mode is necessary to display the system display.
2. In order to turn on test run mode, select the appropriate air conditioner on the individual screen with the cursor and then set its operation mode to either cooling or heating. (It makes no difference if the air conditioner is running or not running while this operator is being performed.)
3. Press the “inspection/test run” button twice to put it into test run mode.
4. Pressing the “inspection/test run” button for four or more seconds in test run mode will display  the “REF CIRCUIT.”



Call the unit whose system you wish to look up using the arrow keys.

The “” on all groups in the same system as the displayed group will light up.

Of those, the “” display in all groups which have cooling/heating selection privilege will blink.

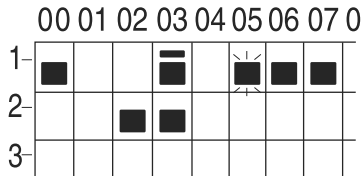

In this example, individual units 1-00, 1-03, 1-05, 1-06, 1-07, 2-02, and 2-03 are in the same system, and 1-05 has the cooling/heating selection privilege.

To look up other systems, call up all the units you wish to look up using the arrow keys.

Pressing the inspection/test run button one more time gets rid of the system display and ends it.

The unit will enter the individual screen automatically if nothing is done for one minute in the system display screen.



This function may not be available for all connected outdoor units, in which case “REF CIRCUIT” will blink. It will also not be correctly displayed if DIII-NET extension ADP is used.

■ Display of time to clean (Fig. 16)



This central remote controller displays the time to clean the air filter or air cleaner element for each group or any given group by utilizing two types of signs. The display “” tells the time to clean the air filter or the air cleaner element of some group.

If a cleaning sign is displayed

A filter or element in some group is ready to be cleaned.



1.  Press the **ARROW KEY BUTTON**, and search the groups displaying “” or “” (The group may be plural.)

Clean or change the air filter or air cleaner element.

For further details, see the operation manual attached to each indoor unit. (Clean or change the air filter or air cleaner element of all the groups displaying “” or “”.)

2.  Press the **FILTER SIGN RESET BUTTON**, and the display “” disappears. (Including all the groups where the air filter has been cleaned.)

NOTE

Be sure to check the display “” “” has disappeared at this point. The appearance of the above display is a sign that the air filter or air cleaner element of some group still needs cleaning.

INSTALLATION TABLE

When installing the equipment, mark the zone No. of each group and installation location in the below table.

Setting group No.

(Setting is not possible unless power is activated to both the central remote controller and indoor unit.)

Operated by remote controller

1. Activate power to both the central remote controller and indoor unit.
2. While in the normal mode, hold down the “

Operated by simplified remote controller

1. Activate power to both the central remote controller and indoor unit.
2. Remove the upper part of the remote controller.
3. Press the **BS6** BUTTON (field set) on the PC board. The controller will enter the FIELD SET MODE.
4. Select the MODE No. “

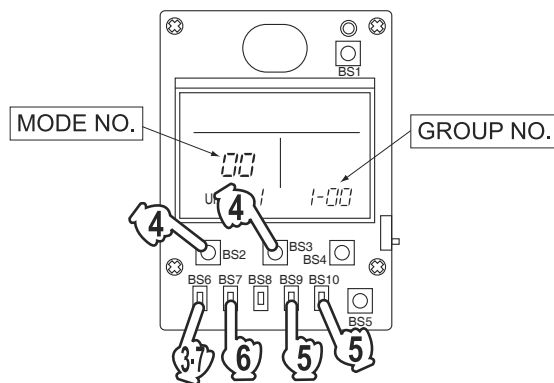

Zone No.																
Group No.	-00	-01	-02	-03	-04	-05	-06	-07	-08	-09	-10	-11	-12	-13	-14	-15
Indoor unit Quantity of units Controlled by																
Location																
Zone No.																
Group No.	-00	-01	-02	-03	-04	-05	-06	-07	-08	-09	-10	-11	-12	-13	-14	-15
Indoor unit Quantity of units Controlled by																
Location																

Zone No.																
Group No.	-00	-01	-02	-03	-04	-05	-06	-07	-08	-09	-10	-11	-12	-13	-14	-15
Indoor unit Quantity of units Controlled by																
Location																
Zone No.																
Group No.	-00	-01	-02	-03	-04	-05	-06	-07	-08	-09	-10	-11	-12	-13	-14	-15
Indoor unit Quantity of units Controlled by																
Location																

OPTIONAL ACCESSORIES

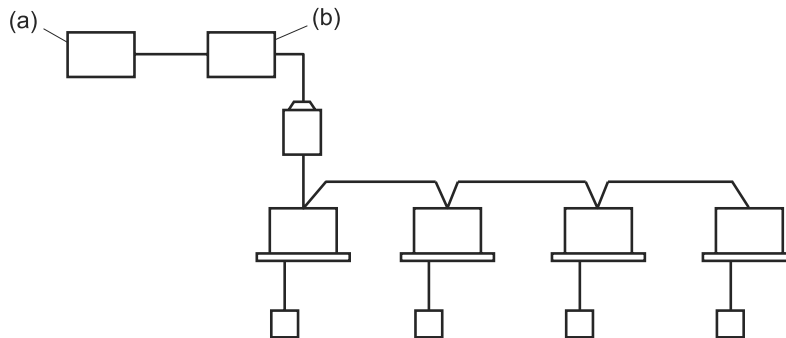

You can perform the normal operation, take off the malfunction contact point and unified start/stop by contact point, all by connecting this unit with the unification adaptor for computerized control. For further details, ask your DAIKIN dealer.

(a) Unification adaptor for computerized control (b) Central remote controller

DOUBLE CENTRAL REMOTE CONTROLLERS

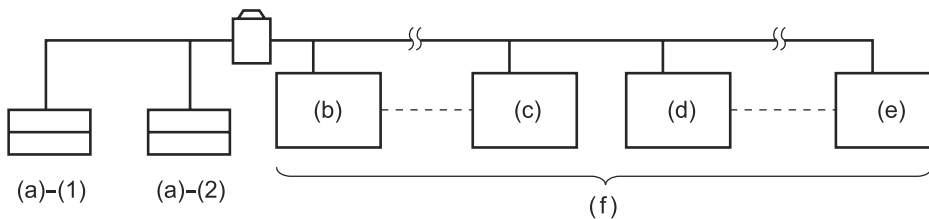

With two central remote controllers, centralized control (indoor units) is possible from different locations.

(a) Central remote controller (b) Group No. 1 - 00 (c) Group No. 1 - 15 (d) Group No. 2 - 00
 (e) Group No. 4 - 15 (f) A maximum of 64 groups

Note)

- For control alignment and settings for double central remote controllers, contact your dealer.

SPECIFICATIONS

■ Specifications

Power supply	1 ~ 50/60Hz, 100V – 240V
Power consumption	Max. 8W
Forced ON/OFF input	Continuous "a" contact Contact current: approximately 10mA
Size	180 (W) × 120 (H) × 64.5 (D)
Weight	420g

■ Outline drawings

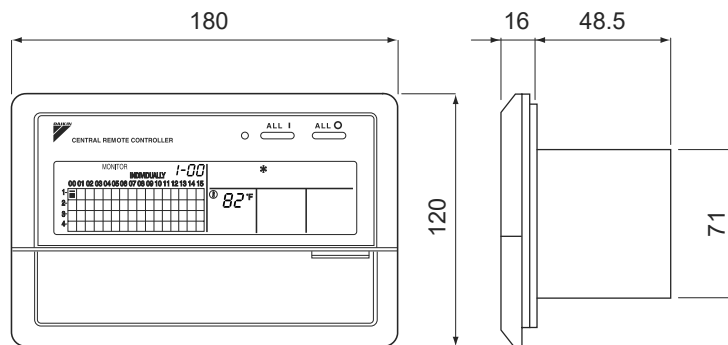

When using this unit an electric parts box of KJB311A is required.
For installation, a steel electric parts box to be embedded is mandatory.

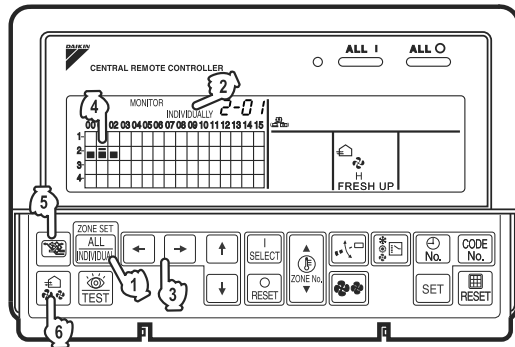

Fig. 9

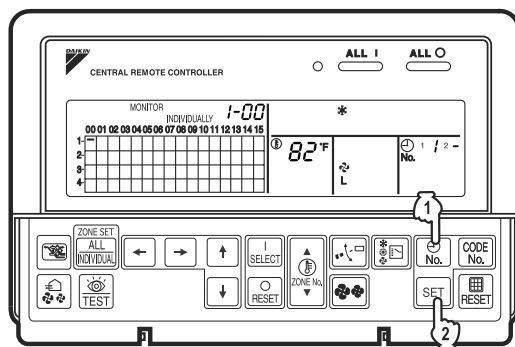

Fig. 10

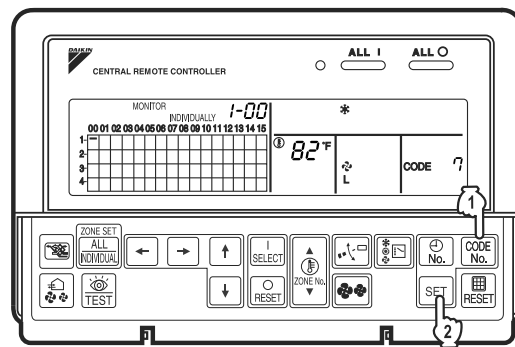

Fig. 11

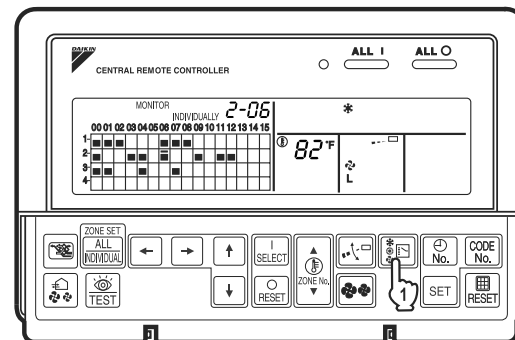

Fig. 12

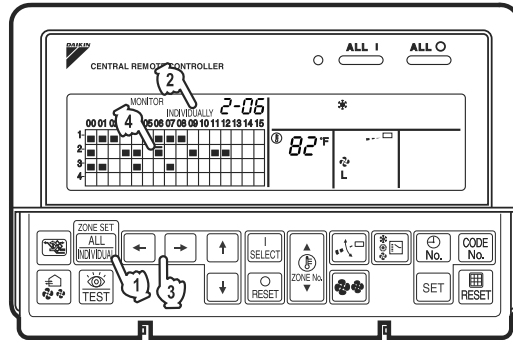

Fig. 13

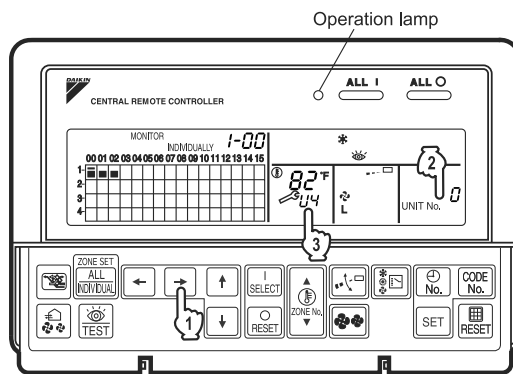

Fig. 14

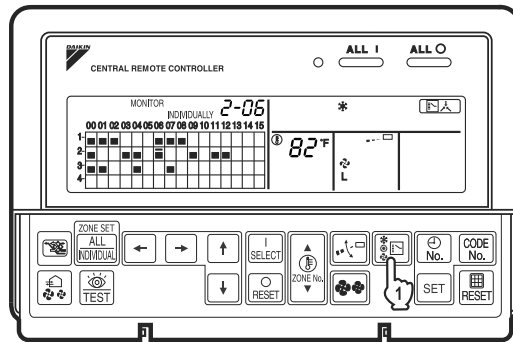

Fig. 15

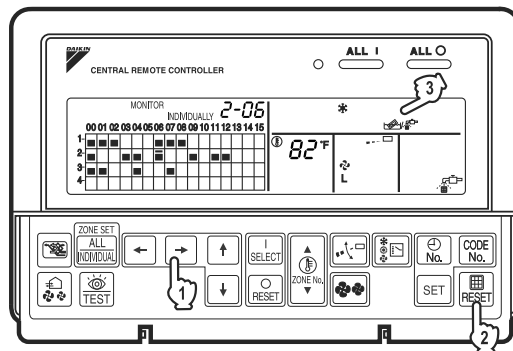

Fig. 16

13.10 <DCS301C71> Unified ON/OFF Controller (Installation)

Please read these "SAFETY CONSIDERATIONS" carefully before installing air conditioning equipment and be sure to install it correctly. After completing the installation, make sure that the unit operates properly during the start-up operation.
 Please instruct the customer on how to operate the unit and keep it maintained.
 Also, inform customers that they should store this installation manual along with the operation manual for future reference.
 This air conditioner comes under the term "appliances not accessible to the general public".

Meaning of warning, caution and note symbols.

⚠ WARNING..... Indication a potentially hazardous situation which, if not avoided, could result in death or serious injury.
⚠ CAUTION..... Indication a potentially hazardous situation which, if not avoided, may result in minor or moderate injury. It may also be used to alert against unsafe practices.
⚠ NOTE..... Indication situation that may result in equipment or property-damage-only accidents.

⚠ WARNING

Ask your dealer or qualified personnel to carry out installation work. Do not try to install the machine by yourself.
 Improper installation may result in water leakage, electric shocks or fire.

Perform installation work in accordance with this installation manual.
 Improper installation may result in water leakage, electric shocks or fire.

Be sure to use only the specified accessories and parts for installation work.
 Failure to use the specified parts may result in water leakage, electric shocks, fire or the unit falling.

Carry out the specified installation work after taking into account strong winds, typhoons or earthquakes.
 Improper installation work may result in the equipment falling and causing accidents.

Make sure that a separate power supply circuit is provided for this unit and that all electrical work is carried out by qualified personnel according to local laws and regulations and this installation manual.
 An insufficient power supply capacity or improper electrical construction may lead to electric shocks or fire.

Make sure that all wiring is secured, the specified wires are used, and no external forces act on the terminal connections or wires.
 Improper connections or installation may result in fire.

When wiring the power supply and connecting the remote controller wiring and transmission wiring, position the wires so that the electric parts box lid can be securely fastened.
 Improper positioning of the electric parts box lid may result in electric shocks, fire or the terminals overheating.

Before touching electrical parts, turn off the unit.

Ground the air conditioner. Do not connect the ground wire to gas or water pipes, lightning rod or a telephone ground wire.
 Incomplete grounding may result in electric shocks.

When installing or relocating the system, be sure to keep the refrigerant circuit free from substances other than the specified refrigerant (R410A), such as air.

Do not reconstruct or change the settings of the protection devices.
 If the pressure switch, thermal switch, or other protection device is shorted and operated forcibly, or parts other than those specified by Daikin are used, fire or explosion may result.

Do not touch the switch with wet fingers.
 Touching a switch with wet fingers can cause electric shock.

Install an leak circuit breaker, as required.
 If an leak circuit breaker is not installed, electric shock may result.

Do not install the air conditioner or the remote controller in the following locations:

- (a) where a mineral oil mist or an oil spray or vapor is produced, for example in a kitchen
 Plastic parts may deteriorate and fall off or result in water leakage.
- (b) where corrosive gas, such as sulfurous acid gas, is produced
 Corroding copper pipes or soldered parts may result in refrigerant leakage.
- (c) near machinery emitting electromagnetic waves
 Electromagnetic waves may disturb the operation of the control system and result in a malfunction of the equipment.
- (d) where flammable gases may leak, where there are carbon fiber or ignitable dust suspensions in the air, or where volatile flammables such as thinner or gasoline are handled.
 Operating the unit in such conditions may result in fire.

⚠ CAUTION

Be very careful about product transportation.

Safely dispose of the packing materials.
 Packing materials, such as nails and other metal or wooden parts, may cause stabs or other injuries.
 Tear apart and throw away plastic packaging bags so that children will not play with them. If children play with a plastic bag which was not torn apart, they face the risk of suffocation.

Do not turn off the power immediately after stopping operation.
 Always wait at least five minutes before turning off the power. Otherwise, water leakage and trouble may occur.

⚠ NOTE

Install the indoor and outdoor units, power supply wiring and connecting wires at least 3.5ft. away from televisions or radios in order to prevent image interference or noise.
 (Depending on the radio waves, a distance of 3.5ft. may not be sufficient enough to eliminate the noise.)

Remote controller (wireless kit) transmitting distance can result shorter than expected in rooms with electronic fluorescent lamps. (inverter or rapid start types)
 Install the indoor unit as far away from fluorescent lamps as possible.

This unit is a class A product.
 In a domestic environment this product may cause radio interference in which case the user may be required to take adequate measures.

Dismantling of the unit, treatment of the refrigerant, oil and eventual other parts, should be done in accordance with the relevant local and national regulations.

1 COMPONENTS

Check the following components are included in this optional accessory before installation.

Body

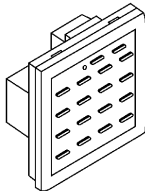

Installation screw (M4 x 16)	2
Operation manual	1
Installation manual	4
Installation table	4
Switch display sticker	1

When using this optional accessory an electric parts box of KJB212A is required. For installation, a steel electric parts box to be embedded is mandatory.

2 SYSTEM CONFIGURATION

This unified ON/OFF controller enables individual and unified operation/stop for a maximum of 16 groups of indoor units. With 2 to 8 unified ON/OFF controllers, individual and unified control is possible with up to a maximum 128 groups of indoor units.

- When using 1 unified ON/OFF controller

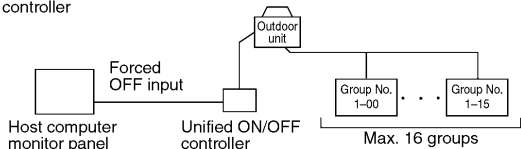

(This optional accessory can not be used in conjunction with wiring adapter for electrical appendices (optional accessory).)

- When using 2 to 8 unified ON/OFF controllers

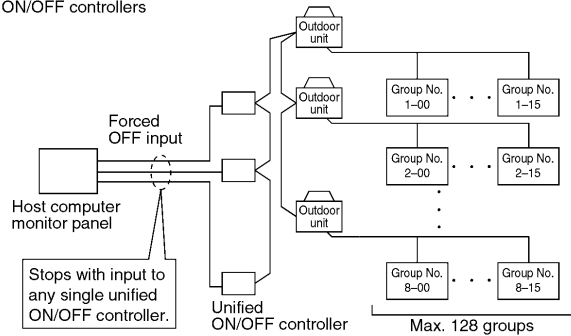

The groups of indoor units are as follows:

- 1 One indoor unit without remote controller

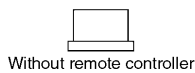

- 2 One indoor unit controlled by one or two remote controllers

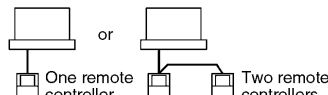

- 3 A maximum of 16 indoor units controlled in groups by one or two remote controllers

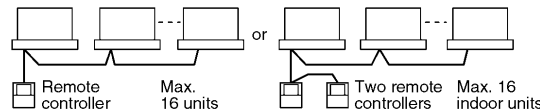

3 INSTALLATION

- 1 Open the upper part of remote controller. Insert a ⊖ screwdriver (2 locations) into the recess between the upper part and the lower part of remote controller and twist the screwdriver lightly.

PC board is attached with both the upper and lower part of remote controller. Do not damage the board with the screwdriver.

- 2 Open the upper part of remote controller and install the electric parts box (part to be procured in the field) with the attached installation screws (M4 x 16).

NOTE) Suitable length of the electric wire is about 160mm from the inlet of the electric parts box. If it is difficult to contain a long wiring, strip the sheathed part of the wiring.

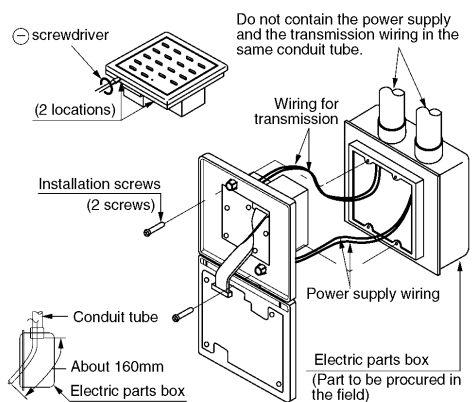

4 INITIAL SETTING

Setting ① through ③ are initialized when power is turned ON, therefore complete settings BEFORE activating the power.

- Connector for setting master controller (X1A) (Provided with connector at factory set)
 - When using 1 unified ON/OFF controller, do not disconnect the connector for setting master controller. (Use the unit with the connector in the state in which it was delivered.)
 - When using multiple unified ON/OFF controllers, or using the unified ON/OFF controller in conjunction with other optional controllers for centralized control, makes settings as indicated in the right table.

Pattern of connection of optional controllers for centralized control			Connector for setting master controller (X1A) Settings		
Unified ON/OFF controller	Central remote controller	Schedule timer	Unified ON/OFF controller	Central remote controller	Schedule timer
1 to 16	1 to 4		Set one to "Used" and all the rest to "Not used".	(Note)	
		1	Set all to "Not used".		"Not used"
	1 to 4	1	Set one to "Used" and all the rest to "Not used".	(Note)	"Not used"

(Note) For instructions on how to set the connector for setting master controller on the central remote controller, see the installation manual provided with the central remote controller.

- Switch for setting each address (DS1)
These switches are used to set group control address.
Groups Nos. 1-00 through 1-15 are grouped in the same control group when the unit is shipped from the factory.

Each Address	1-00 - 1-15	2-00 - 2-15	3-00 - 3-15	4-00 - 4-15	5-00 - 5-15	6-00 - 6-15	7-00 - 7-15	8-00 - 8-15
DS1 setting								

NOTE) ■ indicates the position of switches.

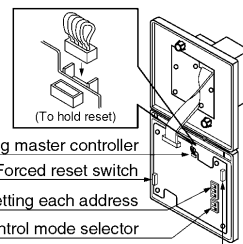

After setting, attach the number seal applicable to respective control range of the attached switch display sticker, as shown in the diagram below.

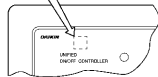

(Example)
In the case of 1-00 to 1-15, attach ①.

- MAIN/SUB changeover switch setting
With two unified ON/OFF controllers, centralized control (indoor units) is possible from different locations. In this kind of set-up, it is necessary to set the MAIN/SUB changeover switch. One of the two unified ON/OFF controllers (1)-(2) is set to "MAIN" while the other is set to "SUB".

- Setting of the sequential operation function

The unified ON/OFF controller is equipped with a sequential operation function that sequentially turns indoor units on in 2-second intervals during unified operation. (Sequential operation is factory set to "ON.")
To switch sequential operation ON or OFF, set as follows.

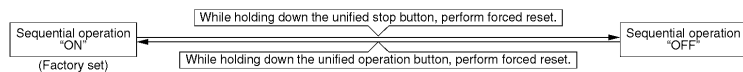

NOTE: The sequential operation function is designed to reduce the load on the power supply equipment, but does not guarantee that compressors will not be started simultaneously. You cannot therefore count on a capacity reduction effect by power supply equipment breaker selection.

- Control mode selector (DS2)
The following four patterns of control mode can be set.

Control mode	Individual	Centralized	Timer operation possible by remote controller	ON/OFF control impossible by remote controller
Content	Operation/stop is controlled by both unified ON/OFF controller and remote controller.	After operated by unified ON/OFF controller, operation/stop is freely controlled by remote controller until stopped by unified ON/OFF controller.	When used in conjunction with schedule timer, operation/stop is controlled freely by remote controller during the set time but operation is not available when schedule timer is ON.	Operation/stop is controlled by unified ON/OFF controller only. (This unit can not be operated/stopped by remote controller.)
DS2 setting	(Factory set)			

- NOTES) ■ indicates the position of switches.
Set control mode before turning power supply ON.
When used in conjunction with central remote controller, the control modes of the central remote controller has the priority.

- Forced reset switch (SS1)
When changing the setting of the connector for setting master controller, etc., you can reset simply by setting it to the reset side once and returning to the normal side, without turning the power OFF. (For normal operation, set the switch to the normal side.)

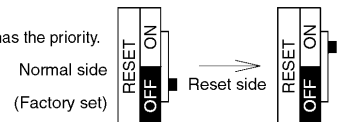

5 ELECTRIC WIRING

GENERAL INSTRUCTIONS

- All wiring, components and materials to be procured on the site must comply with the applicable local and national codes.
- Use copper conductors only.
- All field wiring and components must be provided by licensed electrician.
- Unit shall be grounded in compliance with the applicable local and national codes.
- Fit the power supply wiring with a fuse and a switch.
- After wiring work, check power to the equipment shuts OFF when switch is shut OFF.

WIRING OUTLINE

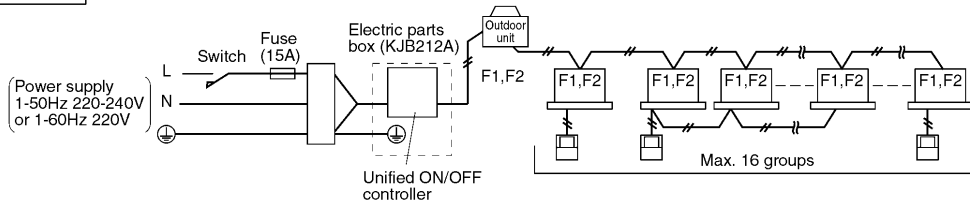

Wiring specification

	Type	Size
Power supply wiring	H05VV-U3G	(NOTE 1)
Transmission wiring	Sheathed wire (2 wire) (NOTE 2)	0.75 - 1.25mm ²

- NOTES
1. The size of power supply wiring must comply with the applicable national and local codes.
 2. Allowable length of transmission wiring is as follows.
Max. 1000m (Total wiring length: 2000m)

Connect the wiring between indoor and outdoor units, indoor/outdoor units and power supply, and indoor units and remote controllers. For details, refer to the installation manuals of indoor and outdoor units.

WIRING TO THE INDOOR UNIT AND OUTDOOR UNIT

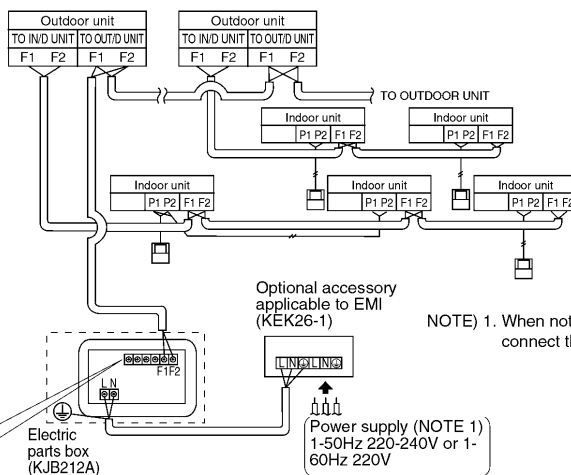

- NOTE 1. When not using the optional accessory applicable to EMI (KEK26-1), connect the power supply wiring directly to the unified ON/OFF controller.

CONTROL TERMINAL STRIP

*1 For connecting indoor unit (F1, F2)

*2 Forced OFF input (T1, T2)

While the forced OFF input (no voltage contactor, for micro current) is ON (energized), all the connected indoor units are stopped and can not be operated.

Use only contactors which guarantee the minimum applicable load ≧ 16V, 10mA.

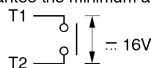

NOTE) Use instantaneous contactor of over 200msec. energizing time, when necessary.

*3 For schedule timer (D1, D2)

Power can be supplied to the schedule timer (DST301B51*61 optional accessory). For details, refer to the installation manual of the schedule timer.

Wire *2 and *3 only when necessary.

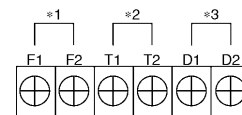







(NOTE)

Do not connect the power supply wiring (220 to 240V) to the control terminal strip. If connected by mistake, it may damage or burn electrical parts of optional controllers for centralized control and indoor unit. It may result in serious danger. Be sure to check wirings before turning the power ON.

6 SETTING GROUP NO. FOR CENTRALIZED CONTROL

Set the group number of each group of the indoor unit from the remote controller. (In case of no remote controller, also connect the remote controller and set the group No. Then, remove the remote controller.)

- 1 Turn ON the power of the indoor unit and unified ON/OFF controller. (Unless the power is ON, no setting can be made.)
Check that the installation and electrical wiring are correct before turning the power supply ON.
When the power supply is turned ON, all LCD appear once and the unit may not accept the operation for about one minute with the display of "  " flashing (an interval of ON, ON, and OFF).
- 2 While in the normal mode, hold down the "  " button for a minimum of 4 seconds.
The remote controller will enter the FIELD SET MODE.
- 3 Select the MODE No. "  " with the "  " button.
- 4 Use the "  " button to select the group No. for each group.
(Group numbers increase in the order of 1-00, 1-01, ... 1-15, 2-00, ... 8-15.)
- 5 Press "  " to set the selected group No.
- 6 Press "  " to return to the NORMAL MODE.

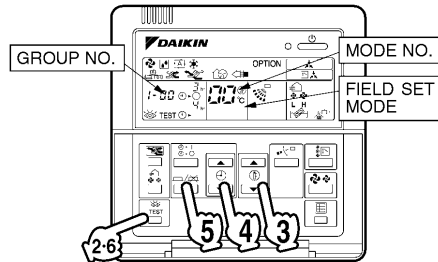

- NOTES)
- For simplified remote controller, see the installation table.
 - For setting group No. of HRV and wiring adaptor for other air conditioners, etc., refer to the instruction manual attached.

NOTICE Enter the group No. and installation place of the indoor unit into the attached installation table.
Be sure to keep the installation table with the operation manual for maintenance.

7 CONFIRMING OPERATION

Before starting test operation, supply power to the indoor units, outdoor units, and unified ON/OFF controller and press the ON/OFF BUTTON.

If the operation lamp flashes, it indicates a malfunction in the indoor unit of the applicable group.



If the display of "  " flashes, it indicates a malfunction in the optional controllers for centralized control. Check for such malfunctions.

- NOTES**
- For test operation of indoor and outdoor units, refer to the installation manual attached with the outdoor unit.
 - After turning the power supply ON, if the unit does not accept operation for two minutes or more with the display of "  " flashing, check the following points.
 - Check that setting of the connector for setting master controller is correct.
 - Check that the group No. for centralized control has been set.

13.11 <DCS301C71> Unified ON/OFF Controller (Operation)

Please read these "SAFETY CONSIDERATIONS" carefully before installing air conditioning equipment and be sure to install it correctly. After completing the installation, make sure that the unit operates properly during the start-up operation.
Please instruct the customer on how to operate the unit and keep it maintained.
Also, inform customers that they should store this installation manual along with the operation manual for future reference.
This air conditioner comes under the term "appliances not accessible to the general public"

Meaning of warning, caution and note symbols.

-  **WARNING** Indication a potentially hazardous situation which, if not avoided, could result in death or serious injury.
 **CAUTION** Indication a potentially hazardous situation which, if not avoided, may result in minor or moderate injury. It may also be used to alert against unsafe practices.
 **NOTE** Indication situation that may result in equipment or property-damage-only accidents.

Keep these warning sheets handy so that you can refer to them if needed.

Also, if this equipment is transferred to a new user, make sure to hand over this operation manual to the new user.

WARNING

In order to avoid electric shock, fire or injury, or if you detect any abnormality such as smell of fire, turn off power and call your dealer for instructions.

Ask your dealer for installation of the air conditioner.

Incomplete installation performed by yourself may result in a water leakage, electric shock, and fire.

Ask your dealer for improvement, repair, and maintenance.

Incomplete improvement, repair, and maintenance may result in a water leakage, electric shock, and fire.

**Improper installation or attachment of equipment or accessories could result in electric shock, short-circuit, leaks, fire or other damage to the equipment.
Be sure only to use accessories made by Daikin which are specifically designed for use with the equipment and have them installed by a professional.**

Ask your dealer to move and reinstall the air conditioner or the remote controller.

Incomplete installation may result in a water leakage, electric shock, and fire.

Never let the indoor unit or the remote controller get wet.

It may cause an electric shock or a fire.

Never use flammable spray such as hair spray, lacquer or paint near the unit.

It may cause a fire.

Never replace a fuse with that of wrong ampere ratings or other wires when a fuse blows out.

Use of wire or copper wire may cause the unit to break down or cause a fire.

Never inspect or service the unit by yourself.

Ask a qualified service person to perform this work.

Cut off all electric waves before maintenance.

Do not wash the air conditioner or the remote controller with excessive water.

Electric shock or fire may result.

Do not install the air conditioner or the remote controller at any place where flammable gas may leak out.

If the gas leaks out and stays around the air conditioner, a fire may break out.

Do not touch the switch with wet fingers.

Touching a switch with wet fingers can cause electric shock.

CAUTION

After a long use, check the unit stand and fitting for damage.

If they are left in a damaged condition, the unit may fall and result in injury.

Do not allow a child to mount on the unit or avoid placing any object on it.

Falling or tumbling may result in injury.

Do not let children play on and around the unit.

If they touch the unit carelessly, it may result in injury.

Do not place a flower vase and anything containing water.

Water may enter the unit, causing an electric shock or fire.

Never touch the internal parts of the controller.

Do not remove the front panel. Some parts inside are dangerous to touch, and a machine trouble may happen.

For checking and adjusting the internal parts, contact your dealer.

Avoid placing the controller in a spot splashed with water.

Water coming inside the machine may cause an electric leak or may damage the internal electronic parts.

Do not operate the air conditioner when using a room fumigation - type insecticide.

Failure to observe could cause the chemicals to become deposited in the unit, which could endanger the health of those who are hypersensitive to chemicals.

Safely dispose of the packing materials.

Packing materials, such as nails and other metal or wooden parts, may cause stabs or other injuries.

Tear apart and throw away plastic packaging bags so that children will not play with them. If children play with a plastic bag which was not torn apart, they face the risk of suffocation.

Do not turn off the power immediately after stopping operation.

Always wait at least five minutes before turning off the power. Otherwise, water leakage and trouble may occur.

The appliance is not intended for use by young children or infirm persons without supervision.

The remote controller should be installed in such away that children cannot play with it.

NOTE

Never press the button of the remote controller with a hard, pointed object.

The remote controller may be damaged.

Never pull or twist the electric wire of the remote controller.

It may cause the unit to malfunction.

Do not place the controller exposed to direct sunlight.

The LCD display may get discolored, failing to display the data.

Do not wipe the controller operation panel with benzine, thinner, chemical dustcloth, etc.

The panel may get discolored or the coating peeled off. If it is heavily dirty, soak a cloth in water-diluted neutral detergent, squeeze it well and wipe the panel clean. And wipe it with another dry cloth.

Dismantling of the unit, treatment of the refrigerant, oil and eventual other parts, should be done in accordance with the relevant local and national regulations.

1 NAMES AND FUNCTIONS

"UNDER HOST COMPUTER INTEGRATED CONTROL" LAMP
When this lamp turns on, no other operations are possible.

GROUP NO.

ROOM NAME INDICATION PLATE
Refer to the "2. PUTTING ROOM NAME INDICATION STICKER"

UNIFIED OPERATION/STOP BUTTON
Starts/stops all indoor units.

OPERATION LAMP
Turns on during operation of each group and flashes during malfunction stop.

INDIVIDUAL OPERATION/STOP BUTTON
Starts/stops each indoor unit group individually.

«NOTE»

- When using unified ON/OFF controller with other optional controllers for centralized control, "OPERATION LAMP" of the equipment which is not operated may turn on or off after several minutes. This state occurs due to signal communications and is not a failure.
- Do not open the upper part of remote controller except when rewriting the indication sticker or selecting control modes.

2 PUTTING ROOM NAME INDICATION STICKER

① Open the upper part of remote controller. Insert a (-) screwdriver into the recess between the upper and lower part of remote controller (at 2 locations) and twist the screwdriver lightly.

PC board is attached both the upper and lower part of remote controller. Do not damage the board with the screwdriver.

② Pull out the room name indication plate. Insert the point of a mechanical pencil etc, into the hole of the indication sticker to pull it out.

③ Put the attached indication sticker on the room name indication plate.

In case of serial type Indication sticker: Put the sticker aligning the lines of the sticker with those of the plate.

In case of individual type Indication sticker: Put the sticker on the center of the frame. Write the room name in the frame of the sticker with a ball point pen or a felt-tip pen (oil-base).

④ Reinstall the plate as it were, with checking the correct direction.

⑤ Close the upper part of remote controller.

3 SELECTING CONTROL MODES

The following four patterns of control mode can be set.

Control mode	Individual	Centralized	Timer operation possible by remote controller	ON/OFF control impossible by remote controller
Content	Operation/stop is controlled by both unified ON/OFF controller and remote controller.	After operated by unified ON/OFF controller, operation/stop is freely controlled by remote controller until stopped by unified ON/OFF controller.	When used in conjunction with schedule timer, operation/stop is controlled freely by remote controller during the set time but operation is not available when schedule timer is ON.	Operation/stop is controlled by unified ON/OFF controller only. Indoor units can not be operated/ stopped by remote controller.
DS2 setting				

NOTE:

- indicates the position of switches.
- Set control modes before turning power supply on.
- When used in conjunction with central remote controller, the control modes of the central remote controller has the priority.

4 DISPLAY OF MALFUNCTION

Flashing of lamps indicates malfunctions. Contact your Daikin dealer. When turning power supply on, all lamps may light and UNDER HOST COMPUTER INTEGRATED CONTROL lamp may flash and not accept the operation for about on minute. These conditions are not malfunctions.

States of lamps	Contents of malfunctions
Flashing of operation lamp	Indicates malfunctions in the indoor unit in the group where the operation lamp is flashing.
Flashing of UNDER HOST COMPUTER INTEGRATED CONTROL lamp	Indicates malfunctions in optional controllers for centralized control.

13.12 <DST301BA61> Schedule Timer Controller (Installation)

Please read these "SAFETY CONSIDERATIONS" carefully before installing air conditioning equipment and be sure to install it correctly. After completing the installation, make sure that the unit operates properly during the start-up operation. Please instruct the customer on how to operate the unit and keep it maintained. Also, inform customers that they should store this installation manual along with the operation manual for future reference. This air conditioner comes under the term "appliances not accessible to the general public".

Meaning of warning, caution and note symbols.

- ⚠ **WARNING**Indication a potentially hazardous situation which, if not avoided, could result in death or serious injury.
- ⚠ **CAUTION**Indication a potentially hazardous situation which, if not avoided, may result in minor or moderate injury. It may also be used to alert against unsafe practices.
- ⚠ **NOTE** Indication situation that may result in equipment or property-damage-only accidents.

⚠ **WARNING**

Ask your dealer or qualified personnel to carry out installation work. Do not try to install the machine by yourself.
Improper installation may result in water leakage, electric shocks or fire.

Perform installation work in accordance with this installation manual.
Improper installation may result in water leakage, electric shocks or fire.

Be sure to use only the specified accessories and parts for installation work.
Failure to use the specified parts may result in water leakage, electric shocks, fire or the unit falling.

Carry out the specified installation work after taking into account strong winds, typhoons or earthquakes.
Improper installation work may result in the equipment falling and causing accidents.

Make sure that a separate power supply circuit is provided for this unit and that all electrical work is carried out by qualified personnel according to local laws and regulations and this installation manual.
An insufficient power supply capacity or improper electrical construction may lead to electric shocks or fire.

Make sure that all wiring is secured, the specified wires and used, and no external forces act on the terminal connections or wires.
Improper connections or installation may result in fire.

When wiring the power supply and connecting the remote controller wiring and transmission wiring, position the wires so that the electric parts box lid can be securely fastened.
Improper positioning of the electric parts box lid may result in electric shocks, fire or the terminals overheating.

Before touching electrical parts, turn off the unit.

Ground the air conditioner. Do not connect the ground wire to gas or water pipes, lightning rod or a telephone ground wire.
Incomplete grounding may result in electric shocks.

When installing or relocating the system, be sure to keep the refrigerant circuit free from substances other than the specified refrigerant (R410A), such as air.

Do not reconstruct or change the settings of the protection devices.
If the pressure switch, thermal switch, or other protection device is shorted and operated forcibly, or parts other than those specified by Daikin are used, fire or explosion may result.

Do not touch the switch with wet fingers.
Touching a switch with wet fingers can cause electric shock.

Install an earth leak circuit breaker, as required.
If an earth leak circuit breaker is not installed, electric shock may result.

- Do not install the air conditioner or the remote controller in the following locations:**
- (a) where a mineral oil mist or an oil spray or vapor is produced, for example in a kitchen
Plastic parts may deteriorate and fall off or result in water leakage.
 - (b) where corrosive gas, such as sulfurous acid gas, is produced
Corroding copper pipes or soldered parts may result in refrigerant leakage.
 - (c) near machinery emitting electromagnetic waves
Electromagnetic waves may disturb the operation of the control system and result in a malfunction of the equipment.
 - (d) where flammable gases may leak, where there are carbon fiber or ignitable dust suspensions in the air, or where volatile flammables such as thinner or gasoline are handled.
Operating the unit in such conditions may result in fire.

CISPR 22 Class A Warning.
This is a class A product. In a domestic environment this product may cause radio interference in which case the user may be required to take adequate measures.

⚠ CAUTION

Be very careful about product transportation.

Safely dispose of the packing materials.

Packing materials, such as nails and other metal or wooden parts, may cause stabs or other injuries. Tear apart and throw away plastic packaging bags so that children will not play with them. If children play with a plastic bag which was not torn apart, they face the risk of suffocation.

Do not turn off the power immediately after stopping operation.

Always wait at least five minutes before turning off the power. Otherwise, water leakage and trouble may occur.

⚠ NOTE

Install the indoor and outdoor units, power supply wiring and connecting wires at least 3.5ft. away from televisions or radios in order to prevent image interference or noise.

(Depending on the radio waves, a distance of 3.5ft. may not be sufficient enough to eliminate the noise.)

Remote controller (wireless kit) transmitting distance can result shorter than expected in rooms with electronic fluorescent lamps. (inverter or rapid start types)

Install the indoor unit as far away from fluorescent lamps as possible.

This unit is a class A product.

In a domestic environment this product may cause radio interference in which case the user may be required to take adequate measures.

Dismantling of the unit, treatment of the refrigerant, oil and eventual other parts, should be done in accordance with the relevant local and national regulations.

1 ACCESSORIES

Check the following accessories are included in the kit before installation.

Body	1	Installation screws (M4 × 16)	2
Operation manual	1	Attached electric wire (for individual use)	1
Installation manual*	4	Crimp style terminal (for individual use)	2

For Installation, a electrical box to be embedded is necessary (part to be procured in the field/with covers).
 * DST301BA61 includes only one installation manual.

2 INSTALLATION AND INITIAL SETTING

1. Remove the upper part of the remote controller.

- Insert a (-) screwdriver (2 locations) into the recess between the upper part and the lower part of the remote controller and twist the screwdriver lightly.

(The PC board is attached with the upper part of the remote controller. Do not damage electric parts with a screwdriver, etc.)

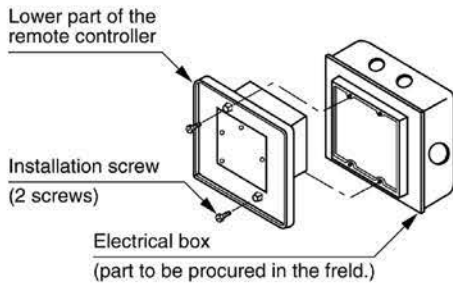
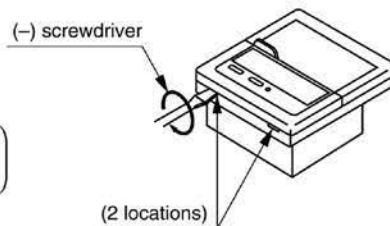

- Attach the lower part to the electrical box (part to be procured in the field) with the provided installation screws.

(Select a flat face as a installation place. Do not tighten the installation screws excessively not to damage the lower part of the remote controller.)

For part to be procured in the field electrical box, use KJB212AA (optional accessory).

2. Initial setting

- ① Setting connector for individual use (X1A) (Factory set : OFF) (Set for individual use only)
 - For individual use of schedule timer
Insert the connector attached with the body case on the PC board.
 - For combined use with other optional controllers for centralized control
Do not change the factory setting.

- ② Control mode selector (SS2) (Set for individual use only)
By changing the switch, setting mode of individual and centralized operation is available.

Note) When used with other optional controllers, control mode of central remote controller and unified ON/OFF controller have the priority.

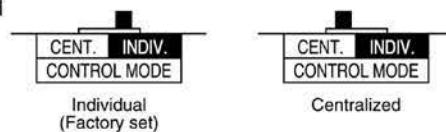

- ③ Setting of the sequential operation function
The schedule timer is equipped with a sequential operation function that sequentially turns indoor units on in 2-second intervals during unified operation. (Sequential operation is factory set to "ON.")
To switch sequential operation ON or OFF, set as follows.

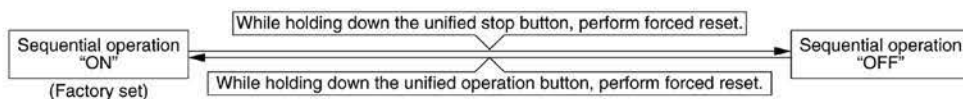

Note) The sequential operation function is designed to reduce the load on the power supply equipment, but does not guarantee that compressors will not be started simultaneously. You cannot therefore count on a capacity reduction effect by power supply equipment breaker selection.

- ④ **Forced reset switch (SS1)**
 When changing the setting of the connector for individual use, etc., the switch can be reset simply by setting it to the reset side once and returning to the normal side. This procedure enables to reset without turning off the power. (Set the normal side at normal operation.)

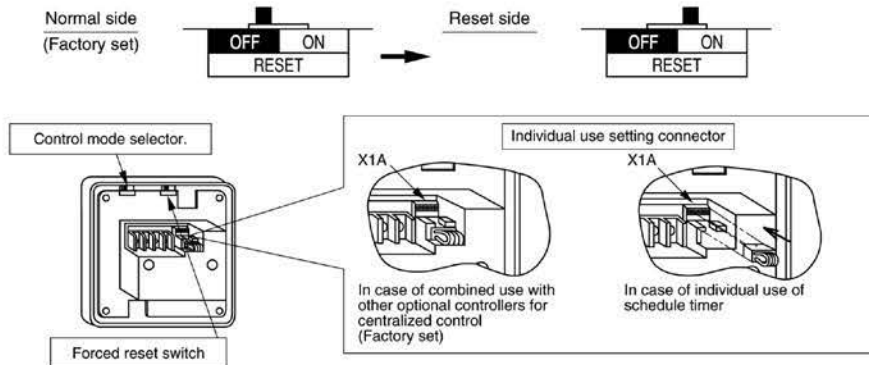

- ⑤ **Setting for special function**
 When you want to have a programmed operation of a part of indoor units by using only schedule timer, cut off JP1 and supply the power again. You can have a programmed operation of the indoor units set the address for central control by local remote controller.

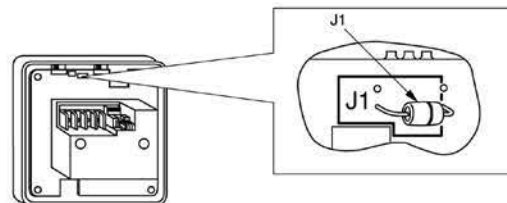

3. Transmission wiring

- **In case of individual use of schedule timer**
 Connect terminals of the schedule timer (F1, F2) with terminals of the indoor unit (F1, F2). Connect terminals of the schedule timer (D1, D2) and the connector on the indoor unit PC board, using the attached electric wire and crimp style terminals. Prevent the connection part of crimp style terminal from getting out of the electric parts box of indoor unit.
- **In case of combined use with other optional controllers for centralized control**
 Connect terminals of the schedule timer (F1, F2, D1, D2) and the terminals of the central remote controller (or unified ON/OFF controller).

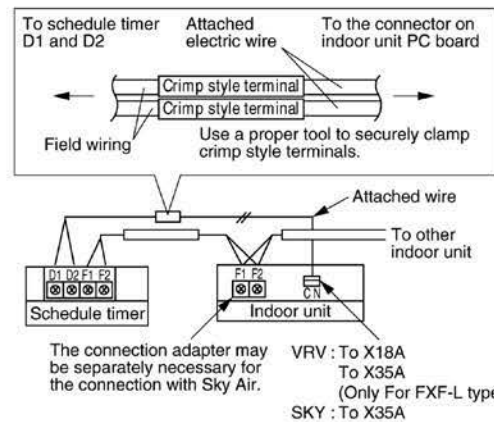

Wiring specifications

	F1, F2	D1, D2
Wiring	Sheathed wire (2-wire)	Sheathed wire (2-wire)
Gauge	0.75 ~ 1.25mm ²	0.75 ~ 1.25mm ²
Length	Max. 1000m	Max. 150m

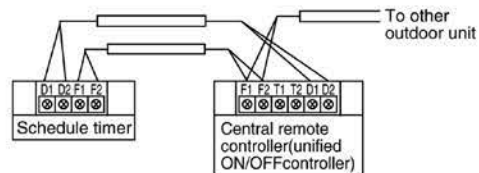

NOTES:

1. Electrical box and transmission wiring are not attached.
2. Do not touch the PC board with your hand.
3. Keep transmission wiring at least 50 mm away from power supply wiring to avoid malfunctions.

4. **Install the upper part of the remote controller as before.**

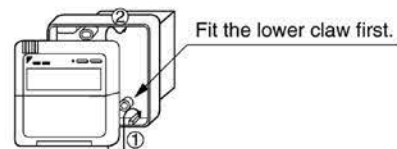

3 SETTING GROUP NO. FOR CENTRALIZED CONTROL

- Set the group number of each group of the indoor unit from the remote controller. (In case of no remote controller, also connect the remote controller and set the group No. Then, remove the remote controller.)
- (1) Turn ON the power of the indoor unit and SCHEDULE TIMER.
(Unless the power is ON, no setting can be made.)
Check that the installation and electrical wiring are correct before turning the power supply ON.
(When the power supply is turned ON, all LCD appear once and the unit may not accept the operation for about one minute with the display of "SS".)
 - (2) While in the normal mode, hold down the "TEST" button for a minimum of 4 seconds.
The remote controller will enter the FIELD SET MODE.
 - (3) Select the MODE No. "00" with the "MODE NO." button.
 - (4) Use the "GROUP NO." button to select the group No. for each group.
(Group numbers increase in the order of 1-00, 1-01, ... 1-15, 2-00, ... 8-15.)
 - (5) Press "OK" to set the selected group No.
 - (6) Press "TEST" to return to the NORMAL MODE.

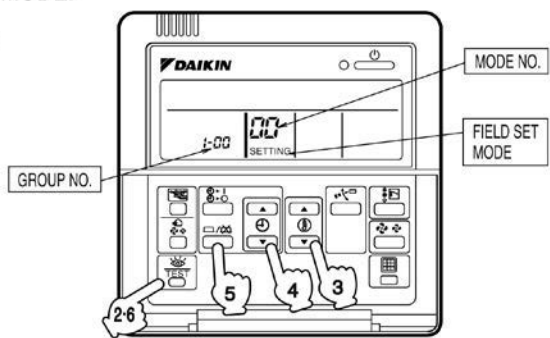

NOTES)

- In case of individual use of schedule timer
Group number setting is not necessary. It is automatically set when turning power supply ON.
- See the instruction manuals which came with the Ventiair and adapters (i.e., multi-purpose adapters) for details on their Group No. settings.

NOTICE Be sure to keep the operation manual for maintenance.

4 TEST OPERATION

Refer to the installation manual attached to the outdoor unit.

In case the schedule timer is used individually and the wiring is changed after the system has been operated, reset the power after energizing for more than five minutes.
It may not be possible to control the unit from the schedule timer.

13.13 <DST301BA61> Schedule Timer Controller (Operation)

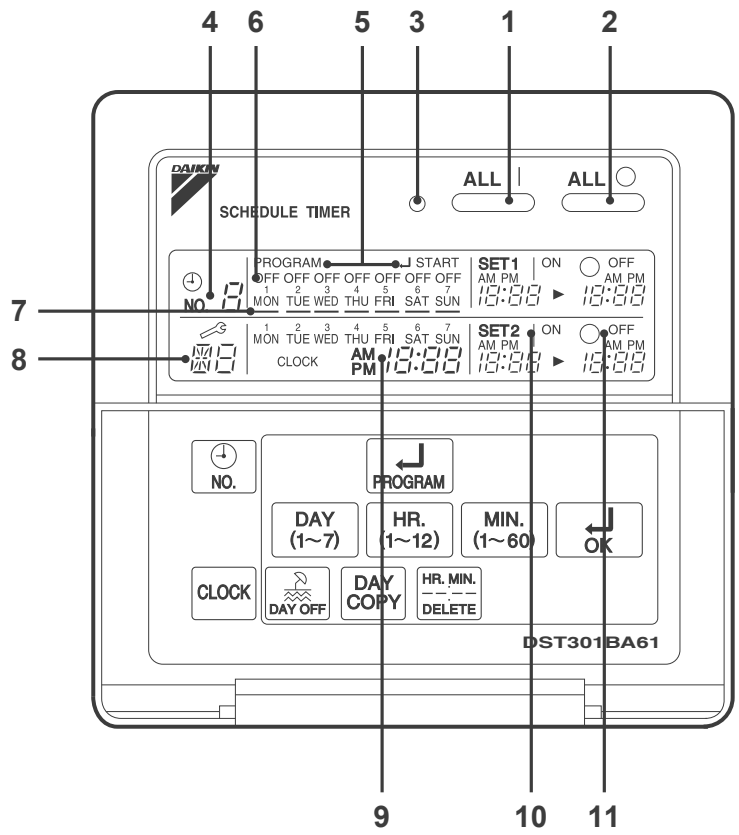

1

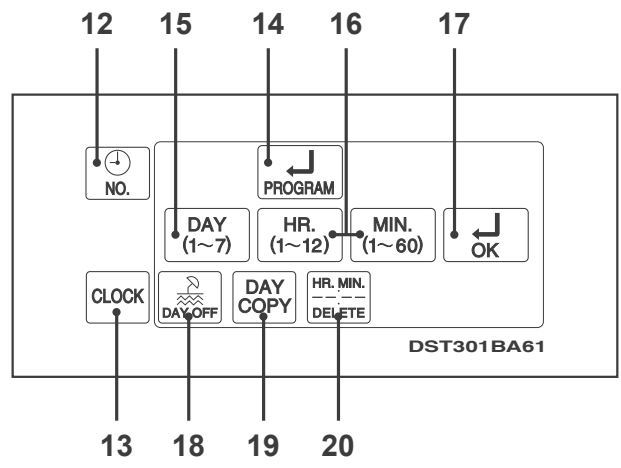

2

[1]

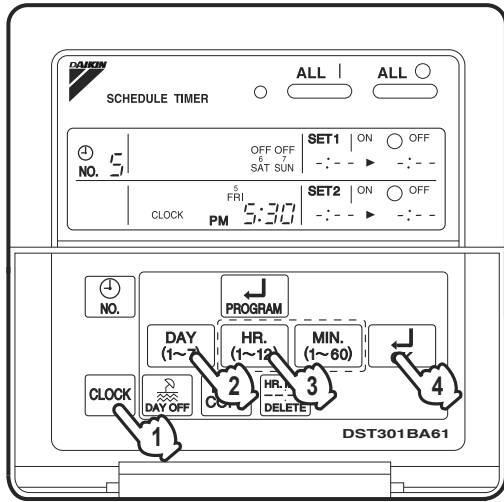

3

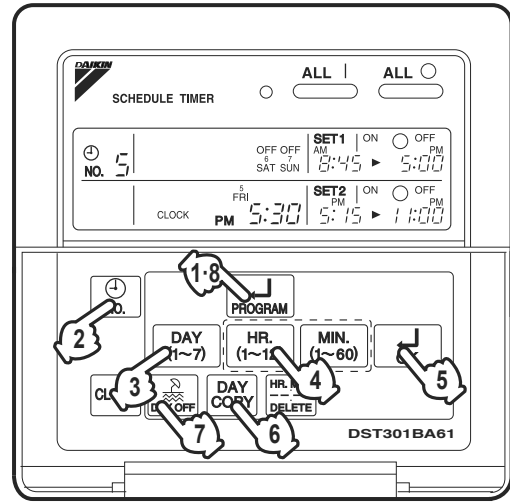

4

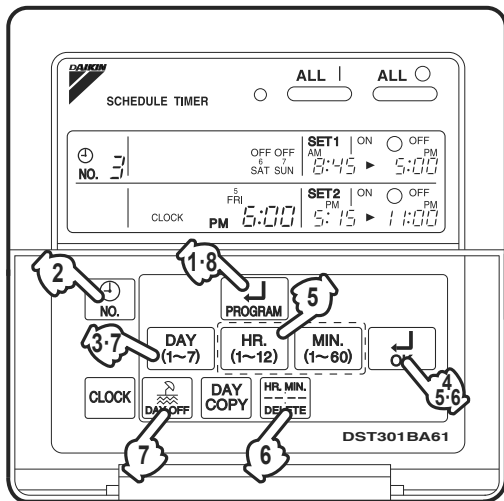

5

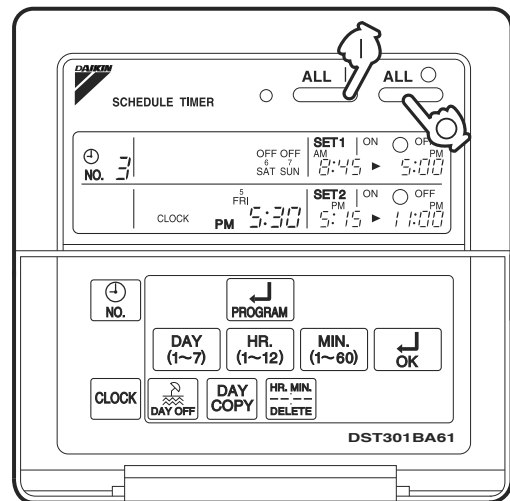

6

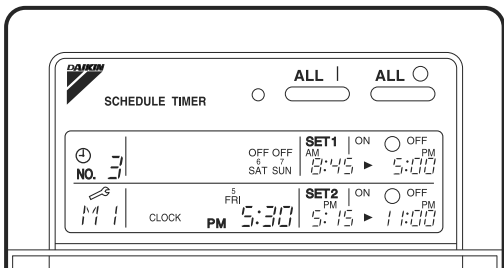

7

[2]

SAFETY CONSIDERATIONS

Please read these " SAFETY CONSIDERATIONS " carefully before installing air conditioning equipment and be sure to install it correctly. After completing the installation, make sure that the unit operates properly during the start-up operation.

Please instruct the customer on how to operate the unit and keep it maintained.

Also, inform customers that they should store this installation manual along with the operation manual for future reference.

This air conditioner comes under the term " appliances not accessible to the general public ".

Meaning of warning, caution and note symbols.

 **WARNING** Indicates a potentially hazardous situation which, if not avoided, could result in death or serious injury.

 **CAUTION** Indicates a potentially hazardous situation which, if not avoided, may result in minor or moderate injury. It may also be used to alert against unsafe practices.

 **NOTE** Indicates situation that may result in equipment or property-damage-only accidents.

Keep these warning sheets handy so that you can refer to them if needed.

Also, if this equipment is transferred to a new user, make sure to hand over this operation manual to the new user.

—  **WARNING** —

In order to avoid electric shock, fire or injury, or if you detect any abnormality such as smell of fire, turn off power and call your dealer for instructions.

Ask your dealer for installation of the air conditioner.

Incomplete installation performed by yourself may result in a water leakage, electric shock, and fire.

Ask your dealer for improvement, repair, and maintenance.

Incomplete improvement, repair, and maintenance may result in a water leakage, electric shock, and fire.

Improper installation or attachment of equipment or accessories could result in electric shock, short-circuit, leaks, fire or other damage to the equipment. Be sure only to use accessories made by Daikin which are specifically designed for use with the equipment and have them installed by a professional.

Ask your dealer to move and reinstall the air conditioner or the remote controller.

Incomplete installation may result in a water leakage, electric shock, and fire.

Never let the indoor unit or the remote controller get wet.

It may cause an electric shock or a fire.

Never use flammable spray such as hair spray, lacquer or paint near the unit.

It may cause a fire.

Never replace a fuse with that of wrong ampere ratings or other wires when a fuse blows out.

Use of wire or copper wire may cause the unit to break down or cause a fire.

Never inspect or service the unit by yourself.

Ask a qualified service person to perform this work.

Cut off all electric waves before maintenance.

Do not wash the air conditioner or the remote controller with excessive water.

Electric shock or fire may result.

Do not install the air conditioner or the remote controller at any place where flammable gas may leak out.

If the gas leaks out and stays around the air conditioner, a fire may break out.

Do not touch the switch with wet fingers.

Touching a switch with wet fingers can cause electric shock.

CISPR 22 Class A Warning:

This is a class A product. In a domestic environment this product may cause radio interference in which case the user may be required to take adequate measures.

⚠ CAUTION

After a long use, check the unit stand and fitting for damage.

If they are left in a damaged condition, the unit may fall and result in injury.

Do not allow a child to mount on the unit or avoid placing any object on it.

Falling or tumbling may result in injury.

Do not let children play on and around the unit.

If they touch the unit carelessly, it may result in injury.

Do not place a flower vase and anything containing water.

Water may enter the unit, causing an electric shock or fire.

Never touch the internal parts of the controller.

Do not remove the front panel. Some parts inside are dangerous to touch, and a machine trouble may happen.

For checking and adjusting the internal parts, contact your dealer.

Avoid placing the controller in a spot splashed with water.

Water coming inside the machine may cause an electric leak or may damage the internal electronic parts.

Do not operate the air conditioner when using a room fumigation - type insecticide.

Failure to observe could cause the chemicals to become deposited in the unit, which could endanger the health of those who are hypersensitive to chemicals.

Safely dispose of the packing materials.

Packing materials, such as nails and other metal or wooden parts, may cause stabs or other injuries.

Tear apart and throw away plastic packaging bags so that children will not play with them. If children play with a plastic bag which was not torn apart, they face the risk of suffocation.

Do not turn off the power immediately after stopping operation.

Always wait at least five minutes before turning off the power. Otherwise, water leakage and trouble may occur.

The appliance is not intended for use by young children or infirm persons without supervision.

The remote controller should be installed in such away that children cannot play with it.

⚠ NOTE

Never press the button of the remote controller with a hard, pointed object.

The remote controller may be damaged.

Never pull or twist the electric wire of the remote controller.

It may cause the unit to malfunction.

Do not place the controller exposed to direct sunlight.

The LCD display may get discolored, failing to display the data.

Do not wipe the controller operation panel with benzine, thinner, chemical dustcloth, etc.

The panel may get discolored or the coating peeled off. If it is heavily dirty, soak a cloth in water-diluted neutral detergent, squeeze it well and wipe the panel clean. And wipe it with another dry cloth.

Dismantling of the unit, treatment of the refrigerant, oil and eventual other parts, should be done in accordance with the relevant local and national regulations.

CONTENTS

SAFETY CONSIDERATIONS.....1	Change and cancellation of no. of programmed time.....7
FEATURES AND FUNCTIONS.....3	Manual operation.....9
NAMES AND FUNCTIONS OF OPERATING SECTION.....4	Operation control code.....9
OPERATION.....5	Error diagnosing function.....9
Setting present time.....5	QUESTION AND ANSWER.....10
Setting no. of programmed time.....6	SPECIFICATIONS.....12
	Specifications.....12
	Outline drawings.....12

FEATURES AND FUNCTIONS

■ **Operation controlled by programmed time**
 Operating time and stopping time can be set to the minute by each day of the week. The operating and stopping patterns can also be set in schedule according to the time slot given twice a day in tune with the uses.



See page 5—9.



■ **Unified Operation/Stop**
 By using this schedule timer, the unified operation/stop of the indoor unit can be executed manually regardless of the No. of programmed time in operation.







See page 9.

- **When used in conjunction with central remote controller (Optional Accessory)**
 The operation controlled by programmed time can be set for up to eight different patterns (timer No. 1 – 8). Each schedule pattern can be also selected.

NAMES AND FUNCTIONS OF OPERATING SECTION (Fig. 1, 2)

1	UNIFIED OPERATION BUT-TON “ ALL ”	Press this button to perform the unified operation regardless of the No. of programmed time.	9	DISPLAY “ ¹ MON ² TUE ³ WED ⁴ THU ⁵ FRI ⁶ SAT ⁷ SUN CLOCK AM PM 10:00 ” (PRESENT TIME)	Displays the present day of the week and time.
	UNIFIED STOP BUTTON “ ALL ○ ”			Press this button to perform the unified stop regardless of the No. of programmed time.	
3	OPERATION LAMP (RED)	The light turns on during the operation of the indoor unit.	11	DISPLAY “ ○ OFF AM PM 10:00 ” (PRO-GRAMMED TIME OF SYSTEM OFF)	Displays the time programmed to stop.
	DISPLAY “ ☺ NO. ” (TIME NO.)			Displays the time No. only when used in conjunction with the central remote controller.	
5	DISPLAY “PROGRAM ↵ START.” (PROGRAMMING START)	The light turns on when the timer is programmed.	13	CLOCK ADJUSTING BUTTON “  ”	Press this button to set the present time.
	DISPLAY “ OFF ” (HOLIDAY SETTING)			Lights above the day of the week set as holiday. The operation controlled by timer is not available on that day.	
7	DISPLAY “ — ” (SETTING OF DAYS OF A WEEK)	Flashes below the day of the week programmed.	15	BUTTON FOR SELECTING DAYS OF A WEEK “  ”	Press this button to select the day of the week.
	DISPLAY “  ” (MALFUNCTION CODE)			Displays the contents of malfunction during the stop due to malfunction.	

17	TIMER ON BUTTON “  ”
	Press this button to set the present time and the programmed time.
18	HOLIDAY SETTING BUTTON “  ”
	Press this button to set holidays.
19	BUTTON FOR COPYING PROGRAM OF PREVIOUS DAY “  ”
	Use this button to set the No. of programmed time same as that of the previous day.
20	PROGRAM CANCELING BUTTON “  ”
	Use this button to set the programmed time to cancel. The display shows “ - ; - - ”.
<p>(Note)</p> <p>1. Please note that all the displays in the figure appear for explanation purpose or when the cover is open.</p>	

OPERATION

■ Setting present time (Fig. 3)

(Example) In case of setting Friday, 5:30 p.m.

1.  Press the **CLOCK ADJUSTING BUTTON**. The present time display flashes.

(NOTE)

- The present time needs adjusting in case of turning power supply on for the first time or the occurrence of power failure over the period of 48 hours or more.

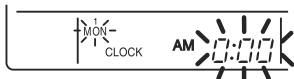

2.  Press the **BUTTON FOR SELECTING DAYS OF A WEEK**. Each time the button is pressed, the day display shifts to the right.

(NOTE)

- The display “ MON ” follows the display “ SUN. ”

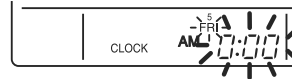

Set the day to Friday.

3.  Set the time with the **HOUR/MINUTE BUTTON**. Each time the HOUR/MINUTE BUTTON is pressed, the display is put forward minute by minute and hour by hour. When the button is kept pressed, the display is put forward continuously.

(NOTES)

- After becoming “ AM 11:00 ”, when the button is pressed, the display becomes “ PM 0:00 ”.
- After becoming “ 59 ” (minute), when the button is pressed, the display becomes “ 00 ” (minute).

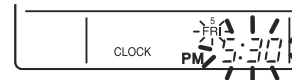

Set the time to 5:30 p.m.

4.  Press the **TIMER ON BUTTON** the moment the time signal of TV, radio, telephone, etc. is heard. The mark “ : ” flashes, and the clock starts.

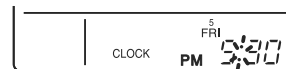

Press the **TIMER ON BUTTON** in tune with the time signal at 5:30 p.m.

(NOTES)

- The clock used is of 12-hour type.
- When you turn power supply on, the system may display “ 88 ” for about one minute and not start to operate after all the liquid crystal displays appear at a time.
- If the **CLOCK ADJUSTING BUTTON** is pressed by mistake, press it again to return to the original state. As the clock does not stop, the time indicated by the clock is kept correct. In case of power failure within 48 hours, the clock keeps operating by utilizing the built-in battery.

■ **Setting no. of programmed time (Fig. 4)**

(Example) Time No. 5 (to be programmed only when used in conjunction with the central remote controller)

Monday to Friday:

Operating from 8:45 a.m. till 5:00 p.m.
Operating from 5:15 p.m. till 11:00 p.m.

Saturday and Sunday:

Setting the whole day stop operation (application for holidays) controlled by programmed time.

1. Press the PROGRAMMING START BUTTON. Programming is available. The display “PROGRAM ↵ START” appears, and the display of days of a week flashes.

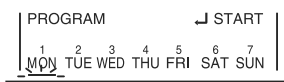

2. Press the TIME No. BUTTON, and select the desired number.

(NOTE)

- Unless used in conjunction with the central remote controller, The TIME No. is not displayed and can not be selected.

Select the TIME No. 5.

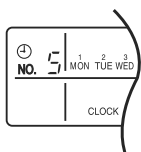

3. Press the BUTTON FOR SELECTING DAYS OF A WEEK, and set the proper day of the week. Each time you press it, the flashing display of days of a week shifts to the right.



Set to Monday.

(1) **Setting programmed time**

4. Set the programmed time of system start 1 by using the HOUR/MINUTE BUTTON. Each time the HOUR/MINUTE BUTTON is pressed, the display is put forward minute by minute and hour by hour. When the button is kept pressed, the display is put forward continuously.



Set the “PROGRAMMED TIME OF SYSTEM START 1” at 8:45 a.m.

5. Press the TIMER ON BUTTON, and set the programmed time of system start 1. Each time you press it, the next area to be set flashes.

(NOTE)

- Set the other programmed time in the same procedure.

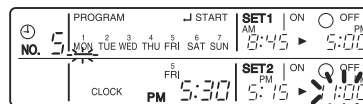

- (2) **Set the next day of the week.**
Set the day of the week to Tuesday, and copy the program of the previous day (Monday). In the same procedure, set the day of the week to Wednesday through Friday in sequence.

- 6.  **Press the BUTTON FOR SELECTING DAYS OF A WEEK and set the following day. Press the BUTTON FOR COPYING PROGRAM OF PREVIOUS DAY. The same program as that of the immediately preceding day of the week is set.**

(NOTE)

- Repeat each procedure 3 – 5 in the above when not copying the contents of the previous day.

(3) **Holiday setting**

- 7.  **Press the BUTTON FOR SELECTING DAYS OF A WEEK and set one or more days of the week as holiday. Press the HOLIDAY SETTING BUTTON, and the display “ OFF ” is displayed at the top of the day of the week. If you press it again, the display returns to the original state.**

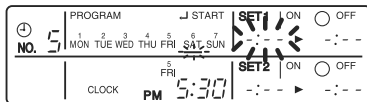

Set Saturday and Sunday as holidays.

- 8.  **Press the PROGRAMMING START BUTTON, and finish the program setting.**

(NOTES)

- Unless the button is pressed within 20 minutes, the display will automatically revert back to the original state. In this case, setting contents up to the point where the TIMER ON BUTTON (or HOLIDAY SETTING BUTTON or BUTTON FOR COPYING PROGRAM OF PREVIOUS DAY) is pressed will only take effect.
- The display “ PROGRAM ↵ START ” and the display of days of a week “ — ” disappears.

- The flashing display goes off, and the No. of programmed time of the present day is displayed. Then the operation controlled by timer starts.
- The operation controlled by timer is executed even while the program is being set.





This is the end of the setting example.

■ **Change and cancellation of no. of programmed time (Fig. 5)**

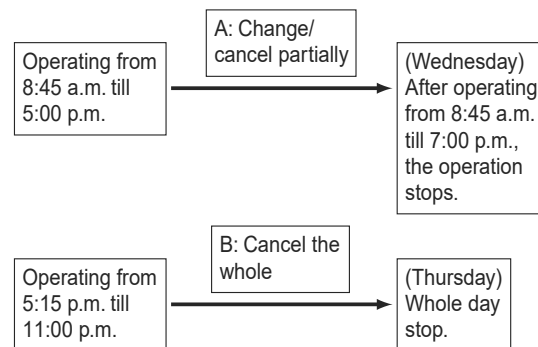
(Example) **Time No. 3 (to be set only when used in conjunction with the central remote controller)**



-  **Press the PROGRAMMING START BUTTON. The program setting is ready. The display “ PROGRAM ↵ START ” appears, and the display of days of a week flashes.**
-  **Press the TIME No. BUTTON, and select the desired No.**



Select the time No. 3.

3.  Press the **BUTTON FOR SELECTING DAYS OF A WEEK**, and set the day of the week to be changed. The set No. of programmed time of the day of the week is displayed.

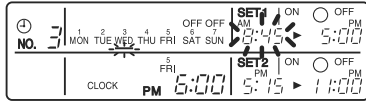

Set the day to Wednesday.

A. Change/cancel partially

4.  Press the **TIMER ON BUTTON** and change, and the display of programmed time flashes. Each time you press it, the next area to be set flashes.



Shift to the display “PROGRAMMED TIME OF SYSTEM OFF 1”.

5.  Press the **HOUR/MINUTE BUTTON** and change the programmed time. Press the **TIMER ON BUTTON**, and finalize the setting of change.

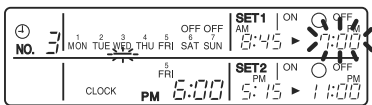

Change the “PROGRAMMED TIME OF SYSTEM OFF 1” to 7:00 p.m.

6.  Press the **PROGRAM CANCELING BUTTON**, and cancel the programmed time. If you press it again, display returns to the original state. Press the **TIMER ON BUTTON** to finalize the cancellation.

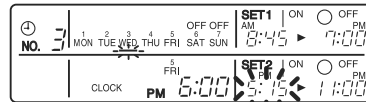

Shift to the “PROGRAMMED TIME OF SYSTEM START 2”.

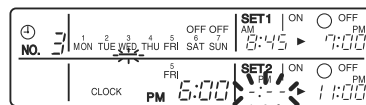

Set the “PROGRAMMED TIME OF SYSTEM START 2” to program cancellation.

In the same procedure, cancel the programmed time of system off 2.

B. Cancel the whole

7.  Press the **BUTTON FOR SELECTING DAYS OF A WEEK**, and shift to the day of the week to be canceled. Then, press the **HOLIDAY SETTING BUTTON**, the display “OFF” appears at the top of the particular day of the week. The programmed time is canceled. If you press the button again, the display returns to the original state.

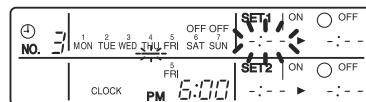

Shift the day of the week to Thursday to set as a holiday.



8.  **Press the PROGRAMMING START BUTTON. The program setting is now finished.**

(NOTES)

- Unless the button is pressed within 20 minutes, the display will automatically revert back to the original state. In this case, setting contents to the point where the **TIMER ON BUTTON** (or **HOLIDAY SETTING BUTTON** or **BUTTON FOR COPYING PROGRAM OF PREVIOUS DAY**) is pressed will only take effect.
- To continue the change/cancellation, do not press the **PROGRAMMING START BUTTON** until all change/cancellation are completed.
- The operation controlled by timer is executed even while the program is being set.

■ Manual operation (Fig. 6)

This schedule timer enables the operation/stop by pressing the **UNIFIED OPERATION/STOP BUTTON** in addition to the operation controlled by timer (operation/stop according to the programmed time) at any time.

1.  **Press the UNIFIED OPERATION BUTTON, and the OPERATION LAMP turns on.**
2.  **Press the UNIFIED STOP BUTTON, and the OPERATION LAMP is turned off.**

(NOTES)

- The operation automatically stops according to the programmed time of system off even during the manual operation. In the meantime, the operation starts automatically according to the programmed time of system start even during the stop of operation.
- If the unit is used in conjunction with other optional controllers for centralized control, the **OPERATION LAMP** of the unit that is not under operation control may be turned on or off a few minutes behind schedule. This shows that the signal is being exchanged, and does not indicate any failure.

Operation lamp

- Turn on: The light turns on when any of the indoor units is in operation whether the operation is controlled by timer or by hand.
- Turn off: The light turns off when all the indoor units stop.

■ Operation control code

Two different types of operation control codes can be selected when this kit is used independently (when not used in conjunction with the central remote controller, unified ON/OFF controller, etc.).

Individual

In case where the operation/stop is controlled by both schedule timer and remote controller.

Centralized

The operation is controlled by the schedule timer alone, and the operation/stop is controlled freely with the remote controller during the programmed time.

(NOTES)

- For current settings, contact your DAIKIN dealer.
- To change settings, contact your DAIKIN dealer.
Do not change settings yourself.

■ Error diagnosing function (Fig. 7)

This schedule timer is provided with the malfunction diagnosing function. The malfunction code flashes if there occurs any malfunction in communication, etc. between and among the optional controllers for centralized control. In addition, the operation lamp also flashes if there occurs any malfunction in communication with the indoor unit. Check the contents of the display and contact your DAIKIN dealer because the signals give you the idea of the trouble area.

Operation lamp	Malfunction code	Contents of malfunction
Turn off	M1	Failure of PC board of schedule timer. Fixes The following causes are possible. Check each one. 1. PC board problems
Turn on or off	M8	Malfunction of transmission between each optional controllers for centralized control. Fixes Check all central devices which are connected (e.g., power supply, transmission wiring, etc.).
Turn on or off	MA	Improper combination of optional controllers for centralized control. Fixes The following causes are possible. Check each one. 1. Are all central devices combined correctly? 2. Is the master central connector attached to two or more central devices? 3. Are there 128 or more indoor units connected?

Turn on or off	MC	Address failure of schedule timer. Fixes The following causes are possible. Check each one. 1. Do the control range addresses in the central remote controller overlap? 2. Do the control range addresses in the on/off controller overlap? 3. Are there 2 or more schedule timers connected?
Flash	UE	Malfunction of transmission between indoor unit and optional controllers for centralized control. Fixes Inspect all indoor units which are displaying an error (e.g., power supply, transmission wiring, etc.).
Flash	—	Malfunction in indoor unit (Refer to the malfunction codes of the indoor remote controller, while also read the "CAUTION FOR SERVICING" attached to the indoor unit.)

QUESTION AND ANSWER

Question	Answer
It is possible to make settings twice a day, but is it possible to make only the "off" setting? (To avoid forgetting to turn the unit off.)	Yes. Press the PROGRAM CANCELING BUTTON in the " ^{AM/PM} 12:00 ^{ON} " section in order to set it to "OFF".

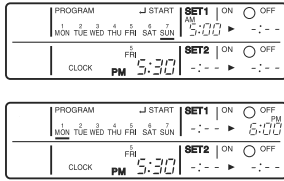
<p>Is it possible to set times which straddle days?</p>	<p>Yes, it is possible. Example: Start operation at 5:00 a.m. on Sunday Stop operation at 6:00 p.m. on Monday</p> 
<p>The unit does not turn on even though the set "on" time has come. (When using the schedule timer alone)</p>	<p>The following causes are possible.</p> <ol style="list-style-type: none"> 1. Are the "on" time and the "off" time set to the same time?
<p>The unit does not turn on even though the set "on" time has come. (When using the unit with a central remote controller)</p>	<p>The following causes are possible. Check each one.</p> <ol style="list-style-type: none"> 1. Was the timer number set with the central remote controller? Was an incorrect timer number set? 2. Is another timer no. set with the central remote controller set for "off" at the same time? 3. Is the operation code set to "remote control permission timer" using the central remote controller or the on/off controller?
<p>The unit operates even though that day is set as a holiday. (When using the unit with a central remote controller)</p>	<p>The following causes are possible.</p> <ol style="list-style-type: none"> 1. Is another timer number set with the central remote controller set for "on" at the same time? (If two timer numbers are set, make sure that the settings for holidays and working days do not overlap between the different timer numbers.)

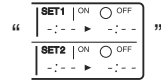
<p>The TIME NO. is not displayed.</p>	<p>The following causes are possible.</p> <ol style="list-style-type: none"> 1. The TIME NO. is not displayed when using the schedule timer alone. (It can be set if using the central remote controller at the same time.)
<p>The display remains</p>  <p>even though I push the HOUR/MINUTE BUTTON in the timer program settings.</p>	<p>The following causes are possible.</p> <ol style="list-style-type: none"> 1. Is the day set to a holiday?
<p>I cannot set "central management priority" or "after-push priority" with the schedule timer.</p>	<p>The following causes are possible.</p> <ol style="list-style-type: none"> 1. Is a central remote controller or on/off controller also installed? * The priority order of the operation codes depends on the central devices which are installed. The below operation codes are set. <ul style="list-style-type: none"> • Schedule timer Central remote controller is used as well Operation code of the central remote controller • Schedule timer On/off controller is used as well Operation code of the on/off controller • Schedule timer Central remote controller On/off controller is used as well Operation code of the central remote controller

13.14 <KRP928BB2S> Interface Adaptor for DIII-NET

Safety Precautions

- Read these Safety Precautions carefully to ensure correct installation. This manual classifies precautions into WARNING and CAUTION.

WARNING : Failure to follow WARNING is very likely to result in such grave consequences as death or serious injury.

CAUTION : Failure to follow CAUTION may result in serious injury or property damage, and in certain circumstances, may result in a grave consequence.

Be sure to follow all the precautions below ; they are all important for ensuring safety.

WARNING

- Installation should be left to the dealer or another qualified professional.**
Improper installation by yourself may cause malfunction, electrical shock, or fire.
- Install the set according to the instructions given in this manual.**
Incomplete or improper installation may cause malfunction, electrical shock, or fire.
- Be sure to use the standard attachments or the genuine parts.**
Use of other parts may cause malfunction, electrical shock, or fire.
- Disconnect power to the connected equipment before starting installation.**
Failure to do so may cause malfunction, electrical shock, or fire.
- A ground fault circuit interrupter / an earth leakage circuit breaker should be installed.**
If the breaker is not installed, electrical shock may occur.

CAUTION

- Do not install the set in a location where there is danger of exposure to inflammable gas.**
Gas accumulated around the unit at the worst may cause fire.
- To prevent damage due to electrostatic discharge, touch your hand to a nearby metal object (doorknob, aluminum sash, etc.) to discharge static electricity from your body before touching this kit.**
Static electricity can damage this kit.
- Lay this cable separately from other power cables to avoid external electrical noises.**
- After installation is complete, test the operation of the PCB set to check for problems, and explain how to use the set to the end-user.

1. Overview, Features and Compatible Models

This kit is the interface required when connecting the central controller and a Room Air Conditioner. Use of the central controller makes it possible to perform the following monitoring and operations. It is compatible with room air conditioners which have an HA connector S21.

- Run / stop for the central controller and wired remote controller, operating mode selection, and temperature can be set.
- The operating status, any errors, and the content of those errors can be monitored from the central controller and wired remote controller.
- Run / stop for the central controller and wireless remote controller, operating mode selection, and the temperature setting can be limited by the central controller.
- Zone control can be performed from the central controller.
- The unit can remember the operating status of the air conditioner before a power outage and then start operating in the same status when the power comes back on.
- Card keys, operating control panels, and other constant / instantaneous connection-compatible equipment can be connected.
- The Operating / error signals can be read.
- The indoor temperature can be monitored from the iTM / iTC.

Precaution

- When reading the Operating / error signals, a separate external power source (12 V DC) is needed.
- A separate timer power source (16 V DC) is needed when using the schedule timer independently, and not in conjunction with other central controllers.
- The range of temperatures that can be set from the central controller is 18°C to 32°C in cooling and 14°C to 28°C in heating.
- Fan operation cannot be selected from the central controller or wired remote controller.
- Group control (i.e., control of multiple indoor units with a single remote controller) is not available.
- Monitoring is not available of the thermo status, compressor operating status, indoor fan operating status, electric heater, or humidifier operating status.
- Forced thermo off, filter sign display and reset, fan direction and speed settings, air conditioning fee management, energy savings instructions, low-noise instructions, and demand instructions cannot be made.
- Since a stop due to a momentary power failure cannot be detected, automatic operating start may not be possible.

2. Component Parts

This kit includes the following components. Check to ensure that none of these are missing.

Parts	Q'ty	Parts	Q'ty
Kit assy	1	Connection harness (about 1.8m)	1
PCB is in the housing.		Mounting screws	3
		Binding band	6
		Installation manual	2
		Seal	2

3. Names of Parts and Electric Wiring

<Wiring procedure>

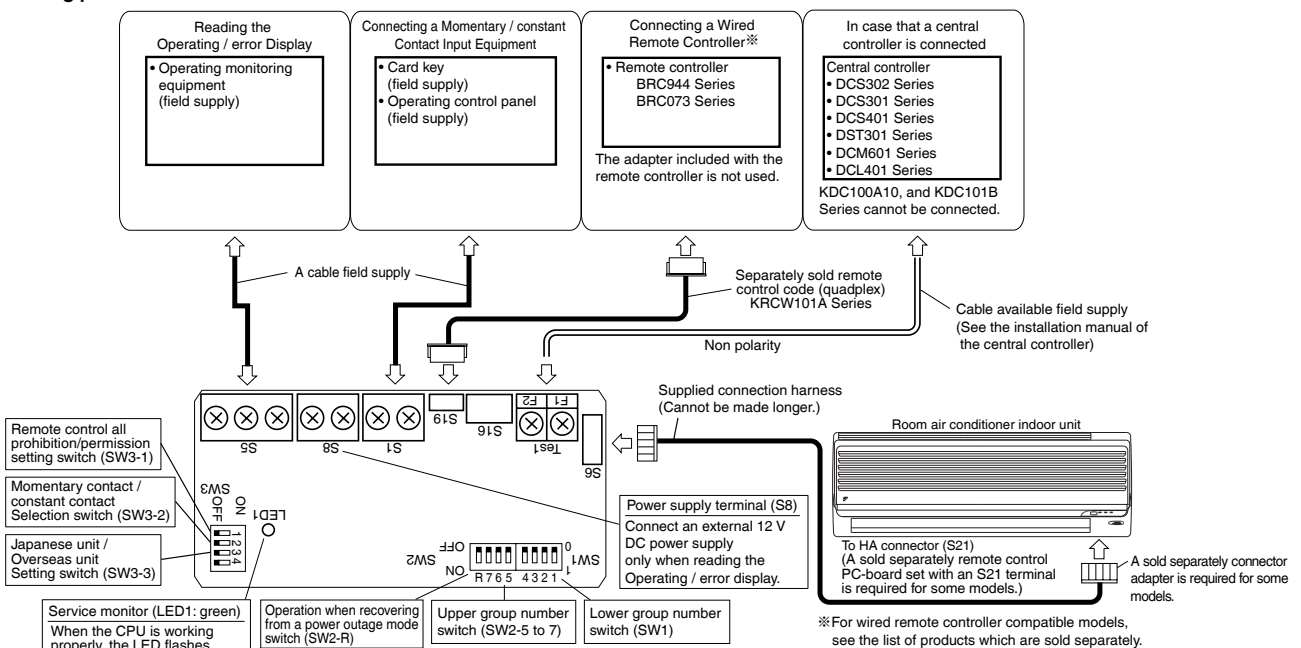

4. Switch Settings

NOTE Turn the power on after all the switches have been set. Settings made while the power is on are invalid.

Open the Kit's case and set the switches on the circuit board.
 (1) For Overseas / Japanese unit setting (SW3-3)
 Room air conditioners, different methods are used for setting the temperature in automatic mode, so this switch needs to be set.

Destination	SW3-3 setting	What Happens
Japan	OFF (Factory setting)	• "Automatic" operation is not available from the central controller. When using "automatic" operation using the wireless remote controller, the central controller displays automatic cooling (heating) and 25°C. Even if the temperature is changed, it will return to 25°C after a while.
Overseas	ON	• "Automatic" operation is available from the central controller.

(2) Group number settings (SW1 and SW2-5 to SW2-7)
 Set these when using the central controller. (Set to the  side.) Do not set more than one unit to the same number.
 Use SW2-R for (3) Settings when recovering from a power outage.

However, these settings do not need to be made when using the schedule timer independently.
 (The settings are needed when used in conjunction with another DCS Series central controller.)
 In this case, the schedule timer performs an auto address after the power is turned on, so new group numbers are automatically set. Settings made using the switches will be overwritten.

Group NO. Settings table (Enlarged section SW1 and SW2 in "3. Names of Parts and Electrical Wiring")

Group NO. Upper settings SW2		Group NO. Lower settings SW1					
1-	5-	00-	04-	08-	12-		
2-	6-	01-	05-	09-	13-		
3-	7-	02-	06-	10-	14-		
4-	8-	03-	07-	11-	15-		

: Use with power failure recovery settings Set to the side : ON : OFF

NOTE also that a separate timer power source is needed when using the schedule timer independently.
 Power source specs: 16 V DC, +10%, -15%, 200mA.

(3) Settings when recovering from a power outage (SW2-R)
 This selects whether to restart operation when the power comes back on after a power outage occurred during operation. This setting is given priority in cases where the indoor unit has an auto start ON / OFF jumper. Note also that regardless of whether switch SW2-R is on or off, the operating mode (NOTE), set temperature, fan direction and speed settings, and remote control prohibition status are stored.

SW2-R setting	What Happens
OFF (Factory setting)	Stops after recovering from a power outage
ON	Stops if the unit was stopped before the power outage and runs if it was running.

(NOTE) The following settings apply to the models below.

Room air conditioner	Mode before power outage	
	COOLING	HEATING
Models with humid heating and dehumidifying functions.	DRY COOLING	HUMID HEATING
Models with dehumidifying function.		HEATING

(4) Contact input function settings (SW3-1 to SW3-2)
 When using contact input (S1), choose one of the following functions.

S1 operating mode	SW3-1 setting	SW3-2 setting	What Happens	Control mode
Instantaneous contact input (factory setting)	OFF	OFF	The operating status of the air conditioner is reversed by an instantaneous input of 100 msec or more.	Last command priority
		ON	Contact - Open to close: air condition runs. Close to open: air conditioner is stopped (NOTE 1).	ON / OFF control is rejected (operate / stop / timer prohibition) (NOTE 2).
Remote control all prohibition/permission input	ON	Invalid	Contact - Open to close: air condition stops. Close to open: no change in operating status.	All remote controller actions are prohibited when the contact is closed. (NOTE 3)

NOTE1: Since central controller uses last command priority, the contact status and operating status of the air conditioner might not match sometimes.
 Example: If the unit is run from the central controller while the air conditioner is stopped with an open contact, the contact will be open and the unit will be running.

NOTE2: Operating mode and fan direction and speed settings can be changed.

NOTE3: If the contact is closed while the ON timer is set, as the power ON timer function is still operating, the operation starts at the time specified by the timer. To prevent operation of the power ON timer, use of the (KRP413BB1S) remote control PC-board set is recommended. However, note that it cannot be used in tandem with the central controller.
 If this product is connected to an air conditioner manufactured in or after 2011, when the contact is closed, the power ON timer may be cancelled depending on the combination with the model.

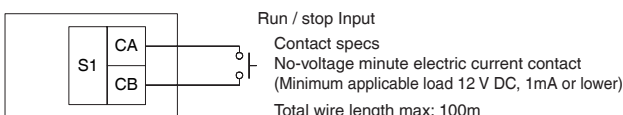

5. Control Codes

When using a central remote controller, the operating codes can be used to limit operation from wireless remote controllers. Three beeps for signal reception will be heard continuously when the wireless remote controller is operated while in central control.
 ○ : permitted; × : prohibited

S1 operating mode	Control mode	Control code	Operations from the remote controller								
			"Run" control from the central controller			"Stop" control from the central controller					
			Run / timer	Stop	Operating mode temperature	Fan direction and fan speed	Run / timer	Stop	Operating mode temperature	Fan direction and fan speed	Operations from central controller and contact input
Instantaneous contact mode	ON / OFF control is rejected	0,1,3 10,11	×	×	×	×	×	×	×	×	
	Only OFF control is accepted	2 12-19	×	×	×	×	×	×	×	×	
	Central priority	4 5	○	○	○	○	×	○	×	×	
	Last command priority	6,7	○	○	○	○	○	○	○	○	
	Timer operation is accepted by remote controller	8 9	○*	○*	○*	○	×	○	×	×	○
Constant contact mode		2,10-19 0,1,3,5-7		×						×	
		4	×	×			×	×		×	
		8			○*				×	×	
		9			○*				○	○	
All remote controller actions are prohibited			×	×	×	×	×	×	×	×	

*Only during timer operation
 The remote controller permission / prohibition settings using the ITM / ITC are as follows.
 ○ : permitted; × : prohibited

S1 pin operating mode	ITM / ITC settings			Operations from the remote controller			Operations from central controller and contact input
	Start / stop	Change operating mode	Change set temperature	Run / timer	Stop	Operating mode temperature	
Instantaneous contact mode • Constant contact mode	ON / OFF control is rejected	permitted	permitted/prohibited	×	×	○	
	Only OFF control is accepted	permitted	permitted/prohibited	×	×	○	
Constant contact mode	permitted	permitted/prohibited	permitted/prohibited	×	×	○	○
	prohibited	permitted/prohibited	permitted/prohibited	×	×	×	
Instantaneous contact mode	permitted	permitted/prohibited	permitted/prohibited	○	○	○	
	prohibited	permitted/prohibited	permitted/prohibited	×	×	×	
Constant contact mode	permitted	permitted/prohibited	permitted/prohibited	×	×	○	
	prohibited	permitted/prohibited	permitted/prohibited	×	×	×	
All remote controller actions are prohibited	Does not affect settings			×	×	×	×

6. Read Operating / Error Display Signal

The Operating / error signals can be read from the contact output (S5).
Output specs
 M1: Turn MR 1 ON when the air conditioner is running.
 M2: Turn MR 2 when a communication error has occurred between the KRP928BB2S and the air conditioner, or MR 1 is ON and the unit has stopped after an error.
 MR 2 is not turned ON during a warning.

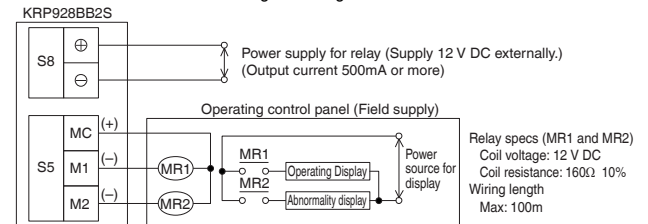

7. Combining Equipment

The central controller can be combined with the following devices.

	Central Remote Controller	ON / OFF controller	Schedule timer	D-BIPS	Contact input	Wired Remote Controller	Wireless Remote Controller
Central Remote Controller	○	○	○	○	○	○	○
ON / OFF controller	○	○	○	○	○	○	○
Schedule timer	○	○	×	×	○	○	○
D-BIPS	○	○	×	×	○	○	○
Contact input	○	○	○	○	×	○	○
Wired Remote Controller	○	○	○	○	○	×	×
Wireless Remote Controller	○	○	○	○	○	×	○

! WARNING

- Do not install the unit in a location where it may be exposed to water.
- Install the unit indoors.

1. Removal of upper HA casing

① Insert a flat-blade screwdriver into the groove between the upper and lower casings.

② Lift the handle of the screwdriver upward.

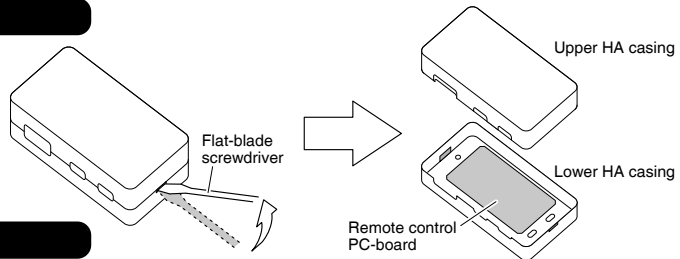

2. Securing of lower HA casing

Mount and secure the lower HA casing directly on the wall with the provided screws inserted into the screw holes (a round hole and two ellipse holes) of the casing.

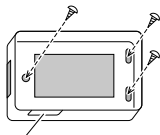

NOTE

Mount so that the wiring through-hole faces downward. If water droplets, dirt, dust, etc., get inside, smoke, fire, or malfunctioning may result.

3. Connection of wiring

Connect the wiring to the connector terminals.

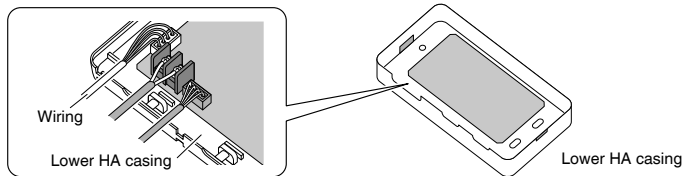

4. Fixation of wiring

① Insert the provided binding band under the pillar of the HA casing and secure the covers of the wiring with the binding band.

② Insert the second binding band into the groove on the side of the HA casing and fix the wiring securely so that the wiring will not be disconnected.

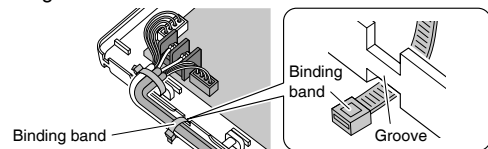
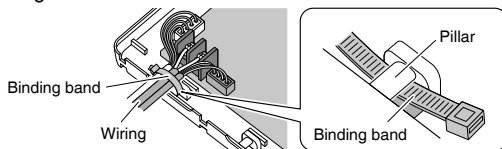

A large number of wires

Make a slit with an appropriate tool, such as a cutter knife, on the thin part of the upper HA casing along the frame. Then cut the part with an appropriate tool, such as a pair of nippers.

(NOTE) Cut off only the thin part required for wiring.

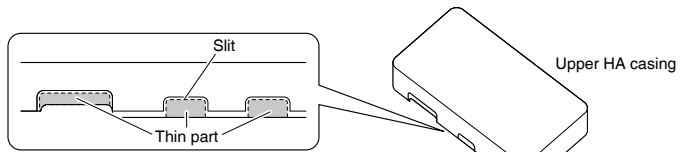

5. Finishing

Mount the upper HA casing to the original position.

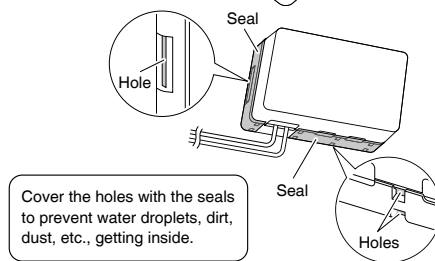
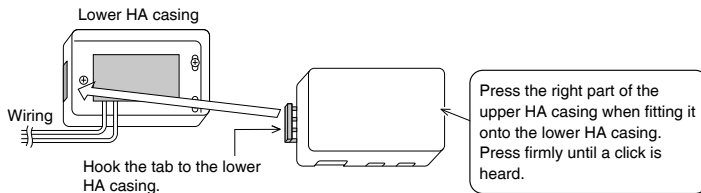

Information

When the contact input device (such as card keys) and central controller are used in tandem:

Even when the operating mode of the S1 pin is set to prohibit all remote controller actions, run/stop operation from the central controller is possible. The operation also starts when the power ON timer of the indoor unit is up while all remote controller actions are prohibited. (*) In this case, stop the operation from the central controller. For the compatible models of the (KRC944 series) remote controller, the operation can be prohibited by using the remote controller in tandem with the central controller. *If this product is connected to an air conditioner manufactured in or after 2011, when the contact is closed, the power ON timer may be cancelled depending on the combination with the model.

13.15 <KRP067A41> Remote Control PC-Board Set

Safety Considerations

- Read these **Safety Considerations** carefully to ensure correct installation.
- This manual classifies the precautions into **WARNING** and **CAUTION**. Be sure to follow all the precautions below: they are all important for ensuring safety.

⚠ WARNING : Failure to follow any of WARNING is likely to result in such grave consequences as death or serious injury.

⚠ CAUTION : Failure to follow any of CAUTION may in some cases result in grave consequences.

⚠ WARNING

- Installation shall be left to the authorized dealer or another trained professional. Improper installation may cause water leakage, electrical shock, fire, or equipment damage.**
- Be sure to use the supplied or exact specified installation parts. Use of other parts may cause the unit to come to fall, water leakage, electrical shock, fire or equipment damage.**
- Be sure to switch off the unit before touching any electrical parts.**
- Be sure to install a ground fault circuit interrupter / earth leakage circuit breaker. Failure to install a ground fault circuit interrupter / earth leakage circuit breaker may result in electrical shock, fire or personal injury.**

⚠ CAUTION

- Do not install the air conditioner where gas leakage would be exposed to open flames. If the gas leaks and builds up around the unit, it may catch fire.**
- Touch a nearby metal object (doorknob, aluminium sash, etc.) to discharge static electricity from your body before touching this set.**
(Static electricity from your body can damage this set.)
- Lay the cable separately from other power cables.**
(Poor wiring may cause external electrical noise.)

- After completing installation, test the unit to check for installation errors. Give the user adequate instructions concerning the use and cleaning of the unit according to the Operation Manual.**

Outline / Features

This set is an interface that connects a central control device to a room air conditioner and allows you to perform the following operations, or monitoring, in combination with the central control device using KRP413AB1S or KRP928BB2S (sold separately).

- Starting and stopping the air conditioner, and setting the mode and temperature, through the central control device or the wired remote controller. (64°F to 90°F (18°C to 32°C) in COOL operation, 57°F to 82°F (14°C to 28°C) in HEAT operation, none in FAN operation)
- Monitoring the operating conditions, occurrence of errors, and contents of errors of the air conditioner through the central control device or the wired remote controller.
- Restricting the operation with a wireless remote controller found near the air conditioner, such as starting and stopping operation, changing the mode, or setting the temperature, through the use of the central control device, coin timer, or card key.
- Zone control through the central control device.
- Restoring the operating conditions of the air conditioner to the previous conditions at the time of power recovery in case of power outage.

This set does not support the following functions.

- Group control (i.e., the control of multiple indoor units through a single remote controller)
- Monitoring of the following items: Indoor temperature and operating conditions of thermo, compressor, indoor fan, electric heater, and humidifier
- Control of the following items: Forced thermo OFF, filter sign display and reset, airflow direction, airflow rate setting, and air-conditioner charge management
- Energy-saving command, low-noise command, and demand command

Components

This set includes the following components. Please confirm them.

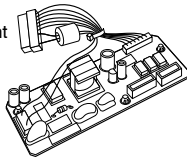
Component	Quantity	Component	Quantity
 Main component	1	Installation Manual	1

Installation Procedure

Installation Position

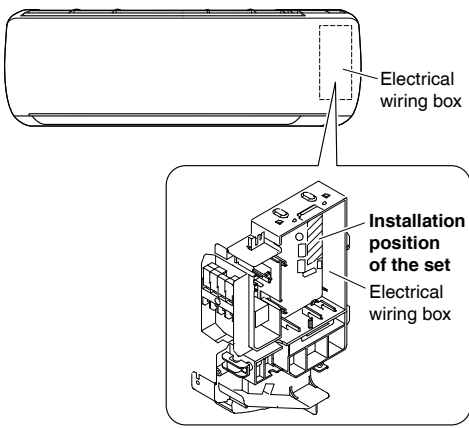

Wiring Outline

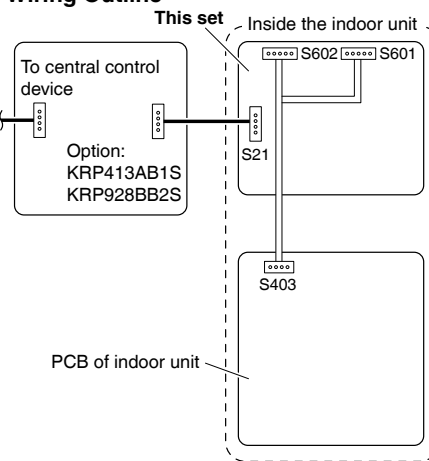

Note:
Wires indicated by thick lines are not included with the set.

Removal and Installation of Front Panel

• Removal method

- 1) Place your fingers in the indentations on the main unit (one each on the left and right sides), and open the panel until it stops.
- 2) Continue to open the front panel further while sliding the panel to the left and pulling it toward yourself in order to disengage the rotating shaft on the left side. To disengage the rotating shaft on the right side, slide the panel to the right while pulling it toward yourself.

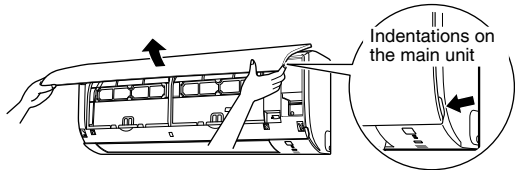

• Installation method

Align the rotating shaft of the front panel with the grooves, and push all the way in. Then close slowly. Push both the sides and the center of the lower surface of the panel firmly.

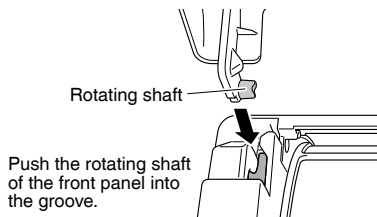

Opening Service Lid of Indoor Unit

The service lid is of removable type.

• Opening method

- 1) Remove the single screw of the service lid.
- 2) Pull out the service lid frontward.

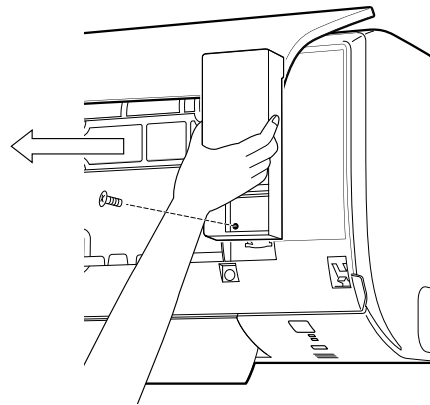

Removal and Installation of Front Grille

• Removal method

- 1) Remove front panel.
- 2) Remove the air filter.
- 3) Remove the screws (2) from the front grille.
- 4) Disengage 3 hooks (the location can be identified by ○○○ mark) at the top of the grille.

< When there is no work space because the unit is close to ceiling >

⚠ CAUTION

Be sure to wear protection gloves.

Disengage the flap (horizontal blade), and pull the lower part of the front grille toward yourself to remove it. If it is difficult to remove, place both hands under the center of the front grille, and while pushing up, pull it toward yourself.

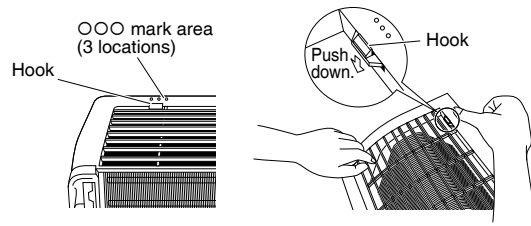
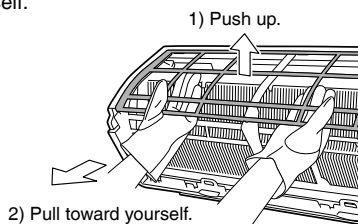

• Installation method

- 1) Install the front grille and firmly engage the upper hooks (3 locations).
- 2) Insert 2 screws of the front grille.
- 3) Install the air filter then mount the front panel.

Removal of Electrical Wiring Box Cover

1. Remove the front panel and the front grille and service lid of indoor unit.
(Refer to the front page for the removal of each part in detail.)
2. Remove the electrical wiring box cover.

⚠ WARNING

- Be sure to turn OFF the power at the time of installation work.
Touching any electric parts with the power turned ON may cause electric shock.

Electrical wiring box
If there is workspace on the right-hand side of the indoor unit, the installation work can be conducted without removing the electrical wiring box.

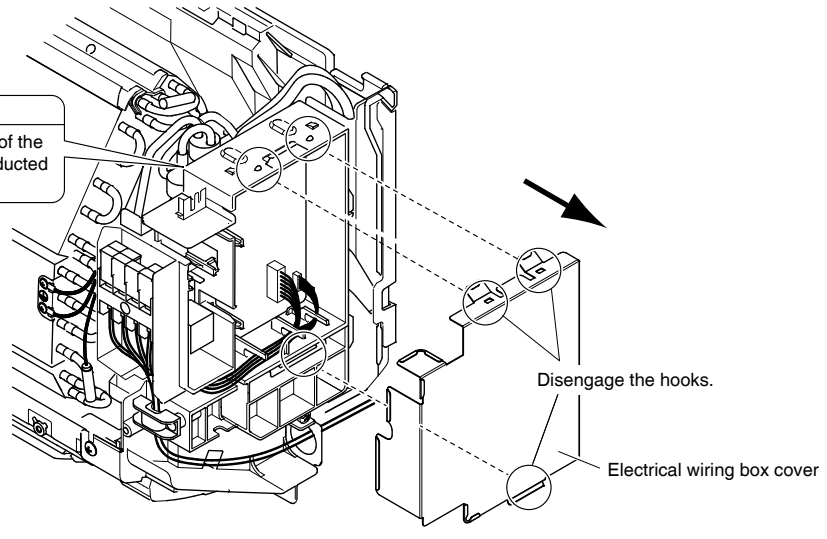

After connecting the HA PCB (this set), return all removed parts to their original positions.

Removal of Electrical Wiring Box

If there is workspace on the right-hand side of the indoor unit, the installation work can be conducted without removing the electrical wiring box. Connect HA without removing the electrical wiring box, if possible.

1. Disconnect the inter-unit wire.
2. Disconnect the fan motor connector (S200) and swing motor connector (S6).
3. Disconnect the thermistor and ground/earth wire from the heat exchanger (2 screws).
(Some models may not have ground/earth wire.)
4. Remove the mounting screw of the electrical wiring box (1 screw).

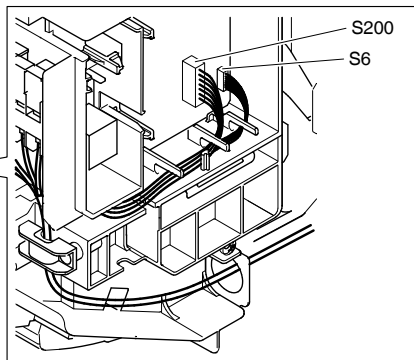
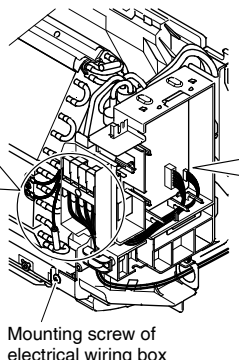
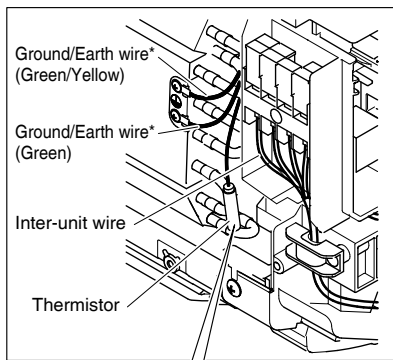

Make sure that the mounting bracket of the thermistor will not fall off.

*The position of the ground/earth wire may differ depending on the model

After connecting the HA PCB (this set), return all removed parts to their original positions.

Connecting HA PCB

1. Install the HA PCB (this set). (See Fig. 1)

- 1) Install the HA PCB (this set) to the electrical wiring box.
- 2) Insert the connector of the HA PCB (this set) to the connector (S403) on the electrical wiring box.

2. Connect the HA connection cord. (See Fig. 1 and 2)

- 1) Insert the HA connection cord into the HA connector "S21" (white) on the HA PCB (this set).
- 2) Route the HA connection cord as shown in Fig. 2.

Fig. 1 Connection points of the HA PCB

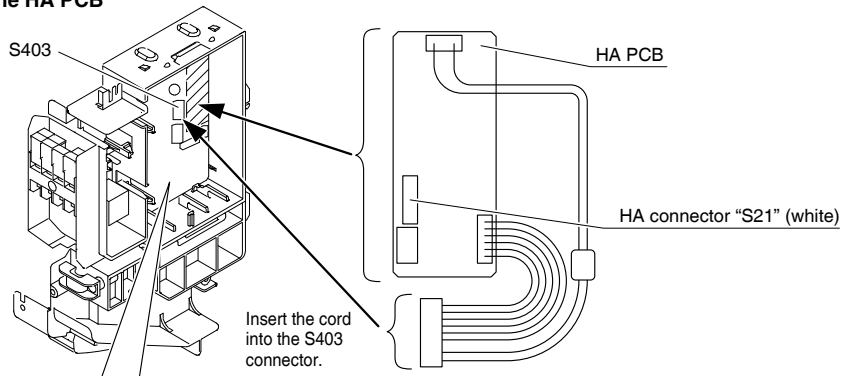

Installing HA PCB on the electrical wiring box

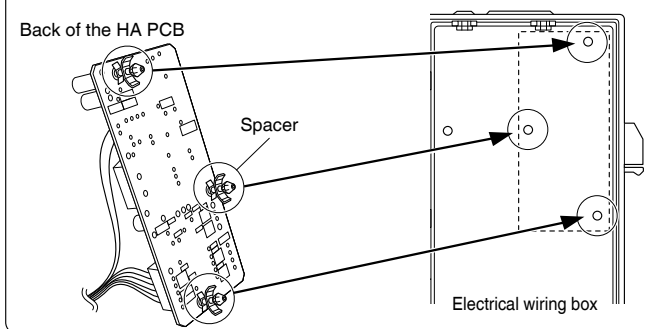
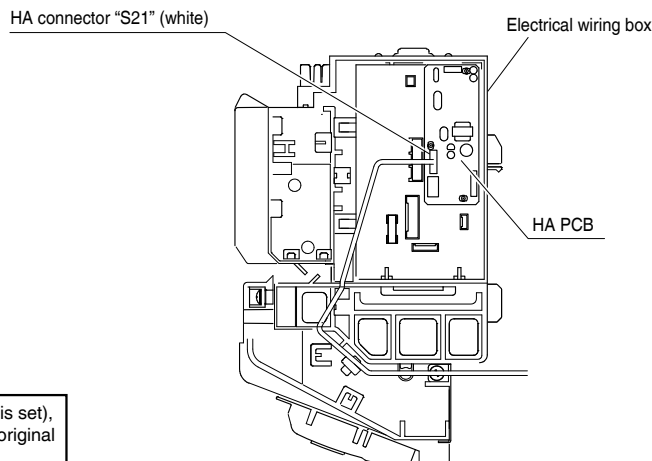







Fig. 2 Routing HA connection cord



After connecting the HA PCB (this set), return all removed parts to their original positions.

13.16 <KPW937F4> Air Direction Adjustment Grille

Component parts Be sure to check that the following parts are included before installation.

Name	①Air direction adjustment grille	②M 4 × 3 0 Screw	③Installation manual	④Seal	⑤Spacer
Shape					
Qty.	1 pc.	4 pcs.	3 sheets.	L=385: 1pc, L=355: 2pcs.	4 pcs.

- Selection of installation site**
- Use the air direction adjustment grille for installation at a location that fits the following conditions.
 1. When installing the outdoor unit near the neighbouring house.
 2. When changing the airflow direction to prevent exhaust blowing directly onto passersby or garden plants.

- Cautions for usage**
- Be sure to perform the following as installation precautions to ensure correct and safe use of the air direction adjustment grille.
 1. Be sure to stop the operation before installation.
 2. Avoid short-circuits during installation.
 3. When using the unit in areas with snow, install the grille to create a left-right or downward airflow. Do not install the grille to create an upward airflow to prevent snow accumulating in the air outlet of the outdoor unit as this may damage the unit.
 4. Be careful of foreign substances such as dead leaves, which may accumulate on the air outlet after installing the grille to create an upward airflow.
 5. Do not use screws other than those provided. Tighten the screws securely without any looseness.

- Installation of air direction adjustment grille**
- Pitch of the installation screws for the air direction adjustment grille(①) is 434mm in the vertical and horizontal directions.
 - Installation can be performed in 4 directions: top, bottom, left and right.
 - Temporarily secure the air direction adjustment grille(①) using 4 screws(②), check the installation angle, and then tighten the screws.

Steel wire outlet grille

- Seals(④) and spacers(⑤) are not necessary.

1 Remove the 4 outlet grille fixing screws.

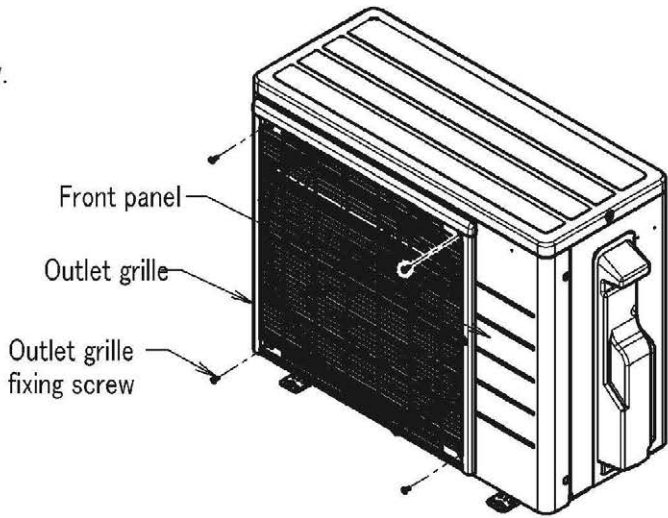

The diagram shows a perspective view of the outdoor unit. Labels with arrows point to the 'Front panel' at the top, the 'Outlet grille' on the front face, and 'Outlet grille fixing screw' at the bottom corners of the grille area.

- 2 Install the air direction adjustment grille(1) attached on the front panel using 4 screws(2).

※ Attach the air direction adjustment grille on top of the outlet grille using the same screws.

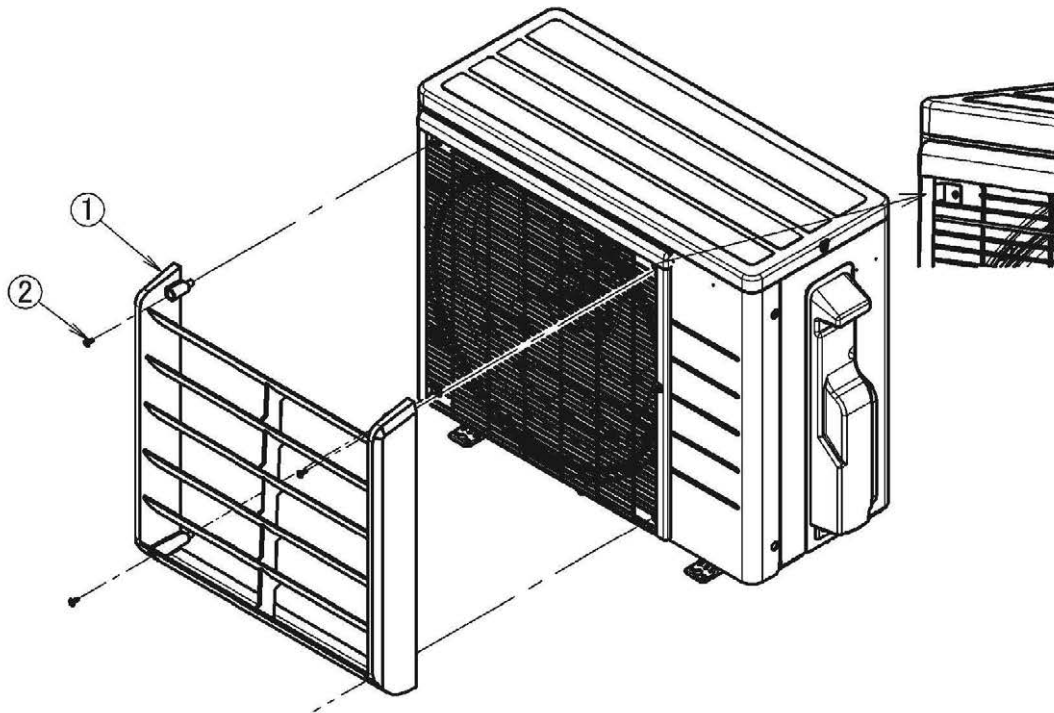

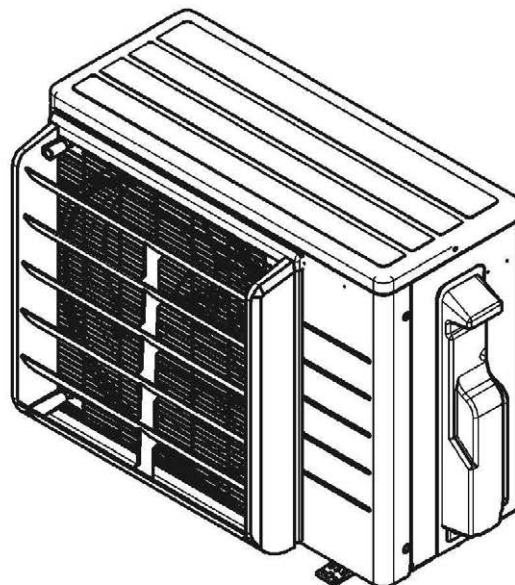

- 3 Appearance of the air direction adjustment panel following installation.
(When installed with the louvers facing up.)



13.17 <KKG067A41> Back Protection Wire Net

Component parts

Name	① Protection net	② Installation manual
Shape		
Q'ty	1pc	1sheet(this sheet)

Caution

Be sure to wear protection gloves when performing installation work as the fins on the heat exchanger may cause injury.

Part names

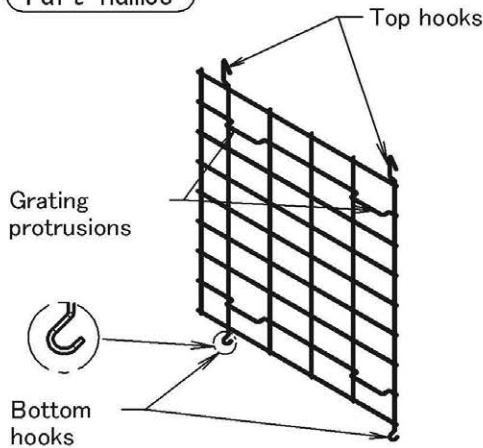

1 Verify the location at which the protection net (①) is to be installed.

Attach the protection net (①) so that the vertical grating is aligned with the outside edge of the installation leg on the right side of the outdoor unit.

Positioning line when installing the protection net (①)

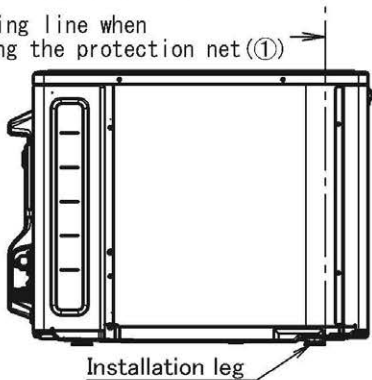

2 Attach the protection net (①)

Orient the protection net (①) so that the horizontal grating protrusions are facing the heat exchanger and insert the two bottom hooks between the heat exchanger and the bottom frame.

Insert the two top hooks between the heat exchanger and the top panel while flexing the protection net (①).

※ Be careful not to install the protection net upside down.

Be careful not to damage the heat exchanger's cooling tubes.

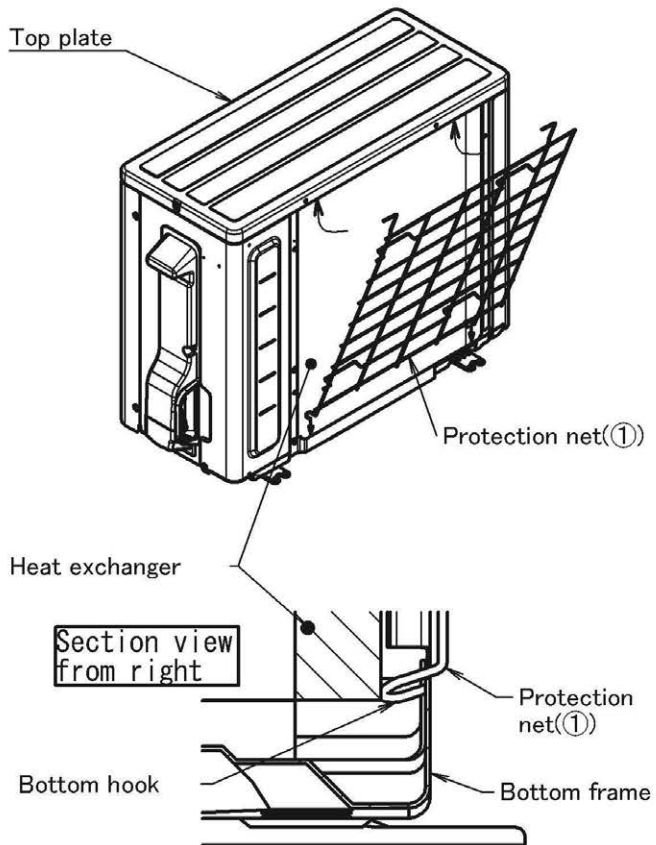



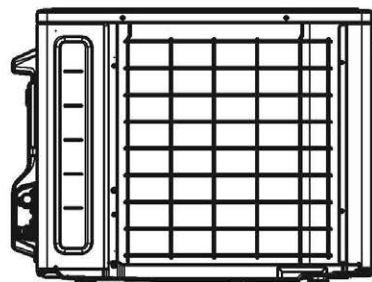



3 Appearance of the protection net (①) following installation

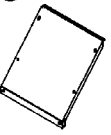

13.18 <KPS067A41> Snow Hood (Side)

Parts Before assembling the product, verify that all of the following parts have been included:

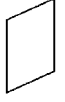
Name	Side plate (left)	Side plate (right)	Top plate	Front plate	Screws	Piercing screw	Installation Manual
Illustration	① 	② 	③ 	④ 	⑤ 	⑥ 	⑦ 
Quantity	1	1	1	1	8	1	1 (this document)

⚠ Caution Read these safety considerations for installation carefully before installing the product.

- Be sure to observe the following installation precautions to ensure that the product can be used safely:
 1. Install the product so that it is situated high enough to allow access to the outdoor unit for maintenance.
 2. Installing the product in a location in which it may be exposed to strong winds, secure the outdoor unit with wire or other means.
 3. Choose a location where the operating sound will not cause a nuisance to the neighbors of the user.
 4. Tighten screws securely. Failure to do so may result in vibration.

⚠ Caution
 Indicates a potentially hazardous situation which, if not avoided, may result in minor or moderate injury. It may also be used to alert against unsafe practices.

1 Installing the snow hood (intake side plate)

1 Attach the side plate (left) ①

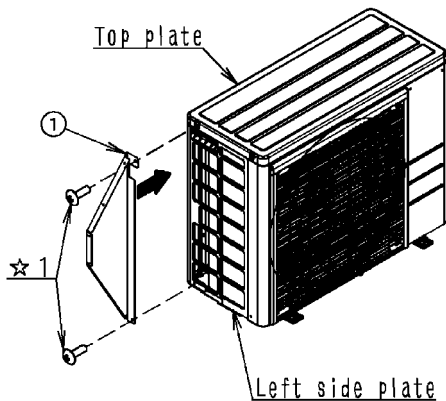

1. Remove the two screws (marked "☆ 1" in the figure) that hold the outdoor unit's top plate, bottom frame, and front plate in place and use them to attach the side plate (left) ①.

When using with KPS067A42 (snow hood [intake rear plate])

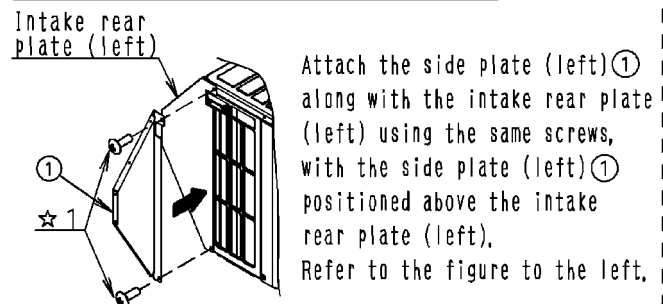

2 Attach the side plate (right) ②

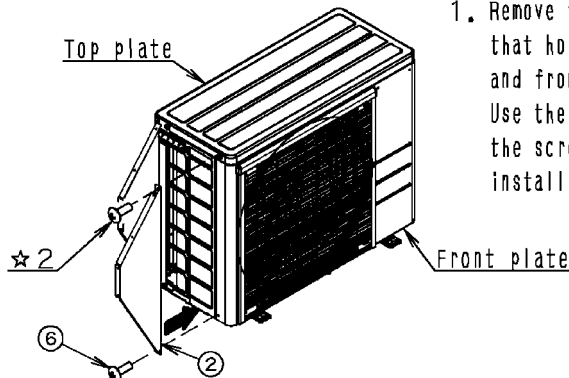

1. Remove the screw (marked "☆ 2" in the figure) that hold the outdoor unit's top plate, and front plate in place and use the ⑥ piercing screws supplied with the screws and kit that were removed, install a side plate (right) ②.

3 Attach the top plate ③ and front plate ④.

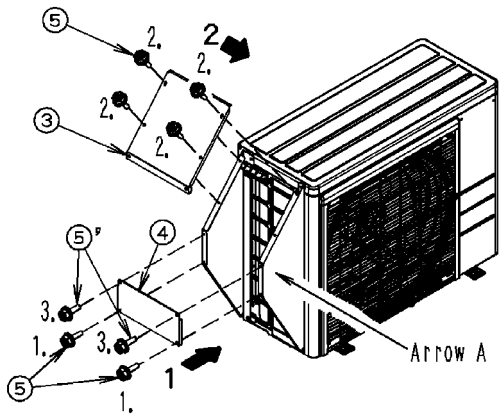

1. Aligning the creases on the left and right sides of the front plate ④ with the outer surfaces of the side plate (left) ① and the side plate (right) ②, temporarily secure the front plate ④ in place with the 2 screws ⑤.
2. Temporarily secure the top plate ③ from above the front plate ④ with the 4 screws ⑤.
3. Temporarily secure the top plate ③ and the front plate ④ with the 2 screws ⑤'. (See arrow A.)

*The side plate (left) (1), side plate (right) ②, top plate ③, and front plate ④ should be positioned as shown in the following figure:

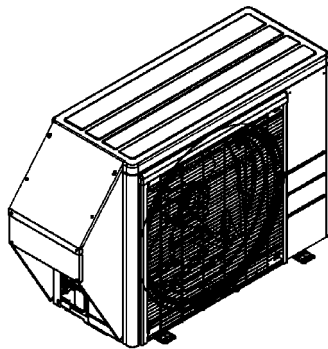
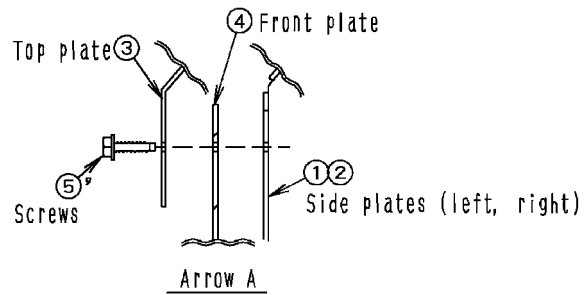

4. Securely tighten the 8 screws ⑤ with which the plates were temporarily secured in steps 1), 2), and 3).

2 Appearance of the snow hood (intake side plate) following installation

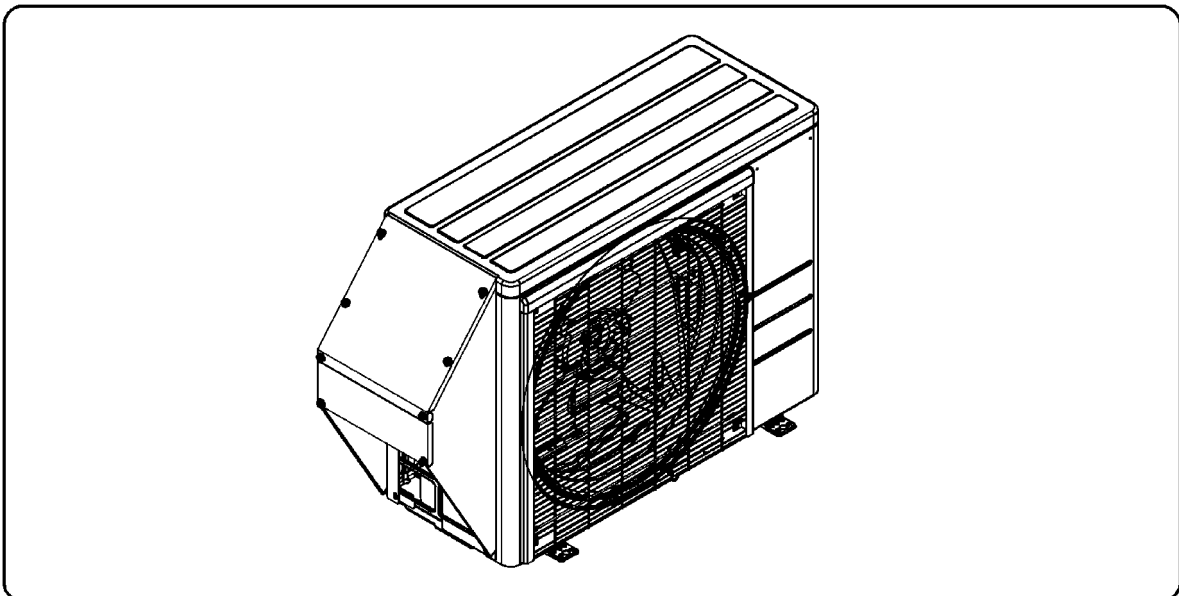

13.19 <KPS067A42> Snow Hood (Rear)

Parts Before assembling the product, verify that all of the following parts have been included:

Name	Side plate	Side plate	Top plate	Front plate	Screws	Piercing screw	Installation Manual
Illustration	① (Left)	② (Right)	③	④	⑤	⑥	⑦
Quantity	1	1	1	1	8	2	1 (this document)

⚠ Caution Read these safety considerations for installation carefully before installing the product.

- Be sure to observe the following installation precautions to ensure that the product can be used safely:
 1. Install the product so that it is situated high enough to allow access to the outdoor unit for maintenance.
 2. Installing the product in a location in which it may be exposed to strong winds, secure the outdoor unit with wire or other means.
 3. Choose a location where the operating sound will not cause a nuisance to the neighbors of the user.
 4. Tighten screws securely. Failure to do so may result in vibration.

⚠ Caution
 Indicates a potentially hazardous situation which, if not avoided, may result in minor or moderate injury. It may also be used to alert against unsafe practices.

1 Installing the snow hood (intake rear plate)

1 Attach the side panel (left) ①.

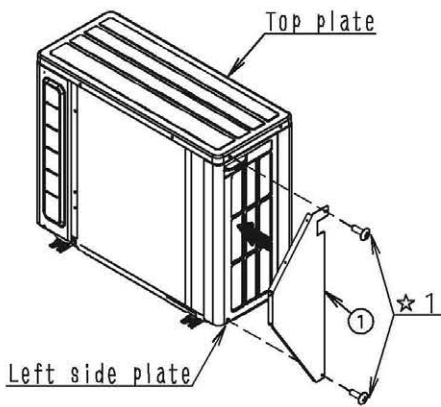

1. Remove the 2 screws (marked "★1" in the figure) that hold the outdoor unit's top plate, left side plate, and bottom frame and use them to attach the side plate (left) ①.

***When using with KPS067A41 (snow hood [intake side plate])**

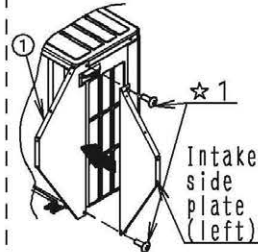

Attach the side plate (left) ① along with **the intake side plate (left)** using the same screws, with the side plate (left) ① positioned below the intake side plate (left). Refer to the figure to the left.

2 Attach the side plate (right) ②.

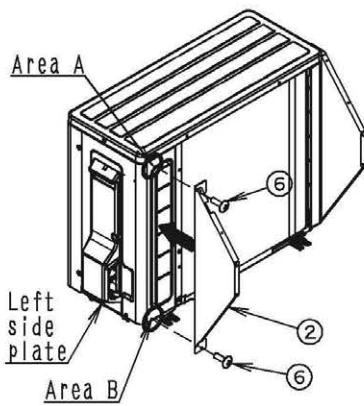

1. Attach by tightening the 1 piercing screw ⑥ into the dowel hole in the right side plate (area A) and the 1 piercing screw ⑥ into the screw hole in the bottom frame (area B).

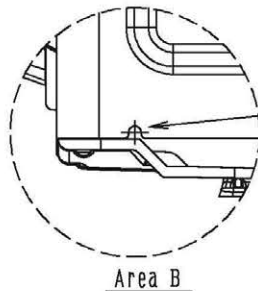

*If using an electric screwdriver, be careful not to overtighten the screws.
 The fixed location

3 Attach the top plate ③ and the front plate ④.

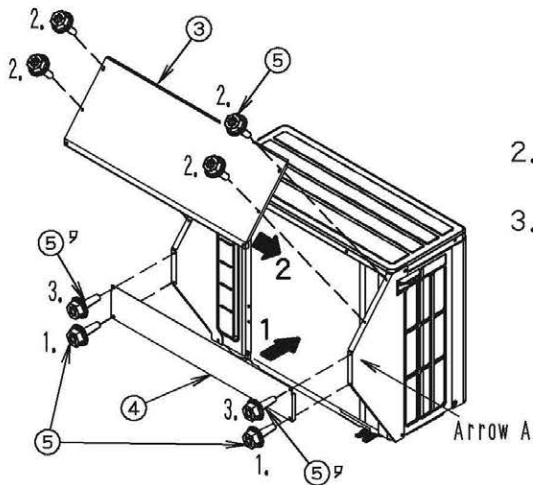

1. Aligning the creases on the left and right sides of the front plate ④ with the outer surfaces of the side plate (left) ① and side plate (right) ②, temporarily secure the front plate ④ in place with the 2 screws ⑤.
2. Temporarily secure the top plate ③ from above the front plate ④ with the 4 screws ⑤.
3. Temporarily secure the top plate ③ and the front plate ④ with the 2 screws ⑤. (See arrow A.)

*The side plate (left) (1), side plate (right) ②, top plate ③, and front plate ④ should be positioned as shown in the following figure:

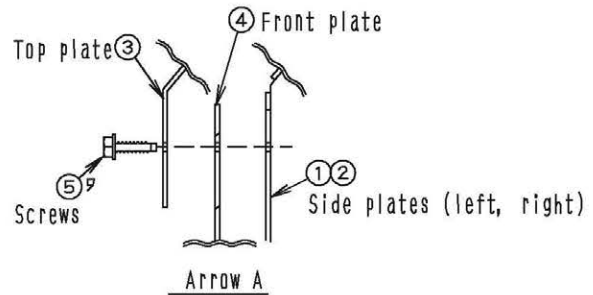

4. Securely tighten the 8 screws ⑤ with which the plates were temporarily secured in steps 1), 2), and 3).

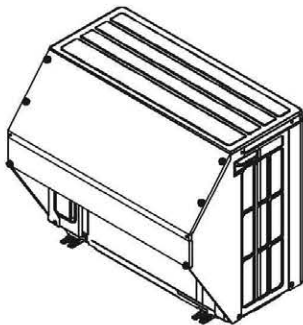



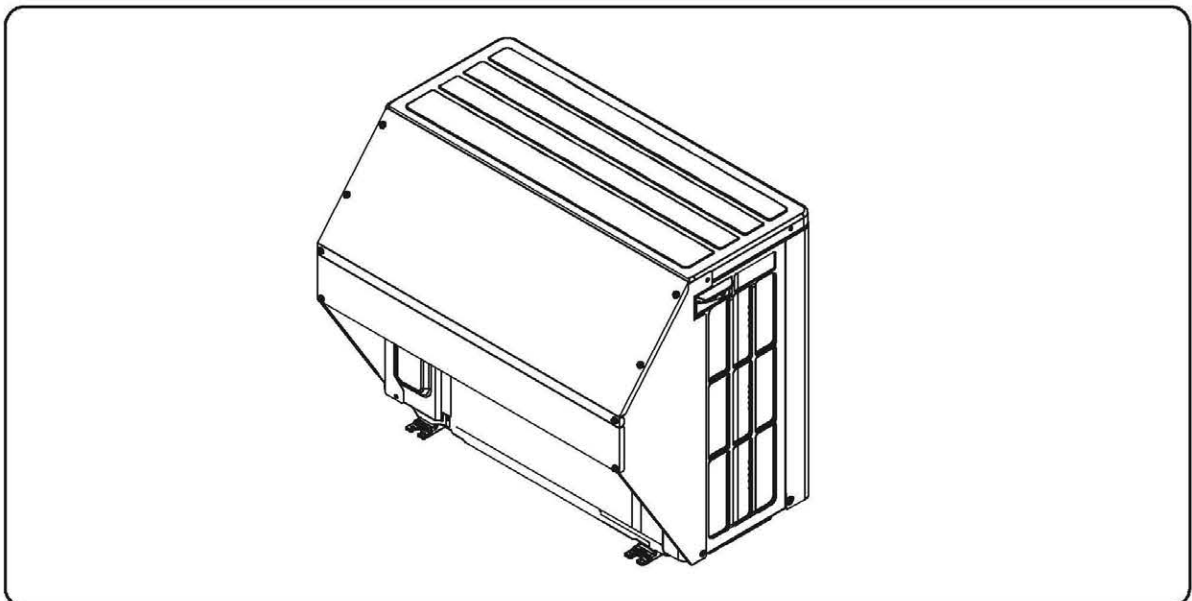

2 Appearance of the snow hood (intake rear plate) following installation

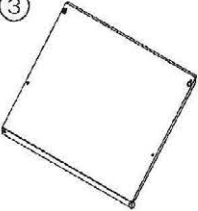

13.20 <KPS067A44> Snow Hood (Discharge)

Parts Before assembling the product, verify that all of the following parts have been included:

Name	Side plate	Side plate	Top plate	Screws	Installation Manual
Illustration	① (Right) 	② (Left) 	③ 	④ 	⑤ 
Quantity	1	1	1	6	1 (this document)

⚠ Caution Read these safety considerations for installation carefully before installing the product.

● Be sure to observe the following installation precautions to ensure that the product can be used safely:

1. Install the product so that it is situated high enough to allow access to the outdoor unit for maintenance.
2. Installing the product in a location in which it may be exposed to strong winds, secure the outdoor unit with wire or other means.
3. Choose a location where the operating sound will not cause a nuisance to the neighbors of the user.
4. Tighten screws securely. Failure to do so may result in vibration.

⚠ Caution
Indicates a potentially hazardous situation which, if not avoided, may result in minor or moderate injury. It may also be used to alert against unsafe practices.

① Installing the snow hood (outlet)

① Remove the discharge grille.

1. Remove the 4 screws that hold the discharge grille, then remove the discharge grille.

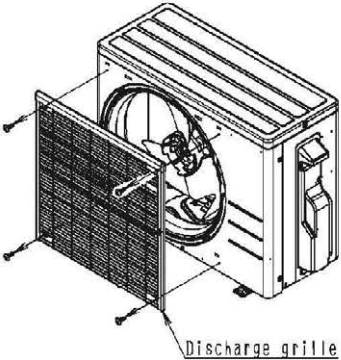

Discharge grille

2 Attach the side plate (left) ② and side plate (right) ①.

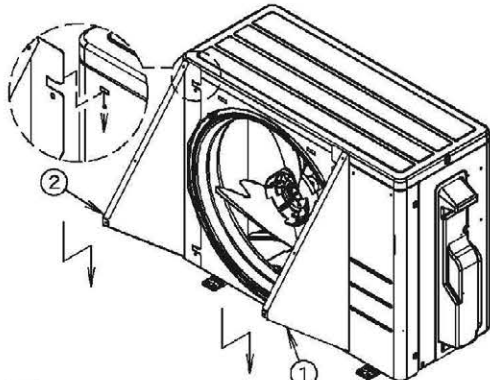

1. Insert the hooks in the side plate (right) ① and side plate (left) ② respectively into the holes provided in the front plate.

3 Attach the discharge grille.

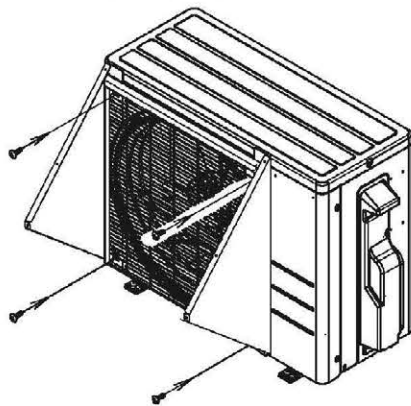

1. When installing the discharge grille removed in [1], jointly tighten the side plate (right) ① and side plate (left) ② with the 2 screws that hold the discharge grille for each plate.

4 Attach the top plate ③

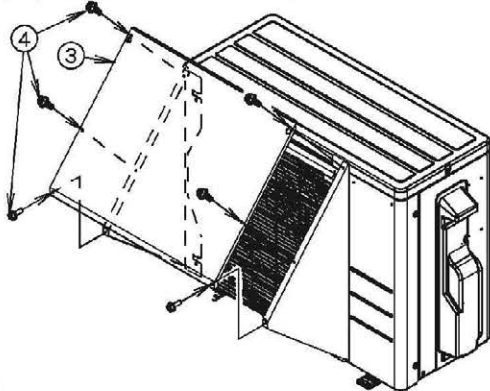

1. Install the top plate ③ using the 6 screws ④ included in the kit.

• Installation is easiest if you start with the hook slot.

2 Appearance of the snow hood (outlet) after installation

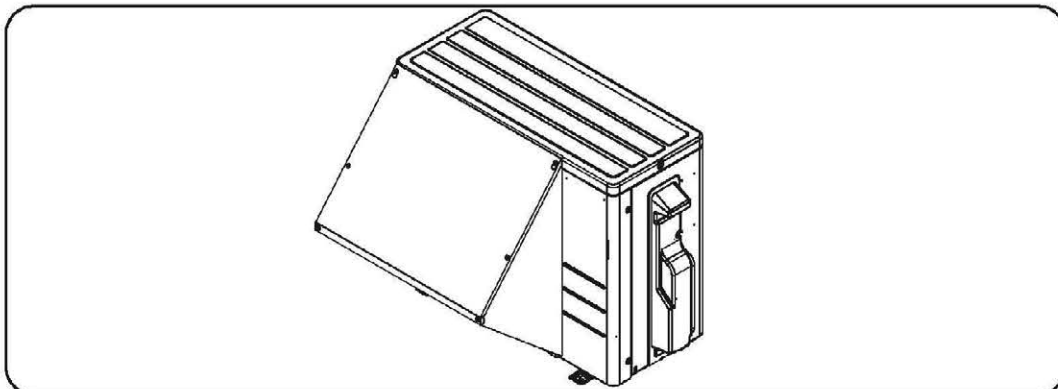

Warning ● Ask a qualified installer or contractor to install this product. Do not try to install the product yourself. Improper installation can result in water or refrigerant leakage, electrical shock, fire or explosion.



- Use only those parts and accessories supplied or specified by Daikin. Ask a qualified installer or contractor to install those parts and accessories. Use of unauthorized parts and accessories or improper installation of parts and accessories can result in water or refrigerant leakage, electrical shock, fire or explosion.
- Read the user's manual carefully before using this product. The user's manual provides important safety instructions and warnings. Be sure to follow these instructions and warnings.

If you have any inquiries, please contact your local importer, distributor and/or retailer.

Cautions on product corrosion

1. Air conditioners should not be installed in areas where corrosive gases, such as acid gas or alkaline gas, are produced.
2. If the outdoor unit is to be installed close to the sea shore, direct exposure to the sea breeze should be avoided. If you need to install the outdoor unit close to the sea shore, contact your local distributor.