



Date:

Specification Sheet for Daikin High Efficiency Small Cabinet 3 to 6 Ton
Flush Mount Concentric Diffuser with 18" Dia. Collars

Part Number:
Daikin PN: 0270L01603
MicroMetl PN: 1017-200A-DKN

Submitted To:

Job:

Notes:

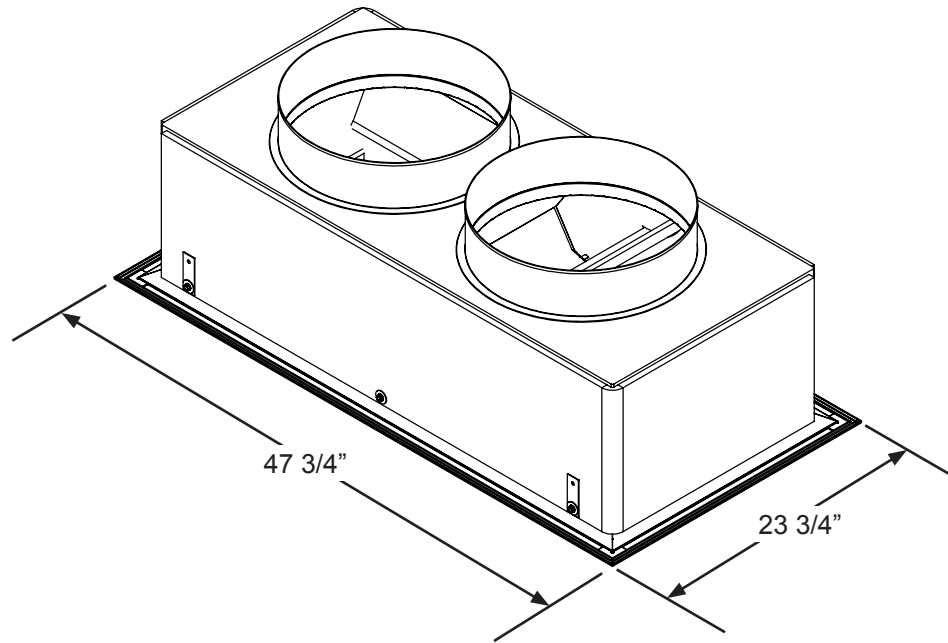

Notes:

1. Includes supply and return duct collars for 18" diameter collars.
2. Flush mount grille constructed of brushed aluminum. Supply air around perimeter and return air through the center.
3. Includes hanging brackets on both sides.
4. Return air boot constructed of fiberglass.
5. Package includes turning vanes for smooth 4 way supply air distribution.

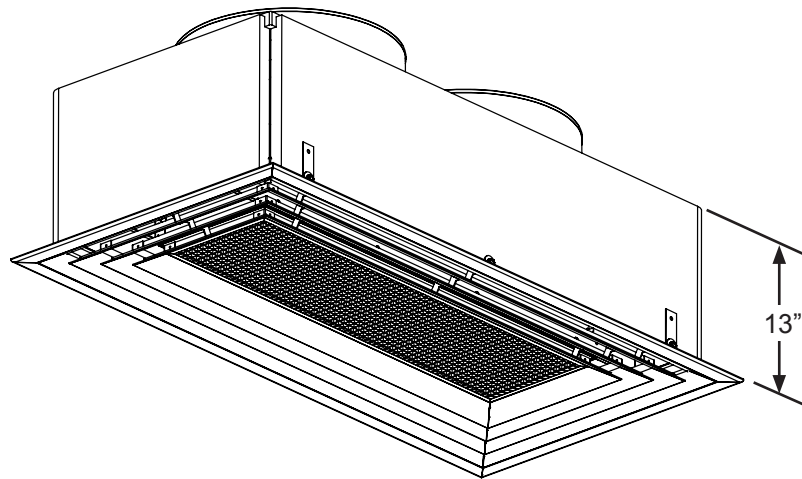

Product Operating Weight:
35 Lbs

The Information contained in this drawing is the sole property of MicroMetl Corporation. Any reproduction in part or whole without the written permission of MicroMetl Corporation is prohibited.