



ECONOMIZER 101

Economizers are designed to provide “free” air conditioning when outside conditions are appropriate. When the outside air is cool and dry enough, the economizer automatically opens to introduce the cool air to the interior space, thereby eliminating the need to run the air conditioning compressor.

If the outside air becomes too warm or humid, the economizer automatically closes the fresh air damper and the compressor engages to begin cooling the space mechanically.

If a two stage thermostat is used it is possible to use a combination of economizer and mechanical cooling to condition the space.

The economizer can also be set to allow a minimum amount of fresh air to enter the space when the equipment’s indoor blower is operating.

Economizers are valuable tools to enhance indoor air quality, save energy and prolong the life of the air conditioning equipment.

INSTALLATION

1. Open the containers and inspect the contents for shortages and damage.
2. Remove the large evaporator access panel from the package unit and discard. Remove the smaller filter access panel. **Retain screws for attaching economizer hood.**
3. Slide the base plate into the opening with the wider flange toward the outside of the unit and place it over the return air opening. It should be centered between the evaporator opening side posts. (Figure 1)
4. Slide the damper rack into the large opening until the front flange is against the evaporator support bracket. (Figure 2)

Figure 1



Figure 2

5. Slide the damper rack to the right until the damper side flanges are even with the evaporator access panel opening flange. The top flange of the damper rack should be even with or just inside the top cap of the unit. (Figure 3&4)

Warranty: Honeywell Jade components have 5 year parts warranty.
Workmanship and all other parts, 1 year parts only

Figure 3



Figure 4



6. Assemble the fresh air/ barometric relief hood using the instructions in this document.
7. Install the hood assembly taking care to slide the top flange of the hood under the top cap of the unit.
8. Secure the hood with the screws from step 2.
9. Install the mist eliminators and secure them using the latches provided.
10. Locate the unit economizer 6 pin plug inside the evaporator section near the filter access opening and plug it into the corresponding 6 pin plug on the economizer.

NOTE: Ensure neither the wire nor the plugs interfere with the movement of the dampers during operation.

11. Seal the hood using silicone or other approved method to ensure a watertight seal.
12. Replace the blower and filter access panel.
13. Consult the DDC literature that has been provided with the Rooftop Unit for proper setup of the DDC kit. The economizer will not function correctly if the DDC controller is not configured properly.

| CONTENTS | |
|----------|----------------------------|
| QTY | DESCRIPTION |
| 1 | INTERNAL DAMPER w/ACTUATOR |
| 1 | BASE PLATE SUB-ASSEMBLY |
| 1 | INSTALLATION INSTRUCTIONS |

ACCESSORIES / CAPABILITIES

Power Exhaust - SPE180300X, 145-DK-14X or 146-DK-14X power exhausts are used in applications where barometric relief is not sufficient.

Important Notes

The fresh air mist eliminator should be flushed periodically with warm soapy water.

1. CONNECT HOOD SIDE 1 AND SIDE 2 TO DIVIDER WITH PROVIDED 5/16 HEAD SCREWS.
2. CONNECT HOOD SIDE 1 AND HOOD SIDE 2 TO HOOD BOTTOM WITH PROVIDED 5/16" HEAD SCREWS.

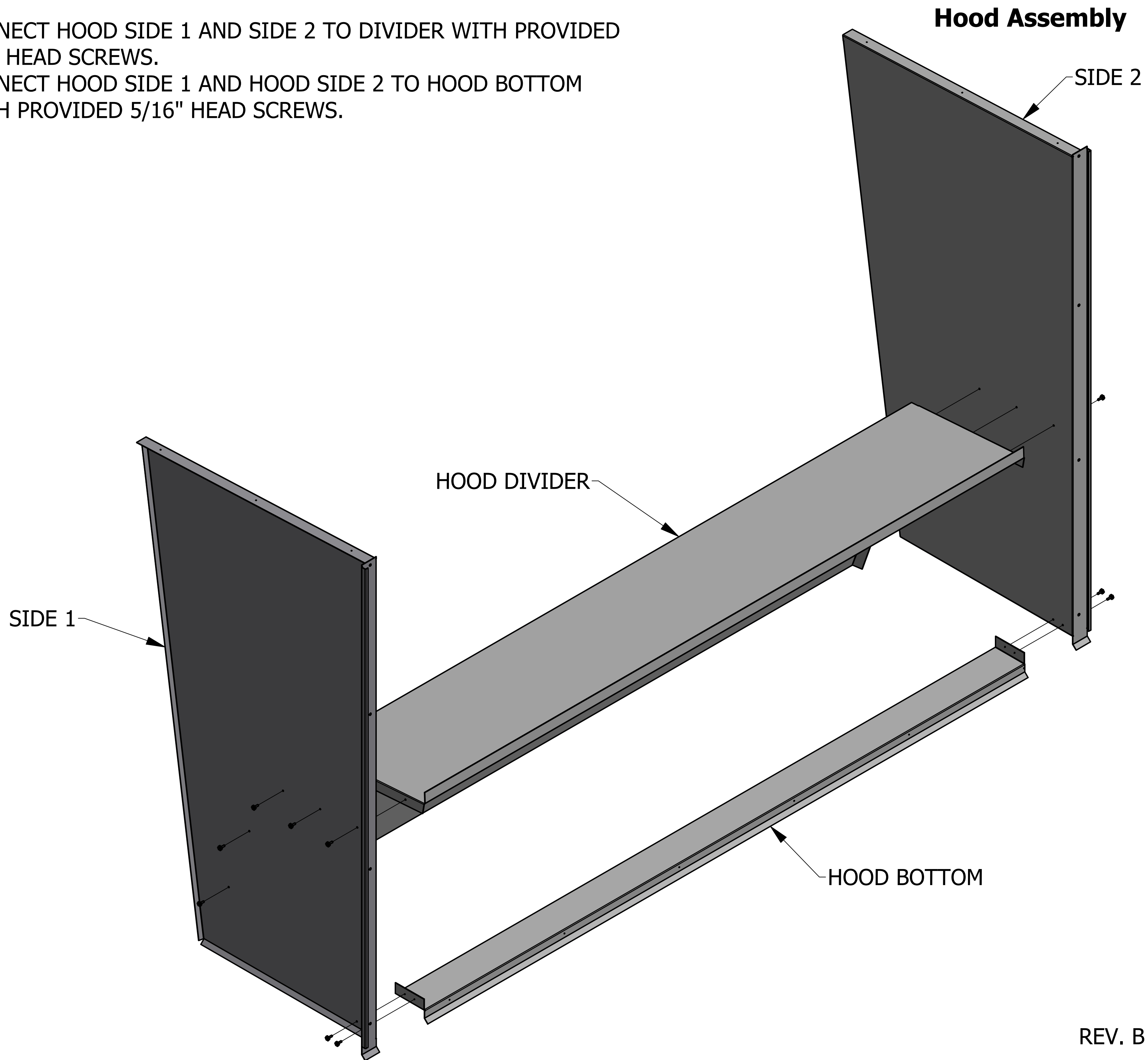

3. CONNECT TOP ASSEMBLY TO SIDES USING PROVIDED 5/16 HEAD SCREWS.

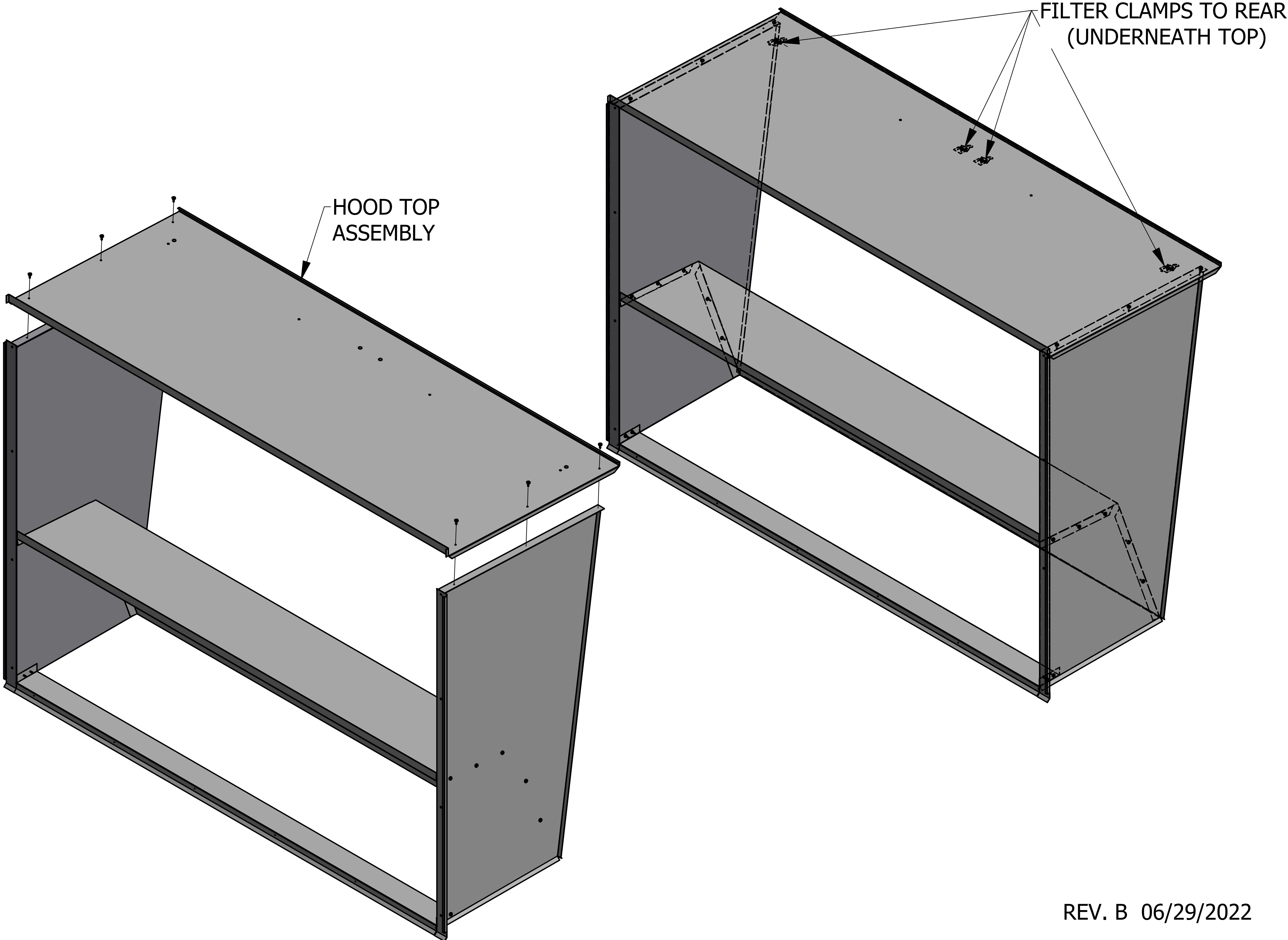

4. SLIDE FILTER RACK ASSEMBLY INTO HOOD IN THE POSITION SHOWN.
5. ATTACH USING THE PROVIDED 5/16" HEAD SCREWS.

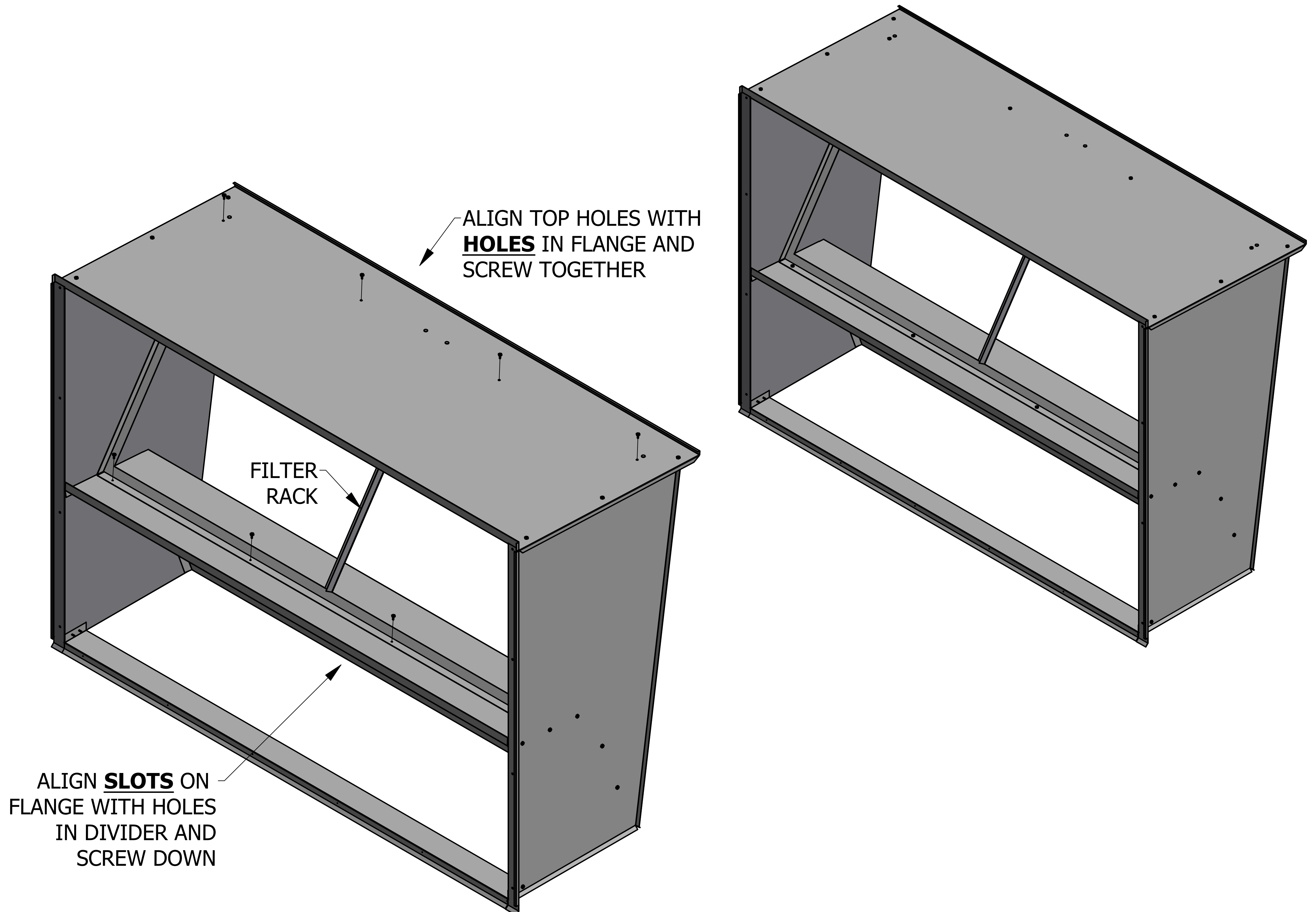

6. INSERT PROVIDED MIST ELIMINATOR FILTERS.
7. FLIP LATCHES DOWN TO SECURE FILTERS.

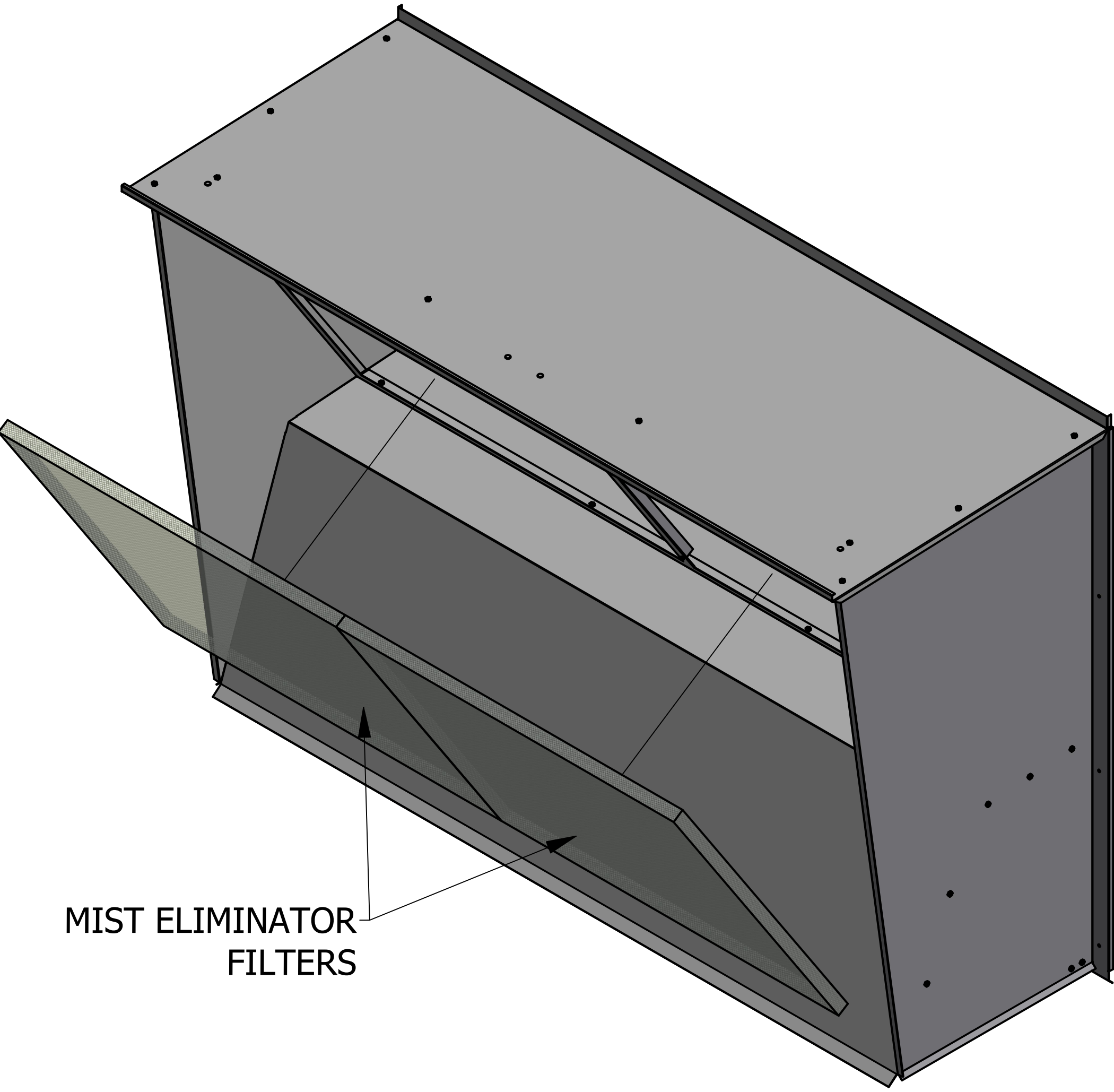

MIST ELIMINATOR
FILTERS

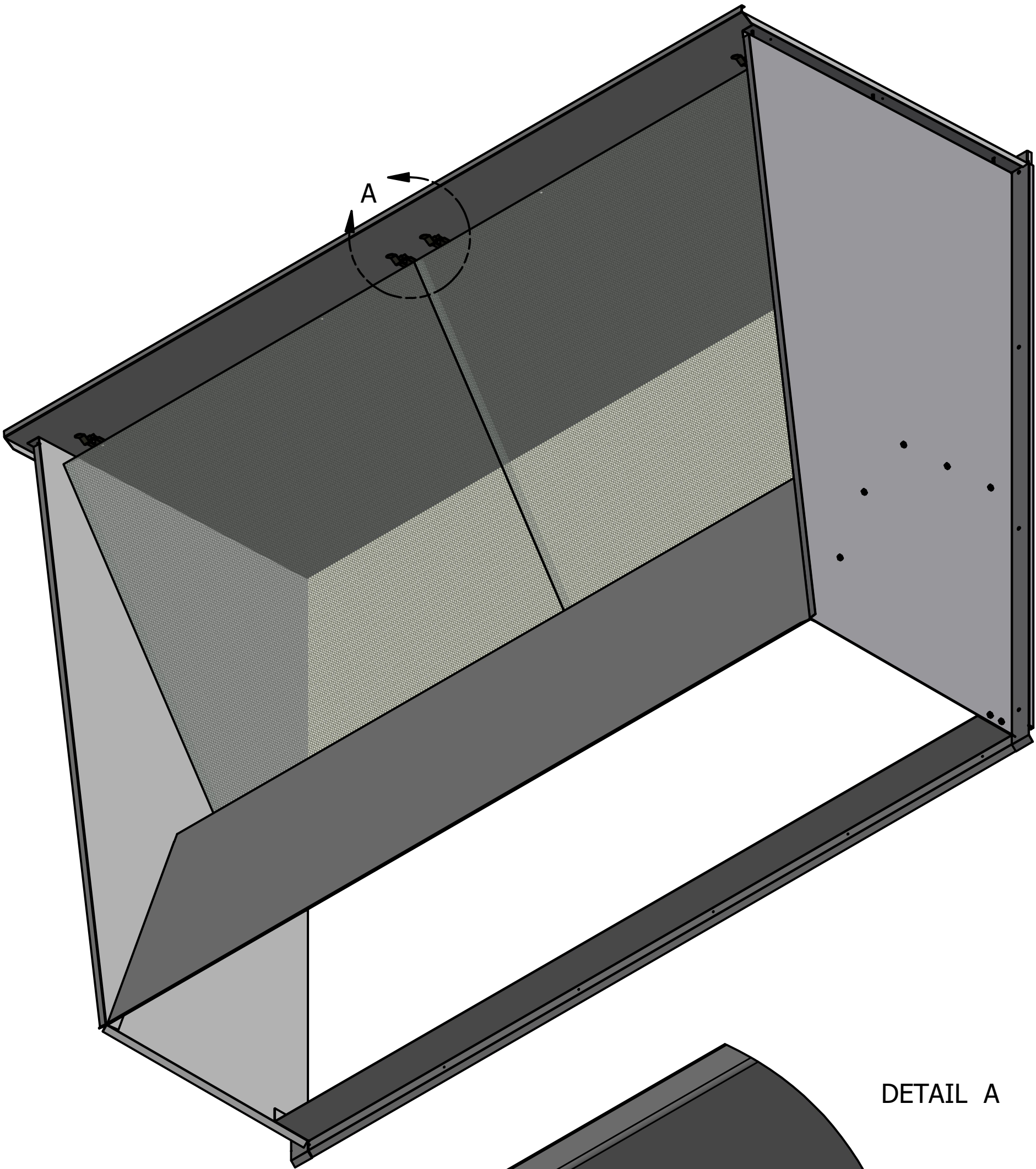

DETAIL A

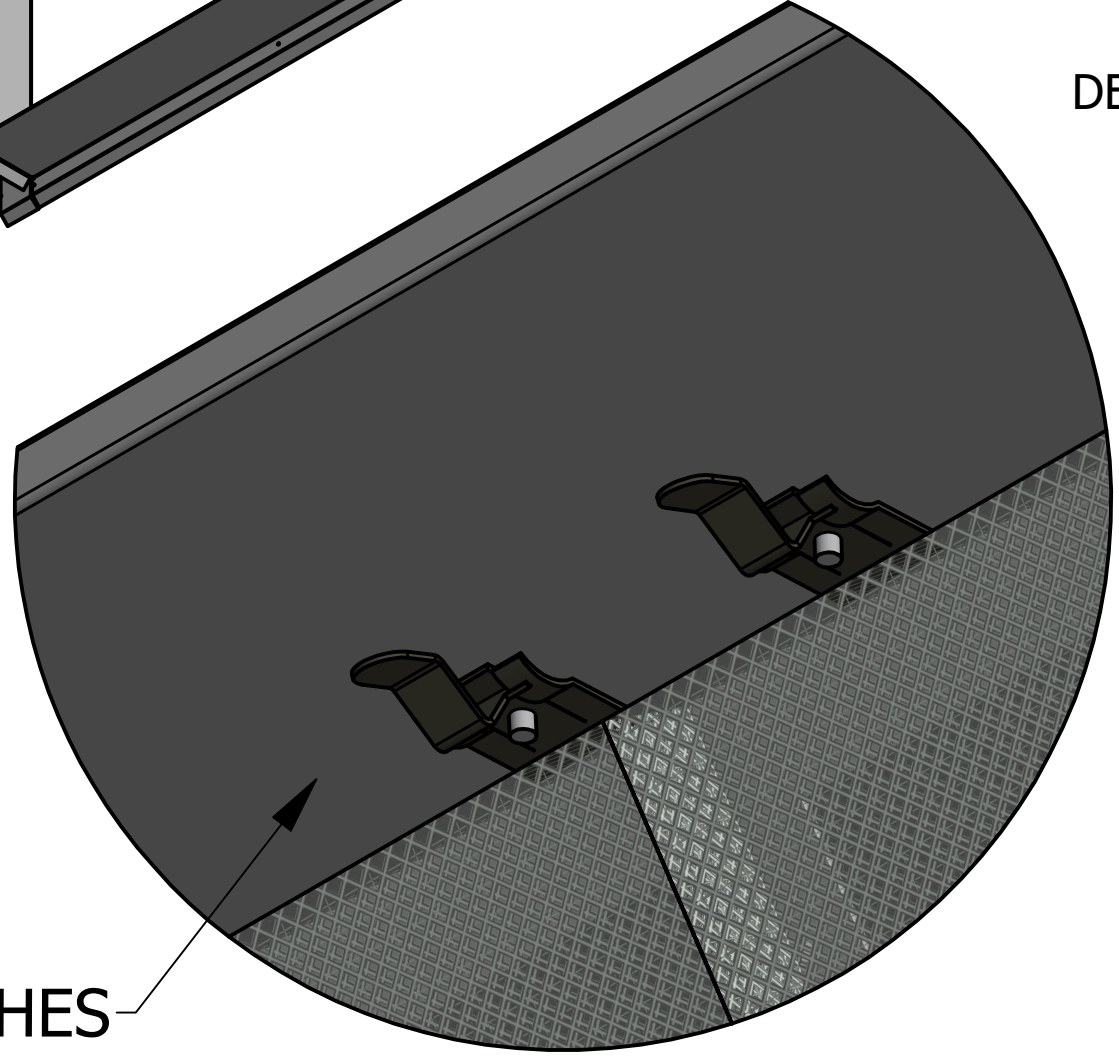

FLIP LATCHES
DOWN

