



ECONOMIZER 101

Economizers are designed to provide “free” air conditioning when outside conditions are appropriate. When the outside air is cool and enough, the economizer automatically opens to introduce the cool air to the interior space, thereby eliminating the need to run the air conditioning compressor.

If the outside air becomes too warm, the economizer automatically closes the fresh air damper and the compressor engages to begin cooling the space mechanically.

If a two stage thermostat is used it is possible to use a combination of economizer and mechanical cooling to condition the space.

The economizer can also be set to allow a minimum amount of fresh air to enter the space when the equipment’s indoor blower is operating.

Economizers are valuable tools to enhance indoor air quality, save energy and prolong the life of the air conditioning equipment.

SEQUENCE OF OPERATION

This sequence assumes employment of a dry bulb economizer using a two stage thermostat.

1. A call for cooling comes from room thermostat.
2. The dry bulb sensor determines if the atmospheric conditions are conducive for using outside air for cooling. If YES, go to step 3. If NO, or if outdoor air temperature rises above dry bulb set point, go to step 4.
3. The outside air dampers open and modulate to maintain a mixed air temperature (outside air + indoor air) of 53 degrees F. If the outdoor air is insufficient to satisfy the thermostat alone and a second stage of cooling is required, the first stage compressor starts and works in conjunction with the economizerto cool the space. (Go to step 5).

4. Outdoor air dampers open to minimum position and the compressor engages to provide mechanical cooling.
5. When the thermostat is satisfied the outside air dampers return to a closed position.

INSTALLATION

1. Open the containers and inspect the contents for shortages and damage.
2. Remove the large evaporator access panel from the package unit and discard. Remove the smaller filter access panel. **Retain screws for attaching economizer hood.**
3. Slide the base plate into the opening with the wider flange toward the outside of the unit and place it over the return air opening. It should be centered between the evaporator opening side posts. (Figure 1)
4. Slide the damper rack into the large opening until the front flange is against the evaporator support bracket. (Figure 2)

Figure 1



Figure 2

5. Slide the damper rack to the right until the damper side flanges are even with the evaporator access panel opening flange. The top flange of the damper rack should be even with or just inside the top cap of the unit. (Figure 3&4)

Warranty: Honeywell Jade components have 5 year parts warranty.
Workmanship and all other parts, 1 year parts only

MINIMUM SET POINT EQUATION

$$(To \times OA) + (Tr \times RA) = Tm$$

To = Outdoor air temperature

OA= Percent of outdoor air

Tr = Return air temperature

RA= Percent of return air

Tm= Resulting mixed air temperature

Example:

Fresh air required is 10% outdoor air.

Outdoor air temperature is 60 degrees F.

Return air temperature is 75 degrees F.

$$(0.1 \times 60) + (0.9 \times 75) =$$

$$6.0 + 67.5 = 73.5$$

Mixed air temperature will be 73.5 degrees F when the OA is 60 degrees F and the RA is 75 degrees F with 10% outdoor air.



Figure 3



Figure 4



Figure 5

6. Assemble the fresh air / barometric relief hood using the instructions in this document.
7. Install the hood assembly taking care to slide the top flange of the hood under the top cap of the unit.
8. Secure the hood with the screws from step 2.
9. Install the mist eliminators and secure them using the latches provided.
10. Locate the unit economizer 9 pin plug inside the evaporator section near the filter access opening and plug it into the corresponding 9 pin plug on the economizer.

NOTE: Ensure neither the wire nor the plugs interfere with the movement of the dampers during operation.

11. Remove the blower access panel on the unit and install the mixed air sensor on the blower housing toward the outside edge ensuring that the screws do not interfere with the blower wheel. (Figure 5)
12. Connect the pink mixed air sensor wire to the sensor and then feed the pink wire back to the Jade control and connect it on the MAT terminal.
13. Seal the hood using silicone or other approved method to ensure a water tight seal
14. Replace the blower and filter access panel.

CONTENTS

QTY	DESCRIPTION
1	DAMPER w/ECONOMIZER CONTROLS
1	BASE PLATE
1	C7250A1001 MIXED AIR SENSOR
1	JADE ECONOMIZER MANUAL
1	INSTALLATION INSTRUCTION

ACCESSORIES / CAPABILITIES

Demand Control Ventilation - Requires a CO2 sensor.

Power Exhaust - SPE180300X, 145-DK-14X or 146-DK-14X power exhausts are used in applications where barometric relief is not sufficient.

Important Notes

Please see enclosed brochure for Honeywell component trouble shooting and configuration instructions.

The fresh air mist eliminator should be flushed periodically with warm soapy water.

A two stage thermostat is recommended with this accessory.

HOOD SUB-ASSEMBLY INSTRUCTIONS

STEP 1: SCREW HOOD SIDES TO HOOD DIVIDER & HOOD BOTTOM, AS SHOWN

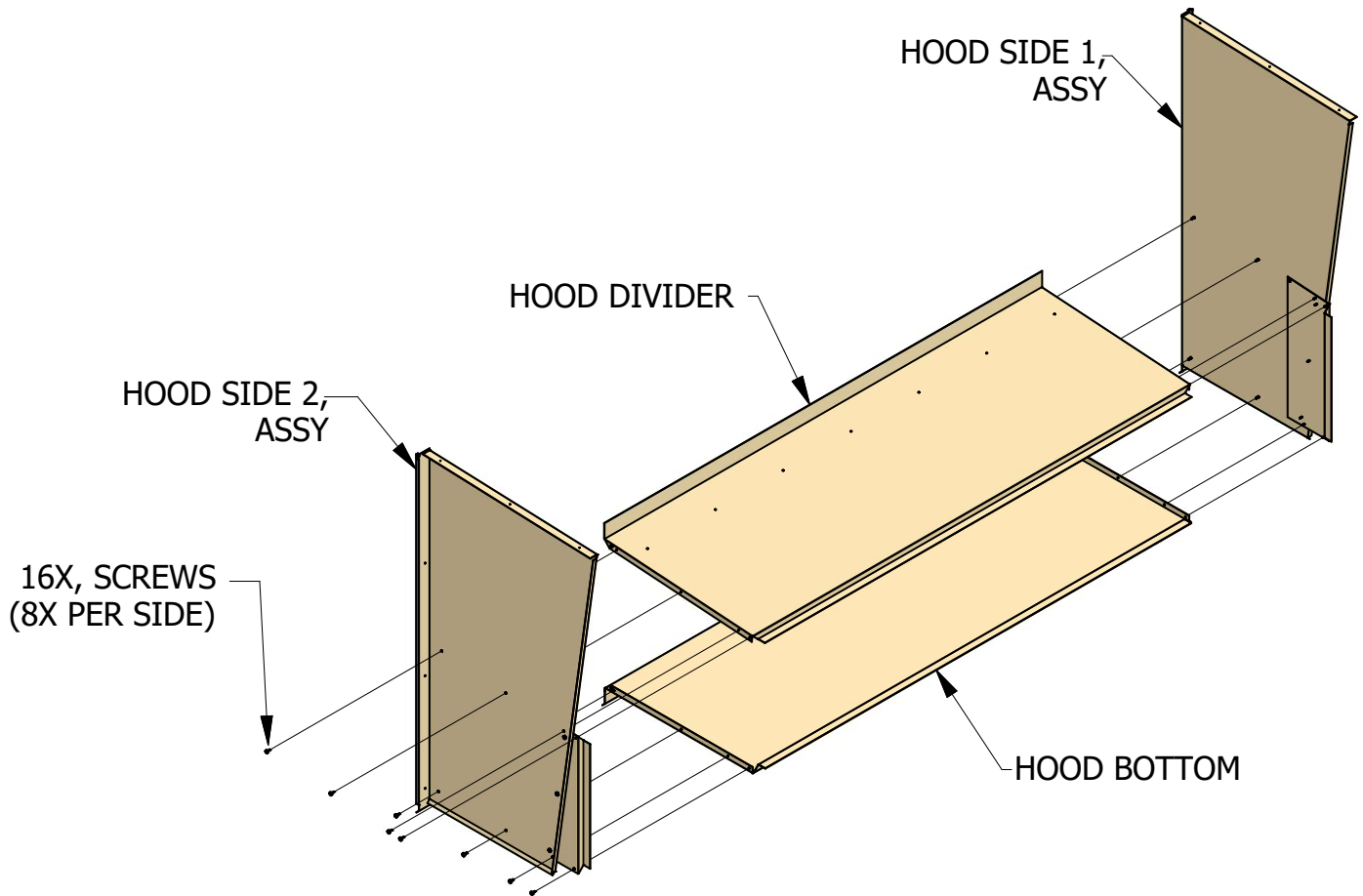

STEP 2: SCREW HOOD TOP TO BOTH HOOD SIDES, AS SHOWN

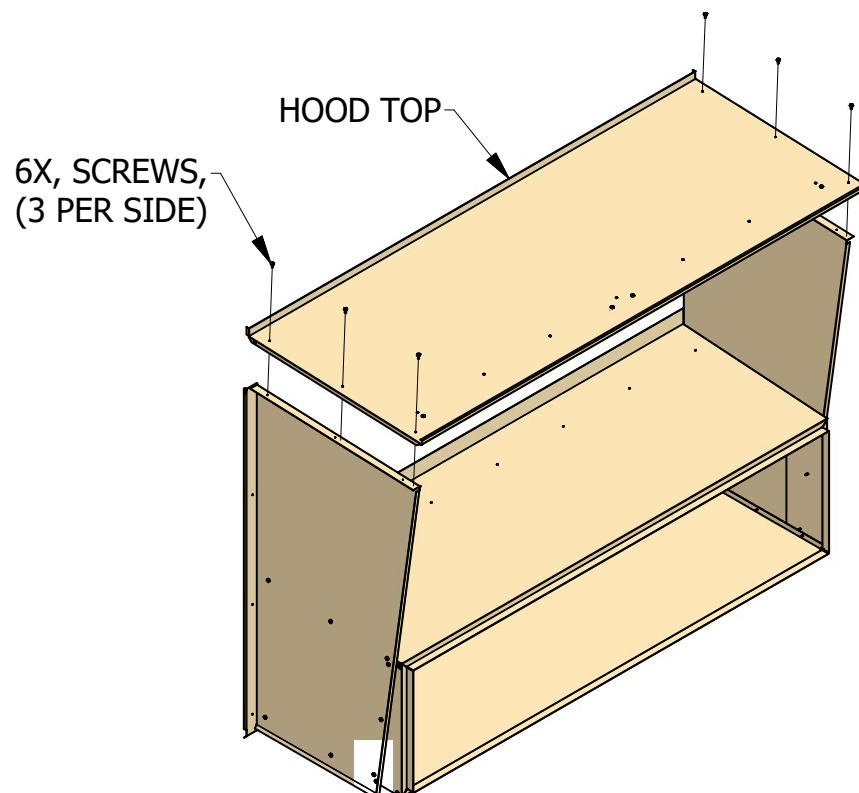

HOOD SUB-ASSEMBLY INSTRUCTIONS

STEP 3: ALIGN FILTER RACK HOLES WITH HOOD TOP & HOOD DIVIDER, & ATTACH AS SHOWN

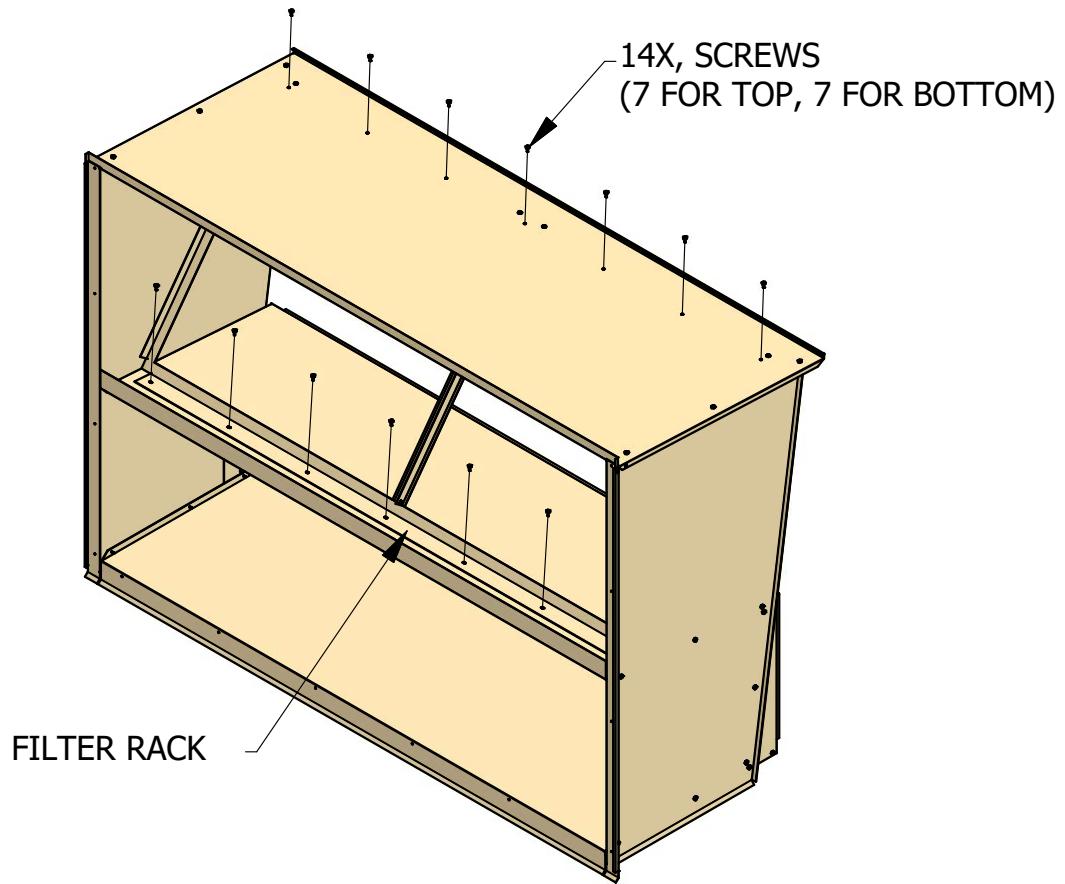

STEP 4: INSERT MIST ELIMINATOR FILTERS INTO FRESH AIR HOOD & RETAIN WITH FILTER LATCHES.

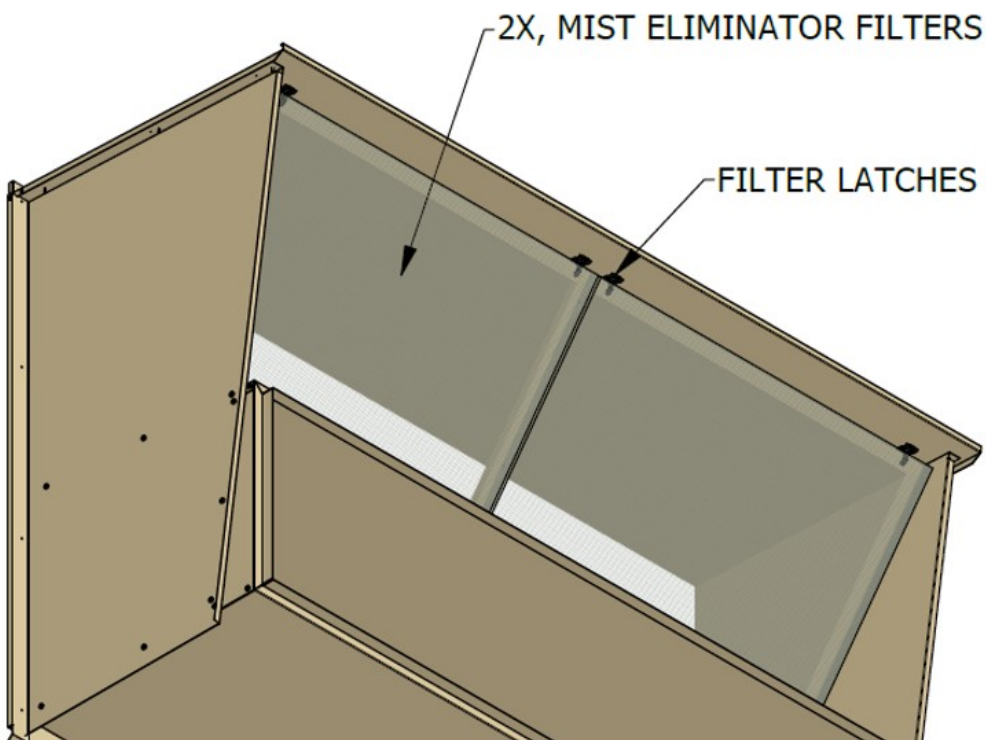

SHZECNDB180300B1AINT REV1

GROUND
GROUND LUG

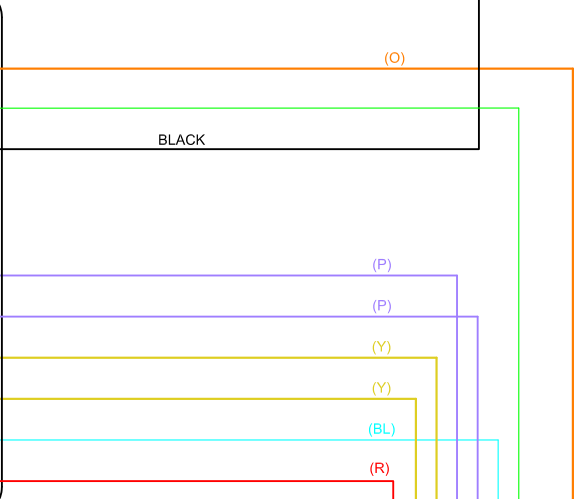
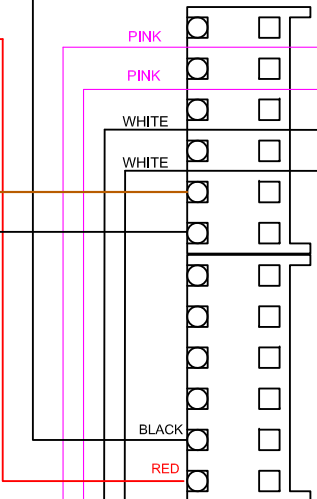
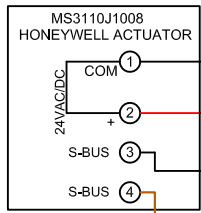

MOLEX 3597706**
50048926-002

- COLOR CODES FOR 9 PIN PLUG
- ① (Y) YELLOW
 - ② (P) PURPLE
 - ③ (P) PURPLE
 - ④ (Y) YELLOW
 - ⑤ (BL) BLUE
 - ⑥ (G) GREEN
 - ⑦ (O) ORANGE
 - ⑧ (R) RED
 - ⑨

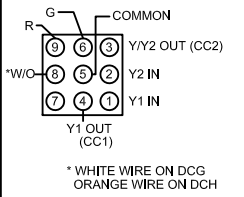

CONNECT TO
C7250A1001
MIXED AIR SENSOR

CONNECT TO
C7250A1001
DRY BULB SENSOR

