

**SPLIT SYSTEM HEAT PUMP****MODELS  
AIR HANDLING UNIT**

FTQ18TBVJUA  
 FTQ24TBVJUA  
 FTQ30TBVJUA  
 FTQ36TBVJUA  
 FTQ42TBVJUA  
 FTQ48TBVJUA

FTQ18TBVJUD  
 FTQ24TBVJUD  
 FTQ30TBVJUD  
 FTQ36TBVJUD  
 FTQ42TBVJUD  
 FTQ48TBVJUD

English

Français

Español

Read these instructions carefully before installation. Keep this manual in a handy place for future reference. This manual should be left with the equipment owner.

Lire soigneusement ces instructions avant l'installation. Conserver ce manuel à portée de main pour référence ultérieure. Ce manuel doit être donné au propriétaire de l'équipement.

Lea cuidadosamente estas instrucciones antes de instalar. Guarde este manual en un lugar a mano para leer en caso de tener alguna duda. Este manual debe permanecer con el propietario del equipo.

**WARNING****Do NOT BYPASS SAFETY DEVICES.****WARNING**

**ONLY PERSONNEL THAT HAVE BEEN TRAINED TO INSTALL, ADJUST, SERVICE, MAINTENANCE OR REPAIR (HEREINAFTER, "SERVICE") THE EQUIPMENT SPECIFIED IN THIS MANUAL SHOULD SERVICE THE EQUIPMENT.**

**THIS EQUIPMENT IS NOT INTENDED FOR USE BY PERSONS (INCLUDING CHILDREN) WITH REDUCED PHYSICAL, SENSORY OR MENTAL CAPABILITIES, OR LACK OF EXPERIENCE AND KNOWLEDGE, UNLESS THEY HAVE BEEN GIVEN SUPERVISION OR INSTRUCTION CONCERNING USE OF THE APPLIANCE BY A PERSON RESPONSIBLE FOR THEIR SAFETY.**

**CHILDREN SHOULD BE SUPERVISED TO ENSURE THAT THEY DO NOT PLAY WITH THE EQUIPMENT.**

**THE MANUFACTURER WILL NOT BE RESPONSIBLE FOR ANY INJURY OR PROPERTY DAMAGE ARISING FROM IMPROPER SUPERVISION, SERVICE OR SERVICE PROCEDURES. IF YOU SERVICE THIS UNIT, YOU ASSUME RESPONSIBILITY FOR ANY INJURY OR PROPERTY DAMAGE WHICH MAY RESULT. IN ADDITION, IN JURISDICTIONS THAT REQUIRE ONE OR MORE LICENSES TO SERVICE THE EQUIPMENT SPECIFIED IN THIS MANUAL, ONLY LICENSED PERSONNEL SHOULD SERVICE THE EQUIPMENT. IMPROPER SUPERVISION, INSTALLATION, ADJUSTMENT, SERVICING, MAINTENANCE OR REPAIR OF THE EQUIPMENT SPECIFIED IN THIS MANUAL, OR ATTEMPTING TO INSTALL, ADJUST, SERVICE OR REPAIR THE EQUIPMENT SPECIFIED IN THIS MANUAL WITHOUT PROPER SUPERVISION OR TRAINING MAY RESULT IN PRODUCT DAMAGE, PROPERTY DAMAGE, PERSONAL INJURY OR DEATH.**



## Table of Contents

SAFETY INSTRUCTIONS .....	2
BEFORE INSTALLATION .....	5
SELECTING INSTALLATION SITE .....	6
INSTALLATION LOCATION .....	6
REFRIGERANT PIPING WORK .....	11
DRAIN PIPING WORK.....	13
DUCT WORK .....	14
ELECTRICAL WIRING WORK .....	14
FIELD SETTINGS .....	18
ACCESSORIES.....	21
TEST RUN .....	22
WIRING DIAGRAM .....	23

## SAFETY INSTRUCTIONS

Read these *SAFETY INSTRUCTIONS* for Installation carefully before installing an air conditioner or heat pump. After completing the installation, make sure that the unit operates properly during the startup operation. Instruct the customer on how to operate and maintain the unit. Inform customers that they should store this Installation Manual with the Operation Manual for future reference.

Always use a licensed installer or contractor to install this product. Improper installation can result in water or refrigerant leakage, electrical shock, fire, or explosion.

This air conditioner comes under the term “appliances not accessible to the general public”.

**DANGER: REFRIGERANT GAS IS HEAVIER THAN AIR AND REPLACES OXYGEN. A MASSIVE LEAK CAN LEAD TO OXYGEN DEPLETION, ESPECIALLY IN BASEMENTS, AND AN ASPHYXIATION HAZARD COULD OCCUR LEADING TO SERIOUS INJURY OR DEATH. DO NOT GROUND UNITS TO WATER PIPES, GAS PIPES, TELEPHONE WIRES, OR LIGHTNING RODS AS INCOMPLETE GROUNDING CAN CAUSE A SEVERE SHOCK HAZARD RESULTING IN SEVERE INJURY OR DEATH. ADDITIONALLY, GROUNDING TO GAS PIPES COULD CAUSE A GAS LEAK AND POTENTIAL EXPLOSION CAUSING SEVERE INJURY OR DEATH.**

**DANGER: IF REFRIGERANT GAS LEAKS DURING INSTALLATION, VENTILATE THE AREA IMMEDIATELY. REFRIGERANT GAS MAY PRODUCE TOXIC GAS IF IT COMES IN CONTACT WITH FIRE. EXPOSURE TO THIS GAS COULD CAUSE SEVERE INJURY OR DEATH.**

**DANGER: AFTER COMPLETING THE INSTALLATION WORK, CHECK THAT THE REFRIGERANT GAS DOES NOT LEAK THROUGHOUT THE SYSTEM.**

**DANGER: DO NOT INSTALL UNIT IN AN AREA WHERE FLAMMABLE MATERIALS ARE PRESENT DUE TO RISK OF EXPLOSIONS THAT CAN CAUSE SERIOUS INJURY OR DEATH.**

**DANGER: SAFELY DISPOSE ALL PACKING AND TRANSPORTATION MATERIALS IN ACCORDANCE WITH FEDERAL/STATE/LOCAL LAWS OR ORDINANCES. PACKING MATERIALS SUCH AS NAILS AND OTHER METAL OR WOOD PARTS, INCLUDING PLASTIC PACKING MATERIALS USED FOR TRANSPORTATION MAY CAUSE INJURIES OR DEATH BY SUFFOCATION.**



### WARNING

**ALL PHASES OF THE FIELD-INSTALLATION, INCLUDING, BUT NOT LIMITED TO, ELECTRICAL, PIPING, SAFETY, ETC. MUST BE IN ACCORDANCE WITH MANUFACTURER’S INSTRUCTIONS AND MUST COMPLY WITH NATIONAL, STATE, PROVINCIAL AND LOCAL CODES.**



### WARNING

**ONLY QUALIFIED PERSONNEL MUST CARRY OUT THE INSTALLATION WORK. INSTALLATION MUST BE DONE IN ACCORDANCE WITH THIS INSTALLATION MANUAL. IMPROPER INSTALLATION MAY RESULT IN WATER LEAKAGE, ELECTRIC SHOCK, OR FIRE.**



### WARNING

**ONLY QUALIFIED PERSONNEL MUST CARRY OUT THE INSTALLATION WORK. INSTALLATION MUST BE DONE IN ACCORDANCE WITH THIS INSTALLATION MANUAL. IMPROPER INSTALLATION MAY RESULT IN WATER LEAKAGE, ELECTRIC SHOCK, OR FIRE.**



### WARNING

**ONLY QUALIFIED PERSONNEL MUST CARRY OUT THE INSTALLATION WORK. INSTALLATION MUST BE DONE IN ACCORDANCE WITH THIS INSTALLATION MANUAL. IMPROPER INSTALLATION MAY RESULT IN WATER LEAKAGE, ELECTRIC SHOCK, OR FIRE.**



### WARNING

**WHEN INSTALLING THE UNIT IN A SMALL ROOM, TAKE MEASURES TO KEEP THE REFRIGERANT CONCENTRATION FROM EXCEEDING ALLOWABLE SAFETY LIMITS. EXCESSIVE REFRIGERANT LEAKS, IN THE EVENT OF AN ACCIDENT IN A CLOSED AMBIENT SPACE, CAN LEAD TO OXYGEN DEFICIENCY.**



### WARNING

**USE ONLY SPECIFIED ACCESSORIES AND PARTS FOR INSTALLATION WORK. FAILURE TO USE SPECIFIED PARTS MAY RESULT IN WATER LEAKAGE, ELECTRIC SHOCKS, FIRE, OR THE UNIT FALLING.**



**WARNING**

**INSTALL THE AIR CONDITIONER OR HEAT PUMP ON A FOUNDATION STRONG ENOUGH THAT IT CAN WITHSTAND THE WEIGHT OF THE UNIT. A FOUNDATION OF INSUFFICIENT STRENGTH MAY RESULT IN THE UNIT FALLING AND CAUSING INJURIES.**



**WARNING**

**TAKE INTO ACCOUNT STRONG WINDS, TYPHOONS, OR EARTHQUAKES WHEN INSTALLING. IMPROPER INSTALLATION MAY RESULT IN THE UNIT FALLING AND CAUSING ACCIDENTS.**



**WARNING**

**MAKE SURE THAT A SEPARATE POWER SUPPLY CIRCUIT IS PROVIDED FOR THIS UNIT AND THAT ALL ELECTRICAL WORK IS CARRIED OUT BY QUALIFIED PERSONNEL ACCORDING TO LOCAL, STATE, AND NATIONAL REGULATIONS. AN INSUFFICIENT POWER SUPPLY CAPACITY OR IMPROPER ELECTRICAL CONSTRUCTION MAY LEAD TO ELECTRIC SHOCKS OR FIRE.**



**WARNING**

**WHEN WIRING, POSITION THE WIRES SO THAT THE ACCESS PANEL CAN BE SECURELY FASTENED. IMPROPER POSITIONING OF THE ACCESS PANEL MAY RESULT IN ELECTRIC SHOCKS, FIRE, OR THE TERMINALS OVERHEATING.**



**WARNING**

**BEFORE TOUCHING ELECTRICAL PARTS, TURN OFF THE UNIT.**



**WARNING**

**THIS EQUIPMENT CAN BE INSTALLED WITH A GROUND-FAULT CIRCUIT BREAKER (GFCI). ALTHOUGH THIS IS A RECOGNIZED MEASURE FOR ADDITIONAL PROTECTION, WITH THE GROUNDING SYSTEM IN NORTH AMERICA, A DEDICATED GFCI IS NOT REQUIRED.**



**WARNING**

**SECURELY FASTEN THE OUTSIDE UNIT TERMINAL COVER (PANEL). IF THE TERMINAL COVER/PANEL IS NOT INSTALLED PROPERLY, DUST OR WATER MAY ENTER THE OUTSIDE UNIT CAUSING FIRE OR ELECTRIC SHOCK.**



**WARNING**

**WHEN INSTALLING OR RELOCATING THE SYSTEM, KEEP THE REFRIGERANT CIRCUIT FREE FROM SUBSTANCES OTHER THAN THE SPECIFIED REFRIGERANT (R-410A) SUCH AS AIR. ANY PRESENCE OF AIR OR OTHER FOREIGN SUBSTANCE IN THE REFRIGERANT CIRCUIT CAN CAUSE AN ABNORMAL PRESSURE RISE OR RUPTURE, RESULTING IN INJURY.**



**WARNING**

**HEAT EXCHANGER FINS ARE SHARP ENOUGH TO CUT. TO AVOID INJURY WEAR GLOVES OR COVER THE FINS WHEN WORKING AROUND THEM.**



**WARNING**

**DO NOT CHANGE THE SETTING OF THE PROTECTION DEVICES. IF THE PRESSURE SWITCH, THERMAL SWITCH, OR OTHER PROTECTION DEVICE IS SHORTED AND OPERATED FORCIBLY, OR PARTS OTHER THAN THOSE SPECIFIED BY THE MANUFACTURER ARE USED, FIRE OR EXPLOSION MAY OCCUR.**



**CAUTION**

**DO NOT TOUCH THE SWITCH WITH WET FINGERS. TOUCHING SWITCH WITH WET FINGERS CAN CAUSE ELECTRIC SHOCK.**



**CAUTION**

**THE APPLIANCE INCORPORATES AN EARTHING CONNECTION FOR FUNCTIONAL PURPOSES ONLY.**



**CAUTION**

**DO NOT ALLOW CHILDREN TO PLAY ON OR AROUND THE UNIT TO PREVENT INJURY.**



**CAUTION**

**DO NOT TOUCH THE REFRIGERANT PIPES DURING AND IMMEDIATELY AFTER OPERATION AS THE REFRIGERANT PIPES MAY BE HOT OR COLD, DEPENDING ON THE CONDITION OF THE REFRIGERANT FLOWING THROUGH THE REFRIGERANT PIPING, COMPRESSOR, AND OTHER REFRIGERANT CYCLE PARTS. YOUR HANDS MAY SUFFER BURNS OR FROSTBITE IF YOU TOUCH THE REFRIGERANT PIPES. TO AVOID INJURY, GIVE THE PIPES TIME TO RETURN TO NORMAL TEMPERATURE OR, IF YOU MUST TOUCH THEM, BE SURE TO WEAR PROPER GLOVES.**



**CAUTION**

**INSTALL DRAIN PIPING TO PROPER DRAINAGE. IMPROPER DRAIN PIPING MAY RESULT IN WATER LEAKAGE AND PROPERTY DAMAGE.**



**CAUTION**

**INSULATE PIPING TO PREVENT CONDENSATION.**

**CAUTION**

BE CAREFUL WHEN TRANSPORTING THE PRODUCT.

**CAUTION**

DO NOT TURN OFF THE POWER IMMEDIATELY AFTER STOPPING OPERATION. ALWAYS WAIT FOR AT LEAST 5 MINUTES BEFORE TURNING OFF THE POWER. OTHERWISE, WATER LEAKAGE MAY OCCUR.

**CAUTION**

DO NOT TOUCH THE REFRIGERANT PIPES DURING AND IMMEDIATELY AFTER OPERATION AS THE REFRIGERANT PIPES MAY BE HOT OR COLD, DEPENDING ON THE CONDITION OF THE REFRIGERANT FLOWING THROUGH THE REFRIGERANT PIPING, COMPRESSOR, AND OTHER REFRIGERANT CYCLE PARTS. YOUR HANDS MAY SUFFER BURNS OR FROSTBITE IF YOU TOUCH THE REFRIGERANT PIPES. TO AVOID INJURY, GIVE THE PIPES TIME TO RETURN TO NORMAL TEMPERATURE OR, IF YOU MUST TOUCH THEM, BE SURE TO WEAR PROPER GLOVES.

**CAUTION**

DO NOT USE A CHARGING CYLINDER. USING A CHARGING CYLINDER MAY CAUSE THE REFRIGERANT TO DETERIORATE.

**CAUTION**

REFRIGERANT R-410A IN THE SYSTEM MUST BE KEPT CLEAN, DRY, AND TIGHT.

- CLEAN AND DRY — FOREIGN MATERIALS (INCLUDING MINERAL OILS SUCH AS SUNISO OIL OR MOISTURE) SHOULD BE PREVENTED FROM GETTING INTO THE SYSTEM.
- TIGHT — R-410A DOES NOT CONTAIN ANY CHLORINE, DOES NOT DESTROY THE OZONE LAYER, AND DOES NOT REDUCE THE EARTH'S PROTECTION AGAIN HARMFUL ULTRAVIOLET RADIATION. R-410A CAN CONTRIBUTE TO THE GREENHOUSE EFFECT IF IT IS RELEASED. THEREFORE TAKE PROPER MEASURES TO CHECK FOR THE TIGHTNESS OF THE REFRIGERANT PIPING INSTALLATION. READ THE CHAPTER REFRIGERANT PIPING AND FOLLOW THE PROCEDURES.

**CAUTION**

SINCE R-410A IS A BLEND, THE REQUIRED ADDITIONAL REFRIGERANT MUST BE CHARGED IN ITS LIQUID STATE. IF THE REFRIGERANT IS CHARGED IN A STATE OF GAS, ITS COMPOSITION CAN CHANGE AND THE SYSTEM WILL NOT WORK PROPERLY. THE INDOOR UNIT IS FOR R-410A. SEE THE CATALOG FOR INDOOR MODELS THAT CAN BE CONNECTED. NORMAL OPERATION IS NOT POSSIBLE WHEN CONNECTED TO OTHER UNITS.

**CAUTION**

REMOTE CONTROLLER (WIRELESS KIT) TRANSMITTING DISTANCE CAN BE SHORTER THAN EXPECTED IN ROOMS WITH ELECTRONIC FLUORESCENT LAMPS (INVERTER OR RAPID START TYPES). INSTALL THE INDOOR UNIT FAR AWAY FROM FLUORESCENT LAMPS AS MUCH AS POSSIBLE.

**CAUTION**

INDOOR UNITS ARE FOR INDOOR INSTALLATION ONLY. OUTDOOR UNITS CAN BE INSTALLED EITHER OUTDOORS OR INDOORS. THIS UNIT IS FOR INDOOR USE.

**CAUTION**

DO NOT INSTALL THE AIR CONDITIONER OR HEAT PUMP IN THE FOLLOWING LOCATIONS:

- WHERE A MINERAL OIL MIST OR OIL SPRAY OR VAPOR IS PRODUCED, FOR EXAMPLE, IN A KITCHEN.
- PLASTIC PARTS MAY DETERIORATE AND FALL OFF OR RESULT IN WATER LEAKAGE.
- WHERE CORROSIVE GAS, SUCH AS SULFUROUS ACID GAS, IS PRODUCED. CORRODING COPPER PIPES OR SOLDERED PARTS MAY RESULT IN REFRIGERANT LEAKAGE.
- NEAR MACHINERY EMITTING ELECTROMAGNETIC WAVES. ELECTROMAGNETIC WAVES MAY DISTURB THE OPERATION OF THE CONTROL SYSTEM AND CAUSE THE UNIT TO MALFUNCTION.
- WHERE FLAMMABLE GAS MAY LEAK, WHERE THERE IS CARBON FIBER, OR IGNITABLE DUST SUSPENSION IN THE AIR, OR WHERE VOLATILE FLAMMABLES SUCH AS THINNER OR GASOLINE ARE HANDLED. OPERATING THE UNIT IN SUCH CONDITIONS CAN CAUSE A FIRE.

**CAUTION**

TAKE ADEQUATE MEASURES TO PREVENT THE OUTSIDE UNIT FROM BEING USED AS A SHELTER BY SMALL ANIMALS. SMALL ANIMALS MAKING CONTACT WITH ELECTRICAL PARTS CAN CAUSE MALFUNCTIONS, SMOKE, OR FIRE. INSTRUCT THE CUSTOMER TO KEEP THE AREA AROUND THE UNIT CLEAN.

**NOTE: INSTALL THE POWER SUPPLY AND CONTROL WIRES FOR THE INDOOR AND OUTDOOR UNITS AT LEAST 3.5 FEET AWAY FROM TELEVISIONS OR RADIOS TO PREVENT IMAGE INTERFERENCE OR NOISE. DEPENDING ON THE RADIO WAVES, A DISTANCE OF 3.5 FEET MAY NOT BE SUFFICIENT TO ELIMINATE THE NOISE.**

**NOTE: DISMANTLING THE UNIT, TREATMENT OF THE REFRIGERANT, OIL AND ADDITIONAL PARTS MUST BE DONE IN ACCORDANCE WITH THE RELEVANT LOCAL, STATE, AND NATIONAL REGULATIONS.**

**NOTE: DO NOT USE THE FOLLOWING TOOLS THAT ARE USED WITH CONVENTIONAL REFRIGERANTS: GAUGE MANIFOLD, CHARGE HOSE, GAS LEAK DETECTOR, REVERSE FLOW CHECK VALVE, REFRIGERANT CHARGE BASE, VACUUM GAUGE, OR REFRIGERANT RECOVERY EQUIPMENT.**

**NOTE: IF THE CONVENTIONAL REFRIGERANT AND REFRIGERATOR OIL ARE MIXED IN R-410A, THE REFRIGERANT MAY DETERIORATE.**

**NOTE: THIS AIR CONDITIONER OR HEAT PUMP IS AN APPLIANCE THAT SHOULD NOT BE ACCESSIBLE TO THE GENERAL PUBLIC.**

## BEFORE INSTALLATION

 <b>WARNING</b>
<b>ENTRUST INSTALLATION TO THE PLACE OF PURCHASE OR A QUALIFIED SERVICEMAN. IMPROPER INSTALLATION COULD LEAD TO LEAKS AND, IN WORSE CASES, ELECTRIC SHOCK OR FIRE.</b>

 <b>WARNING</b>
<b>USE OF UNSPECIFIED PARTS COULD LEAD TO THE UNIT FAILING, LEAKS AND, IN WORSE CASES, ELECTRIC SHOCK OR FIRE.</b>

**NOTE: BE SURE TO READ THIS MANUAL BEFORE INSTALLING THE INDOOR UNIT.**

**NOTE: BE SURE TO MOUNT AN AIR FILTER (PART TO BE PROCURED IN THE FIELD) IN THE SUCTION AIR PASSAGE IN ORDER TO PREVENT WATER LEAKING, ETC.**

**NOTE: THIS UNIT IS A PARTIAL UNIT AIR CONDITIONER, COMPLYING WITH PARTIAL UNIT REQUIREMENTS OF THIS INTERNATIONAL STANDARD, AND MUST BE ONLY CONNECTED TO OTHER UNITS THAT HAVE BEEN CONFIRMED AS COMPLYING TO CORRESPONDING PARTIAL UNIT REQUIREMENTS OF THIS INTERNATIONAL STANDARD.**

The accessories needed for installation must be retained in your custody until the installation work is completed. Do not discard them.

1. Decide upon a line of transport.
2. Leave the unit inside its packaging while moving, until reaching the installation site. Where unpacking is unavoidable, use a sling of soft material or protective plates together with a rope when lifting, to avoid damage or scratches to the unit.

Be sure to check the type of R-410A refrigerant to be used before installing the unit. (Using an incorrect refrigerant will prevent normal operation of the unit.) For the installation of an outdoor unit, refer to the installation manual attached to the outdoor unit.

### PRECAUTIONS

- Be sure to instruct customers how to properly operate the unit (operating different functions, and adjusting the temperature) by having them carry out operations themselves while looking at the operation manual.

- Do not install in locations where the air contains high levels of salt such as that near the ocean and where voltage fluctuates greatly such as that in factories, or in vehicles or vessels.

### OPTIONAL ACCESSORIES

This indoor unit requires one of the operation remote controls listed below.

Remote Controller	
Wired type	BRC1E73, BRC1H71W, DTST-ONE-ADA-A

For the following items, take special care during construction and check after installation is finished.

### Items to be checked after completion of work:

Items to be checked	If not properly done, what is likely to occur	Check
Are the indoor and outdoor units fixed firmly?	If units may drop,vibrate or make noise	
Was the installation of the outdoor unit completed?	The unit may malfunction or the components burn out.	
Is the refrigerant leak test finished?	It may result in insufficient cooling.	
Is the unit fully insulated?	Condensate may drip.	
Does the drainage flow smoothly?	Condensate may drip.	
Does the power supply voltage correspond to that shown on the name plate?	The unit may malfunction or the components burn out.	
Are the wiring and piping correct?	The unit may malfunction or the components burn out.	
Is the air conditioner or heat pump properly grounded?	Dangerous in case of current leakage.	
Is the unit safely grounded?	Incomplete grounding may result in electric shocks.	
Is wiring size according to specifications?	The unit may malfunction or the components burn out.	
Is something blocking the air outlet or inlet of either the indoor or outdoor units?	It may result in insufficient cooling.	
Did you set the external static pressure?	No cooling or heating.	
Are the refrigerant piping length and additional refrigerant charge noted down?	The refrigerant change in the system is not clear.	
Did you check that no wiring connection screws were loose?	Electric shock or fire.	

Also review the *SAFETY CONSIDERATIONS*.

**Items to be checked at time of delivery:**

Items to be checked	Check
Did you hand the operation manual and warranty over to your customer?	
Did you explain about operations while showing the operation manual to your customer?	
Did you explain to your customer how to maintain and clean local procurements such as the air filter, suction grille, and air outlet grille?	
Did you hand manuals of local procurements (in case equipped) over to your customer?	

**SELECTING INSTALLATION SITE**

 <b>CAUTION</b>
<p><b>IN CASES WHERE THE UNIT IS INSTALLED IN A SPACE WHERE THE HUMIDITY MIGHT EXCEED 86°F AND RH80%, REINFORCE THE INSULATION ON THE UNIT BODY.</b></p>

 <b>CAUTION</b>
<p><b>USE GLASS WOOL OR POLYETHYLENE FOAM AS INSULATION SO THAT THE THICKNESS IS MORE THAN 2" AND FITS INSIDE THE INSTALLATION SPACE OPENING.</b></p>

Select an installation site where the following conditions are fulfilled and meets with your customer's approval.

- Where optimum air distribution can be ensured.
- Where nothing blocks air passage.
- Where condensate can be properly drained.
- Where the supports are strong enough to bear the indoor unit weight.
- Where the false ceiling is not noticeably on an incline.
- Where piping between indoor and outdoor units is possible within the allowable limit. (Refer to the installation manual for the outdoor unit.)
- If a return-air duct is not installed, carefully select the place and method of product installation so that air flow into the product will not be blocked.
- The unit clearance from a combustible surface may be 0". However, service clearance must take precedence. A minimum of 24" in front of the unit for service clearance is required. Additional clearance on one side or top will be required for electrical wiring connections. Consult all appropriate regulatory codes prior to determining final clearances. When installing this unit in an area that may become wet (such as crawl spaces), elevate the unit with a sturdy, non-porous material. In installations that may lead to physical damage (i.e. a garage) it is advised to install

a protective barrier to prevent such damage. Always install units such that a positive slope in condensate line (1/4" per foot) is allowed.

If installed horizontally above a finished living space a secondary drain pan, as required by many building codes, must be installed under the entire unit and its condensate drain line must be routed to a location such that the user will see the condensate discharge.

**INSTALLATION LOCATION**

**NOTE: THESE AIR HANDLERS ARE DESIGNED FOR INDOOR INSTALLATION ONLY AT A MAX ALTITUDE OF 10,500 FEET ABOVE SEA LEVEL OR A MIN ALTITUDE OF -184 FEET BELOW SEA LEVEL.**

Applications where the air handler is installed and the return air environment see humidity levels above 65% relative humidity coupled with total external static levels above 0.5"; it is recommended to reinforce the insulation on the unit body.

The FTQ\*\*T product line may be installed in one of the upflow, downflow, horizontal left or horizontal right orientations as shown in Figures 3, 4, 5 and 6. The unit may be installed in upflow or horizontal left orientation as shipped (refer to specific sections for more information). Minor field modifications are necessary to convert to downflow or horizontal right as indicated in below sections.

**NOTE: WHEN INSTALLING THE AIR HANDLER IN THE HORIZONTAL RIGHT POSITION IN HIGH TEMPERATURE/HIGH HUMIDITY CONDITIONS IT IS RECOMMENDED TO RELOCATE THE PCB 90 DEGREES AND ATTACH TO BLOWER DECK OR TOP PLATE IF HEAT KIT IS INSTALLED. See instructions below to relocate the PCB.**

1. Remove the mounting screws on the side of the PCB and the screw on the bottom side attaching bracket to the blower deck. (Figure 1.) **NOTE:** Remove top plate for easier access to screw behind board.



Figure 1.

- Cut the wire tie to allow excess wire to rotate the PCB. (Figure 2.)



Figure 2.

- Rotate 90 degrees and attach to blower deck. Using two self-tapping screws. (Figure 3.)

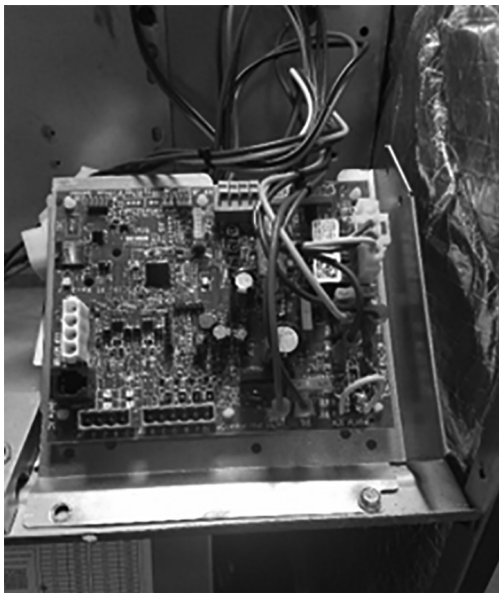

Figure 3.

- Bundle excess wire using wire tie.
- Make sure to check all wing connections are secure and tight.

AVPTC with heat kit installed or AVPEC air handler.

- Follow steps 1 and 2 above.
- Rotate 90 degrees up and attach to top plate. Using two self-tapping screws.



Figure 4.

- Bundle excess wire using wire tie.
- Make sure to check all wing connections are secure and tight.

**NOTE: CONDENSATION MAY FORM ON THE PRODUCT DURING COOL OPERATION. IT IS RECOMMENDED TO INSTALL SECONDARY DRAIN PAN (FIELD SUPPLIED).**

#### UPFLOW INSTALLATION

No field modifications are mandatory however to obtain maximum efficiency, the horizontal drip shield, side drain pan and drain pan extension, can be removed.

**Side Drain Pan and Extension Removal:** Refer to Figure 1; remove the two (2) screws that secure the drip shield support brackets to the horizontal drip shield (front and back). Unsnap the side drain pan from the bottom drain pan using a screw driver or any small lever. The side drain pan, drip shield brackets and the drain pan extension may now be removed. From Figure 1, drain port labeled (A) is the primary drain for this application and condensate drain line must be attached to this drain port. Drain port (a) is for the secondary drain line (if used).

#### HORIZONTAL LEFT INSTALLATION

**No field modifications are permissible for this application.**

Refer to Figure 7 and 8 for the location of the components referenced in the following steps.

Drain port labeled (B) in Figure 1 is the primary drain for this application and condensate drain line must be attached to this drain port. Drain port (b) is for the secondary drain line (if used).

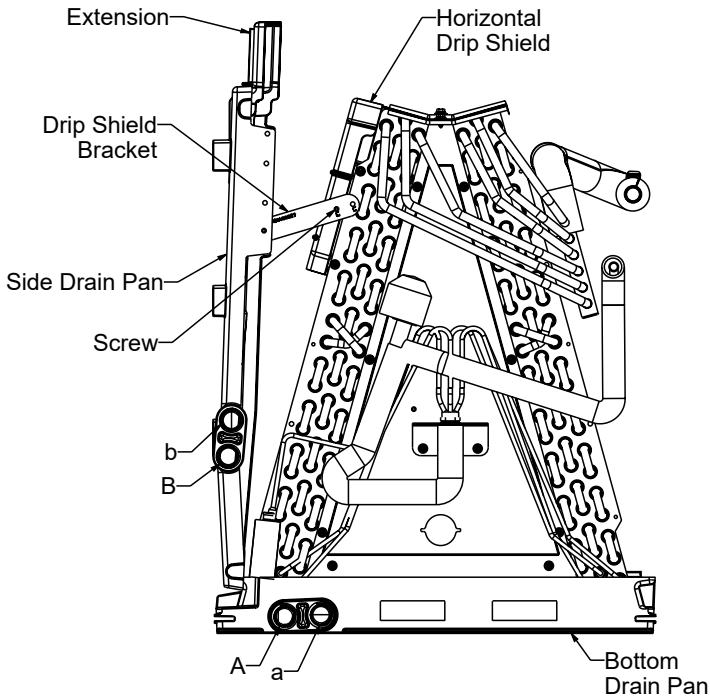

Figure 1

**DOWNFLOW/HORIZONTAL RIGHT INSTALLATION**

**IMPORTANT NOTE:** In the downflow application, to prevent coil pan “sweating”, a downflow kit (DFK) is available through your local Daikin distributor. The DFK is not supplied with the air handler and is required to minimize pan sweating on all downflow installations. See Table 1 for the correct DFK and follow the instructions provided for installation.

DFK-B Downflow Kit	DFK-C Downflow Kit
FTQ18TBVJUA	FTQ42TBVJUA
FTQ18TBVJUD	FTQ42TBVJUD
FTQ24TBVJUA	FTQ48TBVJUA
FTQ24TBVJUD	FTQ48TBVJUD
FTQ30TBVJUA	
FTQ30TBVJUD	
FTQ36TBVJUA	
FTQ36TBVJUD	

**DOWNFLOW KIT**

Table 1

2. Before removing the coil remove the wire ties holding the sensor wire harness to the center support. Remove the insulation covering the wire connectors and disconnect the wires. Do not cut or damage the insulation covering the junction connectors since it will be required to secure the wires once the change is complete. See Figures 2-1 and 2-2 for wire tie location.

**NOTE: DO NOT USE MANIFOLDS OR FLOWRATOR TO PULL THE COIL ASSEMBLY OUT. FAILURE TO DO SO MAY RESULT IN BRAZE JOINT DAMAGE AND LEAKS.**

3. Slide the coil assembly out using the bottom drain pan to pull the assembly from the cabinet.
4. For flipping the coil, drain pan extension must be removed for all models. Center support should not be removed while removing the drain pan extension. Side drain pan and horizontal drip shield can be removed for downflow application. The side drain pan and horizontal drip shield cannot be removed for horizontal right.
5. Using the bottom drain pan to hold the coil assembly, slide the coil assembly back into the cabinet on the downflow brackets as shown in Figure 9.
6. Reconnect the sensor wires and replace the insulation securing it with wire ties on both sides as shown in Figure 2-2. Then, secure the wire harness to the corner post using the screw mount wire ties provided.
7. Re-install the access panels removed in Step 1.
8. Two drain ports located at the bottom drain pan (horizontally oriented) are to be used for upflow and downflow applications and the two on the side drain pan (vertically oriented) are to be used when the unit is in horizontal right or left configuration. When the unit is in upflow or downflow configuration, the drain ports located on bottom drain pan must be plugged and vice versa. Drain ports located at lower elevation (closer to the ground) in either configuration must be connected to the main drain line and the higher is for the secondary drain line.

1. Before flipping the air handler, remove blower access panel and coil access panel. The coil access panel and tubing panel may remain screwed together during this procedure. Remove and retain the seven (7) screws securing the coil access panel to the cabinet and the six (6) screws securing the blower access panel to the cabinet.

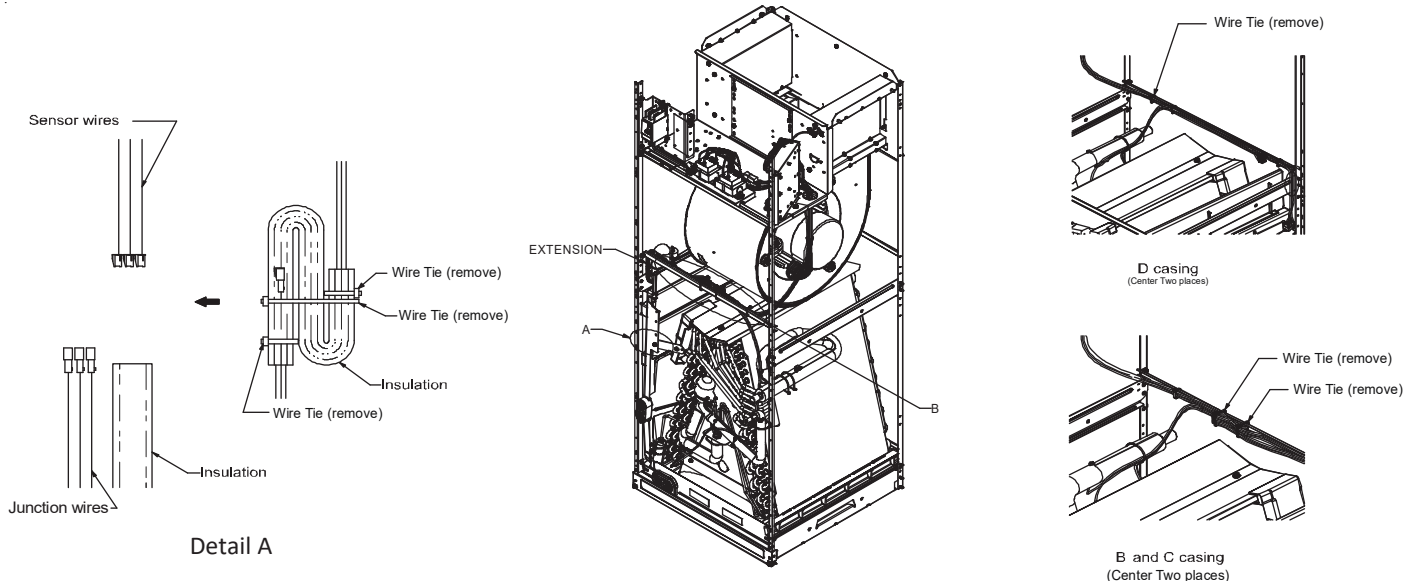

WIRE TIE LOCATION TO BE REMOVED

Figure 2-1

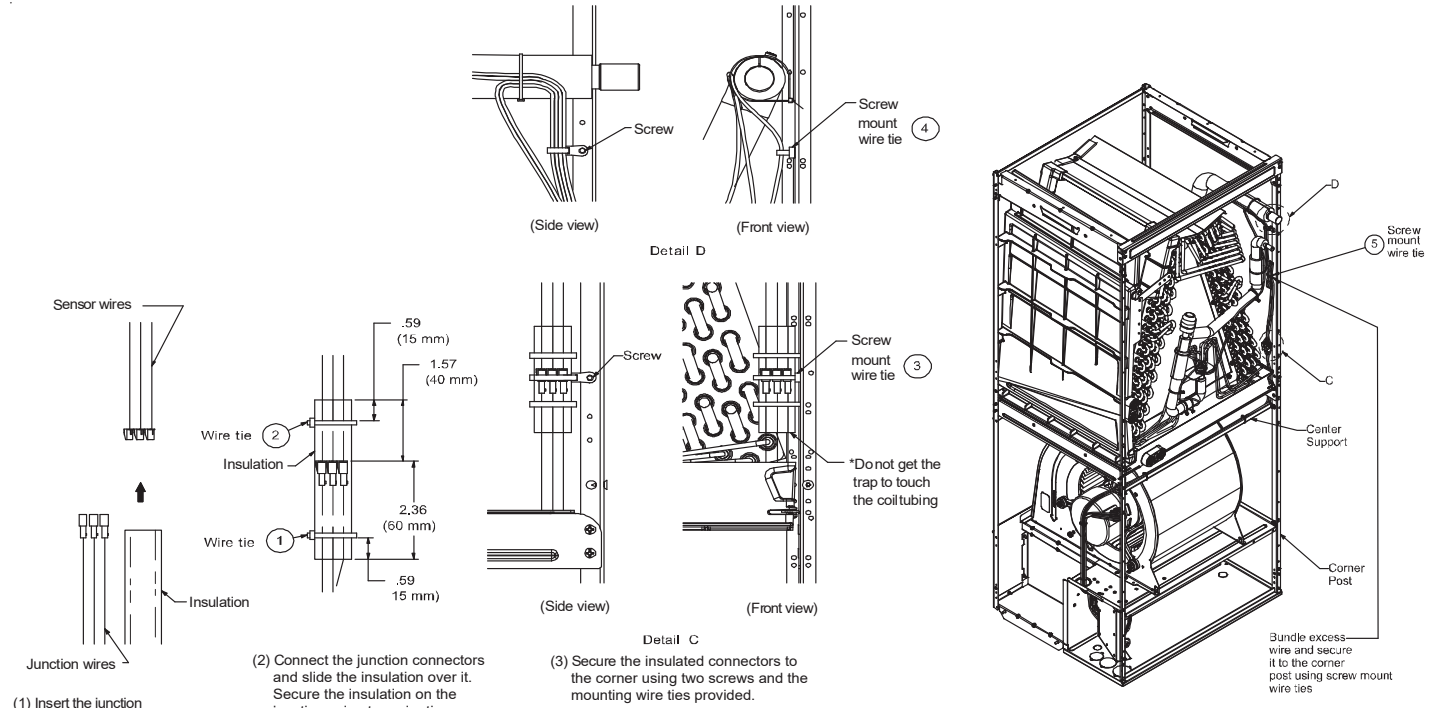

WIRE TIE LOCATION TO BE SECURED

Figure 2-2

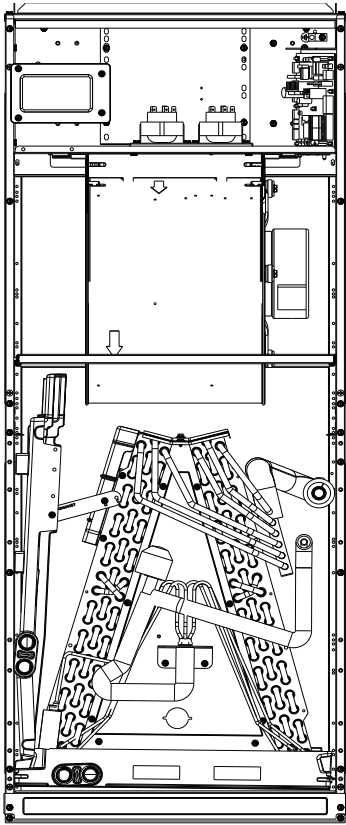

UPLW  
Figure 3

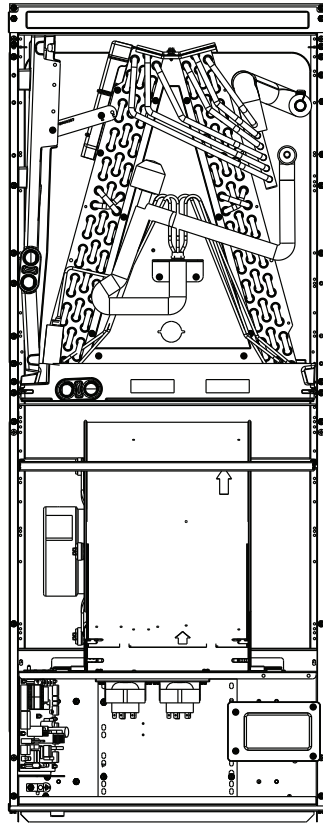

DOWNFLOW  
Figure 4

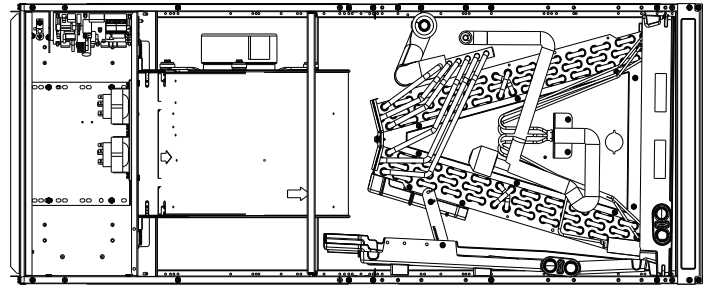

HORIZONTAL LEFT  
Figure 5

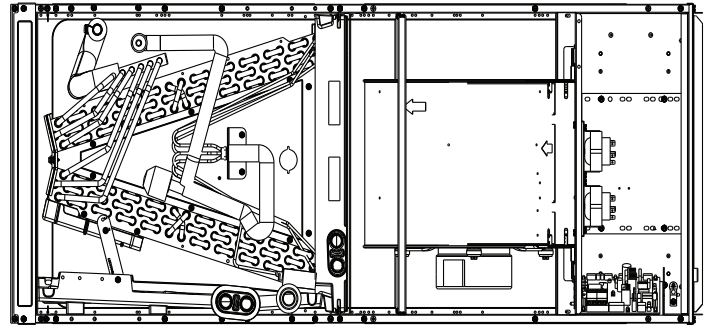

HORIZONTAL RIGHT  
Figure 6

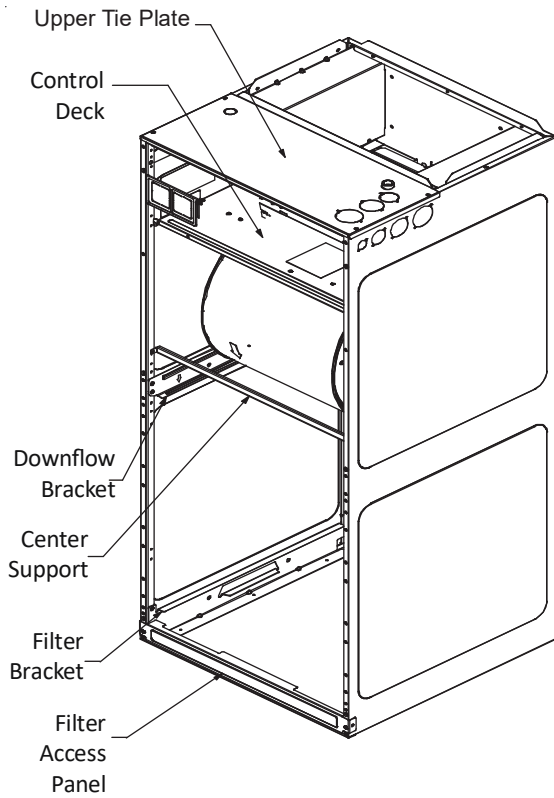

Figure 7

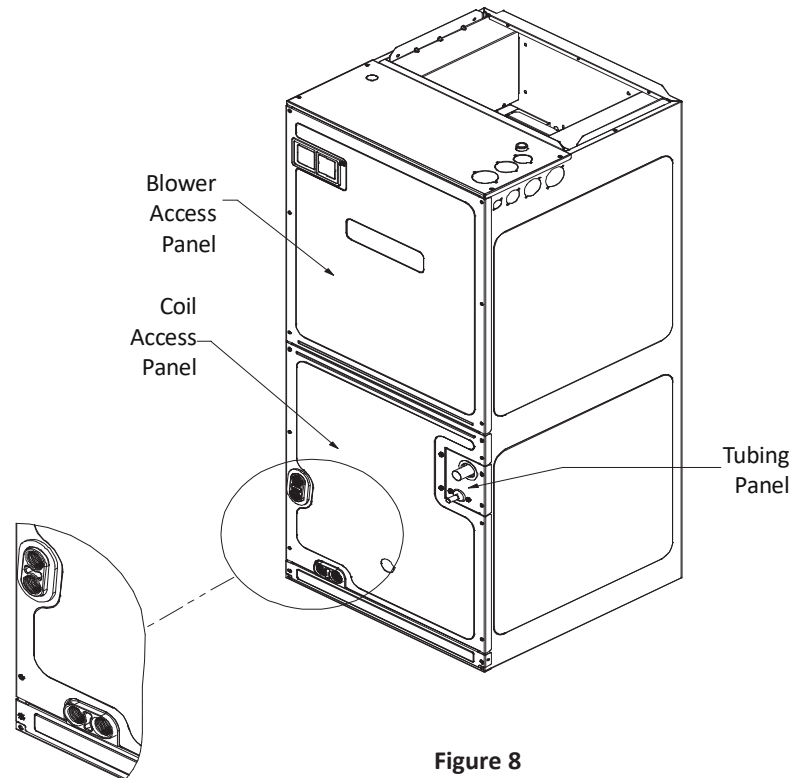

Figure 8

**NOTE:** If removing only the coil access panel from the unit, the filter cover must be removed first. Failure to do so may result in panel damage.

## REFRIGERANT PIPING WORK

Observe the requirements listed below for refrigerant tubing sizes. Refer to Figure 7 and 8 for the location of the components referenced in the following steps.

Drain port labeled (B) in Figure 1 is the primary drain for this application and condensate drain line must be attached to this drain port. Drain port (b) is for the secondary drain line (if used). In applications where the air handler is installed in the horizontal left position, and the return air environment see humidity levels above 65% relative humidity coupled with total external static levels above 0.5" e.s.p., installation may require a field fabricated or field supplied secondary drain pan under the coil cabinet enclosure.

Model	Tubing Size	
	Liquid	Gas
FTQ18/24/30/36/42/48	3/8"	5/8"

Execute heat insulation work completely on both sides of the gas piping and the liquid piping or else a water leakage might result.

Failing to insulate the pipes may cause leaking or burns. Be sure to use the insulation which can withstand such temperatures of 250°F (120°C) or more. Reinforce the insulation on the refrigerant piping according to the installation environment. If the temperature or humidity in the product installation location might reach 86°F or 80%, respectively. Condensation may form on the surface of the insulation.

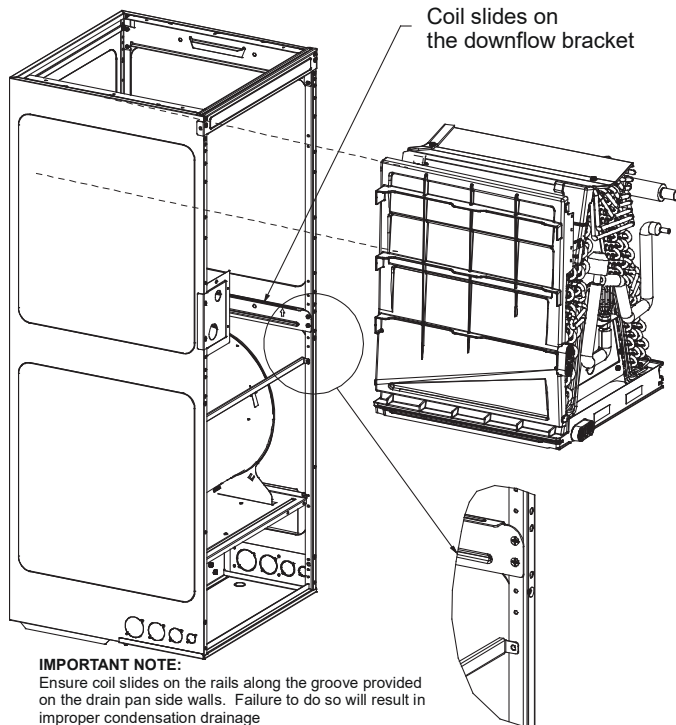

Figure 9

**CAUTION**

USE A TUBE CUTTER AND FLARING BLOCK SUITABLE FOR THE TYPE OR REFRIGERANT.

**CAUTION**

TO PREVENT DUST, MOISTURE OR OTHER FOREIGN MATTER FROM INFILTRATING THE PIPING, EITHER PINCH THE END OR COVER IT WITH TAPE.

**CAUTION**

DO NOT ALLOW ANYTHING OTHER THAN THE DESIGNATED REFRIGERANT TO GET MIXED INTO THE REFRIGERANT CIRCUIT, SUCH AS AIR. IF ANY REFRIGERANT GAS LEAKS WHILE WORKING ON THE UNIT IMMEDIATELY VENTILATE THE ROOM.

1. Cut off the spin closure.
  - The outdoor unit is charged with refrigerant.
  - This coil contains gas under 150 PSIG.
  - Release pressure from the gas piping pressure-release device before initiating piping work.

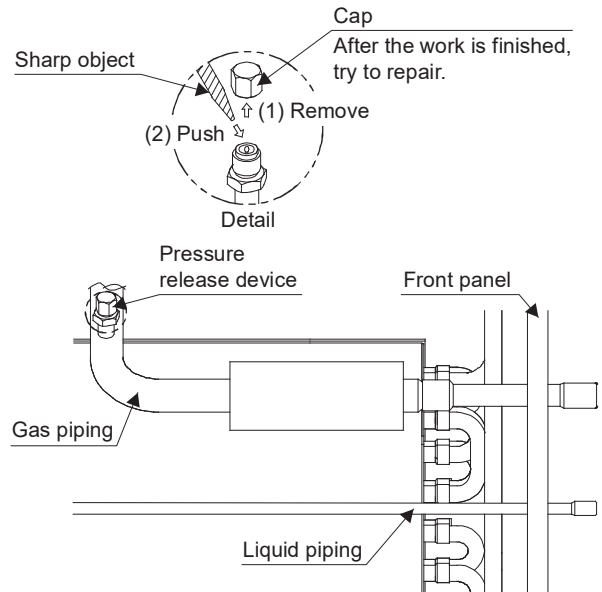

Figure 10

- Cut off the pipe end with a tube cutter. (Both liquid line and gas line.)

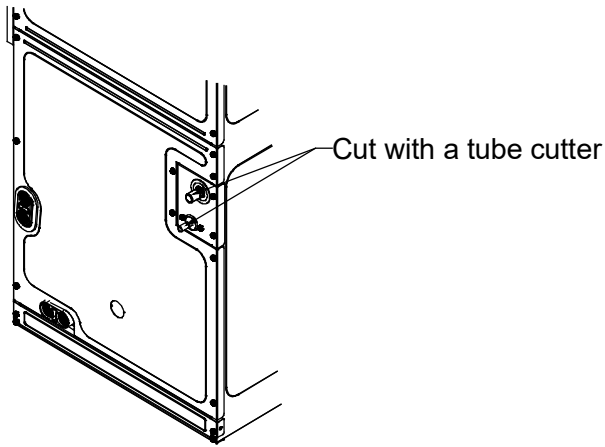

Figure 11

2. Connect the piping.
  - Remove the upper and lower front panels.
  - Slide the front panel (lower) along the field piping until it is far enough away that it will not be affected by heat from the brazing, as shown in Figure 12.
  - Braze up to the field piping fitting port while cooling the sensor and the thermal insulation.
  - Close the upper and lower front panels once heat from the brazed areas has dissipated.

**NOTE: WHEN BRAZING THE FIELD PIPING, COVER THE PIPE INSULATION AND THE THERMAL SENSOR INSIDE THE INSULATION WITH A DAMP CLOTH TO PREVENT ANY DAMAGE TO THE SENSOR OR THE INSULATION. OTHERWISE, THE SENSOR MAY BE DAMAGED BY HEAT OF BRAZING, WHICH LEADS TO A FAILURE OF NORMAL OPERATION.**

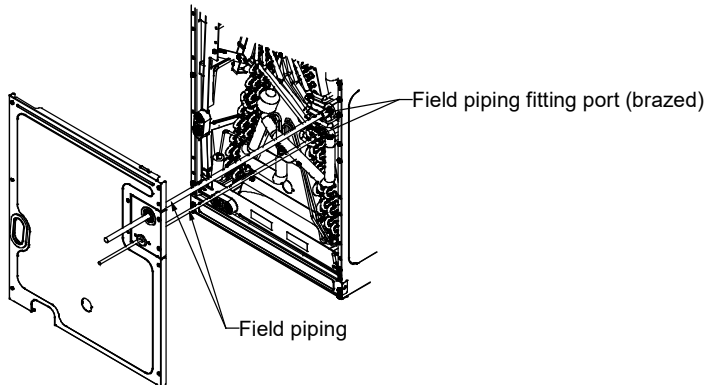

Figure 12

3. After the work is finished, make sure to check that there is no gas leak.
4. After checking for gas leaks, be sure to insulate the piping connections referring to Fig. 13.

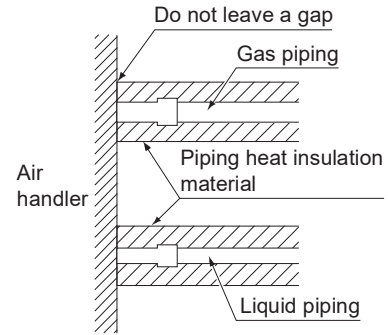

Figure 13



**CAUTION**

**BE SURE TO INSULATE ANY FIELD PIPING ALL THE WAY TO THE PIPING CONNECTION INSIDE THE UNIT. ANY EXPOSED PIPING MAY CAUSE CONDENSATION OR BURNS IF TOUCHED. OTHERWISE, THE SENSOR MAY BE DAMAGED BY HEAT OF BRAZING, WHICH LEADS TO A FAILURE OF NORMAL OPERATION.**

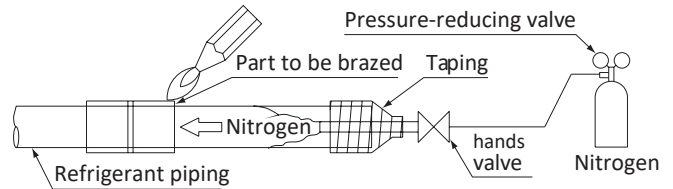

Figure 14



**CAUTION**

**WHEN BRAZING PIPES WHILE FEEDING NITROGEN INSIDE THE PIPING, MAKE SURE TO SET THE NITROGEN PRESSURE TO 2.9 PSI OR LESS USING THE PRESSURE REDUCING VALVE. (THIS PRESSURE IS SUCH THAT A BREEZE IS BLOWN TO YOUR CHEEK.)**



**CAUTION**

**WHEN BRAZING THE REFRIGERANT PIPING, PERFORM NITROGEN REPLACEMENT FIRST OR PERFORM THE BRAZING WHILE FEEDING NITROGEN INTO THE REFRIGERANT PIPING. (REFER TO FIGURE 14.)**



**CAUTION**

**WHEN FOLLOWING THE AIR TIGHT TEST PROCEDURE DURING INSTALLATION (REFER TO THE OUTDOOR UNIT INSTALLATION MANUAL FOR DETAILS), ONLY PRESSURIZE TO 550 PSIG (3.8MPa) WHEN USING FTQ.**

**DANGER: USE OF OXYGEN COULD RESULT IN AN EXPLOSION RESULTING IN SERIOUS INJURY OR DEATH. ONLY USE DRY NITROGEN GAS.**

**DANGER: REFRIGERANT GAS MAY PRODUCE TOXIC GAS IF IT COMES IN CONTACT WITH FIRE SUCH AS FROM A HEATER, STOVE OR COOKING DEVICE. EXPOSURE TO THIS GAS COULD CAUSE SEVERE INJURY OR DEATH.**

**NOTE: Do NOT USE FLUX WHEN BRAZING REFRIGERANT PIPING. THEREFORE, USE THE PHOSPHOR COPPER BRAZING FILLER METAL (BCuP) WHICH DOES NOT REQUIRE FLUX. FLUX HAS AN EXTREMELY NEGATIVE EFFECT ON REFRIGERANT PIPING SYSTEMS. FOR INSTANCE, IF CHLORINE BASED FLUX IS USED, IT WILL CAUSE PIPING CORROSION. FLUX CONTAINING FLUORINE WILL DAMAGE REFRIGERANT OIL.**

## DRAIN PIPING WORK

The coil drain pan has a primary and a secondary drain with 3/4" NPT female connections. The connectors required are 3/4" NPT male, either PVC or metal pipe, and should be hand tightened to a torque of no more than 37 in-lbs. to prevent damage to the drain pan connection. An insertion depth of approximately 3/8" to 1/2" (3-5 turns) should be expected at this torque.

1. Ensure drain pan hole is not obstructed.
2. To prevent potential sweating and dripping on to finished space, it may be necessary to insulate the condensate drain line located inside the building. Use Armaflex® or similar material.

A secondary condensate drain connection has been provided for areas where the building codes require it. Pitch all drain lines a minimum of 1/4" per foot to provide free drainage, or as required by local code. Provide required support to the drain line to prevent bowing. If the secondary drain line is required, run the line separately from the primary drain and end it where condensate discharge can be easily seen.

**NOTE: WATER COMING FROM SECONDARY LINE MEANS THE COIL PRIMARY DRAIN IS PLUGGED AND NEEDS IMMEDIATE ATTENTION.**

**NOTE: INSULATE DRAIN LINES LOCATED INSIDE THE BUILDING OR ABOVE A FINISHED LIVING SPACE TO PREVENT SWEATING. INSTALL A CONDENSATE TRAP TO ENSURE PROPER DRAINAGE.**

**NOTE: SOME INSTALLATION MAY REQUIRE A FIELD FABRICATED OR FIELD SUPPLIED SECONDARY DRAIN PAN UNDER THE COIL CABINET ENCLOSURE. THE INSTALLATION MUST INCLUDE A "P" STYLE TRAP THAT IS LOCATED AS CLOSE AS IS PRACTICAL TO THE EVAPORATOR COIL SEE FIGURE 15 FOR DETAILS OF A TYPICAL CONDENSATE LINE "P" TRAP.**

**NOTE: TRAPPED LINES ARE REQUIRED BY MANY LOCAL CODES. IN THE ABSENCE OF ANY PREVAILING LOCAL CODES, PLEASE REFER TO THE REQUIREMENTS LISTED IN THE UNIFORM MECHANICAL BUILDING CODE. A DRAIN TRAP IN A DRAW-THROUGH APPLICATION PREVENTS AIR FROM BEING DRAWN BACK THROUGH THE DRAIN LINE DURING FAN OPERATION THUS PREVENTING CONDENSATE FROM DRAINING, AND IF CONNECTED TO A SEWER LINE TO PREVENT SEWER GASES FROM BEING DRAWN INTO THE AIRSTREAM DURING BLOWER OPERATION.**

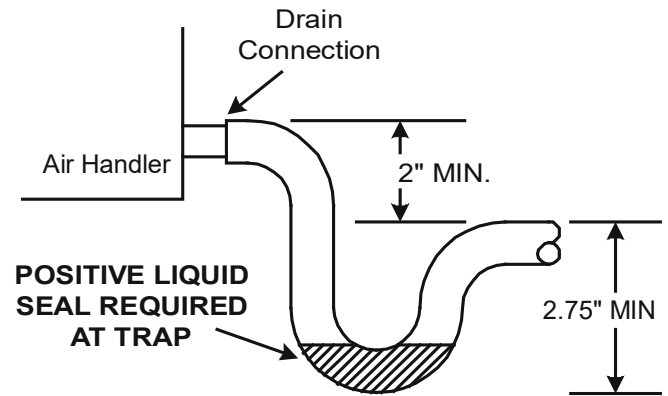

Figure 15

Observe the following guidelines when installing concentrated drain piping. Select the thickness of the concentrated drain piping to reflect the capacity of the machine to which it will be connected. (Install a drain trap for each indoor unit.) See Figure 16.

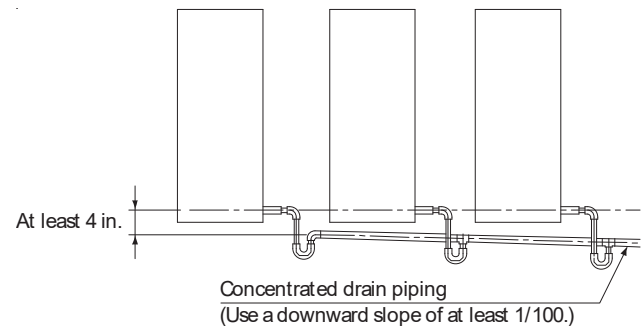

Figure 14

!	CAUTION
IF SECONDARY DRAIN IS NOT INSTALLED, THE SECONDARY ACCESS MUST BE PLUGGED.	

Condensate drain traps with an open vertical Tee between the air handler and the condensate drain trap can improve condensate drainage in some applications, but may cause excessive air discharge out of the open Tee. Daikin does not prohibit this type of drain but we also do not recommend it due to the resulting air leakage. Regardless of the condensate drain design used, it is the installer's responsibility to ensure the condensate drain system is of sufficient design to ensure proper condensate removal from the coil drain pan. Use of a condensate removal pump is permitted when necessary. This condensate pump should have provisions for shutting off the control voltage should a blocked drain occur. See Auxiliary Alarm Switch section for more details. A trap must be installed between the unit and the condensate pump.

### DRAIN PIPING CONNECTION

Do not connect drain piping directly to sewage pipes where ammonia odor may be present. Ammonia in the sewage pipes may enter the indoor unit body through the drain piping and corrode the heat exchanger.

## ELECTRICAL CHARACTERISTICS

Model	Power Supply					IFM		Input (W)	
	Hz	Volts	Voltage Range	MCA	MOP	HP	FLA	Cooling	Heating
FTQ18TBVJUA	60	208/230V	Max. 229V Min. 187V Max. 253V Min. 209V	4.9	15	1/2	3.9	215	215
FTQ24TBVJUA	60	208/230V		4.9	15	1/2	3.9	273	273
FTQ30TBVJUA	60	208/230V		4.9	15	1/2	3.9	407	407
FTQ36TBVJUA	60	208/230V		4.9	15	1/2	3.9	436	436
FTQ42TBVJUA	60	208/230V		6.5	15	3/4	5.2	473	473
FTQ48TBV JUA	60	208/230V		6.5	15	3/4	5.2	518	518
FTQ18TBVJUD	60	208/230V	Max. 229V Min. 187V Max. 253V Min. 209V	4.9	15	1/2	3.9	215	215
FTQ24TBVJUD	60	208/230V		4.9	15	1/2	3.9	273	273
FTQ30TBVJUD	60	208/230V		4.9	15	1/2	3.9	407	407
FTQ36TBVJUD	60	208/230V		4.9	15	1/2	3.9	436	436
FTQ42TBVJUD	60	208/230V		6.5	15	3/4	5.2	473	473
FTQ48TBVJUD	60	208/230V		6.5	15	3/4	5.2	518	518

### SYMBOLS:

MCA: Minimum Circuit Amps (A)

MOP: Max Overcurrent Protective Device (A)

HP: Fan Motor Output (W)

FLA: Full Load Amps (A)

### NOTES:

1. Voltage Range: Units are suitable for use on electrical Systems where voltage supplied to unit terminals is not below or above listed range limits.
2. Maximum allowable voltage imbalance between phases is 2%.
3. Select wire size based on the MCA.

**NOTE: AFTER PIPING WORK IS FINISHED, CHECK DRAINAGE FLOWS SMOOTHLY.**

**NOTE: GRADUALLY INSERT APPROXIMATELY 1 QUART OF WATER INTO THE DRAIN PAN TO CHECK DRAINAGE.**

**IMPORTANT NOTE: THE EVAPORATOR COIL IS FABRICATED WITH OILS THAT MAY DISSOLVE STYROFOAM AND CERTAIN TYPES OF PLASTICS. THEREFORE, A REMOVAL PUMP OR FLOAT SWITCH MUST NOT CONTAIN ANY OF THESE MATERIALS.**

## DUCT WORK

This air handler is designed for a complete supply and return ductwork system. To ensure correct system performance, the ductwork is to be sized to accommodate 350-450 CFM per ton of cooling with the static pressure not to exceed 0.9" in w.c. Refer to ACCA Manual D, Manual S and Manual RS for information on duct sizing and application. Flame retardant ductwork is to be used and sealed to the unit in a manner that will prevent leakage.

**NOTE: A DOWNFLOW APPLICATION WITH ELECTRIC HEAT MUST HAVE AN L-SHAPED SHEET METAL SUPPLY DUCT WITHOUT ANY OUTLETS OR REGISTERS LOCATED DIRECTLY BELOW THE HEATER.**

## RETURN DUCTWORK

Do not locate the return ductwork in an area that can introduce toxic or objectionable fumes/odors into the ductwork. The return ductwork is to be connected to the air handler bottom (upflow configuration).

## ELECTRICAL WIRING WORK

**IMPORTANT:** All routing of electrical wiring must be made through provided electrical knockouts. When removing the electrical knockouts, take care not to damage the PCB. Do not cut, puncture or alter the cabinet for electrical wiring.

**IMPORTANT: INSTALLATION OF AIR HANDLER MUST FOLLOW ANY LOCAL CODES/REGULATIONS. THE MANUFACTURE RECOMMENDS THAT WHEN A HEATER KIT IS NOT INSTALLED, A FIELD SUPPLIED DISCONNECT SWITCH OR BREAKER SHOULD BE INSTALLED IN THE ELECTRICAL CIRCUIT THAT WILL ALLOW POWER TO BE SHUT-OFF FOR SERVICE OR MAINTENANCE.**

### GENERAL INSTRUCTIONS

- Shut off the power before doing any work.
- All field supplied parts and materials, electric works must conform to local codes.
- Use copper wire only.
- See also the "Wiring Diagram Label" located inside the unit's fan housing.

- For details on hooking up the remote controller, refer to the “Remote Controller Installation Manual”.
- All wiring must be performed by an authorized electrician.
- Install a wiring interrupter or ground-fault circuit interrupter for the power wiring.
- To avoid short circuiting the power supply wire, be sure to use insulated terminals.
- Do not turn on the power supply (wiring interrupter or ground-fault circuit interrupter) until all other work is done.

**DANGER:** Do not ground units to water piping, telephone wires or lightning rods because incomplete grounding could cause a severe shock hazard resulting in severe injury or death, not to gas piping because a gas leak could result in an explosion which could lead to severe injury or death.

**WIRE SIZING**

Wire size is important to the operation of your equipment. Use the following check list when selecting the appropriate wire size for your unit.

- Wire used must be sized to carry the Minimum Circuit Ampacity (MCA) listed on the equipment’s Rating Plate.
- Refer to the NEC (USA) or CSA (Canada) for wire sizing. The unit MCA for the air handler and the optional electric heat kit can be found on the unit Series and Rating Plate.
- Wire must be sized to allow no more than a 2% voltage drop from the building breaker/fuse panel to the unit.
- Wires with different insulation temperature rating have varying ampacities - be sure to check the temperature rating used.

Power Supply Wiring (Including ground wire)		Transmission Wiring Remote Controller Wiring	
Field Fuses	Size	Wire	Size
15A	Must comply with local codes	2-conductor, stranded, non-shielded copper/PVC or vinyl jacket	AWG 18-16

Outdoor unit - Indoor unit	Max. 3280 ft. (Total wiring length: 6560 ft.)
Indoor unit - Remote controller	Max. 1640 ft.

**LENGTH OF THE TRANSMISSION WIRING AND REMOTE CONTROLLER WIRING**

**SAFETY DEVICE**

Every installation must include an NEC (USA) or CEC (Canada) approved overcurrent protection device. Also, check with local or state codes for any special regional requirements.

Protection can be in the form of fusing or HACR style circuit breakers. The Series and Rating Plate provides the maximum overcurrent device permissible.

When using residual current operated circuit breakers, be sure to use a high-speed type (0.1 second or less) 30mA rated residual operating current.

**NOTE: FUSES OR CIRCUIT BREAKERS ARE TO BE SIZED LARGER THAN THE EQUIPMENT MCA BUT NOT TO EXCEED THE MOP.**

**ELECTRICAL CONNECTIONS**

**IMPORTANT NOTE: USE COPPER CONDUCTORS ONLY. DISCONNECTION INCORPORATED IN THE FIXED WIRING IN ACCORDANCE WITH THE WIRING RULES.**

Knockouts are provided on the air handler top panel and sides of the cabinet to allow for the entry of the supply voltage conductors, as shown in Figure 17. If the knockouts on the cabinet sides are used for electrical conduit, an adapter ring must be used in order to meet UL 60335-2-40 safety requirements. An NEC or CEC approved strain relief is to be used at this entry point. Some codes/municipalities require the supply wire to be enclosed in conduit. Consult your local codes.

**NOTE: DISCONNECTION MUST BE INCORPORATED IN THE FIXED WIRING IN ACCORDANCE WITH THE WIRING RULES.**

**IMPORTANT: INSTALLATION OF AIR HANDLER MUST FOLLOW ANY LOCAL CODES/REGULATIONS. THE MANUFACTURE RECOMMENDS THAT WHEN A HEATER KIT IS NOT INSTALLED, A FIELD SUPPLIED DISCONNECT SWITCH OR BREAKER MUST BE INSTALLED IN THE ELECTRICAL CIRCUIT THAT WILL ALLOW POWER TO BE SHUT-OFF FOR SERVICE OR MAINTENANCE.**

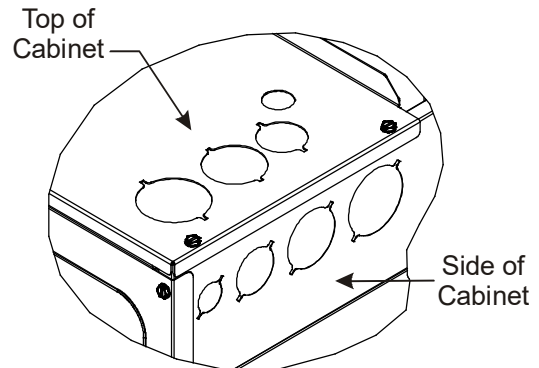



Figure 17

 <b>CAUTION</b>
<p><b>OUTSIDE THE AIR CONDITIONER, DO NOT ROUTE THE REMOTE CONTROLLER WIRING AND TRANSMISSION WIRING TOGETHER WITH OTHER ELECTRICAL WIRING. KEEP THE REMOTE CONTROLLER WIRING AND TRANSMISSION WIRING AT LEAST 2 IN. (50MM) AWAY FROM THE POWER WIRING AND OTHER ELECTRICAL WIRING. EFFECTS OF ELECTRICAL INTERFERENCE (EXTERNAL NOISE) MAY RESULT IN MALFUNCTION AND BREAKDOWN.</b></p>

If the power supply voltage is 208V, change the transformer wire connection from the 240V terminal to the 208V terminal on both transformers.

**Air Handler Only (Non-Heat Kit Models)**

The power supply connects to the stripped black and red wires contained in the air handler electrical compartment. Attach the supply wires to the air handler conductors as shown in the unit wiring diagram using appropriately sized solderless connectors or other NEC or CEC approved means. A ground lug is also provided in the electrical compartment. The ground wire from the power supply must be connected to this ground lug.

**NOTE: AIR HANDLER WITH DISCONNECT SWITCH - ATTACH THE SUPPLY WIRES TO THE DISCONNECT SWITCH TERMINALS AS SHOWN IN THE UNIT WIRING DIAGRAM USING APPROPRIATELY SIZED SOLDERLESS CONNECTORS OR OTHER NEC OR CEC APPROVED MEANS. A GROUND LUG IS ALSO PROVIDED ON THE DISCONNECT SWITCH MOUNT BRACKET (FIGURE 18) IN THE ELECTRICAL COMPARTMENT. THE GROUND WIRE FROM THE POWER SUPPLY MUST BE CONNECTED TO THIS GROUND LUG.**

**Air Handler / Non-Circuit Breaker Heat Kits**

A terminal block is provided with the HKS and HKTS kit to attach the power supply and air handler connections. Follow the HKS and HKTS Installation Manual and wiring diagram for complete wiring details.

**NOTE: AIR HANDLER WITH DISCONNECT SWITCH - DO NOT USE DISCONNECT SWITCH ASSEMBLY INSIDE THE UNIT WHILE INSTALLING HEAT KIT. REFER FIGURE 18 TO KNOW HOW TO REMOVE DISCONNECT SWITCH ASSEMBLY FROM UNIT.**

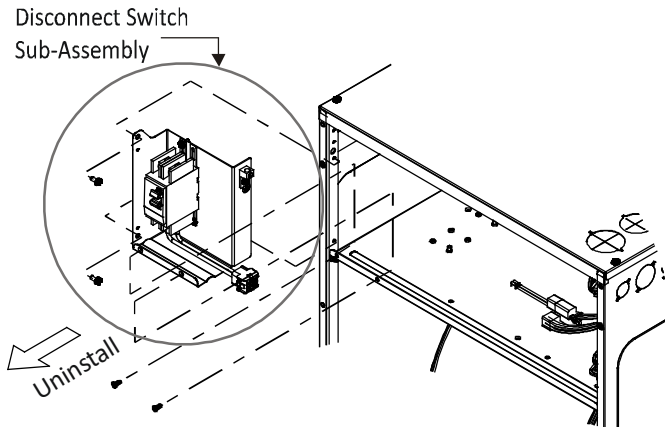

FIGURE 18

**NOTE: TRANSFORMER SUB-ASSEMBLY**

Before installing the Heat Kit, uninstall the transformer sub-assembly (Figure 19). Make sure to unplug 12 pin connector before uninstalling the transformer sub-assembly. Follow the Heat Kit Installation Manual to install the Heat Kit. Install transformer sub-assembly back to the unit (Figure 19). Plug in 12-Pin connectors

and secure screws while installing transformer sub-assembly back to the unit after heater kit installation.

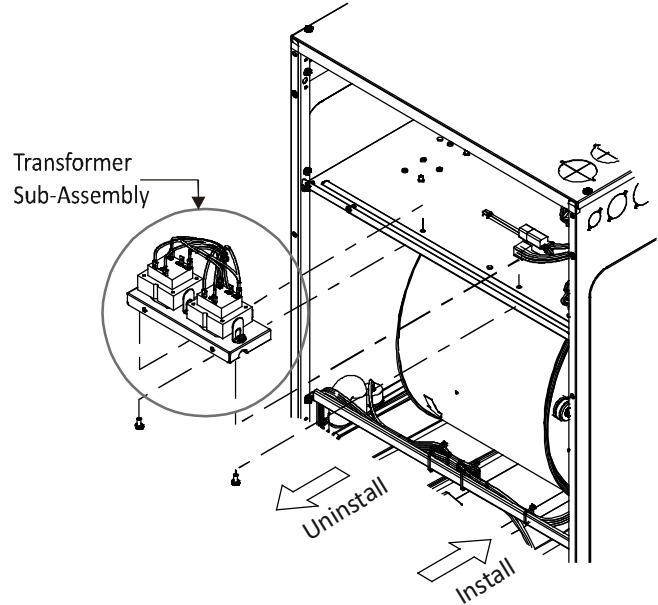

Figure 19

**Air Handler with Circuit Breaker Heat Kit**

The circuit breakers have lugs for power supply connection. See the HKS and HKTS Installation Instructions for further details.

	<b>WARNING</b>
<p><b>USE ONLY SPECIFIED WIRE AND CONNECTS TO TERMINALS TIGHTLY. BE CAREFUL THAT WIRES DO NOT PLACE EXTERNAL STRESS ON TERMINALS. KEEP WIRE IN NEAT ORDER; NOT TO OBSTRUCT OTHER EQUIPMENT. MAKE SURE THAT THE ACCESS PANEL CLOSED TIGHTLY. INCOMPLETE CONNECTIONS COULD RESULT IN OVERHEATING, AND IN WORSE CASES, ELECTRIC SHOCK OR FIRE.</b></p>	

**NOTE: NEVER CONNECT POWER SUPPLY WIRING TO THE TERMINAL BLOCK FOR REMOTE CONTROLLER WIRING AS THIS COULD DAMAGE THE ENTIRE SYSTEM.**

	<b>WARNING</b>
<p><b>WHEN DOING THE WIRING, MAKE SURE THE WIRING IS NEAT AND DOES NOT CAUSE THE ACCESS PANEL TO STICK UP, AND THEN CLOSE THE COVER FIRMLY. WHEN ATTACHING THE ELECTRIC COMPONENT BOX COVER, MAKE SURE YOU DO NOT PINCH ANY WIRES.</b></p>	

**Precautions**

- Refer to the “REMOTE CONTROLLER INSTALLATION MANUAL” on how to install and lay the wiring for the remote controller.
- See also the “Wiring Diagram Label” located inside the unit’s fan housing.
- Connect the remote controller and transmission wiring their respective terminal blocks.

**WIRING EXAMPLE**

Power supply  
208/230V

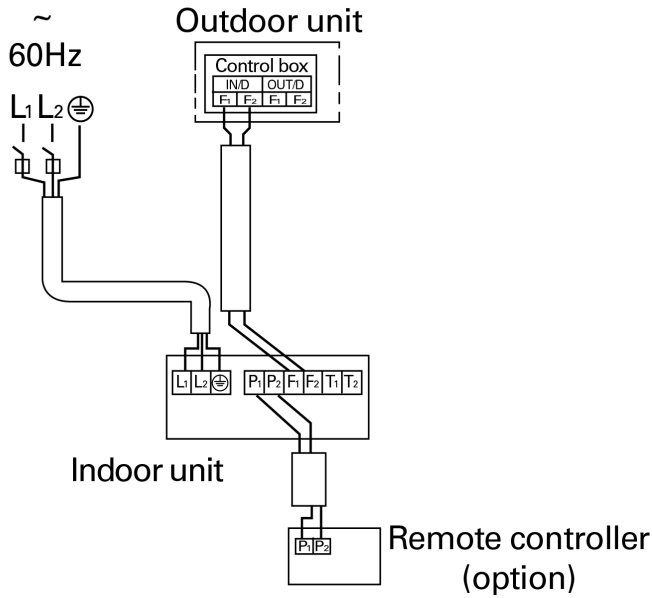

Figure 21

Power supply  
208/230V

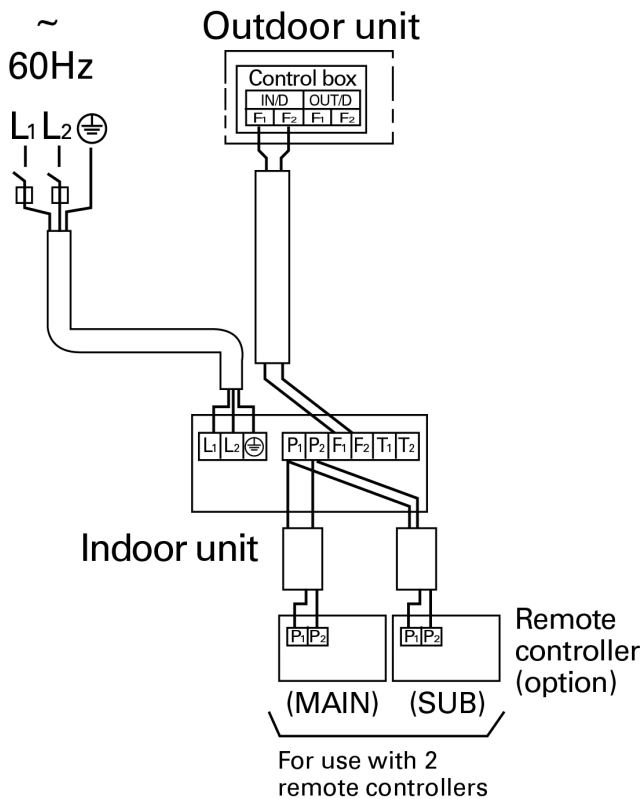

Figure 21

**CONTROL BY 2 REMOTE CONTROLLERS**

**Controlling 1 indoor unit by 2 remote controllers**

When using 2 remote controllers, one must be set to "MAIN" and the other to "SUB". Refer to the installation manual of the controller for setting the "MAIN" and "SUB" controller.

**Precautions**

- Daisy chain wiring is needed when using group control and 2 remote controllers at the same time.
- Connect the indoor unit at the end of the crossover wire (P1, P2) to remote controller 2 (SUB).

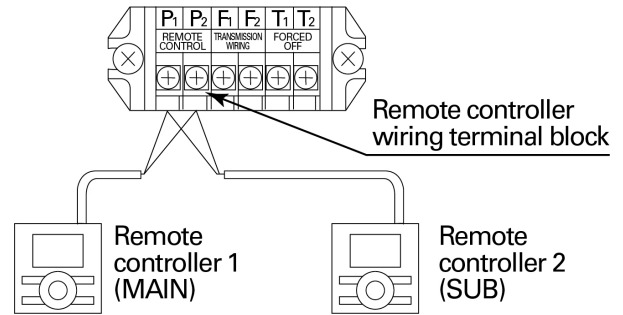

Figure 22

**REMOTE CONTROL (FORCED OFF AND ON OPERATION)**

- Connect input lines from the outside to the terminals T1 and T2 on the terminal block (8P) for remote controller to achieve remote control.
- See the "FIELD SETTING AND TEST RUN" for details on operation.

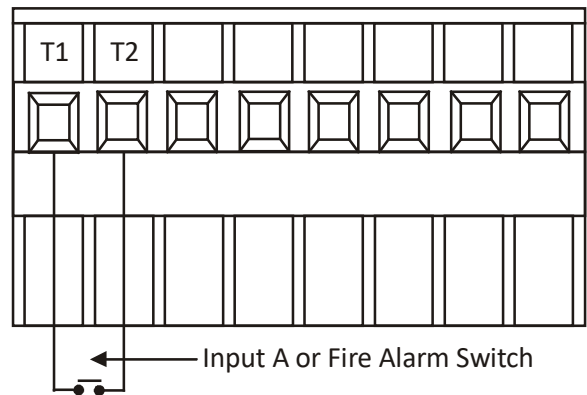

Figure 23

Wire specification	Sheathed vinyl cord or cable (2 wires)
Gauge	AWG18 - 16
Length	Max. 328 ft.
External terminal	Contact that can ensure the minimum applicable load of 16 V DC, 1mA.

**FIRE ALARM SWITCH**

The control is equipped with two Fire Alarm terminals, labeled T1 and T2 which are typically utilized in series. The fire alarm switch must be normally closed and open when the alarm occurs.

For example, a normally closed fire alarm switch will open when the CO<sub>2</sub> reaches a particular level. The control will respond by turning off whole system (all indoor units and outdoor unit) and displaying the proper fault codes.

(The switch is closed as part of the default factory setting.)

The error will be maintained in the equipment's fault history. See picture (Figure 23) for the connection location. Refer to Table 5 for fire alarm setting.

#### AUXILIARY ALARM SWITCH

The control is equipped with two Auxiliary Alarm terminals, labeled TB4 and TB5 (2VA or less) which are typically utilized in series with a condensate switch.

The auxiliary alarm switch must be normally closed and open when the alarm occurs. For example, a normally closed condensate switch will open when the base pan's water level reaches a particular level. The control will respond by turning off the blower motor and outdoor unit and displaying the proper fault codes.

If the switch is later detected closed for 30 seconds, normal operation resumes and the error message is removed. (The switch is closed as part of the default factory setting.) The error will be maintained in the equipment's fault history. See Figure 28.

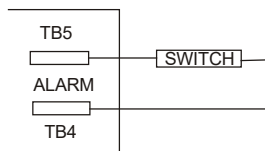

Figure 24

#### CENTRALIZED CONTROL

For centralized control, it is necessary to designate the group No. For details, refer to the manual of each optional controller for centralized control.

## FIELD SETTING

**Field settings may have to be performed using the remote controller, depending on the type of installation.**

1. Make sure the electric component box covers are closed on the indoor and outdoor units.
  2. Depending on the type of installation, make the field settings from the remote controller after the power is turned on, following the "Field Settings" manual which came with the remote controller.
- The settings can select "Mode No.", "FIRST CODE NO." and "SECOND CODE NO."
  - Field settings are normally applied to the entire remote control group, however if individual indoor units in the remote control group require specific settings or for confirmation that settings have been established, utilize the "Mode No." in parenthesis.
  - The "Field Settings" included with the remote controller lists the order of the settings and method of operation.
  - Make sure the customer keeps the "Field Settings" manual, along with the operating manual, in a safe place.

**SETTINGS WHEN USING THE OPTIONAL REMOTE SENSOR**

This product does not include an air inlet thermistor. It uses a remote controller thermistor for control purposes. For this reason, it is necessary to install an optional remote sensor in the following cases:

- When the remote controller will be installed at a location where it cannot accurately measure the indoor temperature.
- When using a remote controller without a built-in thermistor (simple remote controller, wireless remote controller, no remote controller).
- When using an optional remote sensor, change the settings as described Table 3:

ROOM TEMPERATURE SENSOR SELECTION	MODE NO.	FIRST CODE NO.	SECOND CODE NO.
To use only the remote sensor	10 (20)	2	02
To use only the remote controller thermistor			03*

Table 3

Indoor units settings must be changed to Available as per Table 4 when group remote control is used. Indoor units not using group remote control may remain on factory settings.

Remote Controller Thermistor (Group Control Only)	Mode No.	FIRST CODE NO.	SECOND CODE NO.
Not available	10 (20)	6	01*
Available			02

\* Factory Set

Table 4

**REMOTE CONTROL SETTING (T1, T2)**

Forced off and ON/OFF operation should be selected by selecting the SECOND CODE NO. as shown in Table 5.

External ON/OFF input	Mode No.	FIRST CODE NO.	SECOND CODE NO.
Forced Off	12/(22)	1	01*
ON/OFF Operation			02
System/Equipment Protection			03

Table 5

Input A of forced off and ON/OFF operation work as shown in Table 6.

Model	Mode No.	First Code No.	HEATER (kW)							
			No Heat Kit	3	5	6	8	10	15	19
			Second Code No.							
			01*	02	03	04	05	06	07	08
FTQ18TBVJUA	11(21)	5	X	X	X	X	X	X		
FTQ18TBVJUD			X	X	X	X	X	X		
FTQ24TBVJUA			X	X	X	X	X	X		
FTQ24TBVJUD			X	X	X	X	X	X		
FTQ30TBVJUA			X	X	X	X	X	X		
FTQ30TBVJUD			X	X	X	X	X	X		
FTQ36TBVJUA			X	X	X	X	X	X		
FTQ36TBVJUD			X	X	X	X	X	X		
FTQ42TBVJUA			X		X	X	X	X	X	X
FTQ42TBVJUD			X		X	X	X	X	X	X
FTQ48TBVJUA			X		X	X	X	X	X	X
FTQ48TBVJUD			X		X	X	X	X	X	X

*	Factory Set
X	Available
	Not Available

Forced Off	ON/OFF Operation	System/ Equipment Protection
Input A "on" to force a stop (remote controller reception prohibited)	Unit operated by changing input A from "off" to "on"	Input A "off" to stop system
Input A "off" to allow remote controller	Unit stopped by changing input A from "on" to "off"	

Table 6

### SETTING THE FILTER SIGN DISPLAY INTERVAL

- Explain the following to the customer if the filter dirt settings have been changed.
- The filter sign display time is set to 2500 hours (equivalent to 1 year's use) when shipped.
- The settings can be changed to not display.
- When installing the unit in a dusty place, set the filter sign display time to shorter intervals (1,250 hours).
- Explain to the customer that the filter needs to be cleaned regularly to prevent clogging and also the time that is set.

Mode No.	FIRST CODE NO.		SECOND CODE NO.	
			01	02
10 (20)	0	Filter dirt	low	high
	1 (low/high)	Displayed time (units: hours)	2500/ 1250	10000/ 5000
	3	Filter sign display	ON	OFF

### RETURN AIR FILTER

**NOTE: IF INSTALLING A FILTER, AN EXTERNAL FILTER MUST BE USED WHEN INSTALLING THE UNIT IN HORIZONTAL RIGHT, OR IF THE SIDE DRAIN PAN IS NOT REMOVED FOR DOWN FLOW APPLICATION. A FILTER WILL NOT FIT ON THE INTERNAL FILTER RAILS IN THESE APPLICATIONS.**

Each installation must include a return air filter. This filtering may be performed at the air handler using the factory filter rails or externally such as a return air filter grille. When using the factory filter rails, a nominal 16x20x1", 20x20x1" or 24x20x1" (actual dimension must be less than 23-1/2"x20") filter can be installed. Washable versions are available through your local Daikin distributor.

 <b>CAUTION</b>
<b>DO NOT OPERATE THIS PRODUCT WITHOUT ALL THE DUCTWORK ATTACHED.</b>

### ELECTRIC HEAT

Refer to the installation manual provided with the electric heat kit for the correct installation procedure. All electric heat must be field installed. If installing this option, the ONLY heat kits that are permitted to be used are the Daikin

produced HKS and HKTS series. Refer to the air handler unit's Serial and Rating plate or the HKS and HKTS specification sheets to determine the heat kits compatible with a given air handler. No other accessory heat kit besides the HKS and HKTS series may be installed in these air handlers. The heating mode temperature rise is dependent upon the system airflow, the supply voltage, and the heat kit size (kW) selected. For installations not indicated above the following formula is to be used:

$$TR = (kW \times 3412) \times (\text{Voltage Correction}) / (1.08 \times CFM)$$

Where:

- TR = Temperature Rise
- kW = Heater Kit Actual kW
- 3412 = Btu per kW
- VC\* = .96 (230 Supply Volts)
- = .92 (220 Supply Volts)
- = .87 (208 Supply Volts)
- 1.08 = Constant
- CFM = Measured Airflow
- \*VC (Voltage Correction)

**NOTE: THE TEMPERATURE RISE CALCULATIONS CAN ALSO BE USED TO ESTIMATE THE AIR HANDLER AIRFLOW DELIVERY. WHEN USING THESE TABLES FOR THIS PURPOSE SET THE ROOM THERMOSTAT TO MAXIMUM HEAT AND ALLOW THE SYSTEM TO REACH STEADY STATE CONDITIONS. INSERT TWO THERMOMETERS, ONE IN THE RETURN AIR AND ONE IN THE SUPPLY AIR. THE TEMPERATURE RISE IS THE SUPPLY AIR TEMPERATURE MINUS THE RETURN AIR TEMPERATURE. USING THE TEMPERATURE RISE CALCULATED, CFM CAN BE ESTIMATED FROM THE TR FORMULA ABOVE. SEE SPECIFICATION SHEET AND/OR SERVICE MANUAL FOR MORE INFORMATION.**  
11(21)-3-XX

XX	01 (*)	02	07	08
<b>Heater Operation</b>	Electric Heater with Heat Pump not allowed	Electric Heater with Heat Pump allowed	Electric Heater with Heat Pump not allowed	Electric Heater with Heat Pump allowed
<b>Electric Heater run for Defrost/oil return operation</b>	Not Allowed	Not allowed	Allowed	Allowed

\*Factory Set

Electric Heater Setting  
Mode No. 11(21)  
First Code No. 3  
Second Code No. XX

### ELECTRIC HEATER ON/OFF TEMPERATURE SETTING

When an auxiliary heater is installed and controlled by the indoor unit, the heater ON/OFF temperatures, Ton and Toff, can be selected individually by switching the 1st code and 2nd code according to the following table.

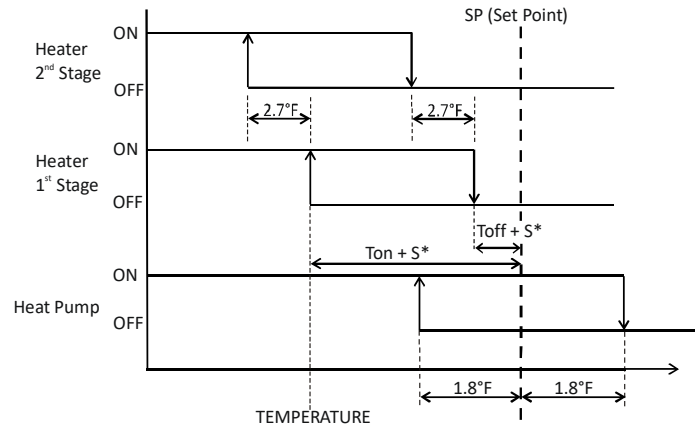

\*“S” Value varies automatically based on the room temperature trend

### ELECTRIC HEATER & HEAT PUMP OPERATION MODE

Figure 25

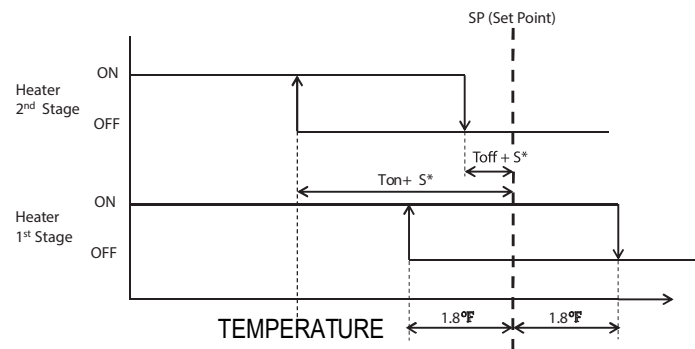

\*“S” Value varies automatically based on the room temperature trend

### ELECTRIC HEATER & HEAT PUMP OPERATION MODE

Figure 26

Perform on-site setting using the remote controller. Temperature difference must be 3.6°F or more between “Ton” and “Toff” to activate setting(s).

SYMBOL	MODE NO.	FIRST CODE	SECON CODE NO.					
			01*	02	03	04	05	06
Ton	11(21)	1	-7.2 (-4.0)	-6.3 (-3.5)	-5.4 (-3.0)	-4.5 (-2.5)	-3.6 (-2.0)	-2.7 (-1.5)
Toff		2	-3.6 (-2.0)	-2.7 (-1.5)	-1.8 (-1.0)	-0.9 (-0.5)	0 (0)	0.9 (0.5)

\*Factory Set

### DRY MODE 2.0

14(24)-5-XX

- Choose dry mode settings as per following table:

XX	01 (*)	02
<b>DRY mode</b>	Set Point = Room Temperature	Set Point became same as cooling mode set point

Mode No. 14(24)  
First Code No. 5  
Second Code No. XX

### ACCESSORIES

- Installation of the humidifier and economizer: Humidifier and economizer (11.5VA each terminal) are sold separately. For the method of installation, refer to the manual provided with each optional product.



### WARNING

**IF THE UNIT IS INSTALLED WITH AN ELECTRIC HEATER, INSTALL THE OPTIONAL PRODUCT AT A LOCATION WHERE IT IS NOT EXPOSED DIRECTLY TO THE HEAT FROM THE ELECTRIC HEATER. DIRECT EXPOSURE TO HEAT CAN RESULT IN AN EQUIPMENT MALFUNCTION OR FIRE.**

- Connect the wires.
  - Run the wires through knockout hole.
  - Connect the wires to the terminal block of the product. Refer to wiring diagram inside the unit for wire connections.
- On-site setting of air purifier/humidifier.

Terminal Name	Input/output signal
CONTROL ON/OFF	Outputs: indoor unit ON (AC 24V) 11.5VA or less
ECONOMIZER 2	Output: indoor unit cooling THERMO ON (AC 24V) 11.5VA or less
ECONOMIZER 1	Receives input: Economizer operation ON (Dry contact)
HUMIDIFIER	Receives input: Humidifier operation ON (Dry contact)
AIR CLEANER	Receives input: Air purifier operation ON (Dry contact)

14(24)-4-XX

**Optional kit setting 14(24)- 4-XX**

XX	01	02	03	04	05
Humidifier Fan speed	Refer to controller	High	Refer to controller	High	Refer to controll
Economizer setting for Mech standby duration (min)	10	10	20	20	30

XX	06	07	08	09	10
Humidifier Fan speed	High	Refer to controller	High	Refer to controll	High
Economizer setting for Mech standby duration (min)	30	40	40	50	50

XX	11	12	13	14 (*)
Humidifier Fan speed	Refer to controller	High	Refer to controller	High
Economizer setting for Mech standby duration (min)	60	60	Free cooling only	Free cooling only

(\*) Factory Set

Humidifier + Economizer  
Optional Kit Setting  
Mode No. 14(24)  
First Code No. 4  
Second Code No. XX

**SETTING FOR SEPARATELY SOLD ACCESSORIES**

- See the instruction manuals included with optional accessories for the necessary settings.

**WHEN USING A WIRELESS REMOTE CONTROLLER**

- A wireless remote controller address needs to be set when using a wireless remote controller. See the installation manual included with the wireless remote controller for details on how to make the settings.

**TEST RUN**

- Perform a test run according to the outdoor unit's installation manual.
- The operation lamp of the remote controller will flash when a malfunction occurs. Check the malfunction code on the liquid crystal display to identify the point of trouble. An explanation of malfunction codes and the corresponding trouble is provided in "CAUTION FOR SERVICING" of the outdoor unit.
- If the display shows any of the following, there is a possibility that the wiring was done incorrectly or that the power is not on, so check again.

Remote control display	Content
" "  " display	There is a short circuit at the FORCED OFF terminals (T1 T2).
"U3" display	The test-run has not been performed.
"U4" display "UH" display	The power on the indoor unit is off. The outdoor unit has not been wired for power supply. Wiring is incorrect for the transmission wiring and/or FORCED OFF wiring. The transmission wiring is cut.
"UF" display	Reversed transmission wiring
No display	The power on the indoor unit is off. The indoor unit has not been wired for power supply. Wiring is incorrect for the remote controller wiring, transmission wiring and/or FORCED OFF wiring. The transmission wiring is cut.

	<b>CAUTION</b>
<b>ALWAYS STOP THE TEST RUN USING THE REMOTE CONTROLLER TO STOP OPERATION.</b>	



# START-UP CHECKLIST

Condenser / Heat Pump (including all Inverter)			
	Model Number	_____	
	Serial Number	_____	
<b>ELECTRICAL (Outdoor Unit)</b>			
Line Voltage (Measure L1 and L2 Voltage)	L1 - L2	_____	
Secondary Voltage (Measure Transformer Output Voltage) <b>NOT ALL MODELS</b>	R - C	_____	
Compressor Amps		_____	
Condenser Fan Amps		_____	
<b>TEMPERATURES (Indoor Unit)</b>			
Return Air Temperature (Dry bulb / Wet bulb)		_____ DB °F	_____ WB °F
Cooling Supply Air Temperature (Dry bulb / Wet bulb)		_____ DB °F	_____ WB °F
Delta T (Difference between Supply and Return Temperatures)		_____ DB °F	
<b>PRESSURES / TEMPERATURES (Outdoor Unit)</b>			
Suction Circuit (Pressure / Suction Line Temperature)	PSIG	_____	TEMP _____ °F
Liquid Circuit (Pressure / Liquid Temperature)	PSIG	_____	TEMP _____ °F
Outdoor Air Temperature (Dry bulb / Wet bulb)		_____ DB °F	_____ WB °F
<b>SUPERHEAT / SUBCOOLING</b>			
Line set length in Feet	SH	_____	SC _____
Additional Refrigerant Charge Added over Factory Charge (Ounces)		_____	
		_____	
<b>Additional Checks</b>			
Check wire routings for any rubbing		_____	
Check factory wiring and wire connections.		_____	
Check product for proper clearances as noted by installtion instructions		_____	
		_____	
°F to °C formula: $(^{\circ}\text{F} - 32) \text{ divided by } 1.8 = ^{\circ}\text{C}$ °C to °F formula: $(^{\circ}\text{C} \text{ multiplied by } 1.8) + 32 = ^{\circ}\text{F}$			

# AIR HANDLER

## AIR HANDLER HOMEOWNER'S ROUTINE MAINTENANCE RECOMMENDATIONS

We strongly recommend a bi-annual maintenance checkup be performed before the heating and cooling seasons begin by a qualified servicer.

### REPLACE OR CLEAN FILTER

**IMPORTANT NOTE:** Never operate unit without a filter installed as dust and lint will build up on internal parts resulting in loss of efficiency, equipment damage and possible fire.



An indoor air filter must be used with your comfort system. A properly maintained filter will keep the indoor coil of your comfort system clean. A dirty coil could cause poor operation and/or severe equipment damage.

Your air filter or filters could be located in your furnace, in a blower unit, or in "filter grilles" in your ceiling or walls. The installer of your air conditioner or heat pump can tell you where your filter(s) are, and how to clean or replace them.

Check your filter(s) at least once a month. When they are dirty, replace or clean as required. Disposable type filters should be replaced. Reusable type filters may be cleaned. You may want to ask your dealer about high efficiency filters. High efficiency filters are available in both electronic and non-electronic types. These filters can do a better job of catching small airborne particles.

### MOTORS

Indoor and outdoor fan motors are permanently lubricated and do not require additional oiling.

	<b>WARNING</b>
<b>HIGH VOLTAGE</b> DISCONNECT ALL POWER BEFORE SERVICING OR INSTALLING THIS UNIT. MULTIPLE POWER SOURCES MAY BE PRESENT. FAILURE TO DO SO MAY CAUSE PROPERTY DAMAGE, PERSONAL INJURY OR DEATH.	

### ALUMINUM INDOOR COIL CLEANING (QUALIFIED SERVICER ONLY)

This unit is equipped with an aluminum tube evaporator coil. The safest way to clean the evaporator coil is to simply flush the coil with water. This cleaning practice remains as the recommended cleaning method for both copper tube and aluminum tube residential evaporator coils.

It has been determined that many coil cleaners and drain pan tablets contain corrosive chemicals that can be harmful to aluminum tube and fin evaporator coils. Even a one-time application of these corrosive chemicals can cause premature aluminum evaporator coil failure. Any cleaners that contain corrosive chemicals including, but not limited to, chlorine and hydroxides, should not be used.

An alternate cleaning method is to use one of the products listed in TP-109\* to clean the coils. The cleaners listed are the only agents deemed safe and approved for use to clean round tube aluminum coils. TP-109 is also available on the web site in Partner Link > Service Toolkit.

**NOTE:** Ensure coils are rinsed well after use of any chemical cleaners.

	<b>CAUTION</b>
<b>TO AVOID RISK OF EQUIPMENT DAMAGE OR FIRE, INSTALL THE SAME AMPERAGE BREAKER OR FUSE AS YOU ARE REPLACING. IF THE CIRCUIT BREAKER OR FUSE SHOULD OPEN AGAIN WITHIN THIRTY DAYS, CONTACT A QUALIFIED SERVICER TO CORRECT THE PROBLEM. IF YOU REPEATEDLY RESET THE BREAKER OR REPLACE THE FUSE WITHOUT HAVING THE PROBLEM CORRECTED, YOU RUN THE RISK OF SEVERE EQUIPMENT DAMAGE.</b>	

### BEFORE YOU CALL YOUR SERVICER

- Check the thermostat to confirm that it is properly set.
- Wait 15 minutes. Some devices in the outdoor unit or in programmable thermostats will prevent compressor operation for awhile, and then reset automatically. Also, some power companies will install devices which shut off air conditioners for several minutes on hot days. If you wait several minutes, the unit may begin operation on its own. Check the electrical panel for tripped circuit breakers or failed fuses. Reset the circuit breakers or replace fuses as necessary.
- Check the disconnect switch near the indoor furnace or blower to confirm that it is closed.
- Check for obstructions on the outdoor unit. Confirm that it has not been covered on the sides or the top. Remove any obstruction that can be safely removed. If the unit is covered with dirt or debris, call a qualified servicer to clean it.
- Check for blockage of the indoor air inlets and outlets. Confirm that they are open and have not been blocked by objects (rugs, curtains or furniture).

**THIS PAGE LEFT INTENTIONALLY BLANK**

**THIS PAGE LEFT INTENTIONALLY BLANK**

**CUSTOMER FEEDBACK**

Daikin Comfort Technologies is very interested in all product comments.

Please fill out the feedback form on the following link:

<https://daikincomfort.com/contact-us>

You can also scan the QR code on the right to be directed to the feedback page.



Our continuing commitment to quality products may mean a change in specifications without notice.

©2018, 2021, 2023 **DAIKIN COMFORT TECHNOLOGIES MANUFACTURING, L.P.**

19001 Kermier Rd., Waller, TX 77484

[www.daikincomfort.com](http://www.daikincomfort.com)