

INSTALLATION MANUAL

SPLIT SYSTEM

Air Conditioners

MODELS

Ceiling-mounted Duct type

FBA18AAVJU

FBA24AAVJU

FBA30AAVJU

FBA36AAVJU

FBA42AAVJU

FBA48AAVJU

English

Français

Español

Please visit <http://www.daikinac.com/content/resources/manuals> for the most current version of installation instructions and service manual. In the event of conflicting information, the online contents are to be used.

Veillez visiter <http://www.daikinac.com/content/resources/manuals> pour obtenir la version la plus récente des instructions d'installation et du manuel de service. En cas de conflit d'informations, le contenu en ligne est à privilégier.



Visite <http://www.daikinac.com/content/resources/manuals> para obtener la versión más actualizada de las instrucciones de instalación y el manual de servicio en español. En caso de información contradictoria, debe utilizarse el contenido en línea.

CONTENTS

1. SAFETY CONSIDERATIONS	1
2. BEFORE INSTALLATION	3
3. SELECTION OF INSTALLATION LOCATION.....	4
4. PREPARATION BEFORE INSTALLATION	5
5. INSTALLATION OF INDOOR UNIT	7
6. REFRIGERANT PIPING WORK.....	8
7. DRAIN PIPING WORK	10
8. DUCT WORK.....	13
9. ELECTRIC WIRING WORK.....	13
10. FIELD SETTING	17
11. TEST OPERATION.....	19

1. SAFETY CONSIDERATIONS

Refer also to the General safety considerations attached to the outdoor unit.





	Read the safety considerations in this manual carefully before operating the unit.
	This appliance is filled with R32.

Read these **SAFETY CONSIDERATIONS for Installation** carefully before installing air conditioning equipment. After completing the installation, make sure that the unit operates properly during the startup operation.

Instruct the customer on how to operate and maintain the unit. Inform customers that they should store this Installation Manual with the Operation Manual and General Safety Considerations for future reference.

Always use a licensed installer or contractor to install this unit. Improper installation can result in water or refrigerant leakage, electric shock, fire or explosion.

Meanings of **DANGER, WARNING, CAUTION, and NOTE** Symbols:

-  **DANGER**Indicates an imminently hazardous situation which, if not avoided, will result in death or serious injury.
-  **WARNING**Indicates a potentially hazardous situation which, if not avoided, could result in death or serious injury.
-  **CAUTION**Indicates a potentially hazardous situation which, if not avoided, may result in minor or moderate injury. It may also be used to alert against unsafe practices.
-  **NOTE**Indicates situations that may result in equipment or property damage accidents only.

DANGER

- Refrigerant gas is heavier than air and replaces oxygen. A massive leak can lead to oxygen depletion, especially in basements, and an asphyxiation hazard could occur leading to serious injury or death.
- Do not ground units to water pipes, gas pipes, telephone wires, or lightning rods as incomplete grounding can cause a severe shock hazard resulting in severe injury or death. Additionally, grounding to gas pipes could cause a gas leak and potential explosion causing severe injury or death.
- If refrigerant gas leaks during installation, ventilate the area immediately. Refrigerant gas may produce toxic gas if it comes in contact with fire. Exposure to this gas could cause severe injury or death.
- After completing the installation work, check that the refrigerant gas does not leak throughout the system.
- Do not install unit in an area where flammable materials are present due to risk of explosions that can cause serious injury or death.
- Safely dispose of all packing and transportation materials in accordance with federal/state/local laws or ordinances. Packing materials such as nails and other metal or wood parts, including plastic packing materials used for transportation may cause injury or death by suffocation.

WARNING

- Only qualified personnel must carry out the installation work. Installation must be done in accordance with this installation manual. Improper installation may result in water leakage, electric shock or fire.
- When installing the unit in a small room, take measures to keep the refrigerant concentration from exceeding allowable safety limits. Excessive refrigerant leaks, in the event of an accident in a closed ambient space, can lead to oxygen deficiency.
- Use only specified accessories and parts for installation work. Failure to use specified parts may result in water leakage, electric shock, fire or the unit falling.
- Install the air conditioner or heat pump on a foundation strong enough that it can withstand the weight of the unit. A foundation of insufficient strength may result in the unit falling and causing injury.
- Take into account strong winds, typhoons, or earthquakes when installing. Improper installation may result in the unit falling and causing accidents.
- Make sure that a separate power supply circuit is provided for this unit and that all electrical work is carried out by qualified personnel according to local, state and national regulations. An insufficient power supply capacity or improper electrical construction may lead to electric shock or fire.
- Make sure that all wiring is secured, that specified wires are used, and that no external forces act on the terminal connections or wires. Improper connections or installation may result in fire.
- When wiring, position the wires so that the control box cover can be securely fastened. Improper positioning of the control box cover may result in electric shock, fire or the terminals overheating.
- Before touching electrical parts, turn off the unit.
- Do not use means to accelerate the defrosting process or to clean, other than those recommended by the manufacturer.
- The appliance shall be stored in a room without continuously operating ignition sources (for example: open flames, an operating gas appliance or an operating electric heater).
- Do not pierce or burn.
- Be aware that refrigerants may not contain an odor.

- Comply with national gas regulations.
- This equipment can be installed with a Ground-Fault Circuit Interrupter (GFCI). Although this is a recognized measure for additional protection, with the grounding system in North America, a dedicated GFCI is not necessary.
- When installing or relocating the system, keep the refrigerant circuit free from substances other than the specified refrigerant (R32) such as air. Any presence of air or other foreign substance in the refrigerant circuit can cause an abnormal pressure rise or rupture, resulting in injury.
- Do not change the setting of the protection devices. If the pressure switch, thermal switch, or other protection device is shorted and operated forcibly, or parts other than those specified by Daikin are used, fire or explosion may occur.
- Do not install in a wet room such as a bathroom or laundry room due to a risk of fire or electric shock.
- That pipe-work including piping material, pipe routing, and installation shall include protection from physical damage in operation and service, and be in compliance with national and local codes and standards, such as ASHRAE 15, ASHRAE 15.2, IAPMO Uniform Mechanical Code, ICC International Mechanical Code, or CSA B52. All field joints shall be accessible for inspection prior to being covered or enclosed;

CAUTION

- Do not touch the switch with wet fingers. Touching a switch with wet fingers can cause electric shock.
- Do not allow children to play on or around the unit to prevent injury.
- Do not touch the refrigerant pipes during and immediately after operation as the refrigerant pipes may be hot or cold, depending on the condition of the refrigerant flowing through the refrigerant piping, compressor, and other refrigerant cycle parts. Your hands may suffer burns or frostbite if you touch the refrigerant pipes. To avoid injury, give the pipes time to return to normal temperature or, if you must touch them, be sure to wear proper gloves.
- The heat exchanger fins are sharp enough to cut. To avoid injury wear gloves or cover the fins when working around them.
- Install drain piping to proper drainage. Improper drain piping may result in water leakage and property damage.
- Insulate piping to prevent condensation.
- Be careful when transporting the unit.
- Do not turn off the power supply immediately after stopping operation. Always wait for at least 5 minutes before turning off the power supply. Otherwise, water leakage may occur.
- Do not use a charging cylinder. Using a charging cylinder may cause the refrigerant to deteriorate.
- Refrigerant R32 in the system must be kept clean, dry, and tight.
 - (a) Clean and Dry - Foreign materials (including mineral oils such as SUNISO oil or moisture) should be prevented from getting into the system.
 - (b) Tight - R32 does not contain any chlorine, does not destroy the ozone layer, and does not reduce the earth's protection against harmful ultraviolet radiation. R32 can contribute to the greenhouse effect if it is released. Therefore take proper measures to check for the tightness of the refrigerant piping installation. Read the chapter Refrigerant Piping Work and follow the procedures.
- The indoor unit is for R32. See the catalog for indoor models that can be connected. Normal operation is not possible when connected to other units.
- Indoor units are for indoor installation only. Outdoor units can be installed either outdoors or indoors.

- Do not install the air conditioner or heat pump in the following locations:
 - (a) Where a mineral oil mist or oil spray or vapor is produced, for example, in a kitchen.
Plastic parts may deteriorate and fall off or result in water leakage.
 - (b) Where corrosive gas, such as sulfurous acid gas, is produced.
Corroding copper pipes or soldered parts may result in refrigerant leakage.
 - (c) Near machinery emitting electromagnetic waves.
Electromagnetic waves may disturb the operation of the control system and cause the unit to malfunction.
 - (d) Where flammable gas may leak, where there is carbon fiber, or ignitable dust suspension in the air, or where volatile flammables such as thinner or gasoline are handled. Operating the unit in such conditions can cause fire.

NOTE

- Install the power supply and transmission wires for the indoor and outdoor units at least 3.5 ft. (1 m) away from televisions or radios to prevent image interference or noise. Depending on the radio waves, a distance of 3.5 ft. (1 m) may not be sufficient to eliminate the noise.
 - Dismantling the unit, treatment of the refrigerant, oil and additional parts must be done in accordance with the relevant local, state, and national regulations.
 - Only use tools for R32, such as a gauge manifold, charge hose, gas leak detector, reverse flow check valve, refrigerant charge base, vacuum gauge, or refrigerant recovery equipment.
 - If the conventional refrigerant and refrigerator oil are mixed in R32, the refrigerant may deteriorate.
 - This air conditioner or heat pump is an appliance that should not be accessible to the general public.
 - As design pressure is 580 psi (4.0 MPa), the wall thickness of field-installed pipes should be selected in accordance with the relevant local, state, and national regulations.
 - A refrigerant sensor is mounted in the indoor units. Do not use gas appliances using flammable gas (propane, butane, methane, etc.), sprays using flammable gas (LPG, etc.) such as insecticide or hair spray, smoke, medical agent and paint in the vicinity. If it reacts, a malfunction code is displayed and the operation may not be able to be performed.
 - Once the refrigerant sensor reacts, it needs to be replaced with a new one.
-





2. BEFORE INSTALLATION



When unpacking the indoor unit or moving the unit after unpacked, hold the hanger brackets (4 locations) and do not apply force to other parts (particularly refrigerant piping, drain piping).



- Make sure to check in advance that the refrigerant to be used for installation work is R32.
(The air conditioner will not properly operate if a wrong refrigerant is used.)
- For installation of the outdoor unit and additional refrigerant charge, refer to the installation manual attached to the outdoor unit.
- Do not throw away the accessories until the installation work is completed.
- Do not damage the equipment or property when carrying the indoor unit into the room.
 - (1) Measure the unit with packaging to ensure the unit can be carried safely while still packaged.
 - (2) Determine the route to carry the unit into the room.
 - (3) Do not unpack the unit until it is carried to the installation location.
Where unpacking is unavoidable, use a sling of soft material or protective plates together with a rope when lifting, to avoid damage or scratches to the indoor unit.
- After the indoor unit is carried into the room, to avoid the indoor unit from getting damaged, take measures to protect the indoor unit with packing materials.
- Have the customer actually operate the air conditioner while looking at the operation manual.
Instruct the customer how to operate the air conditioner (particularly cleaning of the air filters, operation procedures, and temperature adjustment).
- Do not use the air conditioner in a salty atmosphere such as coastal areas, vehicles, vessels or where voltage fluctuation is frequent such as factories.
- Take off static electricity from the body when carrying out wiring and the control box cover is removed.
The electric parts may be damaged.

2-1 ACCESSORIES

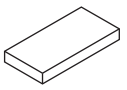
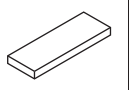
Check if the following accessories are attached to the indoor unit.

Name	(1) Metal clamp	(2) Drain hose	(3) Duct flange connection screw	
Quantity	1 pc.	1 pc.	See below	
Shape				18 pcs.
				30 pcs.

Name	Joint insulating material	(6) Sealing material	(7) Sealing material	(8) Clamp
Quantity	1 each	1 sheet	2 sheets	8 pcs.
Shape	 (4) For liquid piping	 Large (Dark gray)	 Medium (Dark gray)	
	 (5) For gas piping			

Name	(9) Washer clamp	(10) Wire sealing material	(11) Washer for hanger bracket
Quantity	4 pcs.	2 sheets	8 pcs.
Shape		 Small (Gray)	

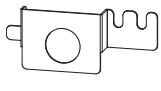
Name	(12) Conduit mounting plate	Others
Quantity	1 pc.	<ul style="list-style-type: none"> • Operation manual • Operation manual (Regarding copyright) • Installation manual • Warranty card
Shape		

2-2 OPTIONAL ACCESSORIES

- **A remote controller is required for the indoor unit.**
Install the remote controller to the place where the customer has given consent.
Refer to the catalog for the applicable model.
(Refer to the installation manual attached to the remote controller for how to install.)
- **The indoor unit can be switched to lower suction. (Refer to 4. PREPARATION BEFORE INSTALLATION.)**
The side cover plate (KDBD63A160) is required in the case of wiring from the bottom surface at bottom suction.
For installation work, refer to the installation manual provided with the side cover plate.

CARRY OUT THE WORK GIVING CAUTION TO THE FOLLOWING ITEMS AND AFTER THE WORK IS COMPLETED CHECK THESE AGAIN.

(1) Items to be checked after the installation work is completed

Items to be checked	In case of defective	Check column
Are the indoor and outdoor units rigidly fixed?	Drop · vibration · noise	
Are the installation works of the outdoor and indoor units completed?	Does not operate · burnout	
Have you carried out air tight test with the test pressure specified in the outdoor unit installation manual?	Does not cool/ Does not heat	
Is the insulation of refrigerant piping and drain piping completely carried out?	Water leakage	
Does the drain flow out smoothly?	Water leakage	
Is the power supply voltage identical to that stated on the name plate of the air conditioner?	Does not operate · burnout	
Are you sure that there is no wrong wiring or piping or no loose wiring?	Does not operate · burnout	

Items to be checked	In case of defective	Check column
Is grounding completed?	Danger in case of leakage	
Are the sizes of electric wiring according to the specification?	Does not operate · burnout	
Is any of discharge or suction of the indoor and outdoor units blocked with obstacles? (It may lead to capacity drop due to fan speed drop or malfunction of equipment.)	Does not cool/ Does not heat	
Is the external static pressure set correctly?	Does not cool/ Does not heat	
Have you recorded the refrigerant piping length and the refrigerant charge amount added?	Refrigerant charge amount is not clear	

Make sure to recheck the items of "SAFETY CONSIDERATIONS".

(2) Items to be checked at delivery

Items to be checked	Check column
Have you carried out field setting? (if necessary)	
Are the control box cover, the air filter and the suction grille attached?	
Does the cool air discharge during the cooling operation and the warm air discharge during the heating operation? Does the indoor unit makes unpleasant sound of air discharge?	
Have you explained how to operate the air conditioner showing the operation manual to the customer?	
Have you explained the description of cooling, heating, program dry and automatic (cooling/heating) given in the operation manual to the customer?	
If you set the fan speed at thermostat OFF, did you explain the set fan speed to the customer.	
Have you handed the operation manual and the installation manual to the customer?	
Have you checked that there is no generation of abnormal noise (i.e., noise resulting from contamination or missing parts)?	
If an optional accessory is in use, did you check the operation of the optional accessory and make field settings as needed?	
Is the remote controller icon displayed? Is the remote controller connected to the master unit if the system is in simultaneous multi operation?	
Have you explained failure examples of	
3. SELECTION OF INSTALLATION LOCATION?	

Points of the operation explanation

In addition to the general usage, since the items in the operation manual with the **⚠ WARNING** and **⚠ CAUTION** marks are likely to result in human bodily injuries and property damages, it is necessary not only to explain these items to the customer but also to have the customer read them.
Furthermore, it is necessary to have the customer read through the troubleshooting items while explaining the above items.

3. SELECTION OF INSTALLATION LOCATION

R32 refrigerant is a mildly flammable refrigerant. Do not install indoor or outdoor units in areas where, in the event of a refrigerant leakage, refrigerant concentrations could exceed flammable concentrations.

Hold the hanger brackets at 4 locations to move the indoor unit when unpacking or after unpacked, and do not apply force to the piping (refrigerant and drain) and discharge flange.

If the temperature and humidity in the ceiling is likely to exceed 86°F (30°C), RH80%, use the additional insulation stick to the indoor unit (Field supply).

Use the insulation such as glass wool or polyethylene that has thickness of 3/8 in. (10 mm) or more. However, keep the insulated outside dimension smaller than the ceiling opening so that the unit may go through the opening at installation.

(1) Select the installation location that meets the following conditions and get approval of the customer.

- Where the cool and warm air spreads evenly in the room.
- Where there are no obstacles in the air passage.
- Where drainage can be ensured.
- Where the ceiling's lower surface is not remarkably inclined.
- Where there is sufficient strength to withstand the weight of the indoor unit. (If the strength is insufficient, the indoor unit may vibrate and get in contact with the ceiling and generate unpleasant chattering noise.)
- Where a space sufficient for installation and service can be ensured. **(Refer to Fig. 1 and Fig. 2)**
- Where the piping length between the indoor and the outdoor units is ensured within the allowable length. (Refer to the installation manual attached to the outdoor unit.)
- Where there is no risk of flammable gas leak.

[Required installation space [in. (mm)]]
 Figures indicate the minimum required installation space.

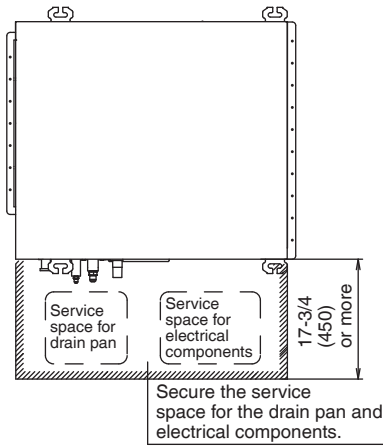

Fig. 1

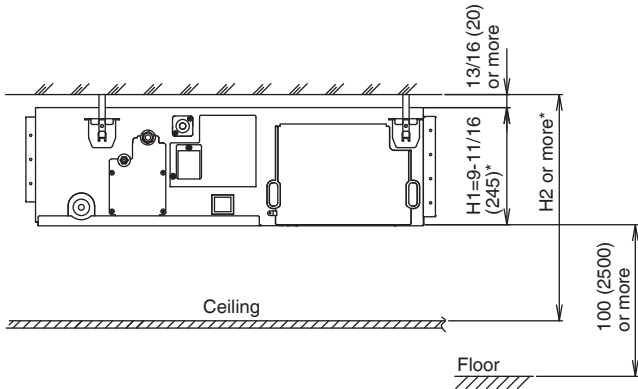

Fig. 2

- * Dimension H1 indicates the unit height.
- * Secure a downward slope of at least 1/100 specified in 7. DRAIN PIPING WORK and determine dimension H2.

<Failure example>

If there is an obstacle in the airflow path or proper installation space is not provided, the indoor unit will cause air volume reduction and take in air blown out of the indoor unit, thus resulting in performance degradation or turning the thermostat OFF frequently.

CAUTION

Install the indoor and outdoor units, power supply wiring, remote controller wiring and transmission wiring at least 3.5 ft. (1 m) away from televisions or radios to prevent image interference or noise.
 (Depending on the radio waves, a distance of 3.5 ft. (1 m) may not be sufficient to eliminate the noise.)

(2) Use suspension bolts for installation.

Investigate if the installation place can withstand the weight of the indoor unit and, if necessary, hang the indoor unit with bolts after it is reinforced by beams etc.

4. PREPARATION BEFORE INSTALLATION

(1) Check the relation of location between the ceiling opening and the indoor unit suspension bolts.

- Provide one of the following service spaces for the maintenance and inspection of the control box and drain pump or for other services.
 - Inspection hatches 1 and 2 17-3/4x17-3/4 in. (450x450 mm) (Fig. 3-1) and a minimum space of 11-13/16 in. (300 mm) at the bottom of the unit (Fig. 3).
 - Inspection hatch 1 17-3/4x17-3/4 in. (450x450 mm) on the control box side and inspection hatch 2 on the bottom of the unit. (Fig. 4, arrow A-1)
 - Inspection hatch 3 on the bottom of the unit and on the bottom side of the control box. (Fig. 4, arrow A-2)

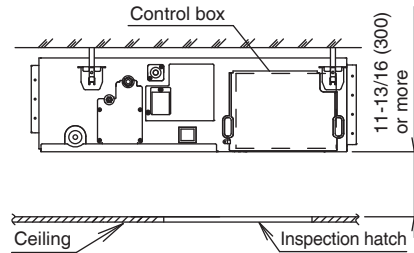

< In the case of (1)-1 >

Fig. 3

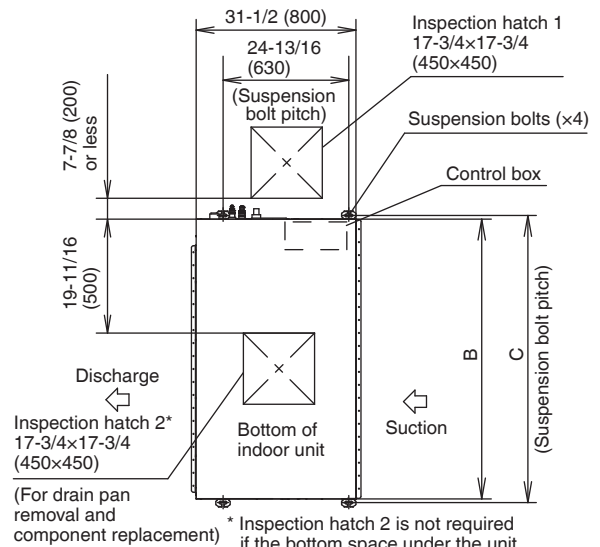

Fig. 3-1

* Inspection hatch 2 is not required if the bottom space under the unit is accessible for work.

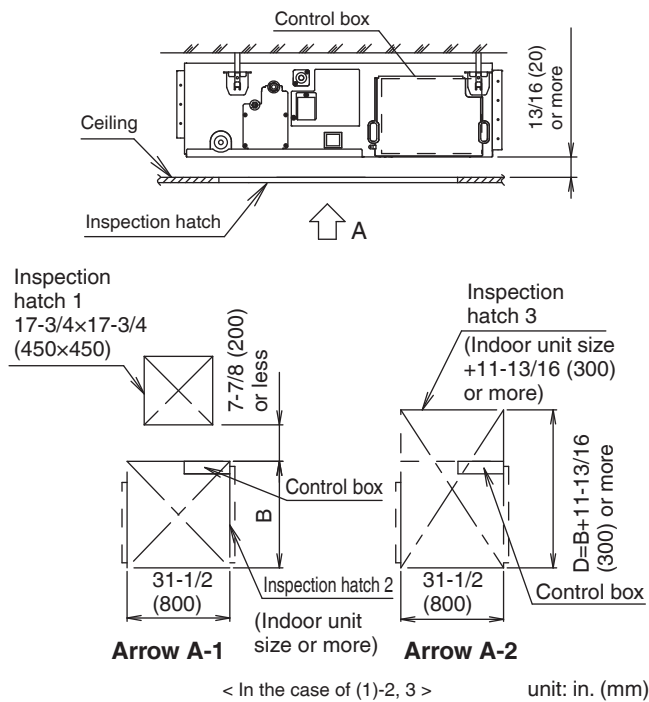

Fig. 4

Table 1 (unit [in. (mm)])

Model	B	C	D
18-24 type	39-3/8 (1000)	40-7/8 (1038)	51-3/16 (1300)
30-36-42-48 type	55-1/8 (1400)	56-5/8 (1438)	66-15/16 (1700)

- (2) **Mount canvas ducts to the discharge and suction so that the vibration of the indoor unit will not be transmitted to the ducts or ceiling. Furthermore, attach sound absorbing material (thermal insulation material) to the duct inner walls and anti-vibration rubber to the suspension bolts (refer to 8. DUCT WORK).**
- (3) **The indoor unit is set to standard external static pressure.**
- If external static pressure is higher or lower than the standard set value, the remote controller may be used to make field setting change in the external static pressure. Refer to **10. FIELD SETTING**.
- (4) **Open installation holes (in the case of installation onto the existing ceiling).**
- Open the installation holes on the ceiling of the installation location, and work on the refrigerant piping, drain piping, remote controller wiring and wiring between the indoor and outdoor units to the piping connection port and wiring connection port of the indoor unit (refer to each piping and wiring procedure items).
 - Ceiling framework reinforcement may be required in order to keep the ceiling horizontal and prevent ceiling vibration after opening the ceiling holes. For details, consult your building and interior work contractors.

(5) Install the suspension bolts.

- Use either a M8-M10 size bolt or equivalent. Use hole-in-anchors for the existing bolts and embedded inserts or foundation bolts for new bolts, and fix the indoor unit firmly to the building so that it may withstand the weight of the unit. In addition, adjust clearance (2-4 in. (50-100 mm)) from the ceiling in advance.

<Installation examples>

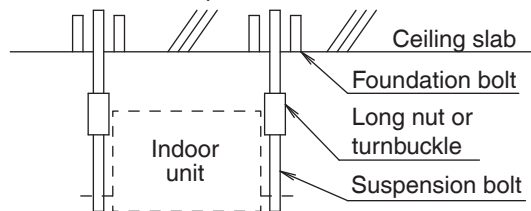

Note) Components shown in the figure above are all local procurement.

(6) In the case of changing the preset suction to bottom suction, replace the chamber cover and the suction flange. (Refer to Fig. 5)

1. Remove the suction flange and chamber cover.
2. Replace the suction flange and the chamber cover.

⚠ CAUTION

- Secure a sufficient service space for the drain pan and electrical components before installing the indoor unit.
- Secure a sufficient service space for the filter chamber, and peripheral components before installing the indoor unit.

<18-48 type>

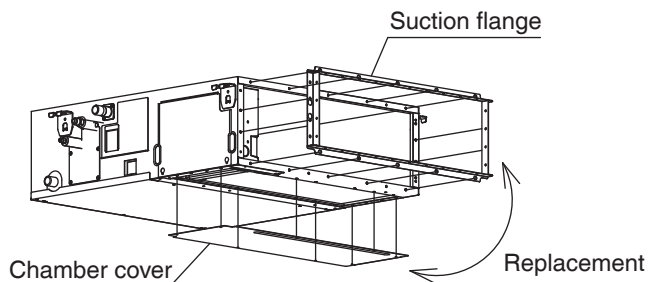

Note)

1. Be sure to remove chamber cover one side by one side.
2. For this model, maintenance of the control box through side is only available. Maintenance through bottom is not available.

Fig. 5

5. INSTALLATION OF INDOOR UNIT

Depending on the optional accessories, it may be easier to attach them before installing the indoor unit. Refer to also the installation manual attached to the optional accessories.

For installation, use the attached and specified accessories.

(1) Install the indoor unit temporarily.

- Fix the hanger bracket to the suspension bolt. Make sure to securely fix the hanger bracket with the nut and the washer for hanger bracket (11) from the upper and lower side. (Refer to Fig. 6)

If the washer clamp (9) is used, the upper side washer for hanger bracket (11) may be protected from falling off. (Refer to Fig. 7)

[Fix the hanger bracket]

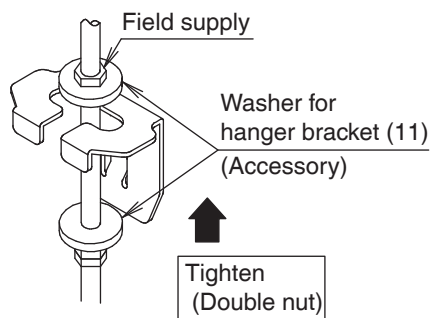

Fig. 6

[Washer fixing]

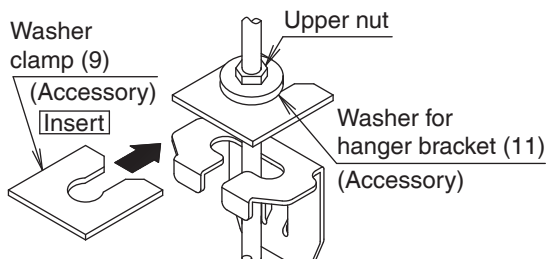

Fig. 7

- Keep the discharge covered with a protective sheet to prevent weld spatter and other foreign materials from entering the indoor unit and damaging the resin drain pan. (If holes or cracks are generated in the resin drain pan, water can leak.)

(2) Adjust so that the unit is properly positioned.

(3) Check the level of the unit. (Refer to Fig. 8)

(4) Remove the washer clamp (9) used for preventing the washer for hanger bracket (11) from dropping and tighten the upper side nut.

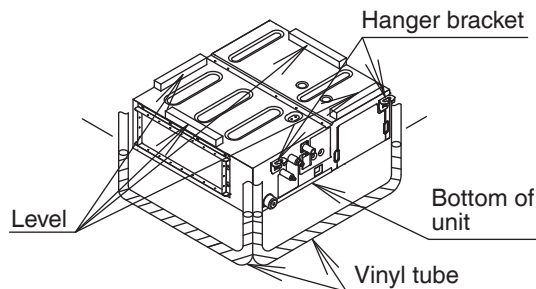

Feed water into the tube and set the indoor unit to the water levels on the left and right.

[Maintaining horizontality]

Fig. 8

⚠ CAUTION

- **Install the indoor unit leveled.**

If the indoor unit is inclined and the drain piping side gets high, it may cause malfunction of float switch and result in water leakage.

- **Attach nuts on the upper and lower side of hanger bracket.**

If there is no upper nut and the lower nut is over-tightened, the hanger bracket and the top plate will deform and cause abnormal sound.

- **Do not insert materials other than that specified into the clearance between the hanger bracket and the washer for hanger bracket (11).**

Unless the washers are properly attached, the suspension bolts may come off from the hanger bracket.

⚠ WARNING

The indoor unit must be securely installed on a place that can withstand the weight.

If the strength is insufficient, the indoor unit may fall down and cause injuries.

6. REFRIGERANT PIPING WORK

- For the outdoor unit refrigerant piping, refer to the installation manual attached to the outdoor unit.
- Carry out insulation of both gas and liquid refrigerant piping securely. If not insulated, it may cause water leakage. For gas piping, use insulation material of which heat resistant temperature is not less than 250°F (120°C). For use under high humidity, strengthen the insulation material for refrigerant piping. If not strengthened, the surface of insulation material may sweat.
- Before installation work, make sure that the refrigerant is R32. (Unless the refrigerant is R32, the normal operation cannot be expected.)

CAUTION

This air conditioner is a dedicated model for refrigerant R32. Make sure to meet the requirements shown below and carry out installation work.

- Use dedicated piping cutters and flaring tools for R32.
- When making a flare connection, coat the flared inner surface only with ether oil or ester oil.
- Use only the flare nuts attached to the air conditioner. If other flare nuts are used, it may cause refrigerant leakage.
- To prevent contamination or moisture from getting into the piping, take measures such as pinching or taping the piping.

Do not mix substance other than the specified refrigerant such as air into the refrigeration circuit. If the refrigerant leaks during the work, ventilate the room.

Maintain good ventilation while carrying out work and ensure that there are no open flames in the vicinity.

- The refrigerant is pre-charged in the outdoor unit.
- When connecting the piping to the air conditioner, make sure to use a spanner and a torque wrench as shown in Fig. 9.
- For the dimension of flared part and the tightening torque, refer to the Table 2.
- When making a flare connection, coat the flared inner surface only with ether oil or ester oil.

(Refer to Fig. 10)

Then, turn the flare nut 3 to 4 times with your hand and screw in the nut.

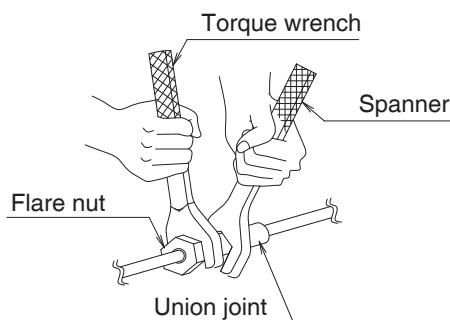

Fig. 9

Coat the flared inner surface only with ether oil or ester oil

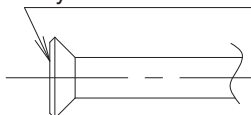

Fig. 10

Table 2

Piping size [in. (mm)]	Tightening torque [lbf-ft. (N·m)]	Dimension for processing flare A [in. (mm)]	Flare shape [in. (mm)]
φ 3/8 (9.5)	24.1–29.4 (36.3±3.6)	0.504–0.520 (13.0±0.2)	
φ 5/8 (15.9)	45.6–55.6 (68.6±6.8)	0.760–0.776 (19.5±0.2)	

CAUTION

Do not have oil adhere to the screw fixing part of resin parts.

If oil adheres, it may weaken the strength of screwed part.

Do not tighten flare nuts too tight.

If a flare nut cracks, the refrigerant may leak.

- If there is no torque wrench, use Table 3 as a rule of thumb. When tightening a flare nut with a spanner harder and harder, there is a point where the tightening torque suddenly increases. From that position, tighten the nut additionally at the angle shown in Table 3. After the work is finished, check securely that there is no gas leak. If the nut is not tightened as instructed, it may cause slow refrigerant leak and result in malfunction (such as does not cool or heat).

Table 3

Piping size [in. (mm)]	Tightening angle	Recommended arm length of tool used [in. (mm)]
φ 3/8 (9.5)	60°–90°	Approx. 8 (200)
φ 5/8 (15.9)	30°–60°	Approx. 12 (300)

CAUTION

Insulation of field piping must be carried out up to the connection inside the casing.

If the piping is exposed to the atmosphere, it may cause sweating, burn due to touching the piping, electric shock or fire due to the wiring touching the piping.

- After leak test, referring to **Fig. 11**, insulate both the gas and liquid piping connection with the attached joint insulating material (4) and (5) to prevent the piping from getting exposed. Then, tighten both the ends of insulating material with the clamp (8).
- Wrap the sealing material (Medium) (7) around the joint insulating material (4) and (5) (flare nut section), both the gas and liquid piping.
- Make sure to bring the seam of joint insulating material (4) and (5) to the top.

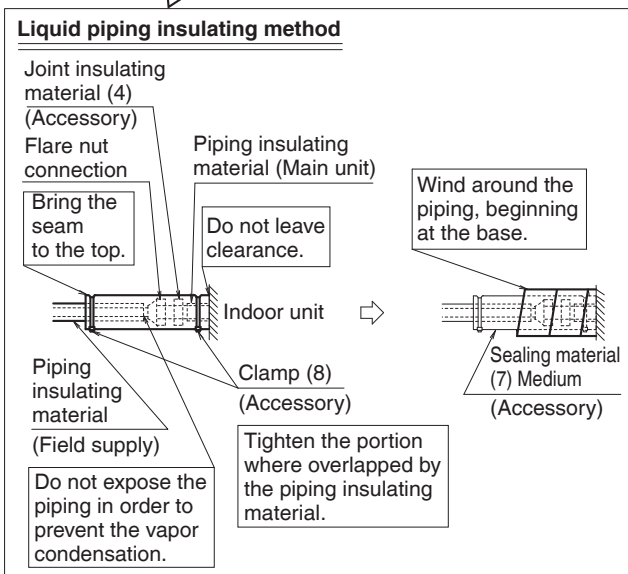
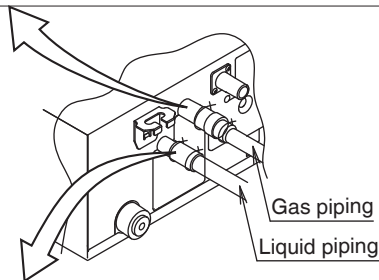
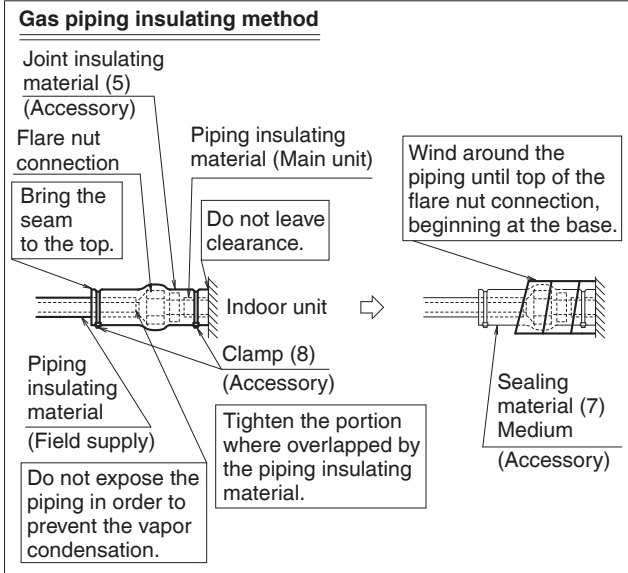

Fig. 11

- Before brazing refrigerant piping, have nitrogen flow through the refrigerant piping and substitute air with nitrogen (NOTE 1) (**Refer to Fig. 12**). Then, carry out brazing (NOTE 2). After all the brazing works are finished, carry out flare connection with the indoor unit. (**Refer to Fig. 11**)

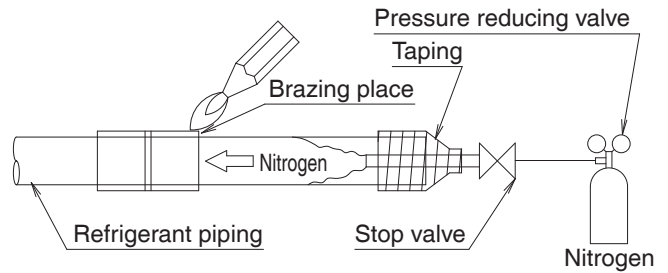

Fig. 12

CAUTION

- Nitrogen, not R32 refrigerant gas, must be used for gas displacement in the piping before brazing work. (Non-compliance may result in fire.)
- When using a brazing torch, check that there are no refrigerant leaks using a refrigerant leak detector.
- In the event of a refrigerant leakage during brazing work, immediately turn off the torch and any other sources of fire.

NOTE

1. The proper pressure for having nitrogen flow through the piping is approximately 2.9 psi (0.02 MPa), a pressure that makes one feel like slight breeze and can be obtained through a pressure reducing valve.
2. Do not use flux when brazing refrigerant piping. Use phosphor copper brazing filler metal (BCuP-2/ B-Cu93P-710/795: ISO 3677) that does not require flux. (If chlorinated flux is used, the piping will be corroded and, in addition if fluorine is contained, the refrigerant oil will be deteriorated and the refrigerant circuit will be affected badly.)
3. When carrying out air tight test of refrigerant piping and the indoor unit after the installation of indoor unit is finished, confirm the connecting outdoor unit installation manual for test pressure. Refer to also the outdoor unit installation manual or technical document for refrigerant piping.
4. In case of refrigerant shortage due to forgetting additional refrigerant charge etc., it will result in malfunction such as does not cool or does not heat. Refer to the outdoor unit installation manual or technical document for refrigerant piping.

CAUTION

Do not use antioxidant when brazing piping. It may result in malfunction of components and clogging of piping due to residue.

7. DRAIN PIPING WORK

(1) Carry out drain piping.

Carry out drain piping so that drainage is ensured.

- Select the piping diameter equal to or larger than (except for riser) that of the connection piping (polyvinyl chloride piping, nominal diameter 1 in. (25 mm), outside diameter 1-1/4 in. (32 mm)).
- Install the drain piping as short as possible with downward inclination of 1/100 or more and without such that air may not stagnate. (Refer to Fig. 13) (It may cause abnormal sound such as bubbling noise.)

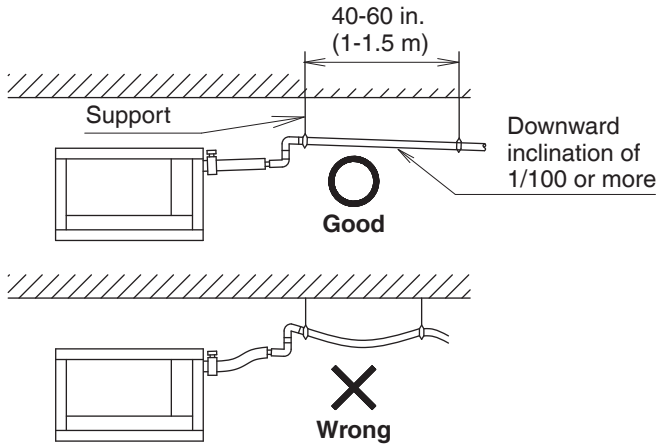

Fig. 13

CAUTION

If drain stagnates in the drain piping, the piping may be clogged.

- If sufficient downward inclination cannot be ensured, carry out upward drain piping.
- Install supports at a distance of 40-60 in. (1 to 1.5 m) so that the piping may not deflect. (Refer to Fig. 13)
- Make sure to use the attached drain hose (2) and the metal clamp (1).
Insert the drain hose (2) into the drain socket up to the point where the socket diameter becomes larger.
Put the metal clamp (1) to the taped hose end and tighten the metal clamp (1) with torque 0.9-1.1 lbf-ft. (1.2-1.5 N·m).

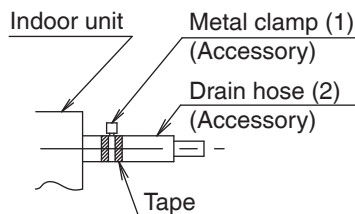

Fig. 14

CAUTION

- Do not tighten the metal clamp (1) with the torque more than the specified value.
The drain hose (2), the socket or the metal clamp (1) may be damaged.

- Wrap the vinyl tape around the end of the metal clamp (1) so that the sealing material (Large) (6) to be used at the next process may not be damaged with the clamp end or bend the tip of the metal clamp (1) inward as shown. (Refer to Fig. 15)

<In case of sticking vinyl tape>

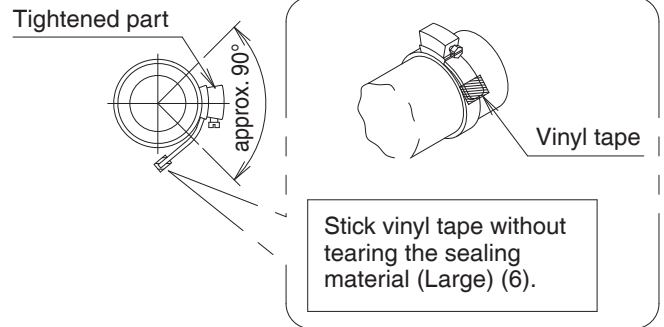

<In case of bending the tip>

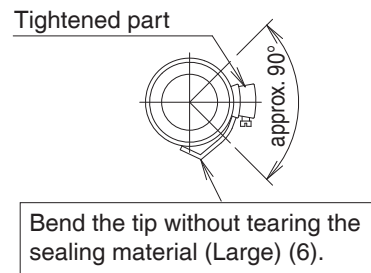

Fig. 15

< Caution to be taken when carrying out upward drain piping (Refer to Fig. 16) >

- The maximum height of the drain riser is 26-9/16 in. (675 mm). Since the drain pump mounted on this indoor unit is a high head type, from the characteristic point of view, the higher the drain riser the lower the draining noise. Therefore, the drain riser of 11-13/16 in. (300 mm) or higher is recommended.
- For upward drain piping, keep the horizontal piping distance of 11-13/16 in. (300 mm) or less between the drain socket root to the drain riser.

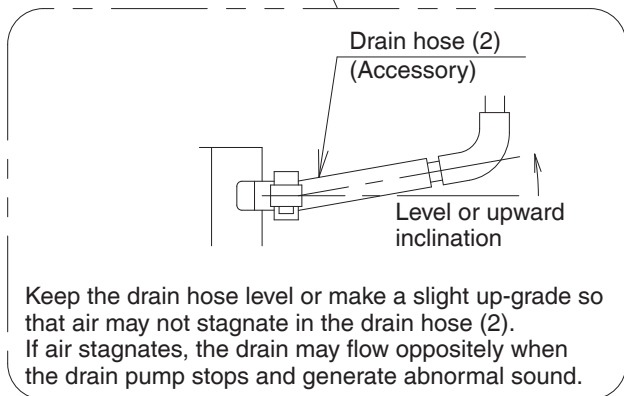
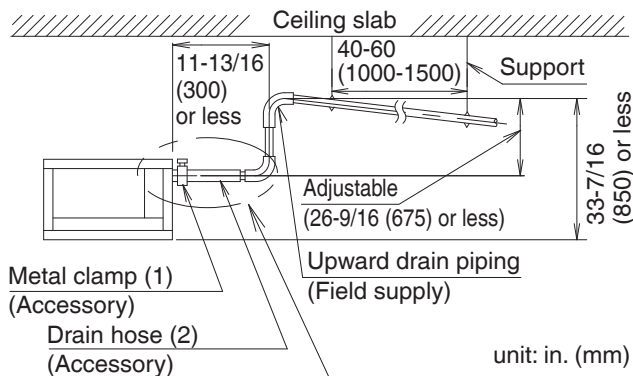

Fig. 16

CAUTION

- To avoid the attached drain hose (2) getting excessive force, do not bend nor twist it. It may cause water leakage.
- As for drain piping connection, do not connect the drain hose directly to a sewage that gives off ammonia odor. (The ammonia in the sewage may go through the drain piping and corrode the heat exchanger of the indoor unit.)
- In case of centralized drain piping, carry out piping work according to the procedure shown in the following Fig. 17.

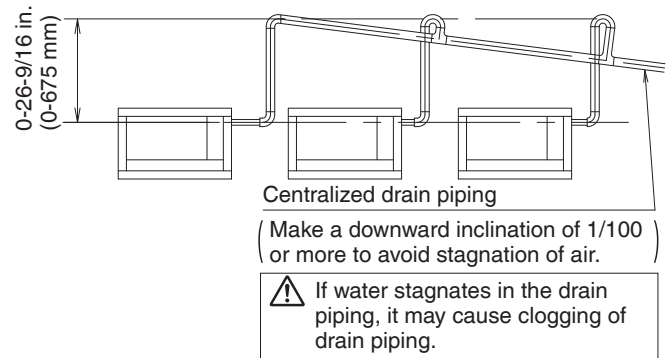

Fig. 17

- As for the size of centralized drain piping, select the size that meets the capacity of indoor units to be connected. (Refer to the technical document.)
- Positioning the upward drain piping at an angle may cause float switch malfunction and lead to water leakage.
- While replacing with new indoor unit, use the attached new drain hose (2) and the metal clamp (1). If an old drain hose or a metal clamp is used, it may cause water leakage.

(2) After piping is finished, check if the drain flows smoothly.

[When the electric wiring work is finished]

- Gradually pour 1/4 gal. (1 ℓ) of water from the filling port at the bottom of the drain socket or the discharge into the drain pan, and be careful spraying water to the electric components such as drain pump and confirm drainage by operating the indoor unit under cooling mode according to **10. FIELD SETTING. (Refer to Fig. 18)**

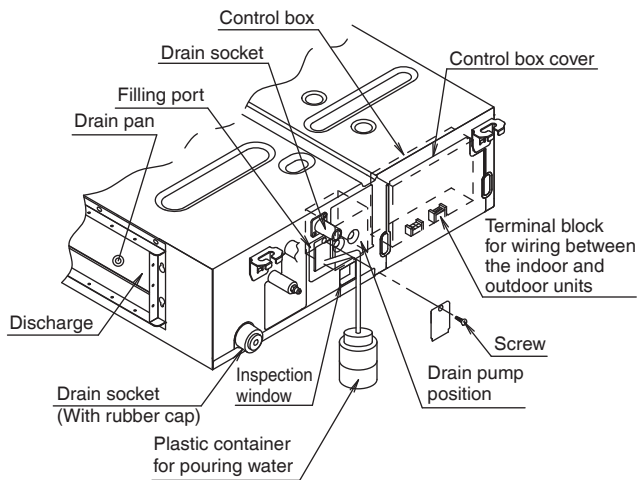

[Method of adding water]
Fig. 18

[When the electric wiring work is not finished]

- The electric wiring works (including grounding) must be carried out by a qualified electrician.
- If a qualified person is not present, after the electric wiring work is finished, check the drainage according to the method specified in **[When the electric wiring work is finished]**.
 1. Open the control box cover and connect the single phase 208/230 V power supply to the terminal (L1, L2) on the terminal block (X2M). Connect the ground wiring to the ground terminal.
 2. Make sure the control box cover is closed before turning on the power supply.
 - Throughout the whole process, carry out the work giving caution to the wiring around the control box so that the connectors may not come off.
 3. Gradually pour 1/4 gal. (1 ℓ) of water from the discharge into the drain pan, and be careful spraying water to the electric components such as drain pump. **(Refer to Fig. 18)**
 4. When the power supply is turned on, the drain pump will operate. Drainage can be checked at the transparent part of the drain socket. (The drain pump will automatically stop after 10 minutes.)
The drainage of water can be confirmed with water level change in the drain pan through the access window.
 - Do not connect the drain piping directly to the sewage that gives off ammonia odor. The ammonia in the sewage may go through the drain piping and corrode the heat exchanger of the indoor unit.

- Do not apply external force to the float switch. (It may result in malfunction)
 - Do not touch the drain pump.
Touching the drain pump may cause electric shock.
5. Turn off the power supply after checking drainage, and remove the power supply wiring.
 6. Attach the control box cover as before.

(3) Sweating may occur and result in water leakage. Therefore, make sure to insulate the following 2 locations (drain piping that laid indoors and drain sockets).

- Use the provided sealing material (Large) (6), and perform the thermal insulation of the metal clamp (1) and drain hose (2) after checking the drainage of water. **(Refer to Fig. 19)**

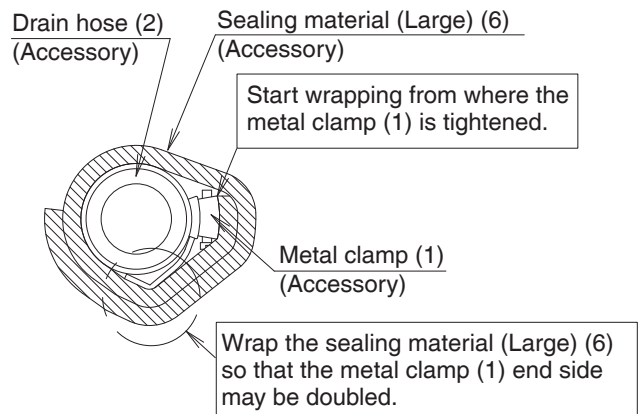
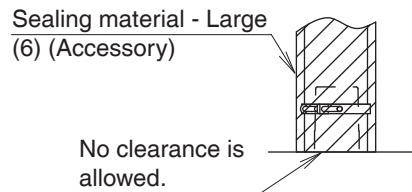

Fig. 19

8. DUCT WORK

Pay the utmost attention to the following items and conduct the duct work.

- Check that the duct is not in excess of the setting range of external static pressure for the unit. (Refer to the technical datasheet for the setting range.)
- Attach a canvas duct each to the discharge and suction so that the vibration of the equipment will not be transmitted to the duct or ceiling.
Use a sound-absorbing material (insulation material) for the lining of the duct and apply vibration insulation rubber to the suspension bolts.
- At the time of duct welding, perform the curing of the duct so that the sputter will not come in contact with the drain pan for the filter.
- If the metal duct passes through a metal lath, wire lath, or plate of a wooden structure, separate the duct and wall electrically.
- Be sure to heat insulate the duct for the prevention of dew condensation. (Material: Glass wool or styrene foam; Thickness: 31/32 in. (25 mm))
- Be sure to attach the field supply air filter to the suction of the unit or field supply suction in the air passage on the suction side. (Be sure to select an air filter with a dust collection efficiency of 50 weight percent.)
- Explain the operation and washing methods of the locally procured components (i.e., the air filter, suction grille, and discharge grille) to the customer.
- Locate the discharge grille on the indoor side for the prevention of drafts in a position where indirect contact with people.
- The air conditioner incorporates a function to adjust the fan to rated speed automatically. **(10. FIELD SETTING)**
Therefore, do not use booster fans midway in the duct.

Connection method of ducts on suction and discharge sides.

- Connect the field supply duct in alignment with the inner side of the flange.
- Connect the flange and unit with the flange connection screw (3).
- Wrap aluminum tape around the flange and duct joint in order to prevent air leakage.

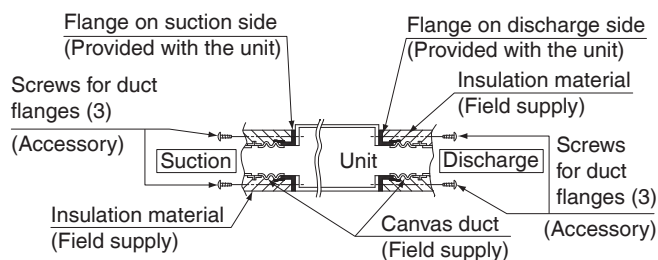

Fig. 20

CAUTION

Connect the flange and unit with the flange connection screw (3) regardless of whether the duct is connected to the suction side.

9. ELECTRIC WIRING WORK

9-1 GENERAL INSTRUCTIONS

- Make certain that all electric wiring work is carried out by qualified personnel according to the applicable legislation and this installation manual, using a separate dedicated circuit.
Insufficient capacity of the power supply circuit or improper electrical construction may lead to electric shock or fire.
- Means for full disconnection under overvoltage category III conditions must be incorporated in the fixed wiring according to national wiring rules.
- Do not turn on the power supply (branch switch, branch over-current circuit breaker) until all the works are finished.
- Make sure to ground the air conditioner.
Grounding resistance should be according to applicable legislation.
- Do not connect the ground wiring to gas or water pipings, lightning conductor or telephone ground wiring.
 - Gas piping Ignition or explosion may occur if the gas leaks.
 - Water piping..... Hard vinyl tubes are not effective grounds.
 - Lightning conductor or telephone ground wiring Electric potential may rise abnormally if struck by a lightning bolt.
- For electric wiring work, refer to also the "WIRING DIAGRAM" attached to the control box cover.
- Carry out wiring between the outdoor units, indoor units and the remote controllers according to the wiring diagram.
- Carry out installation and wiring of the remote controller according to the "installation manual" attached to the remote controller.
- Do not touch the printed circuit board assemblies. It may cause malfunction.

9-2 ELECTRICAL CHARACTERISTICS

Table 4

Units				Power supply		Fan motor	
Model	Hz	Volts	Voltage range	MCA	MOP	HP	IDI
FBA18AAVJU	60	208/230	MAX. 253V MIN. 187V	1.9	15	0.22 (163)	1.5
FBA24AAVJU				1.9	15	0.22 (163)	1.5
FBA30AAVJU				3.0	15	0.52 (390)	2.4
FBA36AAVJU				3.1	15	0.52 (390)	2.5
FBA42AAVJU				3.6	15	0.52 (390)	2.9
FBA48AAVJU				3.6	15	0.52 (390)	2.9

MCA: Minimum Circuit Ampacity (A);

MOP: Maximum Overcurrent Protective Device (A)

HP: Fan Motor Rated Output (Hp (W));

IDI: Inverter Drive Input (A)

9-3 SPECIFICATION FOR FIELD SUPPLY FUSES AND WIRING

Table 5

Model	Power supply wiring		Remote controller wiring Transmission wiring	
	MOP ☐	Size	Wiring	Size
FBA18AAVJU	15A	Wiring size and length must comply with local codes.	2-conductor, stranded nonshielded copper cable PVC/vinyl jacket (NOTE 1)	AWG18-16 (0.75-1.25 mm ²)
FBA24AAVJU				
FBA30AAVJU				
FBA36AAVJU				
FBA42AAVJU				
FBA48AAVJU				

The lengths of remote controller wiring and transmission wiring are as follows:

(1) Remote controller wiring

- Length between indoor unit and remote controller Max. 1,640 ft. (500 m)

(2) Transmission wiring

- Total length Max. 6,560 ft. (2,000 m)
- Length between units Max. 656 ft. (200 m)
- Farthest length*¹ (10 systems*² or less) Max. 3,280 ft. (1,000 m)
- Farthest length*¹ (more than 10 systems*²) Max. 2,296 ft. (700 m)

*¹ Length from outdoor unit to farthest unit

*² System : A set of units connected in the same refrigerant circuit

NOTE

- Vinyl cord with sheath or cable (Insulated thickness : 1/16 in. (1 mm) or more)

9-4 WIRING CONNECTION METHOD

⚠ CAUTION FOR POWER SUPPLY WIRING AND GROUND WIRING

- For connection to the terminal block, use ring type crimp style terminals with insulation sleeve or insulate the wirings properly.

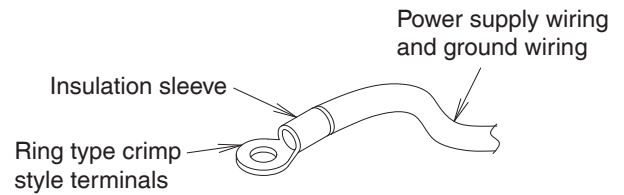

Fig. 21

- Connect the terminal as shown in Fig. 22.
- Do not carry out soldering finish when stranded wires are used. (Otherwise, the loosening of wires may result in abnormal heat radiation.)

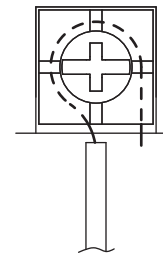

Fig. 22

(Abnormal heating may occur if the wirings are not tightened securely.)

- Use the required wirings, connect them securely and fix these wirings securely so that external force may not apply to the terminals.
- Use a proper screw driver for tightening the terminal screws. If an improper screw driver is used, it may damage the screw head and a proper tightening cannot be carried out.
- If a terminal is over tightened, it may be damaged. Refer to the table shown below for tightening torque of terminals.

Table 6

	Tightening torque [lbf.ft. (N·m)]
Terminal for remote controller and transmission wirings	0.65 ± 0.07 (0.88 ± 0.08)
Terminal for power supply	1.08 ± 0.10
Ground terminal	(1.47 ± 0.14)

- Do not carry out soldering finish when stranded wirings are used.

⚠ WARNING

- When wiring, form the wirings orderly so that the control box cover can be securely fastened. If the control box cover is not in place, the wirings may come out or be sandwiched by the box and the cover and cause electric shock or fire.

(1) Remove the control box cover.

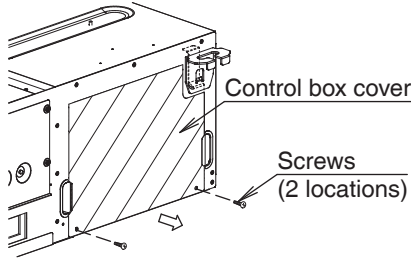

Fig. 23

(2) Attach the conduit to the conduit mounting plate (12).

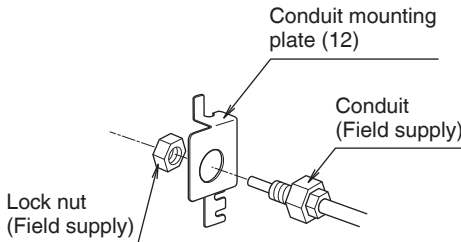

Fig. 24-1

- Attach the wire sealing material (small) (10) to the conduit, the power supply wiring and the ground wiring.

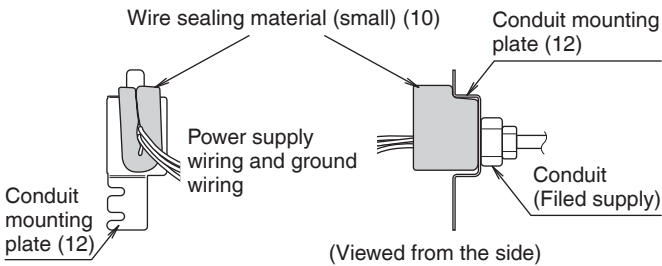

Fig. 24-2

- Loosen the screws (2 locations) in part A.

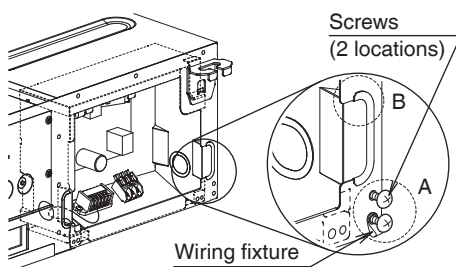

Fig. 24-3

- Insert the hook part of the conduit mounting plate (12) into part B and secure the conduit mounting plate (12) with the screws loosened (2 locations).

NOTE

1. Remove the wiring fixture if you have difficulty in performing this step.

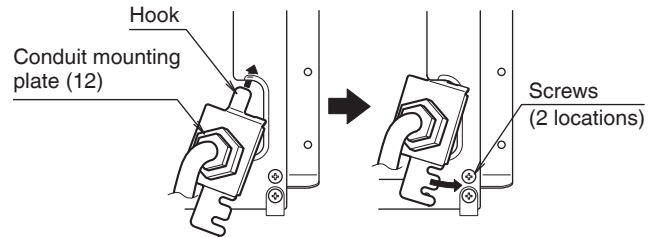

Fig. 24-4

(3) Connect the wiring into the control box through the wiring intake beside the control box.

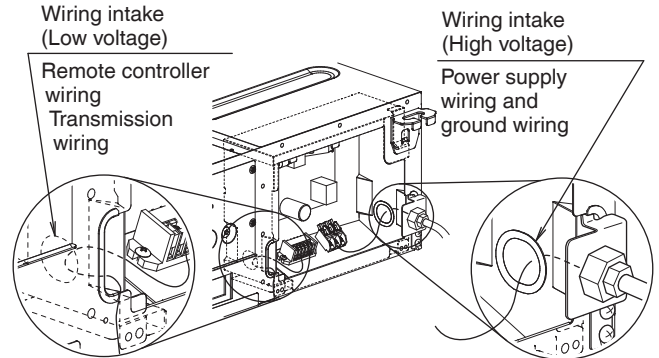
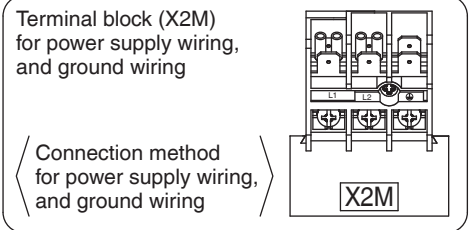

Fig. 25

(4) Follow the instructions below and perform wiring in the control box.



Securely fix the wiring to the provided wiring fixture with the clamp (8).

Remote controller wiring (Low voltage)

Connect the wiring through the control box up to the sheathed part.

Terminal block (X1M) for remote controller wiring, and transmission wiring

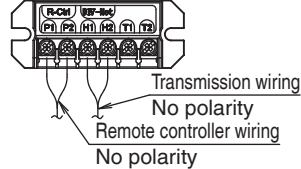

⊘ Prohibited
Never connect the power supply wiring.

Power supply wiring (High voltage)
Ground wiring (High voltage)

<Remote controller wiring method>

Fig. 26

NOTE

1. Secure the wiring between the wiring intake and conduit with the clamp (8) so that the wiring will not become loose.

(5) Mount the control box cover and wrap the wire sealing material (small) (10) so that the wiring through hole will be covered by the sealing material.

- Seal the clearance around the wirings with putty or insulating material (Field supply).
(If insects and small animals get into the indoor unit, short-circuiting may occur inside the control box.)

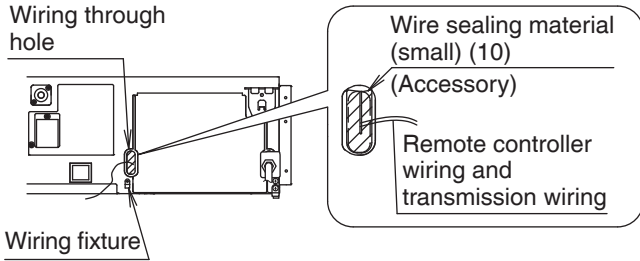

Fig. 27

(6) Securely fix each wire with the provided clamp material (8).

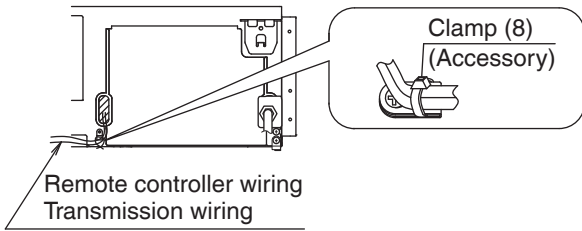
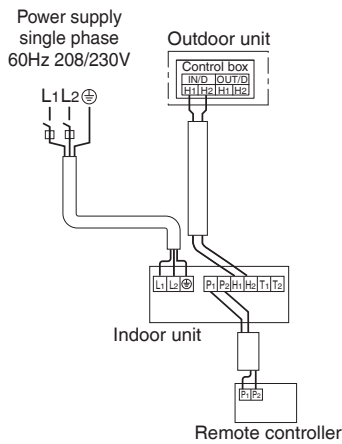

Fig. 28

9-5 WIRING EXAMPLE

< No. 1 system: When using 1 remote controller (Normal operation) >



< No. 2 system: When using 2 remote controllers >

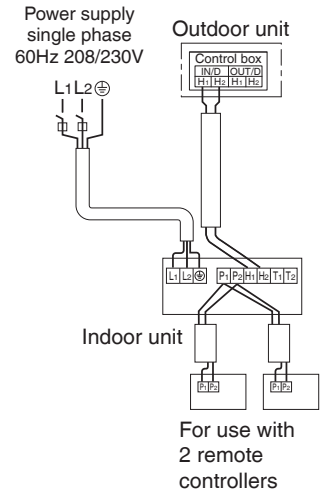

NOTE

- Remote controller wiring and transmission wiring have no polarity.

9-6 FOR CONTROL WITH 2 REMOTE CONTROLLERS (TO CONTROL 1 INDOOR UNIT WITH 2 REMOTE CONTROLLERS)

- For control with 2 remote controllers, set one remote controller as Main and the other remote controller as Sub.

< Changeover method from Main to Sub and vice versa >

Refer to the installation manual attached to the remote controller.

< Wiring method >

- Remove the control box cover.
- Carry out additional wiring from the remote controller 2 (Sub) to the terminals (P1, P2) for remote controller wiring on the terminal block (X1M) in the control box.

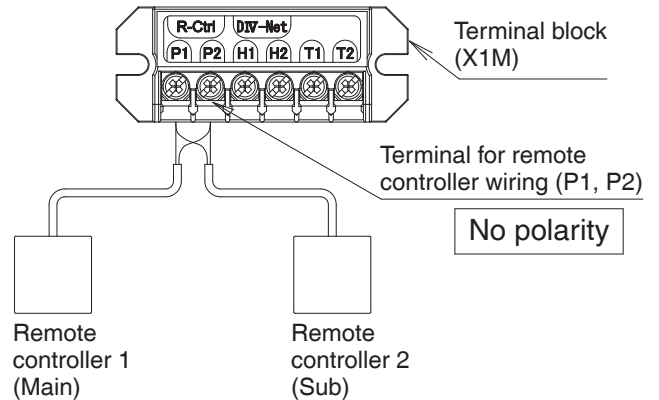

9-7 FOR CENTRALIZED CONTROL

- When centralized equipment (such as centralized controller) is used for control, it is required to set the group No. on the remote controller.
For details, refer to the manuals attached to the centralized equipment.
- Connect the centralized equipment to the indoor unit connected to the remote controller.

9-8 FOR REMOTE CONTROL (FORCED OFF OR ON / OFF OPERATION)

(1) Wiring method and specification

- Remote control is available by connecting the external input to the terminal T1 and T2 on the terminal block for remote controller and transmission wiring (X1M).

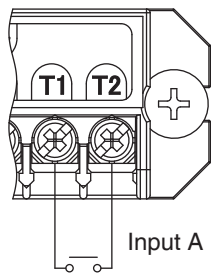

Wiring specification	Sheathed vinyl cord or 2 core cable
Wiring size	AWG 18-16 (0.75-1.25 mm ²)
Wiring length	Max. 328 ft. (100 m)
External contact spec	Contact that can make and break the min. load of DC 15 V · 1 mA

(2) Actuation

- Input A of FORCED OFF and ON/OFF OPERATION will be as the table shown below.

	Input A = ON	Input A = OFF
In case of FORCED OFF	Remote controller prohibited	Remote controller permitted
In case of ON/OFF OPERATION	Operation	Stop

(3) How to choose FORCED OFF or ON/OFF OPERATION

- For choosing FORCED OFF or ON/OFF OPERATION, setting by remote controller is required.
(Refer to 10. FIELD SETTING)

10. FIELD SETTING

⚠ CAUTION

Before carrying out field setting, check the items mentioned in (1) Items to be checked after the installation work is completed on page 3.

- Check if all the installation and piping works for the air conditioner are completed.
- Check that the outside panel and piping cover of the indoor and outdoor units are closed.

< FIELD SETTING >

After turning on the power supply, carry out field setting from the remote controller according to the installation state.

- Carry out setting at 3 places, "Mode No.", "FIRST CODE No." and "SECOND CODE No.". The settings shown by in the following tables indicate those when shipped from the factory.
- The method of setting procedure and operation is shown in the installation manual attached to the remote controller.
- Ask your customer to keep the manual attached to the remote controller together with the operation manual.
- Do not carry out settings other than those shown in the table.
- Settings are performed by selecting "Mode No.", "FIRST CODE No.", and "SECOND CODE No."

10-1 Settings for external static pressure

- Make settings in either method (a) or method (b).

(a) Make settings with Air volume automatic adjustment function.

“Air volume automatic adjustment” function: The air volume is adjusted to the rated air volume automatically.

⚠ CAUTION

- Be sure to check that the external static pressure is within the specification range before making settings. The external static pressure will not be automatically adjusted and air volume insufficiency or water leakage may result if the external static pressure is outside the range. (Refer to the technical document for the setting range of external static pressure.)

(1) Check that the electrical wiring and duct work have been completed.
(If the closing damper is set midway, be sure to check that the damper is opened. Furthermore, check that the air passage on the suction side is provided with an air filter (field supply)).

(2) If air conditioner has more than one discharge and suction, be sure to make adjustments so that the air volume ratio of each discharge and the corresponding suction will conform to the designed air volume ratio.
In that case, set the operating mode to “Fan”. (In the case of changing the air volume, press the fan speed button on the remote controller and change the current selection to “High”, “Medium”, or “Low”.)

(3) Make settings to adjust the air volume automatically.
After setting the operating mode to “Fan”, set the air conditioner to field setting mode with the operation of the air conditioner stopped. Select Mode No. [21], select FIRST CODE No. “7”, and set the SECOND CODE No. to “03”. Return to the “Basic screen” and press the ON/OFF button.

The operation lamp is lit, and the indoor unit will go into fan operation for air volume automatic adjustments (at which time, do not adjust the opening of the discharge or suction). The air volume adjustments will automatically terminate approximately 1 to 15 minutes after the indoor unit comes into operation, and the operation lamp will be OFF and the indoor unit will come to a stop.

Table 7

Mode No.	FIRST CODE No.	Setting content	SECOND CODE No.		
			01	02	03
21	7	Air volume adjustment	OFF	Air volume adjustment completion	Air volume adjustment start

(4) After the air conditioner comes to a stop, be sure to check with Mode No. [21] per indoor unit that the above SECOND CODE No. is “02”. If the operation of the air conditioner does not stop automatically or the SECOND CODE No. is not set to “02”, repeat the setting procedure from (3).

⚠ CAUTION

- If airflow pathway changes, such as duct and discharge changes, are made after air volume adjustments, be sure to make “Air volume automatic adjustment” again.
- If airflow pathway changes, such as duct and discharge changes, are made after **11. TEST OPERATION** or air conditioner relocation, contact your dealer.

(b) Select external static pressure with the remote controller.

Check with Mode No. [21] per indoor unit that the SECOND CODE No. for the above “Air volume adjustment” is set to “01” (OFF). (The SECOND CODE No. is factory set to “01” (OFF).) Change the SECOND CODE No. by referring to the table below according to the external static pressure of the duct to be connected.

Table 8

External static pressure	Mode No.	FIRST CODE No.	SECOND CODE No.
0.20 inWG (50 Pa)	23	6	02
0.24 inWG (60 Pa)			03
0.28 inWG (70 Pa)			04
0.32 inWG (80 Pa)			05
0.36 inWG (90 Pa)			06
0.40 inWG (100 Pa)			07
0.44 inWG (110 Pa)			08
0.48 inWG (120 Pa)			09
0.52 inWG (130 Pa)			10
0.56 inWG (140 Pa)			11
0.60 inWG (150 Pa)			12
0.64 inWG (160 Pa)			13
0.72 inWG (180 Pa)			14
0.80 inWG (200 Pa)			15

10-2 SETTING WHEN AN OPTIONAL ACCESSORY IS ATTACHED

- For setting when attaching an optional accessory, refer to the installation manual attached to the optional accessory.

10-3 SETTING FAN SPEED DURING THERMOSTAT OFF

- Set the fan speed according to the using environment after consultation with your customer.
- When the fan speed is changed, explain the set fan speed to your customer.

Table 9

Setting	Mode No.	FIRST CODE No.	SECOND CODE No.
Fan speed during cooling thermostat OFF	22	6	01
			02
Fan speed during heating thermostat OFF	22	3	01
			02

10-4 SETTING FILTER SIGN

- A message to inform the air filter cleaning time will be indicated on the remote controller.
- Set the SECOND CODE No. shown in the Table 10 according to the amount of dust or pollution in the room.
- The periodical filter cleaning time can be shortened depending on the environment.

Table 10

Dust level	Hours until indication	Mode No.	FIRST CODE No.	SECOND CODE No.
Normal	Approx. 2500 hrs	20	0	01
More contaminated	Approx. 1250 hrs			02
With indication			3	01
No indication*				02

* Use "No indication" setting when cleaning indication is not necessary such as the case of periodical cleaning being carried out.

10-5 SETTING THERMOSTAT DIFFERENTIAL

- For setting when remote sensor is used, change over thermostat differential.

Table 11

Differential	Mode No.	FIRST CODE No.	SECOND CODE No.
1.8°F (1°C)	22	2	01
0.9°F (0.5°C)			02

10-6 SETTING DRY MODE SET TEMPERATURE

- For changing dry mode set temperature.

Table 12

Setting	Mode No.	FIRST CODE No.	SECOND CODE No.
Room temperature	21	12	01
Same as cooling mode set temperature			02

11. TEST OPERATION

- After cleaning the indoor unit inside, carry out test operation according to installation manual attached to the outdoor unit.
- If the test operation is completed with no malfunction code shown on the remote controller, the system is confirmed to be ready for activating safety measures when refrigerant is detected by the built-in refrigerant sensor.

• When the remote controller operation lamp flashes, it shows that something is abnormal.

Check the malfunction codes on the remote controller.

The relation between the malfunction codes and malfunction details is described in the operation manual attached to the outdoor unit. Particularly, if the indication is one of those shown in the Table 13, it may be an error in the electrical wiring or the power supply is disconnected. Therefore, recheck wiring.

Table 13

Remote controller indication	Details
Though the centralized control is not carried out, the indicating the central control turns on.	<ul style="list-style-type: none"> • The terminals (T1 · T2) for FORCED OFF on the indoor unit transmission terminal block is short circuited.
"U4" turns on "UH" turns on	<ul style="list-style-type: none"> • The power supply to the outdoor unit is not connected. • The power supply wiring to the outdoor unit is not carried out. • The transmission wiring and the remote controller wiring and FORCED OFF wiring are connected wrongly. • The transmission wiring is disconnected.
No indication	<ul style="list-style-type: none"> • The power supply to the indoor unit is not connected. • The power supply wiring to the indoor unit is not carried out. • The remote controller wiring and the transmission wiring and FORCED OFF wiring are connected wrongly. • The remote controller wiring is disconnected.

⚠ CAUTION

After test operation is completed, check the items mentioned in **2. BEFORE INSTALLATION (2) Items to be checked at delivery** on page 4.

If the interior finish work is not completed when the test operation is finished, for protection of the air conditioner, ask the customer not operate the air conditioner until the interior finish work is completed.

If the air conditioner is operated, the inside of the indoor units may be polluted by substances generated from the coating and adhesives used for the interior finish work and cause water splash and leakage.

⚠ To the operator carrying out test operation

After test operation is completed, before delivering the air conditioner to the customer, confirm that the control box cover, the air filter and suction grille are attached. In addition, explain the power supply status (power supply ON/OFF) to the customer.

DAIKIN COMFORT TECHNOLOGIES MANUFACTURING, L.P.

Daikin Texas Technology Park,
19001 Kermier Road,
Waller, TX, 77484, U.S.A.

