

INSTALLATION MANUAL

SPLIT SYSTEM

Air Conditioners

MODEL

Ceiling Mounted Cassette type (Round Flow with Sensing Panel)

FCA18AAVJU

FCA24AAVJU

FCA30AAVJU

FCA36AAVJU

FCA42AAVJU

FCA48AAVJU

English

Français

Español

Please visit <http://www.daikinac.com/content/resources/manuals> for the most current version of installation instructions and service manual. In the event of conflicting information, the online contents are to be used.

Veillez visiter <http://www.daikinac.com/content/resources/manuals> pour obtenir la version la plus récente des instructions d'installation et du manuel de service. En cas de conflit d'informations, le contenu en ligne est à privilégier.



Visite <http://www.daikinac.com/content/resources/manuals> para obtener la versión más actualizada de las instrucciones de instalación y el manual de servicio en español. En caso de información contradictoria, debe utilizarse el contenido en línea.

CONTENTS

SAFETY CONSIDERATIONS.....[i] [ii]	
1. BEFORE INSTALLATION	1
2. SELECTION OF INSTALLATION LOCATION	2
3. PREPARATION BEFORE INSTALLATION	4
4. INSTALLATION OF INDOOR UNIT	4
5. REFRIGERANT PIPING WORK.....	6
6. DRAIN PIPING WORK	8
7. ELECTRIC WIRING WORK.....	10
8. MOUNTING DECORATION PANEL	14
9. FIELD SETTING.....	14
10. TEST OPERATION.....	15

SAFETY CONSIDERATIONS

Refer also to the General safety considerations attached to the outdoor unit.





	Read the safety considerations in this manual carefully before operating the unit.
	This appliance is filled with R32.

Read these **SAFETY CONSIDERATIONS for Installation** carefully before installing air conditioning equipment. After completing the installation, make sure that the unit operates properly during the startup operation.

Instruct the customer on how to operate and maintain the unit. Inform customers that they should store this Installation Manual with the Operation Manual and General Safety Considerations for future reference.

Always use a licensed installer or contractor to install this unit. Improper installation can result in water or refrigerant leakage, electric shock, fire or explosion.

Meanings of **DANGER, WARNING, CAUTION, and NOTE** Symbols:

-  **DANGER**Indicates an imminently hazardous situation which, if not avoided, will result in death or serious injury.
-  **WARNING**Indicates a potentially hazardous situation which, if not avoided, could result in death or serious injury.
-  **CAUTION**Indicates a potentially hazardous situation which, if not avoided, may result in minor or moderate injury. It may also be used to alert against unsafe practices.
-  **NOTE**Indicates situations that may result in equipment or property damage accidents only.

DANGER

- Refrigerant gas is heavier than air and replaces oxygen. A massive leak can lead to oxygen depletion, especially in basements, and an asphyxiation hazard could occur leading to serious injury or death.
- Do not ground units to water pipes, gas pipes, telephone wires, or lightning rods as incomplete grounding can cause a severe shock hazard resulting in severe injury or death. Additionally, grounding to gas pipes could cause a gas leak and potential explosion causing severe injury or death.
- If refrigerant gas leaks during installation, ventilate the area immediately. Refrigerant gas may produce toxic gas if it comes in contact with fire. Exposure to this gas could cause severe injury or death.
- After completing the installation work, check that the refrigerant gas does not leak throughout the system.
- Do not install unit in an area where flammable materials are present due to risk of explosions that can cause serious injury or death.
- Safely dispose of all packing and transportation materials in accordance with federal/state/local laws or ordinances. Packing materials such as nails and other metal or wood parts, including plastic packing materials used for transportation may cause injury or death by suffocation.

WARNING

- Only qualified personnel must carry out the installation work. Installation must be done in accordance with this installation manual. Improper installation may result in water leakage, electric shock or fire.
- When installing the unit in a small room, take measures to keep the refrigerant concentration from exceeding allowable safety limits. Excessive refrigerant leaks, in the event of an accident in a closed ambient space, can lead to oxygen deficiency.
- Use only specified accessories and parts for installation work. Failure to use specified parts may result in water leakage, electric shock, fire or the unit falling.
- Install the air conditioner or heat pump on a foundation strong enough that it can withstand the weight of the unit. A foundation of insufficient strength may result in the unit falling and causing injury.
- Take into account strong winds, typhoons, or earthquakes when installing. Improper installation may result in the unit falling and causing accidents.
- Make sure that a separate power supply circuit is provided for this unit and that all electrical work is carried out by qualified personnel according to local, state and national regulations. An insufficient power supply capacity or improper electrical construction may lead to electric shock or fire.
- Make sure that all wiring is secured, that specified wires are used, and that no external forces act on the terminal connections or wires. Improper connections or installation may result in fire.
- When wiring, position the wires so that the control box cover can be securely fastened. Improper positioning of the control box cover may result in electric shock, fire or the terminals overheating.
- Before touching electrical parts, turn off the unit.
- Do not use means to accelerate the defrosting process or to clean, other than those recommended by the manufacturer.
- The appliance shall be stored in a room without continuously operating ignition sources (for example: open flames, an operating gas appliance or an operating electric heater).
- Do not pierce or burn.
- Be aware that refrigerants may not contain an odor.

- Comply with national gas regulations.
- This equipment can be installed with a Ground-Fault Circuit Interrupter (GFCI). Although this is a recognized measure for additional protection, with the grounding system in North America, a dedicated GFCI is not necessary.
- When installing or relocating the system, keep the refrigerant circuit free from substances other than the specified refrigerant (R32) such as air. Any presence of air or other foreign substance in the refrigerant circuit can cause an abnormal pressure rise or rupture, resulting in injury.
- Do not change the setting of the protection devices. If the pressure switch, thermal switch, or other protection device is shorted and operated forcibly, or parts other than those specified by Daikin are used, fire or explosion may occur.
- Do not install in a wet room such as a bathroom or laundry room due to a risk of fire or electric shock.
- That pipe-work including piping material, pipe routing, and installation shall include protection from physical damage in operation and service, and be in compliance with national and local codes and standards, such as ASHRAE 15, ASHRAE 15.2, IAPMO Uniform Mechanical Code, ICC International Mechanical Code, or CSA B52. All field joints shall be accessible for inspection prior to being covered or enclosed;

CAUTION

- Do not touch the switch with wet fingers. Touching a switch with wet fingers can cause electric shock.
- Do not allow children to play on or around the unit to prevent injury.
- Do not touch the refrigerant pipes during and immediately after operation as the refrigerant pipes may be hot or cold, depending on the condition of the refrigerant flowing through the refrigerant piping, compressor, and other refrigerant cycle parts. Your hands may suffer burns or frostbite if you touch the refrigerant pipes. To avoid injury, give the pipes time to return to normal temperature or, if you must touch them, be sure to wear proper gloves.
- The heat exchanger fins are sharp enough to cut. To avoid injury wear gloves or cover the fins when working around them.
- Install drain piping to proper drainage. Improper drain piping may result in water leakage and property damage.
- Insulate piping to prevent condensation.
- Be careful when transporting the unit.
- Do not turn off the power supply immediately after stopping operation. Always wait for at least 5 minutes before turning off the power supply. Otherwise, water leakage may occur.
- Do not use a charging cylinder. Using a charging cylinder may cause the refrigerant to deteriorate.
- Refrigerant R32 in the system must be kept clean, dry, and tight.
 - (a) Clean and Dry - Foreign materials (including mineral oils such as SUNISO oil or moisture) should be prevented from getting into the system.
 - (b) Tight - R32 does not contain any chlorine, does not destroy the ozone layer, and does not reduce the earth's protection against harmful ultraviolet radiation. R32 can contribute to the greenhouse effect if it is released. Therefore take proper measures to check for the tightness of the refrigerant piping installation. Read the chapter Refrigerant Piping Work and follow the procedures.
- The indoor unit is for R32. See the catalog for indoor models that can be connected. Normal operation is not possible when connected to other units.
- Indoor units are for indoor installation only. Outdoor units can be installed either outdoors or indoors.

- Do not install the air conditioner or heat pump in the following locations:
 - (a) Where a mineral oil mist or oil spray or vapor is produced, for example, in a kitchen. Plastic parts may deteriorate and fall off or result in water leakage.
 - (b) Where corrosive gas, such as sulfurous acid gas, is produced. Corroding copper pipes or soldered parts may result in refrigerant leakage.
 - (c) Near machinery emitting electromagnetic waves. Electromagnetic waves may disturb the operation of the control system and cause the unit to malfunction.
 - (d) Where flammable gas may leak, where there is carbon fiber, or ignitable dust suspension in the air, or where volatile flammables such as thinner or gasoline are handled. Operating the unit in such conditions can cause fire.

NOTE

- Install the power supply and transmission wires for the indoor and outdoor units at least 3.5 ft. (1 m) away from televisions or radios to prevent image interference or noise. Depending on the radio waves, a distance of 3.5 ft. (1 m) may not be sufficient to eliminate the noise.
 - Dismantling the unit, treatment of the refrigerant, oil and additional parts must be done in accordance with the relevant local, state, and national regulations.
 - Only use tools for R32, such as a gauge manifold, charge hose, gas leak detector, reverse flow check valve, refrigerant charge base, vacuum gauge, or refrigerant recovery equipment.
 - If the conventional refrigerant and refrigerator oil are mixed in R32, the refrigerant may deteriorate.
 - This air conditioner or heat pump is an appliance that should not be accessible to the general public.
 - As design pressure is 580 psi (4.0 MPa), the wall thickness of field-installed pipes should be selected in accordance with the relevant local, state, and national regulations.
 - A refrigerant sensor is mounted in the indoor units. Do not use gas appliances using flammable gas (propane, butane, methane, etc.), sprays using flammable gas (LPG, etc.) such as insecticide or hair spray, smoke, medical agent and paint in the vicinity. If it reacts, a malfunction code is displayed and the operation may not be able to be performed.
 - Once the refrigerant sensor reacts, it needs to be replaced with a new one.
-





1. BEFORE INSTALLATION





When unpacking the indoor unit or moving the unit after unpacked, hold the hanger brackets (4 places) and do not apply force to other parts (particularly refrigerant piping, drain piping and resin parts).



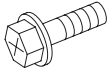

- Make sure to check in advance that the refrigerant to be used for installation work is R32.
The air conditioner will not operate properly without the correct refrigerant.
- For installation of the outdoor unit and additional refrigerant charge, refer to the installation manual attached to the outdoor unit.
- Do not throw away the accessories until the installation work is completed.
 - (1) Measure the unit with packaging to ensure the unit can be carried safely while still packaged.
 - (2) Determine the route to carry the unit into the room.
 - (3) Do not unpack the unit until it is carried to the installation location.
Where unpacking is unavoidable, use a sling of soft material or protective plates together with a rope when lifting, to avoid damage or scratches to the indoor unit.
- After the indoor unit is carried into the room, to avoid the indoor unit from getting damaged, take measures to protect the indoor unit with packing materials until the installation begins.
- Have the customer actually operate the air conditioner while looking at the operation manual.
Instruct the customer how to operate the air conditioner (particularly cleaning of the air filter, operation procedures, and temperature adjustment).
- For selection of installation location, use the installation pattern combined packing material paper as reference.
- Do not use the air conditioner where in the salty atmosphere such as coastal areas, vehicles, vessels or the voltage fluctuation is frequent such as factories.
- Take off static electricity from the body when carrying out wiring and the control box cover is removed.
The electric parts may be damaged.

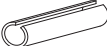

1-1 ACCESSORIES

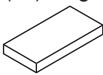
Check if the following accessories are attached to the indoor unit.

Name	(1) Drain hose	(2) Metal clamp	(3) Washer for hanger bracket	(4) Clamp
Quantity	1 pc.	1 pc.	8 pcs.	7 pcs.
Shape				

Name	(5) Installation pattern paper	(6) Screw (M4)	(7) Washer fixing plate	Joint insulating material
Quantity	1 sheet	4 pcs.	4 pcs.	1 each
Shape	 Top packaging			 (8) For gas piping  (9) For liquid piping

Name	Sealing material		
Quantity	1 each	1 sheet	1 pc.
Shape	(10) Large  (11) Medium-1 	(12) Medium-2 	(13) Small  (14) 

Name	(15) Installation guide	(16) Insulation tube	Conduit mounting plate	(Miscellaneous)
Quantity	1 sheet	1 pc.	1 pc.	• Operation Manual • Operation Manual (Regarding copyright) • Installation Manual • Warranty
Shape			(17) 	

- Joint insulating material (8) and (9) are for field piping that is insulated to a thickness of 3/8 in. (10 mm) or less. If the field piping is insulated to a thickness of more than 3/8 in. (10 mm), instead of using joint insulating material (8) and (9), use insulating material and clamps (both field supply) that are suitable for the field piping, and be sure to carry out insulation according to the procedure in this manual.
If not insulated, water leakage may be caused by condensation.
- Screws for fixing the panel are attached to the decoration panel.

1-2 OPTIONAL ACCESSORIES

- This indoor unit separately requires a decoration panel and remote controllers.
- Confirm if a decoration panel shown in the Table 1 is prepared and meets your model.
(Refer to the installation manual attached to the decoration panel for how to install.)

Table 1

MODEL NAME (FCA-AAVJU)	Optional decoration panel
18 · 24 · 30 · 36 · 42 · 48	BYCQ54GEFU, BYCQ54GEGFU Color : Fresh white

- Install the remote controller to the place where the customer has given consent.
Refer to the catalog for the applicable model.
(Refer to the installation manual attached to the remote controller for how to install.)

CARRY OUT THE WORK GIVING CAUTION TO THE FOLLOWING ITEMS AND AFTER THE WORK IS COMPLETED, CHECK THEM AGAIN.

(1) Items to be checked after the installation work is completed

Items to be checked	In case of defective	✓
Are the indoor and outdoor units rigidly fixed?	Drop · vibration · noise	
Is the installation work of the outdoor and indoor units completed?	Does not operate · burnout	
Have you carried out air tight test with the test pressure specified in the outdoor unit installation manual?	Does not cool / Does not heat	

Items to be checked	In case of defective	✓
Is the insulation of refrigerant piping and drain piping completely carried out?	Water leakage	
Does the drain flow out smoothly?	Water leakage	
Is the power supply voltage identical to that stated in the name plate on the air conditioner?	Does not operate · burnout	
Are you sure that there is no wrong wiring or piping or no loose wiring?	Does not operate · burnout	
Is grounding completed?	Danger in case of leakage	
Are the sizes of electric wiring according to the specification?	Does not operate · burnout	
Is any of air outlets or inlets of the indoor and outdoor units blocked with obstacles? If so, it could cause the capacity to drop due to fan-speed drop or malfunction of equipment.	Does not cool / Does not heat	
Have you recorded the refrigerant piping length and the refrigerant charge added?	Refrigerant charge amount is not clear	

Make sure to recheck the items of **SAFETY CONSIDERATIONS**.

(2) Items to be checked at time of delivery

Items to be checked	✓
Have you carried out field setting? (if necessary)	
Are the control box cover, the air filter and the suction grille attached?	
Is the cool air discharged during the cooling operation and the warm air discharged during the heating operation? Have you checked to make sure the indoor unit does not make unpleasant air-discharged sounds?	
Have you explained how to operate the air conditioner while showing the operation manual to the customer?	
Have you explained the description of cooling, heating, program dry and automatic (cooling/heating) while showing the operation manual to the customer?	
If you set the fan speed at thermostat OFF, did you explain the set fan speed to the customer?	
Have you handed the operation manual and the installation manual to the customer?	
Have you checked that there is no generation of abnormal noise (i.e., noise resulting from contamination or missing parts)?	
If an optional accessory is in use, did you check the operation of the optional accessory and make field settings as needed?	
Is the remote controller icon displayed? Is the remote controller connected to the master unit if the system is in simultaneous multi operation?	
Have you explained failure examples of 2. SELECTION OF INSTALLATION LOCATION?	

Points of the operation explanation

In addition to the general usage, since the items in the operation manual with the **⚠ WARNING** and **⚠ CAUTION** marks are likely to result in human bodily injuries and property damages, it is necessary not only to explain these items to the customer but also to have the customer read them. Furthermore, it is necessary to have the customer read through the troubleshooting items while explaining the above items.

2. SELECTION OF INSTALLATION LOCATION

R32 refrigerant is a mildly flammable refrigerant. Do not install indoor or outdoor units in areas where, in the event of a refrigerant leakage, refrigerant concentrations could exceed flammable concentrations.

Hold the hanger brackets at 4 locations to move the indoor unit when unpacking or after unpacked, and do not apply force to the piping (refrigerant and drain) and resin parts. If the temperature and humidity in the ceiling is likely to exceed 86°F (30°C), RH80%, additionally stick insulation to the indoor unit.

Use the insulation such as glass wool or polyethylene that has thickness of 3/8 in. (10 mm) or more. However, keep the insulated outside dimension smaller than the ceiling opening so that the unit may go through the opening at installation.

The direction of air discharge can be selected. Sealing material of air discharge outlet is available option for 4-way with sealed corners and 3-way.

(1) Select the installation location that meets the following conditions and get approval from the customer.

- Where the cool and warm air spreads evenly in the room.
- Where there are no obstacles in the air passage.
- Where drainage can be ensured.
- Where the ceiling surface is not inclined.
- Where there is sufficient strength to withstand the weight of the indoor unit. If the strength is insufficient, the indoor unit may vibrate and get in contact with the ceiling and generate noise.
- Where a space sufficient for installation and service can be ensured. **(Refer to Fig. 1)**
- Where the piping length between the indoor and the outdoor units is ensured within the allowable length. Refer to the installation manual attached to the outdoor unit.
- Where there is no risk of flammable gas leak.

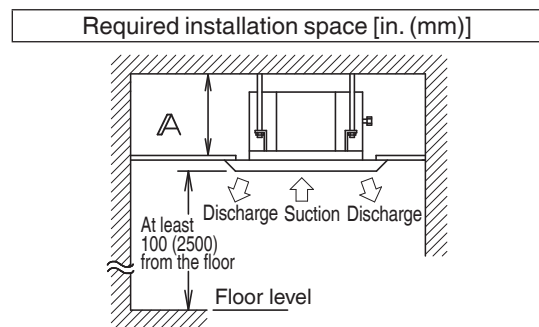

Fig. 1

MODEL NAME (FCA-AAVJU)	A [in. (mm)]	
	BYCQ54GEFU	BYCQ54GEGFU
18 · 24	10 (261)	13-1/4 (341)
30 · 36 · 42 · 48	11-3/4 (303)	14-7/8 (383)

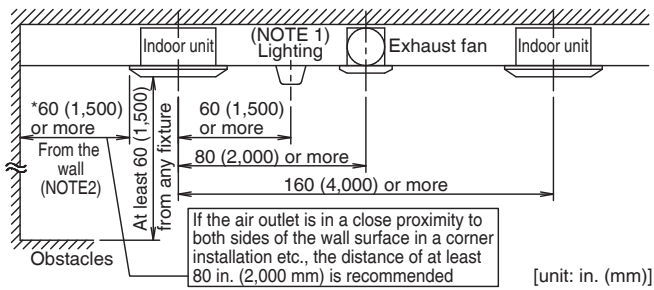

Fig. 2

NOTE

1. If the air passage is obstructed, or if the installation space requirements are not met, performance may decrease or the thermostat may easily turn off due to reduced airflow rate and intake of discharged air.
2. In a roadside store or restaurant, the air flows in the order of outdoor → attic → living space because the ventilation system creates negative pressure in living space. As a result, condensation may arise since the temperature and humidity around the indoor unit become similar to the outdoor environment due to direct intake of outside air into the attic.

CAUTION

- Any vents, light fixtures, or other appliances which may disturb the airflow might soil the ceiling if too close, so follow Fig. 2 when installing.

Note)

1. This restriction applies to the exposed type lighting, but does not apply to the recessed type, which does not protrude below the ceiling line.
2. The clearance from the wall (indicated with *) must be 20 in. (500 mm) or more if the air outlet is closed or the horizontal blade is set to Airflow block and, if the corners (left and right corners of the target air outlet) are also closed by 8 in. (200 mm) or more.

For how to set the airflow direction (including Airflow block) with the horizontal blade, refer to **Individual Airflow Direction** in the operation manual attached to the remote controller.

- Install the indoor and outdoor units, power supply wiring, remote controller wiring and transmission wiring at least 40 in. (1 m) away from televisions or radios to prevent image interference or noise. (Depending on the radio waves, a distance of 40 in. (1 m) may not be sufficient to eliminate the noise.)
- Install the indoor unit as far as possible from fluorescent lamps.
- Localized temperature difference from the room temperature, if too large, can affect how the infrared floor sensor judges. (This may occur, for example, in an area where floor heating/high-temperature heat generating equipment is installed.)
- Each sensor has been set so that the center of the sensing area is located in the center of the product 32 in. (800 mm) above the floor (in case of the infrared presence sensor) or 0 in. (0 mm) above the floor (in case of the infrared floor sensor) when the ceiling height is approximately 8-3/4 ft. (2.7 m).

(2) Ceiling height

- This indoor unit can be installed in a space of which ceiling height is up to 11-1/2 ft. (3.5 m) (Type 30 · 36 · 42 · 48: 13-3/4 ft. (4.2 m))
- However, if the ceiling height exceeds 8-3/4 ft. (2.7 m) (Type 30~48: 10-1/2 ft. (3.2 m)), it is necessary to set from the remote controller on site. Refer to the section **9. FIELD SETTING** and **10. TEST OPERATION**.

(3) Direction of the air discharge

- Select the number of directions of the optimum air discharge for the shape or the position of the room.
- The number of directions of the air discharge can be changed by installing a sealing material.
- When installing a sealing material, the field setting from the remote controller is required. For details, refer to the installation manual attached to the sealing materials. (It is set to the setting position number **01** (Standard · All round outlet) when shipped from the factory.)
- To use the optional sealing material kit to change the setting of air discharge direction (4-way blow type (with corners sealed)/3-way blow type/2-way blow type), refer to the installation manual attached to it.

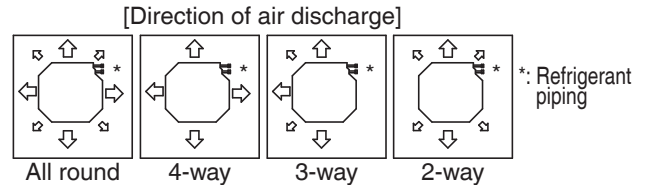

Fig. 3

NOTE

Depending on the temperature, humidity and airflow conditions in the attic due to the indoor airflow (air draft from exhaust fan, etc.), outside air intake and so on, condensation may arise on the ceiling near the corner air outlet. In that case, close the corner air outlet using the sealing material kit (sold separately).

(4) Use suspension bolts for installation.

Investigate if the installation place can withstand the weight of the indoor unit and, if necessary, hang the indoor unit with bolts after it is reinforced by beams etc. (Refer to the installation pattern paper (5) for the mounting pitch.)

(5) Infrared presence/floor sensor's sensing area

The sensing area is shown in the figure below.

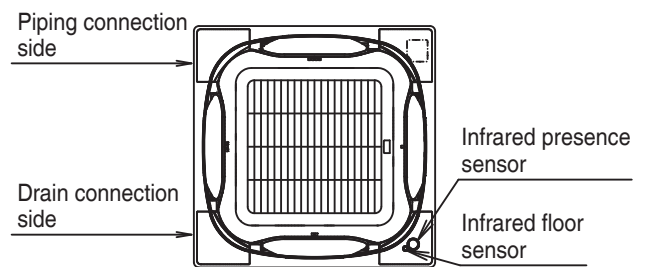
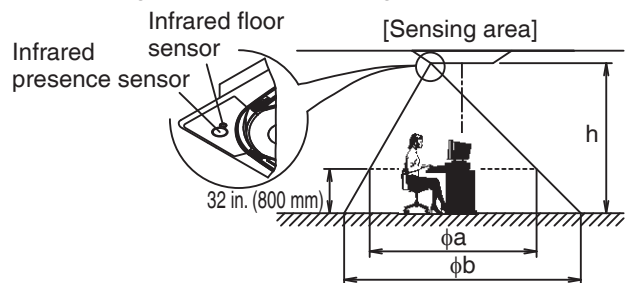

Indoor unit installation height h [ft. (m)]	8-3/4 (2.7)	11-1/2 (3.5)	13 (4.0)
Infrared presence sensor φa [ft. (m)]	Approx. 28 (8.5)	Approx. 37-1/2 (11.5)	Approx. 44-1/2 (13.5)
Infrared floor sensor φb [ft. (m)]	Approx. 36 (11)	Approx. 46 (14)	Approx. 52-1/2 (16)

3. PREPARATION BEFORE INSTALLATION

(1) Check the relation of location between the ceiling opening and the indoor unit suspension bolts.

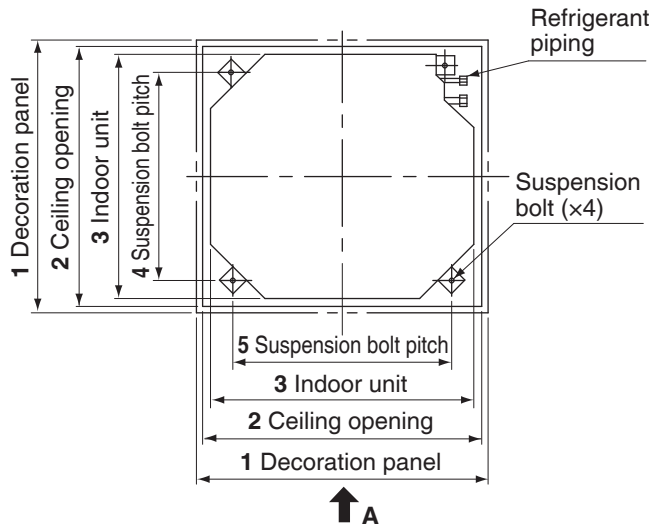
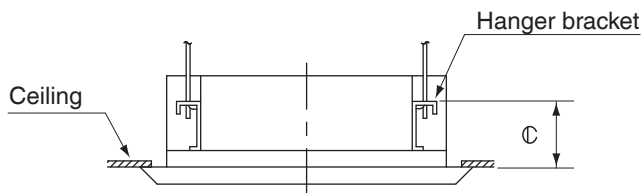

Fig. 4

[unit: in. (mm)]

1	37-3/8 (950)
2	33-7/8 – 35-7/8 (860 – 910)
3	33-1/16 (840)
4	30-3/4 (780)
5	28 (710)



A arrow view
Fig. 5

Decoration Panel	BYCQ54GEFU	BYCQ54GEGFU
C in. (mm)	4-15/16 – 5-1/8 (125 – 130)	8-1/16 – 8-1/4 (205 – 210)

NOTE

If the indoor unit is not positioned at the correct height, there will be a gap between it and the decoration panel that could result in water leakage or abnormal noise.

CAUTION

Reduce the distance between the unit and ceiling to 1-3/8 in. (35 mm) or below in order to maintain an overlapping panel margin 13/16 in. (20 mm) for the opening on the ceiling. If the distance exceeds 1-3/8 in. (35 mm), attach ceiling material to the part marked or replace the ceiling. (Refer to Fig. 6)

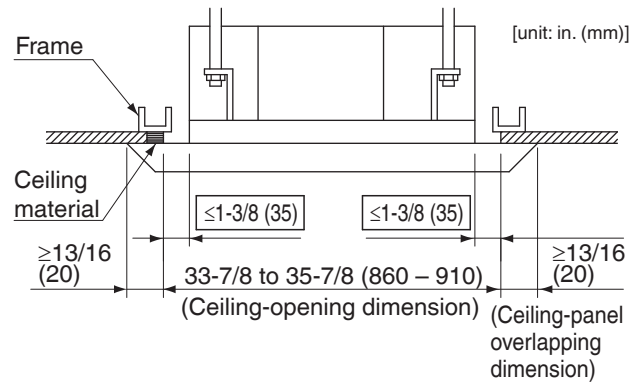

Fig. 6

(2) Make the ceiling opening required for installation.

- Use the installation pattern paper (5) matched to the ceiling opening dimension.
- Make the ceiling opening required for installation at the installation location and carry out refrigerant/drain piping, power supply wiring, remote controller wiring and transmission wiring. (Refer to each section 5. REFRIGERANT PIPING WORK, 6. DRAIN PIPING WORK and 7. ELECTRIC WIRING WORK)
- After making the opening, it may be necessary to reinforce the ceiling framework to maintain a level ceiling and prevent it from vibrating. For details, consult with the builder and interior designer.

(3) Install the suspension bolts.

(Use a M8-M10 sized bolt or equivalent.)

- Use hole-in-anchors for the existing bolts and embedded inserts or foundation bolts for new bolts, and fix the indoor unit firmly to the building so that it may withstand the weight of the unit. In addition, adjust clearance (2 – 4 in. (50 – 100 mm)) from the ceiling in advance.

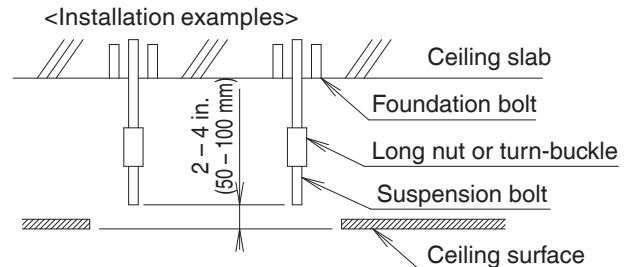

Note) The above shown parts are all field supply.

4. INSTALLATION OF INDOOR UNIT

<<It is easy to attach the optional accessories (except for decoration panel) before installing the indoor unit. Refer to also the installation manual attached to the optional accessories.>>

For installation, use the attached accessories and specified accessories.

[Install the indoor unit in the order of steps (1), (2), (3), (4), (5) and (6) in case of a newly built ceiling, or in the order of steps (1), (3), (4) and (5) in case of an existing ceiling.]

- (1) Install the indoor unit temporarily.
- Fix the hanger bracket to the suspension bolt. Make sure to securely fix the hanger bracket with the nut and the washer for hanger bracket (3) from the upper and lower side. **(Refer to Fig. 7)**

If the washer fixing plate (7) is used, the upper side washer for hanger bracket (3) may be protected from falling off.

(Refer to Fig. 8)

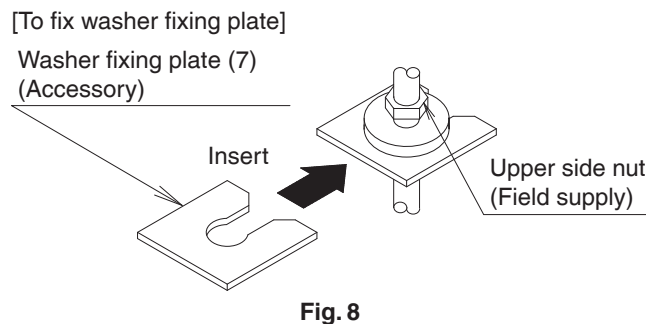
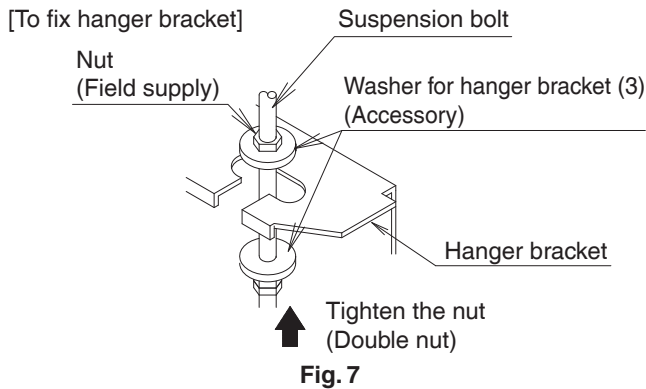

- (2)
- The installation pattern paper (5) is matched to the ceiling opening dimension. For the height of ceiling lower surface from the floor level, confirm with the builder of ceiling.
 - The center of the ceiling opening is shown in the installation pattern paper (5). The center of the indoor unit is indicated as triangle marks on the sides and bottom of the unit and those on the installation pattern paper (5).
 - Put the installation pattern paper (5) to the indoor unit with four screws (6). At this time, put the installation pattern paper (5) to the indoor unit with the triangle marks on the indoor unit and those on the installation pattern paper (5) aligned.

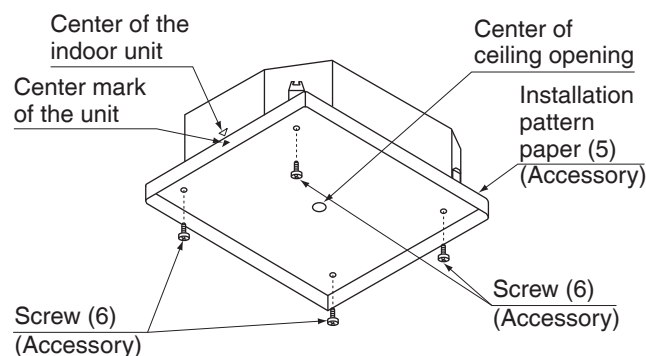

< Installation work after the ceiling work is finished >

- (3) Adjust the indoor unit to be located at the correct position. (Refer to 3. PREPARATION BEFORE INSTALLATION – (1))
- Using the Installation guide (15) allows you to check the position from the underside of the unit to the lower ceiling surface.

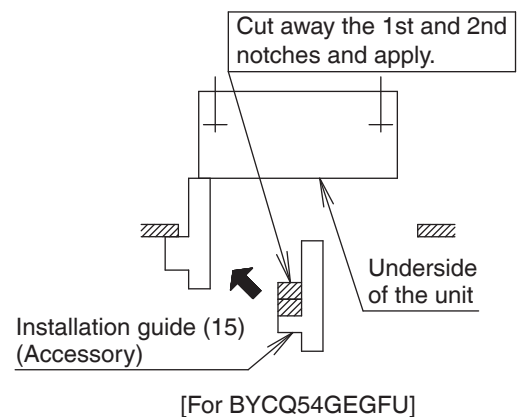
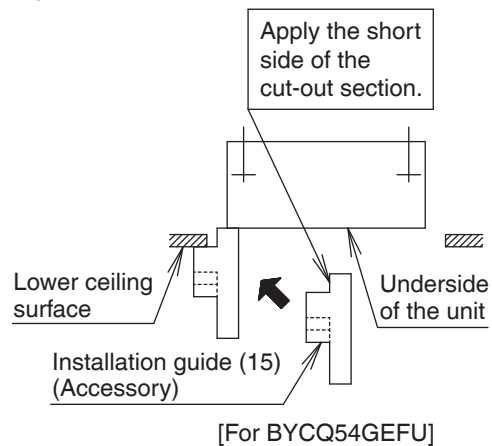

- (4) Check the level of the unit. **(Refer to Fig. 9)**
- (5) Remove the washer fixing plate (7) used for preventing the washer for hanger bracket (3) from dropping and tighten the upper side nut.
- (6) Remove the installation pattern paper (5).

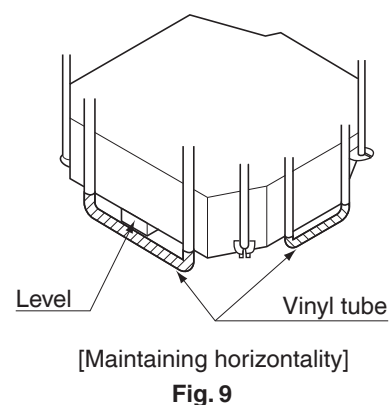

CAUTION

- **Install the indoor unit horizontally.**
If the indoor unit is inclined and the drain piping side gets high, it may cause malfunction of a float switch and results in water leakage.
- **Attach nuts on the upper and lower side of hanger bracket.**
If there is no upper nut and the lower nut is over-tightened, the hanger bracket and the top plate malfunction and create unwanted noise.
- **Do not insert materials other than those specified into the clearance between the hanger bracket and the washer for hanger bracket (3).**
Unless the washers are properly attached, the suspension bolts may come off from the hanger bracket.

WARNING

The indoor unit must be securely installed on a place that can withstand the weight.
If the strength is insufficient, the indoor unit may fall down and cause injuries.

5. REFRIGERANT PIPING WORK

- For the outdoor unit refrigerant piping, refer to the installation manual attached to the outdoor unit.
- Carry out insulation of both gas and liquid refrigerant piping securely. If not insulated, it may cause water leakage. For gas piping, use insulation material of which heat resistant temperature is not less than 250°F (120°C). For use under high humidity, strengthen the insulation material for refrigerant piping. If not strengthened, the surface of insulation material may sweat.
- Before installation work, make sure that the refrigerant is R32 or operation will malfunction. (Unless the refrigerant is R32, the normal operation cannot be expected.)

CAUTION

This air conditioner is a dedicated model for refrigerant R32. Make sure to meet the requirements shown below and carry out installation work.

- **Use dedicated piping cutters and flaring tools for R32.**
- **When making a flare connection, coat only the flared inner surface with ether oil or ester oil.**
- **Use only the flare nuts attached to the indoor unit.**
If other flare nuts are used, it may cause refrigerant leakage.
- **To prevent contamination or moisture from getting into the piping, take measures such as pinching or taping the piping.**

Do not mix substance other than the specified refrigerant such as air into the refrigeration circuit.

If the refrigerant leaks during the work, ventilate the room.

Maintain good ventilation while carrying out work and ensure that there are no open flames in the vicinity.

- The refrigerant is pre-charged in the outdoor unit.
- When connecting the piping to the air conditioner, make sure to use a spanner and a torque wrench as shown in Fig. 10.
- Using a tool other than a spanner may destroy the flare nut thread, resulting in refrigerant leakage due to poor tightening.

- For the dimension of flared part and the tightening torque, refer to the Table 2.
- Use the flare nuts attached to the piping of indoor unit.
- When making a flare connection, coat only the flared inner surface with ether oil or ester oil.

(Refer to Fig. 11)

Then, turn the flare nut 3 to 4 times with your hand and screw in the nut.

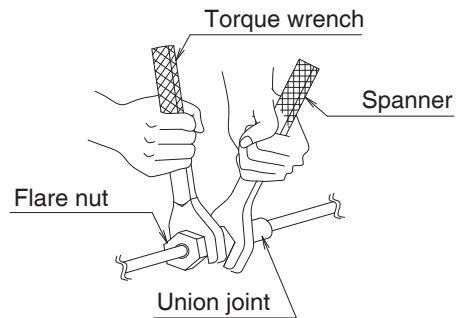

Fig. 10

Coat only the flared inner surface with ether oil or ester oil

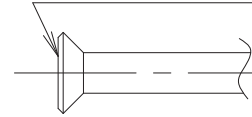

Fig. 11

Table 2

Piping size [in. (mm)]	Tightening torque [lbf.ft. (N·m)]	Dimension for processing flare A [in. (mm)]	Flare shape [in. (mm)]
φ 3/8 (9.5)	24.1 – 29.4 (36.3±3.6)	0.504 – 0.520 (13.0±0.2)	
φ 5/8 (15.9)	45.6 – 55.6 (68.6±6.8)	0.760 – 0.776 (19.5±0.2)	

CAUTION

Do not let oil adhere to the screw fixing part of resin parts.

If oil adheres, it may weaken the strength of screwed part.

Do not tighten flare nuts too much.

If a flare nut cracks, the refrigerant may leak.

- If there is no torque wrench, use Table 3 as a rule of thumb.
When tightening the flare nut with a spanner harder and harder, there is a point where the tightening torque suddenly increases.
From that position, tighten the nut additionally the angle shown in Table 3.
After the work is finished, check securely that there is no gas leak.
If the nut is not tightened as instructed, it may cause slow refrigerant leak and result in malfunction (such as does not cool or heat).

Table 3

Piping size [in. (mm)]	Tightening angle	Recommended arm length of tool used [in. (mm)]
φ 3/8 (9.5)	60° – 90°	Approx. 8 (200)
φ 5/8 (15.9)	30° – 60°	Approx. 12 (300)

CAUTION

Insulation of field piping must be carried out up to the connection inside the flare nut of the air conditioner.

If the piping is exposed to the atmosphere, it may cause sweating, burn due to touching the piping, electric shock or fire due to the wiring touching the piping.

- After leak test, referring to **Fig. 12**, insulate both the gas and liquid piping connection with the attached joint insulating material (8) and (9) to prevent the piping from getting exposed. Then, tighten the both ends of insulating material with the clamp (4).
- Wrap the sealing material (Medium-1, 2) (11) (12) around the joint insulating material (8) and (9) (flare nut section), both the gas and liquid piping.
- Make sure to bring the seam of joint insulating material (8) and (9) to the top.

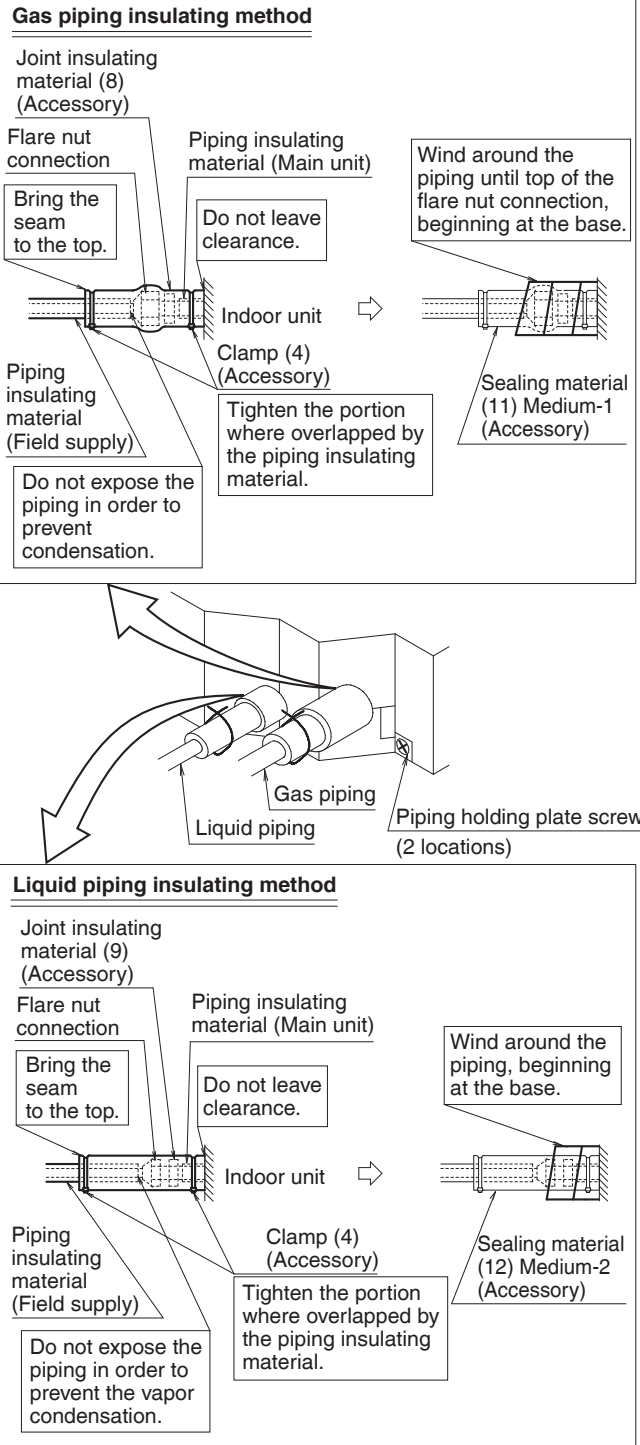
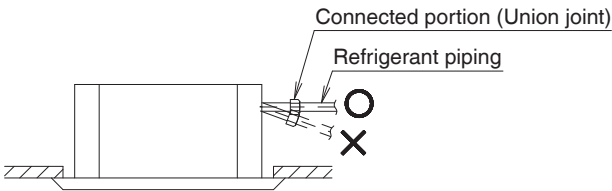

Fig. 12

- Before brazing refrigerant piping, have nitrogen flow through the refrigerant piping and substitute air with nitrogen (NOTE 1) (Refer to Fig. 13). Then, carry out brazing (NOTE 2). After all the brazing works are finished, carry out flare connection with the indoor unit. (Refer to Fig. 12)

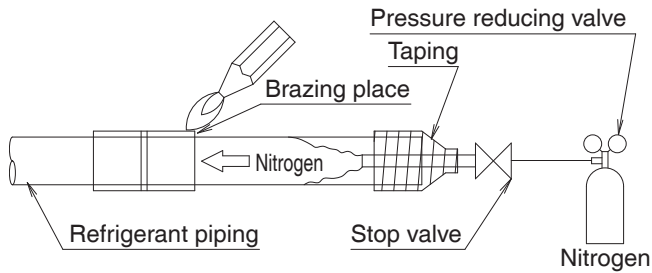

Fig. 13

CAUTION

- Nitrogen, not R32 refrigerant gas, must be used for gas displacement in the piping before brazing work. (Non-compliance may result in fire.)
- When using a brazing torch, check that there are no refrigerant leaks using a refrigerant leak detector.
- In the event of a refrigerant leakage during brazing work, immediately turn off the torch and any other sources of fire.

NOTE

1. The proper pressure for having nitrogen flow through the piping is approximately 2.9 psi (0.02 MPa), a pressure that makes one feel like breeze and can be obtained through a pressure reducing valve.
2. Do not use flux when brazing refrigerant piping. Use phosphor copper brazing filler metal (BCuP-2: B-Cu93P-710/795: ISO 3677) that does not require flux. (If chlorinated flux is used, the piping will be corroded and, in addition if fluorine is contained, the refrigerant oil will be deteriorated and the refrigerant circuit will be affected badly.)
3. When carrying out leak test of refrigerant piping and the indoor unit after the installation of indoor unit is finished, confirm the connecting outdoor unit installation manual for test pressure. Refer to the outdoor unit installation manual or technical document for refrigerant piping.
4. In case of refrigerant shortage due to forgetting additional refrigerant charge etc., it will result in malfunctions such as not cooling or heating. Refer to the outdoor unit installation manual or technical document for refrigerant piping.

CAUTION

Do not use antioxidant when brazing piping.
It may result in malfunction of components and clogging of piping due to residue.

6. DRAIN PIPING WORK

(1) Carry out drain piping.

- Carry out drain piping so that drainage can be ensured.
- Select the piping diameter equal to or larger than (except for riser) that of the connection piping (PVC, nominal diameter 1 in. (25 mm), outside diameter 1-1/4 in. (32 mm)).
 - Install the drain piping as short as possible with downward inclination of 1/100 or more where air cannot stagnate. (Refer to Fig. 14) Bubbling sound may occur.

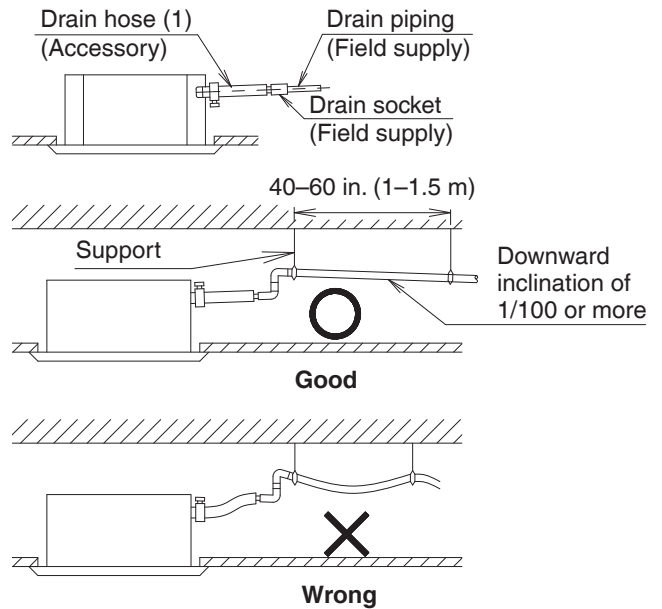

Fig. 14

CAUTION

If drainage stagnates in the drain piping, the piping may get clogged.
(Components contained in silver-based antibacterial agents may precipitate out and adhere to the drain piping.)

- If sufficient downward inclination cannot be ensured, carry out upward drain piping.
- Install supports at a distance of 40–60 in. (1–1.5 m) so that the piping may not deflect. (Refer to Fig. 14)
- Make sure to use the attached drain hose (1) and the metal clamp (2). Insert the drain hose (1) into the drain socket up to the point where the socket diameter becomes larger. Put the metal clamp (2) to the taped hose end and tighten the metal clamp (2) with torque 1.00±0.11 lbf-ft. (1.35±0.15 N·m).

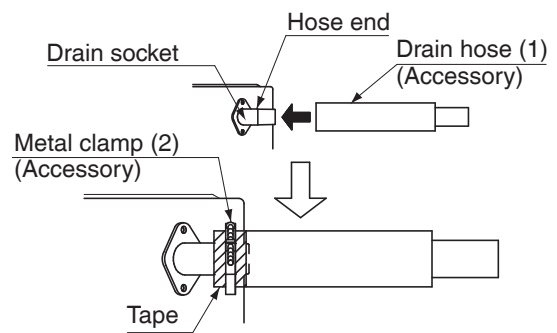
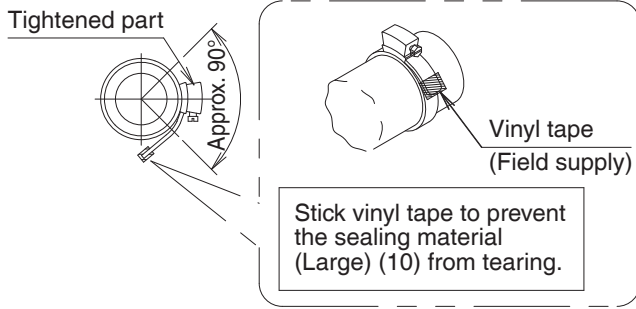

Fig. 15

CAUTION

- Do not tighten the metal clamp (2) with the torque more than the specified value. The drain hose (1), the socket or the metal clamp (2) may be damaged.
- Wrap vinyl tape around the end of the metal clamp (2) so that the sealing material (Large) (10) to be used at the next process may not be damaged with the clamp end or bend the tip of the metal clamp (2) inward as shown. (Refer to Fig. 16)

<In case of sticking vinyl tape>



<In case of bending the tip>

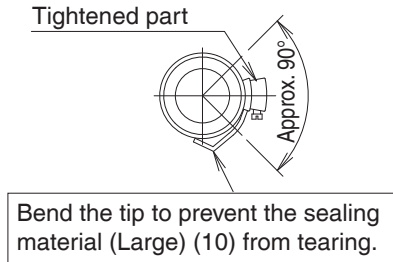

Fig. 16

< Caution to be taken when carrying out upward drain piping (Refer to Fig. 17) >

- The maximum height of the drain riser is 26-9/16 in. (675 mm). Since the drain pump mounted on this indoor unit is a high head type, from the characteristic point of view, the higher the drain riser the lower the draining noise. Therefore, the drain riser of 11-13/16 in. (300 mm) or higher is recommended.
- For upward drain piping, keep the horizontal piping distance of 11-13/16 in. (300 mm) or less between the drain socket root to the drain riser.

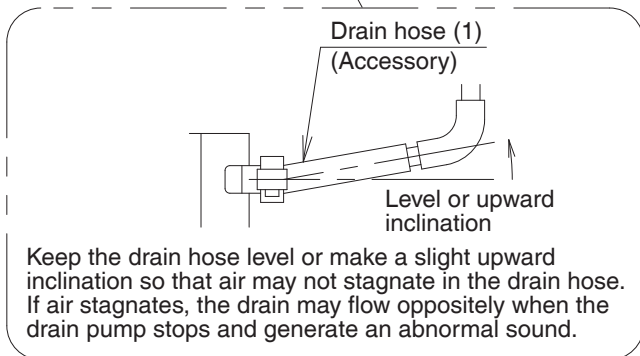
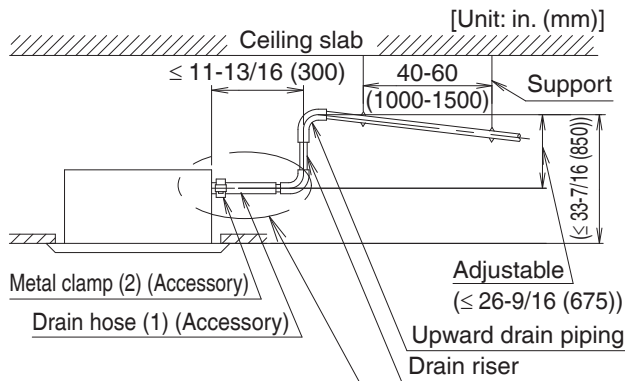

Fig. 17

CAUTION

- Do not apply excessive force to the attached drain hose (1) by bending or twisting it. This could cause water leakage.
- In case of centralized drain piping, carry out piping work according to the procedure shown in the following Fig. 18.

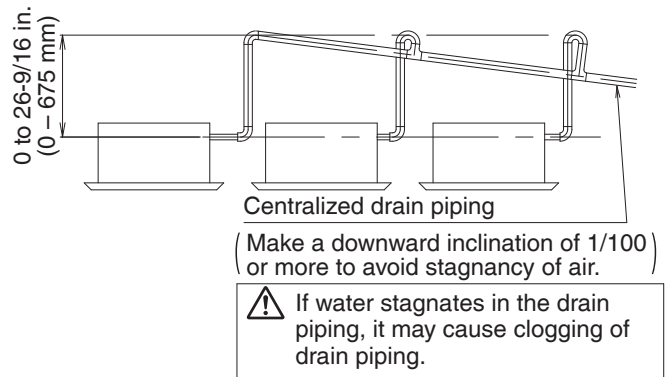

Fig. 18

- Select a size for the centralized drain piping that meets the capacity of indoor units to be connected. Refer to the technical document.
- When installing the new indoor unit, use the attached new drain hose (1) and the metal clamp (2). If an old drain hose or a metal clamp is used, it may cause water leakage.

(2) After piping work is finished, check if the drain flows smoothly.

[When the electric wiring work is finished]

- Gradually pour 1/4 gal. (1 ℓ) of water from the air outlet on the left side of the drain socket into the drain pan using caution to avoid splashing water on the electric components such as the drain pump. Confirm drainage by operating the indoor unit under cooling mode according to 9. FIELD SETTING and 10. TEST OPERATION. (Refer to Fig. 19)

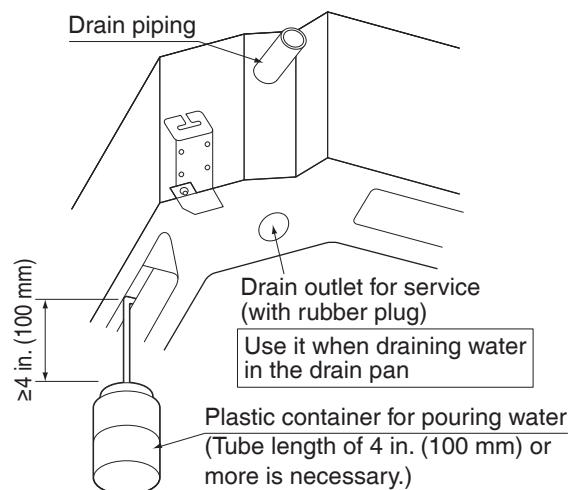

[Method of adding water]

Fig. 19

- After checking the drainage of water, refer to **Fig. 20** and attach the sealing material (14) to perform the thermal insulation of the drain socket.

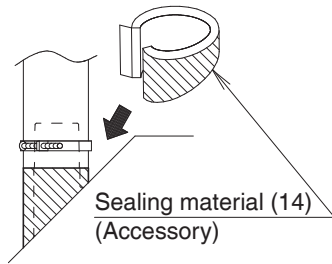

Fig. 20

[When the electric wiring work is not finished]

- The electric wiring works (including ground) must be carried out by a qualified electrician.
- If a qualified person is not present, after the electric wiring work is finished, check the drainage according to the method specified in **[When the electric wiring work is finished]**.

1. Open the control box cover and connect the single phase 208/230 V power supply to the terminal (L₁, L₂) on the terminal block (X2M).
Connect the ground wiring to the ground terminal.
(Refer to Fig. 21)

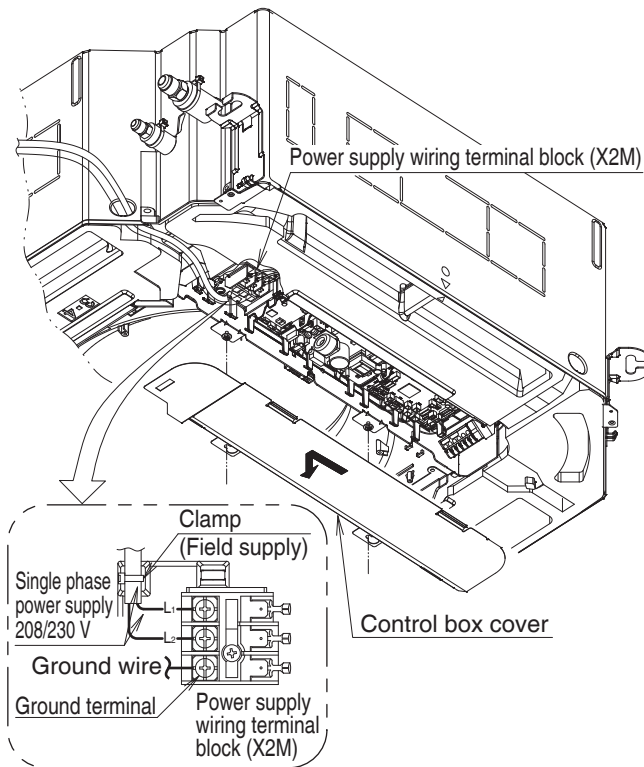

Fig. 21

2. Make sure the control box cover is closed before turning on the power supply.
 - Throughout the whole process, carry out the work using caution with wiring around the control box so that the connectors do not come off.
3. Gradually pour 1/4 gal. (1 ℓ) of water from the air outlet on the left side of the drain socket into the drain pan using caution to avoid splashing water on the electric components such as the drain pump. **(Refer to Fig. 19)**

4. When the power supply is turned on, the drain pump will operate. Drainage can be checked at the transparent part of the drain socket.
(The drain pump will automatically stop after 10 minutes.)

After checking the drainage of water, refer to **Fig. 20** and attach the sealing material (14) to perform the thermal insulation of the drain socket.

- Do not connect the drain piping directly to the sewage that gives off ammonia odor.
The ammonia in the sewage may go through the drain piping and corrode the heat exchanger of the indoor unit.
- Do not apply external force to the float switch or it could cause malfunction.

5. Turn off the power supply after checking drainage and remove the power supply wiring.
6. Attach the control box cover as before.
 - Do not touch the electronic parts other than the terminal block (X2M).

(3) Sweating may occur and result in water leakage. Therefore, make sure to insulate the indoor drain piping and socket locations.

After drainage is checked, put the attached sealing material (14) referring to **Fig. 20**, and insulate the drain hose (1) and the metal clamp (2) with the attached sealing material (Large) (10) referring to **Fig. 22**.

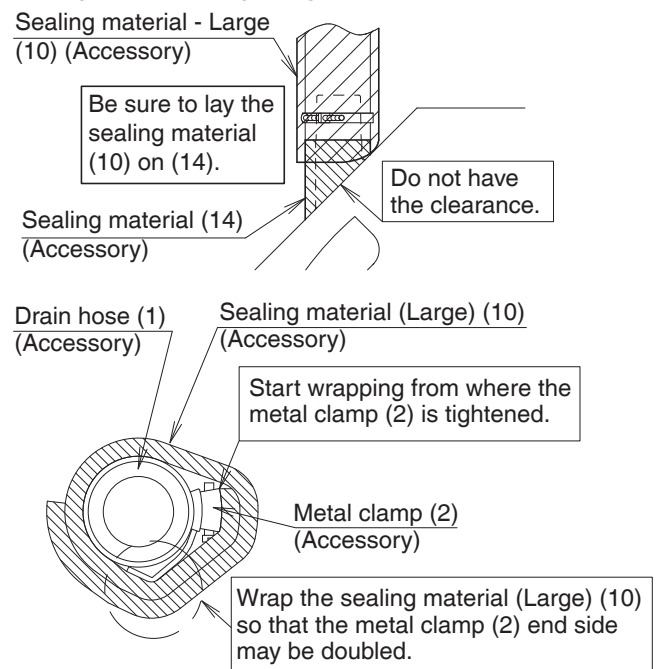

Fig. 22

7. ELECTRIC WIRING WORK

7-1 GENERAL INSTRUCTIONS

- Make sure that all electric wiring work is carried out by qualified personnel according to the applicable legislation and this installation manual, using a separate dedicated circuit. Insufficient capacity of the power supply circuit or improper electrical construction may lead to electric shock or a fire.
- Means for full disconnection under overvoltage category III conditions must be incorporated in the fixed wiring according to national wiring rules.
- Do not turn on the power supply (branch switch, branch over-current circuit breaker) until all the works are finished.

- Make sure to ground the air conditioner. Grounding resistance should be according to applicable legislation.
- Do not connect the ground wiring to gas or water piping, lightning conductor or telephone ground wiring.
 - Gas piping ... Ignition or explosion may occur if gas leaks.
 - Water piping... Hard vinyl tubes are not effective ground.
 - Lightning conductor or telephone ground wiring... Electric potential may rise abnormally if struck by a lightning bolt.
- For electric wiring work, refer to also the WIRING DIAGRAM attached to the control box cover.
- Carry out installation and wiring of the remote controller according to the installation manual attached to the remote controller.
- Do not touch the printed circuit board assemblies. It may cause malfunction.

7-2 ELECTRIC CHARACTERISTICS

Units				Power supply		Fan motor	
Model	Hz	Volts	Voltage range	MCA	MOP	HP	IDI
FCA18AAVJU	60	208/230	Max. 253 Min. 187	0.5	15	0.07 (53)	0.4
FCA24AAVJU				0.5	15	0.07 (53)	0.4
FCA30AAVJU				1.0	15	0.14 (106)	0.8
FCA36AAVJU				1.6	15	0.14 (106)	1.3
FCA42AAVJU				1.6	15	0.14 (106)	1.3
FCA48AAVJU				1.6	15	0.14 (106)	1.3

MCA: Minimum Circuit Ampacity (A)
 MOP: Maximum Overcurrent Protective Device (A)
 HP: Fan Motor Rated Output (HP (W))
 IDI: Inverter Drive Input (A)

7-3 SPECIFICATION FOR FIELD SUPPLY FUSES AND WIRING

Model	Power supply wiring		Remote controller wiring Transmission wiring	
	MOP ☐	Size	Wiring	Size
FCA18AAVJU	15A	Wiring size and length must comply with local codes.	2-conductor, stranded nonshielded copper cable PVC/vinyl jacket (NOTE 1)	AWG 18-16 (0.75-1.25 mm ²)
FCA24AAVJU				
FCA30AAVJU				
FCA36AAVJU				
FCA42AAVJU				
FCA48AAVJU				

Allowable lengths of remote controller wiring and transmission wiring are as follows:

- (1) Remote controller wiring
 - Length between indoor unit and remote controller Max. 1,640 ft. (500 m)
- (2) Transmission wiring
 - Total length Max. 6,560 ft. (2,000 m)
 - Length between units Max. 656 ft. (200 m)
 - Farthest length*¹ (10 systems*² or less) Max. 3,280 ft. (1,000 m)
 - Farthest length*¹ (more than 10 systems*²) Max. 2,296 ft. (700 m)

*¹ Length from outdoor unit to farthest unit

*² System : A set of units connected in the same refrigerant circuit

NOTE

1. Vinyl cord with sheath or cable (Insulated thickness : 1/16 in. (1 mm) or more)

7-4 WIRING CONNECTION METHOD

⚠ CAUTION FOR POWER SUPPLY WIRING AND GROUND WIRING

- For connection to the terminal block, use ring type crimp style terminals with insulation sleeve or insulate the wirings properly.

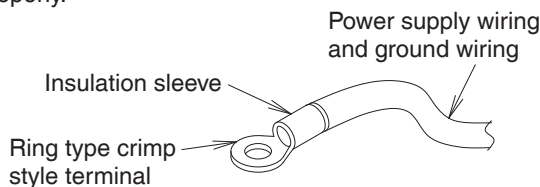

- Use the required wires, connect and fix securely so that external force may not apply to the terminals.
- Use a proper screw driver for tightening the terminal screws. If an improper screw driver is used, it may damage the screw head and a proper tightening cannot be carried out.
- If a terminal is over tightened, it may be damaged. Refer to the table below for tightening torque of terminals.

	Tightening torque [lbf-ft. (N·m)]
Terminal block for remote controller and transmission wiring	0.65 ± 0.06 (0.88 ± 0.08)
Terminal for power supply wiring	1.08 ± 0.10
Ground terminal	(1.47 ± 0.14)

- Do not carry out soldering finish when stranded wirings are used.

⚠ WARNING

- When wiring, form the wiring orderly to prevent it from being sandwiched by the control box cover and fasten the cover securely. Improper position of the control box cover may result in electric shock or fire.

< Power supply wiring · ground wiring · remote controller wiring · transmission wiring connecting method >

- Power supply wiring, ground wiring
 Pass the power supply wire through the attached insulation tube (16) between the outlet of conduit and the power supply terminal, and bind them together with the attached clamp (4). **(Refer to Fig. 23-2)**
 Use a pair of conduit mounting plates (17) to connect a conduit to the unit as shown **Fig. 23-1**. After connecting the power supply wiring to [L₁ · L₂] on the power supply terminal block (X2M) and the ground wiring to the ground terminal, clamp them near the terminal block using the attached clamp (4). **(Refer to Fig. 23-2)**
- Remote controller wiring, transmission wiring
 Pull the wiring through the wiring through hole (low voltage). After connecting the remote controller wiring to [P1 · P2] and the transmission wiring to [H1 · H2] on the terminal block (X1M), clamp them near the terminal block using the attached clamp (4). **(Refer to Fig. 23-2)**
- After connecting the wiring, make sure to stick the sealing material (Small) (13) to the wiring through hole to prevent water from entering the indoor unit. **(Refer to Fig. 24)**

⚠ CAUTION

- Never connect the power supply wiring to the terminal block for remote controller/transmission wiring (X1M). If may damage the total system.
- Do not connect the remote controller/transmission wiring to the wrong terminal block.

- Use a 90° elbow type of conduit with dimensions **Fig. 23-1** to prevent it from hitting the swing motor housing of decoration panel.
- Do not dispose the screw which assembles casing and resin together. The screw will be used to install conduit mounting plate. Make sure to install the conduit mounting plate first before wiring.

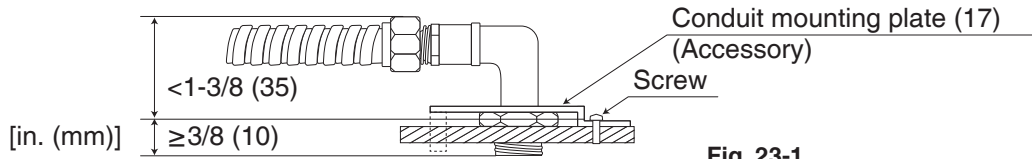

Fig. 23-1

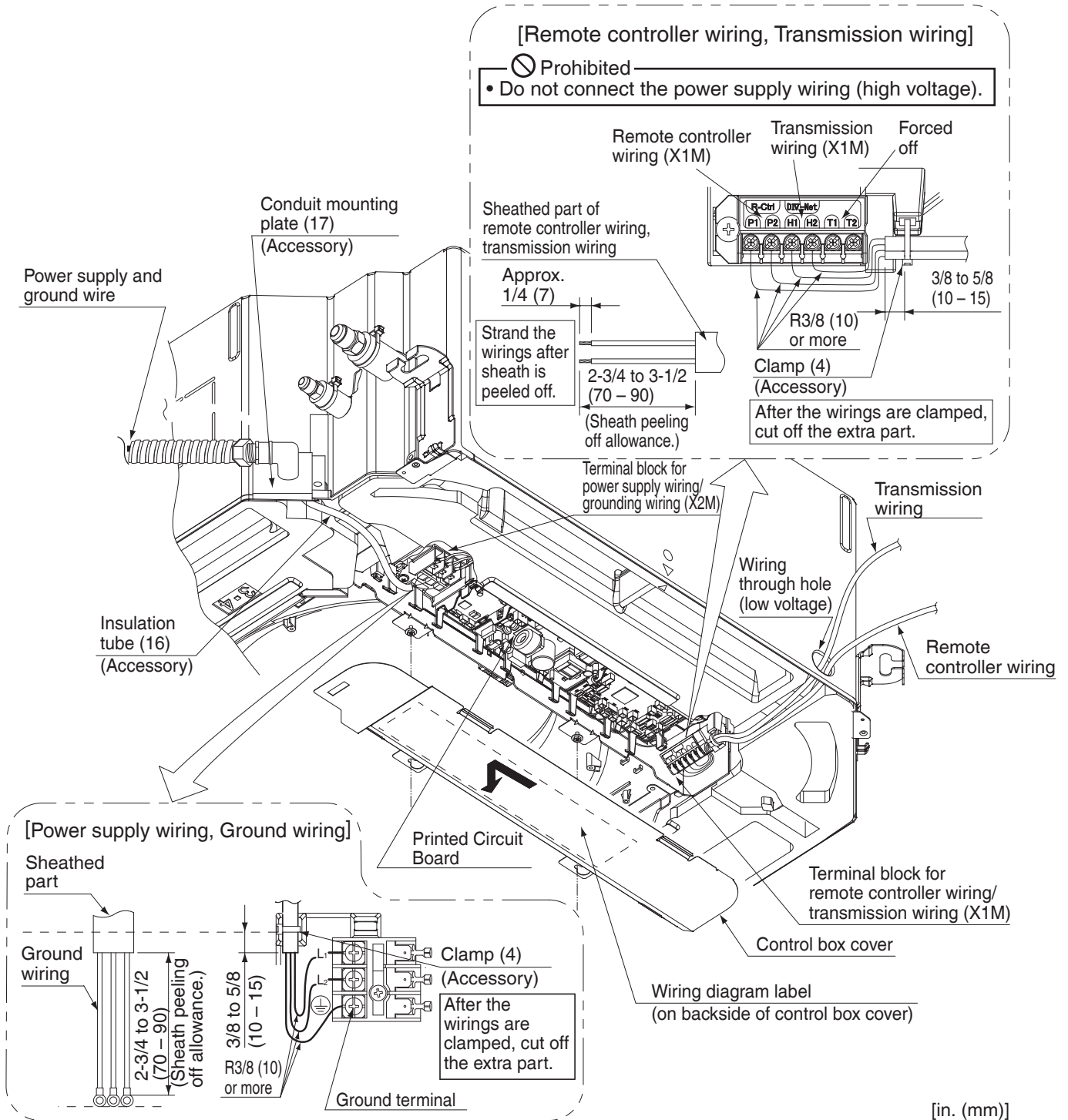

Fig. 23-2

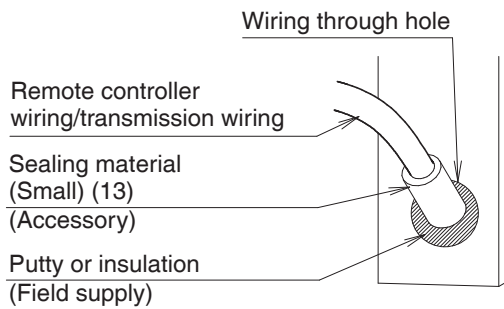

Fig. 24

<<Mending method of wiring through hole>>

- After wiring connection is finished, to prevent the penetration of water, small animals and insects into the indoor unit from the outside, mend the respective covers for wiring through hole for the power supply wiring/ground wiring and the remote controller wiring/transmission wiring.
- Cut the sealing material (Small) (13) into two pieces and wrap each wiring with each piece.
- Seal the clearance around the wirings with putty and insulating material (field supply).
If insects and small animals get into the indoor unit, short circuiting may occur inside the control box.
- Keep the distance of 2 in. (50 mm) or more between low voltage wiring (remote controller wiring, transmission wiring) and the high voltage wiring (power supply wiring, ground wiring) at anywhere outside the indoor unit. If both wirings are laid down together, they may be affected by outside electrical noise and cause malfunction or failure.

7-5 EXAMPLE OF WIRING

< No. 1 system: When using 1 remote controller (Normal operation) >

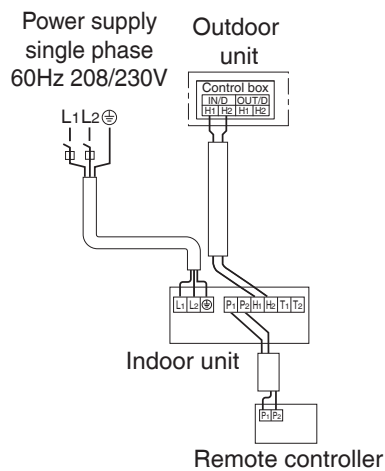

Fig. 25

< No. 2 system: When using 2 remote controllers >

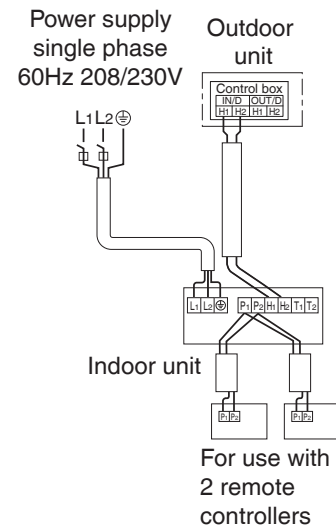

Fig. 26

[PRECAUTIONS]

1. Do not ground the equipment on gas pipes, water pipes or lightning rods, or crossground with telephones. Improper grounding could result in electric shock.

7-6 FOR CONTROL WITH 2 REMOTE CONTROLLERS (TO CONTROL 1 INDOOR UNIT WITH 2 REMOTE CONTROLLERS)

- For control with 2 remote controllers, set one remote controller as Main and the other remote controller as Sub.

< Changeover method from Main to Sub and vice versa >

Refer to the installation manual attached to the remote controller.

< Wiring method >

- (1) Remove the control box cover.
- (2) Carry out additional wiring from the remote controller 2 (Sub) to the terminals (P1, P2) for remote controller wiring on the terminal block (X1M) in the control box.

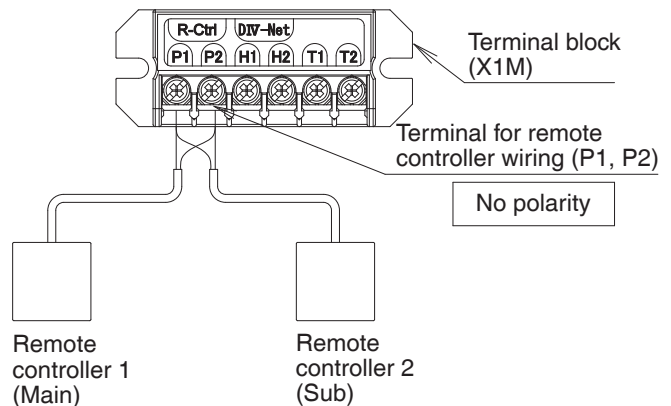

7-7 FOR CENTRALIZED CONTROL

- When centralized equipment (such as centralized controller) is used for control, it is required to set the group No. on the remote controller.
For details, refer to the manuals attached to the centralized equipment.
- Connect the centralized equipment to the indoor unit connected to the remote controller.

7-8 FOR REMOTE CONTROL (FORCED OFF OR ON / OFF OPERATION)

(1) Wiring method and specification

- Remote control is available by connecting the external input to the terminal T1 and T2 on the terminal block for remote controller and transmission wiring (X1M).

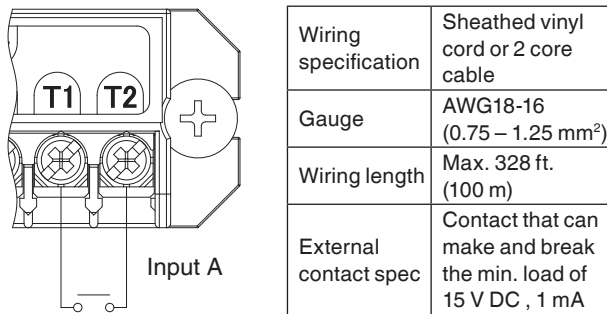

(2) Actuation

- Input A of FORCED OFF and ON/OFF OPERATION will be as the table shown below.

	Input A = ON	Input A = OFF
In case of FORCED OFF	Remote controller prohibited	Remote controller permitted
In case of ON/OFF OPERATION	Operation	Stop

(3) How to choose FORCED OFF or ON/OFF OPERATION

- For choosing FORCED OFF or ON/OFF OPERATION, setting by remote controller is required.
(Refer to 9. FIELD SETTING and 10. TEST OPERATION.)

8. MOUNTING DECORATION PANEL

<<If test operation is required before mounting the decoration panel, 9. FIELD SETTING and 10. TEST OPERATION can be carried out before 8. MOUNTING DECORATION PANEL.>>

If carrying out test operation before attaching the decoration panel, be sure to take measures against short circuit first (separate air outlet and air inlet by placing cardboard and the like in between) to avoid any risk of condensation in the indoor unit, and finish the test promptly (approx. 1 hour).

Refer to the installation manual attached to the decoration panel.

- After the decoration panel is mounted, check if no clearance exists between the panel and the unit.
- If test operation is carried out before mounting the decoration panel, check the horizontal blade action after the panel is mounted.

9. FIELD SETTING

<<Refer to also the installation manual attached to the outdoor unit.>>

— ⚠ CAUTION —

Before carrying out field setting, check the items mentioned in Clause 1: **(1) Items to be checked after the installation work is completed** on page 1. Check if all the installation and piping works for the air conditioner are completed.

- Check if the control box cover of the air conditioner is closed.

< FIELD SETTING >

<<After turn on the power supply, carry out field setting from the remote controller according to the installation state.>>

- Carry out setting at 3 places, MODE NO., FIRST CODE NO. and SECOND CODE NO..
The settings shown by in the table indicate those when shipped from the factory.
- The method of setting procedure and operation is shown in the installation manual attached to the remote controller.
(Note) Though setting of MODE NO. is carried out as a group, if you intend to carry out individual setting by each indoor unit or confirmation after setting, carry out setting with the MODE NO. shown in the parenthesis ().
- In case of remote control, for changeover of input to FORCED OFF or to ON/OFF OPERATION.
[1] Enter into the field setting mode with the remote controller.
[2] Select MODE NO. **12**.
[3] Set the FIRST CODE NO. to **1**.
[4-1] For FORCE OFF, set the SECOND CODE NO. to **01**.
[4-2] For ON/OFF OPERATION, set the SECOND CODE NO. to **02**.
(It is set to FORCE OFF when shipped from the factory.)
- Ask your customer to keep the manual attached to the remote controller together with the operation manual.
- Do not carry out settings other than those shown in the table.

9-1 SETTING CEILING HEIGHT

- Set the SECOND CODE NO. according to the ceiling height as shown in the Table 4.

Table 4

Setting	Ceiling height [ft. (m)]		MODE NO.	FIRST CODE NO.	SECOND CODE NO.
	18 · 24 type	30 · 36 · 42 · 48 type			
Standard	≤ 8-3/4 (≤ 2.7)	≤ 10-1/2 (≤ 3.2)	13 (23)	0	01
High ceiling 1	8-3/4 to 10 (2.7 to 3.0)	10-1/2 to 12 (3.2 to 3.6)			02
High ceiling 2	10 to 11-1/2 (3.0 to 3.5)	12 to 13-3/4 (3.6 to 4.2)			03

9-2 SETTING AIR DISCHARGE DIRECTION

- Refer to the installation manual attached to the sealing material of air discharge outlet sold separately and engineering data book, for ceiling height settings for four-direction (part of corner closed off) and three-direction.
(The SECOND CODE NO. is factory set to **01** (all round outlet) before shipping.)

9-3 SETTING WHEN AN OPTIONAL ACCESSORY IS ATTACHED

- For setting when attaching an optional accessory, refer to the installation manual attached to the optional accessory.

9-4 SETTING FAN SPEED DURING THERMOSTAT OFF

- Set the fan speed according to the using environment after consultation with your customer.
- When the fan speed is changed, explain the set fan speed to your customer.

Table 5

Setting		MODE NO.	FIRST CODE NO.	SECOND CODE NO.
Fan speed during cooling thermostat OFF	LL (Extra low) Setting	12 (22)	6	01
				02
Fan speed during heating thermostat OFF	LL (Extra low) Setting	12 (22)	3	01
				02

9-5 SETTING FILTER SIGN

- A message to inform the air filter cleaning time will be indicated on the remote controller.
- Set the SECOND CODE NO. shown in the Table 6 according to the amount of dust or pollution in the room.
- Though the indoor unit is equipped with the long life filter, it is necessary to periodically clean the filter to avoid clogging of the filter. Please also explain the set time to the customer.
- The periodic filter-cleaning time can be shortened depending on the environment.

Table 6

Contamination	Hours until indication	MODE NO.	FIRST CODE NO.	SECOND CODE NO.
Normal	Approx. 2,500 hrs	10 (20)	0	01
More contaminated	Approx. 1,250 hrs			02
With indication			3	01
No indication*				02

* Use **No indication** setting when cleaning indication is not necessary such as the case of periodical cleaning being carried out.

9-6 SETTING THERMOSTAT DIFFERENTIAL

- For setting when remote sensor is used, change over thermostat differential.

Table 7

Differential	MODE NO.	FIRST CODE NO.	SECOND CODE NO.
1.8°F (1°C)	12 (22)	2	01
0.9°F (0.5°C)			02

9-7 SETTING AIR DISCHARGE DIRECTION

- When changing air discharge setting (2-way or 3-way air discharge), set the SECOND CODE NO. as shown in the Table 8.

Table 8

Setting	MODE NO.	FIRST CODE NO.	SECOND CODE NO.
4-way air discharge	13 (23)	1	01
3-way air discharge			02
2-way air discharge			03

9-8 DRY MODE SETTING

Table 9

Setting		MODE NO.	FIRST CODE NO.	SECOND CODE NO.
Dry mode set temperature	Room temperature	11 (21)	12	01
	Same as cooling mode set temperature			02

10. TEST OPERATION

- After cleaning the indoor unit inside, carry out test operation according to installation manual attached to the outdoor unit.
- If the test operation is completed with no malfunction code shown on the remote controller, the system is confirmed to be ready for activating safety measures when refrigerant is detected by the built-in refrigerant sensor.
- When the remote controller operation lamp flashes, it shows that something is abnormal.
Check the malfunction codes on the remote controller.
The relation between the malfunction codes and malfunction details is described in the operation manual attached to the outdoor unit.
Particularly, if the indication is one of those shown in the Table 10, it may be an error in the electrical wiring or the power supply is disconnected. Therefore, recheck wiring.

Table 10

Remote controller indication	Details
Though the centralized control is not carried out, the indicating the central control turns on.	<ul style="list-style-type: none"> The terminals (T1 · T2) for FORCED OFF on the indoor unit transmission terminal block is short circuited.
[U4] displays. [UH] displays.	<ul style="list-style-type: none"> The power supply to the outdoor unit is not made. The power supply work to the outdoor unit is not carried out. The transmission wiring and the remote controller wiring and FORCED OFF wiring are connected incorrectly. The transmission wiring is disconnected.
No indication	<ul style="list-style-type: none"> The power supply to the indoor unit is not made. The power supply work to the indoor unit is not carried out. The remote controller wiring and the transmission wiring and FORCED OFF wiring are connected incorrectly. The remote controller wiring is disconnected.

- At test operation, install the decoration panel and check the actuation of the horizontal blade.

NOTE 

When performing the test operation, always attach the decoration panel. Otherwise, this may cause condensation.

**CAUTION**

After test operation is completed, check the items mentioned in Clause 2: **(2) Items to be checked at time of delivery** on page 2.

If the interior finish work is not completed when the test operation is finished, for protection of the air conditioner, ask the customer not to operate the air conditioner until the interior finish work is completed.

If the air conditioner is operated, the inside of the indoor units may be polluted by substances generated from the coating and adhesives used for the interior finish work and cause water splash and leakage.

**To the operator carrying out test operation**

After test operation is completed, before delivering the air conditioner to the customer, confirm that the control box cover, the air filter and suction grille are attached.

In addition, explain the power supply status (power supply ON/OFF) to the customer.

DAIKIN COMFORT TECHNOLOGIES MANUFACTURING, L.P.

Daikin Texas Technology Park,
19001 Kermier Road,
Waller, TX, 77484, U.S.A.

