



# UPFLOW/DOWNFLOW COILS

## INSTALLATION INSTRUCTIONS

### 1. Important Safety Instructions

The following symbols and labels are used throughout this manual to indicate immediate or potential safety hazards. It is the owner's and installer's responsibility to read and comply with all safety information and instructions accompanying these symbols. Failure to heed safety information increases the risk of personal injury, property damage, and/or product damage.

**WARNING**



**HIGH VOLTAGE!**  
DISCONNECT ALL POWER BEFORE SERVICING OR INSTALLING THIS UNIT. MULTIPLE POWER SOURCES MAY BE PRESENT. FAILURE TO DO SO MAY CAUSE PROPERTY DAMAGE, PERSONAL INJURY OR DEATH.

**WARNING**

ONLY PERSONNEL THAT HAVE BEEN TRAINED TO INSTALL, ADJUST, SERVICE OR REPAIR (HEREINAFTER, "SERVICE") THE EQUIPMENT SPECIFIED IN THIS MANUAL SHOULD SERVICE THE EQUIPMENT. THE MANUFACTURER WILL NOT BE RESPONSIBLE FOR ANY INJURY OR PROPERTY DAMAGE ARISING FROM IMPROPER SERVICE OR SERVICE PROCEDURES. IF YOU SERVICE THIS UNIT, YOU ASSUME RESPONSIBILITY FOR ANY INJURY OR PROPERTY DAMAGE WHICH MAY RESULT. IN ADDITION, IN JURISDICTIONS THAT REQUIRE ONE OR MORE LICENSES TO SERVICE THE EQUIPMENT SPECIFIED IN THIS MANUAL, ONLY LICENSED PERSONNEL SHOULD SERVICE THE EQUIPMENT. IMPROPER INSTALLATION, ADJUSTMENT, SERVICING OR REPAIR OF THE EQUIPMENT SPECIFIED IN THIS MANUAL, OR ATTEMPTING TO INSTALL, ADJUST, SERVICE OR REPAIR THE EQUIPMENT SPECIFIED IN THIS MANUAL WITHOUT PROPER TRAINING MAY RESULT IN PRODUCT DAMAGE, PROPERTY DAMAGE, PERSONAL INJURY OR DEATH.

### 2. Shipping Inspection

Upon receiving the product, inspect it for damage from shipment. Shipping damage, and subsequent investigation is the responsibility of the carrier. Verify the model number, specifications, and accessories are correct prior to installation. The distributor or manufacturer will not accept claims from dealers for transportation damage or installation of incorrectly shipped units.

#### 2.1 Handling

Use caution when transporting / carrying unit.. Do not carry unit with hooks or sharp object. The preferred method of carrying the unit after arrival at the job site is to carry by two-wheel hand truck from the back or sides or by hand by carrying at the cabinet corners.

### 3. Codes & Regulations

This product is designed and manufactured to comply with national codes. Installation in accordance with such codes and/or prevailing local codes/regulations is the responsibility of the installer. The manufacturer assumes no responsibility for equipment installed in violation of any codes or regulations.

The United States Environmental Protection Agency (EPA) has issued various regulations regarding the introduction and disposal of refrigerants. Failure to follow these regulations may harm the environment and can lead to the imposition of substantial fines. Should you have any questions please contact the local office of the EPA.

### 4. Replacement Parts

Inspect the unit to verify all required components are present and intact. Report any missing components immediately to the manufacturer or to the distributor. Make sure to include the full product model number and serial number when reporting and/or obtaining service parts. Replacement parts for this product are available through your contractor or local distributor. For the location of your nearest distributor consult the white business pages, the yellow page section of the local telephone book or contact:

HOMEOWNER SUPPORT  
GOODMAN MANUFACTURING COMPANY, L.P.  
19001 KERMIER ROAD  
WALLER, TEXAS 77484  
877- 254 - 4729

### 5. Pre-Installation Instructions

#### 5.1 Preparation

Keep this document with the unit. Carefully read all instructions for the installation prior to installing product. Make sure each step or procedure is understood and any special considerations are taken into account before starting installation. Assemble all tools, hardware and supplies needed to complete the installation. Some items may need to be purchased locally. Make sure everything needed to install the product is on hand before starting.

#### 5.2 Clearances

Refrigerant lines must be routed depending on configuration of unit to maintain the required 24" minimum clearance for service. Consult all appropriate regulatory codes prior to determining final clearances. In installations that may lead to physical damage (i.e. a garage) it is advised to install a protective barrier to prevent such damage. Always install units such that a positive slope in condensate line (1/4" per foot) is allowed.

### 6. Application Information

Coils are designed for indoor installation only and must be installed downstream (discharge air) of the furnace. The CAPF/CAPT product line may be installed in upflow or downflow orientations.



## 7. Condensate Drain Piping

In all cooling applications where condensate overflow may cause damage, a secondary drain pan must be provided by the installer and placed under the entire unit with a separate drain line properly sloped and terminated in an area visible to the owner. This secondary drain pan can provide extra protection to the area under the unit should the primary drain plug up and overflow. As expressed in our product warranty, we will not be liable for any damages, structural or otherwise due to the failure to follow this installation requirement.

Condensate drain connections are located in the drain pan at the bottom of the coil/enclosure assembly. Use the female (3/4" FPT) threaded fitting that protrudes outside of the enclosure for external connections. The connectors required are 3/4" NPT male, either PVC or metal pipe, and must be hand tightened to a torque of no more than 37 in-lbs. to prevent damage to the drain pan connection. An insertion depth between .36 to .49 inches (3-5 turns) should be expected at this torque.

1. Ensure drain pan hole is NOT obstructed.
2. To prevent potential sweating and dripping on finished space, it may be necessary to insulate the condensate drain line located inside the building. Use Armaflex® or similar material.

A Secondary Condensate Drain Connection, now called for by many building codes, has been provided. Pitch the drain line 1/4" per foot to provide free drainage. Provide required support to drain line to prevent bowing. Install a condensate trap in the primary drain line to ensure proper drainage. If the secondary drain line is required, run the line separately from the primary drain and end it where condensate discharge can be easily seen.

### CAUTION

IF SECONDARY DRAIN IS NOT INSTALLED, THE SECONDARY ACCESS MUST BE PLUGGED.

## 8. Refrigerant Lines

### CAUTION

THE COIL IS SHIPPED UNDER PRESSURE WITH AN R-410A GAS MIXTURE. USE APPROPRIATE SERVICE TOOLS AND FOLLOW THESE INSTRUCTIONS TO PREVENT INJURY.

### WARNING

A QUENCHING CLOTH IS STRONGLY RECOMMENDED TO PREVENT SCORCHING OR MARRING OF THE EQUIPMENT FINISH WHEN BRAZING CLOSE TO THE PAINTED SURFACES. USE BRAZING ALLOY OF 5% MINIMUM SILVER CONTENT.

**NOTE:** Refrigerant tubing must be routed to allow adequate access for servicing and maintenance of the unit.

Do not handle coil assembly with manifold or flowrator tubes. Doing so may result in damage to the tubing joints. Always use clean gloves for handling coil assemblies.

### 8.1 Tubing Size/Length

For the correct tubing size, follow the specification for the condenser/heat pump. Give special consideration to minimizing the length of refrigerant tubing when installing coils. Refer to Remote Cooling/Heat Pump Technical Publication TP-107\* Long Line Set Application R-410A for guidelines for line lengths over 80'. Leave a minimum 3" straight in line set from braze joints before any bends.

### 8.2 Tubing Preparation

All cut ends are to be round, burr free, and cleaned. Any other condition increases the chance of a refrigerant leak. Use a pipe cutter to remove the closed end of the spun closed suction line.

### 8.3 Brazing

Braze joints should be made only with the connections provided external to the cabinet. Do not alter the cabinet nor braze inside the cabinet. To avoid overheating after brazing, quench all brazed joints with water or a wet rag.

### CAUTION

APPLYING TOO MUCH HEAT TO ANY TUBE CAN MELT THE TUBE. TORCH HEAT REQUIRED TO BRAZE TUBES OF VARIOUS SIZES MUST BE PROPORTIONAL TO THE SIZE OF THE TUBE. SERVICE PERSONNEL MUST USE THE APPROPRIATE HEAT LEVEL FOR THE SIZE OF THE TUBE BEING BRAZED.

### 8.4 Special Instructions for Flowrator (Piston) Version

Coils in flowrator version are equipped with a check style flowrator for refrigerant management. For most installations with matching applications, no change to the flowrator piston is required. However, in mix-matched applications, a piston change may be required. See the piston kit chart or consult your local distributor for details regarding mix-matched piston sizing. If the mix-matched application requires a different piston size, change the piston in the distributor on the indoor coil before installing the coil and follow the procedure shown below.

### 8.5 Tubing Connections for Flowrator Model

1. Loosen the 13/16 nut **1 TURN ONLY** to allow high pressure tracer gas to escape. No gas indicates a possible leak.
2. After the gas has escaped, remove the nut and discard the plastic or brass cap.
3. Remove the check piston to verify it is correct and then replace the piston. See piston kit chart in instructions.
4. Use a tube cutter to remove the spin closure on the suction line. **DO NOT USE A CUTTING METHOD THAT WOULD RESULT IN THE GENERATION OF COPPER SHAVINGS OR COPPER DUST.**
5. Slide the 13/16 nut into place on the tailpiece supplied in the literature bag or with the unit.
6. Insert liquid line into the supplied tailpiece.

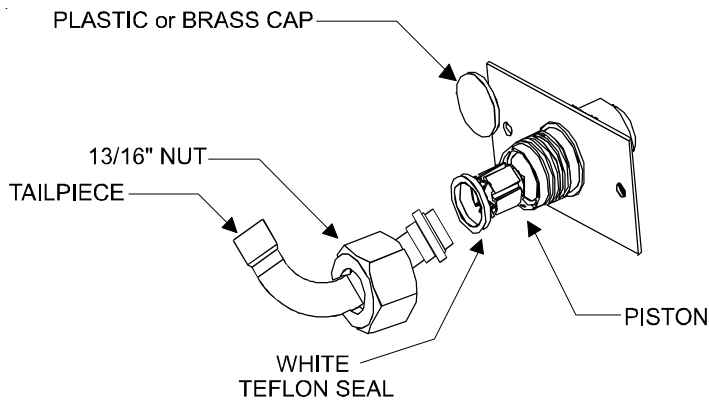

Figure 1

7. Insert the suction line into the connection, slide the insulation and the rubber grommet at least 18" away from the braze joint. Braze both liquid and suction line joints.
8. **AFTER THE TAILPIECE HAS COOLED**, confirm position of the white Teflon® seal and hand tighten the 13/16 nut.

**CAUTION**  
 EXCESSIVE TORQUE CAN CAUSE ORIFICES TO STICK. USE THE PROPER TORQUE SETTINGS WHEN TIGHTENING ORIFICES.

9. Torque the 13/16" nut to 10-20 ft-lbs. or 1/6 turn past hand tight.
10. Replace suction line grommet and insulation.

### 8.6 Tubing Connections for TXV Version

TXV models come with factory installed **non-adjustable TXV** with the bulb permanently located on the suction tube.

1. Remove coil access panel.
2. Remove access valve fitting cap and depress the valve stem in access fitting to release pressure. No pressure indicates possible leak.
3. Replace the refrigerant tubing panel.
4. Remove the spin closure on both the liquid and suction tubes using a tubing cutter. **DO NOT USE A CUTTING METHOD THAT WOULD RESULT IN THE GENERATION OF COPPER SHAVINGS OR COPPER DUST.**

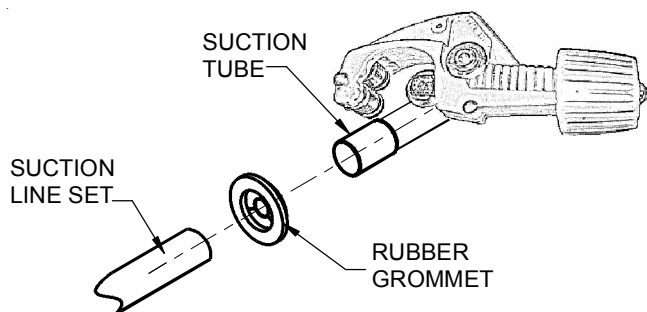

Figure 2.1

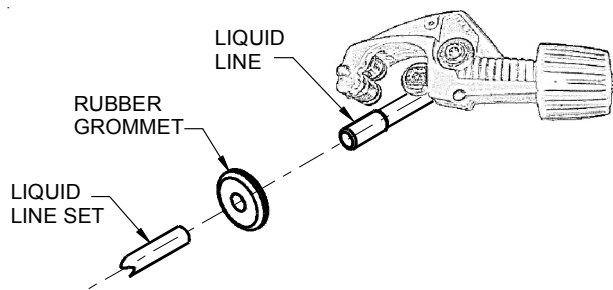

Figure 2.2

5. Insert liquid line set into liquid tube expansion and slide grommet about 18" away from braze joint.
6. Insert suction line set into suction tube expansion and slide insulation and grommet about 18" away from braze joint.
7. Braze suction and liquid line joints.

### 9. Top flanges can be bent for ease in installation to the duct flanges.

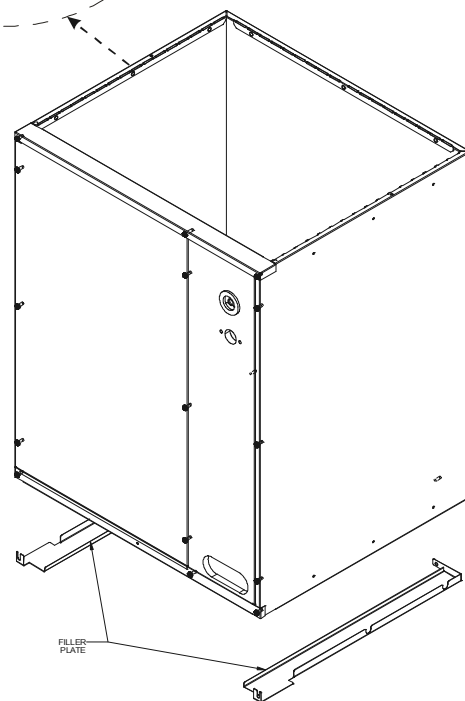
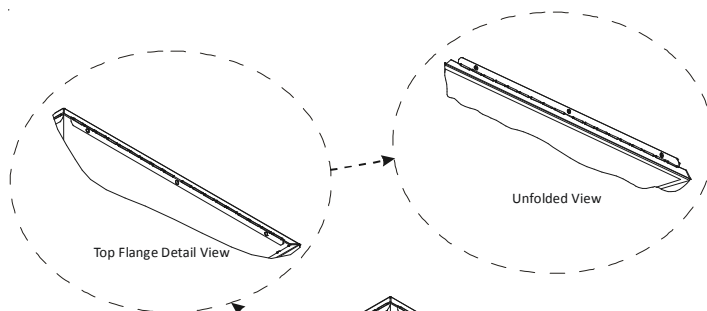

Figure 3

### 10. Filler Plates

Filler plates are supplied on all 17.5, 21, & 24.5 inch chassis to be used for adapting the unit to a furnace one size smaller. If the plenum and furnace openings are the same size, the filler plates must be removed. See Figure 3.

## 11. Plastic Drain Pan Application

### WARNING

DO NOT USE THE COIL PAN SHIPPED WITH THE UNIT ON OIL FURNACES OR ANY APPLICATION WHERE THE TEMPERATURE OF THE DRAIN PAN MAY EXCEED 300°F. A HIGH TEMPERATURE DRAIN PAN SUCH AS KITS HTP-A, -B, -C AND -D FOR NORMAL CABINET WIDTHS OF 14, 17.5, 21 AND 24.5 INCHES, RESPECTIVELY, SHOULD BE USED FOR APPLICATIONS WHERE THE TEMPERATURE EXCEEDS 300°F AND BELOW 450°F. A FIELD FABRICATED METAL DRAIN PAN CAN ALSO BE USED FOR APPLICATIONS WHERE TEMPERATURE EXCEEDS 300°F. FAILURE TO FOLLOW THIS WARNING MAY RESULT IN PROPERTY DAMAGE AND/OR PERSONAL INJURY.

If the uncased coil is to be installed on top of a gas furnace, allow enough space between the top to the furnace and the bottom of the plastic coil drain pan to have a free flow of air.

A minimum of 2.0" distance from the top of the furnace and the bottom of the coil pan is required.

**NOTE:** The coil must be installed with the line set and drain openings to the front of the furnace.

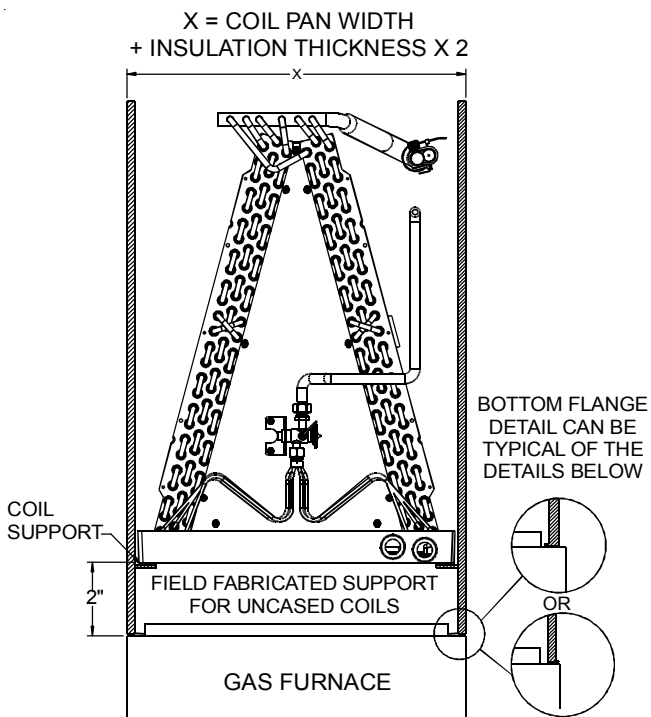

Figure 4

**NOTE:** Water coming from the secondary line means the coil primary drain is plugged and needs immediate attention.

Install a trap in the drain line below the bottom of the drain pan (Figure 5). If using a copper drain line, solder a short piece of pipe, minimum 6" length, to the connector before installing a drain fitting.

DO NOT over torque the 3/4" copper connector to the plastic drain connection. Using a wet rag or heatsink material on the short piece to protect the plastic drain pan, complete the drain line installation. Use Figure 6 as a template for typical drain pipe routing. This figure shows how to avoid interference with vent piping.

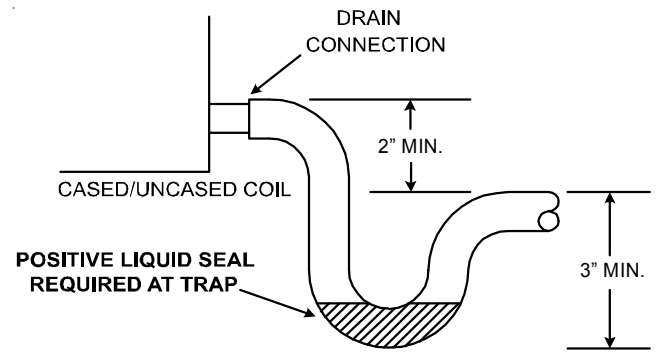

Figure 5

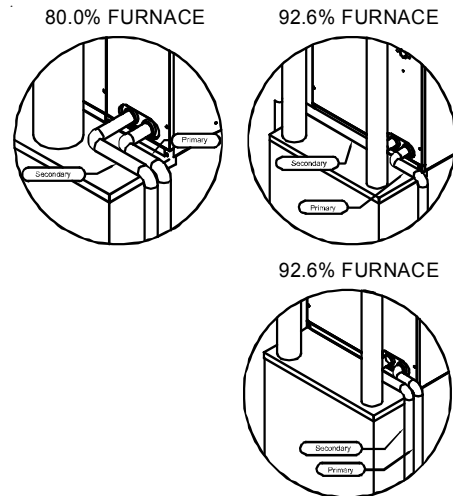

Figure 6

## 12. Return Ductwork

DO NOT TERMINATE THE RETURN DUCTWORK IN AN AREA THAT CAN INTRODUCE TOXIC OR OBJECTIONABLE FUMES/ODORS INTO THE DUCTWORK.

## 13. Sealing Along The Panel Gap

**IMPORTANT NOTE:** To prevent cabinet sweating and airflow leak, apply field provided insulation tape along all joining surfaces between the coil, gas furnace, duct work and panels. See Figure 7.

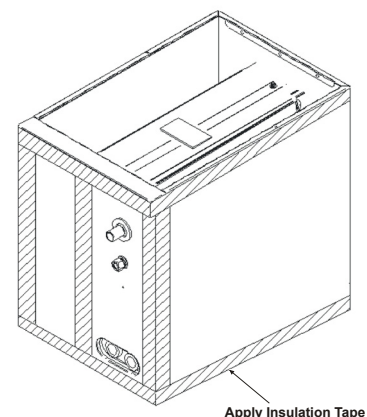

Figure 7

#### **14. Aluminum Indoor Coil Cleaning (Qualified Servicer Only)**

This unit is equipped with an aluminum tube evaporator coil. The safest way to clean the evaporator coil is to simply flush the coil with water. This cleaning practice remains as the recommended cleaning method for both copper tube and aluminum tube residential evaporator coils.

It has been determined that many coil cleaners and drain pan tablets contain corrosive chemicals that can be harmful to aluminum tube and fin evaporator coils. Even a one-time application of these corrosive chemicals can cause premature aluminum evaporator coil failure. Any cleaners that contain corrosive chemicals including, but not limited to, chlorine and hydroxides, should not be used.

An alternate cleaning method is to use one of the products listed in TP-109\* to clean the coils. The cleaners listed are the only agents deemed safe and approved for use to clean round tube aluminum coils. TP-109 is also available on the web site in Partner Link > Service Toolkit.

*NOTE: Ensure coils are rinsed well after use of any chemical cleaners.*

**THIS PAGE WAS LEFT BLANK INTENTIONALLY**

**THIS PAGE WAS LEFT BLANK INTENTIONALLY**

### CUSTOMER FEEDBACK

We are very interested in all product comments.

Please fill out the feedback form on one of the following links:

Goodman® Brand Products: (<http://www.goodmanmfg.com/about/contact-us>).

Amana® Brand Products: (<http://www.amana-hac.com/about-us/contact-us>).

You can also scan the QR code on the right for the product brand you purchased to be directed to the feedback page.



GOODMAN® BRAND



AMANA® BRAND

### PRODUCT REGISTRATION

Thank you for your recent purchase. Though not required to get the protection of the standard warranty, registering your product is a relatively short process, and entitles you to additional warranty protection, except that failure by California and Quebec residents to register their product does not diminish their warranty rights.

For Product Registration, please register as follows:

Goodman® Brand products: (<https://www.goodmanmfg.com/product-registration>).

Amana® Brand products: (<http://www.amana-hac.com/product-registration>)

You can also scan the QR code on the right for the product brand you purchased to be directed to the Product Registration page.



GOODMAN® BRAND



AMANA® BRAND

NOTE: SPECIFICATIONS AND PERFORMANCE DATA LISTED HEREIN ARE SUBJECT TO CHANGE WITHOUT NOTICE

Visit our websites at [www.goodmanmfg.com](http://www.goodmanmfg.com) or [amana-hac.com](http://amana-hac.com) for information on:

- Products
- Warranties
- Customer Services
- Parts
- Contractor Programs and Training
- Financing Options

5151 San Felipe, Suite 500, Houston, TX 77056

© 2005-2006, 2012-2013, 2015-2018 Goodman Manufacturing Company, L.P.

**Amana** is a registered trademark of Maytag Corporation or its related companies and is used under license. All rights reserved.