

WALL MOUNT AIR HANDLERS

INSTALLATION INSTRUCTIONS & OPERATING INSTRUCTIONS

© 2023 **DAIKIN COMFORT TECHNOLOGIES MANUFACTURING, L.P.**
19001 Kermier Rd., Waller, TX 77484
www.daikinac.com
P/N: IO-4010 Date: December 2023

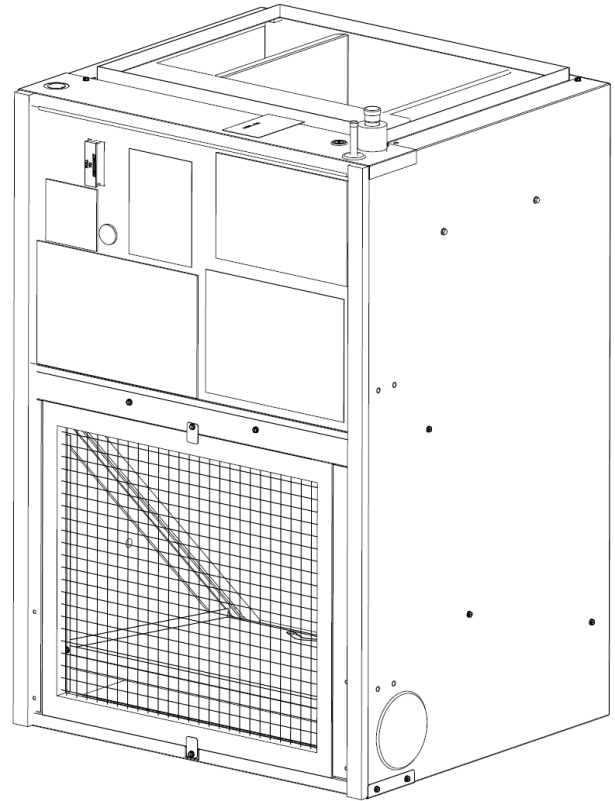
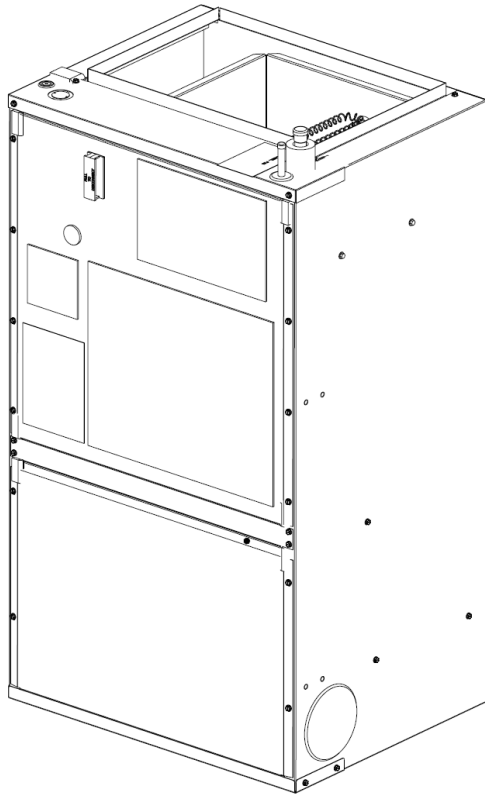

AWSF/AWST 18-24



WARNING

ONLY PERSONNEL THAT HAVE BEEN TRAINED TO INSTALL, ADJUST, SERVICE, MAINTENANCE OR REPAIR (HEREINAFTER, "SERVICE") THE EQUIPMENT SPECIFIED IN THIS MANUAL SHOULD SERVICE THE EQUIPMENT. THE MANUFACTURER WILL NOT BE RESPONSIBLE FOR ANY INJURY OR PROPERTY DAMAGE ARISING FROM IMPROPER SERVICE OR SERVICE PROCEDURES. IF YOU SERVICE THIS UNIT, YOU ASSUME RESPONSIBILITY FOR ANY INJURY OR PROPERTY DAMAGE WHICH MAY RESULT. IN ADDITION, IN JURISDICTIONS THAT REQUIRE ONE OR MORE LICENSES TO SERVICE THE EQUIPMENT SPECIFIED IN THIS MANUAL, ONLY LICENSED PERSONNEL SHOULD SERVICE THE EQUIPMENT. IMPROPER INSTALLATION, ADJUSTMENT, SERVICING, MAINTENANCE OR REPAIR OF THE EQUIPMENT SPECIFIED IN THIS MANUAL, OR ATTEMPTING TO INSTALL, ADJUST, SERVICE OR REPAIR THE EQUIPMENT SPECIFIED IN THIS MANUAL WITHOUT PROPER TRAINING MAY RESULT IN PRODUCT DAMAGE, PROPERTY DAMAGE, PERSONAL INJURY OR DEATH.

AWSF/AWST 30-36



WARNING

DO NOT BYPASS SAFETY DEVICES



RECOGNIZE THIS SYMBOL AS A SAFETY PRECAUTION.

NOTE: SPECIFICATIONS AND PERFORMANCE DATA LISTED HEREIN ARE SUBJECT TO CHANGE WITHOUT NOTICE.

NOTE: NEVER OPERATE THE UNIT WITHOUT THE RECOMMENDED FILTER OR THE OUTER PANEL INSTALLED.

NOTE: THIS EQUIPMENT IS APPROVED TO USE ONLY WITH R-32 REFRIGERANT



CONTENTS

1 Important Safety Instructions	3
2 Codes & Regulations	3
3 Clearances	3
4 Wiring Diagrams	5
5 Air Flow Data & Wiring Diagrams	9
5.1 Low Voltage Connections	10
6 Electrical And Control Wiring	10
6.1 Building Electrical Service Inspection.....	10
6.2 Wire Sizing	10
6.3 Maximum Overcurrent Protection (MOP)	11
6.4 Electrical Connections – Supply Voltage	11
6.5 Fresh Air Openings.....	11
6.6 Wiring	11
7 Heater Kit Service	11
8 Charging Procedure	12
8.1 Annex GG-Mitigation Mode Table.....	12
9 Shipping Inspection	14
9.1 Parts	14
9.2 Handling	14
9.3 Shipping Material Removal.....	14
10 Replacement Parts	14
11 Pre-Installation Instructions	14
11.1 Preparation	14
11.2 System Matches	14
11.3 Interconnecting Tubing	14
12 Application Information	14
13 Achieving Low Air Leakage Rate	15
14 Start-Up Procedure	15
15 Refrigeration Detection System (RSD)	15
15.1 Detection of Refrigerant.....	15
15.2 Removal and Evacuation.....	15
15.3 Refrigerant Recovery.....	16
15.4 R-32 Sensor Servicing Instructions	16
15.4.1 Sensor Dismounting Instructions.....	16
15.4.2 Sensor Mounting Instructions	16
15.5 A2L PCB Servicing Instructions.....	17
16 AWST-Factory Installed TXV Models	20
16.1 Tubing Size.....	20
16.2 Tubing Connections	20
16.3 Thermal Expansion Valve System Adjustment	20
17 AWSF Fixed Orifice Adjustment	21
18 Expansion Valve Troubleshooting	21
19 Maintenance	21
20 Start-Up Checklist	23

 **WARNING**

A REFRIGERANT LEAK DETECTION SYSTEM IS INSTALLED. THE UNIT MUST BE POWERED ON AT ALL TIMES EXCEPT FOR SERVICE.

 **WARNING**

HIGH VOLTAGE
DISCONNECT ALL POWER BEFORE SERVICING OR INSTALLING THIS UNIT. MULTIPLE POWER SOURCES MAY BE PRESENT. FAILURE TO DO SO MAY CAUSE PROPERTY DAMAGE, PERSONAL INJURY OR DEATH.



 **WARNING**

TO PREVENT THE RISK OF PROPERTY DAMAGE, PERSONAL INJURY, OR DEATH, DO NOT STORE COMBUSTIBLE MATERIALS OR USE GASOLINE OR OTHER FLAMABLE LIQUIDS OR VAPORS IN THE VICINITY OF THIS APPLIANCE.

 **CAUTION**

HAVE YOUR CONTRACTOR IDENTIFY ALL THE VARIOUS CUT OFF SWITCHES AND DEVICES THAT SERVICE THIS UNIT. KNOW WHERE THE SWITCH IS THAT WILL CUT OFF ENERGY TO THE HEATING SYSTEM IN THE EVENT OF OVERHEATING.

 **CAUTION**

THIS APPLIANCE IS NOT INTENDED FOR THE USE BY PERSONS (INCLUDING CHILDREN) WITH THE REDUCED PHYSICAL, SENSORY OR MENTAL CAPABILITIES, OR LACK OF EXPERIENCE AND KNOWLEDGE, UNLESS THEY HAVE BEEN GIVEN SUPERVISION OR INSTRUCTION CONCERNING USE OF THE APPLIANCE BY A PERSON RESPONSIBLE FOR THEIR SAFETY. CHILDREN SHOULD BE SUPERVISED TO ENSURE THAT THEY DO NOT PLAY WITH THE APPLIANCE. APPLIANCE NOT ACCESSIBLE TO THE GENERAL PUBLIC.

 **WARNING**

THIS UNIT SHOULD NOT BE CONNECTED TO, OR USED IN CONJUNCTION WITH, ANY DEVICES THAT ARE NOT DESIGN CERTIFIED FOR USE WITH THIS UNIT OR HAVE NOT BEEN TESTED AND APPROVED BY THE MANUFACTURER. SERIOUS PROPERTY DAMAGE OR PERSONAL INJURY, REDUCED UNIT PERFORMANCE AND/OR HAZARDOUS CONDITIONS MAY RESULT FROM THE USE OF DEVICES THAT HAVE NOT BEEN APPROVED OR CERTIFIED BY THE MANUFACTURER.

 **WARNING**

PARTIAL UNITS SHALL ONLY BE CONNECTED TO AN APPLIANCE SUITABLE FOR THE SAME REFRIGERANT. THIS UNIT IS A PARTIAL UNIT AIR CONDITIONER, COMPLYING WITH PARTIAL UNIT REQUIREMENTS OF THIS INTERNATIONAL STANDARD, AND MUST ONLY BE CONNECTED TO OTHER UNITS THAT HAVE BEEN CONFIRMED AS COMPLYING TO CORRESPONDING PARTIAL UNIT REQUIREMENTS OF THIS INTERNATIONAL STANDARD.

 **WARNING**

DO NOT USE MEANS TO ACCELERATE THE DEFROSTING PROCESS OR TO CLEAN, OTHER THAN THOSE RECOMMENDED BY THE MANUFACTURER. THE APPLIANCE SHALL BE STORED IN A ROOM WITHOUT CONTINUOUSLY OPERATING IGNITION SOURCES (FOR EXAMPLE: OPEN FLAMES, AN OPERATING GAS APPLIANCE OR AN OPERATING ELECTRIC HEATER. DO NOT PIERCE OR BURN. BE AWARE THAT REFRIGERANTS MAY NOT CONTAIN AN ODOR.



DANGER
PELIGRO

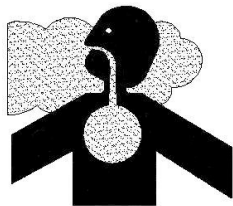

CARBON MONOXIDE POISONING HAZARD

Special Warning for Installation of Furnace or Air Handling Units in Enclosed Areas such as Garages, Utility Rooms or Parking Areas

Carbon monoxide producing devices (such as automobiles, space heater, gas water heater, etc.) should not be operated in enclosed areas such as unventilated garages, utility rooms or parking areas because of the danger of carbon monoxide (CO) poisoning resulting from the exhaust emissions. If a furnace or air handler is installed in an enclosed area such as a garage, utility room or parking area and a carbon monoxide producing device is operated therein, there must be adequate, direct outside ventilation.

This ventilation is necessary to avoid the danger of CO poisoning which can occur if a carbon monoxide producing device continues to operate in the enclosed area. Carbon monoxide emissions can be (re)circulated throughout the structure if the furnace or air handler is operating in any mode.

CO can cause serious illness including permanent brain damage or death.

B10259-216

RIESGO DE INTOXICACIÓN POR MONÓXIDO DE CARBONO

Advertencia especial para la instalación de calentadores ó manejadoras de aire en áreas cerradas como estacionamientos ó cuartos de servicio.

Los equipos ó aparatos que producen monóxido de carbono (tal como automóvil, calentador de gas, calentador de agua por medio de gas, etc) no deben ser operados en áreas cerradas debido al riesgo de envenenamiento por monóxido de carbono (CO) que resulta de las emisiones de gases de combustión. Si el equipo ó aparato se opera en dichas áreas, debe existir una adecuada ventilación directa al exterior.

Esta ventilación es necesaria para evitar el peligro de envenenamiento por CO, que puede ocurrir si un dispositivo que produce monóxido de carbono sigue operando en el lugar cerrado.

Las emisiones de monóxido de carbono pueden circular a través del aparato cuando se opera en cualquier modo.

El monóxido de carbono puede causar enfermedades severas como daño cerebral permanente ó muerte.

B10259-216

RISQUE D'EMPOISONNEMENT AU MONOXYDE DE CARBONE

Avertissement special au sujet de l'installation d'appareils de chauffage ou de traitement d'air dans des endroits clos, tels les garages, les locaux d'entretien et les stationnements.

Evitez de mettre en marche les appareils produisant du monoxyde de carbone (tels que les automobile, les appareils de chauffage autonome, etc.) dans des endroits non ventilés tels que les d'empoisonnement au monoxyde de carbone. Si vous devez faire fonctionner ces appareils dans un endroit clos, assurez-vous qu'il y ait une ventilation directe provenant de l'exterieur.

Cette ventilation est nécessaire pour éviter le danger d'intoxication au CO pouvant survenir si un appareil produisant du monoxyde de carbone continue de fonctionner au sein de la zone confinée.

Les émissions de monoxyde de carbone peuvent etre recircules dans les endroits clos, si l'appareil de chauffage ou de traitement d'air sont en marche.

Le monoxyde de carbone peut causer des maladies graves telles que des dommages permanents au cerveau et meme la mort.

B10259-216



WARNING

AUXILIARY DEVICES WHICH MAY BE A POTENTIAL IGNITION SOURCE SHALL NOT BE INSTALLED IN THE DUCT WORK. EXAMPLES OF SUCH POTENTIAL IGNITION SOURCES ARE HOT SURFACES WITH A TEMPERATURE EXCEEDING 700 °C AND ELECTRIC SWITCHING DEVICES.

1 IMPORTANT SAFETY INSTRUCTIONS

The following symbols and labels are used throughout this manual to indicate immediate or potential safety hazards. It is the owner's and installer's responsibility to read and comply with all safety information and instructions accompanying these symbols. Failure to heed safety information increases the risk of personal injury, property damage, and/or product damage.

2 CODES & REGULATIONS

This product is designed and manufactured to comply with national codes such as ASHRAE 15, ASHRAE 15.2, IAPMO Uniform Mechanical Code, ICC International Mechanical Code, or CSA B52. Installation in accordance with such codes and/or prevailing local codes/regulations is the responsibility of the installer. The manufacturer assumes no responsibility for equipment installed in violation of any codes or regulations.

The standard test ambient operating conditions for cooling and heating mode are 80°F and 70°F, respectively.

The United States Environmental Protection Agency (EPA) has issued various regulations regarding the introduction and disposal of refrigerants. Failure to follow these regulations may harm the environment and can lead to the imposition of substantial fines. These regulations may vary by jurisdiction. A certified technician must perform the installation and service of this product. Should you have any questions please contact the local office of the EPA and/or refer to the EPA's website www.epa.gov.

3 CLEARANCES



WARNING

WHEN INSTALLED IN A ROOM WITH AN AREA LESS THAN THAT OUTLINED IN TABLE 5, THAT ROOM SHALL BE WITHOUT CONTINUOUSLY OPERATING OPEN FLAMES (FOR EXAMPLE AN OPERATING GAS APPLIANCE) OR OTHER POTENTIAL IGNITION SOURCES (FOR EXAMPLE AN OPERATING ELECTRIC HEATER, HOT SURFACES). A FLAME-PRODUCING DEVICE MAY BE INSTALLED IN THE SAME SPACE IF THE DEVICE IS PROVIDED WITH AN EFFECTIVE FLAME ARREST.



WARNING

AUXILIARY DEVICES WHICH MAY BE A POTENTIAL IGNITION SOURCE ARE NOT TO BE INSTALLED IN THE DUCT WORK. SUCH POTENTIAL IGNITION SOURCES INCLUDE HOT SURFACES WITH A TEMPERATURE EXCEEDING 700°C AND ELECTRIC SWITCHING DEVICES.



WARNING

THE ONLY AUXILIARY DEVICES APPROVED BY THE APPLIANCE MANUFACTURER OR DECLARED SUITABLE WITH THE REFRIGERANT SHALL BE INSTALLED IN CONNECTING DUCTWORK.

The unit clearance from a combustible surface may be 0". However, service clearance must take precedence. A minimum of 24" in front of the unit for service clearance is required. Additional clearance on one side or top will be required for electrical wiring connections. Consult all appropriate regulatory codes prior to determining final clearances. When installing this unit in an area that may become wet (such as crawl spaces), elevate the unit with a sturdy, non-porous material. In installations that may lead to physical damage (i.e. a garage) it is advised to install a protective barrier to prevent such damage. Always install units such that a positive slope in condensate line (1/4" per foot) is allowed. Further, any joints made in the installation between parts of the refrigerating system must be accessible for maintenance purposes.

WARNING

HIGH VOLTAGE!
DISCONNECT ALL POWER BEFORE SERVICING OR INSTALLING THIS UNIT.
MULTIPLE POWER SOURCES MAY BE PRESENT. FAILURE TO DO SO MAY
CAUSE PROPERTY DAMAGE, PERSONAL INJURY OR DEATH.

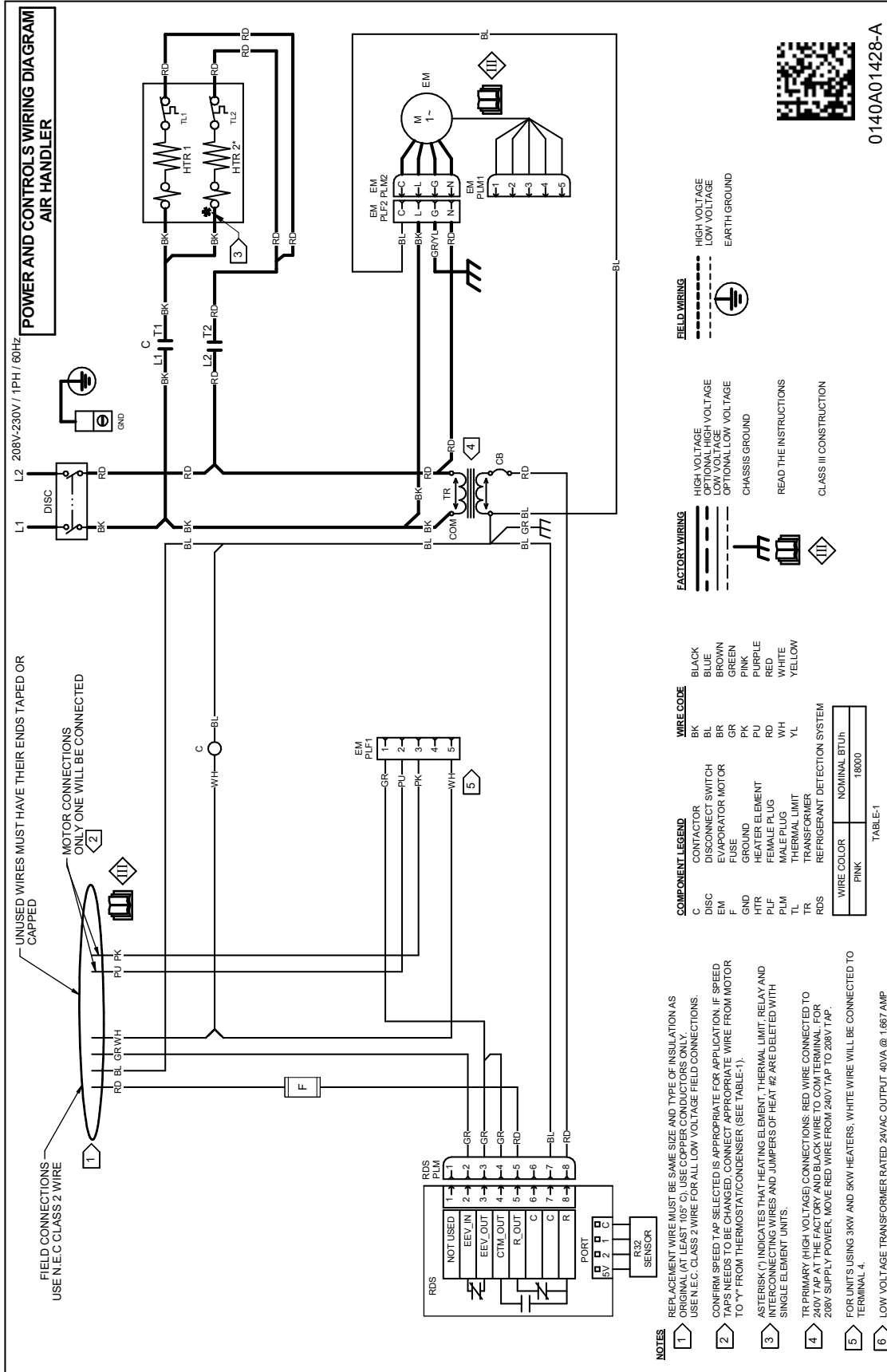

Wiring is subject to change. Always refer to the Wiring Diagram on the unit for the most up-to-date wiring.

WARNING

HIGH VOLTAGE!

DISCONNECT ALL POWER BEFORE SERVICING OR INSTALLING THIS UNIT.
MULTIPLE POWER SOURCES MAY BE PRESENT. FAILURE TO DO SO MAY
CAUSE PROPERTY DAMAGE, PERSONAL INJURY OR DEATH.

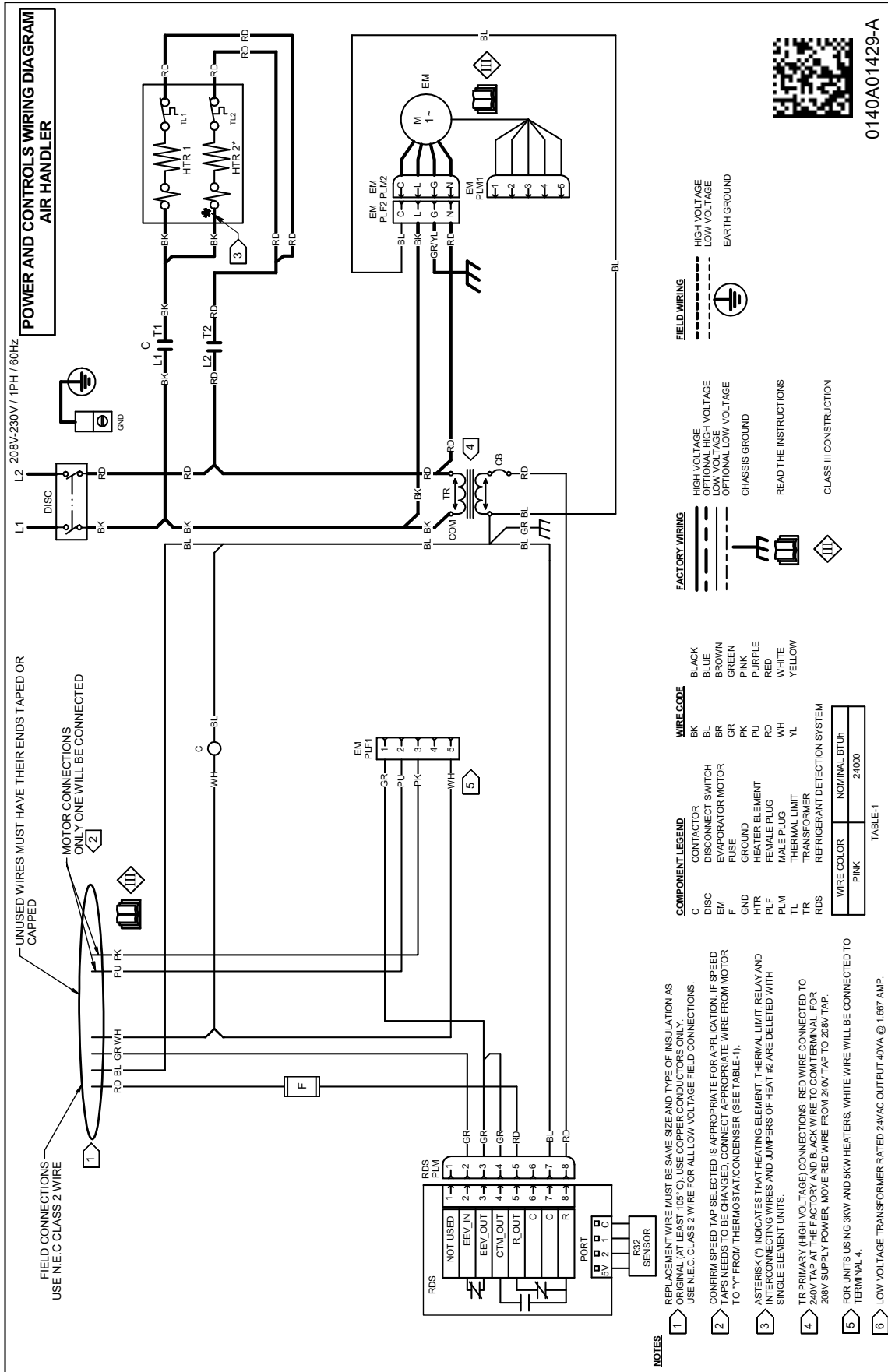

Wiring is subject to change. Always refer to the Wiring Diagram on the unit for the most up-to-date wiring.

WARNING

HIGH VOLTAGE!

DISCONNECT ALL POWER BEFORE SERVICING OR INSTALLING THIS UNIT.
MULTIPLE POWER SOURCES MAY BE PRESENT. FAILURE TO DO SO MAY
CAUSE PROPERTY DAMAGE, PERSONAL INJURY OR DEATH.

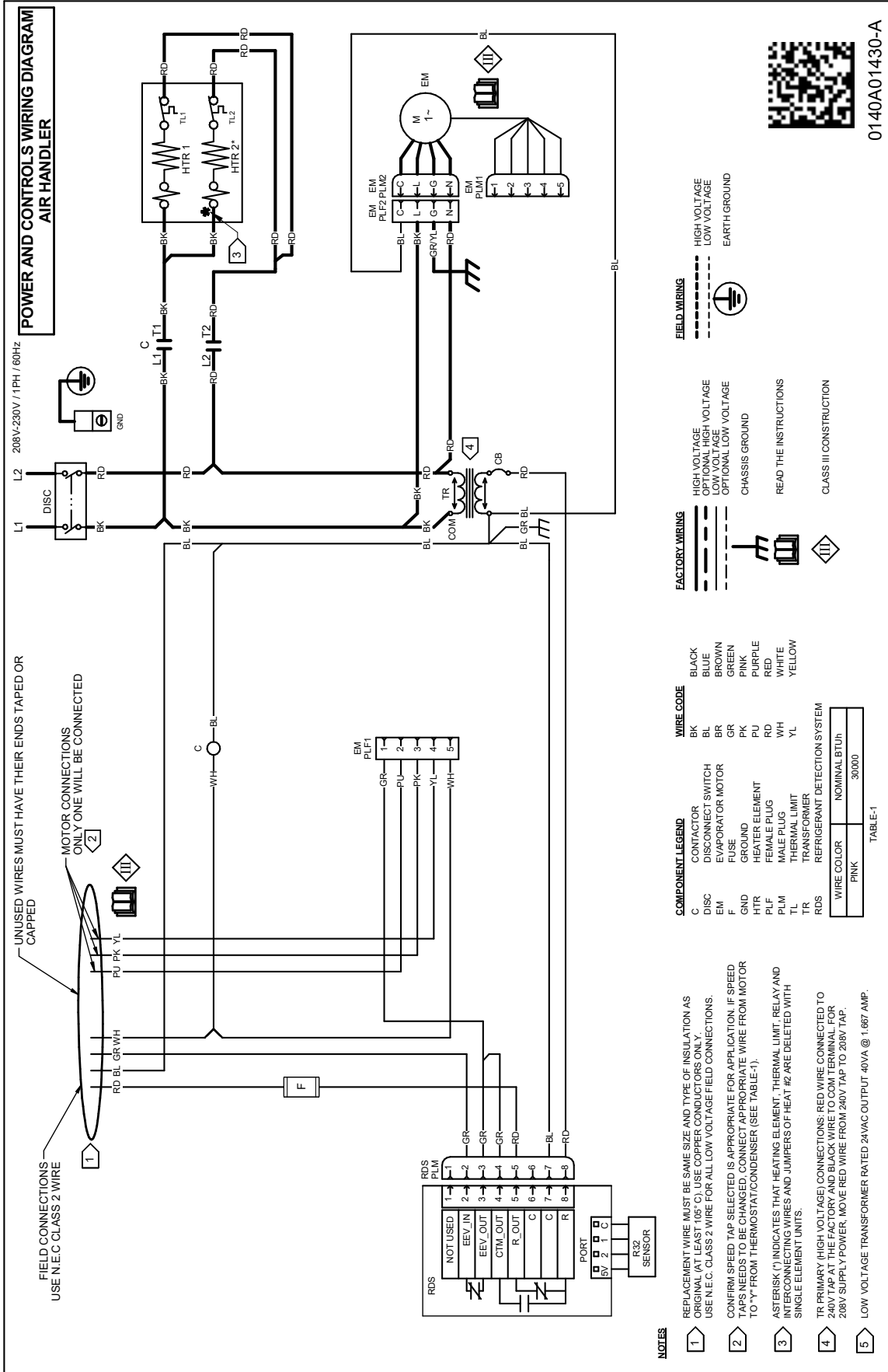

Wiring is subject to change. Always refer to the Wiring Diagram on the unit for the most up-to-date wiring.

WARNING

HIGH VOLTAGE!

DISCONNECT ALL POWER BEFORE SERVICING OR INSTALLING THIS UNIT.
MULTIPLE POWER SOURCES MAY BE PRESENT. FAILURE TO DO SO MAY
CAUSE PROPERTY DAMAGE, PERSONAL INJURY OR DEATH.

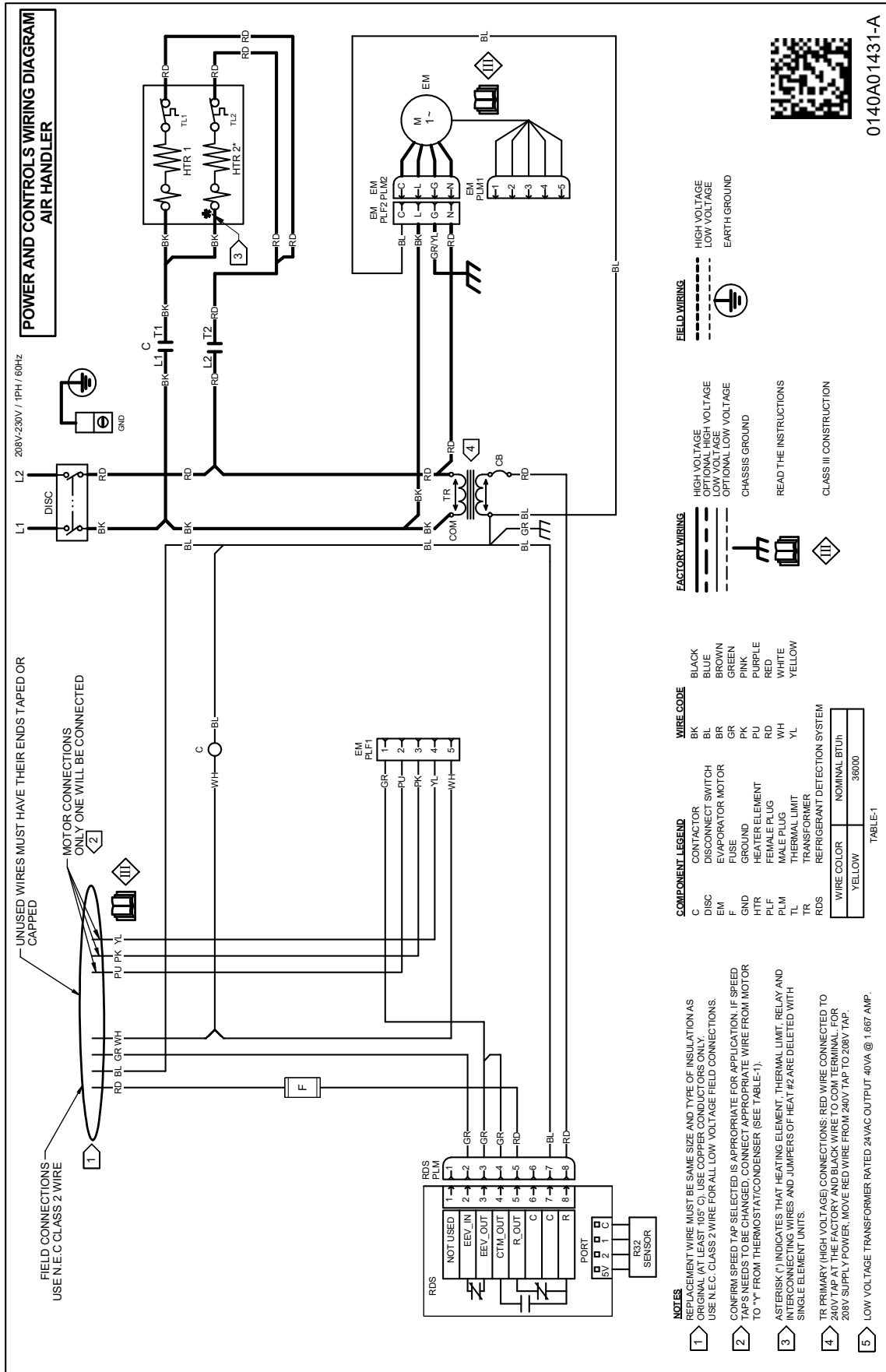

Wiring is subject to change. Always refer to the Wiring Diagram on the unit for the most up-to-date wiring.

5 AIR FLOW DATA & WIRING DIAGRAMS

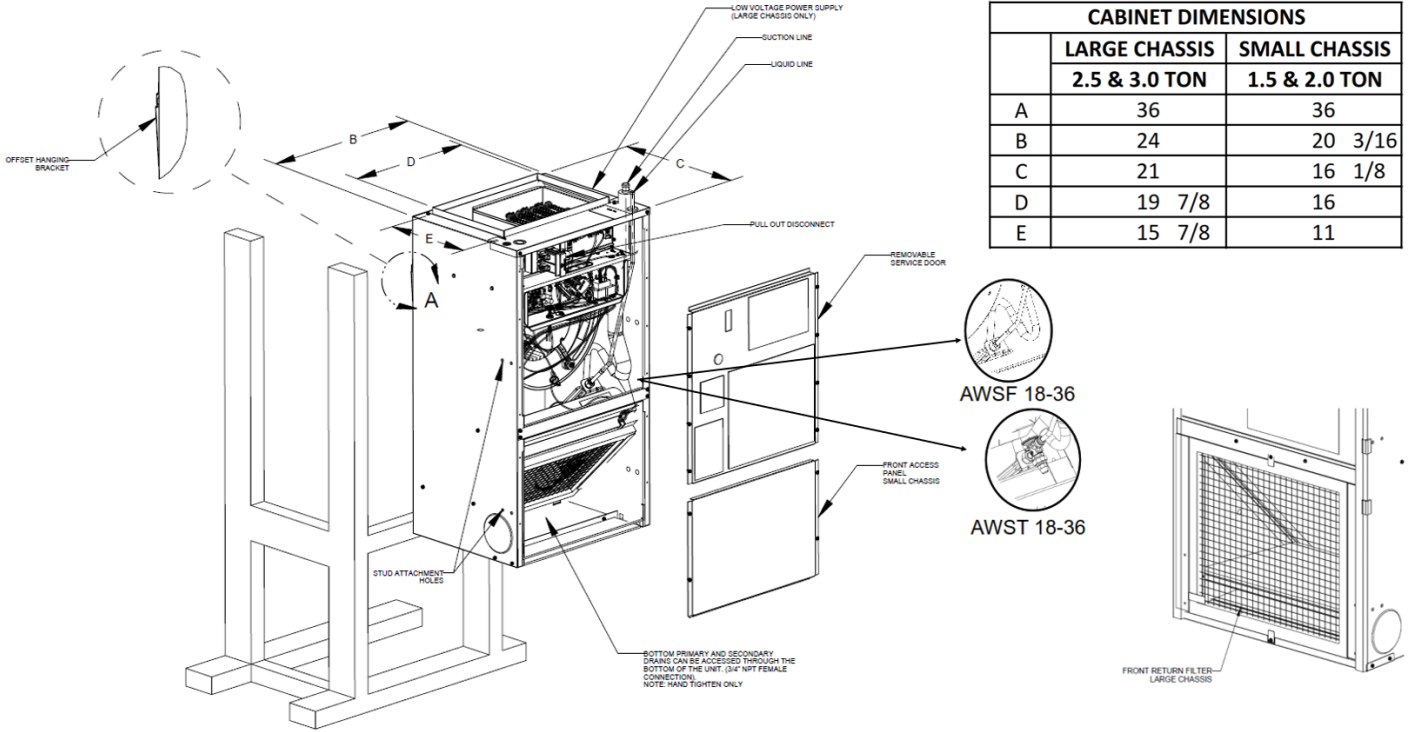

CABINET DIMENSIONS		
	LARGE CHASSIS	SMALL CHASSIS
	2.5 & 3.0 TON	1.5 & 2.0 TON
A	36	36
B	24	20 3/16
C	21	16 1/8
D	19 7/8	16
E	15 7/8	11

Figure 1

NOTE: SPECIFICATIONS & PERFORMANCE DATA LISTED HEREIN ARE SUBJECT TO CHANGE WITHOUT NOTICE.

AWSF/AWST 18, 24, 30, 36

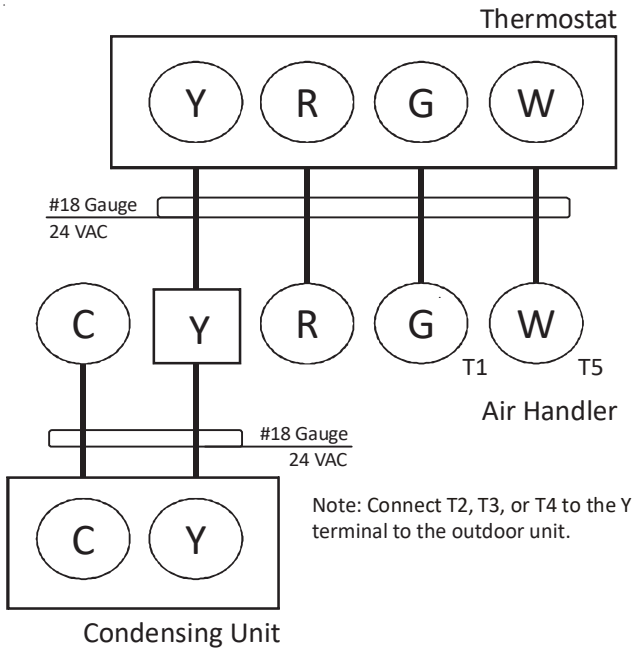

Figure 2

Model	TAP	COLOR
AWSF18SU13**	T1	GREEN
AWST18SU13**	T2	PURPLE
AWSF24SU13**	T3	PINK
AWST24SU13**	T4	*
	T5	WHITE

Table 1

*NOTE: For units using 3KW and 5KW heaters, White wire will be connected to terminal 4.

Model	TAP	COLOR
AWSF30LU13**	T1	GREEN
AWST30LU13**	T2	PURPLE
AWSF36LU13**	T3	PINK
AWST36LU13**	T4	YELLOW
	T5	WHITE

Table 2

NOTE: Connect appropriate speed tap (Pink/Purple/Yellow) to Y. Refer to Table 1 & 2 for speed tap selection.

5.1 LOW VOLTAGE CONNECTIONS

Several combinations of low voltage schemes are possible, depending on the presence of a heat kit and whether the heat kit is single-stage or multi-stage, whether the outdoor section is an air conditioner or heat pump, and whether the outdoor section is single-stage or two stage. The 24V-control voltage connects the air handle to the room thermostat and condenser. Low voltage wiring must be copper conductors. A minimum of 18AWG must be used for installations. Low voltage wiring must be connected through the top of the cabinet or either side.

Model	Speed Tap	CFM @ STATIC PRESSURE (IN W.C.)		
		0.1	0.2	0.3
AWSF18SU13** AA AWST18SU13** AA	T1	630	602	576
	T2	630	602	576
	T3	637	609	586
	T4	630	602	576
	T5	846	824	800
AWSF24SU13** AA AWST24SU13** AA	T1	630	602	576
	T2	630	602	576
	T3	784	763	742
	T4	630	602	576
	T5	846	823	800
AWSF30LU13** AA AWST30LU13** AA	T1	722	674	623
	T2	945	907	864
	T3	1111	1079	1040
	T4	975	935	896
	T5	1209	1175	1139
AWSF36LU13** AA AWST36LU13** AA	T1	1114	1072	1031
	T2	1114	1072	1031
	T3	1225	1191	1152
	T4	1287	1255	1219
	T5	1360	1329	1299

Table 3

NOTE:

1. Airflow data indicated is at 230V without air filter in place.
2. Select a speed tap that provides a minimum 300 CFM per outdoor ton. For satisfactory operation, external static pressure must no exceed 0.3" WC (for electric heater only).
3. Speed Tap T1 is used for both fan only mode and mitigation and not to be used for any other mode.
4. Airflow test data is proved to satisfy minimum room area (A_{min}) and minimum airflow at mitigation mode (Q_{min}). See Table 5.

6 ELECTRICAL AND CONTROL WIRING

IMPORTANT: The appliance shall be installed in accordance with national wiring regulations. All routing of electrical wiring must be made through provided electrical knockouts. Do not cut, puncture or alter the cabinet for electrical wiring.

WARNING

HIGH VOLTAGE
TO AVOID THE RISK OF FIRE OR EQUIPMENT DAMAGE, USE ONLY COPPER CONDUCTORS. DISCONNECT ALL POWER BEFORE SERVICING OR INSTALLING THIS UNIT. MULTIPLE POWER SOURCES MAYBE PRESENT. THE ELECTRICAL POWER TO THIS UNIT MUST BE IN THE OFF POSITION AND ALL POWER SUPPLIES DISCONNECTED.
FAILURE TO DO SO MAY CAUSE PROPERTY DAMAGE, PERSONAL INJURY OR DEATH.



WARNING

THE UNIT MUST HAVE AN UNINTERRUPTED, UNBROKEN ELECTRICAL GROUND TO MINIMIZE THE POSSIBILITY OF PERSONAL INJURY IF AN ELECTRICAL FAULT SHOULD OCCUR. THE ELECTRICAL GROUND CIRCUIT MAY CONSIST OF AN APPROPRIATELY SIZED ELECTRICAL WIRE CONNECTING THE GROUND LUG IN THE UNIT AND CONTROL BOX WIRE TO THE BUILDING'S ELECTRICAL SERVICE PANEL. OTHER METHODS OF GROUNDING ARE PERMITTED IF PERFORMED IN ACCORDANCE WITH THE "NATIONAL ELECTRIC CODE" (NEC)/"AMERICAN NATIONAL STANDARDS INSTITUTE" (ANSI)/"NATIONAL FIRE PROTECTION ASSOCIATION" (NFPA) 70 AND LOCAL/STATE CODES. IN CANADA, ELECTRICAL GROUNDING IS TO BE IN ACCORDANCE WITH THE CANADIAN ELECTRIC CODE CSA C22.1. FAILURE TO OBSERVE THIS WARNING CAN RESULT IN ELECTRICAL SHOCK THAT CAN CAUSE PERSONAL INJURY OR DEATH.

6.1 BUILDING ELECTRICAL SERVICE INSPECTION

This unit is designed for single-phase electrical supply.

NOTE: DO NOT OPERATE ON A THREE-PHASE POWER SUPPLY.

Measure the power supply to the unit. The supply voltage must be in agreement with the unit name plate power requirements and within the range shown in Table 4.

Nominal Input	Minimum Voltage	Maximum Voltage
208/230	187	253

ELECTRICAL VOLTAGE
Table 4

6.2 WIRE SIZING

Wire size is important to the operation of your equipment. Use the following checklist when selecting the appropriate wire size for the unit.

- Wire used must carry the Minimum circuit Ampacity (MCA) listed on the unit's Series and Rating Plate.
- Refer to the NEC (USA) or CSA (Canada) for wire sizing. The unit MCA for the air handler and the optional electric heat kit can be found on the unit Series and Rating Plate.
- Wire must be sized to allow no more than a 2% voltage

drop from the building breaker/fuse panel to the unit.

- Wires with different insulation temperature rating have varying ampacities - be sure to check the temperature rating used.

Refer to the latest edition of the National Electric Code or in Canada the Canadian Electric Code when determining the correct wire size.

6.3 MAXIMUM OVERCURRENT PROTECTION (MOP)

Every installation must include an NEC (USA) or CEC (Canada) approved overcurrent protection device. Also, check with local or state codes for any special regional requirements.

Protection can be in the form of fusing or HACR style circuit breakers. The Series and Rating Plate can be used as a guide for selecting the MAXIMUM overcurrent device.

NOTE: Fuses or circuit breakers are to be sized larger than the equipment MCA but not to exceed the MOP.

IMPORTANT NOTE: Torch heat required to braze tubes of various sizes is proportional to the size of the tube. Tubes of smaller size require less heat to bring the tube to brazing temperature before adding brazing alloy. Applying too much heat to any tube can melt the tube. Service personnel must use the appropriate heat level for the size of the tube being brazed.

NOTE: The use of a heat shield when brazing is recommended to avoid burning the serial plate or the finish on the unit. Heat trap or wet rags should be used to protect heat sensitive components such as service valves and TXV valves.

6.4 ELECTRICAL CONNECTIONS – SUPPLY VOLTAGE

 CAUTION
FIRE HAZARD! TO AVOID THE RISK OF PROPERTY DAMAGE, PERSONAL INJURY OR FIRE, USE ONLY COPPER CONDUCTORS.

IMPORTANT NOTE: Use copper conductors only from disconnect or electrical panel to the air handler.

A knockout is provided on the air handler top panel or side to allow for the entry of the supply voltage conductors. If the knockouts on the cabinet sides are used for electrical conduit, an adapter ring must be used in order to meet safety requirements. An NEC or CEC approved strain relief is to be used at this entry point. The wire is to be sized in accordance with the “Electrical Wire and MOP” section of this manual. Some areas require the supply wire to be enclosed in conduit. Consult your local codes.

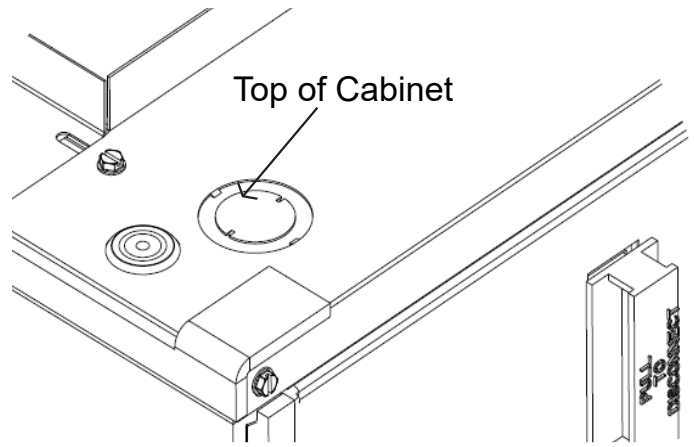

Knock-out for Electrical Connections
Figure 3

6.5 FRESH AIR OPENINGS

All AWSF/AWST models include 4” fresh air knockouts on both sides of the cabinet. To utilize, simply remove the appropriate knockout and connect fresh air inlet venting directly to cabinet. Ensure the unit mounting system does not block the fresh air inlet holes.

6.6 WIRING

Check that cabling will not be subject to wear, corrosion, excessive pressure, vibration, sharp edges or any other adverse environmental effects. The check shall also take into account the effects of aging or continual vibration from sources such as compressors or fans.

NOTE: The installing contractor must take into account any lost capacity due to the the fresh air openings when sizing the equipment.

7 HEATER KIT SERVICE

This comfort equipment comes pre-installed with a UL 2-40 certified heater kit. In times of replacement, please ensure that only a UL 2-40 certified kit is utilized.

Refer to the air handler unit's Serial plate to determine the heat kits compatible with a given air handler.

For removing a pre-installed heater kit:

1. Remove the disconnect switch from the air handler to turn off the unit.
2. Remove the upper access panel.
3. Remove the red and black wire from the heater kit.
4. Remove and retain the four (4) screws securing the heater kit.
5. Slide the heater kit out of the unit.

For Installing a new heater kit:

6. Slide the electric heat kit into the opening in the air handler, making sure the direction of airflow decal attached to the electric heat face plate is pointing in the correct direction.
7. Secure the electric heat face plate using the screws removed in Step 4. Use caution to not bend or damage the electric heating elements, the limit switches or fuses during this process. See below Figures 4 and 5

8. Attached the red and black wire to the heater kit removed in Step 3.
9. Install the upper access panel removed in Step 2.
10. Install the disconnect switch back to the air handler to turn on the unit.

8 CHARGING PROCEDURE

In addition to conventional charging procedures, the following requirements shall be followed:

- Ensure that contamination of different refrigerants does not occur when using charging equipment. Hoses or lines shall be as short as possible to minimise the amount of refrigerant contained in them.
- R-32 Cylinders shall be kept in an appropriate position according to the instructions.
- Ensure that the REFRIGERATING SYSTEM is earthed prior to charging the system with refrigerant.
- Label the system when charging is complete (if not already).
- Extreme care shall be taken not to overfill the REFRIGERATING SYSTEM.

Prior to recharging the system, it shall be pressure-tested with the appropriate purging gas. The system shall be leak-tested on completion of charging but prior to commissioning. A follow up leak test shall be carried out prior to leaving the site.

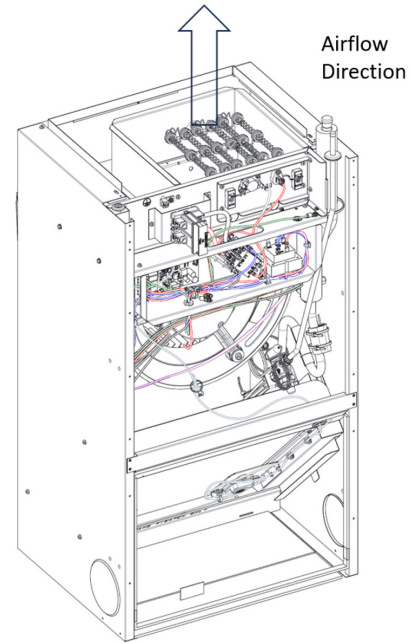

Figure 4

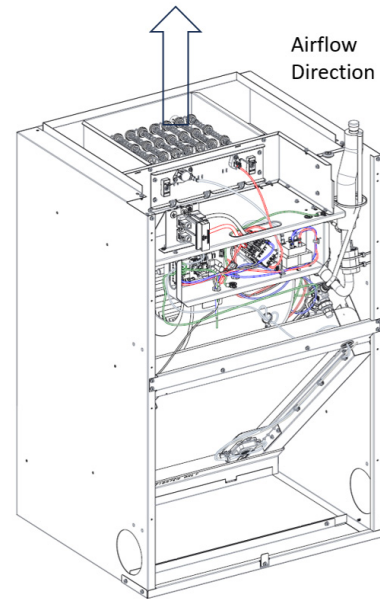

Figure 5

8.1 Annex GG – Mitigation Mode Table

Model	Q_{min} CFM Requirement	Speed Tap T1 CFM at 0.3 Static Pressure (in W.C.)	Minimum Room Area Requirement ($TA_{min} - m^2$)	Minimum Room Area Requirement ($TA_{min} - ft^2$)
AWSF18SU13** AA AWST18SU13** AA	361	576	18.58	200.00
AWSF24SU13** AA AWST24SU13** AA	361	576	18.58	200.00
AWSF30LU13** AA AWST30LU13** AA	406	525	20.90	225.00
AWSF36LU13** AA AWST36LU13** AA	406	1031	20.90	225.00

Q_{min} is the minimum circulation airflow circulated to the total conditioned space.

TA_{min} is the required minimum area of the total conditioned space.

Table 5

SATURATED SUCTION PRESSURE- TEMPERATURE CHART FOR R-32	
SUCTION PRESSURE (PSIG)	SATURATED SUCTION TEMPERATURE (°F)
50	1
52	2
54	4
56	5
58	6
60	8
62	9
64	10
66	12
68	13
70	14
72	15
74	17
76	18
78	19
80	20
82	21
84	22
86	23
88	24
90	25
92	26
94	27
96	28
98	29
100	30
102	31
104	32
106	33
108	34
110	35
120	40
130	44
140	48
150	52
160	55
170	59

Table 6

SATURATED LIQUID PRESSURE- TEMPERATURE CHART FOR R-32	
SUCTION PRESSURE (PSIG)	SATURATED SUCTION TEMPERATURE (°F)
200	68
210	71
220	74
230	77
240	80
250	82
260	85
270	87
280	90
290	92
300	94
320	99
340	103
360	107
380	111
400	115
420	118
440	122
460	125
480	128
500	132
520	135
540	138
560	141
580	143
600	146
620	149

Table 7

NOTE: Specifications and Performance Data listed herein are subject to change without notice.

9 SHIPPING INSPECTION

Upon receiving the product, inspect it for damage from shipment. Shipping damage, and subsequent investigation is the responsibility of the carrier. Verify the model number, specifications, electrical characteristics, and accessories are correct prior to installation. The distributor or manufacturer will not accept claims from dealers for transportation damage or installation of incorrectly shipped units.

9.1 PARTS

Inspect the unit to verify all required components are present and intact. Report any missing components immediately to the manufacturer or to the distributor. Use only factory authorized replacement parts (see Section 5). Make sure to include the full product model number and serial number when reporting and/or obtaining service parts.

9.2 HANDLING

Use caution when transporting / carrying the unit. Do not move unit using shipping straps. Do not carry unit with hooks or sharp objects. The preferred method of carrying the unit after arrival at the job site is to carry via a two-wheel hand truck from the back or sides or via hand by carrying at the cabinet corners.

9.3 SHIPPING MATERIAL REMOVAL

IMPORTANT: ALL SHIPPING MATERIAL USED TO PROTECT THE EQUIPMENT, AND THE EQUIPMENT'S COMPONENTS, DURING TRANSIT SHOULD BE REMOVED BEFORE FINAL INSTALLATION.

10 REPLACEMENT PARTS

When reporting shortages or damages, or ordering repair parts, give the complete product model and serial numbers as stamped on the product. Replacement parts for this product are available through your contractor or local distributor. Your nearest distributor can be located online at <https://partner.goodmanmfg.com/> or by contacting:

HOMEOWNER SUPPORT
DAIKIN COMFORT TECHNOLOGIES
MANUFACTURING, L.P.
19001 KERMIER ROAD
WALLER, TEXAS 77484
(855) 770-5678

Installer's Note:

Replacement air filters can be ordered directly from the supplier:

United Air Filter
Charlotte, NC
Phone: **704-334-5311**

AWSF/AWST 18-24 - Size: 14" x 18" x 1"
AWSF/AWST 30-36 - Size: 18" x 20" x 1"

11 PRE-INSTALLATION INSTRUCTIONS

11.1 PREPARATION

Keep this document with the unit. Carefully read all instructions for the installation prior to installing product. Make sure each step or procedure is understood and any special considerations are taken into account before starting installation. Assemble all tools, hardware, and supplies needed to complete the installation. Some items may need to be purchased locally. Make sure everything needed to install the product is on hand before starting.

Ensure that the area is in the open or that it is adequately ventilated before breaking into the system or conducting any hot work. A degree of ventilation shall continue during the period that the work is carried out. The ventilation should safely disperse any released refrigerant and preferably expel it externally into the atmosphere.

11.2 SYSTEM MATCHES

The entire system (combination of indoor and outdoor sections) must be manufacture approved and Air-conditioning, Heating, and Refrigeration Institute (AHRI) listed.

NOTE: Installation of unmatched systems is not permitted. Damage or repairs due to installation of unmatched systems is not covered under the warranty.

11.3 INTERCONNECTING TUBING

Give special consideration to minimize the length of refrigerant tubing when installing air handlers. Refer to Remote Cooling/ Heat Pump Service Manual RS6200006, and TP-110 Long Line Set Application R-32 for tubing guidelines. If possible, allow adequate length of tubing such that the coil may be removed (for inspection or cleaning services) from the cabinet without disconnecting the tubing.

Note: These air handlers are designed for indoor installation only at a max altitude of 10,500 feet above sea level or a min altitude of -184 feet below sea level.

If the unit is located in an unconditioned area with high ambient temperature and/or high humidity, the air handler may be subject to nuisance sweating of the casing. On these installations, a wrap of 2" fiberglass insulation with a vapor barrier is recommended. A secondary drain pan below the unit is also recommended to protect the installation site.

12 APPLICATION INFORMATION

The unit is designed to be installed in conditioned space, either recessed into a wall or hanging in a vertical "upflow" position. If units are recessed in a wall, use the holes along the inside of the front flange to attach units to the framing studs. The vertical air handler comes equipped with an offset hanging bracket attached to the rear of the cabinet for hanging applications.

IMPORTANT: Unit must be installed level or slightly tilted back to ensure proper drainage of condensate.

The air handler also has a bottom and front return. **Large chassis installations should be installed as front return only.** If the small chassis air handler is to be installed in a bottom return application, discard the drain access panel in the bottom of the unit. If the air handler is to be installed in a front return application, remove and discard the front access panel with insulation. The unit is shipped with a filter rack and filter. Remember to inspect, clean and/or replace the filter monthly.

Units are equipped with both a bottom primary and secondary drain. Both drains must be trapped, unless emergency condensate switch is install in the secondary drain. Failure to install a trap could result in condensation overflowing the drain pan resulting in substantial water damage to the nearby area.

The connectors required are 3/4" NPT male, either PVC or metal pipe, CPVC piping is not approved, and should be hand tightened to a torque of no more than 37 in-lbs. to prevent damage to the drain pan connection.

To prevent potential sweating and dripping on to finished space, it may be necessary to insulate the condensate drain line located inside the building. Use Armaflex® or similar material.



NOTE: If you intend to install this unit with a "WAD" door it must be mounted 1/4" behind front edge of stud.

13 ACHIEVING LOW AIR LEAKAGE RATE

Ensure all the gaskets remain intact on surfaces as shipped with the unit. When these requirements are satisfied, the unit achieves the following airflow leakage when tested in accordance with ASHRAE Standard 193:

- Cabinet air leakage less than 2% at 1.0 inch H2O
- Cabinet air leakage less than 1.4% at 0.5 inch H2O

14 START-UP PROCEDURE

 WARNING
<p>HIGH VOLTAGE! DISCONNECT ALL POWER BEFORE SERVICING OR INSTALLING THIS UNIT. MULTIPLE POWER SOURCES MAY BE PRESENT. FAILURE TO DO SO MAY CAUSE PROPERTY DAMAGE, PERSONAL INJURY OR DEATH.</p>

- Prior to start-up, ensure that all electrical wires are properly sized and all connections are properly tightened.
- All panels must be place and secured. For Air Tight application, gasket must be positioned at prescribed locations to achieve 1.4% leakage.
- Tubing must be leak free.
- Condensate line must be trapped and pitched to allow for drainage.

- Low voltage wiring is properly connected.
- Unit is protected from vehicular or other physical damage.
- Return air is not obtained from areas where there may be objectionable odors, flammable vapors or products of combustion such as carbon monoxide (CO), which may cause serious personal injury or death.

15 REFRIGERATION DETECTION SYSTEM (RDS)

Function: Refrigerant Detection System (RDS) is installed in this equipment to detect any R32 leakage in the coil and take action to mitigate any risk of ignition/ fire.

Operation: When there is leak detected, the RDS shall send signals for the unit to perform these actions:

1. Turn off the Thermal Stats
2. Turn on the blower for air circulation
3. Switch off electric heater

Servicing: Before servicing identify the Mode of operation of the system by reading the LED flashing pattern on the PCB which can be seen through the round glass view on top access panel and matching the LED flashing pattern with mode of operation in A2L PCB fault code label which is attached on the front side of the blower access panel (Figure 6 and 7). After identifying the mode of operation take recommended actions as specified in Table 8.

15.1 Detection of Refrigerant

Under no circumstances shall potential sources of ignition be used in the searching for or detection of refrigerant leaks. A halide torch (or any other detector using a naked flame) shall not be used. The following leak detection methods are deemed acceptable for all refrigerant systems. Electronic leak detectors may be used to detect refrigerant leaks but, in the case of FLAMMABLE REFRIGERANTS, the sensitivity may not be adequate, or may need re-calibration. (Detection equipment shall be calibrated in a refrigerant-free area.) Ensure that the detector is not a potential source of ignition and is suitable for the refrigerant used. Leak detection equipment shall be set at a percentage of the LFL of the refrigerant and shall be calibrated to the refrigerant employed, and the appropriate percentage of gas (25 % maximum) is confirmed. Leak detection fluids are also suitable for use with most refrigerants but the use of detergents containing chlorine shall be avoided as the chlorine may react with the refrigerant and corrode the copper pipe-work.

If a leak is suspected, all naked flames shall be removed/ extinguished. If a leakage of refrigerant is found which requires brazing, all of the refrigerant shall be recovered from the system, or isolated (by means of shut off valves) in a part of the system remote from the leak.

15.2 Removal and Evacuation

When breaking into the refrigerant circuit to make repairs – or for any other purpose – conventional procedures shall

be used. However, for flammable refrigerants it is important that best practice be followed, since flammability is a consideration. The following procedure shall be adhered to

The refrigerant charge shall be recovered into the correct recovery cylinders if venting is not allowed by local and national codes. For appliances containing flammable refrigerants, the system shall be purged with oxygen-free nitrogen to render the appliance safe for flammable refrigerants. This process might need to be repeated several times. Compressed air or oxygen shall not be used for purging refrigerant systems.

15.3 Refrigerant Recovery

When removing refrigerant from a system, either for servicing or decommissioning, it is recommended good practice that all refrigerants are removed safely.

When transferring refrigerant into cylinders, ensure that only appropriate refrigerant recovery cylinders are employed. Ensure that the correct number of cylinders for holding the total system charge is available. All cylinders to be used are designated for the recovered refrigerant and labelled for that refrigerant (i.e. special cylinders for the recovery of refrigerant). Cylinders shall be complete with pressure-relief valve and associated shut-off valves in good working order. Empty recovery cylinders are evacuated and, if possible, cooled before recovery occurs.

The recovery equipment shall be in good working order with a set of instructions concerning the equipment that is at hand and shall be suitable for the recovery of the flammable refrigerant. If in doubt, the manufacturer should be consulted. In addition, a set of calibrated weighing scales shall be available and in good working order. Hoses shall be complete with leak-free disconnect couplings and in good condition.

The recovered refrigerant shall be processed according to local legislation in the correct recovery cylinder, and the relevant waste transfer note arranged. Do not mix refrigerants in recovery units and especially not in cylinders.

If compressors or compressor oils are to be removed, ensure that they have been evacuated to an acceptable level to make certain that flammable refrigerant does not remain within the lubricant. The compressor body shall not be heated by an open flame or other ignition sources to accelerate this process. When oil is drained from a system, it shall be carried out safely.

15.4 R-32 Sensor Servicing Instructions

15.4.1 Sensor Dismounting Instructions

1. Dismount the front top access panel by unscrewing all the screws.

2. Remove the pin connecting the sensor cable on the PCB as shown in figures 6 and 7. Remove the filter from the air handler based on the following:
 - A. For AWSF/AWST 18-24 units, perform the following:
 - Remove the front bottom panel by unscrewing the 4 screws shown in figure 7 (In some cases it might have already been removed due to front return setup. Skip this step if that's the case).
 - Take out the filter by slowly sliding it out.
 - B. For AWSF/AWST 30-36 units, perform the following:
 - Rotate the sheet metal cover holding the filter.
 - Remove the filter.
3. Dismount the sensor bracket assembly by unscrewing the screws which hold the sensor bracket on the right gutter rail.
4. Remove the R-32 sensor cable by cutting and removing the cable tie without damaging the R-32 sensor cable.
5. Unscrew both the screws which hold the R-32 sensor on the sensor bracket.

15.4.2 Sensor Mounting Instructions:

1. Place the sensor on the sensor bracket such that the two holes on the sensor and sensor bracket align with each other.
2. Use two M0211216 screws to fasten the sensor on the sensor bracket using a torque drill using torque values of 15±5 in-lbs.
3. Mount the cable tie on the bottom left portion of the sensor bracket.
4. Place the R-32 sensor wire as shown in figures 6 and 7 and use the cable tie to secure and tie the R-32 sensor wire. Cut the edge of the cable tie.
5. Mount the sensor bracket assembly to the right gutter rail using two M0211216 screws.
6. Mount the filter back on the air handler based on following:
 - A. For AWSF/AWST 18-24 units, perform the following:
 - Put the filter by sliding it in slowly through the filter holder.
 - Mount the front bottom panel by screwing the 4 screws shown in figure 7 (In some cases it might have already been removed due to front return setup. Skip this step if that's the case).
 - B. For AWSF/AWST 30-36 units, perform the following:
 - Plate the filter as shown in the figure 6.
 - Rotate the sheet metal cover to hold the filter in place.

IMPORTANT: The R-32 Sensor shall only be replaced with sensors specified by the appliance manufacturing

15.5. A2L PCB Servicing Instructions:

Take off the front side of the access panel, Disconnect the PCB harness and R32 sensor wire connected to the PCB, detach the defective PCB from the four plastic standoffs, install new PCB on 4 plastic standoffs which is installed on metal bracket, re-connect the PCB harness and R32 sensor wire to the new PCB per wiring instruction as attached to the equipment, reassemble the front side of the access panel to the unit.

LEAK DETECTION SYSTEM INSTALLED. UNIT MUST BE POWERED EXCEPT FOR SERVICE.	
RED LED'S STATUS (REFER I/O FOR RECOMMENDED ACTION)	
MODE	LED FLASHING PATTERN
NORMAL OPERATION	SLOW LED FLASHING PATTERN (2 SECONDS ON 2 SECONDS OFF)
R-32 LEAK ALARM*	FAST LED FLASHING PATTERN
DELAY MODE	LED WILL BE ON CONTINUOUSLY
SYSTEM VERIFICATION MODE	SAME AS R32 LEAK ALARM MODE
CONTROL BOARD INTERNAL FAULT	LED WILL FLASH 2 TIMES AND THEN BE OFF FOR 5 SECONDS
R32 SENSOR COMMUNICATION FAULT	LED WILL FLASH 3 TIMES AND THEN BE OFF FOR 5 SECONDS
R32 SENSOR FAULT	LED WILL FLASH 4 TIMES AND THEN BE OFF FOR 5 SECONDS
*IF R-32 LEAK ALARM IS OBSERVED, DO NOT OPEN THE UNIT OR TURN IT OFF.	
 0140A01138-B	





A2L PCB FAULT CODE

TABLE 8

RED LED'S STATUS				
MODE	Definition	LED Flashing Pattern	Recommended actions	Notes:
1	Normal Operation	No faults to report	Slow LED flashing pattern (2 seconds on and 2 seconds off)	No action - life is good
2	R32 Leak Alarm	R32 leak is currently being detected	Fast LED Flashing Pattern	In terms of the controls, no action is needed. The controls and sensor are working fine. The contractor will need to figure out where the leak is coming from and address that but we're just talking about the control system here.
3	Delay Mode	After R32 leak or Alarm has been cleared, the unit will remain in alarm mode for 5 minutes before returning to normal operation	LED will be on continuously	No action needed - If the system was previously experiencing an actual R32 Leak, the refrigerant can no longer be detected by the sensor meaning it's either gone and the system won't work anymore or there was a false alarm. If the system was experiencing a Fault, the fault is gone and the system will return to normal operation in 5 min.
4	System Verification Mode	Manual test run by contractor to simulate R32 Leak Alarm (test will last for 5 minutes max)	Fast LED Flashing Pattern	No actions needed
5	Control Board Internal Fault	Control board has detected an issue with the R32 detection system	LED will flash 2 times and then be off for 5 seconds before repeating the pattern	1) Unplug and plug the R32 sensor back in. Cycle power to the system. 2) If control is in Normal Operation or Delay mode, there is no more issue. If not, continue with diagnostics 3) Unplug R32 sensor and leave unplugged. Cycle power to the system 4) If control still displays "Control Board Internal Fault" (2 flash pattern) replace the control. If control now displays "R32 Sensor Communication Fault" (3 flash pattern) replace the sensor
6	R32 Sensor Communication Fault	Control board does not have communications with R32 sensor	LED will flash 3 times and then be off for 5 seconds before repeating the pattern	1) Unplug and plug the R32 sensor back in. Cycle power to the system. 2) If control is in Normal Operation or Delay mode, there is no more issue. If not, continue with diagnostics 3) If control still displays "R32 Sensor Communication Fault" (3 flash pattern), Relace both the sensor and the PCB
7	R32 Sensor Fault	R32 Sensor has reported an internal issue	LED will blink 4 times and then be off for 5 seconds before repeating the pattern	replace R32 sensor

RECOMMENDED ACTION FOR PCB LED FLASHING CODES

TABLE 9

	service indicator; read technical manual
	operator's manual; operating instructions
	warning; low burning velocity material
	UN GHS flame symbol

MARKING SYMBOL TABLE

TABLE 10

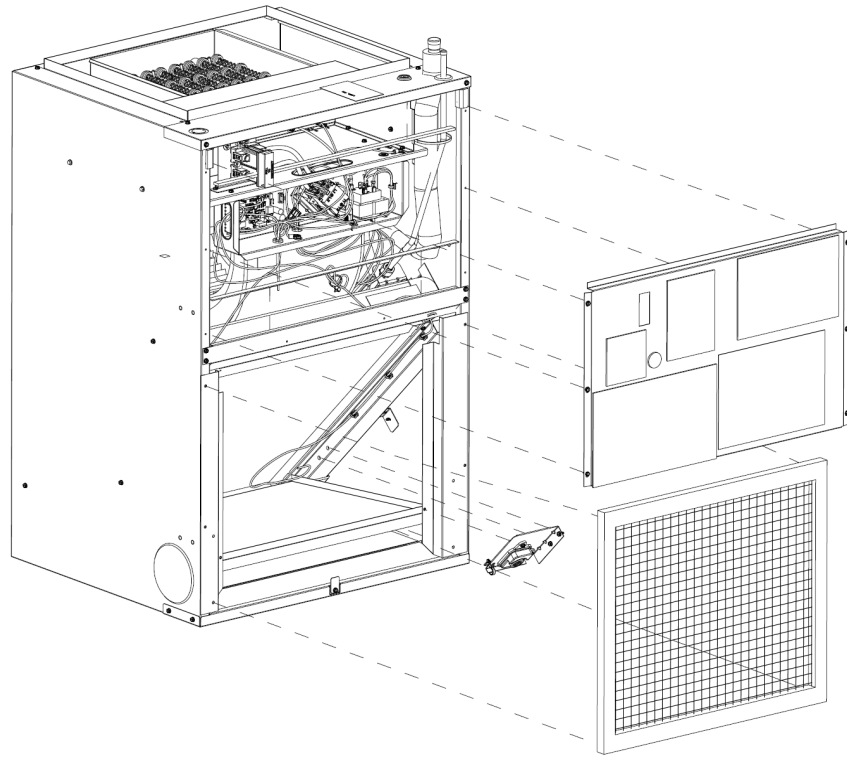

Figure 6

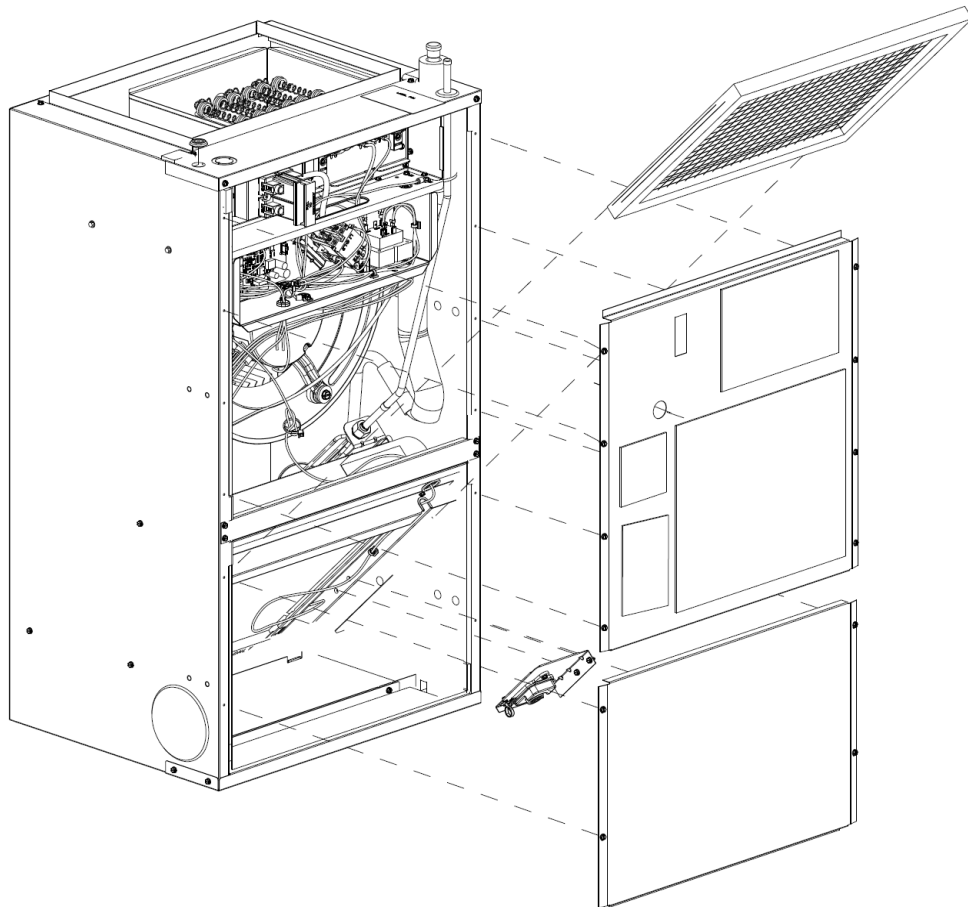

Figure 7

16 AWST-FACTORY INSTALLED TXV MODELS

AWST air handlers come equipped with a factory installed fully adjustable TXV, follow instruction below for installation procedure.

16.1 TUBING SIZE

For the correct tubing size, follow the specification for the condenser/heat pump.

16.2 TUBING CONNECTIONS

An adjustable TXV with bulb is installed on the vapor tube from the factory.

Note: The TXV must be adjustable to meet the outdoor unit's target superheat value. During the superheat adjustment on the TXV, the torque applied on the nut cannot exceed 25 in-lbs. Refer to the EXPANSION VALVE TROUBLESHOOTING section of this manual for assistance with the adjustable TXV. TXV Installation outside the coil is not allowed.

For air handler installation, follow the installation procedure below.

3. Remove the front access panel.
4. Remove access valve fitting red cap and depress the valve system to release pressure. No pressure indicates possible leak. Use tool to remove red valve cap in case it is too tight.
5. Replace the fitting cap.
6. Remove the copper cap on both the liquid line and suction line. The copper caps caused by the refrigerant lines. DO NOT USE ANY FORM OF CUTTING METHOD. CUTTING THE CAPS MAY RESULT IN THE GENERATION OF COPPER SHAVINGS OR COPPER DUST.
7. Insert liquid line into liquid tube expansion and slide grommet about 18" away from braze joint.
8. Braze suction line set into suction tube expansion and slide insulation about 18" away from braze joint.
9. Braze joints and quench all brazed joints with water or wet rag upon completion of brazing.
10. Ensure no wet rags or debris left inside cabinet before closing cabinet.
11. Ensure to replace and finger-tight red valve cap on access fitting.

16.3 THERMAL EXPANSION VALVE SYSTEM ADJUSTMENT

The following information for the indoor unit should be verified before attempting to charge system or adjust TXV if necessary.

1. Total static pressure is .3" WC or less.
2. Airflow is correct for installed unit.
3. Airflow tables are in the installation manual and Spec Sheet for Indoor Unit.
4. Complete airflow tables and charging information are in Service Manual RS6200006.
5. The outdoor temperature must be 60°F or higher.
6. Set the room thermostat to COOL, fan switch to AUTO
7. Set temperature control well below room temperature.

Superheat adjustments should not be made until indoor ambient conditions have stabilized. This could take up to 24 hours depending on the indoor temperature and humidity. Before checking superheat run the unit in cooling for 10 minutes or until refrigerant pressures stabilize. Use the following guidelines and methods to check unit operation and ensure that the refrigerant charge is within limits.

In addition to conventional charging procedures, the following requirements shall be followed:

1. Ensure that contamination of different refrigerants does not occur when using charging equipment. Hoses or lines shall be as short as possible to minimize the amount of refrigerant contained in them.
2. A2L Refrigerant Cylinders shall be kept in an appropriate position according to the instructions.
3. Ensure that the refrigeration system is earthed prior to charging the system with refrigerant.
4. Label the system when charging is complete (if not already).
5. Extreme care shall be taken not to overfill the refrigerating system

Prior to recharging the system, it shall be pressure-tested with the appropriate purging gas. The system shall be leak-tested on completion of charging, but prior to commissioning. A follow-up leak test shall be carried out prior to leaving the site.

1. Purge gauge lines. Connect service gauge manifold to base-valve service ports.
2. Temporarily install a thermometer on the liquid line at the liquid line service valve and 4-6" from the compressor on the suction line. Ensure the thermometer makes adequate contact and is insulated for best possible readings. Use liquid line temperature to determine subcooling and vapor temperature to determine superheat.
3. Check subcooling and superheat. The system should have a subcooling of 8°F +/- 1°F and superheat of 8°F +/- 1°F. If subcooling and superheat are low, adjust TXV to 8°F +/- 1°F superheat, then check subcooling.
 - A. If subcooling is low and superheat is high, add charge to raise subcooling to 8°F +/- 1°F, then check superheat.
 - B. If subcooling and superheat are high, adjust TXV valve to 8°F +/- 1°F superheat, then check subcooling.

For optimum system performance subcool and superheat should be matched as specified in Outdoor Installation and Instruction manual. Outdoor should be matched with approved AHRI combination, other approved system shall have subcooling set to 8°F ± 1°F and superheat set to 12°F ± 1°F.

Superheat Adjustments (Only if necessary)

1. Attach a pipe clamp thermometer near the suction line service valve at the outdoor unit.
 - A. Ensure the thermometer makes adequate contact for the best possible readings.
2. TXV-based systems should have a Superheat value of 8°F +/- 1°F.
3. Adjust Superheat by turning the TXV valve stem clockwise to **increase** and **counterclockwise** to **decrease**. Adjustments should be made opening or closing the valve by no more than 1/4 turn at a time. Allow the system to stabilize to 15 to 20 minutes before making additional adjustments if necessary.
4. After adjustments are complete replace red valve cap on adjustment stem and finger-tight the red valve cap.
5. Remove gauges and check the Schrader ports for leaks and tighten valve cores if necessary. Install red valve caps finger tight.



WARNING

THIS PRODUCT IS FACTORY-SHIPED WITH DRY NITROGEN MIXTURE GAS UNDER PRESSURE. USE APPROPRIATE SERVICE TOOLS AND FOLLOW THESE INSTRUCTIONS TO PREVENT INJURY.

17 AWSF FIXED ORIFICE ADJUSTMENT



CAUTION

TO PREVENT PERSONAL INJURY, CAREFULLY CONNECT AND DISCONNECT MANIFOLD GAUGE HOSES. ESCAPING LIQUID REFRIGERANT CAN CAUSE BURNS. DO NOT VENT REFRIGERANT INTO THE ATMOSPHERE. RECOVER ALL REFRIGERANT DURING SYSTEM REPAIR AND BEFORE FINAL UNIT DISPOSAL.

Note: Piston installation outside the coil is not allowed

1. Purge gauge lines. Connect service gauge manifold to base -valve service ports. run system at least 10minutes to allow pressure to stabilize.
2. Temporarily install a thermometer 4-6" from the compressor on the suction line. ensure the thermometer makes adequate contact and is insulated for best possible readings Use vapor temperature to determine superheat.
3. Refer to the superheat table provided for proper system superheat. Add charge to lower superheat or recover charge to raise superheat.
4. Disconnect manifold set, installation is complete.
Superheat Formula = Suct. Line Temp. - Sat. Suct. Temp.

For optimum system performance superheat should be matched as specified in Outdoor Installation and Instruction Manual.

18 EXPANSION VALVE TROUBLESHOOTING

Before replacing an expansion valve, check the following items:

1. Bulb location: Must be tightly secured to the suction line upstream of the equalizer connection.
2. Insulation: Bulb must be properly insulated.
3. Equalizer: Must be connected to the 1/4" SAE connection on the suction line.
4. Charge: Ensure the system is properly charged. There MUST be a minimum of 10°F Sub-Cooled liquid at the valve inlet.

If the system appears to be "starving" (low suction pressure but insufficient cooling):

1. Check the Superheat (SH) at the evaporator outlet. If SH is between 5°F - 12°F, the TXV is controlling properly.
 - Verify that there is proper airflow to the evaporator (fan is operating and filter is unrestricted).
2. If SH is above 12°F, the setting of the TXV may be too high.
 - Adjust the SH by turning counter-clockwise to decrease SH.
 - Wait 20 minutes for the system to balance and adjust again, as required.
 - If adjusting the valve has no effect on the SH, the valve may be stuck because of dirt or debris or it may have lost the Power Element charge.
3. After properly reclaiming the refrigerant, remove the TXV and check for dirt and debris. Clean, if possible, or replace the TXV and filter/drier.

If the system appears to be "flooding" (compressor frosting or moisture is condensing at the suction connection):

1. Check the SH at the evaporator outlet. If SH is between 5°F - 12°F, the TXV is controlling properly.
2. If SH is less than 5°F, the SH adjustment may be too low.
 - Adjust the SH by turning the adjustment stem clockwise to increase the SH.
 - Wait 20 minutes for the system to balance and adjust again as required.
 - If adjusting the valve has no effect on the SH, the valve may be stuck open because of dirt or debris or moisture in the refrigerant.
3. After properly reclaiming the refrigerant, remove the TXV and check for dirt and debris. Clean, if possible, or replace the TXV and filter/drier. Add a moisture indicator to allow checking of moisture if this is believed to be a probable cause.

19 MAINTENANCE

Periodic Checkup and Service

This unit is designed to provide many years of dependable, trouble-free comfort when properly maintained. Proper maintenance will consist of annual checkups and cleaning of the internal electrical and heat transfer components by a qualified service technician. Failure to provide periodic checkup and cleaning can result in excessive operating cost and/or equipment malfunction.

SPLIT SYSTEMS

AIR CONDITIONING AND HEAT PUMP HOMEOWNER'S ROUTINE MAINTENANCE RECOMMENDATIONS

We strongly recommend a biannual maintenance checkup be performed before the heating and cooling seasons begin by a qualified servicer.

Replace or Clean Filter

IMPORTANT NOTE: Never operate unit without a filter installed as dust and lint will build up on internal parts resulting in loss of efficiency, equipment damage and possible fire.

An indoor air filter must be used with your comfort system. A properly maintained filter will keep the indoor coil of your comfort system clean. A dirty coil could cause poor operation and/or severe equipment damage.

Your air filter or filters could be located in your furnace, in a blower unit, or in "filter grilles" in your ceiling or walls. The installer of your air conditioner or heat pump can tell you where your filter(s) are, and how to clean or replace them.

Check your filter(s) at least once a month. When they are dirty, replace or clean as required. Disposable type filters should be replaced.

Reusable type filters may be cleaned.

You may want to ask your dealer about high efficiency filters. High efficiency filters are available in both electronic and non-electronic types.

These filters can do a better job of catching small airborne particles.

Compressor

The compressor motor is hermetically sealed and does not require additional oiling.

Motors

Indoor and outdoor fan motors are permanently lubricated and do not require additional oiling.

Aluminum Indoor Coil Cleaning (Qualified Servicer Only)

A2L sensor must be removed from the unit before applying coil cleaners to avoid damage and contamination. This unit is equipped with an aluminum tube evaporator coil. The safest way to clean the evaporator coil is to simply flush the coil with water. This cleaning practice remains as the recommended cleaning method for both copper tube and aluminum tube residential cooling coils.

An alternate cleaning method is to use one of the products listed in the technical publication **TP-109*** (shipped in the literature bag with the unit) to clean the coils. The cleaners listed are the only agents deemed safe and approved for use to clean round tube aluminum coils. TP-109 is available on the web site in Partner Link > Service Toolkit.

NOTE: Ensure coils are rinsed well after use of any chemical cleaners.

Clean Outside Coil (Qualified Servicer Only)

Air must be able to flow through the outdoor unit of your comfort system. Do not construct a fence near the unit or build a deck or patio over the unit without first discussing your plans with your dealer or other qualified servicer. Restricted airflow could lead to poor operation and/or severe equipment damage.

Likewise, it is important to keep the outdoor coil clean. Dirt, leaves, or debris could also restrict the airflow. If cleaning of the outdoor coil becomes necessary, hire a qualified servicer. Inexperienced people could easily puncture the tubing in the coil. Even a small hole in the tubing could eventually cause a large loss of refrigerant. Loss of refrigerant can cause poor operation and/or severe equipment damage.

Do not use a condensing unit cover to "protect" the outdoor unit during the winter, unless you first discuss it with your dealer. Any cover used must include "breathable" fabric to avoid moisture buildup.

BEFORE CALLING YOUR SERVICER

- Check the thermostat to confirm that it is properly set.
- Wait 15 minutes. Some devices in the outdoor unit or in programmable thermostats will prevent compressor operation for awhile, and then reset automatically. Also, some power companies will install devices which shut off air conditioners for several minutes on hot days. If you wait several minutes, the unit may begin operation on its own.
- Check the electrical panel for tripped circuit breakers or failed fuses. Reset the circuit breakers or replace fuses as necessary.
- Check the disconnect switch near the indoor furnace or blower to confirm that it is closed.
- Check for obstructions on the outdoor unit. Confirm that it has not been covered on the sides or the top. Remove any obstruction that can be safely removed. If the unit is covered with dirt or debris, call a qualified servicer to clean it.
- Check for blockage of the indoor air inlets and outlets. Confirm that they are open and have not been blocked by objects (rugs, curtains or furniture).
- Check the filter. If it is dirty, clean or replace it.
- Listen for any unusual noise(s), other than normal operating noise, that might be coming from the outdoor unit. If you hear unusual noise(s) coming from the unit, call a qualified servicer.



WARNING

HIGH VOLTAGE

DISCONNECT ALL POWER BEFORE SERVICING OR INSTALLING THIS UNIT. MULTIPLE POWER SOURCES MAY BE PRESENT. FAILURE TO DO SO MAY CAUSE PROPERTY DAMAGE, PERSONAL INJURY OR DEATH.



CAUTION

TO AVOID THE RISK OF EQUIPMENT DAMAGE OR FIRE, INSTALL THE SAME AMPERAGE BREAKER OR FUSE AS YOU ARE REPLACING. IF THE CIRCUIT BREAKER OR FUSE SHOULD OPEN AGAIN WITHIN THIRTY DAYS, CONTACT A QUALIFIED SERVICER TO CORRECT THE PROBLEM. IF YOU REPEATEDLY RESET THE BREAKER OR REPLACE THE FUSE WITHOUT HAVING THE PROBLEM CORRECTED, YOU RUN THE RISK OF SEVERE EQUIPMENT DAMAGE.

20 START-UP CHECKLIST

Air Handler / Coil			
	Model Number	_____	
	Serial Number	_____	
ELECTRICAL			
Line Voltage (Measure L1 and L2 Voltage)	L1 - L2	_____	
Secondary Voltage (Measure Transformer Output Voltage)	R - C	_____	
Blower Amps		_____	
Heat Strip 1 - Amps		_____	
Heat Strip 2 - Amps		_____	
BLOWER EXTERNAL STATIC PRESSURE			
Return Air Static Pressure		_____	IN. W.C.
Supply Air Static Pressure		_____	IN. W.C.
Total External Static Pressure (Ignoring +/- from the reading above, add total here)		_____	IN. W.C.
TEMPERATURES			
Return Air Temperature (Dry bulb / Wet bulb)	_____	DB °F	_____ WB °F
Cooling Supply Air Temperature (Dry bulb / Wet bulb)	_____	DB °F	_____ WB °F
Heating Supply Air Temperature	_____	DB °F	
Temperature Rise	_____	DB °F	
Delta T (Difference between Supply and Return Temperatures)	_____	DB °F	
Air Handler / Coil - (Inverter Matched)			
INVERTER AH / COIL ONLY			
Check EEV and EEV wiring is secure (no adjustment required)		_____	
Additional Checks			
Check wire routings for any rubbing		_____	
Check product for proper draining		_____	
Check screw tightness on blower wheel		_____	
Check factory wiring and wire connections		_____	
Check product for proper clearances as noted by installation instructions		_____	
°F to °C formula: (°F - 32) divided by 1.8 = °C °C to °F formula: (°C multiplied by 1.8) + 32 = °F			

CUSTOMER FEEDBACK

We are very interested in all product comments.

Please fill out the feedback form on one of the following links:

Daikin Products: (<https://daikincomfort.com/contact-us>)

Goodman® Brand Products: (<http://www.goodmanmfg.com/about/contact-us>).

Amana® Brand Products: (<http://www.amana-hac.com/about-us/contact-us>).

You can also scan the QR code on the right for the product brand you purchased to be directed to the feedback page.



DAIKIN



GOODMAN® BRAND



AMANA® BRAND

PRODUCT REGISTRATION

Thank you for your recent purchase. Though not required to get the protection of the standard warranty, registering your product is a relatively short process, and entitles you to additional warranty protection, except that failure by California and Quebec residents to register their product does not diminish their warranty rights. The duration of warranty coverages in Texas and Florida differs in some cases.

For Product Registration, please register as follows:

Daikin Products: (<https://daikincomfort.com/owner-support/product-registration>).

Goodman® Brand products: (<https://www.goodmanmfg.com/product-registration>).

Amana® Brand products: (<http://www.amana-hac.com/product-registration>).

You can also scan the QR code on the right for the product brand you purchased to be directed to the Product Registration page.



DAIKIN



GOODMAN® BRAND



AMANA® BRAND

NOTE: SPECIFICATIONS AND PERFORMANCE DATE LISTED HEREIN ARE SUBJECT TO CHANGE WITHOUT NOTICE.

Visit our website at www.daikincomfort.com, www.goodmanmfg.com or www.amana-hac.com for information on:

- Products
- Warranties
- Customer Services
- Parts
- Contractor Programs and Training
- Financing Options

Daikin Comfort Technologies Manufacturing, L.P.

19001 Kermier Rd., Waller, TX 77484

© 2023

Amana is a registered trademark of Maytag Corporation or its related companies and is used under license. All rights reserved.