

CAHEA***C3** SERIES MULTIPOSITION COIL - COLD CLIMATE INSTALLATION INSTRUCTIONS

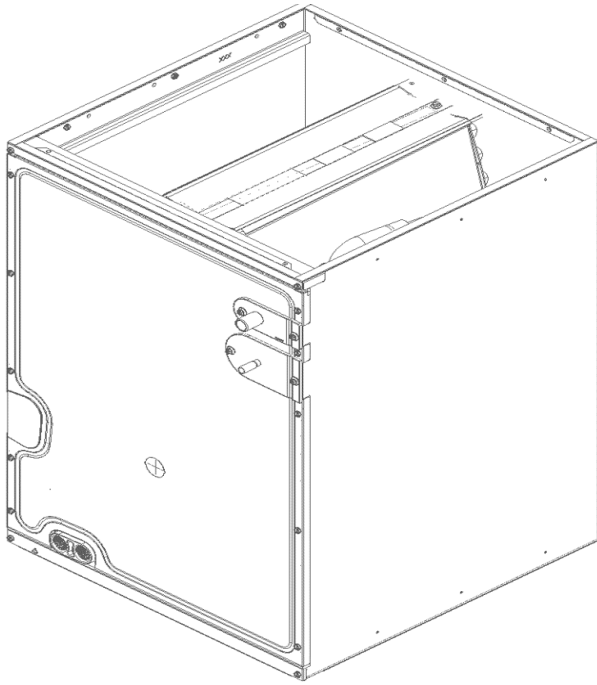

 **RECOGNIZE THIS SYMBOL
AS A SAFETY PRECAUTION.**



WARNING: FLAMMABLE MATERIALS

DO NOT USE MEANS TO ACCELERATE THE DEFROSTING PROCESS OR TO CLEAN, OTHER THAN THOSE RECOMMENDED BY THE MANUFACTURER. THE APPLIANCE SHALL BE STORED IN A ROOM WITHOUT CONTINUOUSLY OPERATING IGNITION SOURCES (FOR EXAMPLE: OPEN FLAMES, AN OPERATING GAS APPLIANCE OR AN OPERATING ELECTRIC HEATER. DO NOT PIERCE OR BURN. BE AWARE THAT REFRIGERANTS MAY NOT CONTAIN AN ODOR.



WARNING

DO NOT BYPASS SAFETY DEVICES.



WARNING

ONLY PERSONNEL THAT HAVE BEEN TRAINED TO INSTALL, ADJUST, SERVICE, MAINTENANCE OR REPAIR (HEREINAFTER, "SERVICE") THE EQUIPMENT SPECIFIED IN THIS MANUAL SHOULD SERVICE THE EQUIPMENT.

THIS EQUIPMENT IS NOT INTENDED FOR USE BY PERSONS (INCLUDING CHILDREN) WITH REDUCED PHYSICAL, SENSORY OR MENTAL CAPABILITIES, OR LACK OF EXPERIENCE AND KNOWLEDGE, UNLESS THEY HAVE BEEN GIVEN SUPERVISION OR INSTRUCTION CONCERNING USE OF THE APPLIANCE BY A PERSON RESPONSIBLE FOR THEIR SAFETY.

CHILDREN SHOULD BE SUPERVISED TO ENSURE THAT THEY DO NOT PLAY WITH THE EQUIPMENT.

THE MANUFACTURER WILL NOT BE RESPONSIBLE FOR ANY INJURY OR PROPERTY DAMAGE ARISING FROM IMPROPER SUPERVISION, SERVICE OR SERVICE PROCEDURES. IF YOU SERVICE THIS UNIT, YOU ASSUME RESPONSIBILITY FOR ANY INJURY OR PROPERTY DAMAGE WHICH MAY RESULT. IN ADDITION, IN JURISDICTIONS THAT REQUIRE ONE OR MORE LICENSES TO SERVICE THE EQUIPMENT SPECIFIED IN THIS MANUAL, ONLY LICENSED PERSONNEL SHOULD SERVICE THE EQUIPMENT. IMPROPER SUPERVISION, INSTALLATION, ADJUSTMENT, SERVICING, MAINTENANCE OR REPAIR OF THE EQUIPMENT SPECIFIED IN THIS MANUAL, OR ATTEMPTING TO INSTALL, ADJUST, SERVICE OR REPAIR THE EQUIPMENT SPECIFIED IN THIS MANUAL WITHOUT PROPER SUPERVISION OR TRAINING MAY RESULT IN PRODUCT DAMAGE, PROPERTY DAMAGE, PERSONAL INJURY OR DEATH.



WARNING





PAIRED WITH COLD CLIMATE HEAT PUMP (CCHP) MODULAR BLOWER ONLY.

Our continuing commitment to quality products may mean a change in specifications without notice



QUEBEC DISCLOSURE REGARDING AVAILABILITY OF REPLACEMENT PARTS, REPAIR SERVICES AND INFORMATION FOR MAINTENANCE AND REPAIR: Daikin Comfort Technologies Manufacturing, Inc. (Daikin) does not guarantee the availability of (1) replacement parts; (2) repair services; and (3) information necessary to maintain or repair products, within the meaning of section 39.1 of the Consumer Protection Act, CQLR, c P-40.1 and section 79.18 of the Regulation respecting the application of the Consumer Protection Act, CQLR, c P-40.1, r. 3.

AVIS POUR LE QUÉBEC CONCERNANT LA DISPONIBILITÉ DES PIÈCES DE RECHANGE, DES SERVICES DE RÉPARATION ET DES RENSEIGNEMENTS POUR L'ENTRETIEN ET LA RÉPARATION : Daikin Comfort Technologies Manufacturing, Inc. (Daikin) ne garantit pas la disponibilité (1) des pièces de rechange, (2) des services de réparation et (3) des renseignements pour l'entretien et la réparation, au sens de l'article 39.1 de la Loi sur la protection du consommateur, RLRQ c P-40.1 et de l'article 79.18 du Règlement d'application de la Loi sur la protection du consommateur, RLRQ c P-40.1, r 3.

	service indicator; read technical manual
	operator's manual; operating instructions
	warning; Flammable materials
	UN GHS flame symbol

Marking Symbol Table



TABLE OF CONTENTS

1 Important Safety Instructions.....2
 2 Shipping Inspection.....4
 2.1 Parts.....4
 2.2 Handling.....4
 3 Codes & Regulations.....4
 4 Replacement Parts.....4
 5 Pre-Installation Considerations.....4
 5.1 Preparation.....4
 5.2 System Matches.....5
 5.3 Clearances.....5
 5.4 Access.....5
 6 Application Information.....5
 6.1 Upflow Installation.....8
 6.2 Downflow Installation.....8
 6.3 Horizontal Left and Right Installation.....8
 7 Return Ductwork.....9
 8 UV Accessory (Optional).....9
 9 Refrigerant Piping Work.....9
 9.1 Tubing Size/Length.....10
 9.2 Tubing Connection.....10
 9.3 System Pressure Testing.....11
 9.4 System Evacuation.....11
 10 Sealing Along The Panel Gap.....11
 11 Drain Piping Work.....11
 Cased Coil Homeowners Routine Maintenance Recommendations.....15
 Start-Up Checklist.....17

1 IMPORTANT SAFETY INSTRUCTIONS

The following symbols and labels are used throughout this manual to indicate immediate or potential safety hazards. It is the owner's and installer's responsibility to read and comply with all safety information and instructions accompanying these symbols. Failure to heed safety information increases the risk of personal injury, property damage, and/or product damage.

NOTICE: THIS PRODUCT CONTAINS ELECTRONIC COMPONENTS WHICH REQUIRE A DEFINITE GROUND. PROVISIONS ARE MADE FOR CONNECTION OF THE GROUND. A DEDICATED GROUND FROM THE MAIN POWER SUPPLY OR AN EARTH GROUND MUST BE PROVIDED.

 WARNING	
<p>HIGH VOLTAGE DISCONNECT ALL POWER BEFORE SERVICING OR INSTALLING THIS UNIT. MULTIPLE POWER SOURCES MAY BE PRESENT. FAILURE TO DO SO MAY CAUSE PROPERTY DAMAGE, PERSONAL INJURY OR DEATH.</p>	
 WARNING	
<p>TO PREVENT THE RISK OF PROPERTY DAMAGE, PERSONAL INJURY, OR DEATH, DO NOT STORE COMBUSTIBLE MATERIALS OR USE GASOLINE OR OTHER FLAMMABLE LIQUIDS OR VAPORS IN THE VICINITY OF THIS UNIT.</p>	



WARNING

DO NOT CONNECT TO OR USE ANY DEVICE THAT IS NOT CERTIFIED BY THE MANUFACTURER FOR USE WITH THIS UNIT. SERIOUS PROPERTY DAMAGE, PERSONAL INJURY, REDUCED UNIT PERFORMANCE AND/OR HAZARDOUS CONDITIONS MAY RESULT FROM THE USE OF SUCH NON-APPROVED DEVICES.



WARNING

FAILURE TO PROPERLY CONNECT REFRIGERANT LEAK SENSOR, EEV, PRESSURE SENSOR, AND THERMISTOR FROM CASED COIL TO MODULAR BLOWER WILL RESULT IN ERROR CODES AND THE UNIT NOT OPERATING.



WARNING

TO AVOID PROPERTY DAMAGE, PERSONAL INJURY OR DEATH DUE TO ELECTRICAL SHOCK, THIS UNIT MUST HAVE AN UNINTERRUPTED, UNBROKEN ELECTRICAL GROUND. THE ELECTRICAL GROUND CIRCUIT MAY CONSIST OF AN APPROPRIATELY SIZED ELECTRICAL WIRE CONNECTING THE GROUND LUG IN THE UNIT CONTROL BOX TO THE BUILDING ELECTRICAL SERVICE PANEL. OTHER METHODS OF GROUND ARE PERMITTED IF PERFORMED IN ACCORDANCE WITH THE NATIONAL ELECTRIC CODE (NEC)/ AMERICAN NATIONAL STANDARDS INSTITUTE (ANSI)/ NATIONAL FIRE PROTECTION ASSOCIATION (NFPA) 70 AND LOCAL/STATE CODES. IN CANADA, ELECTRICAL GROUNDING IS TO BE IN ACCORDANCE WITH THE CANADIAN ELECTRIC CODE (CSA) C22.1.



WARNING

DO NOT PAIR THIS CASED COIL WITH FURNACE. LOW VOLTAGE POWER NEEDED FOR CASED COIL COMPONENTS ARE PROVIDED BY THE MATCHING MODULAR BLOWER PC BOARD. DO NOT CONFIGURE THIS CASED COIL WITH ANY OTHER POWER SUPPLY.



WARNING

WHEN INSTALLING OR SERVICING THIS EQUIPMENT, SAFETY CLOTHING, INCLUDING HAND AND EYE PROTECTION, IS STRONGLY RECOMMENDED. IF INSTALLING IN AN AREA THAT HAS SPECIAL REQUIREMENTS (HARD HATS, ETC.), OBSERVE THESE REQUIREMENTS.



WARNING

FAILURE TO PROPERLY RECONNECT SENSOR WIRES MAY RESULT IN ERROR CODES AND THE UNIT NOT OPERATING.



WARNING

A REFRIGERANT LEAK DETECTION SYSTEM IS INSTALLED. THE UNIT MUST BE POWERED ON ALL TIMES EXCEPT FOR SERVICE.



DANGER PELIGRO

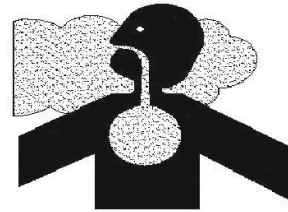

CARBON MONOXIDE POISONING HAZARD

Special Warning for Installation of Furnace or Air Handling Units in Enclosed Areas such as Garages, Utility Rooms or Parking Areas

Carbon monoxide producing devices (such as an automobile, space heater, gas water heater, etc.) should not be operated in enclosed areas such as unventilated garages, utility rooms or parking areas because of the danger of carbon monoxide (CO) poisoning resulting from the exhaust emissions. If a furnace or air handler is installed in an enclosed area such as a garage, utility room or parking area and a carbon monoxide producing device is operated therein, there must be adequate, direct outside ventilation.

This ventilation is necessary to avoid the danger of CO poisoning which can occur if a carbon monoxide producing device continues to operate in the enclosed area. Carbon monoxide emissions can be (re)circulated throughout the structure if the furnace or air handler is operating in any mode.

CO can cause serious illness including permanent brain damage or death.

B10259-216

RIESGO DE INTOXICACIÓN POR MONÓXIDO DE CARBONO

Advertencia especial para la instalación de calentadores ó manejadoras de aire en áreas cerradas como estacionamientos ó cuartos de servicio.

Los equipos ó aparatos que producen monóxido de carbono (tal como automóvil, calentador de gas, calentador de agua por medio de gas, etc) no deben ser operados en áreas cerradas debido al riesgo de envenenamiento por monóxido de carbono (CO) que resulta de las emisiones de gases de combustión. Si el equipo ó aparato se opera en dichas áreas, debe existir una adecuada ventilación directa al exterior.

Esta ventilación es necesaria para evitar el peligro de envenenamiento por CO, que puede ocurrir si un dispositivo que produce monóxido de carbono sigue operando en el lugar cerrado.

Las emisiones de monóxido de carbono pueden circular a través del aparato cuando se opera en cualquier modo.

El monóxido de carbono puede causar enfermedades severas como daño cerebral permanente ó muerte.

B10259-216

RISQUE D'EMPOISONNEMENT AU MONOXYDE DE CARBONE

Avvertissement special au sujet de l'installation d'appareils de chauffage ou de traitement d'air dans des endroits clos, tels les garages, les locaux d'entretien et les stationnements.

Evitez de mettre en marche les appareils produisant du monoxyde de carbone (tels que les automobile, les appareils de chauffage autonome, etc.) dans des endroits non ventilés tels que les d'empoisonnement au monoxyde de carbone. Si vous devez faire fonctionner ces appareils dans un endroit clos, assurez-vous qu'il y ait une ventilation directe provenant de l'exterieur.

Cette ventilation est nécessaire pour éviter le danger d'intoxication au CO pouvant survenir si un appareil produisant du monoxyde de carbone continue de fonctionner au sein de la zone confinée.

Les émissions de monoxyde de carbone peuvent être recirculés dans les endroits clos, si l'appareil de chauffage ou de traitement d'air sont en marche.

Le monoxyde de carbone peut causer des maladies graves telles que des dommages permanents au cerveau et même la mort.

B10259-216

2 SHIPPING INSPECTION

Upon receiving the product, inspect the unit for shipping damage. Shipping damage and subsequent investigation is the responsibility of the carrier. Verify the model number, specifications, electrical characteristics and accessories are correct prior to installation. The distributor or manufacturer will not accept claims from dealers for transportation damage or installation of incorrectly shipped units.

2.1 Parts

Also inspect the unit to verify all required components are present and intact. Report any missing components immediately to the distributor. Use only factory authorized replacement parts (see Section 4). Make sure to include the full product model number and serial number when reporting and/or obtaining service parts. The Unit is supplied along with Literature Kit Assembly consisting of AL COIL-APPROVED CLEANING LIST, IO Manual, and information on where to obtain a full copy of the Product Warranty

2.2 Handling

Use caution when handling the unit. Do not carry unit with hooks or sharp objects. The preferred method of carrying the unit after arrival at the job site is by two-wheel hand truck from the back or sides or by hand carrying at the cabinet corners. Take proper precautions when carrying/handling unit to avoid any damage to the piping.

	WARNING
<p>IF ANY HOT WORK IS TO BE CONDUCTED ON THE REFRIGERATING EQUIPMENT OR ANY ASSOCIATED PARTS, APPROPRIATE FIRE EXTINGUISHING EQUIPMENT SHALL BE AVAILABLE ON HAND. HAVE A DRY POWDER OR CO2 FIRE EXTINGUISHER ADJACENT TO THE HOT WORK AREA.</p> <p>ENSURE THAT THE AREA IS IN THE OPEN OR THAT IT IS ADEQUATELY VENTILATED BEFORE BREAKING INTO THE SYSTEM OR CONDUCTING ANY HOT WORK. A DEGREE OF VENTILATION SHALL CONTINUE DURING THE PERIOD THAT THE WORK IS CARRIED OUT. THE VENTILATION SHOULD SAFELY DISPERSE ANY RELEASED REFRIGERANT AND PREFERABLY EXPEL IT EXTERNALLY INTO THE ATMOSPHERE.</p>	

3 CODES & REGULATIONS

This product is designed and manufactured to comply with applicable national codes such as ASHRAE 15, ASHRAE 15.2, IAPMO Uniform Mechanical Code, ICC International Mechanical Code, or CSA B52. Installation in accordance with such codes and/or prevailing local codes/regulations is the responsibility of the installer. The manufacturer assumes no responsibility for equipment installed in violation of any codes or regulations.

The United States Environmental Protection Agency (EPA) has issued various regulations regarding the introduction and disposal of refrigerants. Failure to follow these regulations may harm the environment and can lead to the imposition of substantial fines. Should you have any questions please contact the local office of the EPA and/or refer to the EPA's website www.epa.gov.

NOTE: The installer must refer to section 5.1, table 1 and table 2 for the maximum possible refrigerant charge and minimum (air conditioned) room area which must be recorded on the serial plate.

4 REPLACEMENT PARTS

When reporting shortages or damages, or ordering repair parts, give the complete product model and serial numbers as stamped on the product.

Replacement parts for this product are available through your contractor or local distributor. Your nearest distributor can be located online at www.daikincomfort.com or by contacting:

HOMEOWNER SUPPORT
DAIKIN COMFORT TECHNOLOGIES
MANUFACTURING, INC.
19001 KERMIER ROAD,
WALLER, TX 77484
855-770-5678

The appliance shall be installed in accordance with national wiring regulations. This product was tested at an external static pressure up to 0.6 WC. None of the components in this product line are designed or approved to be suitable for outdoor use.

Cased Coil Mitigation Chart

Total System Refrigerant Charge	Maximum Possible Refrigerant Charge	Maximum Possible Refrigerant Charge	Minimum Air Conditioned Room Area	Minimum Air Conditioned Room Area	Minimum Required Mitigation Airflow	Minimum Required Mitigation Airflow
(oz)	(oz)	(kg)	(ft ²)	(m ²)	(CFM)	(m ³ /hr)
31~50	50	1.42	46	4.22	83	140
51~100	100	2.84	91	8.44	165	279
101~150	150	4.26	137	12.66	247	418
151~200	200	5.67	182	16.85	328	556
201~250	250	7.09	227	21.07	410	696
251~300	300	8.51	273	25.29	492	835
301~350	350	9.93	318	29.51	574	974
351~400	400	11.34	363	33.69	655	1112
401~450	450	12.76	409	37.91	737	1251
451~500	500	14.18	454	42.13	819	1391
501~550	550	15.60	499	46.35	901	1530
551~600	600	17.01	545	50.54	982	1668

Table 1

It is the installer’s responsibility to verify that actuation of mitigation procedures are operational with minimum required airflow according to the chart.

5.1 Preparation

Keep this document with the unit. Carefully read all instructions for the installation prior to installing product. Make sure each step or procedure is understood and any special considerations are taken into account before starting installation. Assemble all tools, hardware and supplies needed to complete the installation. Some items may need to be purchased locally. Make sure everything needed to install the product is on hand before starting.

The Indoor equipment mitigation requirements as seen in the table 1, are calculated at sea level. For higher altitudes, adjust the minimum room area specified by the corresponding altitude adjustment factor shown in table 2 below. Table 2 is provided as a reference.

5.1 Serial Plate

The installer must write the maximum possible refrigerant charge and the minimum room area on serial plate. Use table 1 to determine the maximum possible refrigerant charge and minimum (air conditioned) room area based on the total system refrigerant charge. If the installation is not at sea level, refer table 2 to determine how to adjust the minimum (air conditioned) room area. Use a durable marking instrument to write the values on the serial plate.

The installers are responsible for verifying that mitigation procedures are operational with the minimum required mitigation airflow (Refer to table 1 for airflow data).

Adjusted room area ($A_{min\ adj}$) is the product of the minimum air conditioned room and the adjustment factor AF, as shown in the below formula

$$A_{min\ adj} = A_{min} \text{ (Minimum air conditioned room area from table 1)} * AF$$

Height in meters	Height in feet	Altitude Adjustment Factor (AF)
At sea level	At sea level	1.00
1-200	1-660	1.02
200-400	660-1320	1.03
400-600	1320-1970	1.05
600-800	1970-2630	1.07
800-1000	2630-3290	1.09
1000-1200	3290-3940	1.11
1200-1400	3940-4600	1.13
1400-1600	4600-5250	1.15
1600-1800	5250-5910	1.17
1800-2000	5910-6570	1.19
2000-2200	6570-7220	1.21
2200-2400	7220-7880	1.24
2400-2600	7880-8540	1.26
2600-2800	8540-9190	1.29
2800-3000	9190-9850	1.31
3000-3200	9850-10500	1.34

Table 2

NOTE: The altitude adjustment factor (AF) for any altitudes below sea level will be 1.00.



WARNING: FLAMMABLE MATERIALS

WHEN INSTALLED IN A ROOM WITH AN AREA LESS THAN THAT OUTLINED IN TABLE 1, THAT ROOM SHALL BE WITHOUT CONTINUOUSLY OPERATING OPEN FLAMES (FOR EXAMPLE AN OPERATING GAS APPLIANCE) OR OTHER POTENTIAL IGNITION SOURCES (FOR EXAMPLE AN OPERATING ELECTRIC HEAT, HOT SURFACES).

5.2 System Matches



WARNING

PARTIAL UNITS SHALL ONLY BE CONNECTED TO AN APPLIANCE SUITABLE FOR THE SAME REFRIGERANT. THIS UNIT IS A PARTIAL UNIT AIR CONDITIONER, COMPLYING WITH PARTIAL UNIT REQUIREMENTS OF THIS INTERNATIONAL STANDARD, AND MUST ONLY BE CONNECTED TO OTHER UNITS THAT HAVE BEEN CONFIRMED AS COMPLYING TO CORRESPONDING PARTIAL UNIT REQUIREMENTS OF THIS INTERNATIONAL STANDARD.

The entire system (combination of indoor and outdoor sections) must be manufacturer approved and Air-Conditioning, Heating, and Refrigeration Institute (AHRI) listed.

NOTE: Installation of unmatched systems is not permitted. Damage or repairs due to installation of unmatched systems is not covered under the warranty.

5.3 Interconnecting Tubing

Give special consideration to minimize the length of refrigerant tubing when installing cased coils. Refer to outdoor AIR CONDITIONING OR HEAT PUMP INSTALLATION & SERVICE REFERENCE for line set configuration guidelines. If possible, allow adequate length of tubing such that the coil may be removed (for inspection or cleaning services) from the cabinet without disconnecting the tubing.

5.4 Clearances

The unit horizontal clearance from a surface may be 0" from walls and 1" from other units. However, service clearance must take precedence. A minimum of 24" in front of the unit for service clearance is required. Additional clearance on one side or top will be required for electrical wiring connections. Consult all appropriate regulatory codes prior to determining final clearances. In installations that may lead to physical damage (i.e. a garage) it is advised to install a protective barrier to prevent such damage. Always install units such that a positive slope in condensate line (1/4" per foot) is allowed.

Further, any joints made in the installation between parts of the refrigerating system must be accessible for maintenance.

NOTE: Do not pair with any furnace. Refer Accessories Kit guidelines for installation details. Failure to do so may result in property/equipment damage, personal injury or death.

CONSULT ALL APPROPRIATE REGULATORY CODES WHEN DETERMINING FINAL CLEARANCES

5.5 Access

This unit should be installed in a manner so that it is not accessible to the public.

5.6 Horizontal Applications

If installed above a finished living space a secondary drain pan with float switch, as required by many building codes, must be installed under the entire unit and its condensate drain line must be routed to a location such that the user will see the condensate discharge.

6 APPLICATION INFORMATION

NOTE: These Case Coils are designed for indoor installation only at a max altitude of 10,500 feet above sea level or a min altitude of -184 feet below sea level (refer Table 2)

If the unit is in an unconditioned area with high ambient temperature and/or high humidity, the coil may be subject to nuisance sweating of the casing. On these installations, a wrap of 2" fiberglass insulations with a vapor barrier is recommended. Do not cover warning labels and serial plate.



WARNING

AUXILIARY DEVICE WHICH MAY BE A POTENTIAL IGNITION SOURCE ARE NOT TO BE INSTALLED IN THE DUCT WORK. SUCH POTENTIAL IGNITION SOURCES INCLUDE HOT SURFACES WITH A TEMPERATURE EXCEEDING 650°C AND ELECTRIC SWITCHING DEVICES.



WARNING

ONLY AUXILIARY DEVICES APPROVED BY THE APPLIANCE MANUFACTURER OR DECLARED SUITABLE WITH THE REFRIGERANT SHALL BE INSTALLED IN CONNECTING DUCTWORK. IF AN EXISTING DEVICE IS NOT APPROVED BY THE APPLIANCE MANUFACTURER FOR USE WITH THE REFRIGERANT, THE DEVICE MUST BE REMOVED OR DISCONNECTED.

The CCHP Cased Coil and Modular Blower (MBVK) may be installed in one of the Upflow, Downflow, Horizontal Left or horizontal Right orientations as shown in Figures 2, 3 and 4. From the factory, Cased coil is shipped for upflow installation. For any other orientation installation, conversion kits (not shipped with the unit) will be needed as mentioned in Table 1-2, 3, 4, 5 and 6.

For CCHP installations in areas where the return air environment sees humidity levels above 65% relative humidity, a High Humidity Kit (HHK) must be used. See Table 3 for Model and Kit assignment

For horizontal right and left orientations use Horizontal Installation Kit (HIK), refer Table 6

In applications where the air handler is installed in the horizontal left or right position, and the return air environment see humidity levels above 65% relative humidity coupled with total external static levels above 0.9" e.s.p., a Condensate Management Kit (CMK) is available for field application. Kit nomenclature can be found in the Table 4.

Downflow/Horizontal Right Installation

NOTE: In the downflow application, to prevent coil pan “sweating”, the mandatory downflow kit (DFK) is available through your local Daikin distributor. The DFK is not supplied with the air handler and is required to minimize pan sweating on all downflow installations. See Table 5 for the correct DFK and follow the instructions provided for installation.

MAXIMUM ALLOWED CFM				
MODEL	UPFLOW	DOWNFLOW	HORIZONTAL RIGHT	HORIZONTAL LEFT
CAHEA3630C3	1660	1660	1660	1660

Table 1-2

HHK0011
CAHEA3630C3

High Humidity Kit
Table 3

CMK-0017
CAHEA3630C3

Condensate Management Kit
Table 4

DFKE-02
CAHEA3630C3

Downflow Kit
Table 5

HIK001 (0270K00063)
CAHEA3630C3

Horizontal Installation Kit
Table 6

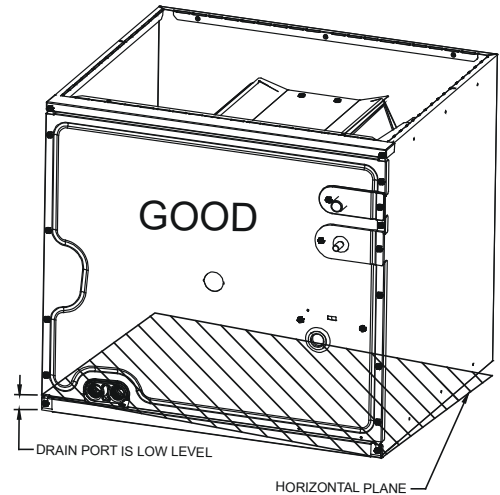
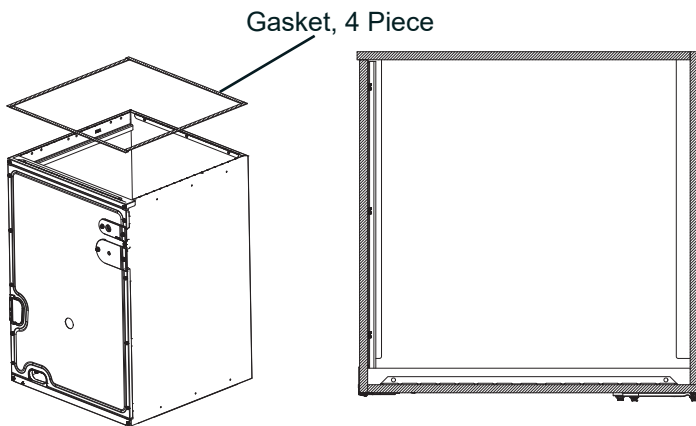

Figure 1

NOTE: For tight sealing on the mating joint between Cased Coil and Modular Blower, gaskets are provided along with the Modular Blower Literature Assy Kits, which need to be installed onto Cased Coil as shown below.



NOTE: The coil must be installed with the line set and drain openings to the front of the modular blower.

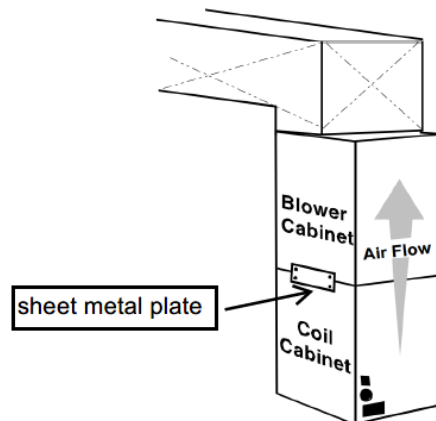

Figure 2 Upflow Application



CAUTION

CHECK HORIZONTALITY LEVEL OF THE UNIT WITH SPIRIT LEVEL. DON'T TILT THE UNIT DOWN THAT MAKES IT DIFFICULT TO DRAIN EVEN THOUGH THE LEVEL IS WITHIN CRITERIA OF SPIRIT LEVEL. SEE FIGURE 1. SUCH TILTED UNITS MAY CAUSE WATER LEAKS.

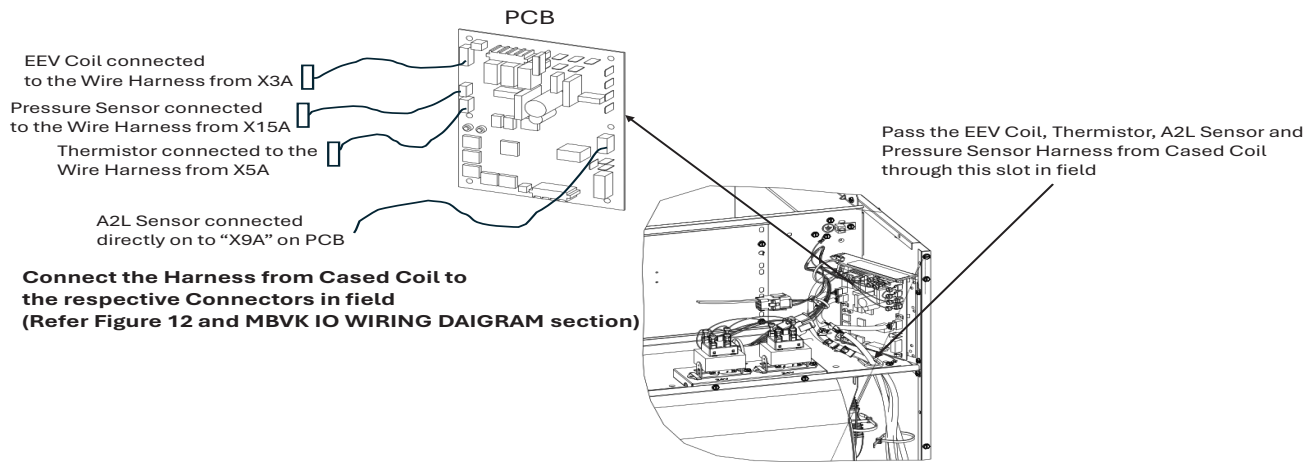

Figure 1A

NOTE: Modular blower is factory shipped with sheet metal plates on both sides. These sheet metal plates shall be used to join cased coil and modular blower with the same screws (refer to figure 2).

Ensure proper seal between the modular blower and cased coil which is critical for proper condensation and to prevent cabinet sweating.

6.1 Upflow Installation

For Up flow installations, the blower cabinet must sit on top of the coil cabinet (Figure 2).

NOTE: All panels should be in place when installing the unit.

1. Place the blower and coil cabinet assembly upright on the return duct or duct opening. Ensure that there is ample support for the cabinet assembly and all attached ductwork.
2. Connect refrigerant and condensate drain connections per the evaporator coil installation instructions. Ensure refrigerant and drain lines do not interfere with service access to the unit.
3. Attach supply ductwork. Seal connections between unit and ductwork as required to reduce / eliminate air leakage.
4. Follow Upflow setup wire Routing as mentioned in the Figure 2-1.

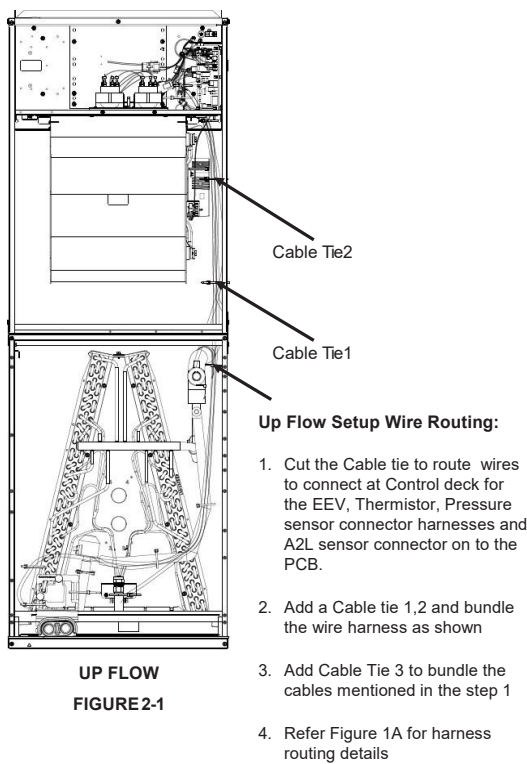

**UP FLOW
FIGURE 2-1**

Figure 2-1

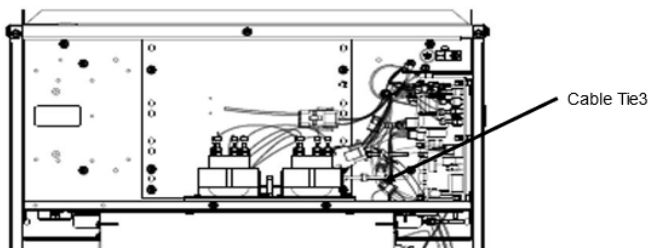
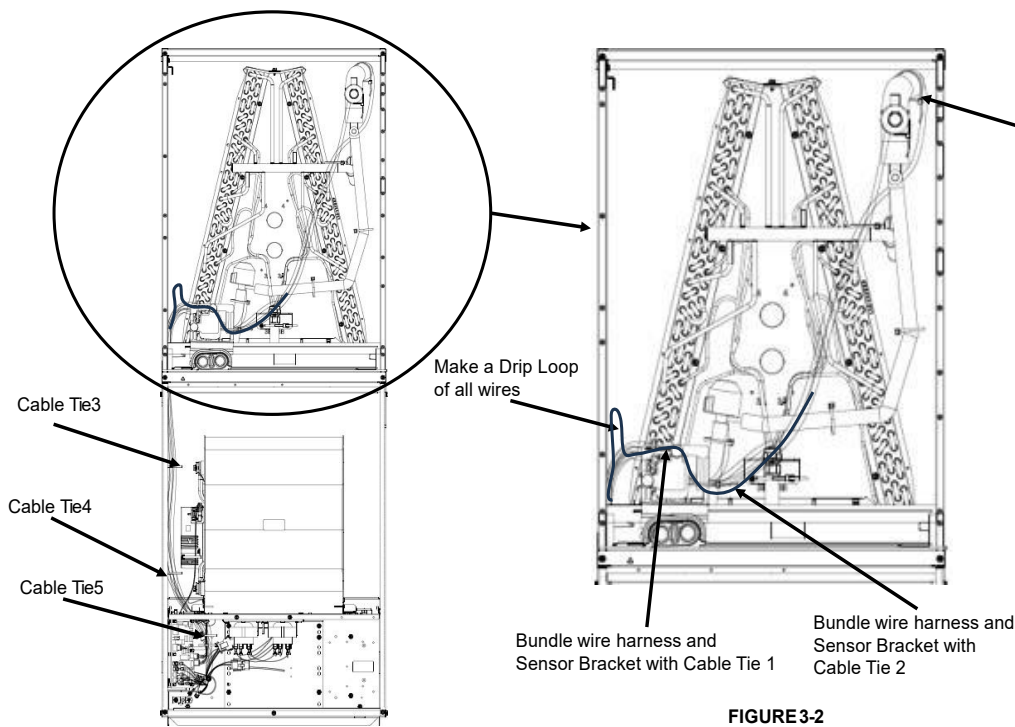

Figure 2-2

6.2 Downflow Installation

For Counterflow installations, the evaporator coil cabinet must sit on top of the blower cabinet (Figure 3). Note: All panels should be in place when installing the unit.

NOTE: For all orientations, cased coil is upstream of modular blower. Return air enters through the cased coil and supply air duct is connected to the modular blower.



DOWNFLOW
FIGURE 3-1

FIGURE 3-2

Down Flow Setup Wire Routing:

1. Cut the Cable ties to route wires to connect at Control deck for the EEV, Thermistor, Pressure sensor connector harnesses and A2L sensor connector on to the PCB.
2. Add a Cable tie 1,2 and create a drip loop of all wires behind the A2L sensor bracket to drip the condensate into the drain pan.
3. Add Cable Tie 3,4 and 5 to bundle the cables mentioned in the step 1
4. Refer Figure 1A for harness routing details

NOTE: Supply ductwork for counterflow applications, must be Class I. However, if combustible ductwork is used, sheet metal protection is required.

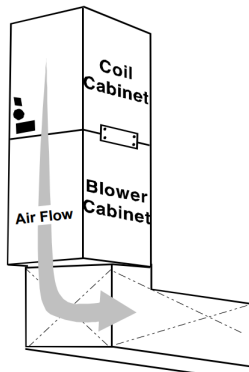

Figure 3 - Counterflow Application

1. Place the blower and coil cabinet assembly supply outlet on the supply duct or duct opening. Ensure that there is ample support for the unit and all attached ductwork.
2. Connect refrigerant and condensate drain connections per the evaporator coil installation instructions. Ensure refrigerant and drain lines do not interfere with service access to the unit.
3. Attach return ductwork. Seal connections between unit and ductwork as required to reduce / eliminate air leakage.
4. Follow Down flow setup wire Routing as mentioned in the Figure 3-1, 3-2, to ensure that condensation water running down from the wire harness is collected in a drain pan.



WARNING

WHEN DOING THE WIRING, MAKE SURE THAT WIRING IS NEAT AND DOES NOT TOUCH SHARP EDGE OF SHEET METAL AND DOES NOT CAUSE THE CONTROL PANEL TO STICK UP, AND THEN CLOSE THE COVER FIRMLY. WHEN ATTACHING THE CONTROL COVER, MAKE SURE YOU DO NOT PINCH ANY WIRES.

6.3 Horizontal Left and Right Installation

NOTE: All panels should be in place when installing the unit.

1. Set the unit near its final installation place. The unit must be supported along the entire length of the unit. Rubber isolation pads may be used to reduce sound and vibration transmission. Ensure there is ample support for the unit and all attached ductwork.

NOTE: Unit must be mounted with access panel facing the front as shown in following diagrams.

For Hanging and Attic Installation, refer to Figure 4 and Figure 5.

2. If installed above a finished ceiling or living space, be sure to put a secondary drain pan under the entire unit, and pipe the drain separately from the main condensate drain.
3. Connect refrigerant and condensate drain connections per the coil section installation instructions. Ensure refrigerant and drain lines do not interfere with service access to the unit.

Horizontal Left Setup Wire Routing:

Note: Refer Horizontal Installation kit instructions for transitioning the unit for horizontal installation

1. Cut the Cable tie to route wires to connect at Control deck for the EEV, Thermistor, Pressure sensor connector harnesses and A2L sensor connector on to the PCB.
2. Move the Sensor Bracket Assy from Main drain pan to Side Drain pan Port as shown in Figure 4-1
3. Add a Cable tie 1,2 and bundle the wire harness as shown
4. Add Cable Tie 3 to bundle the cables mentioned in the step 1
5. Refer Figure 1A for harness routing details

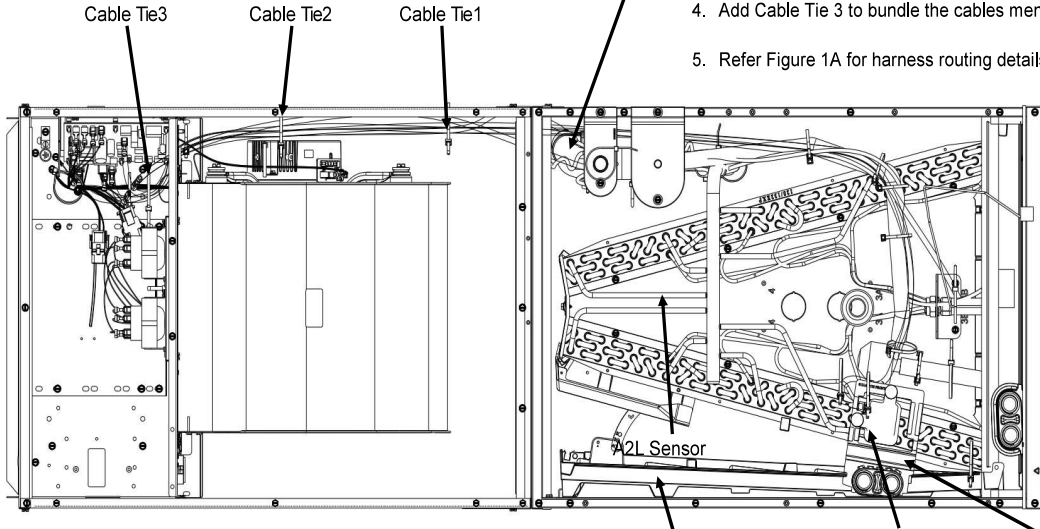

HORIZONTAL LEFT
FIGURE 4-1
 Side DrainPan Refer IO 7036 for installation
 A2L Sensor
 A2L Sensor Bracket Assembly (Move on to Side Drain Pan Ports)

Horizontal Right Setup Wire Routing:

1. Cut the Cable ties to route wires to connect at Control deck for the EEV, Thermistor, Pressure sensor connector harnesses and A2L sensor connector on to the PCB.
2. Move the Sensor Bracket Assy from Main drain pan to Side Drain pan Port as shown in Figure 4-2
3. Add a Cable tie 1 and 2, Make a Drip loop of all the wires and Pass the wires between wrapper and drain pan, route the wires through Cable tie 3 and 4 as shown in the Figure 4-2.
4. Add Cable Tie 5 to bundle the cables mentioned in the step 1
5. Refer Figure 1A for harness routing details

Make a Drip Loop of all wires and add Cable tie 2

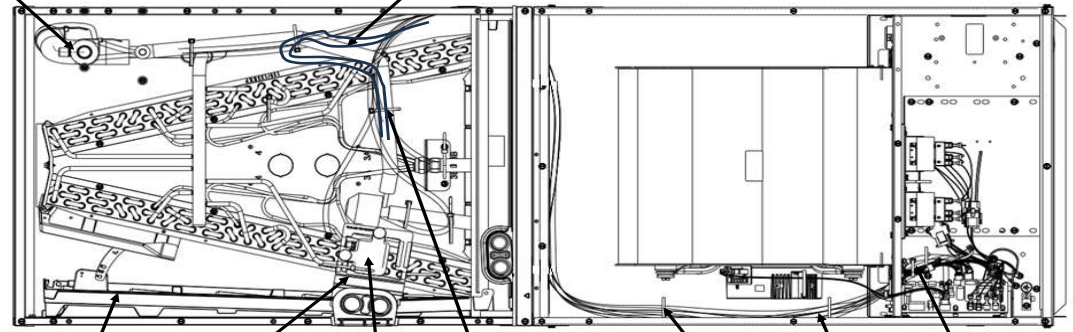

Side DrainPan A2L Sensor A2L Sensor Cable Tie1
 Refer IO 7036 Bracket Assembly (Move on to Side Drain Pan Ports)

Cable Tie3 Cable Tie4 Cable Tie5

HORIZONTAL RIGHT
FIGURE 4-2

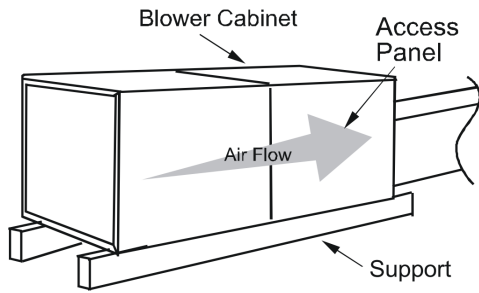

Figure 4 - Attic Installation

NOTE: After installation ensure the correct positioning of the gaskets to prevent air leaks.

4. Attach return and supply ductwork. Seal connections.
5. Follow Horizontal Left and Right setup wire Routing as mentioned in the Figure 4-1, 4-2, to ensure that condensation water running down from wire harness is collected in a drain pan.

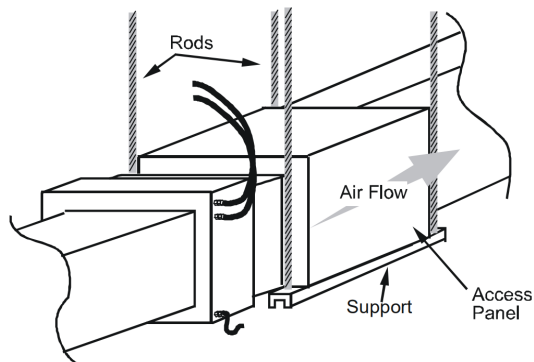

Figure 5 - Hanging Installation

7 DUCTWORK



WARNING

DO NOT OPERATE THIS PRODUCT WITHOUT ALL THE DUCTWORK ATTACHED.

Top flanges can be bent for ease in installation to the duct flanges. (See Figure 6)



WARNING

ALL REQUIRED VENTILATION OPENINGS MUST BE CLEAR OF OBSTRUCTION AND ALL DUCTS CONNECTED TO THE APPLIANCE FREE OF POTENTIAL IGNITION SOURCES.

For appliances using A2L REFRIGERANTS, connected via an air duct system to one or more rooms, the supply and return air shall be directly ducted to the space. The air extraction opening from the room shall be located equal or below the refrigerant release point. For floor mounted units, it shall be as low as practicable. The air extraction openings shall be located in a sufficient distance from the air intake openings to prevent re-circulation to the space.

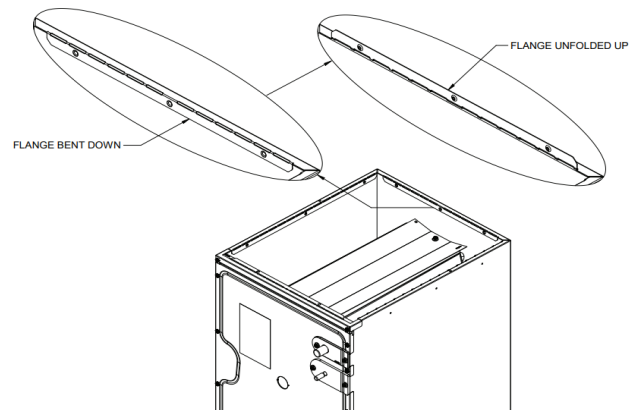

Figure 6

Do not locate the return ductwork in an area that can introduce toxic or objectionable fumes/odors into the ductwork.

8 UV ACCESSORY (OPTIONAL)

The listed Clean Comfort brand UV coil purifier models are the only models approved to be used with this unit. They can be purchased from the distributors. Maximum UV lamp diameter to be used per delta plate knockout design is 1.375" to reduce the possibility of air leak. Installer should apply the UV-C warning label on the maintenance panel when UV-C lamp is installed.

The power source must be installed external of the unit. Ensure that the wiring is routed through the Access Panel knockout with the grommet included. A magnetic door switch must be installed to avoid any accidental ultraviolet exposure during service. The power supply must be installed in parallel with the approve A2L control board utilizing the 24V AUX port to ensure that power to the UV is turned off during mitigation mode. Refer to Modular Blower IOM for A2L Control Board interlocking.

- Ultraviolet radiation hazard symbol IEC 60417-6040.
- Operator's manual symbol ISO 7000-0790.

Refer to UV coil purifiers product specification and installation manual for additional details.

UV-C Part Numbers	
Models	Lamp
UC18S15-24	UCP-16013
UC18S15-24B	UCP-16012



WARNING

- UNINTENDED USE OF APPLIANCES OR DAMAGE TO THE HOUSING MAY RESULT IN THE ESCAPE OF DANGEROUS UV-C RADIATION.
- APPLIANCES THAT ARE OBLIVIOUSLY DAMAGED MUST NOT BE OPERATED.
- UV-C BARRIERS BEARING THE ULTRAVIOLET RADIATION HAZARD SYMBOLS SHOULD NOT BE REMOVED.
- DO NOT OPERATE UV-C LAMPS OUTSIDE OF THE APPLIANCE.

9 REFRIGERANT PIPING WORK



WARNING

THE COIL IS SHIPPED UNDER PRESSURE WITH A DRY NITROGEN MIXTURE. USE APPROPRIATE SERVICE TOOLS AND FOLLOW THESE INSTRUCTIONS TO PREVENT INJURY.



WARNING

A QUENCHING CLOTH IS STRONGLY RECOMMENDED TO PREVENT SCORCHING OR MARRING OF THE EQUIPMENT FINISH WHEN BRAZING CLOSE TO THE PAINTED SURFACES. USE BRAZING ALLOY OF 5% MINIMUM SILVER CONTENT.



WARNING

ONLY BRAZING TECHNIQUES AND APPROVED MECHANICAL JOINTS SHOULD BE USED TO CONNECT REFRIGERANT TUBING CONNECTIONS. NON-APPROVED MECHANICAL CONNECTORS AND OTHER METHODS ARE NOT PERMITTED IN THIS SYSTEM CONTAINING A2L REFRIGERANT. APPROVED MECHANICAL JOINTS WILL BE DETAILED IN THE PRODUCT'S SPECIFICATION SHEETS.



WARNING

WORK SHALL BE UNDERTAKEN UNDER A CONTROLLED PROCEDURE TO MINIMIZE THE RISK OF FLAMMABLE GAS OR VAPOR BEING PRESENT WHILE THE WORK IS BEING PERFORMED.

NOTE: Refrigerant tubing must be routed to allow adequate access for servicing and maintenance of the unit.

Do not handle coil assembly with manifold or flowrator tubes.

Installation of pipe-work must be kept to a minimum. Pipe-work including piping material, pipe routing and installation must be protected from physical damage and shall not be installed in an unventilated space. Equipment piping in an occupied space shall be installed in such a way to protect against accidental damage in operation and service. Precautions must be taken to avoid excess vibration or pulsation to refrigeration piping. Protection devices, piping and fittings shall be protected as far as possible against adverse environmental effects, for example, the danger of water collecting and freezing in relief pipes or the accumulation of dirt and debris. Steel pipes and components shall be protected against corrosion with a rustproof coating before applying any insulation, Any solenoid valves and piping in the refrigerant systems must be so designed and installed to minimize the likelihood of hydraulic shock damaging the system. Solenoid valves must not block in liquid refrigerant unless adequate relief is provided to the refrigerant system's low pressure side. Provisions must be made for expansion and contraction of long runs of piping.

Follow standards related to ASHRAE 15, ASHRAE 15.2, IAPMO Uniform Mechanical Code, ICC International

Mechanical Code or CSA B52 during any installation. Piping must be accessible for inspection prior to being covered or enclosed in compliance with national and local codes.

Flexible pipe elements must be protected against mechanical damage, excessive stress by torsion, or other forces. They should be checked for mechanical damage annually. The indoor equipment and pipes must be securely mounted and guarded such that accidental rupture of equipment cannot occur from such events as moving furniture or reconstruction activities. Field brazed joints indoors shall be tightness tested.

9.1 TUBING SIZE/LENGTH

Give special consideration to minimize the length of refrigerant tubing when installing cased coil. Refer to outdoor unit INSTALLATION & SERVICE REFERENCE for line set configuration guideline. If possible, allow adequate length or tubing such that the coil may be removed (for inspection or cleaning services) from the cabinet without disconnecting the tubing.

9.2 TUBING CONNECTION

1. Remove coil Access Panel and rubber grommets.
2. Remove access valve fitting cap and depress the valve stem in access fitting to release pressure. No pressure indicates possible leak.

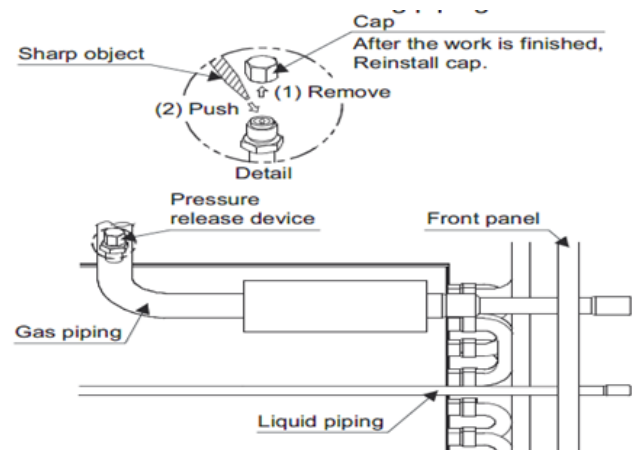

Figure 7

3. Reinstall the Coil ACCESS Panel & rubber grommets.
4. Using a tube cutter, cut off the factory spun end of both the liquid and gas line piping. All cut ends are to be round, burr free and clean. Failure to follow, could increase the chances of refrigerant leak.
5. Insert liquid line set into liquid tube expansion and slide grommet about 18" away from braze joint.
6. Insert suction line set into suction tube expansion and slide insulation and grommet about 18" away from braze joint.
7. Braze suction and liquid line joints.



CAUTION

WHEN BRAZING THE REFRIGERANT PIPING, PERFORM NITROGEN REPLACEMENT FIRST OR PERFORM THE BRAZING WHILE FEEDING NITROGEN INTO THE REFRIGERANT PIPING. SEE FOLLOWING FIGURE. WHEN BRAZING PIPES WHILE FEEDING NITROGEN INSIDE THE PIPING, MAKE SURE TO SET THE NITROGEN PRESSURE TO 2.9 PSI OR LESS USING A PRESSURE REDUCING VALVE.



WARNING

USE OF OXYGEN COULD RESULT IN AN EXPLOSION RESULTING IN SERIOUS INJURY OR DEATH. USE ONLY DRY NITROGEN GAS.

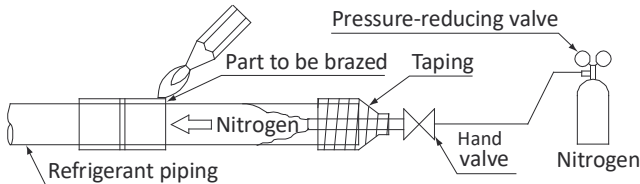

Figure 8



CAUTION

APPLYING TOO MUCH HEAT TO ANY TUBE CAN MELT THE TUBE. TORCH HEAT REQUIRED TO BRAZE TUBES OF VARIOUS SIZES MUST BE PROPORTIONAL TO THE SIZE OF THE TUBE. SERVICE PERSONNEL MUST USE THE APPROPRIATE HEAT LEVEL FOR THE SIZE OF THE TUBE BEING BRAZED.

NOTE: The use of a heat shield is strongly recommended when brazing to avoid burning the serial plate or the finish of the unit. Heat trap or wet rags must be used to protect heat sensitive components such as service valves, electronic expansion valve (EEV), thermistors, A2L sensor, and pressure sensors.

Braze joints should be made only with the connections provided external to the cabinet. Do not alter the cabinet nor braze inside the cabinet. To avoid overheating after brazing, quench all brazed joints with water or a wet rag.

9.3 SYSTEM PRESSURE TESTING



CAUTION

DO NOT OPEN OUTDOOR UNIT LIQUID AND SERVICE VALVE, UNTIL THE INDOOR UNIT AND LINESET IS PRESSURE TESTED AND EVACUATED.

Once all of the refrigerant line connections are completed, perform 3-step nitrogen pressure test as mentioned below. No refrigerant shall be used for pressure testing. Extreme care shall be taken not to over pressurize the system on step 3.

1. Pressurize the system with nitrogen to 150 psig and hold for 3 minutes. If any pressure drops occur, locate and repair leaks and repeat step 1.
2. Pressurize the system with Nitrogen to 325 psig and hold for 5 minutes. If any drops occur, locate and repair leaks and repeat step 1.

3. Pressurize the system with Nitrogen to Maximum Allowable Pressure as listed in the serial plate and hold for 1 hour (4 hours recommended). If any pressure drops occur, locate, and repair leaks and repeat step 1.

If no leaks exist, proceed to system evacuation and charging.

9.4 SYSTEM EVACUATION

For system evacuation follow the below procedure:

1. Connect the vacuum pump with 250 micron capability to the service valves.
2. Evacuate the system to 500 microns or less using suction and liquid service valves. Using both valves are necessary.
3. Close pump valve and hold vacuum for 10 minutes. Typically pressure will rise during this period.
 - If the pressure rises to 500 microns or less and remains steady the system is considered leak-free; proceed to start-up.
 - If pressure rises above 500 microns moisture and /or noncondensibles may be present or the system may have a small leak. Return to step 2: If the same result is encountered check for leaks as previously indicated and repair as necessary then repeat evacuation.

The Triple Evacuation Method is detailed in the Outdoor Installation manual as an alternative

For the system start up and additional refrigerant calculation, refer Outdoor Unit Installation manual .

Field brazed joints indoors shall be tightness tested. The test method shall have a sensitivity of 5 grams per year of refrigerant or better under a pressure of at least 0.25 times the maximum allowable pressure. No leak shall be detected (Should be leak tight).

10 SEALING ALONG THE PANEL GAP

IMPORTANT NOTE: To prevent cabinet "sweating", apply field provided insulation tape along all joining surfaces between the coil, duct work, and panels. See Figure 8.

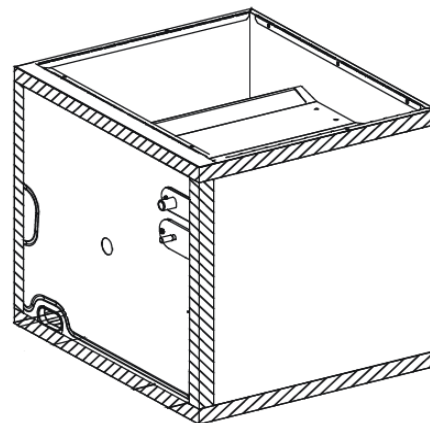

Figure 11

11 DRAIN PIPING WORK

In all cooling applications where condensate overflow may cause damage, a secondary drain pan must be provided by the installer and placed under the entire unit with a separate drain line properly sloped and terminated in an area visible to the owner. This secondary drain pan can provide extra protection to the area under the unit should be the primary drain plug up and overflow. As expressed in our product warranty, we will not be liable for any damages, structural or otherwise due to the failure to follow this installation requirement.

Condensate drain connections are located in the drain pan at the bottom of the coil/enclosure assembly see Figure 12. Use the female ($\frac{3}{4}$ "FPT) threaded fitting that protrudes outside of the enclosure for external connections. The connectors required are $\frac{3}{4}$ " NPT male, either PVC or metal pipe and must be hand tightened to a torque of no more than 37 in-lbs, to prevent damage to the drain pan connection. An insertion depth between .36 to .49 inches (3-5 turns) should be expected at this torque.

1. Ensure drain pan hole is NOT obstructed.
2. To prevent potential sweating and dripping on to finished space, it may be necessary to insulate the condensate drain line located inside the building. Use Armaflex® or similar material.

A secondary condensate drain connection has been provided for areas where the building codes require it. Use a downward slope of at least $\frac{1}{4}$ " per foot to provide free drainage, or as required by local code. Provide required support to the drain line to prevent bowing. If the secondary drain line is required, run the line separately from the primary drain and end it where condensate discharge can be easily seen.

Drain port labeled (A) in Figure 12 is the primary drain and condensate drain line must be attached to this drain port.

Drain port (B) is for the secondary drain line (if used).

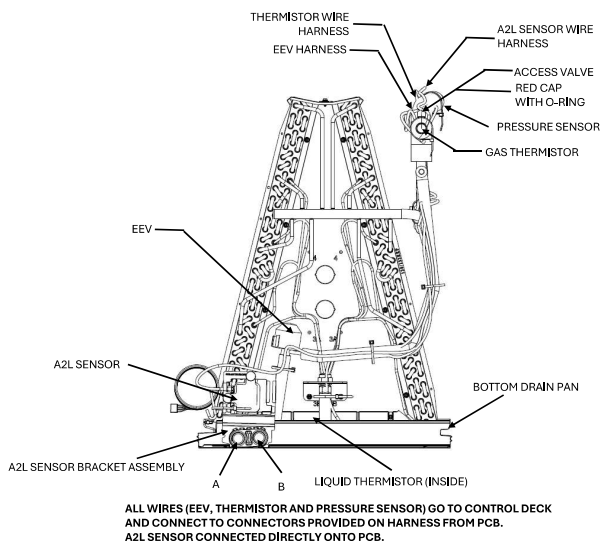

Figure 12

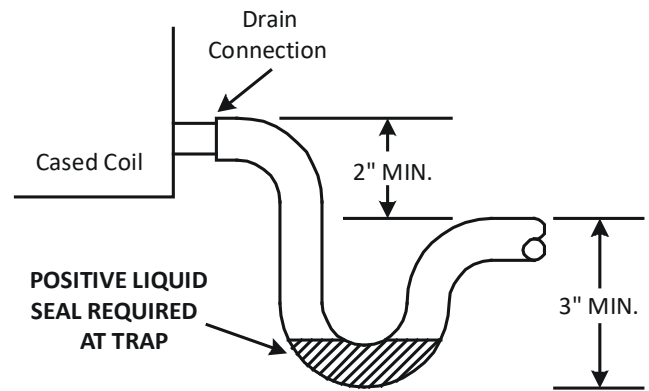

Figure 13



CAUTION

IF A SECONDARY DRAIN IS NOT INSTALLED, THE SECONDARY ACCESS MUST BE PLUGGED.

NOTE:

- Water coming from secondary line means the coil primary drain is plugged and needs immediate attention.
- Insulate drain lines located inside the building or above a finished living space to prevent sweating. The installation must include a "P" style trap that is located as close as is practical to the evaporator coil. See Figure 13 for details of a typical condensate line "P" trap.
- **NOTE:** Units operating in high static pressure applications may require a deeper field constructed "P" style trap than is shown in Figure 13 to allow proper drainage and prevent condensate overflow.
- Trapped lines are required by many local codes. In the absence of any prevailing local codes, please refer to the requirements listed in the uniform mechanical building code.
- A drain trap in a draw-through application prevents air from being drawn back through the drain line during fan operation, thus preventing condensate from draining and if connected to a sewer line, to prevent sewer gases from being drawn into the air stream during blower operation.
- If using copper drain line, solder a short piece of pipe, minimum 6" length, to the connector before installing a drain fitting. DO NOT over torque the $\frac{3}{4}$ " copper connector to the plastic drain connection. Using a wet rag or heatsink material on the short piece to protect the plastic drain pan.



CAUTION

IF A SECONDARY DRAIN IS NOT INSTALLED, THE SECONDARY ACCESS MUST BE PLUGGED.



Condensate drain traps with an open vertical Tee between the cased coil and the condensate drain trap can improve condensate drainage in some applications, but may cause excessive air discharge out of the open Tee. We do not prohibit this type of drain but we also do not recommend it due to the resulting air leakage. Regardless of the condensate drain design used, it is the installer's responsibility to ensure the condensate drain system is of sufficient design to ensure proper condensate removal from the coil drain pan.

Use of a condensate removal pump is permitted when necessary. This condensate pump should have provisions for shutting off the control voltage should a blocked drain occur. See Auxiliary Alarm Switch section that is in modular blower manual for more details. A trap must be installed between the unit and the condensate pump.

NOTE: This cased coil DOES NOT have auxiliary alarm switch feature.

IMPORTANT NOTE: The coil is fabricated with oils that may dissolve Styrofoam® and certain types of plastics. Therefore, the removal pump or float switch must not contain any of these materials.

 WARNING
<p>ALL ACCESSORIES THAT MAY BECOME A POTENTIAL IGNITION SOURCE IF INSTALLED, SUCH AS ELECTRONIC AIR CLEANERS, MUST ONLY BE POWERED THROUGH OUR ACCESSORY CONTROL BOARD KIT. IF AN ELECTRONIC AIR CLEANER IS ALREADY INSTALLED IN THE DUCT WORK AND NOT CONNECTED TO THE ACCESSORY CONTROL BOARD, IT WILL HAVE TO BE DISABLED OR REMOVED. ENSURE THAT ANY ADDITIONAL WIRING FROM THE INDOOR UNIT TO THE ACCESSORY CONTROL BOARD IS ROUTED AND PROTECTED FROM DAMAGE WEAR, AVOIDING ANY JOINTS THAT MAY NEED BRAZED OR DISCONNECTED FOR SERVICE. REFER TO THE PRODUCT SPECIFICATION SHEET FOR THE ACCESSORY CONTROL BOARD KIT PART NUMBER.</p>

 WARNING	
<p>HIGH VOLTAGE DISCONNECT ALL POWER BEFORE SERVICING OR INSTALLING THIS UNIT. MULTIPLE POWER SOURCES MAY BE PRESENT. FAILURE TO DO SO MAY CAUSE PROPERTY DAMAGE, PERSONAL INJURY OR DEATH.</p>	
<p>TO AVOID PROPERTY DAMAGE, PERSONAL INJURY OR DEATH DUE TO ELECTRICAL SHOCK, THIS UNIT MUST HAVE AN UNINTERRUPTED, UNBROKEN ELECTRICAL GROUND. THE ELECTRICAL GROUND CIRCUIT MAY CONSIST OF AN APPROPRIATELY SIZED ELECTRICAL WIRE CONNECT THE GROUND LUG IN THE UNIT CONTROL BOX TO THE BUILDING ELECTRICAL SERVICE PANEL. OTHER METHODS OF GROUND ARE PERMITTED IF PERFORMED IN ACCORDANCE WITH THE NATIONAL ELECTRIC CODE (NEC)/AMERICAN NATIONAL STANDARDS INSTITUTE (ANSI)/ NATIONAL FIRE PROTECTION ASSOCIATION (NFPA) 70 AND LOCAL/STATE CODES. IN CANADA, ELECTRICAL GROUNDING IS TO BE IN ACCORDANCE WITH THE CANADIAN ELECTRIC CODE (CSA C22.1.</p>	

12 A2L SYSTEM SERVICING

This system is charged with R-32 refrigerant. R-32 is classified as A2L (Mildly flammable) as per ASHRAE 34. This product shall be maintained , serviced, decommissioned with the prevailing local /federal codes for A2L refrigerant.

12.1 GUIDELINES

When breaking into the refrigerant circuit to make repairs - or for any other purpose - conventional procedures shall be used. However, the flammability classification for any refrigerant must be considered. The following procedure shall be adhered to:

1. Safely remove refrigerant following local and national regulations;
2. Evacuate;
3. Purge the circuit with inert gas;
4. Evacuate;
5. Continuously flush or purge with inert gas when using flame to open circuit; and
6. Open the circuit.

The minimum test pressure for the low side of the system shall be low side Maximum Allowable Pressure, and the minimum test pressure for the high side of the system shall be high side Maximum Allowable Pressure, unless the high side of the system cannot be isolated from the low side of the system in which case the entire system shall be pressure tested to the low side Maximum Allowable Pressure. Max Allowable Pressure is mentioned in the serial and rating plate. Use dry nitrogen for pressure testing. No refrigerant shall be used for pressure testing to detect leaks.

Field brazed joints indoors shall be tightness tested. The test method shall have a sensitivity of 5 grams per year of refrigerant or better under a pressure of at least 0.25 times the maximum allowable pressure. No leak shall be detected (Should be leak tight).

Under no circumstances shall potential sources of ignition be used in the searching for or detection of refrigerant leaks.

A halide torch (or any other detector using a naked flame) shall not be used. If a leak is suspected, all naked flames shall be removed/extinguished. If a leakage of refrigerant is found which requires brazing, all of the refrigerant shall be recovered from the system, or isolated (by means of shut off valves) in a part of the system remote from the leak.

The following leak detection methods have been deemed acceptable, provided proper care is taken in their implementation:

1. Electronic leak detectors rated for use with R-32 refrigerant. Ensure the detection equipment is calibrated in a refrigerant-free area and that the leak detector itself is not a potential source of ignition. Leak detection equipment shall be set at a value of no more than 0.075 kg/m3.

2. Leak detection fluids - such as the bubble method or fluorescent method. Ensure that the use of detergents containing chlorine are avoided as they chlorine may react with the refrigerant and corrode the pipe-work.

For appliances containing flammable refrigerants, refrigerants purging shall be achieved by breaking the vacuum in the system with oxygen-free nitrogen and continuing to fill until the working pressure is achieved, then venting to atmosphere, and finally pulling down to a vacuum. This process shall be repeated until no refrigerant is within the system. When the final oxygen-free nitrogen charge is used, the system shall be vented down to atmospheric pressure to enable work to take place.

The outlet for the vacuum pump shall not be close to any potential ignition sources, and ventilation shall be available.

12.2 REFRIGERANT RECOVERY

When removing refrigerant from a system, either for servicing or decommissioning, all refrigerants must be removed safely. When transferring refrigerant into cylinders, ensure that only appropriate refrigerant recovery cylinders are employed. Ensure that the correct number of cylinders for holding the total system charge are available. All cylinders to be used are designated for the recovered refrigerant and labeled for that refrigerant (i.e. special cylinders for the recovery of refrigerant). Cylinders shall be complete with pressure-relief valve and associated shut-off valves in good working order. Empty recovery cylinders are evacuated and, if possible, cooled before recovery occurs.

All recovery equipment must be suitable for the recovery of A2L refrigerant and in good working order. Ensure that you follow the manufacturer's instructions carefully. Hoses shall be complete with leak-free disconnect couplings and in good condition. The recovered refrigerant shall be processed according to local legislation in the correct recovery cylinder, and the relevant waste transfer note arranged. Do not mix refrigerants in recovery units and especially not in cylinders.

CASED COIL

CASED COIL HOMEOWNER'S ROUTINE MAINTENANCE RECOMMENDATIONS

We strongly recommend a bi-annual maintenance checkup be performed before the heating and cooling seasons begin by a **qualified servicer**.

REPLACE OR CLEAN FILTER

IMPORTANT NOTE: Never operate unit without a filter installed as dust and lint will build up on internal parts resulting in loss of efficiency, equipment damage and possible fire.

An indoor air filter must be used with your comfort system. A properly maintained filter will keep the indoor coil of your comfort system clean. A dirty coil could cause poor operation and/or severe equipment damage.



Your air filter or filters could be located in your furnace, in a blower unit, or in "filter grilles" in your ceiling or walls. The installer of your air conditioner or heat pump can tell you where your filter(s) are, and how to clean or replace them.

Check your filter(s) at least once a month. When they are dirty, replace or clean as required. Disposable type filters should be replaced. Reusable type filters may be cleaned.

You may want to ask your dealer about high efficiency filters. High efficiency filters are available in both electronic and non-electronic types. These filters can do a better job of catching small airborne particles.

MOTORS

Indoor and outdoor fan motors are permanently lubricated and do not require additional oiling.

 WARNING	
HIGH VOLTAGE DISCONNECT ALL POWER BEFORE SERVICING OR INSTALLING THIS UNIT. MULTIPLE POWER SOURCES MAY BE PRESENT. FAILURE TO DO SO MAY CAUSE PROPERTY DAMAGE, PERSONAL INJURY OR DEATH.	

ALUMINUM INDOOR COIL CLEANING (QUALIFIED SERVICER ONLY)

R-32 sensor must be removed from the unit before applying coil cleaners to avoid damage and contamination. Reassemble the R-32 sensor back in the unit after completing the coil cleaning process. This unit is equipped with an aluminum tube evaporator coil. The safest way to clean the evaporator coil is to simply flush the coil with water. This cleaning practice remains as the recommended cleaning method for both copper tube and aluminum tube residential evaporator coils.

It has been determined that many coil cleaners and drain pan tablets contain corrosive chemicals that can be harmful to aluminum tube and fin evaporator coils. Even a one-time application of these corrosive chemicals can cause premature aluminum evaporator coil failure. Any cleaners that contain corrosive chemicals including, but not limited to, chlorine and hydroxides, should not be used. An alternate cleaning method is to use one of the products listed in TP-

109* to clean the coils. The cleaners listed are the only agents deemed safe and approved for use to clean round tube aluminum coils.

 WARNING
DO NOT USE MEANS TO ACCELERATE THE DEFROSTING PROCESS OR TO CLEAN, OTHER THAN THOSE RECOMMENDED BY THE MANUFACTURER. THE APPLIANCE SHALL BE STORED IN A ROOM WITHOUT CONTINUOUSLY OPERATING IGNITION SOURCES (FOR EXAMPLE: OPEN FLAMES, AN OPERATING GAS APPLIANCE OR AN OPERATING ELECTRIC HEATER). DO NOT PIERCE OR BURN. BE AWARE THAT REFRIGERANTS MAY NOT CONTAIN AN ODOR.

TP-109 is also available on the web site in Partner Link > Service Toolkit.

NOTE: Ensure coils are rinsed well after use of any chemical cleaners.

- Condensate line must be trapped and pitched to allow for drainage.
- Low voltage wiring is properly connected.
- Auxilliary drain is installed when necessary and pitched to allow for drainage.
- Unit is protected from vehicular or other physical damage.
- Return air is not obtained from, nor are there any return air duct joints that are unsealed in, areas where there may be objectionable odors, flammable vapors or products of combustion such as carbon monoxide (CO), which may cause serious personal injury or death.
- Ensure that the equipped R-32 sensor is wired to the PCB and that there are no sources of potential ignition within the system.

 CAUTION
TO AVOID THE RISK OF EQUIPMENT DAMAGE OR FIRE, INSTALL THE SAME AMPERAGE BREAKER OR FUSE AS YOU ARE REPLACING. IF THE CIRCUIT BREAKER OR FUSE SHOULD OPEN AGAIN WITHIN THIRTY DAYS, CONTACT A QUALIFIED SERVICER TO CORRECT THE PROBLEM. IF YOU REPEATEDLY RESET THE BREAKER OR REPLACE THE FUSE WITHOUT HAVING THE PROBLEM CORRECTED, YOU RUN THE RISK OF SEVERE EQUIPMENT DAMAGE.

BEFORE YOU CALL YOUR SERVICER

- Check the thermostat to confirm that it is properly set.
- Wait 15 minutes. Some devices in the outdoor unit or in programmable thermostats will prevent compressor operation for awhile, and then reset automatically. Also, some power companies will install devices which shut off air conditioners for several minutes on hot days. If you wait several minutes, the unit may begin operation on its own.
- Check the electrical panel for tripped circuit breakers or open fuses. Reset the circuit breakers or replace fuses as necessary.
- Check the disconnect switch near the indoor furnace or blower to confirm that it is closed.
- Check for obstructions on the outdoor unit. Confirm that it has not been covered on the sides or the top. Remove any obstruction that can be safely removed. If the unit is covered with dirt or debris, call a qualified servicer to clean it.
- Check for blockage of the indoor air inlets and outlets. Confirm that they are open and have not been blocked by objects (rugs, curtains or furniture).
- Check the filter. If it is dirty, clean or replace it.
- Listen for any unusual noise(s), other than normal operating noise, that might be coming from the outdoor unit. If you hear unusual noise(s) coming from the unit, call a qualified servicer.

START-UP CHECKLIST

Air Handler / Coil				
	Model Number			
	Serial Number			
ELECTRICAL				
Line Voltage (Measure L1 and L2 Voltage)	L1 - L2			
Secondary Voltage (Measure Transformer Output Voltage)	R - C			
Blower Amps				
Heat Strip 1 - Amps				
Heat Strip 2 - Amps				
BLOWER EXTERNAL STATIC PRESSURE				
Return Air Static Pressure			IN. W.C.	
Supply Air Static Pressure			IN. W.C.	
Total External Static Pressure (Ignoring +/- from the reading above, add total here)			IN. W.C.	
TEMPERATURES				
Return Air Temperature (Dry bulb / Wet bulb)		DB °F		WB °F
Cooling Supply Air Temperature (Dry bulb / Wet bulb)		DB °F		WB °F
Heating Supply Air Temperature		DB °F		
Temperature Rise		DB °F		
Delta T (Difference between Supply and Return Temperatures)		DB °F		
Air Handler / Coil - (Inverter Matched)				
INVERTER AH / COIL ONLY				
Check EEV and EEV wiring is secure (no adjustment required)				
Additional Checks				
Check wire routings for any rubbing				
Check product for proper draining				
Check screw tightness on blower wheel				
Check factory wiring and wire connections				
Check product for proper clearances as noted by installation instructions				
Check R-32 sensor wiring & wire connections to the Modular Blower PCB				
Check that mitigation mode is operational				
°F to °C formula: (°F - 32) divided by 1.8 = °C °C to °F formula: (°C multiplied by 1.8) + 32 = °F				

CUSTOMER FEEDBACK

We are very interested in all product comments.

Please fill out the feedback form on one of the following links:

Daikin Products: (<https://daikincomfort.com/contact-us>)

Goodman® Brand Products: (<http://www.goodmanmfg.com/about/contact-us>).

Amana® Brand Products: (<http://www.amana-hac.com/about-us/contact-us>).

You can also scan the QR code on the right for the product brand you purchased to be directed to the feedback page.



DAIKIN



GOODMAN® BRAND



AMANA® BRAND

NOTE: SPECIFICATIONS AND PERFORMANCE DATA LISTED HEREIN ARE SUBJECT TO CHANGE WITHOUT NOTICE

Quality Makes the Difference!

All of our systems are designed and manufactured with the same high quality standards regardless of size or efficiency. We have designed these units to significantly reduce the most frequent causes of product failure. They are simple to service and forgiving to operate. We use quality materials and components. Finally, every unit is run tested before it leaves the factory.

That's why we know. . . **There's No Better Quality.**

Our continuing commitment to quality products may mean a change in specifications without notice.

© 2025 - 2026 Daikin Comfort Technologies Manufacturing, Inc.

19001 Kermier Rd., Waller, TX 77484

www.daikincomfort.com • www.goodmanmfg.com • www.amana-hac.com

Amana is a registered trademark of Maytag Corporation or its related companies and is used under license. All rights reserved.