

# MBVK\*\*\*POX00

## BLOWER CABINET

### INSTALLATION INSTRUCTIONS

© 2025-2026

Daikin Comfort Technologies Manufacturing, Inc.

19001 Kermier Rd., Waller, TX 77484

www.daikincomfort.com - www.goodmanmfg.com - www.amana-hac.com

P/N: IO-465A Date: February 2026



#### WARNING

ONLY PERSONNEL THAT HAVE BEEN TRAINED TO INSTALL, ADJUST, SERVICE, MAINTENANCE OR REPAIR (HEREINAFTER, "SERVICE") THE EQUIPMENT SPECIFIED IN THIS MANUAL SHOULD SERVICE THE EQUIPMENT.

THIS EQUIPMENT IS NOT INTENDED FOR USE BY PERSONS (INCLUDING CHILDREN) WITH REDUCED PHYSICAL, SENSORY OR MENTAL CAPABILITIES, OR LACK OF EXPERIENCE AND KNOWLEDGE, UNLESS THEY HAVE BEEN GIVEN SUPERVISION OR INSTRUCTION CONCERNING USE OF THE APPLIANCE BY A PERSON RESPONSIBLE FOR THEIR SAFETY.

CHILDREN SHOULD BE SUPERVISED TO ENSURE THAT THEY DO NOT PLAY WITH THE EQUIPMENT.

THE MANUFACTURER WILL NOT BE RESPONSIBLE FOR ANY INJURY OR PROPERTY DAMAGE ARISING FROM IMPROPER SUPERVISION, SERVICE OR SERVICE PROCEDURES. IF YOU SERVICE THIS UNIT, YOU ASSUME RESPONSIBILITY FOR ANY INJURY OR PROPERTY DAMAGE WHICH MAY RESULT. IN ADDITION, IN JURISDICTIONS THAT REQUIRE ONE OR MORE LICENSES TO SERVICE THE EQUIPMENT SPECIFIED IN THIS MANUAL, ONLY LICENSED PERSONNEL SHOULD SERVICE THE EQUIPMENT. IMPROPER SUPERVISION, INSTALLATION, ADJUSTMENT, SERVICING, MAINTENANCE OR REPAIR OF THE EQUIPMENT SPECIFIED IN THIS MANUAL, OR ATTEMPTING TO INSTALL, ADJUST, SERVICE OR REPAIR THE EQUIPMENT SPECIFIED IN THIS MANUAL WITHOUT PROPER SUPERVISION OR TRAINING MAY RESULT IN PRODUCT DAMAGE, PROPERTY DAMAGE, PERSONAL INJURY OR DEATH.



#### WARNING

DO NOT BYPASS SAFETY DEVICES.



#### WARNING

DO NOT INSTALL ELECTRIC HEATER KIT ON THIS UNIT.

**QUEBEC DISCLOSURE REGARDING AVAILABILITY OF REPLACEMENT PARTS, REPAIR SERVICES AND INFORMATION FOR MAINTENANCE AND REPAIR: DAIKIN COMFORT TECHNOLOGIES MANUFACTURING, INC. (DAIKIN) DOES NOT GUARANTEE THE AVAILABILITY OF (1) REPLACEMENT PARTS; (2) REPAIR SERVICES; AND (3) INFORMATION NECESSARY TO MAINTAIN OR REPAIR PRODUCTS, WITHIN THE MEANING OF SECTION 39.1 OF THE CONSUMER PROTECTION ACT, CQLR, c P-40.1 AND SECTION 79.18 OF THE REGULATION RESPECTING THE APPLICATION OF THE CONSUMER PROTECTION ACT, CQLR, c P-40.1, R. 3.**

**AVIS POUR LE QUÉBEC CONCERNANT LA DISPONIBILITÉ DES PIÈCES DE RECHANGE, DES SERVICES DE RÉPARATION ET DES RENSEIGNEMENTS POUR L'ENTRETIEN ET LA RÉPARATION : DAIKIN COMFORT TECHNOLOGIES MANUFACTURING, INC. (DAIKIN) NE GARANTIT PAS LA DISPONIBILITÉ (1) DES PIÈCES DE RECHANGE, (2) DES SERVICES DE RÉPARATION ET (3) DES RENSEIGNEMENTS POUR L'ENTRETIEN ET LA RÉPARATION, AU SENS DE L'ARTICLE 39.1 DE LA LOI SUR LA PROTECTION DU CONSOMMATEUR, RLRQ c P-40.1 ET DE L'ARTICLE 79.18 DU RÈGLEMENT D'APPLICATION DE LA LOI SUR LA PROTECTION DU CONSOMMATEUR, RLRQ c P-40.1, R 3.**

#### CONTENTS

INTRODUCTION.....	2
ELECTROSTATIC DISCHARGE (ESD) PRECAUTIONS .....	2
CHECKING PRODUCT RECEIVED.....	2
REPLACEMENT PARTS.....	2
ORDERING PARTS .....	2
IMPORTANT SAFETY INSTRUCTIONS .....	2
RECOGNIZE SAFETY SYMBOLS, WORDS, AND LABELS .....	2
GENERAL INFORMATION .....	3
FEATURES.....	3
ACHIEVING LESS AIR LEAKAGE.....	3
CLEARANCES AND ACCESSIBILITY .....	3
INSULATION .....	3
INSTALLATION INSTRUCTIONS .....	4
BLOWER WITH CASED EVAPORATOR COIL INSTALLATION.....	4
UPFLOW INSTALLATION .....	4
COUNTERFLOW INSTALLATION .....	4
HORIZONTAL INSTALLATION .....	4
COUNTERFLOW AND HORIZONTAL APPLICATIONS .....	5
ELECTRICAL CONNECTIONS.....	5
115 VOLT LINE CONNECTIONS .....	5
LOW VOLTAGE WIRING.....	5
AUXILIARY ALARM SWITCH .....	6
CIRCULATOR BLOWER.....	6
TROUBLESHOOTING .....	7
ELECTROSTATIC DISCHARGE (ESD) PRECAUTIONS.....	7
DIAGNOSTIC CHART .....	7
FAULT RECALL .....	7
COMFORTNET™ SYSTEM.....	7
AIRFLOW CONSIDERATION .....	7
CONTROL WIRING.....	8
COMFORTNET™ SYSTEM ADVANCE FEATURES .....	8
MODULAR BLOWER ADVANCED FEATURES MENU .....	9



is a registered trademark of Maytag Corporation or its related companies and is used under license. All rights reserved.



**DIAGNOSTICS ..... 10**  
**NETWORK TROUBLESHOOTING..... 10**  
**SYSTEM TROUBLESHOOTING ..... 10**  
**TROUBLESHOOTING INFORMATION..... 11**  
**WIRING DIAGRAM..... 16**  
**HOMEOWNERS ROUTINE MAINTENANCE RECOMMENDATIONS .... 17**  
**START UP CHECKLIST ..... 18**

THIS PRODUCT CONTAINS ELECTRONIC COMPONENTS WHICH REQUIRE A DEFINITE GROUND. PROVISIONS ARE MADE FOR CONNECTION OF THE GROUND. A DEDICATED GROUND FROM THE MAIN POWER SUPPLY OR AN EARTH GROUND MUST BE PROVIDED.

**INTRODUCTION**

This booklet contains the installation and operating instructions for your modular blower cabinet. All warnings and precautions within this booklet must be observed. Improper installation can result in problems ranging from noisy operation to property or equipment damages, dangerous conditions that could result in injury or personal property damage and that are not covered by the warranty. Read this booklet and any instructions packaged with accessories prior to installation. Give this booklet to the user and explain its provisions. The user should retain this booklet for future reference.

**NOTE:** To use with R-32 (A2L) systems, “NON-A2L furnace Integration kit” is a must (Not shipped with this product). Please refer to the installation instructions supplied with the kit for the details of kit installation.

**ELECTROSTATIC DISCHARGE (ESD) PRECAUTIONS**

**NOTE:** Discharge body’s static electricity before touching unit. An electrostatic discharge can adversely affect electrical components.

Use the following precautions during modular blower installation and servicing to protect the integrated control module from damage. By putting the modular blower, the control, and the person at the same electrostatic potential, these steps will help avoid exposing the integrated control module to electrostatic discharge. This procedure is applicable to both installed and uninstalled (ungrounded) blowers.

1. Disconnect all power to the blower. Do not touch the integrated control module or any wire connected to the control prior to discharging your body’s electrostatic charge to ground.
2. Firmly touch a clean, unpainted, metal surface of the modular blower near the control. Any tools held in a person’s hand during grounding will be discharged.
3. Service integrated control module or connecting wiring following the discharge process in step 2. Use caution not to recharge your body with static electricity; (i.e., do not move or shuffle your feet, do not touch ungrounded objects, etc.). If you come in contact with an ungrounded object, repeat step 2 before touching control or wires.
4. Discharge your body to ground before removing a new control from its container. Follow steps 1 through 3 if installing the control on a blower. Return any old or new controls to their containers before touching any ungrounded object.

**CHECKING PRODUCT RECEIVED**

Upon receiving the unit, inspect it for damage from shipment. Claims for damage, either shipping or concealed, should be filed immediately with the shipping company. Check the unit model number, specifications, electrical characteristics and accessories to determine if they are correct. In the event an incorrect unit is shipped, it must be returned to the supplier and must NOT be installed. The manufacturer assumes no responsibility for installation of incorrectly shipped units.

**REPLACEMENT PARTS**

**ORDERING PARTS**

When reporting shortages or damages, or ordering repair parts, give the complete unit model and serial numbers as stamped on the unit’s nameplate.

Replacement parts for this appliance are available through your contractor or local distributor. For the location of your nearest distributor contact:

HOMEOWNER SUPPORT  
 DAIKIN COMFORT TECHNOLOGIES MANUFACTURING, INC.  
 19001 KERMIER ROAD  
 WALLER, TEXAS 77484  
 (877) 254-4729

**IMPORTANT SAFETY INSTRUCTIONS**

**RECOGNIZE SAFETY SYMBOLS, WORDS, AND LABELS**

The following symbols and labels are used throughout this manual to indicate immediate or potential hazards. It is the owner’s responsibility to read and comply with all safety information and instructions accompanying these symbols. Failure to heed safety information increases the risk of property damage, product damage, personal injury or death.



**WARNING**

**HIGH VOLTAGE!**  
**DISCONNECT ALL POWER BEFORE SERVICING.**  
**MULTIPLE POWER SOURCES MAY BE PRESENT. FAILURE TO DO SO MAY CAUSE PROPERTY DAMAGE, PERSONAL INJURY OR DEATH.**



**ACCESS**

This unit should be installed in a manner so that it is not accessible to the public.

 <b>DANGER</b> <b>PELIGRO</b>

<b>CARBON MONOXIDE POISONING HAZARD</b>
<b>Special Warning for Installation of Furnace or Air Handling Units in Enclosed Areas such as Garages, Utility Rooms or Parking Areas</b>
<p>Carbon monoxide producing devices (such as an automobile, space heater, gas water heater, etc.) should not be operated in enclosed areas such as unventilated garages, utility rooms or parking areas because of the danger of carbon monoxide (CO) poisoning resulting from the exhaust emissions. If a furnace or air handler is installed in an enclosed area such as a garage, utility room or parking area and a carbon monoxide producing device is operated therein, there must be adequate, direct outside ventilation.</p> <p>This ventilation is necessary to avoid the danger of CO poisoning which can occur if a carbon monoxide producing device continues to operate in the enclosed area. Carbon monoxide emissions can be (re)circulated throughout the structure if the furnace or air handler is operating in any mode.</p>
<p>CO can cause serious illness including permanent brain damage or death. <span style="float: right;">B10259-216</span></p>
<b>RIESGO DE INTOXICACIÓN POR MONÓXIDO DE CARBONO</b>
<p>Advertencia especial para la instalación de calentadores ó manejadoras de aire en áreas cerradas como estacionamientos ó cuartos de servicio.</p> <p>Los equipos ó aparatos que producen monóxido de carbono (tal como automóvil, calentador de gas, calentador de agua por medio de gas, etc) no deben ser operados en áreas cerradas debido al riesgo de envenenamiento por monóxido de carbono (CO) que resulta de las emisiones de gases de combustión. Si el equipo ó aparato se opera en dichas áreas, debe existir una adecuada ventilación directa al exterior.</p> <p>Esta ventilación es necesaria para evitar el peligro de envenenamiento por CO, que puede ocurrir si un dispositivo que produce monóxido de carbono sigue operando en el lugar cerrado.</p> <p>Las emisiones de monóxido de carbono pueden circular a través del aparato cuando se opera en cualquier modo.</p>
<p>El monóxido de carbono puede causar enfermedades severas como daño cerebral permanente ó muerte. <span style="float: right;">B10259-216</span></p>
<b>RISQUE D'EMPOISONNEMENT AU MONOXYDE DE CARBONE</b>
<p>Avertissement special au sujet de l'installation d'appareils de chauffage ou de traitement d'air dans des endroits clos, tels les garages, les locaux d'entretien et les stationnements.</p> <p>Évitez de mettre en marche les appareils produisant du monoxyde de carbone (tels que les automobile, les appareils de chauffage autonome, etc.) dans des endroits non ventilés tels que les d'empoisonnement au monoxyde de carbone. Si vous devez faire fonctionner ces appareils dans un endroit clos, assurez-vous qu'il y ait une ventilation directe provenant de l'exterieur.</p> <p>Cette ventilation est nécessaire pour éviter le danger d'intoxication au CO pouvant survenir si un appareil produisant du monoxyde de carbone continue de fonctionner au sein de la zone confinée.</p> <p>Les émissions de monoxyde de carbone peuvent être recirculées dans les endroits clos, si l'appareil de chauffage ou de traitement d'air sont en marche.</p>
<p>Le monoxyde de carbone peut causer des maladies graves telles que des dommages permanents au cerveau et même la mort. <span style="float: right;">B10259-216</span></p>

## GENERAL INFORMATION

The MBVK Blower Cabinets are used in combination with a cased evaporator coil. This combination of blower and coil functions as the indoor part of a split air-conditioning system, and may be matched with a remote condensing or heat pump unit.

Systems should be properly sized by heat gain and loss calculations made according to methods of the Air Conditioning Contractors Association (ACCA) or equivalent. It is the contractor's responsibility to ensure the system has adequate capacity to heat or cool the conditioned space.

## FEATURES

This modular blower is a part of the ComfortNet™ family of products. It may be installed as part of a "legacy" system using a standard 24 VAC thermostat or, with a ComfortNet™ thermostat kit, as part of a digitally communicating system. The ComfortNet™ system simplifies wiring, provides enhanced setup features and elevates diagnostics capabilities.

## ACHIEVING LESS AIR LEAKAGE:

Ensure all the gaskets remain intact on surfaces as shipped with the unit. Ensure upon installation that the plastic breaker cover is flush on with the access panel and access panel is flush with the cabinet. With these requirements satisfied, the unit achieves less airflow leakage when tested in accordance with ASHRE Standard 193.

- Cabinet air leakage less than 2.0% at 1.0 inch H<sub>2</sub>O when tested in accordance with ASHRAE standard 193.
- Cabinet air leakage less than 1.4% at 0.5 inch H<sub>2</sub>O when tested in accordance with ASHRAE standard 193.

## CLEARANCES AND ACCESSIBILITY

The unit can be positioned for upflow, counterflow, horizontal right or horizontal left operation. Zero clearance is allowed on all sides for combustible materials. Thirty-six inches should be allotted on the door side for maintenance and service.

To reduce risk of rusting, do not install the unit directly on the ground or on a floor that is likely to be wet. In such environments, the unit must be elevated by use of a sturdy, nonporous material.

**NOTE:** This unit should be installed in a manner so that it is not accessible to the public.

## INSULATION

To ensure efficient operation, review the following precautions.

- If the unit is located in an area with high ambient temperature and/or high humidity, the air handler may be subject to nuisance sweating of the casing. On these installations, a wrap of 2" fiberglass insulation with a vapor barrier is recommended.
- The factory recommends insulating the duct running through any unconditioned spaces.

To reduce operating sound and vibration transmission use flexible canvas duct connections at the cabinet.

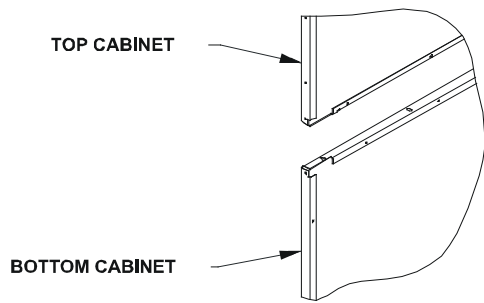

Figure 1 - Coil and Blower Connection

## INSTALLATION INSTRUCTIONS

**NOTE:** This appliance is designed for indoor installation only at max. altitude of 10,500 feet above sea level & a min altitude of -184 feet below sea level.

### BLOWER WITH CASED EVAPORATOR COIL INSTALLATION

Secure the coil and blower together with the two connector plates and screws supplied in the blower bag assembly. Use one connector plate and six screws on each side of the unit.

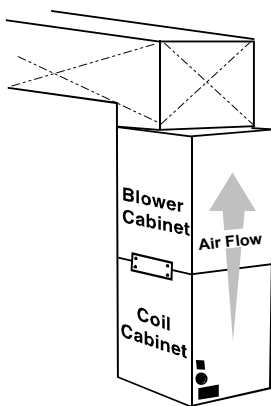

Figure 2 - Upflow Application

### UPFLOW INSTALLATION

For upflow installations, the blower cabinet must sit on top of the coil cabinet (Figure 2).

**NOTE:** All panels should be in place before installing the cabinet.

1. Place the blower and coil cabinet assembly upright on the return duct or duct opening. Ensure that there is ample support for the cabinet assembly and all attached ductwork.
2. Connect refrigerant and condensate drain connections per the evaporator coil installation instructions. Ensure refrigerant and drain lines do not interfere with service access to the unit.
3. Attach supply ductwork. Seal connections between unit and ductwork as required to reduce/eliminate air leakage.
4. Make electrical connections as specified in *Electrical Connections* section of this manual.

### COUNTERFLOW INSTALLATION

For counterflow installations, the evaporator coil cabinet must sit on top of the blower cabinet (Figure 3). **NOTE:** All panels should be in place when installing the unit.

**NOTE:** Supply ductwork for counterflow applications, must be Class I. However, if combustible ductwork is used, sheet metal protection is required.

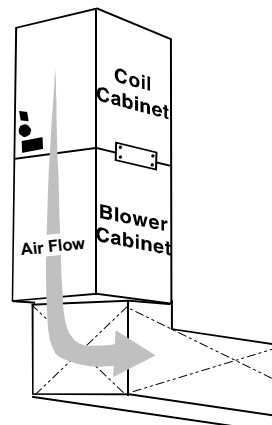

Figure 3 - Counterflow Application

1. Place the blower and coil cabinet assembly supply outlet on the supply duct or duct opening. Ensure there is ample support for the unit and all attached ductwork.
2. Connect refrigerant and condensate drain connections per the evaporator coil installation instructions. Ensure refrigerant and drain lines do not interfere with service access to the unit.
3. Attach return ductwork. Seal connections between unit and ductwork as required to reduce/eliminate air leakage.
4. Make electrical connections as specified in *Electrical Connections* section of this manual.

### HORIZONTAL INSTALLATION

For horizontal installations, the coil cabinet must be upstream of the blower cabinet (Figures 4 and 5). **NOTE:** All panels should be in place when installing the unit.

1. Set the unit near its final installation place. The unit must be supported along the entire length of the unit. Rubber isolation pads may be used to reduce sound and vibration transmission. Ensure there is ample support for the unit and all attached ductwork.

**NOTE:** Unit must be mounted with access panel facing the front as shown in following diagrams.

2. If installed above a finished ceiling or living space, be sure to put a secondary drain pan under the entire unit, and pipe the drain separately from the main condensate drain.
3. Connect refrigerant and condensate drain connections per the coil section installation instructions. Ensure refrigerant and drain lines do not interfere with service access to the unit.

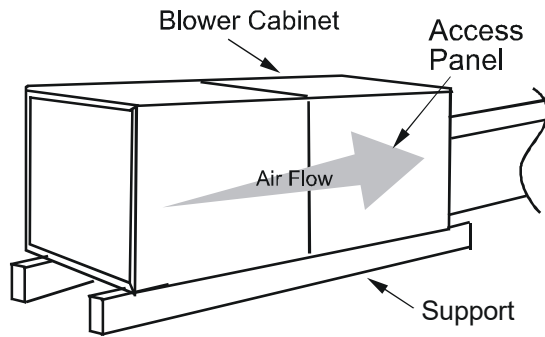

Figure 4 - Attic Installation

4. Attach return and supply ductwork. Seal connections.
5. Make electrical connections as specified in *Electrical Connections* section of this manual.

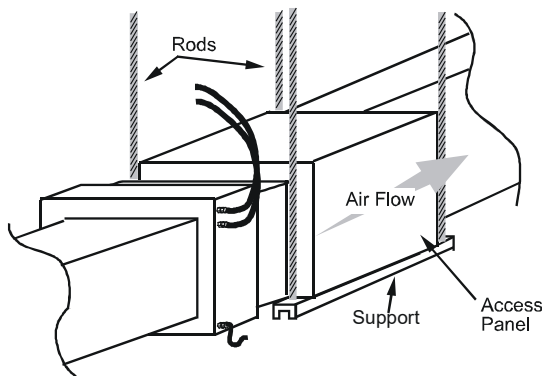

Figure 5 - Hanging Installation

### COUNTERFLOW AND HORIZONTAL APPLICATIONS

Loosen motor mount and rotate motor (See Figure 6). Be sure motor is oriented with the female connections on the casing pointing down. If the motor is not oriented with the connections pointing down, water could collect in the motor and cause premature failure.

**NOTE:** After rotating motor, tighten motor mount to secure motor. Be sure that the gap between the motor and the insulation is the same as it was before loosening the motor mount. This will ensure that the blower wheel is properly spaced inside the blower housing.

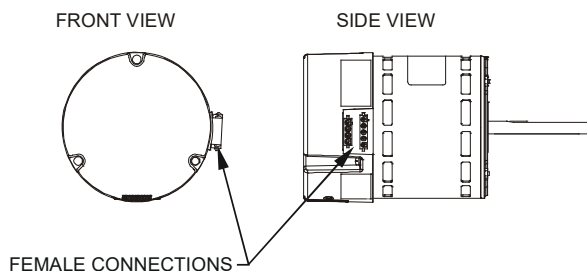

Figure 6 - MBVK Motor Orientation

## ELECTRICAL CONNECTIONS

If this modular blower is matched up with a cased coil from the CAPEA or CHPEA product families, the cased coil PCB must be supplied with 24VAC from an appropriately powered transformer. A transformer has been included with the cased coil. Refer to the cased coil installation & operation instruction manual regarding transformer parts and installation. A Disconnect should be incorporated in the field wiring in accordance with wiring codes. Consult the local power company and local codes before installing this unit. All wiring must be in accordance with the National Electrical Code as well as all local codes. Knockouts have been provided on side and top of the cabinet for the installation of the electrical conduit. If the knockouts on the cabinet sides are used for electrical conduit, an adapter ring must be used in order to meet UL60335-2-40 safety requirements. Use Minimum Circuit Ampacity and type of wire to determine proper wire size. The unit **MUST** be properly grounded. A ground lug is provided in the unit.

Check all factory connections before connecting electrical power to unit to ensure none were loosened or disconnected during shipping and handling.

This unit is designed for single-phase electrical supply only. **DO NOT OPERATE MODULAR BLOWER ON A THREE PHASE POWER SUPPLY.** Measure the power supply to the unit. The supply voltage must be measured and be in agreement with the unit nameplate power requirements and within the range shown below table.

Rated Voltage	Minimum Voltage	Maximum Voltage
115 VAC	103	126

Electrical Voltage



### 115 VOLT LINE CONNECTIONS

Remove the proper size knockout for the electrical conduit connection. Connect electrical conduit to the unit using two washers to make an approved connection. If the high voltage knockout is removed, please use the provided foam tape to seal the opening with the conduit.

The power supply wires must be connected to the white and black power wiring. Two wire nuts are provided in the bag assembly for this connection. Wrap the wire nuts with electrical tape. (Insulated crimp type connectors, field supplied, may be substituted for the wire nuts and electrical tape provided proper size connectors are used.) A ground wire **MUST** be connected to the ground lug inside the unit.

### LOW VOLTAGE WIRING

A 24V-control voltage connects the air handler to the room thermostat and condenser and must use low voltage wiring with copper conductors. A minimum 18 AWG wire must be used for installations up to 150 feet. Low voltage wiring must be connected through the top of the cabinet or either side. See the "Thermostat Wiring" section of this manual for typical low voltage wiring connections. If the low voltage opening is being used, please replace the pre-installed cap with the bushing provided in the literature kit.

 <b>WARNING</b>
<b>HIGH VOLTAGE</b> TO PREVENT PERSONAL INJURY OR DEATH DUE TO ELECTRICAL SHOCK, DISCONNECT THE ELECTRICAL POWER BEFORE ELECTRICALLY CONNECTING THE UNIT. 

 <b>WARNING</b>
TO AVOID THE RISK OF FIRE OR EQUIPMENT DAMAGE, USE COPPER CONDUCTORS.

 <b>CAUTION</b>
TO AVOID THE RISK OF PERSONAL INJURY , WIRING TO THE UNIT MUST BE PROPERLY POLARIZED AND GROUNDED.

 <b>WARNING</b>
INSTALLATION MUST COMPLY WITH APPLICABLE LOCAL AND NATIONAL CODES. TYPE AND LOCATION OF FUSED DISCONNECT SWITCH(ES) MUST COMPLY WITH ALL APPLICABLE CODES AND PROVIDE OVERCURRENT PROTECTION AS SHOWN ON THE NAMEPLATE.

 <b>WARNING</b>
ELECTRIC HEATER KITS CANNOT BE USED ON THESE MODULAR BLOWERS. ENSURE "HEATER KIT INSTALLED OPTION" IS UNCHECKED ON COMMUNICATING THERMOSTAT AND DEFROST HEAT IS SELECTED WITH NO BACK UP HEAT FOR APPLICABLE HEAT PUMPS. THIS IS TO PREVENT INDOOR MOTOR FROM RUNNING WHICH WILL RESULT IN BLOWING OFF THE COLD AIR DURING THE DEFROST CYCLE AND WHEN THE AMBIENT TEMPERATURE DROP BELOW LOCKOUT TEMPERATURE OF HEAT PUMP.

**AUXILIARY ALARM SWITCH**

The control is equipped with two Auxiliary Alarm terminals labeled CAS which can be utilized with communicating mode setups (typically used for condensate switch wiring but could be used with compatible CO2 sensors or fire alarms).

Communication mode use

This feature can be activated or deactivated through the thermostat user menus. An auxiliary alarm switch must be normally closed and open when the base pan's water level in the evaporator coil reaches a particular level. The control will respond by turning off the outdoor compressor and display the proper fault codes. If the switch is detected closed for 30 seconds, normal operation resumes and the error message will be removed.

**CIRCULATOR BLOWER**

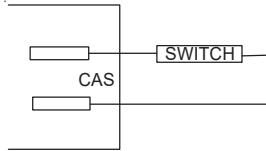

Figure 7 - Auxiliary Alarm Switch

This modular blower is equipped with a variable speed circulator blower. This blower provides ease in adjusting blower speeds.

## TROUBLESHOOTING

### DIAGNOSTIC CHART

Refer to the Troubleshooting Chart at the end of this manual for assistance in determining the source of unit operational problems. The 7 segment LED display will provide any active fault codes. An arrow printed next to the display indicates proper orientation (arrow points to top of display). See following image.



Figure 8 - Diagnostic Display

### FAULT RECALL

The integrated control module is equipped with a momentary pushbutton switch that can be used to display the last six faults on the 7 segment LED display. The control must be in Standby Mode (no thermostat inputs) to use the feature. Depress the push-button for approximately two seconds and less than five seconds. The LED display will then display the six most recent faults beginning with the most recent fault and decrementing to the least recent fault. The faults may be cleared by depressing the button for greater than five seconds.

**NOTE:** Consecutively repeated faults are displayed a maximum of three times.

## COMFORTNET™ SYSTEM

### OVERVIEW

The ComfortNet™ system (or CT™ system) is a system that includes a ComfortNet™ compatible modular blower and air conditioner or heat pump with a compatible communicating thermostat. (see Electrical Connections - 24 Volt Thermostat Wiring for wiring connections).

A ComfortNet™ heating/air conditioning system differs from a legacy/traditional system in the manner in which the indoor unit, outdoor unit and thermostat interact with one another. In a traditional system, the thermostat sends commands to the indoor and outdoor units via analog 24 VAC signals. It is a one-way communication path in that the indoor and outdoor units typically do not return information to the thermostat. In a ComfortNet™ system, the indoor unit, outdoor unit, and thermostat “communicate” digitally with one another creating a two-way communications path. The thermostat sends commands to the indoor and outdoor units, and also requests and receives information from both the indoor and outdoor units.

Two-way digital communications is accomplished using only two wires. The thermostat and subsystem controls are powered with 24 VAC. Thus, a maximum of 4 wires between the equipment and thermostat is all that is required to operate the system.

### AIRFLOW CONSIDERATION

Airflow demands are managed differently in a fully communicating system than they are in a legacy wired system. The system operating mode (as determined by the thermostat) determines which unit calculates the system airflow demand. If the indoor unit is responsible for determining the airflow demand, it calculates the demand and sends it to the ECM motor. If the outdoor unit or thermostat is responsible for determining the demand, it calculates the demand and transmits the demand along with a fan request to the indoor unit. The indoor unit then sends the demand to the ECM motor. Figure 9 lists the various ComfortNet™ systems, the operating mode, and airflow demand source.

System	System Operating Mode	Airflow Demand Source
Air Conditioner + Air Handler	Cooling	Air Conditioner
	Continuous Fan	Thermostat
Heat Pump + Air Handler	Cooling	Heat Pump
	Heat Pump Heating Only	Heat Pump
	Continuous Fan	Thermostat

Figure 9 - Airflow Demands

For example, assume the system is a heat pump matched with an air handler. With a call for low stage cooling, the heat pump will calculate the system's low stage cooling airflow demand. The heat pump will then send a fan request along with the low stage cooling airflow demand to the air handler. Once received, the air handler will send the low stage cooling airflow demand to the ECM motor. The ECM motor then delivers the low stage cooling air-flow. See the applicable ComfortNet™ air conditioner or heat pump installation manual for the airflow delivered during cooling or heat pump heating.

In continuous fan mode, the compatible communicating thermostat provides the air-flow demand. The thermostat may be configured for a low, medium, or high continuous fan speed. The low, medium, and high fan speeds correspond to 25%, 60%, and 100%, respectively, of the air handlers' maximum airflow capability. During continuous fan operation, the thermostat sends a fan request along with the continuous fan demand to the air handler. The air handler, in turn, sends the demand to the ECM motor. The ECM motor delivers the requested continuous fan airflow. medium, or high continuous fan speed. The low, medium, and high fan speeds correspond to 25%, 60%, and 100%, respectively, of the air handlers' maximum airflow capability. During continuous fan operation, the thermostat sends a fan request along with the continuous fan demand to the air handler. The air handler, in turn, sends the demand to the ECM motor. The ECM motor delivers the requested continuous fan airflow.

## CONTROL WIRING

**NOTE:** A removable plug connector is provided with the control to make thermostat wire connections. This plug may be removed, wire connections made to the plug, and replaced. It is **STRONGLY** recommended that you do not connect multiple wires into a single terminal. Wire nuts are recommended to ensure one wire is used for each terminal.

Typical 18 AWG thermostat wire may be used to wire the system components. Typical wiring will consist of two wires between the indoor unit and outdoor unit and four wires between the indoor unit and thermostat. Figure 10 shows the required wires are data lines, 1 and 2; "R" (24 VAC hot) and "C" (24 VAC common).

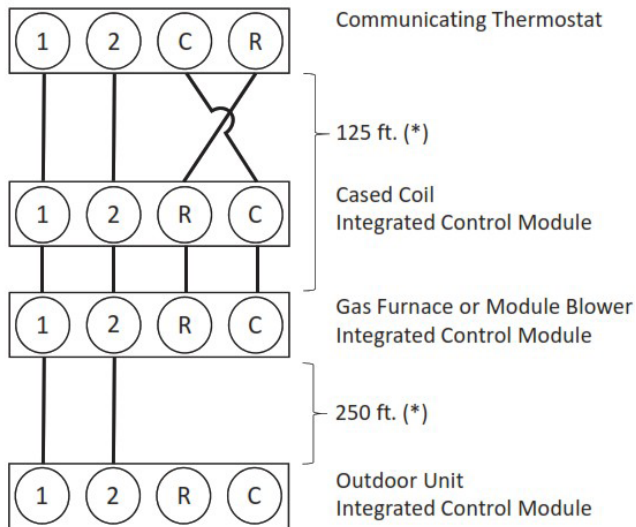

Figure 10 - System Wiring

## COMFORTNET™ SYSTEM ADVANCE FEATURES

The ComfortNet™ system permits access to additional system information, advanced setup features, and advanced diagnostic/troubleshooting features. These advanced features are organized into a menu structure. See the following MODULAR BLOWER ADVANCED FEATURES MENUS section for layout of menu shortcuts.

## MODULAR BLOWER ADVANCED FEATURES MENU

DIAGNOSTICS		
Submenu Item	Indication/User Modifiable Options	Comments
Fault 1 (FAULT #1)	Most recent fault	For display only
Fault 2 (FAULT #2)	Next most recent fault	For display only
Fault 3 (FAULT #3)	Next most recent fault	For display only
Fault 4 (FAULT #4)	Next most recent fault	For display only
Fault 5 (FAULT #5)	Next most recent fault	For display only
Fault 6 (FAULT #6)	Least recent fault	For display only
Clear Fault History (CLEAR)	NO or YES	Selecting "YES" clears the fault history

**NOTE:** Consecutively repeated faults are shown a maximum of 3 times

IDENTIFICATION	
Submenu Item	Indication (for Display Only; not User Modifiable)
Model Number (MOD NUM)	Displays the modular blower model number
Serial Number (SER NUM)	Displays the modular blower serial number (Optional)
Software (SOFTWARE)	Displays the application software revision

SET-UP		
Submenu Item	User Modifiable Options	Comments
Heat Airflow Trim (HT TRM)	-10% to +10% in 2% increments, default is 0%	Trims the heating airflow by the selected amount.
Auxiliary Alarm	ON / OFF	Enable or disable Auxiliary Alarm input

STATUS	
Submenu Item	Indication (for Display Only; not User Modifiable)
Mode (MODE)	Displays the current modular blower operating mode
CFM (CFM)	Displays the airflow for the current operating mode

## DIAGNOSTICS

Accessing the modular blower’s diagnostics menu provides ready access to the last six faults detected by the modular blower. Faults are stored most recent to least recent. Any consecutively repeated fault is stored a maximum of three times. Example: A clogged return air filter causes the modular blower’s motor to repeatedly enter a limiting condition. The control will only store this fault the first three consecutive times the fault occurs.

**NOTE:** It is highly recommended that the fault history be cleared when performing maintenance or servicing the modular blower.

## NETWORK TROUBLESHOOTING

The ComfortNet™ system is a fully communicating system, and thus, constitutes a network. Occasionally the need to troubleshoot the network may arise. The integrated control has some on-board tools that may be used to troubleshoot the network.

These tools are: red communications LED, green receive (Rx) LED, and LEARN button.

- Red communications LED – Indicates the status of the network. The table below indicates the LED status and the corresponding potential problem.
- Green receive LED – Indicates network traffic. The table below indicates the LED status and the corresponding potential problem.
- Learn button – Used to reset the network. Depress the button for approximately 2 seconds to reset the network.

## SYSTEM TROUBLESHOOTING

**NOTE:** Refer to the instructions accompanying the CT™ compatible outdoor AC/HP unit for troubleshooting information.

Refer to the Troubleshooting Chart in the Appendix for a listing of possible modular blower error codes, possible causes and corrective actions.

## Communications Status LED's

LED	LED Status	Indication	Possible Causes	Corrective Action(s)	Notes & Cautions
Red Communications LED	Off	<ul style="list-style-type: none"> <li>• Normal condition</li> </ul>	<ul style="list-style-type: none"> <li>• None</li> </ul>	<ul style="list-style-type: none"> <li>• None</li> </ul>	<ul style="list-style-type: none"> <li>• None</li> </ul>
	1 Flash	<ul style="list-style-type: none"> <li>• Communications Failure</li> </ul>	<ul style="list-style-type: none"> <li>• Communications Failure</li> </ul>	<ul style="list-style-type: none"> <li>• Depress Learn Button</li> <li>• Verify that bus BIAS and TERM dipswitches are in the ON position.</li> </ul>	<ul style="list-style-type: none"> <li>• Depress once quickly for a power-up reset</li> <li>• Depress and hold for 2 seconds for an out-of-box reset</li> </ul>
	2 Flashes	<ul style="list-style-type: none"> <li>• Out-of-box reset</li> </ul>	<ul style="list-style-type: none"> <li>• Control power up</li> <li>• Learn button depressed</li> </ul>	<ul style="list-style-type: none"> <li>• None</li> </ul>	<ul style="list-style-type: none"> <li>• None</li> </ul>
Green Receive LED	Off	<ul style="list-style-type: none"> <li>• No power</li> <li>• Communications error</li> </ul>	<ul style="list-style-type: none"> <li>• No power to modular blower</li> <li>• Open fuse</li> <li>• Communications error</li> </ul>	<ul style="list-style-type: none"> <li>• Check fuses and circuit breakers; replace/reset</li> <li>• Replace blown fuse</li> <li>• Check for shorts in low voltage wiring in modular blower/system</li> <li>• Reset network by depressing learn button</li> <li>• Check data 1/ data 2 voltages</li> </ul>	<ul style="list-style-type: none"> <li>• Turn power OFF prior to repair.</li> <li>• See Network Troubleshooting section.</li> </ul>
	1 Steady Flash	<ul style="list-style-type: none"> <li>• No network found</li> </ul>	<ul style="list-style-type: none"> <li>• Broken/ disconnected data wire(s)</li> <li>• Modular blower is installed as a legacy/ traditional system</li> </ul>	<ul style="list-style-type: none"> <li>• Check communications wiring (data 1/ data 2 wires)</li> <li>• Check wire connections at terminal block</li> <li>• Verify modular blower installation type (legacy/ traditional or communicating)</li> <li>• Check data 1/ data 2 voltages</li> </ul>	<ul style="list-style-type: none"> <li>• Turn power OFF prior to repair</li> <li>• Verify wires at terminal blocks are securely twisted together prior to inserting into terminal block</li> <li>• See Network Troubleshooting section</li> </ul>
	Rapid Flashing	<ul style="list-style-type: none"> <li>• Normal network traffic</li> </ul>	<ul style="list-style-type: none"> <li>• Control is “talking” on network as expected</li> </ul>	<ul style="list-style-type: none"> <li>• None</li> </ul>	<ul style="list-style-type: none"> <li>• None</li> </ul>
	On Solid	<ul style="list-style-type: none"> <li>• Data 1/ Data 2 miss-wire</li> </ul>	<ul style="list-style-type: none"> <li>• Data 1 and data 2 wires reversed at modular blower, thermostat, or CT™ compatible outdoor AC/HP</li> <li>• Short between data 1 and data 2 wires</li> <li>• Short between data 1 or data 2 wires and R (24VAC) or C (24VAC common)</li> </ul>	<ul style="list-style-type: none"> <li>• Check communications wiring (data 1/ data 2 wires)</li> <li>• Check wire connections at terminal block</li> <li>• Check data 1/ data 2 voltages</li> </ul>	<ul style="list-style-type: none"> <li>• Turn power OFF prior to repair</li> <li>• Verify wires at terminal blocks are securely twisted together prior to inserting into terminal block</li> <li>• See Network Troubleshooting section</li> </ul>

## TROUBLESHOOTING INFORMATION: AIR HANDLER DIAGNOSTIC CODES

Symptoms of Abnormal Operation (Legacy & ComfortNet™ Thermostat)	7-Segment LED Codes	Fault Description	ComfortNet™ Thermostat Only		Possible Causes	Corrective Actions	Notes & Cautions
			Message	Code			
<ul style="list-style-type: none"> <li>LED display is ON continuously</li> <li>Integrated control module LED display EF error code.</li> <li>ComfortNet™ thermostat "Call for Service".</li> </ul>	ON EF	<ul style="list-style-type: none"> <li>Normal operation</li> <li>Aux switch open</li> </ul>	None	None	<ul style="list-style-type: none"> <li>Normal operation</li> <li>High water level in the evaporation coil.</li> </ul>	<ul style="list-style-type: none"> <li>None</li> <li>Check overflow pan and service</li> </ul>	<ul style="list-style-type: none"> <li>Normal operation</li> <li>Turn power OFF prior to service.</li> </ul>

# TROUBLESHOOTING INFORMATION: AIR HANDLER DIAGNOSTIC CODES

Symptoms of Abnormal Operation (Legacy & ComfortNet™ Thermostat)	7-Segment LED Codes	Fault Description	ComfortNet™ Thermostat Only		Possible Causes	Corrective Actions	Notes & Cautions
			Message	Code			
<ul style="list-style-type: none"> <li>Modular blower fails to operate</li> <li>Integrated control module LED display provides no signal.</li> <li>ComfortNet™ thermostat "Call for Service" icon illuminated</li> <li>ComfortNet™ thermostat scrolls "Check Air Handler" message</li> </ul>		<ul style="list-style-type: none"> <li>No 115 volt power to modular blower or no 24 volt power to integrated control module</li> <li>Blown fuse or circuit breaker</li> <li>Integrated control module has an internal fault.</li> </ul>	INTERNAL FAULT	EE	<ul style="list-style-type: none"> <li>Manual disconnect switch OFF or 24 volt wire improperly connected or loose</li> <li>Blown fuse or circuit breaker</li> <li>Integrated control module has an internal fault</li> </ul>	<ul style="list-style-type: none"> <li>Assure 115 volt and 24 volt power to modular blower and integrated control module.</li> <li>Check integrated control module fuse (3A). Replace if necessary.</li> <li>Check for possible shorts in 115 volt and 24 volt circuits. Repair as necessary.</li> <li>Replace bad integrated control module.</li> </ul>	<ul style="list-style-type: none"> <li>Turn power OFF prior to repair.</li> <li>Replace integrated control module fuse with 3A automotive fuse.</li> <li>Replace integrated control module with correct replacement part</li> <li>Read precautions in "Electrostatic Discharge" section of manual.</li> </ul>
<ul style="list-style-type: none"> <li>Modular blower fails to operate.</li> <li>Integrated control module LED display provides indicated error code</li> <li>ComfortNet™ thermostat "Call for Service" icon illuminated.</li> <li>ComfortNet™ thermostat scrolls "Check Air Handler" message.</li> </ul>	d0	<ul style="list-style-type: none"> <li>Data not yet on network.</li> </ul>	NO NET DATA	d0	<ul style="list-style-type: none"> <li>Modular blower does not contain any shared data.</li> </ul>	<ul style="list-style-type: none"> <li>Populate shared data set using memory card.</li> </ul>	<ul style="list-style-type: none"> <li>Turn power OFF prior to repair</li> <li>Use memory card for the specific model.</li> <li>Insert memory card BEFORE turning power ON. Memory card may be removed after data is loaded.</li> <li>Error code will be cleared once data is loaded.</li> <li>Turn power off before removing memory card</li> </ul>
<ul style="list-style-type: none"> <li>Modular blower fails to operate.</li> <li>Integrated control module LED display provides indicated error code.</li> <li>ComfortNet™ thermostat "Call for Service" icon illuminated.</li> <li>ComfortNet™ thermostat scrolls "Check Air Handler" message.</li> </ul>	d1	<ul style="list-style-type: none"> <li>Invalid data on network.</li> </ul>	INVALID DATA	d1	<ul style="list-style-type: none"> <li>Modular blower does not contain an appropriate shared data set.</li> </ul>	<ul style="list-style-type: none"> <li>Populate correct shared data set using memory card.</li> </ul>	<ul style="list-style-type: none"> <li>Turn power OFF prior to repair</li> <li>Use memory card for the specific model.</li> <li>Insert memory card BEFORE turning power ON. Memory card may be removed after data is loaded.</li> <li>Error code will be cleared once data is loaded.</li> </ul>
<ul style="list-style-type: none"> <li>Operation different than expected or no operation.</li> <li>Integrated control module LED display provides indicated error code.</li> <li>ComfortNet™ thermostat "Call for Service" icon illuminated.</li> <li>ComfortNet™ thermostat scrolls "Check Air Handler" message.</li> </ul>	d4	<ul style="list-style-type: none"> <li>Invalid memory card data.</li> </ul>	INVALID MC DATA	d4	<ul style="list-style-type: none"> <li>Shared data set on memory card has been rejected by integrated control module</li> </ul>	<ul style="list-style-type: none"> <li>Verify shared data set is correct for the specific model. Re-populate data using correct memory card if required.</li> </ul>	<ul style="list-style-type: none"> <li>Turn power OFF prior to repair</li> <li>Use memory card for the specific model.</li> <li>Insert memory card BEFORE turning power ON. Memory card may be removed after data is loaded.</li> <li>Error code will be cleared once data is loaded.</li> <li>Turn power off before removing memory card</li> </ul>

# TROUBLESHOOTING INFORMATION: AIR HANDLER DIAGNOSTIC CODES

Symptoms of Abnormal Operation (Legacy & ComfortNet™ Thermostat)	7-Segment LED Codes	Fault Description	ComfortNet™ Thermostat Only		Possible Causes	Corrective Actions	Notes & Cautions
			Message	Code			
<ul style="list-style-type: none"> <li>Modular blower fails to operate.</li> <li>Integrated control module LED display provides indicated error code.</li> <li>ComfortNet™ thermostat "Call for Service" icon illuminated.</li> <li>ComfortNet™ thermostat scrolls "Check Air Handler" message.</li> </ul>	b0	<ul style="list-style-type: none"> <li>Circulator blower motor is not running when it should be running.</li> </ul>	MOTOR NOT RUN	b0	<ul style="list-style-type: none"> <li>Loose wiring connection at circulator motor power leads or circulator motor power leads disconnected.</li> <li>Failed circulator blower motor.</li> </ul>	<ul style="list-style-type: none"> <li>Tighten or correct wiring connection.</li> <li>Check circulator blower motor. Replace if necessary.</li> </ul>	<ul style="list-style-type: none"> <li>Turn power OFF prior to repair</li> <li>Replace circulator motor with correct replacement part.</li> </ul>
<ul style="list-style-type: none"> <li>Modular blower fails to operate.</li> <li>Integrated control module LED display provides indicated error code.</li> <li>ComfortNet™ thermostat "Call for Service" icon illuminated.</li> <li>ComfortNet™ thermostat scrolls "Check Air Handler" message.</li> </ul>	b1	<ul style="list-style-type: none"> <li>Integrated control module has lost communications with circulator blower motor.</li> </ul>	MOTOR COMM	b1	<ul style="list-style-type: none"> <li>Loose wiring connection at circulator motor control leads.</li> <li>Failed circulator blower motor.</li> <li>Failed integrated control module.</li> </ul>	<ul style="list-style-type: none"> <li>Tighten or correct wiring connection.</li> <li>Check circulator blower motor. Replace if necessary.</li> <li>Check integrated control module. Replace if necessary.</li> </ul>	<ul style="list-style-type: none"> <li>Turn power OFF prior to repair</li> <li>Replace circulator motor with correct replacement part.</li> <li>Replace integrated control module with correct replacement part.</li> </ul>
<ul style="list-style-type: none"> <li>Modular blower fails to operate.</li> <li>Integrated control module LED display provides indicated error code.</li> <li>ComfortNet™ thermostat "Call for Service" icon illuminated.</li> <li>ComfortNet™ thermostat scrolls "Check Air Handler" message.</li> </ul>	b2	<ul style="list-style-type: none"> <li>Circulator blower motor horse power in shared data set does not match circulator blower motor horse power.</li> </ul>	MOTOR MISMATCH	b2	<ul style="list-style-type: none"> <li>Incorrect circulator blower motor in modular blower.</li> <li>Incorrect shared data set in integrated control module.</li> </ul>	<ul style="list-style-type: none"> <li>Verify circulator blower motor horse power is the same specified for the specific modular blower model. Replace is necessary.</li> <li>Verify shared data set is correct for the specific model. Re-populate data using correct memory card if required.</li> </ul>	<ul style="list-style-type: none"> <li>Turn power OFF prior to repair</li> <li>Replace motor with correct replacement part.</li> <li>Use memory card for the specific model</li> <li>Insert memory card BEFORE turning power ON. Memory card may be removed after data is loaded.</li> <li>Error code will be cleared once shared data and motor horse power match.</li> <li>Turn power off before removing memory card</li> </ul>
<ul style="list-style-type: none"> <li>Modular blower operates at reduced performance.</li> <li>Airflow delivered is less than expected.</li> <li>Integrated control module LED display provides b3 error code.</li> </ul>	b3	<ul style="list-style-type: none"> <li>Circulator blower motor is operating in a power, temperature, or speed limiting condition.</li> </ul>	MOTOR LIMITS	b3	<ul style="list-style-type: none"> <li>Blocked filters.</li> <li>Restrictive ductwork.</li> <li>Undersized ductwork.</li> <li>High ambient temperatures.</li> </ul>	<ul style="list-style-type: none"> <li>Check filters for blockage.</li> <li>Clean filters or remove obstruction.</li> <li>Check ductwork for blockage. Remove obstruction. Verify all registers are fully open.</li> <li>Verify ductwork is appropriately sized for system. Resize/replace ductwork if necessary.</li> <li>See "Installation Instructions" for installation requirements.</li> </ul>	<ul style="list-style-type: none"> <li>Turn power OFF prior to repair.</li> </ul>
<ul style="list-style-type: none"> <li>Modular blower fails to operate.</li> <li>Integrated control module LED display provides indicated error code.</li> <li>ComfortNet™ thermostat "Call for Service" icon illuminated.</li> <li>ComfortNet™ thermostat scrolls "Check Air Handler" message.</li> </ul>	b4	<ul style="list-style-type: none"> <li>Circulator blower motor senses a loss rotor control.</li> <li>Circulator blower motor senses high current.</li> </ul>	MOTOR TRIPS	b4	<ul style="list-style-type: none"> <li>Abnormal motor loading, sudden change in speed or torque, sudden blockage of modular blower/coil air inlet or outlet.</li> <li>High loading conditions, blocked filters, very restrictive ductwork, blockage of modular blower/coil air inlet or outlet.</li> </ul>	<ul style="list-style-type: none"> <li>Check filters, filter grills/registers, duct system, and modular blower/coil air inlet/outlet for blockages.</li> </ul>	<ul style="list-style-type: none"> <li>Turn power OFF prior to repair.</li> </ul>

# TROUBLESHOOTING INFORMATION: AIR HANDLER DIAGNOSTIC CODES

Symptoms of Abnormal Operation (Legacy & ComfortNet™ Thermostat)	7-Segment LED Codes	Fault Description	ComfortNet™ Thermostat Only		Possible Causes	Corrective Actions	Notes & Cautions
			Message	Code			
<ul style="list-style-type: none"> <li>Modular blower fails to operate.</li> <li>Integrated control module LED display provides indicated error code.</li> <li>ComfortNet™ thermostat "Call for Service" icon illuminated.</li> <li>ComfortNet™ thermostat scrolls "Check Air Handler" message.</li> </ul>	b5	<ul style="list-style-type: none"> <li>Circulator blower motor fails to start 10 consecutive times.</li> </ul>	MTR LCKD ROTOR	b5	<ul style="list-style-type: none"> <li>Obstruction in circulator blower housing.</li> <li>Seized circulator blower motor bearings.</li> <li>Failed circulator blower motor.</li> </ul>	<ul style="list-style-type: none"> <li>Check circulator blower for obstructions. Remove and repair/replace wheel/motor if necessary.</li> <li>Check circulator blower motor shaft rotation and motor. Replace motor if necessary.</li> </ul>	<ul style="list-style-type: none"> <li>Turn power OFF prior to repair.</li> <li>Replace motor with correct replacement part.</li> <li>Replace wheel with correct replacement part.</li> </ul>
<ul style="list-style-type: none"> <li>Modular blower fails to operate.</li> <li>Integrated control module LED display provides indicated error code.</li> <li>ComfortNet™ thermostat "Call for Service" icon illuminated.</li> <li>ComfortNet™ thermostat scrolls "Check Air Handler" message.</li> </ul>	b6	<ul style="list-style-type: none"> <li>Circulator blower motor shuts down for over or under voltage condition.</li> <li>Circulator blower motor shuts down due to over temperature condition on power module.</li> </ul>	MOTOR VOLTS	b6	<ul style="list-style-type: none"> <li>High AC line voltage to modular blower.</li> <li>Low AC line voltage to modular blower.</li> <li>High ambient temperatures.</li> </ul>	<ul style="list-style-type: none"> <li>Check power to modular blower. Verify line voltage to blower is within the range specified on the modular blower rating plate.</li> <li>See "Installation Instructions" for installation requirements.</li> </ul>	<ul style="list-style-type: none"> <li>Turn power OFF prior to repair.</li> </ul>
<ul style="list-style-type: none"> <li>Modular blower fails to operate.</li> <li>Integrated control module LED display provides indicated error code.</li> <li>ComfortNet™ thermostat "Call for Service" icon illuminated.</li> <li>ComfortNet™ thermostat scrolls "Check Air Handler" message.</li> </ul>	b7	<ul style="list-style-type: none"> <li>Circulator blower motor does not have enough information to operate properly. Motor fails to start 40 consecutive times.</li> </ul>	MOTOR PARAMS	b7	<ul style="list-style-type: none"> <li>Error with integrated control module.</li> <li>Motor has a locked rotor condition.</li> </ul>	<ul style="list-style-type: none"> <li>Check integrated control module. Verify control is populated with correct shared data set. See data errors above for details.</li> <li>Check for locked rotor condition (see error code above for details).</li> </ul>	<ul style="list-style-type: none"> <li>Turn power OFF prior to repair.</li> <li>Replace with correct replacement part(s).</li> <li>Use memory card for the specific model.</li> <li>Insert memory card BEFORE turning power ON.</li> <li>Memory card may be removed after data is loaded.</li> <li>Turn power off before removing memory card.</li> </ul>
<ul style="list-style-type: none"> <li>Modular blower operates at reduced performance or operates on low stage when high stage is expected.</li> <li>Integrated control module LED display provides indicated error code.</li> </ul>	b9	<ul style="list-style-type: none"> <li>Airflow is lower than demanded.</li> </ul>	LOW/D AIRFLOW	b9	<ul style="list-style-type: none"> <li>Blocked filters.</li> <li>Restrictive ductwork.</li> <li>Undersized ductwork.</li> </ul>	<ul style="list-style-type: none"> <li>Check filters for blockage. Clean filters or remove obstruction.</li> <li>Check ductwork for blockage. Remove obstruction. Verify all registers are fully open.</li> <li>Verify ductwork is appropriately sized for system. Resize/replace ductwork if necessary.</li> </ul>	<ul style="list-style-type: none"> <li>Turn power OFF prior to repair.</li> </ul>

# TROUBLESHOOTING INFORMATION: AIR HANDLER DIAGNOSTIC CODES

7 SEGMENT LED (characters will alternate)	DESCRIPTION OF CONDITION
(no display)	INTERNAL CONTROL FAULT / NO POWER
On	STANDBY, WAITING FOR INPUTS
Ec	HEATER KIT TOO LARGE, TOO SMALL, OR NO MATCH
E5	FUSE OPEN
EF	AUXILIARY SWITCH OPEN
d0	DATA NOT ON NETWORK
d1	INVALID DATA ON NETWORK
d4	INVALID MEMORY CARD DATA
b0	BLOWER MOTOR NOT RUNNING
b1	BLOWER MOTOR COMMUNICATION ERROR
b2	BLOWER MOTOR HP MISMATCH
b3	BLOWER MOTOR OPERATING IN POWER, TEMP., OR SPEED LIMIT
b4	BLOWER MOTOR CURRENT TRIP OR LOST ROTOR
b5	BLOWER MOTOR ROTOR LOCKED
b6	OVER/UNDER VOLTAGE TRIP OR OVER TEMPERATURE TRIP
b7	INCOMPLETE PARAMETER SENT TO MOTOR
b9	LOW INDOOR AIRFLOW
C1	LOW STAGE COOL - LEGACY MODE ONLY
C2	HIGH STAGE COOL - LEGACY MODE ONLY
P1	LOW STAGE HEAT PUMP HEAT - LEGACY MODE ONLY
P2	HIGH STAGE HEAT PUMP HEAT - LEGACY MODE ONLY
h1	EMERGENCY HEAT LOW - COMMUNICATING MODE ONLY
h2	EMERGENCY HEAT HIGH - COMMUNICATING MODE ONLY
FC	FAN COOL - COMMUNICATING MODE ONLY
FH	FAN HEAT - COMMUNICATING MODE ONLY
F	FAN ONLY
H1	ELECTRIC HEAT LOW
H2	ELECTRIC HEAT HIGH
dF	DEFROST - COMMUNICATING MODE ONLY (Note: defrost is displayed as H1 in a legacy setup)
GREEN CFM LED - EACH FLASH REPRESENTS 100CFM (USE FOR AIRFLOW APPROXIMATION ONLY) - EXAMPLE: 8 FLASHES = 800CFM	
0140A00070-A	

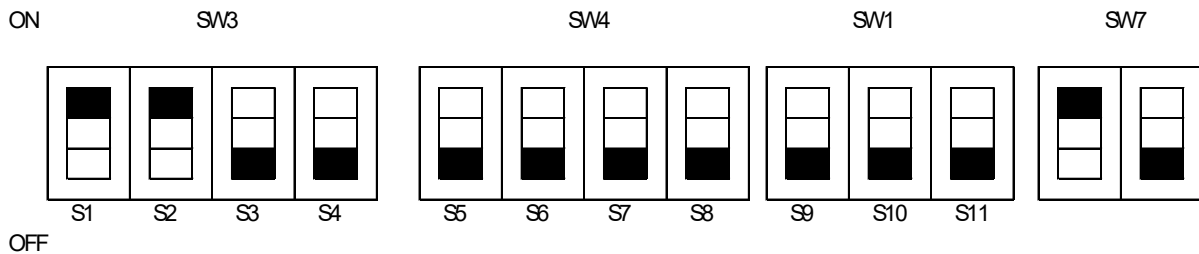

FACTORY DIP SWITCH SETTINGS

WIRING DIAGRAM

**WARNING** HIGH VOLTAGE! DISCONNECT ALL POWER BEFORE SERVICING. MULTIPLE POWER SOURCES MAY BE PRESENT. FAILURE TO DO SO MAY CAUSE PROPERTY DAMAGE, PERSONAL INJURY OR DEATH.

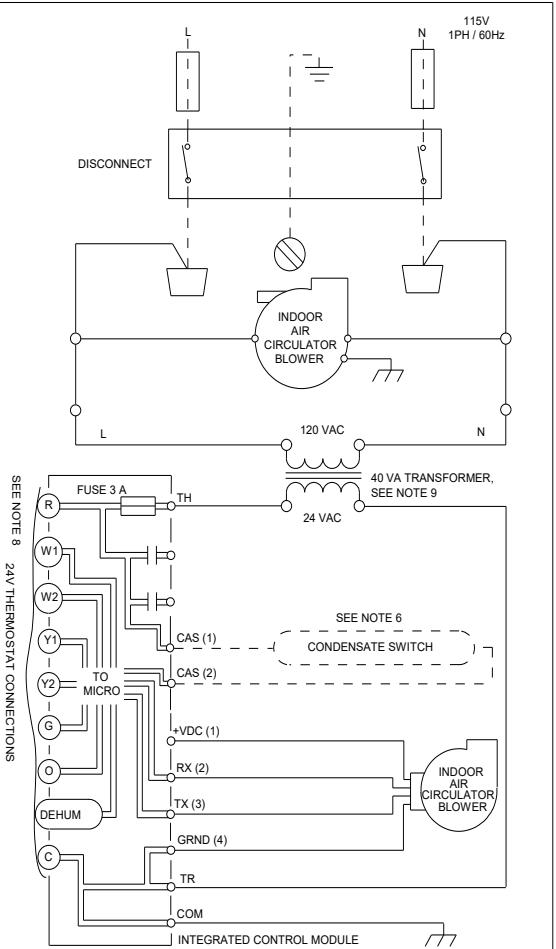
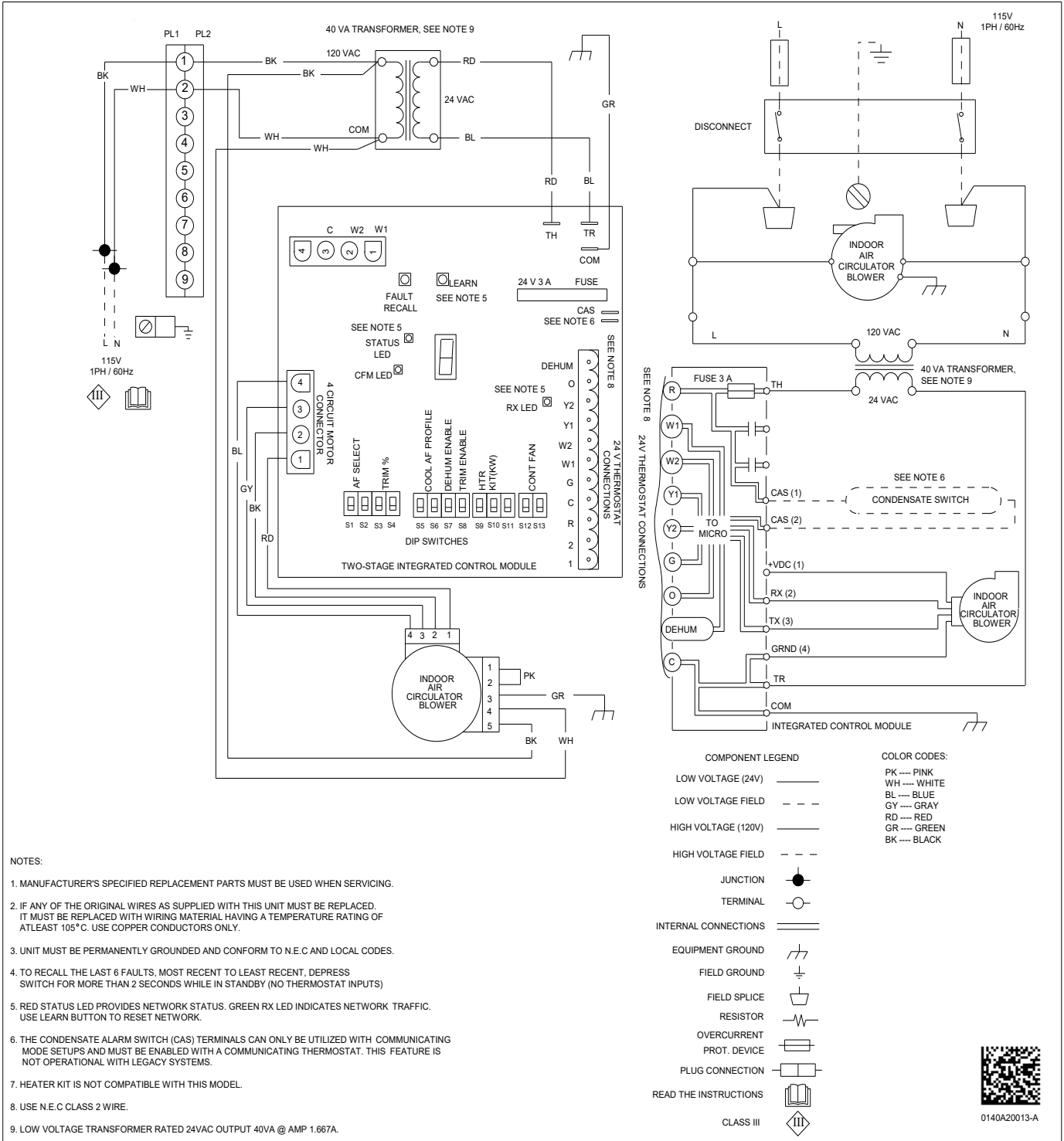

**COMPONENT LEGEND**

LOW VOLTAGE (24V) ———

LOW VOLTAGE FIELD - - -

HIGH VOLTAGE (120V) ———

HIGH VOLTAGE FIELD - - -

JUNCTION ●

TERMINAL ○

INTERNAL CONNECTIONS ———

EQUIPMENT GROUND ⚡

FIELD GROUND ⊥

FIELD SPLICE ⚡

RESISTOR ⚡

OVERCURRENT PROT. DEVICE ⚡

PLUG CONNECTION ⚡

READ THE INSTRUCTIONS 📖

CLASS III ⚡

**COLOR CODES:**

PK ---- PINK

WH ---- WHITE

BL ---- BLUE

GY ---- GRAY

RD ---- RED

GR ---- GREEN

BK ---- BLACK

0140A20013-A

- NOTES:**
1. MANUFACTURER'S SPECIFIED REPLACEMENT PARTS MUST BE USED WHEN SERVICING.
  2. IF ANY OF THE ORIGINAL WIRES AS SUPPLIED WITH THIS UNIT MUST BE REPLACED, IT MUST BE REPLACED WITH WIRING MATERIAL HAVING A TEMPERATURE RATING OF ATLEAST 105°C. USE COPPER CONDUCTORS ONLY.
  3. UNIT MUST BE PERMANENTLY GROUNDING AND CONFORM TO N.E.C AND LOCAL CODES.
  4. TO RECALL THE LAST 6 FAULTS, MOST RECENT TO LEAST RECENT, DEPRESS SWITCH FOR MORE THAN 2 SECONDS WHILE IN STANDBY (NO THERMOSTAT INPUTS)
  5. RED STATUS LED PROVIDES NETWORK STATUS. GREEN RX LED INDICATES NETWORK TRAFFIC. USE LEARN BUTTON TO RESET NETWORK.
  6. THE CONDENSATE ALARM SWITCH (CAS) TERMINALS CAN ONLY BE UTILIZED WITH COMMUNICATING MODE SETUPS AND MUST BE ENABLED WITH A COMMUNICATING THERMOSTAT. THIS FEATURE IS NOT OPERATIONAL WITH LEGACY SYSTEMS.
  7. HEATER KIT IS NOT COMPATIBLE WITH THIS MODEL.
  8. USE N.E.C CLASS 2 WIRE.
  9. LOW VOLTAGE TRANSFORMER RATED 24VAC OUTPUT 40VA @ AMP 1.667A.

Wiring is subject to change, always refer to the wiring diagram on the unit for the most up-to-date wiring.

# AIR HANDLER

## AIR HANDLER HOMEOWNER'S ROUTINE MAINTENANCE RECOMMENDATIONS

We strongly recommend a bi-annual maintenance checkup be performed before the heating and cooling seasons begin by a qualified servicer.

### REPLACE OR CLEAN FILTER

**IMPORTANT NOTE:** Never operate unit without a filter installed as dust and lint will build up on internal parts resulting in loss of efficiency, equipment damage and possible fire.

An indoor air filter must be used with your comfort system. A properly maintained filter will keep the indoor coil of your comfort system clean. A dirty coil could cause poor operation and/or severe equipment damage.

Your air filter or filters could be located in your furnace, in a blower unit, or in "filter grilles" in your ceiling or walls. The installer of your air conditioner or heat pump can tell you where your filter(s) are, and how to clean or replace them.

Check your filter(s) at least once a month. When they are dirty, replace or clean as required. Disposable type filters should be replaced. Reusable type filters may be cleaned.

You may want to ask your dealer about high efficiency filters. High efficiency filters are available in both electronic and non-electronic types. These filters can do a better job of catching small airborne particles.

**WARNING**



**HIGH VOLTAGE!**  
DISCONNECT ALL POWER BEFORE SERVICING OR INSTALLING THIS UNIT. MULTIPLE POWER SOURCES MAY BE PRESENT. FAILURE TO DO SO MAY CAUSE PROPERTY DAMAGE, PERSONAL INJURY OR DEATH.

### MOTORS

Indoor and outdoor fan motors are permanently lubricated and do not require additional oiling.

### ALUMINUM INDOOR COIL CLEANING

#### (QUALIFIED SERVICER ONLY)

This unit is equipped with an aluminum tube evaporator coil. The safest way to clean the evaporator coil is to simply flush the coil with water. This cleaning practice remains as the recommended cleaning method for both copper tube and aluminum tube residential evaporator coils.

It has been determined that many coil cleaners and drain pan tablets contain corrosive chemicals that can be harmful to aluminum tube and fin evaporator coils. Even a one-time application of these corrosive chemicals can cause premature aluminum evaporator coil failure. Any cleaners that contain corrosive chemicals including, but not limited to, chlorine and hydroxides, should not be used.

An alternate cleaning method is to use one of the products listed in TP-109\* to clean the coils. The cleaners listed are the only agents deemed safe and approved for use to clean round tube aluminum coils. TP-109 is also available on the web site in Partner Link > Service Toolkit.

NOTE: Ensure coils are rinsed well after use of any chemical cleaners.



### CAUTION

**TO AVOID THE RISK OF EQUIPMENT DAMAGE OR FIRE, INSTALL THE SAME AMPERAGE BREAKER OR FUSE AS YOU ARE REPLACING. IF THE CIRCUIT BREAKER OR FUSE SHOULD OPEN AGAIN WITHIN THIRTY DAYS, CONTACT A QUALIFIED SERVICER TO CORRECT THE PROBLEM. IF YOU REPEATEDLY RESET THE BREAKER OR REPLACE THE FUSE WITHOUT HAVING THE PROBLEM CORRECTED, YOU RUN THE RISK OF SEVERE EQUIPMENT DAMAGE.**

### BEFORE YOU CALL YOUR SERVICER

- Check the thermostat to confirm that it is properly set.
- Wait 15 minutes. Some devices in the outdoor unit or in programmable thermostats will prevent compressor operation for awhile, and then reset automatically. Also, some power companies will install devices which shut off air conditioners for several minutes on hot days. If you wait several minutes, the unit may begin operation on its own.
- Check the electrical panel for tripped circuit breakers or open fuses. Reset the circuit breakers or replace fuses as necessary.
- Check the disconnect switch near the indoor furnace or blower to confirm that it is closed.
- Check for obstructions on the outdoor unit. Confirm that it has not been covered on the sides or the top. Remove any obstruction that can be safely removed. If the unit is covered with dirt or debris, call a qualified servicer to clean it.
- Check for blockage of the indoor air inlets and outlets. Confirm that they are open and have not been blocked by objects (rugs, curtains or furniture).
- Check the filter. If it is dirty, clean or replace it.
- Listen for any unusual noise(s), other than normal operating noise, that might be coming from the outdoor unit. If you hear unusual noise(s) coming from the unit, call a qualified servicer.

**Air Handler / Coil**

Model Number \_\_\_\_\_

Serial Number \_\_\_\_\_

**ELECTRICAL**

Line Voltage (Measure L and N Voltage)

L - N \_\_\_\_\_

Secondary Voltage (Measure Transformer Output Voltage)

R - C \_\_\_\_\_

Blower Amps

Heat Strip 1 - Amps

Not Applicable

Heat Strip 2 - Amps

Not Applicable

**BLOWER EXTERNAL STATIC PRESSURE**

Return Air Static Pressure

\_\_\_\_\_ IN. W.C.

Supply Air Static Pressure

\_\_\_\_\_ IN. W.C.

Total External Static Pressure (Ignoring +/- from the reading above, add total here)

\_\_\_\_\_ IN. W.C.

**TEMPERATURES**

Return Air Temperature (Dry bulb / Wet bulb)

\_\_\_\_\_ DB °F      \_\_\_\_\_ WB °F

Cooling Supply Air Temperature (Dry bulb / Wet bulb)

\_\_\_\_\_ DB °F      \_\_\_\_\_ WB °F

Heating Supply Air Temperature

\_\_\_\_\_ DB °F

Temperature Rise

\_\_\_\_\_ DB °F

Delta T (Difference between Supply and Return Temperatures)

\_\_\_\_\_ DB °F

**Air Handler / Coil - (Inverter Matched)**

**INVERTER AH / COIL ONLY**

Check EEV and EEV wiring is secure (no adjustment required)

\_\_\_\_\_

**Additional Checks**

Check wire routings for any rubbing

\_\_\_\_\_

Check product for proper draining

\_\_\_\_\_

Check screw tightness on blower wheel

\_\_\_\_\_

Check factory wiring and wire connections

\_\_\_\_\_

Check product for proper clearances as noted by installation instructions

\_\_\_\_\_

°F to °C formula: (°F - 32) divided by 1.8 = °C

°C to °F formula: (°C multiplied by 1.8) + 32 = °F

**THIS PAGE INTENTIONALLY LEFT BLANK**

CUSTOMER FEEDBACK

We are very interested in all product comments.

Please fill out the feedback form on one of the following links:

Daikin Products: (<https://daikincomfort.com/contact-us>)

Goodman® Brand Products: (<http://www.goodmanmfg.com/about/contact-us>).

Amana® Brand Products: (<http://www.amana-hac.com/about-us/contact-us>).

You can also scan the QR code on the right for the product brand you purchased to be directed to the feedback page.



DAIKIN



GOODMAN® BRAND



AMANA® BRAND

NOTE: SPECIFICATIONS AND PERFORMANCE DATE LISTED HEREIN ARE SUBJECT TO CHANGE WITHOUT NOTICE.

Visit our website at [www.goodmanmfg.com](http://www.goodmanmfg.com) or [www.amana-hac.com](http://www.amana-hac.com) for information on:

- Products
- Warranties
- Customer Services
- Parts
- Contractor Programs and Training
- Financing Options

Daikin Comfort Technologies Manufacturing, Inc.

19001 Kermier Rd., Waller, TX 77484

©2025-2026

**Amana** is a registered trademark of Maytag or its related companies and is used under license. All rights reserved.