

NON-A2L FURNACE INTEGRATION KIT

INSTALLATION INSTRUCTIONS

ATTENTION INSTALLING PERSONNEL

As a professional installer, you have an obligation to know the product better than the customer. This includes all safety precautions and related items.

Prior to the actual installation, thoroughly familiarize yourself with this instruction manual. Pay special attention to all safety warnings. Often during installation or repair, it is possible to place yourself in a position which is more hazardous than when the unit is in operation.



Remember, it is your responsibility to install the product safely and to know it well enough to be able to instruct a customer in its safe use.

Safety is a matter of common sense. A matter of thinking before acting. Most dealers have a list of specific good safety practices. Follow them.

The precautions listed in this installation manual are intended as supplemental to existing practices. However, if there is a direct conflict between existing practices and the content of this manual, the precautions listed here take precedence.

SAFETY PRECAUTIONS

The following symbols and labels are used throughout this manual to indicate immediate or potential safety hazards. It is the owner's and installer's responsibility to read and comply with all safety information and instructions accompanying these symbols. Failure to heed safety information increases the risk of personal injury, property damage, and/or product damage.

 WARNING
<p>HIGH VOLTAGE DISCONNECT ALL POWER BEFORE SERVICING THIS UNIT. MULTIPLE POWER SOURCES MAY BE PRESENT. FAILURE TO DO SO MAY CAUSE PROPERTY DAMAGE, PERSONAL INJURY OR DEATH.</p> 

If the installation check, as detailed in these installation instructions, does not pass successfully and cannot be resolved by calling 1-855 DAIKIN1, option 3 for further assistance, the installer must replace the furnace or modular blower with an R-32 compatible furnace or modular blower.

 WARNING
<p>DO NOT BYPASS SAFETY DEVICES.</p>

 WARNING
<p>ONLY PERSONNEL THAT HAVE BEEN TRAINED TO INSTALL, ADJUST, SERVICE, MAINTENANCE OR REPAIR (HEREINAFTER, "SERVICE") THE EQUIPMENT SPECIFIED IN THIS MANUAL SHOULD SERVICE THE EQUIPMENT.</p> <p>THIS EQUIPMENT IS NOT INTENDED FOR USE BY PERSONS (INCLUDING CHILDREN) WITH REDUCED PHYSICAL, SENSORY OR MENTAL CAPACITIES, OR LACK OF EXPERIENCE AND KNOWLEDGE, UNLESS THEY HAVE BEEN GIVEN SUPERVISION OR INSTRUCTION CONCERNING USE OF THE APPLIANCE BY A PERSON RESPONSIBLE FOR THEIR SAFETY.</p> <p>CHILDREN SHOULD BE SUPERVISED TO ENSURE THAT THEY DO NOT PLAY WITH THE EQUIPMENT.</p> <p>THE MANUFACTURER WILL NOT BE RESPONSIBLE FOR ANY INJURY OR PROPERTY DAMAGE ARISING FROM IMPROPER SUPERVISION, SERVICE OR SERVICE PROCEDURES. IF YOU SERVICE THIS UNIT, YOU ASSUME RESPONSIBILITY FOR ANY INJURY OR PROPERTY DAMAGE WHICH MAY RESULT. IN ADDITION, IN JURISDICTIONS THAT REQUIRE ONE OR MORE LICENSES TO SERVICE THE EQUIPMENT SPECIFIED IN THIS MANUAL, ONLY LICENSED PERSONNEL SHOULD SERVICE THE EQUIPMENT. IMPROPER SUPERVISION, INSTALLATION, ADJUSTMENT, SERVICING, MAINTENANCE OR REPAIR OF THE EQUIPMENT SPECIFIED IN THIS MANUAL, OR ATTEMPTING TO INSTALL, ADJUST, SERVICE OR REPAIR THE EQUIPMENT SPECIFIED IN THIS MANUAL WITHOUT PROPER SUPERVISION OR TRAINING MAY RESULT IN PRODUCT DAMAGE, PROPERTY DAMAGE, PERSONAL INJURY OR DEATH.</p>

Items needed in kit:	Qty
IO Manual	1
PCB Case containing the PCB	1
Connector Pin 1	1
Connector Pin 2	1
Connector Pin 3	1
Mounting hardware (screws)	4
Mounting hardware (wall anchors)	4



The most up-to-date installation instructions can be accessed by scanning the QR code below. If you have any questions, please contact our Technical Service team.



QR code for Installation Manual

The Non-A2L Furnace Integration Kit was designed to support the HVAC replacement market for systems containing 1) a Furnace, Indoor Coil and Outdoor Air Conditioner or Heat Pump unit or 2) a Modular Blower, Indoor Coil and Outdoor Air Conditioner or Heat Pump unit. If either the indoor coil or outdoor unit needs to be replaced, both must

be upgraded to R-32 models. If the furnace or modular Blower is still operational, it does not need to be replaced.

NOTE: If the installation check, as detailed in these installation instructions, does not pass successfully and cannot be resolved by calling service for further assistance, the installer must replace the furnace or modular blower with an R-32 compatible furnace or modular blower. The Non-A2L Furnace Integration Kit relies on existing functions of the currently installed furnace or modular blower control boards or PCBs to achieve the necessary mitigation function required for a system utilizing R-32 refrigerant. Therefore, it is important to verify the function of the system, as detailed in the “Verification of R-32 Leak Mitigation” section of this manual.

Images of PCB layout showing connector labeling below

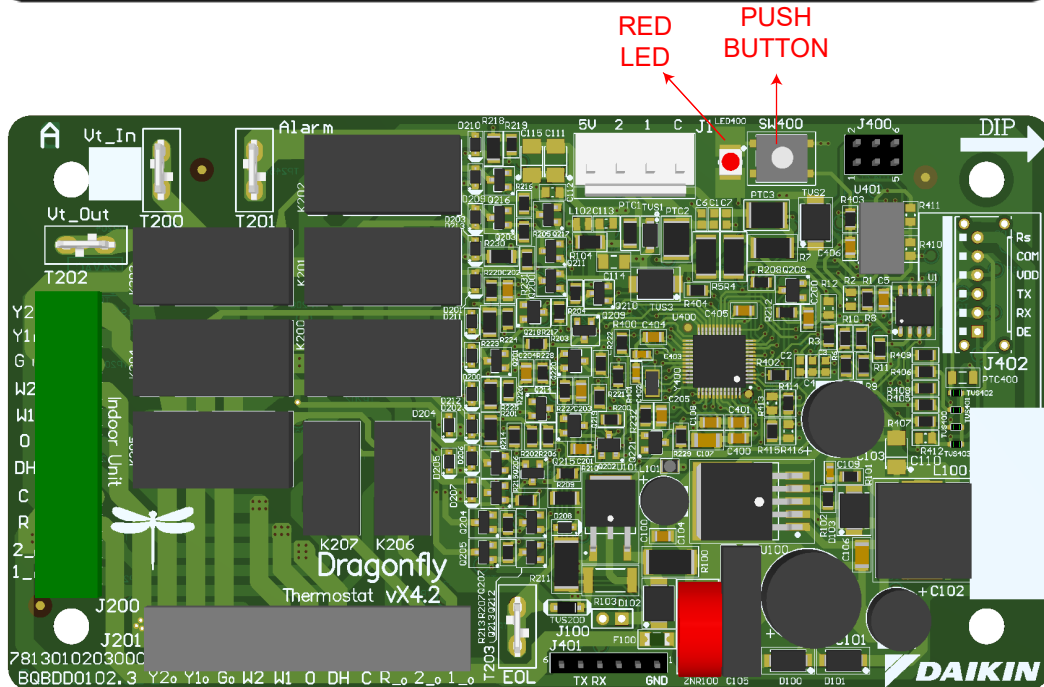
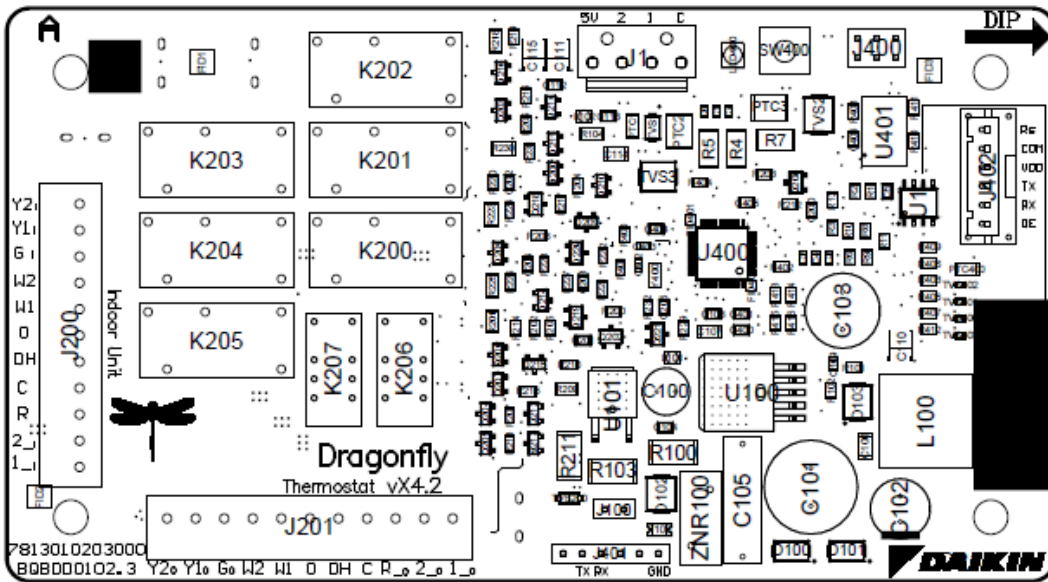

NOTE: Under no circumstances shall the refrigerant detection and mitigation functionality of Non-A2L Furnace Integration Kit and gas Sensor be bypassed. Third-party accessories are not tested or approved by Daikin, and it is the responsibility of the installer to select compatible accessories.

NOTE: R-32 is an A2L classified refrigerant which requires a refrigerant leakage detection system to be installed. The Non-A2L Furnace Integration Kit, when connected with an R-32 gas sensor, is a refrigerant leak detection system. The Non-A2L Furnace Integration Kit is designed to be installed externally to the cased coil and furnace. It should never be physically mounted anywhere on the cased coil or the furnace. The kit can be mounted to a wall near the unit, on a wood beam, on the furnace return duct or other locations deemed acceptable. The kit can be mounted using the wall anchors and screws provided with the kit. The kit must always be accessible and serviceable. This manual will explain how to wire and test a new installation where the original furnace or modular blower remains installed while the indoor coil and outdoor unit are replaced with R-32 models.

NON-A2L FURNACE INTEGRATION KIT OPERATING PRINCIPLE

NON-A2L FURNACE INTEGRATION KIT is designed to read R-32 sensor concentration and utilize existing function of indoor PCBs to mitigate R-32 leakage in an unlikely event of a leak in the system. The integration kit continuously monitors the system for R-32 leaks and does not impact the normal operation of the unit when no leak/sensor fault is detected.

A simplified version of operating principle of the integration kit is described here. For a more in-depth understanding of the integration kit's operating principle, please contact technical service.

The integration kit has two screw terminal headers – Indoor Unit (Green) and Thermostat (Black). The integration kit is connected between the thermostat and indoor unit, and it controls the traffic of signals between the thermostat and indoor unit, based on the R-32 concentration.

1. R-32 Concentration detection: The integration kit is connected to a refrigerant sensor, which detects R-32 concentration. The sensor transmits the concentration, and the integration kit acts based on the concentration.
2. When R-32 concentration is at safe level, the integration kit, does not interfere between the thermostat and indoor unit. All signals are passed-through.
3. When R-32 concentration is above a certain level or the R-32 sensor or the integration kit encounters a fault, the integration kit, energizes the G (fan)

terminal in the indoor unit by sending a 24VAC signal. It also disconnects the R signal to the thermostat and/or, disconnects ClimateTalk® communication, as applicable. This action will terminate all HVAC operation (Cooling or Heating) while keeping the main blower on to dissipate any refrigerant gas.

NON-A2L FURNACE INTEGRATION KIT PRE-CHECKS

The NON-A2L FURNACE INTEGRATION KIT works successfully if the following are true for the thermostat and furnace or modular blower. While these conditions are true for most thermostats and furnace or modular blower, please consult the user manual of the thermostat and furnace or modular blower to verify. If the thermostat or furnace or modular blower does not conform to these common operating principles, please contact technical service to identify a compatible thermostat and/or furnace or modular blower. Do not install R-32 coil and/or outdoor unit if the thermostat or the furnace or modular blower is not compatible.

1. **Standard 24VAC Thermostat:** R signal of the thermostat is the source of Y1/Y2, W1/W2, G and other signals. Please verify this by disconnecting the R signal in the thermostat. If the thermostat powers off, then the thermostat is compatible. If the thermostat is still powered on (by alternate power source or battery), lower and increase the thermostat setpoint to activate COOLING and HEATING call, respectively to the indoor unit. In either case, the indoor unit and outdoor unit shall not operate in COOLING or HEATING mode, respectively.
2. **Non-communicating Indoor Unit:** Non-communicating indoor units must activate blower fan within 15 seconds, when a G call is presented to activate the blower fan. This can be verified, by putting the system in FAN ONLY mode. The blower shall activate within 15 seconds after the thermostat provides 24VAC on the G terminal.
3. **Communicating Indoor Unit:** Communicating indoor units must prioritize 24VAC calls, over ClimateTalk® communication and activate blower fan within 15 seconds, when a G call is presented over 24VAC signal. This is true for all *ComfortNet* systems. However, *ComfortBridge* systems, may require a firmware upgrade – therefore, please do not install the R-32 Coil and outdoor, until the latest firmware is installed in *ComfortBridge* system, via *CoolCloud* app (version available for download on your mobile device).
4. **Tools Needed:** A 1/8" flat head screwdriver.
5. Identify thermostat wires in the indoor unit and note it down. It will greatly help to identify the wires later.

Indoor Unit Terminal	Color of the Wire from Thermostat	Color of the Wire to Outdoor Unit	Color of the Wire to EEV Unit
R			
C			
G			
Y1			
Y2			
W1			
W2			
DH			
O			
1			
2			

6. **Recommended:** A flexible light source so that indoor unit terminals can be illuminated hands-free. It is also recommended to have sufficient light near the indoor unit terminals.
7. **Recommended:** A copy of the wiring diagram of the existing indoor unit, to identify the indoor unit terminals (R, Y1/2, W1/2, C, 1, 2 etc) as applicable.
8. **Recommended:** A picture of the existing installation and wiring, before disconnecting the wires.

NON-A2L FURNACE INTEGRATION KIT WORK SCOPE

During installation of the kit:

1. Disconnect wires coming from thermostat and outdoor unit to indoor unit.
2. Connect appropriate wires from thermostat to the integration kit's "Thermostat" terminals.
3. Use new wires to connect the integration kit's "Indoor Unit" terminals to the indoor.
4. If applicable, disconnect 4 wires for EEV coil from Indoor unit, and connect them to PCB's "Indoor Unit" terminal per the wiring diagram provided on page 10.
5. Complete the verification step.
 - a. Verify normal operation.
 - b. Verify mitigation function.
 - c. Verify system returns to normal operation.
6. Install and mount the kit.

Please consult the WIRING FOR VARIOUS CONTROL SYSTEM section below, to understand the scope of wiring.

NON-A2L FURNACE INTEGRATION KIT INSTALLATION STEPS

RUNNING THE SYSTEM TEST IS MANDATORY FOR ALL INSTALLATIONS. THE HVAC SYSTEM COMMISSIONING IS NOT COMPLETE UNTIL THE INSTALLATION STEPS LISTED IN THIS MANUAL HAVE BEEN SUCCESSFULLY COMPLETED.

IMPORTANT NOTE: IF INSTALLING A CONDENSATE FLOAT SWITCH, SEE WIRING DIAGRAM IN THIS IO MANUAL. THE FLOAT SWITCH MUST BE UL RECOGNIZED, NORMALLY CLOSED FLOAT SWITCH THAT OPENS A SET OF CONTACTS AS THE WATER LEVEL RISES. ANY OTHER TYPE OF FLOAT SWITCHES ARE NOT COMPATIBLE WITH THIS APPLICATION.

Identify the type of control system being installed.

- a. Non-Communicating System (indoor / outdoor units that only use standard thermostat inputs such as Y, W and G for control).
- b. ComfortBridge Communicating System (indoor unit contains a ComfortBridge control and is connected to the outdoor unit using wire terminals labeled 1 and 2. Indoor unit is then connected to thermostat using standard thermostat inputs such as Y, W and G).

NOTE: IF YOU HAVE THIS TYPE OF SYSTEM, MAKE SURE ALL AVAILABLE SOFTWARE UPDATES HAVE BEEN MADE TO THE INDOOR CONTROL BOARD USING THE COOL CLOUD HVAC PHONE APPLICATION BEFORE CONTINUING TO INSTALL THE NON-A2L FURNACE INTEGRATION KIT. (2 STAGE FURNACE: SOFTWARE VERSION 11 OR GREATER. MODULATING FURNACE: SOFTWARE VERSION 8 OR GREATER. ULTRA LOW NOX FURNACE: SOFTWARE VERSION 11 OR GREATER).

- c. ComfortBridge Non-Communicating System (Indoor unit contains a ComfortBridge control but the outdoor unit is wired as a non-communicating system meaning standard thermostat inputs such as Y and W are used. In this case, the indoor unit ComfortBridge control contains terminals labeled 1 and 2, but they are not in use).

NOTE: IF YOU HAVE THIS TYPE OF SYSTEM, MAKE SURE ALL AVAILABLE SOFTWARE UPDATES HAVE BEEN MADE TO THE INDOOR CONTROL BOARD USING THE COOL CLOUD HVAC PHONE APPLICATION BEFORE CONTINUING TO INSTALL THE NON-A2L FURNACE INTEGRATION KIT. (2 STAGE FURNACE: SOFTWARE VERSION 11 OR GREATER. MODULATING FURNACE: SOFTWARE VERSION 8 OR GREATER. ULTRA LOW NOX FURNACE: SOFTWARE VERSION 11 OR GREATER).
- d. *ComfortNet* Communicating System (Indoor unit, Outdoor unit and Thermostat are all connected using terminals labeled 1 and 2).
- e. *ComfortNet* Communicating System with EEV Coil (Indoor unit, Outdoor unit, EEV Coil and Thermostat are all connected using terminals labeled 1 and 2).
- f. *ComfortNet* Mixed Mode System (Indoor unit and communicating thermostat are connected using terminals labeled 1 and 2. Single stage non-communicating outdoor AC unit is controlled by the indoor control board's Y terminal).
- g. *ComfortNet* Non-Communicating System (Indoor and/or outdoor unit contains a *ComfortNet* control, but they are not wired together using terminals labeled 1 and 2. All wiring is done using standard thermostat inputs such as Y, W and G).

- Using the appropriate wiring diagram that matches the controls being installed, make all the appropriate wire connections using standard thermostat wire. It is not recommended to insert multiple wires into a single terminal block. Using wire nuts is recommended to achieve this.

NOTE: FOR COMFORTNET SYSTEMS THAT ARE USING A 4 PIN GREEN CONNECTOR (1, 2, R, C TERMINALS), THE KIT CONTAINS A 5 PIN GREEN CONNECTOR WITH AN ADDED G TERMINAL THAT IS REQUIRED TO COMPLETE THE WIRING. REPLACE THE EXISTING 4 PIN GREEN CONNECTOR WITH THE NEW 5 PIN CONNECTOR INCLUDED.

- Connect the R-32 sensor from the coil to the Non-A2L Furnace Integration Kit control board (4 pin connection point). **ATTENTION! AFTER THE CONNECTION OF THE A2L SENSOR AND THE NON-A2L FURNACE INTEGRATION KIT, ENSURE THE A2L SENSOR IS KEPT IN ITS ORIGINAL LOCATION AND CORRECTLY MOUNTED IN THE SENSOR BRACKET.**

IMPORTANT: IF SENSOR IS NOT CONNECTED BEFORE POWERING UP, THE SYSTEM WILL ENTER LEAK MITIGATION MODE. ONCE THE SYSTEM ENTERS LEAK MITIGATION MODE, IT MAY STAY THERE APPROXIMATELY 5 MINUTES, EVEN IF THE BOARD LOSES POWER (I.E. POWER CYCLED). THEREFORE, IT IS STRONGLY ADVISED TO CONNECT THE SENSOR, BEFORE POWERING UP.

- Turn power on to indoor and outdoor units (this will apply power to the Non-A2L Furnace Integration Kit control board) and make sure the thermostat is in the OFF mode (no cooling or heating calls being made). The red LED on the Non-A2L Furnace Integration Kit control board will start flashing slowly if the control is functioning properly (2 seconds on and 2 seconds off continuously).

NOTE: THE INDOOR BLOWER MIGHT RUN TEMPORARILY AFTER POWER IS APPLIED TO SYSTEM (THE BLOWER WILL TURN OFF AUTOMATICALLY).

NOTE: ANY ERRORS WILL ALSO SHOW UP ON THE RED LED OF THE NON-A2L FURNACE INTEGRATION KIT CONTROL BOARD. THESE WILL NEED TO BE ADDRESSED BEFORE PROCEEDING WITH THE SETUP INSTRUCTIONS.

- If a communicating system has been installed (*ComfortNet* or *ComfortBridge*), wait until the thermostat or phone application has clearly identified both the indoor unit and outdoor units before proceeding to step 6.

NOTE: IN A COMFORTNET MIXED MODE SYSTEM, THERE IS A COMMUNICATING INDOOR UNIT, BUT THE OUTDOOR UNIT IS NON-COMMUNICATING. ONCE THE THERMOSTAT IDENTIFIES THE INDOOR UNIT, IT IS OK TO PROCEED TO STEP 6.

- Test all modes of operation with the system to make sure they are functioning properly (Fan Only Mode, Cooling Mode, Heating Mode). This step does not involve the Non-A2L Furnace Integration Kit. The

purpose here is to confirm basic operation of the system before testing the Non-A2L Furnace Integration Kit functionality.

- (Mandatory for successful, safe installation) Verification of R-32 Leak Mitigation depending on one of the below systems.

7-1. FOR SYSTEMS WITH A 24VAC NON-COMMUNICATING OUTDOOR AIR CONDITIONER OR HEAT PUMP

Perform the control R-32 leakage test for all modes of operation one by one – Cooling, Heating, Emergency heating, Constant fan and Idle. Each test will take approximately 2 to 15 minutes.

- Set the thermostat to one of the operation modes and ensure system is running properly in that mode. Note which mode is being tested. The test sequence will need to be run again under the other modes as well.
- Locate the push button on the Non-A2L Furnace Integration Kit control and press it two times (See Reference to the push button on page 2). You will hear all the relays on the Non-A2L Furnace Integration Kit control switch as it goes into R-32 leak test mode. The Red LED will also start to flash rapidly during this 5-minute test mode.
- The HVAC operation that was chosen should turn off (compressor, electric heat, gas heat) after a short period of time (times will vary depending on the installed system but Electric Heat or Gas Heat should turn off within 30 seconds and the outdoor unit should turn off within 2 minutes).

NOTE: IF THE COMPRESSOR, ELECTRIC HEAT, OR GAS HEAT IS STILL OPERATING AFTER 2 MINUTES, THE NON-A2L FURNACE INTEGRATION KIT IS NOT FUNCTIONING PROPERLY. PLEASE RE-CHECK THE WIRING DIAGRAM FOR YOUR INSTALLED SYSTEM AND DO NOT CONTINUE UNTIL THE ISSUE HAS BEEN RESOLVED.

- The indoor blower will begin to operate within 30 seconds and remain running.

NOTE: IT IS NORMAL FOR THE INDOOR BLOWER TO RAMP UP OR DOWN DURING THIS TEST.

NOTE: IF A COMMUNICATING THERMOSTAT IS INSTALLED, A LOSS OF COMMUNICATIONS ERROR CODE MIGHT BE DISPLAYED ON THE THERMOSTAT SCREEN DURING THE TEST. IF THIS DOES NOT HAPPEN, IT IS OKAY TO PROCEED WITH THE TESTING AS LONG AS ALL HVAC OPERATION, OTHER THAN THE BLOWER, WERE CONFIRMED TO TURN OFF DURING THIS TEST.

- Once steps c and d have been confirmed, the test was successful. It is recommended to wait for the full 5-minute test to expire. However, pressing the same push button once will automatically exit this test mode.
- Wait for the system to return to the state it was in after the first step, to confirm the system will automatically recover, and then repeat the tests using the other HVAC modes not previously tested. It is extremely important to verify the Non-A2L

Furnace Integration Kit will function properly for all modes of operation.

NOTE: IF THE NON-A2L FURNACE INTEGRATION KIT IS NOT FUNCTIONING PROPERLY FOR ANY OF THE MODES, PLEASE RE-CHECK THE WIRING DIAGRAM FOR YOUR INSTALLED SYSTEM AND DO NOT CONTINUE UNTIL THE ISSUE HAS BEEN RESOLVED.

7-2. FOR SYSTEMS WITH A COMMUNICATING OUTDOOR AIR CONDITIONER OR HEAT PUMP

Perform the control R-32 leakage test for all modes of operation one by one – Cooling, Heating, Emergency heating, Constant fan and Idle. Each test will take approximately 2 to 15 minutes.

- a. Set the thermostat to one of the operation modes and ensure system is running properly in that mode. Note which mode is being tested. The test sequence will need to be run again under the other modes as well.
- b. Disconnect the R32 sensor from the Non-A2L Furnace Integration Kit control board. The relays will switch after 5 seconds and the LED will display a sensor communication fault (3 flashes followed by a 5 second delay before repeating the 3 flashes).
- c. Electric heat or gas heat will turn off after a short period of time (times will vary depending on the installed system but Electric Heat or Gas Heat should turn off within 30 seconds). The Communicating outdoor unit could take up to 12 minutes to turn off.

NOTE: IF ELECTRIC HEAT OR GAS HEAT IS STILL OPERATING AFTER 2 MINUTES, THE NON-A2L FURNACE INTEGRATION KIT IS NOT FUNCTIONING PROPERLY. IF THE COMMUNICATING OUTDOOR UNIT IS STILL OPERATING AFTER 12 MINUTES, THE NON-A2L FURNACE INTEGRATION KIT IS NOT FUNCTIONING PROPERLY. PLEASE RE-CHECK THE WIRING DIAGRAM FOR YOUR INSTALLED SYSTEM AND DO NOT CONTINUE UNTIL THE ISSUE HAS BEEN RESOLVED.

- d. The indoor blower will begin to operate within 30 seconds and remain running.

NOTE: IT IS NORMAL FOR THE INDOOR BLOWER TO RAMP UP OR DOWN DURING THIS TEST.

NOTE: IF A COMMUNICATING THERMOSTAT IS INSTALLED, A LOSS OF COMMUNICATIONS ERROR CODE MIGHT BE DISPLAYED ON THE THERMOSTAT SCREEN DURING THE TEST. IF THIS DOES NOT HAPPEN, IT IS OKAY TO PROCEED WITH THE TESTING AS LONG AS ALL HVAC OPERATION, OTHER THAN THE BLOWER, WERE CONFIRMED TO TURN OFF DURING THIS TEST.

- e. Once steps C and D have been confirmed, the test was successful. Reconnect the R32 sensor. The on-board LED will turn solid on once the sensor is detected and the system will remain in this mode for 5 minutes before exiting.

NOTE: POWER CYCLING THE SYSTEM WILL BYPASS THIS 5 MINUTE DELAY PERIOD.

- f. Wait for the system to return to the state it was

in after the first step, to confirm the system will automatically recover, and then repeat the tests using the other HVAC modes not previously tested. It is extremely important to verify the Non-A2L Furnace Integration Kit will function properly for all modes of operation.

NOTE: IF THE NON-A2L FURNACE INTEGRATION KIT IS NOT FUNCTIONING PROPERLY FOR ANY OF THE MODES, PLEASE RE-CHECK THE WIRING DIAGRAM FOR YOUR INSTALLED SYSTEM AND DO NOT CONTINUE UNTIL THE ISSUE HAS BEEN RESOLVED.

R-32 LEAK MITIGATION PERFORMANCE

NOTE: If a R-32 leak is detected, the Non-A2L Furnace Integration Kit control will automatically enter R-32 Mitigation mode. R-32 Mitigation mode provides the same performance as seen during the test mode. The Non-A2L Furnace Integration Kit will ensure all HVAC system functionality (Heating and Cooling) is off and the indoor blower is running. After the R-32 sensor no longer detects refrigerant, the system will remain in mitigation mode for an additional 5 minutes. During this 5-minute period the red LED will change from a rapid flashing pattern to being continuously on. After 5 minutes, the Non-A2L Furnace Integration Kit will allow the system to return to normal operation and the red LED will start a slow flashing pattern again (2 seconds on and 2 seconds off).

A2L STATUS CODES

RED LED'S STATUS					
	MODE	Definition	LED Flashing Pattern	Recommended actions	Notes:
1	Normal Operation	No faults to report	Slow LED flashing pattern (2 seconds on and 2 seconds off)	No action	
2	R-32 Leak Alarm	R-32 leak is currently being detected	Fast LED Flashing Pattern	The controls and sensor are working properly. Identify where the leak is coming from and address the leak.	
3	Delay Mode	After R-32 leak or Alarm has been cleared, the unit will remain in alarm mode for 5 minutes before returning to normal operation	LED will be on continuously	Check HVAC performance (Cooling and Heating Modes). Check system pressures and lines for any leaks. Re-Check HVAC performance after addressing any issues.	After any alarm or fault, it is required to remain in R-32 mitigation mode for 5 minutes.
4	System Verification Mode	Manual test run by contractor to simulate R-32 Leak Alarm (test will last for 5 minutes max)	Fast LED Flashing Pattern	No actions needed	To Enter system verification test mode, press the button on the control 2 times within 5 seconds. The control will enter a simulated R-32 Leak Alarm state and remain in that mode for 5 minutes. After 5 minutes, the control will return to Normal Operation automatically. If the contractor wants to end the test early they need to press the button one time.
5	Control Board Internal Fault	Control board has detected an issue with the R-32 detection system	LED will flash 2 times and then be off for 5 seconds before repeating the pattern	<ol style="list-style-type: none"> 1) Unplug and plug the R-32 sensor back in. Cycle power to the system. 2) If control is in Normal Operation or Delay mode, there is no more issue. If not, continue with diagnostics 3) Unplug R-32 sensor and leave unplugged. Cycle power to the system 4) If control still displays "Control Board Internal Fault" (2 flash pattern) replace the control. If control now displays "R-32 Sensor Communication Fault" (3 flash pattern) replace the sensor. 	These steps will determine if the error is on the board or external to the board.
6	R-32 Sensor Communication Fault	Control board does not have communications with R-32 sensor	LED will flash 3 times and then be off for 5 seconds before repeating the pattern	<ol style="list-style-type: none"> 1) Unplug and plug the R-32 sensor back in. Cycle power to the system. 2) If control is in Normal Operation or Delay mode, there is no more issue. If not, continue with diagnostics 3) If control still displays "R-32 Sensor Communication Fault" (3 flash pattern), Relace both the sensor and the PCB, 	If the control cannot talk to the sensor there could be a problem with the sensor, a problem with the sensor harness or a problem internal to the control. The field will not be able to measure anything to reliably fix this error assuming the connector is properly secured to the control. Replacing both is the only option.
7	R-32 Sensor Fault	R-32 Sensor has reported an internal issue	LED will blink 4 times and then be off for 5 seconds before repeating the pattern	<ol style="list-style-type: none"> 1) Unplug and plug the R-32 sensor back in. Cycle power to the system. 2) If control is in Normal Operation or Delay mode, there is no more issue. If not, continue with diagnostics 3) If control still displays "R-32 Sensor Fault" (4 flash pattern), Relace both the sensor. 	This means communications to the sensor are perfectly fine. The sensor itself is reporting an internal fault.

BEFORE STARTING INSTALLATION, PLEASE FAMILIARIZE YOURSELF WITH THE TERMINALS ON THE INTEGRATION KIT AND THE BLOCK DIAGRAMS BELOW.

Vt_In and Vt_Out terminals are intended to be used as a low voltage signal to turn on any installed ventilator if an R32 leak is detected (24VAC at 1A max).

The Alarm output is only to be used with specific A2L accessories. Wiring instructions for using this terminal will be detailed in the installation manuals of these other accessory products. Do not use this terminal unless specifically instructed to.

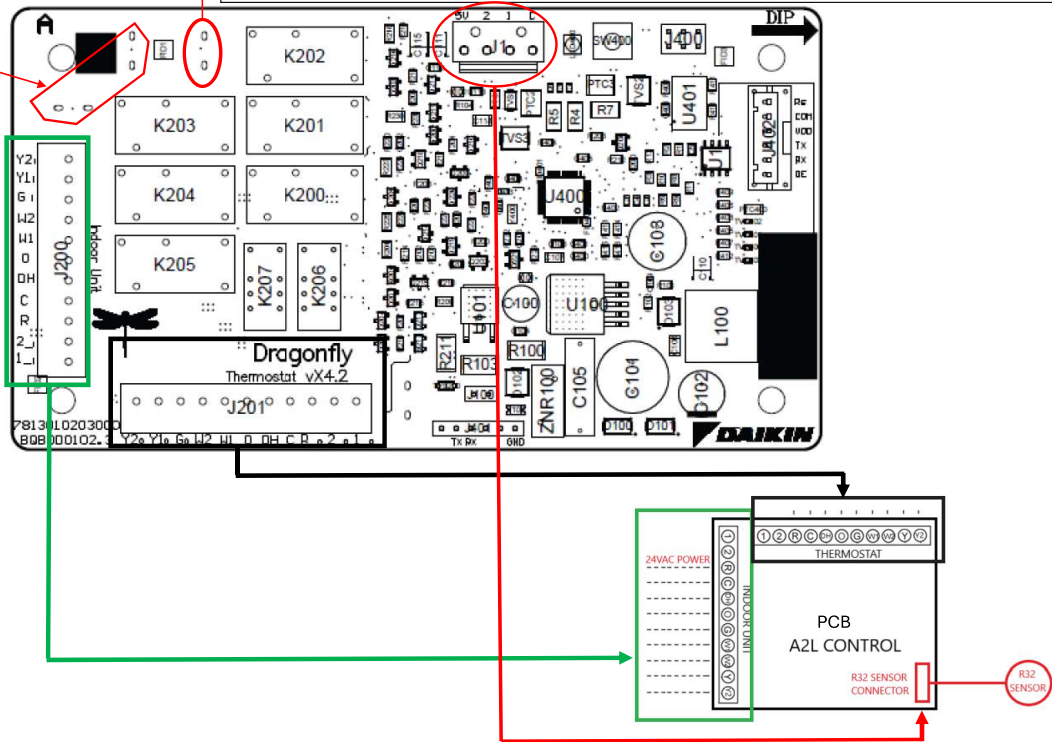

Check that all the cabling will not be subject to wear, corrosion, excessive pressure, vibration, sharp edges or any other adverse environmental effects. The check shall also take into account the effects of aging or continual vibration from sources such as furnace blower or modular blower.

WIRING FOR VARIOUS CONTROL SYSTEMS

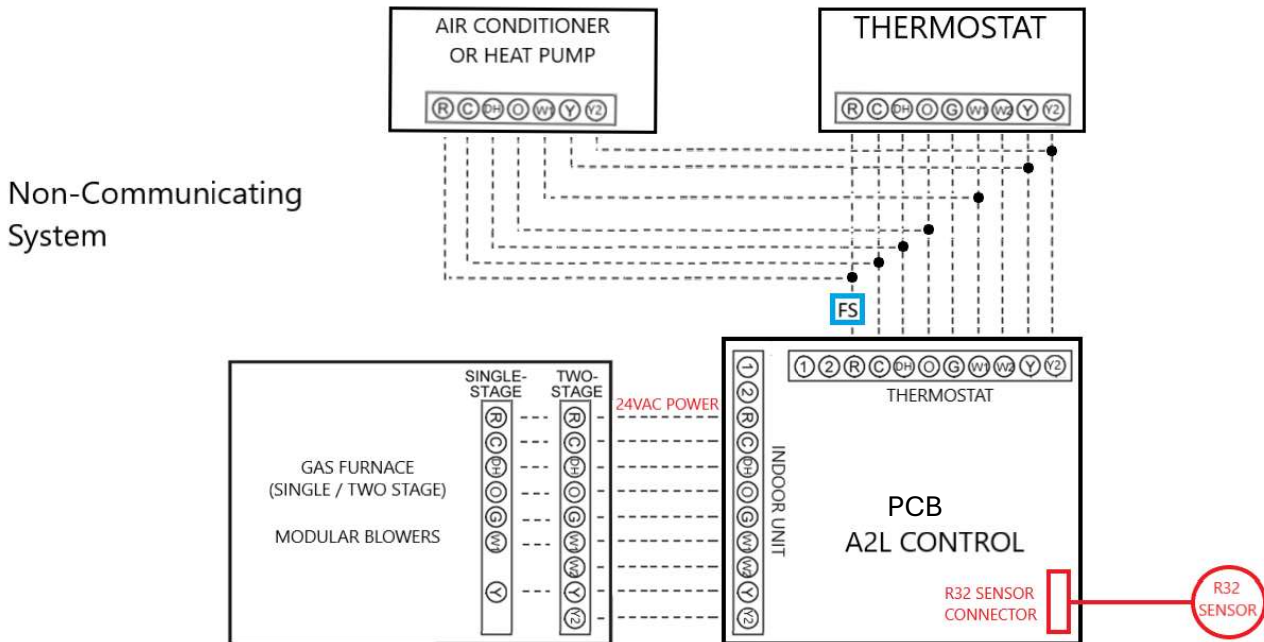

Note: For installs using a Float Switch (FS), install in series with R wire to the thermostat.
 Note: For Single Stage outdoor units, the Y2 wire is not required between the furnace and non-A2L Furnace Integration Kit

WIRING FOR VARIOUS CONTROL SYSTEMS

ComfortBridge Communicating System

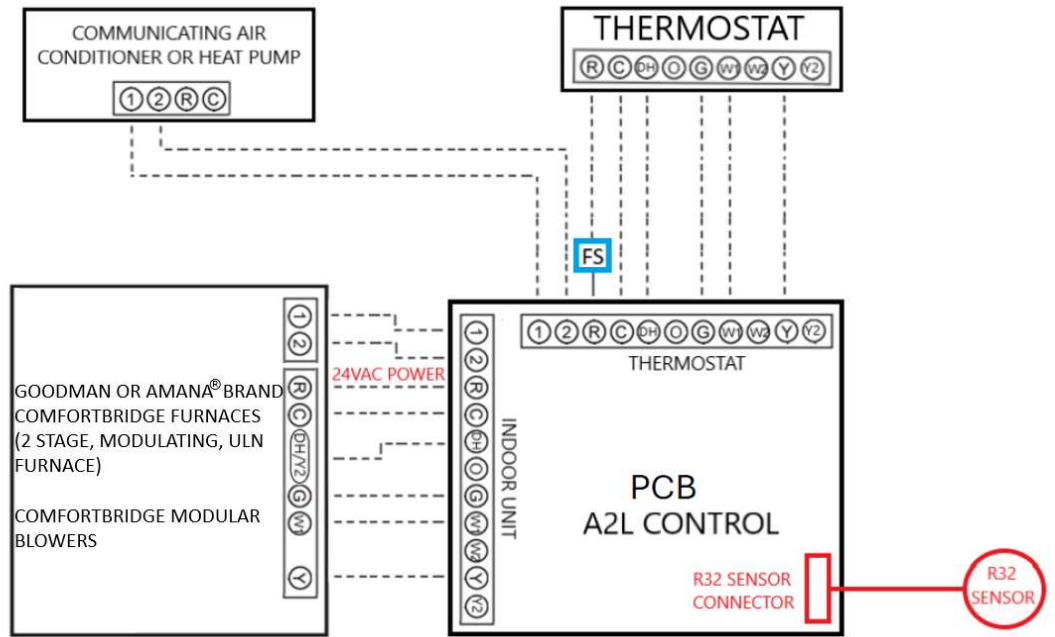

Note: For installs using a Float Switch (FS), install in series with R wire to the thermostat.

ComfortBridge Non-Communicating System

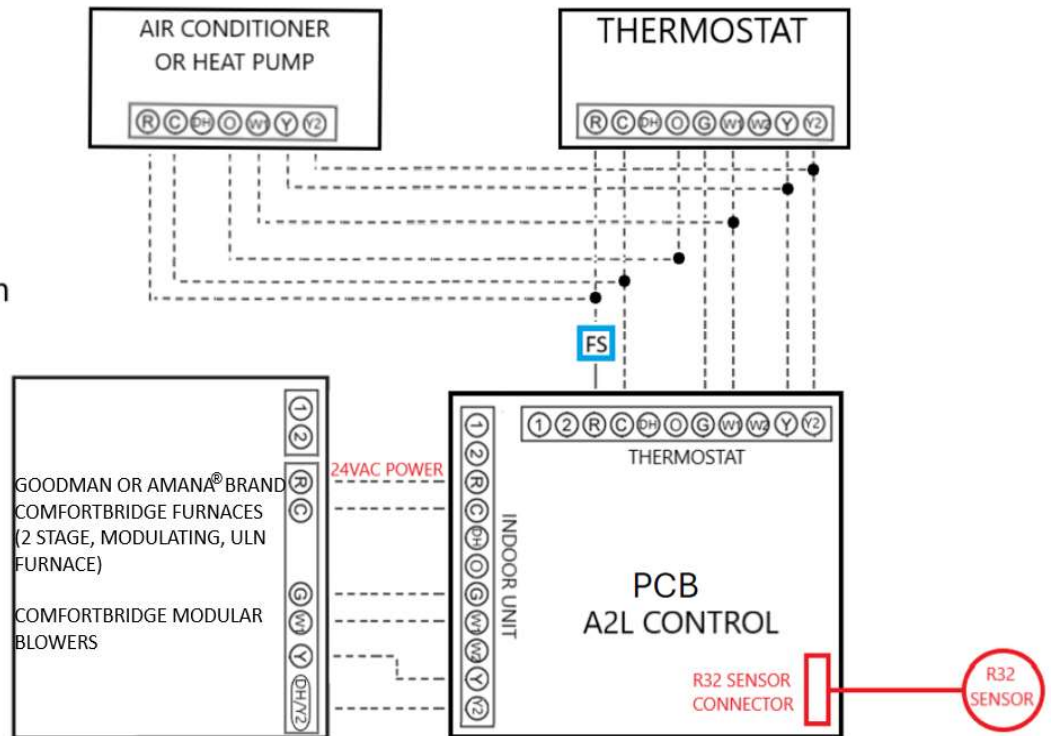

Note: For installs using a Float Switch (FS), install in series with R wire to the thermostat.

Note: For Single Stage outdoor units, the Y2 wire is not required between the furnace and non-A2L Furnace Integration Kit. Instead, the DH/Y2 terminal on the ComfortBridge control can be used for dehumidification purposes if required.

WIRING FOR VARIOUS CONTROL SYSTEMS

ComfortNet
Communicating
system with EEV
Coil

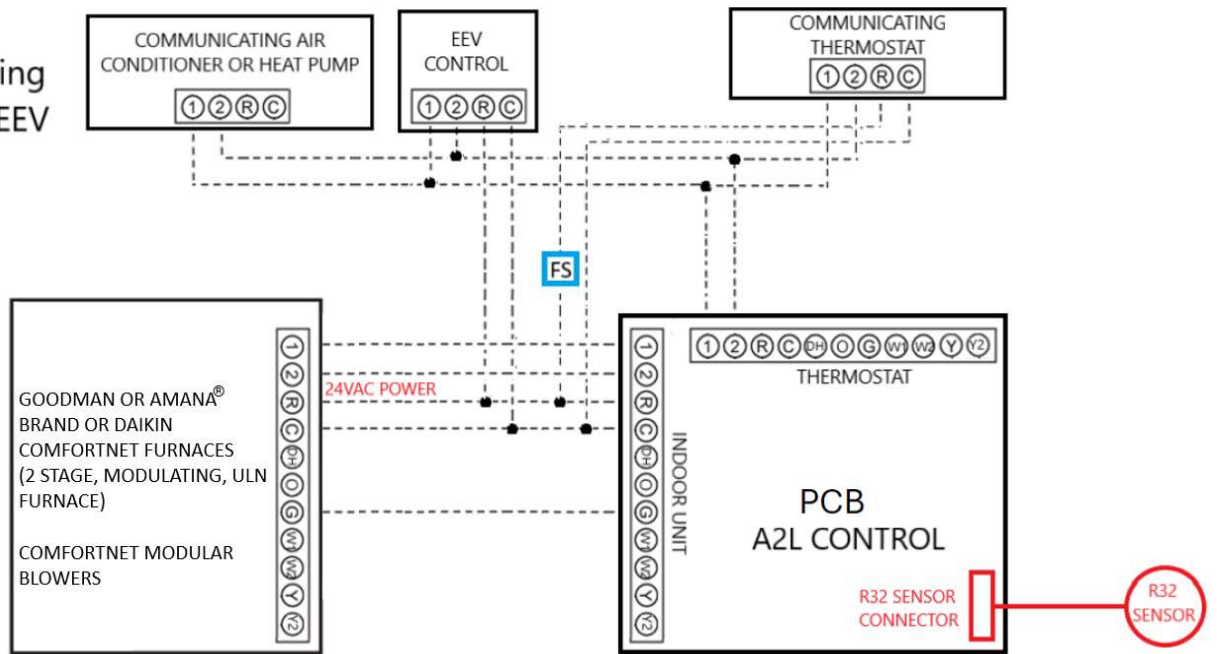

Note: For installs using a Float Switch (FS), install in series with R wire to the thermostat.

ComfortNet
Communicating
System

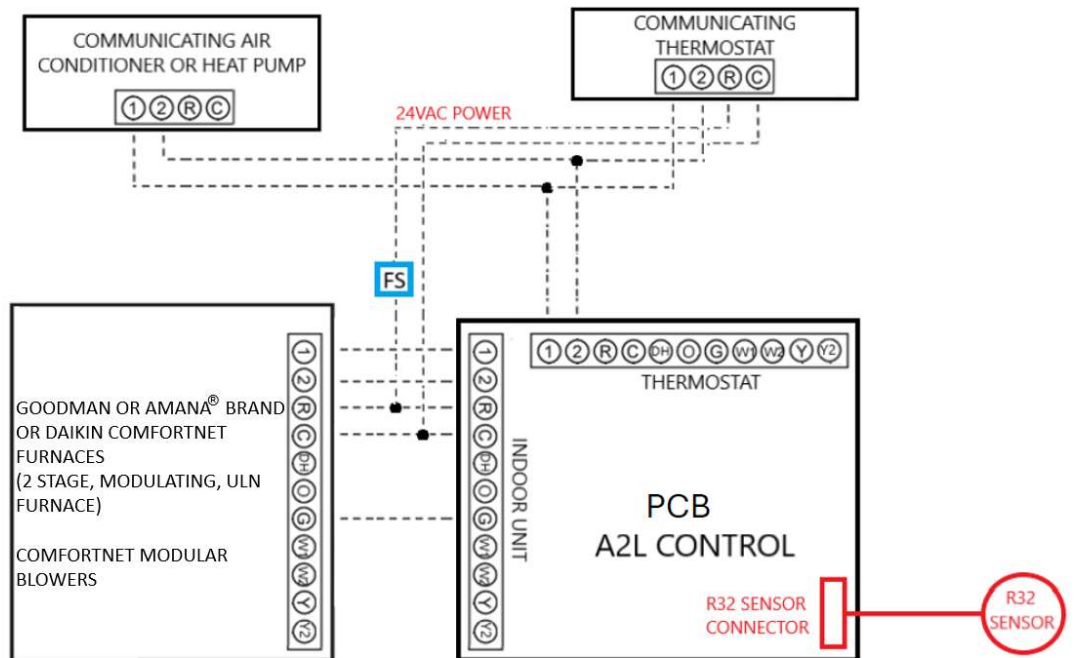

Note: For installs using a Float Switch (FS), install in series with R wire to the thermostat.

WIRING FOR VARIOUS CONTROL SYSTEMS

ComfortNet Mixed Mode System

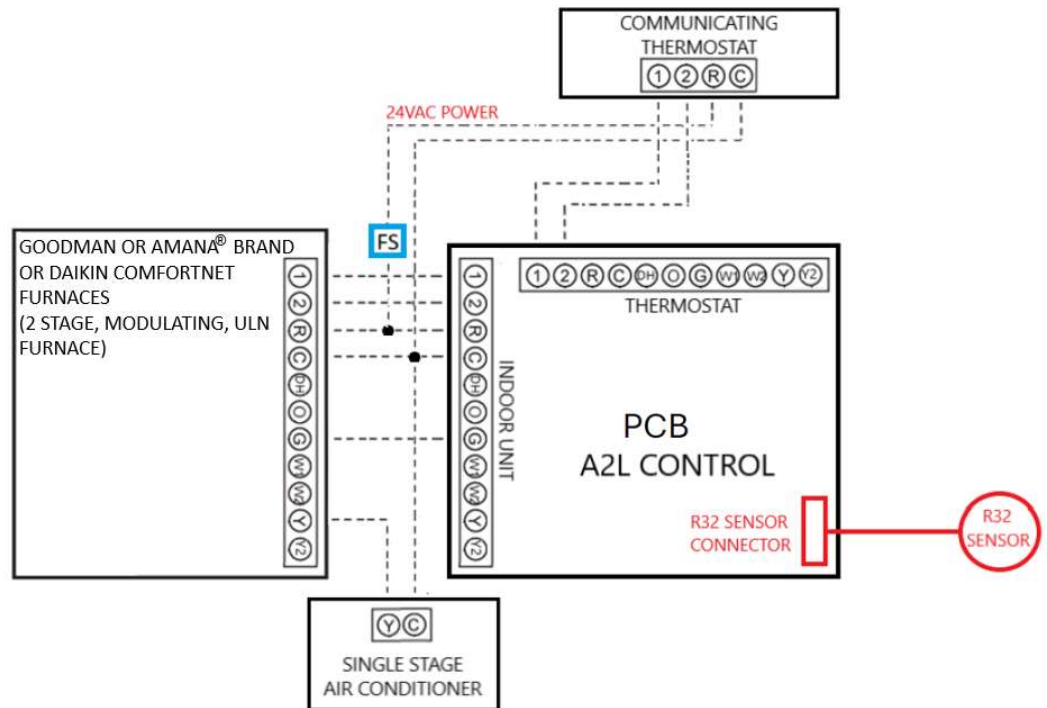

Note: For installs using a Float Switch (FS), install in series with R wire to the thermostat.

ComfortNet Non-Communicating System

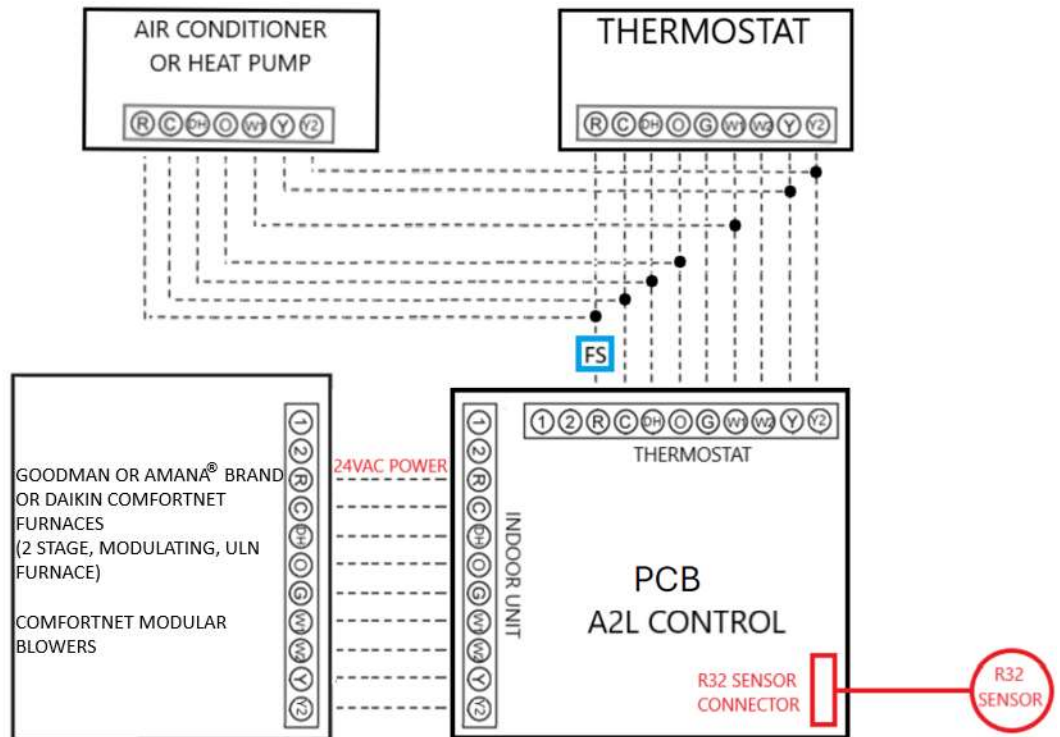

Note: For installs using a Float Switch (FS), install in series with R wire to the thermostat.

CUSTOMER FEEDBACK

We are very interested in all product comments.

Please fill out the feedback form on one of the following links:

Daikin Products: (<https://daikincomfort.com/contact-us>)

Goodman® Brand Products: (<http://www.goodmanmfg.com/about/contact-us>).

Amana® Brand Products: (<http://www.amana-hac.com/about-us/contact-us>).

You can also scan the QR code on the right for the product brand you purchased to be directed to the feedback page.



DAIKIN



GOODMAN® BRAND



AMANA® BRAND

19001 Kermier Rd., Waller, TX 77484

www.daikincomfort.com • www.goodmanmfg.com • www.amana-hac.com

© 2024-2025 Daikin Comfort Technologies Manufacturing, L.P.

Amana is a registered trademark of Maytag Corporation or its related companies and is used under license. All rights reserved.