

# ARUF\*\*14\*\* / ASPT\*\*14\*\* AIR HANDLERS INSTALLATION & OPERATING INSTRUCTIONS

© 2014-2018, 2020-2023  
Daikin Comfort Technologies Manufacturing, L.P.  
19001 Kermier Rd., Waller, TX 77484  
www.goodmanmfg.com -or- www.amana-hac.com  
P/N: IO-901N Date: April 2023

## TABLE OF CONTENTS

<b>1 Important Safety Instructions</b> .....	1
<b>2 Shipping Inspection</b> .....	3
2.1 Parts.....	3
2.2 Handling.....	3
<b>3 Codes &amp; Regulations</b> .....	3
<b>4 Replacement Parts</b> .....	3
<b>5 Pre-Installation Considerations</b> .....	3
5.1 Preparation.....	3
5.2 System Matches.....	3
5.3 Interconnecting Tubing.....	3
5.4 Clearances.....	3
5.5 Horizontal Applications.....	3
5.6 Access.....	4
<b>6 Installation Location</b> .....	4
6.1 Upflow Installation.....	4
6.2 Horizontal Left Installation.....	4
6.3 Horizontal Right Installation / Downflow Installation.....	5
<b>7 Refrigerant Lines</b> .....	6
7.1 Tubing Size.....	6
7.2 Tubing Preparation.....	6
7.3 Special Instructions.....	6
7.4 Tubing Connections for Flowrator Model.....	8
7.5 Tubing Connections for TXV Models.....	8
7.6 ASPT**14** Models with Non-Adjustable TXV.....	8
7.7 Thermal Expansion Valve System Adjustment.....	9
<b>8 Condensate Drain Lines</b> .....	10
<b>9 Ductwork</b> .....	10
9.1 Return Ductwork.....	11
<b>10 Return Air Filters</b> .....	11
<b>11 Electric Heat</b> .....	11
<b>12 Electrical and Control Wiring</b> .....	12
12.1 Building Electrical Service Inspect.....	12
12.2 Wire Sizing.....	12
12.3 Maximum Overcurrent Protection (MOP).....	12
12.4 Electrical Connections – Supply Voltage.....	14
12.4.1 Air Handler Only (Non-Heat Kit Models).....	14
12.4.2 Air Handler - Non-Circuit Breaker Heat Kits	14



## WARNING

**ONLY PERSONNEL THAT HAVE BEEN TRAINED TO INSTALL, ADJUST, SERVICE, MAINTENANCE OR REPAIR (HEREINAFTER, "SERVICE") THE EQUIPMENT SPECIFIED THIS MANUAL SHOULD SERVICE THE EQUIPMENT.**

**THIS EQUIPMENT IS NOT INTENDED FOR USE BY PERSONS (INCLUDING CHILDREN) WITH REDUCED PHYSICAL, SENSORY OR MENTAL CAPACITIES, OR LACK OF EXPERIENCE AND KNOWLEDGE, UNLESS THEY HAVE BEEN GIVEN SUPERVISION OR INSTRUCTION CONCERNING USE OF THE APPLIANCE BY A PERSON RESPONSIBLE FOR THEIR SAFETY.**

**CHILDREN SHOULD BE SUPERVISED TO ENSURE THAT THEY DO NOT PLAY WITH THE EQUIPMENT.**

**THE MANUFACTURER WILL NOT BE RESPONSIBLE FOR ANY INJURY OR PROPERTY DAMAGE ARISING FROM IMPROPER SUPERVISION, SERVICE OR SERVICE PROCEDURES. IF YOU SERVICE THIS UNIT, YOU ASSUME RESPONSIBILITY FOR ANY INJURY OR PROPERTY DAMAGE WHICH MAY RESULT. IN ADDITION, IN JURISDICTIONS THAT REQUIRE ONE OR MORE LICENSES TO SERVICE THE EQUIPMENT SPECIFIED IN THIS MANUAL, ONLY LICENSED PERSONNEL SHOULD SERVICE THE EQUIPMENT. IMPROPER SUPERVISION, INSTALLATION, ADJUSTMENT, SERVICING, MAINTENANCE OR REPAIR OF THE EQUIPMENT SPECIFIED IN THIS MANUAL, OR ATTEMPTING TO INSTALL, ADJUST, SERVICE OR REPAIR THE EQUIPMENT SPECIFIED IN THIS MANUAL WITHOUT PROPER SUPERVISION OR TRAINING MAY RESULT IN PRODUCT DAMAGE, PROPERTY DAMAGE, PERSONAL INJURY OR DEATH.**

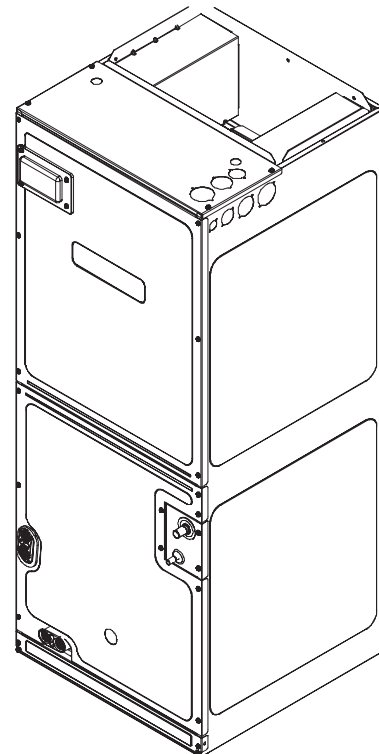

## WARNING

**DO NOT BYPASS SAFETY DEVICES.**





## RECOGNIZE THIS SYMBOL AS A SAFETY PRECAUTION

NOTE: SPECIFICATIONS AND PERFORMANCE DATA LISTED HEREIN ARE SUBJECT TO CHANGE WITHOUT NOTICE



12.4.3 Air Handler With Circuit Breaker Heat Kit ...	14
12.5 Low Voltage Connections .....	14
12.5.1 Thermostats .....	14
12.6 Speed Tap Adjustment.....	14
<b>13 Achieving 1.4% Low Leakage Rate .....</b>	<b>15</b>
<b>14 Start-Up Procedure.....</b>	<b>15</b>
<b>15 Regular Maintenance .....</b>	<b>15</b>
<b>16 Airflow Data.....</b>	<b>16</b>
<b>17 Air Handler Low Voltage Connections.....</b>	<b>18</b>
<b>18 Wiring Diagrams .....</b>	<b>19</b>
<b>19 Start-Up Checklist .....</b>	<b>27</b>



	<b>WARNING</b>
<b>HIGH VOLTAGE</b>	
DISCONNECT ALL POWER BEFORE SERVICING OR INSTALLING THIS UNIT. MULTIPLE POWER SOURCES MAY BE PRESENT. FAILURE TO DO SO MAY CAUSE PROPERTY DAMAGE, PERSONAL INJURY OR DEATH.	
	

	<b>WARNING</b>
TO PREVENT THE RISK OF PROPERTY DAMAGE, PERSONAL INJURY, OR DEATH, DO NOT STORE COMBUSTIBLE MATERIALS OR USE GASOLINE OR OTHER FLAMMABLE LIQUIDS OR VAPORS IN THE VICINITY OF THIS UNIT.	

	<b>WARNING</b>
THIS PRODUCT IS FACTORY-SHIPED FOR USE WITH 208/240/1/60 ELECTRICAL POWER SUPPLY. <b>Do NOT</b> RECONFIGURE THIS AIR HANDLER TO OPERATE WITH ANY OTHER POWER SUPPLY.	

	<b>CAUTION</b>
WHEN INSTALLING OR SERVICING THIS EQUIPMENT, SAFETY CLOTHING, INCLUDING HAND AND EYE PROTECTION, IS STRONGLY RECOMMENDED. IF INSTALLING IN AN AREA THAT HAS SPECIAL SAFETY REQUIREMENTS (HARD HATS, ETC.), OBSERVE THESE REQUIREMENTS.	

	<b>WARNING</b>
TO AVOID PROPERTY DAMAGE, PERSONAL INJURY OR DEATH DUE TO ELECTRICAL SHOCK, THIS UNIT <b>MUST</b> HAVE AN <b>UNINTERRUPTED, UNBROKEN</b> ELECTRICAL GROUND. THE ELECTRICAL GROUND CIRCUIT MAY CONSIST OF AN APPROPRIATELY SIZED ELECTRICAL WIRE CONNECTING THE GROUND LUG IN THE UNIT CONTROL BOX TO THE BUILDING ELECTRICAL SERVICE PANEL. OTHER METHODS OF GROUNDING ARE PERMITTED IF PERFORMED IN ACCORDANCE WITH THE NATIONAL ELECTRIC CODE (NEC)/ AMERICAN NATIONAL STANDARDS INSTITUTE (ANSI)/NATIONAL FIRE PROTECTION ASSOCIATION (NFPA) 70 AND LOCAL/STATE CODE. IN CANADA, ELECTRICAL GROUNDING IS TO BE IN ACCORDANCE WITH THE CANADIAN ELECTRIC CODE (CSA) C22.1.	

	<b>DANGER PELIGRO</b>
	
<b>CARBON MONOXIDE POISONING HAZARD</b>	
Special Warning for Installation of Furnace or Air Handling Units in Enclosed Areas such as Garages, Utility Rooms or Parking Areas	
Carbon monoxide producing devices (such as an automobile, space heater, gas water heater, etc.) should not be operated in enclosed areas such as unventilated garages, utility rooms or parking areas because of the danger of carbon monoxide (CO) poisoning resulting from the exhaust emissions. If a furnace or air handler is installed in an enclosed area such as a garage, utility room or parking area and a carbon monoxide producing device is operated therein, there must be adequate, direct outside ventilation.	
This ventilation is necessary to avoid the danger of CO poisoning which can occur if a carbon monoxide producing device continues to operate in the enclosed area. Carbon monoxide emissions can be (re)circulated throughout the structure if the furnace or air handler is operating in any mode.	
CO can cause serious illness including permanent brain damage or death.	B10259-216
<b>RIESGO DE INTOXICACIÓN POR MONÓXIDO DE CARBONO</b>	
Advertencia especial para la instalación de calentadores ó amañejadoras de aire en áreas cerradas como estacionamientos ó cuartos de servicio.	
Los equipos ó aparatos que producen monóxido de carbono (tal como automóvil, calentador de gas, calentador de agua por medio de gas, etc) no deben ser operados en áreas cerradas debido al riesgo de envenenamiento por monóxido de carbono (CO) que resulta de las emisiones de gases de combustión. Si el equipo ó aparato se opera en dichas áreas, debe existir una adecuada ventilación directa al exterior. Esta ventilación es necesaria para evitar el peligro de envenenamiento por CO, que puede ocurrir si un dispositivo que produce monóxido de carbono sigue operando en el lugar cerrado. Las emisiones de monóxido de carbono pueden circular a través del aparato cuando se opera en cualquier modo.	
El monóxido de carbono puede causar enfermedades severas como daño cerebral permanente ó muerte.	B10259-216
<b>RISQUE D'EMPOISONNEMENT AU MONOXYDE DE CARBONE</b>	
Avertissement special au sujet de l'installation d'appareils de chauffage ou de traitement d'air dans des endroits clos, tels les garages, les locaux d'entretien et les stationnements.	
Evitez de mettre en marche les appareils produisant du monoxyde de carbone (tels que les automobile, les appareils de chauffage autonome, etc.) dans des endroits non ventilés tels que les d'empoisonnement au monoxyde de carbone. Si vous devez faire fonctionner ces appareils dans un endroit clos, assurez-vous qu'il y ait une ventilation directe provenant de l'exterieur.	
Cette ventilation est nécessaire pour éviter le danger d'intoxication au CO pouvant survenir si un appareil produisant du monoxyde de carbone continue de fonctionner au sein de la zone confinée.	
Les émissions de monoxyde de carbone peuvent être recirculées dans les endroits clos, si l'appareil de chauffage ou de traitement d'air sont en marche.	
Le monoxyde de carbone peut causer des maladies graves telles que des dommages permanents au cerveau et même la mort.	B10259-216

## 1 Important Safety Instructions

The following symbols and labels are used throughout this manual to indicate immediate or potential safety hazards. It is the owner's and installer's responsibility to read and comply with all safety information and instructions accompanying these symbols. Failure to heed safety information increases the risk of personal injury, property damage, and/or product damage.

## 2 Shipping Inspection

Always transport the unit upright; laying the unit on its side or top during transit may cause equipment damage. The installer should inspect the product upon receipt for shipping damage and subsequent investigation is the responsibility of the carrier. The installer must verify the model number, specifications, electrical characteristics, and accessories are correct prior to installation. The distributor or manufacturer will not accept claims from dealers for transportation damage or installation of incorrectly shipped units.

### 2.1 Parts

Also inspect the unit to verify all required components are present and intact. Report any missing components immediately to the manufacturer or to the distributor. Use only factory authorized replacement parts (see Section 5). Make sure to include the full product model number and serial number when reporting and/or obtaining service parts.

### 2.2 Handling

Use caution when transporting / carrying the unit. Do not move unit using shipping straps. Do not carry unit with hooks or sharp objects. The preferred method of carrying the unit after arrival at the job site is to carry via a two-wheel hand truck from the back or sides or via hand by carrying at the cabinet corners.

## 3 Codes & Regulations

This product is designed and manufactured to comply with applicable national codes. Installation in accordance with such codes and / or prevailing local codes / regulations is the responsibility of the installer. The manufacturer assumes no responsibility for equipment installed in violation of any codes or regulations.

**The United States Environmental Protection Agency (EPA) has issued various regulations regarding the introduction and disposal of refrigerants. Failure to follow these regulations may harm the environment and can lead to the imposition of substantial fines.** Should you have any questions please contact the local office of the EPA and / or refer to EPA's website [www.epa.gov](http://www.epa.gov).

## 4 Replacement Parts

When reporting shortages or damages, or ordering repair parts, give the complete product model and serial numbers as stamped on the product. Replacement parts for this product are available through your contractor or local distributor. For the location of your nearest distributor consult the white business pages, the yellow page section of the local telephone book or contact:

## 5 Pre-Installation Considerations

### 5.1 Preparation

Keep this document with the unit. Carefully read all instructions for the installation prior to installing product. Make sure each step or procedure is understood and any special considerations are taken into account before starting installation. Assemble all tools, hardware and supplies needed to complete the installation. Some items may need to be purchased locally. Make sure everything needed to install the product is on hand before starting.

### 5.2 System Matches

The entire system (combination of indoor and outdoor sections) must be manufacturer approved and Air-Conditioning, Heating, and Refrigeration Institute (AHRI) listed. **NOTE:** Installation of unmatched systems is not permitted.

### 5.3 Interconnecting Tubing

Give special consideration to minimize the length of refrigerant tubing when installing air handlers. Refer to Remote Cooling / Heat Pump Service Manual RS6200006, and TP-107 Long Line Set Application R-410A for tubing guidelines. If possible, allow adequate length of tubing such that the coil may be removed (for inspection or cleaning services) from the cabinet without disconnecting the tubing.

### 5.4 Clearances

The unit clearance from a combustible surface may be 0". However, service clearance must take precedence. A minimum of 24" in front of the unit for service clearance is required. Additional clearance on one side or top will be required for electrical wiring connections. Consult all appropriate regulatory codes prior to determining final clearances. When installing this unit in an area that may become wet (such as crawl spaces), elevate the unit with a sturdy, non-porous material. In installations that may lead to physical damage (i.e. a garage) it is advised to install a protective barrier to prevent such damage. Always install units such that a positive slope in condensate line (1/4" per foot) is allowed.

### 5.5 Horizontal Applications

If installed above a finished living space, a secondary drain pan (as required by many building codes), must be installed under the entire unit and its condensate drain line must be routed to a location such that the user will see the condensate discharge.

## 5.6 Access

This unit should be installed in a manner so that it is not accessible to the public.

## 6 Installation Location

**NOTE:** These air handlers are designed for indoor installation only at a max altitude of 10,500 feet above sea level or a min altitude of -184 feet below sea level.

If the unit is located in an unconditioned area with high ambient temperature and/or high humidity, the air handler may be subject to nuisance sweating of the casing. On these installations, a wrap of 2" fiberglass insulation with a vapor barrier is recommended. A secondary drain pan below the unit is also recommended to protect the installation site.

This product line may be installed in one of the upflow, downflow, horizontal left or horizontal right orientations as shown in Figures 2, 3, 4 and 5. The unit may be installed in horizontal left orientation as shipped (refer to specific sections for more information).

### 6.1 Upflow and Downflow Installation (Figure 2 & 3)

1. Remove blower access panel and coil access panel. The coil access panel and tubing panel may remain screwed together during this procedure. Remove and retain the seven (7) screws securing the coil access panel to the cabinet and the six (6) screws securing the blower access panel to the cabinet.

2. Slide the coil assembly out from the cabinet. Use the drain pan to pull the assembly from the cabinet.

**IMPORTANT:** Do not use manifolds, copper lines, or the flowrator to pull the coil assembly out. Failure to do so may result in braze joint damage and leaks.

3. Removal of the center support is required on units with 21" wide cabinet. Remove and retain the two (2) screws that secure the center support to the cabinet. Remove the center support.

4. **The horizontal drip shield, side drain pan, and drain pan extension must be removed. Follow the "Side Drain Pan and Extension Removal Instructions".**

#### 5. For Upflow Installation:

- Using the drain pan to hold the coil assembly, slide the coil assembly back into the cabinet.
- Reinstall the center support (if removed) using the two (2) screws removed in Step 3.
- Reinstall the coil access panels and reinstall blower access panel removed in Step 1 as shown in Figure 8.

#### 6. For Downflow Installation:

- Position the unit in the downflow position.
- Using the drain pan to hold the coil assembly, slide the coil assembly back into the cabinet on the downflow brackets as shown in Figure 8.
- Reinstall the center support (if removed) using the two (2) screws removed in Step 3.
- Reinstall the coil access panels and reinstall blower access panel removed in Step 1 as shown in Figure 9.

## Side Drain Pan and Extension Removal Instructions

Refer to Figure 1, remove the two (2) screws that secure the drip shield support brackets to the condensate collectors (front and back). Unsnap the side drain pan from the bottom drain pan using a screwdriver or any small lever. The side drain pan, drip shield brackets and the drain pan extension may now be removed. From Figure 1, drain port labeled (A) is the primary drain for this application and condensate drain line must be attached to this drain port. Drain port (a) is for the secondary drain line (if used). When the side drain pan is removed, the drain port opening in the access panel must be covered by the accessory drain port plug (DPK1) as shown in Figure 1.1.

Drain Port Plug		
Kit Number	Description	Application
DPK1	Side Drain Port Plug	All Models

DRAIN PORT PLUG KIT

Table 1

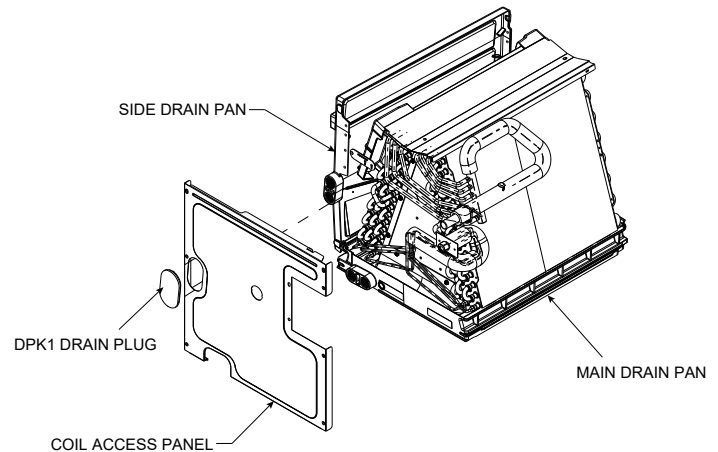

DRAIN PAN

Figure 1.1

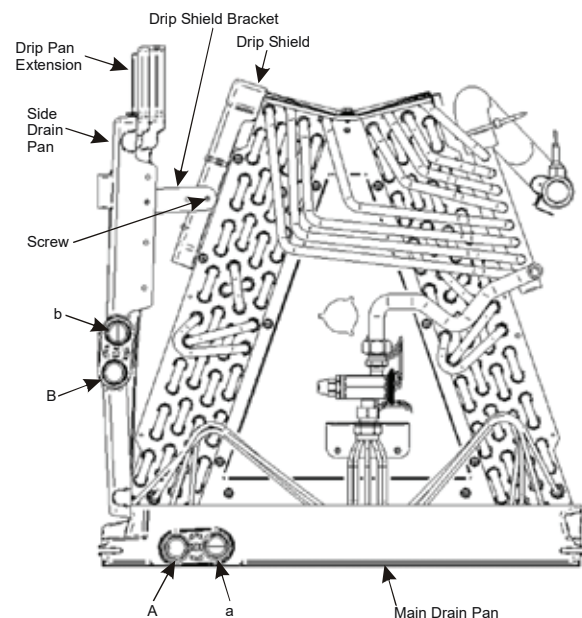

SIDE DRAIN PAN REMOVAL

Figure 1

**6.2 Horizontal Left Installation (Figure 4)**

No field modifications are permissible for this application. Install unit as shown in Figure 4.

Drain port labeled (B) in Figure 1 is the primary drain for this application and condensate drain line must be attached to this drain port. Drain port (b) is for the secondary drain line (if used).

Remove red plugs from side drain pan before connecting condensate drain pipes. Use removed plug to close drain ports on vertical drain pan.

**6.3 Horizontal Right Installation (Figure 5)**

1. Before inverting the air handler, remove blower access panel and coil access panel. The coil access panel and tubing panel may remain screwed together during this procedure. Remove and retain the seven (7) screws securing the coil access panel to the cabinet and the six (6) screws securing the blower access panel to the cabinet.
2. Slide the coil assembly out from the cabinet. Use the drain pan to pull the assembly from the cabinet.
 

**NOTE:** Do not use manifolds, copper lines, or the flowrator to pull the coil assembly out. Failure to do so may result in braze joint damage and leaks.
3. Removal of the center support is required on units with 21" wide cabinet. Remove and retain the two (2) screws that secure the center support to the cabinet. Remove the center support.
4. Position the unit in the downflow position.
5. Remove side drain pan extension in all models except: ARUF47D14\*\*, ARUF61D14\*\*, ASPT61D14\*\*, and ASPT49D14\*\*.
6. Using the drain pan to hold the coil assembly, slide the coil assembly back into the cabinet on the downflow brackets as shown in Figure 7.
7. Reinstall the center support (if removed) using the two (2) screws removed in Step 5.
8. Reinstall the coil access panels and reinstall blower access panel removed in Step 1 as shown in Figure 9.
9. Drain Connections for Horizontal Right Installation
  - a. Drain port labeled (B) in Figure 1 is the primary drain for this application and condensate drain line must be attached to this drain port. Drain port (b) is for the secondary drain line (if used).
  - b. Remove red plugs from side drain pan before connecting condensate drain pipes. Use removed plug to close drain ports on vertical drain pan.

**Horizontal Left Installation - Humid Environments**

In applications where the air handler is installed in the horizontal left position, and the return air environment see humidity levels above 65% relative humidity coupled with total external static levels above 0.5" e.s.p., a condensate kit is available for field application. Kit nomenclature can be found in Table 2.

CMK0008 Condensate Kit	CMK0009 Condensate Kit	CMK0010 Condensate Kit	CMK0011 Condensate Kit	CMK0012 Condensate Kit	CMK0013 Condensate Kit	CMK0014 Condensate Kit
ARUF25B14	ARUF31B14	ARUF37C14	ARUF47D14	ARUF61D14	ASPT33C14	ASPT49C14
ARUF29B14	ASPT29B14	ARUF37D14		ASPT49D14	ASPT39C14	
ASPT25B14	ASPT37B14	ARUF43C14		ASPT61D14		
		ARUF43D14				
		ARUF49C14				
		ARUF49D14				
		ASPT37C14				
		ASPT47C14				
		ASPT47D14				
		ASPT59C14				

CONDENSATE KIT  
Table 2

**Downflow Installation - Humid Environment**

When installing unit in the downflow position the appropriate (DFK) downflow kit is required to prevent "coil pan sweating". The DFK kit is not supplied with the air handler and is available through your local distributor. See Table 3 for the correct DFK and follow the instructions provided for installation.

Refer to Figure 6 and 7 for the location of the components referenced in the following steps.

MODEL LIST FOR DOWNFLOW KIT		
DFK-B DOWNFLOW KIT	DFK-C DOWNFLOW KIT	DFK-D DOWNFLOW KIT
ARUF25B14**	ARUF37C14**	ARUF37D14**
ARUF29B14**	ARUF43C14**	ARUF43D14**
ARUF31B14**	ARUF49C14**	ARUF47D14**
ASPT25B14**	ASPT33C14**	ARUF49D14**
ASPT29B14**	ASPT37C14**	ARUF61D14**
ASPT35B14**	ASPT39C14**	ASPT61D14**
ASPT37B14**	ASPT47C14**	ASPT47D14**
	ASPT49C14**	ASPT49D14**
	ASPT59C14**	

DOWNFLOW KIT  
Table 3

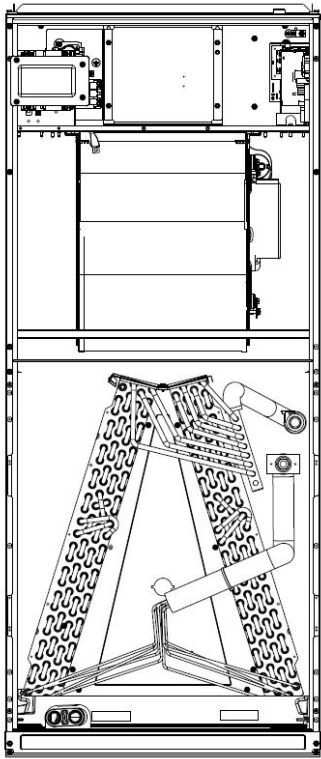

UPFLOW  
Figure 2

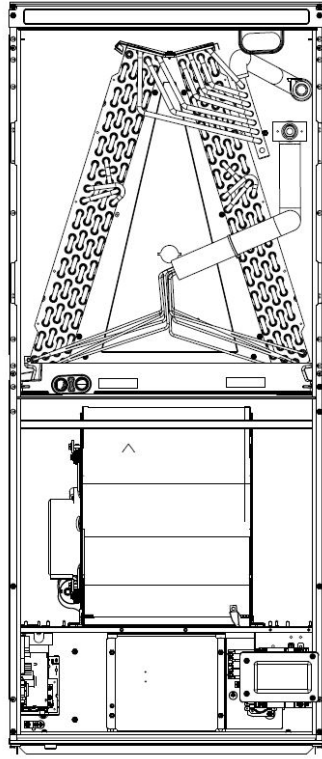

DOWNFLOW  
Figure 3

**NOTE:** Refrigerant tubing must be routed to allow adequate access for servicing and maintenance of the unit.

Do not install the air handler in a location that violates the instructions provided with the condenser. If the unit is located in an unconditioned area with high ambient temperature and/or high humidity, the air handler may be subject to nuisance sweating of the air handler cabinet. On these installations, a wrap of 2" fiberglass insulation with a vapor barrier is recommended.

**7.1 Tubing Size**

For the correct tubing size, follow the specification for the condenser/heat pump.

**7.2 Tubing Preparation**

All cut ends are to be round, burr free, and clean. Failure to follow this practice increases the chances for refrigerant leaks. The suction line is spun closed and requires tubing cutters to remove the closed end.

**NOTE:** To prevent possible damage to the tubing joints, do not handle coil assembly with manifold or flowrator tubes. Always use clean gloves when handling coil assemblies.

**7.3 Special Instructions**

Units without a factory installed TXV come equipped with a flowrator piston for refrigerant expansion. For most installations with matching applications, no change to the flowrator piston is required. However, in mix-matched applications, a flowrator piston change may be required. See the piston kit chart (provided in the literature packet) or consult your local distributor for details regarding mix-matched flowrator piston sizing. If the mix-match application requires a different flowrator piston size, change the flowrator piston in the flowrator body on the indoor coil before installing the coil and use the procedure in section 7.4.

**NOTE:** The use of a heat shield is strongly recommended when brazing to avoid burning the serial plate or the finish of the unit. Heat trap or wet rags must be used to protect heat sensitive components such as service valves and TXV valves sensing bulb.

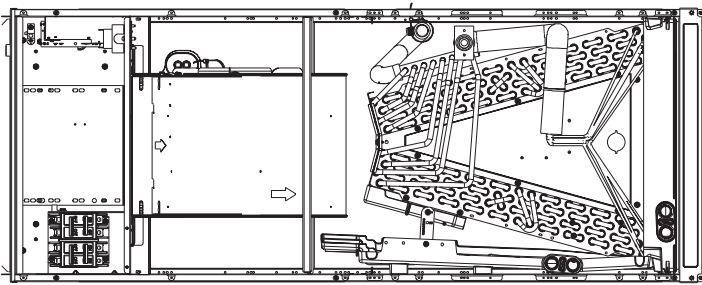

HORIZONTAL LEFT  
Figure 4

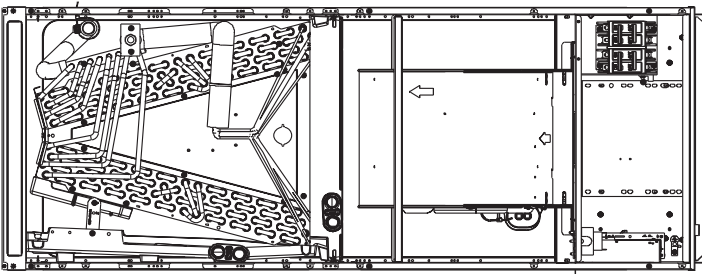

HORIZONTAL RIGHT  
Figure 5

**7 Refrigerant Lines**

	<p><b>WARNING</b></p>
<p>THIS PRODUCT IS FACTORY-SHIPED WITH R410A AND DRY NITROGEN MIXTURE GAS UNDER PRESSURE. USE APPROPRIATE SERVICE TOOLS AND FOLLOW THESE INSTRUCTIONS TO PREVENT INJURY.</p>	

	<p><b>WARNING</b></p>
<p>A QUENCHING CLOTH IS STRONGLY RECOMMENDED TO PREVENT SCORCHING OR MARRING OF THE EQUIPMENT FINISH WHEN BRAZING CLOSE TO THE PAINTED SURFACES. USE BRAZING ALLOY OF 5% MINIMUM SILVER CONTENT.</p>	

	<p><b>CAUTION</b></p>
<p>APPLYING TOO MUCH HEAT TO ANY TUBE CAN MELT THE TUBE. TORCH HEAT REQUIRED TO BRAZE TUBES OF VARIOUS SIZES MUST BE PROPORTIONAL TO THE SIZE OF THE TUBE. SERVICE PERSONNEL MUST USE THE APPROPRIATE HEAT LEVEL FOR THE SIZE OF THE TUBE BEING BRAZED.</p>	

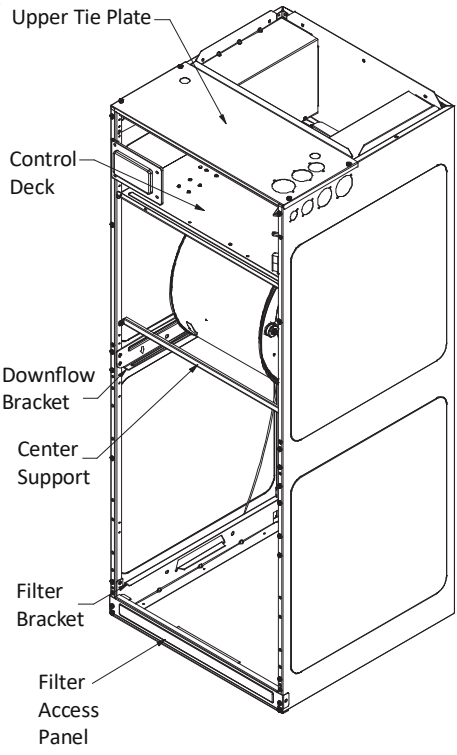

INTERNAL PART TERMINOLOGY

Figure 6

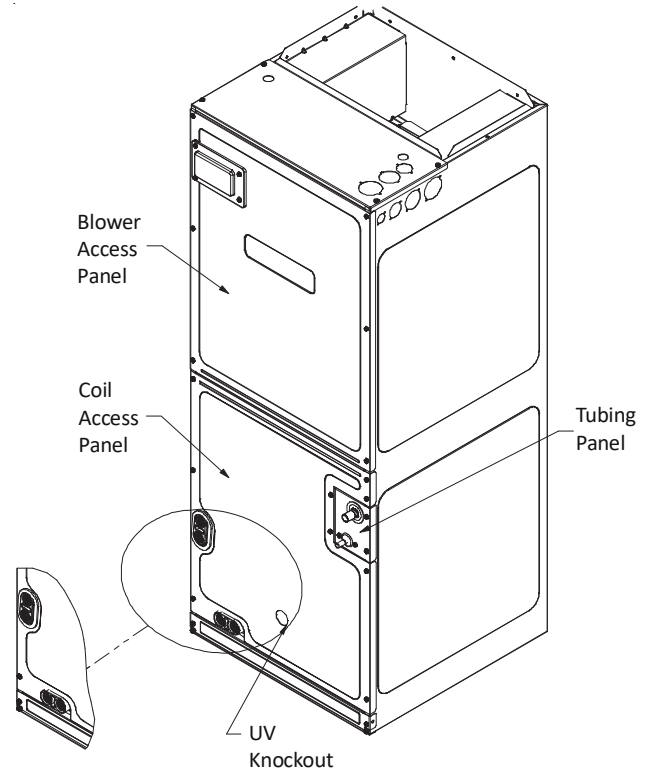

EXTERNAL PART TERMINOLOGY

Figure 7

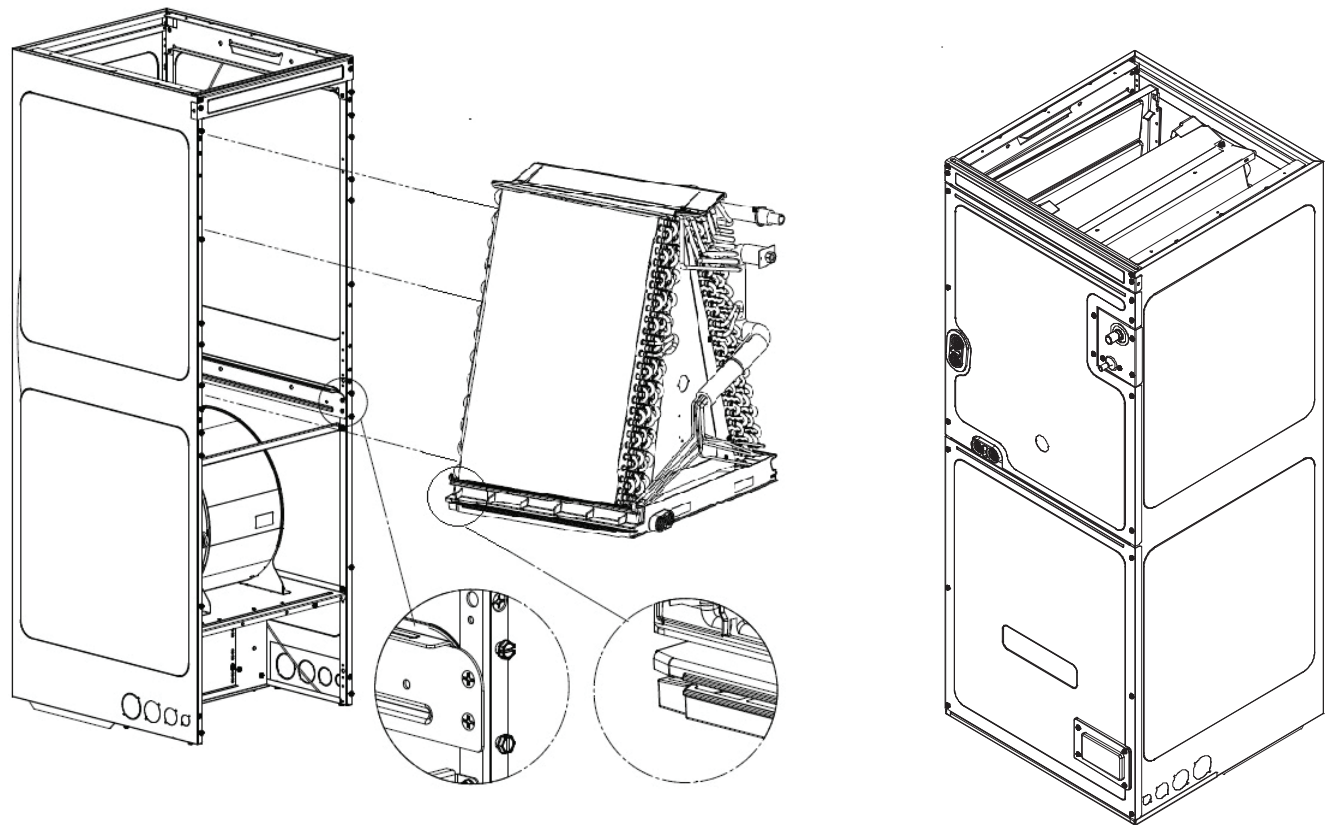

**IMPORTANT NOTE:**  
 Ensure coil slides on the rails along the groove provided on the drain pan side walls. Failure to do so will result in improper condensate drainage.

COIL INSTALLATION FOR DOWNFLOW

Figure 8

ACCESS PANEL CONFIGURATION FOR DOWNFLOW OR HORIZONTAL RIGHT

Figure 9

#### 7.4 Tubing Connections for Flowrator Model

1. Loosen the 13/16 nut 1 TURN ONLY to allow high pressure tracer gas to escape. No gas indicates a possible leak.
2. After the gas has been expelled, remove the nut and discard the black or brass cap plastic seal.
3. Remove the flowrator piston to verify it is the correct size for the outdoor unit being installed and then replace the piston (changing size, if needed). See piston kit chart in the literature kit for appropriate piston size.
4. Remove the spin closure on the suction line using a tube cutter and deburr the tube.

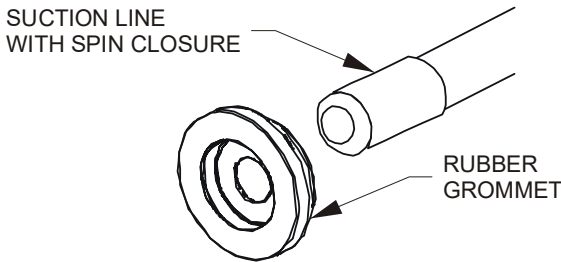

SUCTION SPUN END AND GROMMET

Figure 10

5. Insert the suction line into the connection, slide the insulation and the rubber grommet at least 18" away from the braze joint.
6. Remove the tailpiece clamped to the exterior of the cabinet or in the literature kit packet and **slide the 13/16 nut into place.**
7. Braze tailpiece to the line set liquid tube and braze suction line connection. Quench all brazed joints with a damp rag upon completion of brazing. Do not allow water to enter the inside of the tubing.
8. **AFTER THE TAILPIECE HAS COOLED,** confirm position of the white Teflon® seal and hand tighten the 13/16 nut.

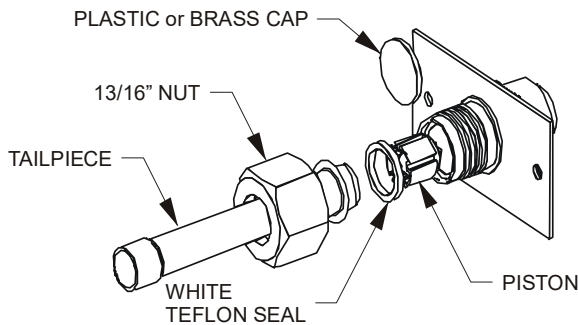

TAILPIECE JOINT

Figure 11

9. Torque the 13/16 nut to 7-25 ft-lbs. or tighten 1/6 turn.

#### 7.5 Tubing Connections for TXV Models

TXV models come with factory installed TXV with the bulb pre-installed on the vapor tube.

1. Remove refrigerant tubing panel or coil (lower) access panel.
2. Remove access valve fitting cap and depress the valve stem in access fitting to release pressure. No pressure indicates possible leak.
3. Replace the refrigerant tubing panel.
4. Remove the spin closure on both the liquid and suction tubes using a tubing cutter.
5. Insert liquid line set into liquid tube expansion and slide grommet about 18" away from braze joint.
6. Insert suction line set into suction tube expansion and slide insulation and grommet about 18" away from braze joint.
7. Braze joints. Quench all brazed joints with water or a wet rag upon completion of brazing.

#### 7.6 ASPT\*\*14\*\* Models with Non-Adjustable TXV

ASPT air handlers equipped with Parker non-adjustable TXV should be charged by subcooling only.

Models	
ASPT25B14**A	SPT47D14**
ASPT29B14**A	SPT47C14**
ASPT37B14**A	SPT49D14**
ASPT37C14**A	SPT59C14**

Table 4

See section 7.7 for detailed information on adjusting the thermal expansion valve.

#### 7.7 Thermal Expansion Valve System Adjustment

Run the system at Cooling for 10 minutes until refrigerant pressures stabilize. Use the following guidelines and methods to check unit operation and ensure that the refrigerant charge is within limits. Charge the unit on low stage.

1. Purge gauge lines. Connect service gauge manifold to base-valve service ports.
2. Temporarily install a thermometer on the liquid line at the liquid line service valve and 4-6" from the compressor on the suction line. Ensure the thermometer makes adequate contact and is insulated for best possible readings. Use liquid line temperature to determine subcooling and vapor temperature to determine superheat.
3. Check subcooling and superheat. Systems with TXV application should have a subcooling of 7 to 9°F and superheat of 7 to 9°F.
  - a. If subcooling and superheat are low, adjust TXV to 7 to 9 °F superheat, then check subcooling.

**NOTE:** To adjust superheat, turn the valve stem clockwise to increase and counter clockwise to decrease.
  - b. If subcooling is low and superheat is high, add charge to raise subcooling to 7 to 9°F then check superheat.
  - c. If subcooling and superheat are high, adjust TXV valve to 7 to 9 °F superheat, then check subcooling.



### CAUTION

EXCESSIVE TORQUE CAN CAUSE ORIFICES TO STICK. USE THE PROPER TORQUE SETTINGS WHEN TIGHTENING ORIFICES.



SATURATED SUCTION PRESSURE TEMPERATURE CHART		
SUCTION PRESSURE	SATURATED SUCTION	
PSIG	R-22	R-410A
50	26	1
52	28	3
54	29	4
56	31	6
58	32	7
60	34	8
62	35	10
64	37	11
66	38	13
68	40	14
70	41	15
72	42	16
74	44	17
76	45	19
78	46	20
80	48	21
85	50	24
90	53	26
95	56	29
100	59	31
110	64	36
120	69	41
130	73	45
140	78	49
150	83	53
160	86	56
170	90	60

SATURATED LIQUID PRESSURE TEMPERATURE CHART		
LIQUID PRESSURE	SATURATED LIQUID TEMPERATURE °F	
PSIG	R-22	R-410A
200	101	70
210	105	73
220	108	76
225	110	78
235	113	80
245	116	83
255	119	85
265	121	88
275	124	90
285	127	92
295	130	95
305	133	97
325	137	101
355	144	108
375	148	112
405	155	118
415	157	119
425	n/a	121
435	n/a	123
445	n/a	125
475	n/a	130
500	n/a	134
525	n/a	138
550	n/a	142
575	n/a	145
600	n/a	149
625	n/a	152

d. If subcooling is high and superheat is low, adjust TXV valve to 7 to 9 °F superheat and remove charge to lower the subcooling to 7 to 9°F.

**NOTE:** Units matched with indoor coils equipped with non-adjustable TXV should be charged by subcooling only.

**NOTE:** Do NOT adjust the charge based on suction pressure unless there is a gross undercharge.

4. Disconnect manifold set, installation is complete.

**NOTE:** Check the Schrader ports for leaks and tighten valve cores if necessary. Install caps finger-tight.

**SUBCOOL FORMULA =**  
**SAT. LIQUID LINE TEMP. - LIQUID LINE TEMP.**  
**SUPERHEAT FORMULA =**  
**SUCT. LINE TEMP. - SAT. SUCT. TEMP.**

**NOTE:** Expansion valve system in ASPT models are already tuned for 16 SEER single stage Heat Pump, adjustment of Expansion valve system is required in case subcool, superheat does not match to Section 7.6.3 above or when these models are installed with any other outdoor models.

## 8 Condensate Drain Lines

The coil drain pan has a primary and a secondary drain with 3/4" NPT female connections. The connectors required are 3/4" NPT male, either PVC or metal pipe, and should be hand tightened to a torque of no more than 37 in-lbs. to prevent damage to the drain pan connection. An insertion depth of approximately 3/8" to 1/2" (3-5 turns) should be expected at this torque.

1. Ensure drain pan hole is not obstructed.
2. To prevent potential sweating and dripping on to finished space, it may be necessary to insulate the condensate drain line located inside the building. Use Armaflex® or similar material.

A secondary condensate drain connection has been provided for areas where the building codes require it. Pitch all drain lines a minimum of 1/4" per foot to provide free drainage. Provide required support to the drain line to prevent bowing.

If the secondary drain line is required, run the line separately from the primary drain and end it where condensate discharge can be easily seen.

**NOTE:** Water coming from secondary line means the coil primary drain is plugged and needs immediate attention.

 <b>CAUTION</b>
<b>IF SECONDARY DRAIN IS NOT INSTALLED, THE SECONDARY ACCESS MUST BE PLUGGED.</b>

Insulate drain lines located inside the building or above a finished living space to prevent sweating. Install a condensate trap to ensure proper drainage.

**NOTE:** When units are installed above ceilings, or in other locations where damage from condensate overflow may occur, it is MANDATORY to install a field fabricated auxiliary drain pan under the coil cabinet enclosure.

The installation must include a "P" style trap that is located as close as is practical to the evaporator coil. See Figure 12 for details of a typical condensate line "P" trap.

**NOTE:** Units operating in high static pressure applications may require a deeper field constructed "P" style trap than is shown in Figure 12 to allow proper drainage and prevent condensate overflow.

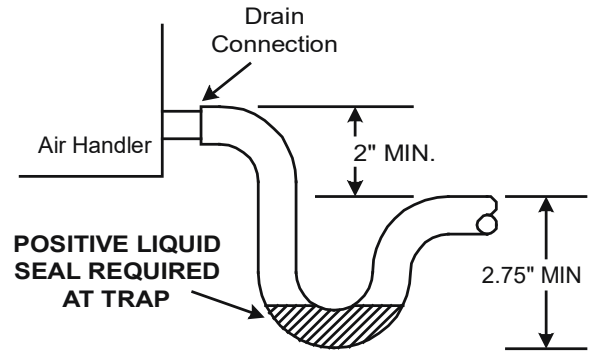

Figure 12

**NOTE:** Trapped lines are required by many local codes. In the absence of any prevailing local codes, please refer to the requirements listed in the Uniform Mechanical Building Code.

A drain trap in a draw-through application prevents air from being drawn back through the drain line during fan operation thus preventing condensate from draining, and if connected to a sewer line to prevent sewer gases from being drawn into the airstream during blower operation.

Use of a condensate removal pump is permitted when necessary. This condensate pump should have provisions for shutting off the control voltage should a blocked drain occur. A trap must be installed between the unit and the condensate pump.

**IMPORTANT NOTE:** The evaporator coil is fabricated with oils that may dissolve styrofoam and certain types of plastics. Therefore, a removal pump or float switch must not contain any of these materials.

Tip: Priming the "P" trap may avoid improper draining at the initial installation and at the beginning of the cooling season.

## 9 Ductwork

This air handler is designed for a complete supply and return ductwork system.

 <b>CAUTION</b>
<b>DO NOT OPERATE THIS PRODUCT WITHOUT ALL THE DUCTWORK ATTACHED.</b>

To ensure correct system performance, the ductwork is to be sized to accommodate 350-450 CFM per ton of cooling with the static pressure not to exceed 0.5" in w.c. Refer to ACCA Manual D, Manual S and Manual RS for information on duct sizing and application. Flame retardant ductwork is to be used and sealed to the unit in a manner that will prevent leakage.

**NOTE:** A downflow application with electric heat must have an L-shaped sheet metal supply duct without any outlets or registers located directly below the heater.

**9.1 Return Ductwork**

DO NOT LOCATE THE RETURN DUCTWORK IN AN AREA THAT CAN INTRODUCE TOXIC, OR OBJECTIONABLE FUMES/ODORS INTO THE DUCTWORK. The return ductwork is to be connected to the air handler bottom (upflow configuration).

**10 Return Air Filters**

Each installation must include a return air filter. This filtering may be performed at the air handler using the factory filter rails or externally such as a return air filter grille. When using the factory filter rails, a nominal 16x20x1", 20x20x1" or 24x20x1" (actual dimension must be less than 23-1/2"x20") filter can be installed on a B, C and D cabinet respectively (the cabinet size is the seventh letter of the model number).

**11 Electric Heat**

Refer to the installation manual provided with the electric heat kit for the correct installation procedure. All electric heat must be field installed. If installing this option, the ONLY heat kits that are permitted to be used are the HKS series. Refer to the air handler unit's Serial and Rating plate or the HKS specification sheets to determine the heat kits compatible with a given air handler. No other accessory heat kit besides the HKS series may be installed in these air handlers.

The heating mode temperature rise is dependent upon the system airflow, the supply voltage, and the heat kit size (kW) selected. Use data provided in Tables 5, 6, AND 7 to determine the temperature rise (°F).

**NOTE:** For installations not indicated above the following formula is to be used:

$$TR = (kW \times 3412) \times (\text{Voltage Correction}) / (1.08 \times \text{CFM})$$

- Where: TR = Temperature Rise
- kW = Heater Kit Actual kW
- 3412 = Btu per kW
- VC\* = .96 (230 Supply Volts)
- = .92 (220 Supply Volts)
- = .87 (208 Supply Volts)
- 1.08 = Constant
- CFM = Measured Airflow

\*VC (Voltage Correction)

**NOTE:** The Temperature Rise Tables can also be used to estimate the air handler airflow delivery. When using these tables for this purpose set the room thermostat to maximum heat and allow the system to reach steady state conditions. Insert two thermometers, one in the return air and one in the supply air. The temperature rise is the supply air temperature minus the room air temperature. Using the temperature rise calculated, CFM can be estimated from the TR formula above. See Service Manual for more information.

CFM	HEAT KIT NOMINAL kW							
	3	5	6	8	10	15	19/20	25
800	12	19	23	31	37			
1000	9	15	19	25	30	44		
1200	8	12	15	21	25	37	49	62
1400	7	11	13	18	21	32	42	53
1600	6	9	12	15	19	28	37	46
1800	5	8	10	14	16	25	33	41
2000	5	7	9	12	15	22	30	37

230/1/60 SUPPLY VOLTAGE - TEMP. RISE °F

Table 5

CFM	HEAT KIT NOMINAL kW							
	3	5	6	8	10	15	19/20	25
800	11	18	22	30	35			
1000	9	14	18	24	28	42		
1200	7	12	15	20	24	35	47	59
1400	6	10	13	17	20	30	40	51
1600	6	9	11	15	18	27	35	44
1800	5	8	10	13	16	24	31	39
2000	4	7	9	12	14	21	28	35

220/1/60 SUPPLY VOLTAGE - TEMP. RISE °F

Table 6



CFM	HEAT KIT NOMINAL kW							
	3	5	6	8	10	15	19/20	25
800	10	17	21	28	33			
1000	8	13	17	22	27	40		
1200	7	11	14	19	22	33	45	56
1400	6	10	12	16	19	29	38	48
1600	5	8	10	14	17	25	33	42
1800	5	7	9	12	15	22	30	37
2000	4	7	8	11	13	20	27	33

208/1/60 SUPPLY VOLTAGE - TEMP. RISE °F

Table 7

## 12 Electrical and Control Wiring

**IMPORTANT:** All routing of electrical wiring must be made through provided electrical knockouts. Do not cut, puncture or alter the cabinet for electrical wiring.

 <b>WARNING</b>	
<b>HIGH VOLTAGE</b> DISCONNECT ALL POWER BEFORE SERVICING OR INSTALLING THIS UNIT. MULTIPLE POWER SOURCES MAY BE PRESENT. FAILURE TO DO SO MAY CAUSE PROPERTY DAMAGE, PERSONAL INJURY OR DEATH.	
 <b>WARNING</b>	
<b>HIGH VOLTAGE!</b> TO AVOID PROPERTY DAMAGE, PERSONAL INJURY OR DEATH DUE TO ELECTRICAL SHOCK, THIS UNIT <u>MUST HAVE AN UNINTERRUPTED, UNBROKEN ELECTRICAL GROUND.</u> THE ELECTRICAL GROUND CIRCUIT MAY CONSIST OF AN APPROPRIATELY SIZED ELECTRICAL WIRE CONNECTING THE GROUND LUG IN THE UNIT CONTROL BOX TO THE BUILDING ELECTRICAL SERVICE PANEL. OTHER METHODS OF GROUNDING ARE PERMITTED IF PERFORMED IN ACCORDANCE WITH THE NATIONAL ELECTRIC CODE (NEC)/AMERICAN NATIONAL STANDARDS INSTITUTE (ANSI)/NATIONAL FIRE PROTECTION ASSOCIATION (NFPA) 70 AND LOCAL/STATE CODES. IN CANADA, ELECTRICAL GROUNDING IS TO BE IN ACCORDANCE WITH THE CANADIAN ELECTRIC CODE (CSA) C22.1.	

### 12.1 Building Electrical Service Inspection

This unit is designed for single-phase electrical supply only. DO NOT OPERATE ON A THREE-PHASE POWER SUPPLY. Measure the power supply to the unit. The supply voltage must be measured and be in agreement with the unit nameplate power requirements and within the range shown.

### 12.2 Wire Sizing

Wire size is important to the operation of your equipment. Use the following check list when selecting the appropriate wire size for your unit.

- Wire used must carry the Minimum Circuit Ampacity (MCA) listed on the unit's Series and Rating Plate.
- Refer to the NEC (USA) or CSA (Canada) for wire sizing. The unit MCA for the air handler and the optional electric heat kit can be found on the unit Series and Rating Plate.
- Wire must be sized to allow no more than a 2% voltage drop from the building breaker/fuse panel to the unit.
- Wires with different insulation temperature rating have varying ampacities - be sure to check the temperature rating used.

Refer to the latest edition of the National Electric Code or in Canada the Canadian Electric Code when determining the correct wire size.

### 12.3 Maximum Overcurrent Protection (MOP)

Every installation must include an NEC (USA) or CEC (Canada) approved overcurrent protection device. Also, check with local or state codes for any special regional requirements.

Protection can be in the form of fusing or HACR style circuit breakers. The Series and Rating Plate provides the maximum overcurrent device permissible.

**NOTE:** Fuses or circuit breakers are to be sized larger than the equipment MCA but not to exceed the MOP.

MODEL	HEATER KIT (KW)								
	3	5	6	8	10	15	19	20	25
ARUF25B14	715	715	715	715	950				
ARUF29B14	715	715	715	715	950				
ARUF31B14	715	715	715	715	875				
ARUF37C14		1170	1170	1170	1170	1345	1345		
ARUF43C14		1170	1170	1170	1170	1345	1345		
ARUF49C14		1170	1170	1170	1170	1340	1430		
ARUF37D14		1170	1170	1170	1170	1345		1345	
ARUF43D14		1170	1170	1170	1170	1345		1345	
ARUF47D14		1170	1170	1170	1170	1345		1345	
ARUF49D14		1240	1240	1240	1240	1520		1520	
ARUF61D14		1590	1590	1590	1590	1715		1715	1715

MINIMUM CFM REQUIRED FOR HEATER KITS

Table 8

Model	HEATER KIT (KW)								
	3	5	6	8	10	15	19	20	25
ASPT25B14	715	715	715	715	850				
ASPT29B14	715	715	715	715	875	1050			
ASPT35B14	715	715	715	715	875	1050			
ASPT37B14	715	715	715	715	875	1050			
ASPT33C14	715	715	715	715	875	875			
ASPT37C14		1170	1170	1170	1170	1345	1345		
ASPT39C14		1170	1170	1170	1170	1345	1345		
ASPT47C14		1170	1170	1170	1170	1345	1345		
ASPT49C14		1170	1170	1170	1170	1345	1345		
ASPT59C14		1170	1170	1170	1170	1345	1345		
ASPT47D14		1240	1240	1240	1240	1520		1520	
ASPT49D14		1590	1590	1590	1590	1715		1715	1715
ASPT61D14		1590	1590	1590	1590	1715		1715	1715

MINIMUM HEATER KIT AIRFLOW

Table 9

Nominal Input	Minimum Voltage	Maximum Voltage
208-240	197	253

ELECTRICAL VOLTAGE

Table 10

## 12.4 Electrical Connections – Supply Voltage



**IMPORTANT NOTE: USE COPPER CONDUCTORS ONLY FROM DISCONNECT OR ELECTRICAL PANEL TO THE AIR HANDLER.**

Knockouts are provided on the air handler top panel and sides of the cabinet to allow for the entry of the supply voltage conductors, as shown in Figure 13. If the knockouts on the cabinet sides are used for electrical conduit, an adapter ring must be used in order to meet UL1995 safety requirements. An NEC or CEC approved strain relief is to be used at this entry point. Some codes/municipalities require the supply wire to be enclosed in conduit. Consult your local codes.

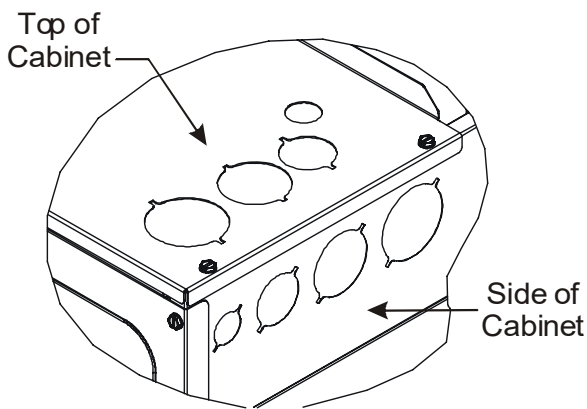

KNOCK-OUT FOR ELECTRICAL CONNECTIONS  
Figure 13

### **12.4.1 Air Handler Only (Non-Heat Kit Models)**

The building supply connects to the stripped black and red wires contained in the air handler electrical compartment cavity. A ground screw is also contained in this area. Attach the Supply wires to the air handler conductors as shown in the unit wiring diagram using appropriately sized solderless connectors or other NEC or CEC approved means.

### **12.4.2 Air Handler - Non-Circuit Breaker Heat Kits**

A terminal block is provided with the HKS kit to attach the power supply and air handler connections. Follow the HKS Installation Manual and wiring diagram for complete wiring details.

### **12.4.3 Air Handler With Circuit Breaker Heat Kit**

The air handler has soft plastic cover on the upper access panel and can be removed to allow the heater kit circuit breaker to be installed. The circuit breakers have lugs for power supply connection. See the HKS Installation Instructions for further details.

## 12.5 Low Voltage Connections

Several combinations of low voltage schemes are possible, depending on the presence of a heat kit and whether the heat kit is single-stage or multi-stage, whether the outdoor section is an air conditioner or heat pump, and whether the outdoor section is single-stage or two-stage. The 24V-control voltage connects the air handler to the room thermostat and condenser. Low voltage wiring must be copper conductors. A minimum of 18AWG must be used for installations up to 100 feet. Low voltage wiring must be connected through the top of the cabinet or either side. See the “Thermostat Wiring” section of this manual for typical low voltage wiring connections.

### **12.5.1 Thermostats**

Second-stage heat can be accomplished by a multi-stage heating thermostat or the addition of an outdoor thermostat as shown in wiring schematics on page 19. Follow the thermostat manufacturer’s instructions for installation.

## 12.6 Speed Tap Adjustment

ARUF\*\*14\*\* air handlers have multi-speed PSC motors. The color of the wire coming from the motor to the “COM” terminal on the control board defines at which speed the motor will operate. Black wire is high speed, blue wire is medium speed and red wire is low speed. To change speeds, remove the wire attached to the “COM” terminal on the control board, and swap it with the wire (on terminal “M1” or “M2”) with the color that will give the desired speed.



ASPT\*\*14\*\* air handlers feature energy efficient blower motors. The motors run at a constant torque with very low power consumption and are energized by 24 VAC. Adjust the CFM by changing the 24 VAC leads to the desired speed tap on the terminal block. The ASPT blower motor speeds are programmed to deliver adequate airflow at rated external static pressure and with 60 second off time delay. For details, refer to the specification sheet applicable to your model.

**NOTE:** In some models, not all speed taps are allowable for certain electric heat applications. Refer to Table 6 for minimum speed.

### 13 Achieving 1.4% Low Leakage Rate

Ensure all the gaskets remain intact on all surfaces as shipped with the unit. These surfaces are areas between the upper tie plate and blower access panel, blower access and coil access panels, and between the coil access and filter access panels. Ensure upon installation, that the plastic breaker cover is sitting flush on the blower access panel and all access panels are flush with each other and the cabinet. With these requirements satisfied, the unit achieves less than 1.4% airflow leakage when tested in accordance with ASHRAE Standard 193.

### 14 Start-Up Procedure

 <b>WARNING</b>	
<b>HIGH VOLTAGE</b> DISCONNECT ALL POWER BEFORE SERVICING OR INSTALLING THIS UNIT. MULTIPLE POWER SOURCES MAY BE PRESENT. FAILURE TO DO SO MAY CAUSE PROPERTY DAMAGE, PERSONAL INJURY OR DEATH.	

- Prior to start-up, ensure that all electrical wires are properly sized and all connections are properly tightened.
- All panels must be in place and secured. For Air Tight application, gasket must be positioned at prescribed locations to achieve 1.4% leakage.
- Tubing must be leak free.
- Condensate line must be trapped and pitched to allow for drainage.
- Low voltage wiring is properly connected.
- Auxiliary drain is installed when necessary and pitched to allow for drainage.
- Unit is protected from vehicular or other physical damage.
- Return air is not obtained from, nor are there any return air duct joints that are unsealed in, areas where there may be objectionable odors, flammable vapors or products of combustion such as carbon monoxide (CO), which may cause serious personal injury or death.

### 15 Regular Maintenance

The only item required to be maintained on a regular basis by the user is the circulating air filter(s). Filter should be cleaned or replaced regularly, typically once per month. A certified service technician must perform all other services.

**IMPORTANT NOTE:** If thumb screws are used to access the filter, ensure the washer installed on the screw behind the access panel remains in place after re-installation.

## 16 Airflow Data

Model	Blower Speed	Static Pressure (in w.c) Airflow (CFM)						
		0.1	0.2	0.3	0.4	0.5	0.6	0.7
ARUF25B14	LOW	650	620	595	540	490	420	275
	MED	885	865	825	815	750	690	560
	HIGH	1255	1225	1130	1090	965	925	800
ARUF29B14	LOW	650	620	595	540	490	420	275
	MED	885	865	825	815	750	690	560
	HIGH	1255	1225	1130	1090	965	925	800
ARUF31B14	LOW	660	625	595	560	500	430	330
	MED	930	905	865	820	765	700	590
	HIGH	1235	1185	1130	1060	990	910	825
ARUF37C14	LOW	1120	1085	1040	1000	940	875	800
	MED	1425	1385	1345	1285	1220	1145	1060
	HIGH	1625	1575	1520	1460	1375	1295	1200
ARUF43C14	LOW	1120	1085	1040	1000	940	875	800
	MED	1425	1385	1345	1285	1220	1145	1060
	HIGH	1625	1575	1520	1460	1375	1295	1200
ARUF49C14	LOW	1295	1255	1225	1175	1120	1055	970
	MED	1535	1485	1420	1370	1295	1215	1130
	HIGH	1755	1680	1590	1515	1425	1340	1250
ARUF37D14	LOW	1155	1115	1070	1015	955	895	840
	MED	1505	1470	1430	1375	1300	1210	1105
	HIGH	1785	1735	1680	1625	1555	1440	1330
ARUF43D14	LOW	1410	1360	1290	1210	1120	1010	920
	MED	1610	1540	1470	1390	1300	1190	1060
	HIGH	1900	1830	1740	1645	1540	1420	1280
ARUF47D14	LOW	1420	1370	1310	1240	1125	1045	960
	MED	1625	1585	1515	1435	1350	1235	1095
	HIGH	1930	1890	1820	1735	1635	1505	1355
ARUF49D14	LOW	1410	1360	1290	1210	1120	1010	920
	MED	1610	1540	1470	1390	1300	1190	1060
	HIGH	1900	1830	1740	1645	1540	1420	1280
ARUF61D14	LOW	1530	1500	1460	1405	1350	1280	1155
	MED	1950	1885	1830	1785	1745	1670	1595
	HIGH	2235	2170	2100	2030	1965	1915	1825

### Notes

1. Airflow data indicated is at 230V without air filter in place.
2. The chart is for information only. For satisfactory operation, external static pressure must not exceed value shown on
3. Use the CFM adjustment factors of 0.98 for horizontal left and 0.96 for horizontal right & downflow orientations

AIRFLOW DATA (CFM) - Table 11



Model	Blower Speed	Static Pressure (in w.c.) Airflow (CFM)								
		0.1	0.2	0.3	0.4	0.5	0.6	0.7	0.8	0.9
ASPT25B14AA	T1	640	585	580	545	510	490	410	340	280
	T2	800	765	725	700	670	645	595	565	490
	T3	840	805	800	760	740	700	670	625	580
	T4	985	950	920	885	850	815	800	760	725
	T5	1475	1440	1400	1375	1335	1305	1270	1240	1150
ASPT29B14AA	T1	595	590	565	530	505	455	380	305	260
	T2	790	775	745	705	665	625	585	515	445
	T3	865	820	790	770	735	695	645	595	530
	T4	1015	980	955	925	880	840	795	770	720
	T5	1505	1465	1430	1410	1385	1350	1315	1285	1220
ASPT35B14AA	T1	875	845	845	825	795	780	730	680	630
	T2	985	945	925	915	905	880	845	795	760
	T3	1070	1025	990	985	980	960	940	905	860
	T4	1245	1205	1170	1135	1115	1115	1100	1090	1035
	T5	1310	1275	1230	1190	1155	1135	1085	1080	1040
ASPT37B14AA	T1	1025	985	945	910	875	830	795	735	690
	T2	1150	1105	1065	1025	995	950	915	870	825
	T3	1240	1200	1160	1120	1085	1050	1010	970	925
	T4	1425	1400	1355	1320	1290	1250	1215	1180	1145
	T5	1490	1455	1415	1390	1355	1320	1285	1250	1205
ASPT33C14AA	T1	865	885	820	785	720	660	600	550	490
	T2	935	880	820	785	720	660	600	550	490
	T3	1110	1050	1000	955	905	855	795	760	710
	T4	1360	1310	1260	1220	1180	1135	1095	1055	1010
	T5	1560	1515	1475	1435	1395	1370	1330	1295	1260
ASPT37C14AA	T1	980	935	895	860	825	800	755	710	665
	T2	1125	1075	1045	1000	965	930	880	845	820
	T3	1235	1190	1155	1120	1085	1045	1005	965	920
	T4	1485	1450	1425	1390	1355	1315	1275	1230	1190
	T5	1565	1535	1510	1480	1440	1390	1365	1320	1280
ASPT39C14AA	T1	865	885	820	785	720	660	600	550	490
	T2	935	880	820	785	720	660	600	550	490
	T3	1110	1050	1000	955	905	855	795	760	710
	T4	1360	1310	1260	1220	1180	1135	1095	1055	1010
	T5	1560	1515	1475	1435	1395	1370	1330	1295	1260
ASPT47C14AA	T1	955	895	855	840	780	735	675	615	560
	T2	1100	1050	1005	965	925	870	815	770	705
	T3	1205	1160	1120	1075	1035	990	940	885	830
	T4	1445	1410	1365	1320	1275	1235	1190	1140	1095
	T5	1525	1480	1435	1400	1360	1320	1275	1230	1180
ASPT49C14AA	T1	1325	1280	1240	1200	1160	1115	1065	1025	990
	T2	1465	1420	1380	1355	1315	1280	1245	1195	1155
	T3	1510	1470	1430	1395	1355	1330	1290	1250	1210
	T4	1600	1565	1530	1490	1460	1425	1390	1365	1295
	T5	1690	1660	1625	1590	1555	1525	1490	1400	1255
ASPT59C14AA	T1	1370	1330	1295	1255	1215	1180	1140	1100	1060
	T2	1535	1500	1465	1430	1405	1370	1335	1300	1210
	T3	1680	1645	1615	1575	1545	1510	1440	1330	1205
	T4	1905	1855	1780	1690	1605	1515	1425	1330	1205
	T5	1940	1855	1775	1700	1605	1505	1420	1320	1205
ASPT47D14AA	T1	1055	1015	950	895	830	785	730	680	620
	T2	1210	1165	1110	1070	1015	960	900	840	785
	T3	1335	1290	1250	1205	1145	1100	1050	980	910
	T4	1625	1580	1530	1495	1455	1405	1350	1295	1230
	T5	1720	1670	1625	1580	1540	1490	1435	1390	1325
ASPT49D14AA	T1	1485	1435	1380	1320	1265	1200	1230	1015	930
	T2	1570	1525	1480	1430	1370	1315	1235	1155	1035
	T3	1680	1600	1570	1555	1475	1430	1360	1280	1185
	T4	1800	1765	1715	1670	1625	1590	1510	1465	1390
	T5	2215	2160	2120	2085	2040	2000	1970	1930	1865
ASPT61D14AA	T1	1545	1495	1440	1390	1335	1260	1180	1105	1045
	T2	1705	1655	1605	1555	1505	1445	1380	1330	1275
	T3	1850	1805	1760	1710	1665	1615	1555	1500	1445
	T4	2095	2055	2020	1980	1935	1890	1845	1800	1755
	T5	2260	2205	2195	2160	2120	2075	2030	1990	1945

**Notes**

1. Airflow data indicated is at 230V without air filter in place.
2. The chart is for information only. For satisfactory operation, external static pressure must not exceed value shown on rating plate. The shaded area
3. Use the CFM adjustment factors of 0.98 for horizontal left and 0.96 for horizontal right & downflow orientations.

ASPT AIRFLOW DATA (CFM) - Table 12

## 17 Air Handler Low Voltage Connections

The following composite wiring diagrams detail various configurations in which the air handlers can be used. Examples include single-stage cooling and heat pump with single or two-stage electric heating. All these configurations can be applied with convenient connections to outdoor thermostat applications.

The following sections are detailed:

- Single-Stage Cooling
- Heat Pump

Each diagram details the connections between room thermostat and the air handlers, and the connections between the air handlers and the Condensing Unit (or Heat Pump) with optional connections to Outdoor Thermostats. For each configuration, refer to the explanation of the proper jumper(s) to remove for the corresponding blower speed that will result in the programmed fixed speed ECM motor.

**IMPORTANT: When matching the ASPT air handlers to a single speed cooling or heat pump unit, remember to connect “Y” from the thermostat to the “Y2” on the low voltage terminal board.**

Any equivalent thermostat can be used in place of the manufacturer’s thermostat part number.

# 18 Wiring Diagrams

## Low Voltage Wiring for ARUF Air Handlers

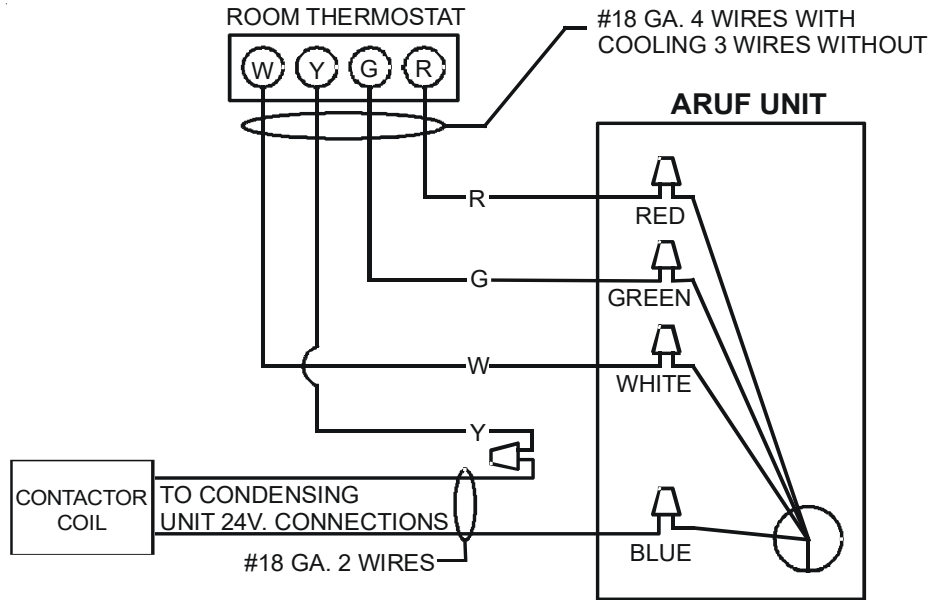

## Low Voltage Wiring Diagram for Cooling Unit with optional heat kit 10KW and below

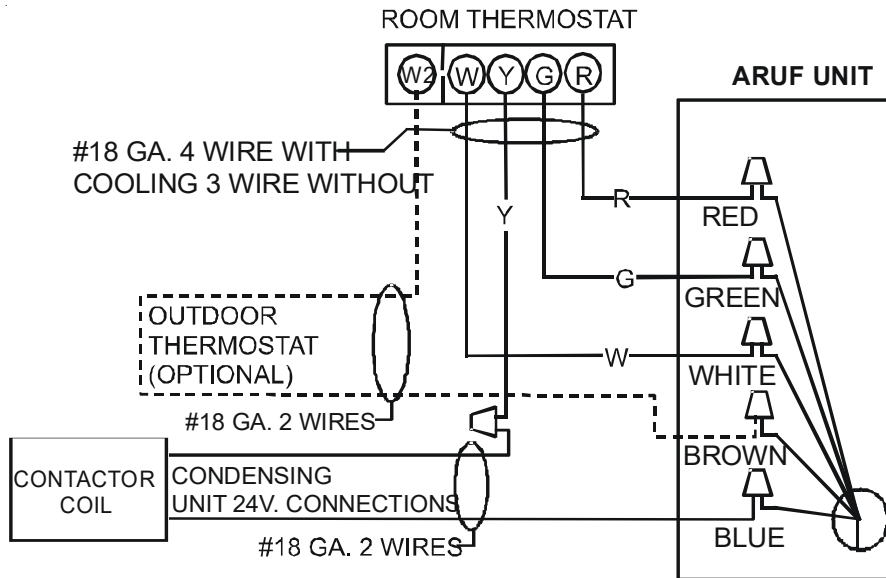

## Low Voltage Wiring Diagram for Cooling Unit with optional heat kit 15KW and above

**NOTES:**

- 1) OUTDOOR THERMOSTAT (OT-1) SHOULD BE THE FIRST TO CLOSE AND THE LAST TO OPEN.
- 2) CONNECT WHITE AND BROWN WIRES FROM AIR HANDLER TOGETHER IF OT-2 IS NOT USED.
- 3) REMOVE WIRE WHEN USING OUTDOOR THERMOSTAT.

**NOMENCLATURE:**

- OT --- OUTDOOR THERMOSTAT (OPTIONAL)  
 EHR - EMERGENCY HEAT RELAY (OPTIONAL)

**COLOR CODES**

- R -- RED  
 Y -- YELLOW  
 BL - BLUE  
 BR - BROWN  
 O -- ORANGE  
 W - WHITE  
 G -- GREEN

**HIGH VOLTAGE!**  
 DISCONNECT ALL POWER BEFORE SERVICING OR INSTALLING THIS UNIT.  
 MULTIPLE POWER SOURCES MAY BE PRESENT. FAILURE TO DO SO MAY CAUSE PROPERTY DAMAGE, PERSONAL INJURY OR DEATH.

**WARNING**

Wiring is subject to change. Always refer to the wiring diagram on the unit for the most up-to-date wiring.

# 18 Wiring Diagrams

## Low Voltage Wiring for ARUF Air Handlers

**HIGH VOLTAGE!**  
 DISCONNECT ALL POWER BEFORE SERVICING OR INSTALLING THIS UNIT.  
 MULTIPLE POWER SOURCES MAY BE PRESENT. FAILURE TO DO SO MAY  
 CAUSE PROPERTY DAMAGE, PERSONAL INJURY OR DEATH.

**WARNING**

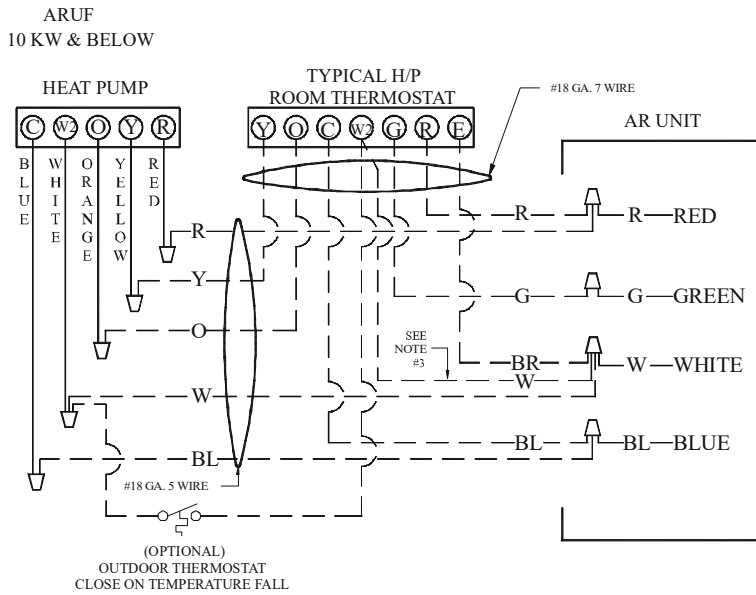

#18 GA. 6 WIRE NEEDED WHEN OT IS USED

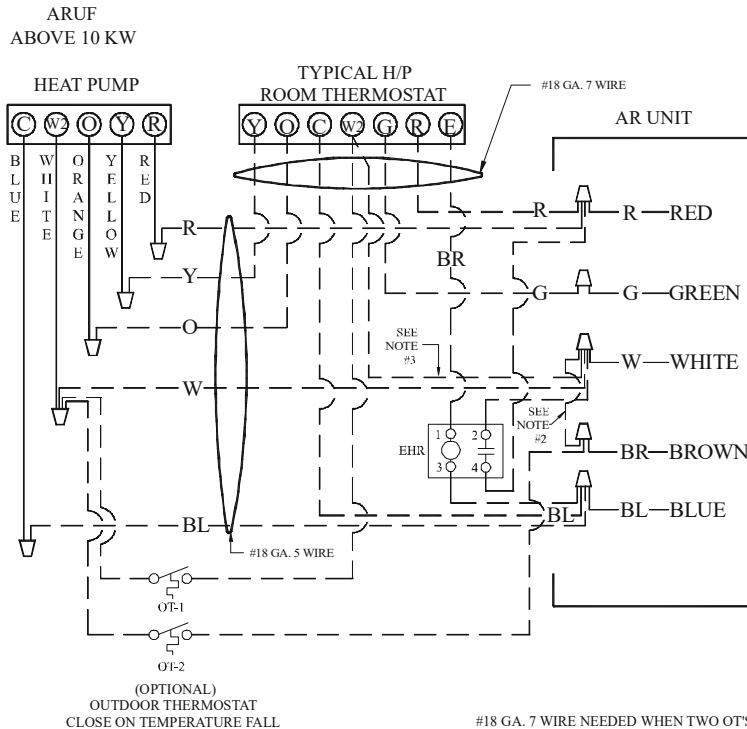

#18 GA. 7 WIRE NEEDED WHEN TWO OT'S ARE USED

**NOTES:**

- 1) OUTDOOR THERMOSTAT (OT-1) SHOULD BE THE FIRST TO CLOSE AND THE LAST TO OPEN.
- 2) CONNECT WHITE AND BROWN WIRES FROM AIR HANDLER TOGETHER IF OT-2 IS NOT USED.
- 3) REMOVE WIRE WHEN USING OUTDOOR THERMOSTAT.

**NOMENCLATURE:**

- OT --- OUTDOOR THERMOSTAT (OPTIONAL)  
 EHR - EMERGENCY HEAT RELAY (OPTIONAL)

**COLOR CODES:**

- R -- RED  
 Y -- YELLOW  
 BL - BLUE  
 BR - BROWN  
 O -- ORANGE  
 W - WHITE  
 G -- GREEN

Wiring is subject to change. Always refer to the wiring diagram on the unit for the most up-to-date wiring.

# 18 Wiring Diagrams

**HIGH VOLTAGE!**  
 DISCONNECT ALL POWER BEFORE SERVICING OR INSTALLING THIS UNIT.  
 MULTIPLE POWER SOURCES MAY BE PRESENT. FAILURE TO DO SO MAY  
 CAUSE PROPERTY DAMAGE, PERSONAL INJURY OR DEATH.

**WARNING**

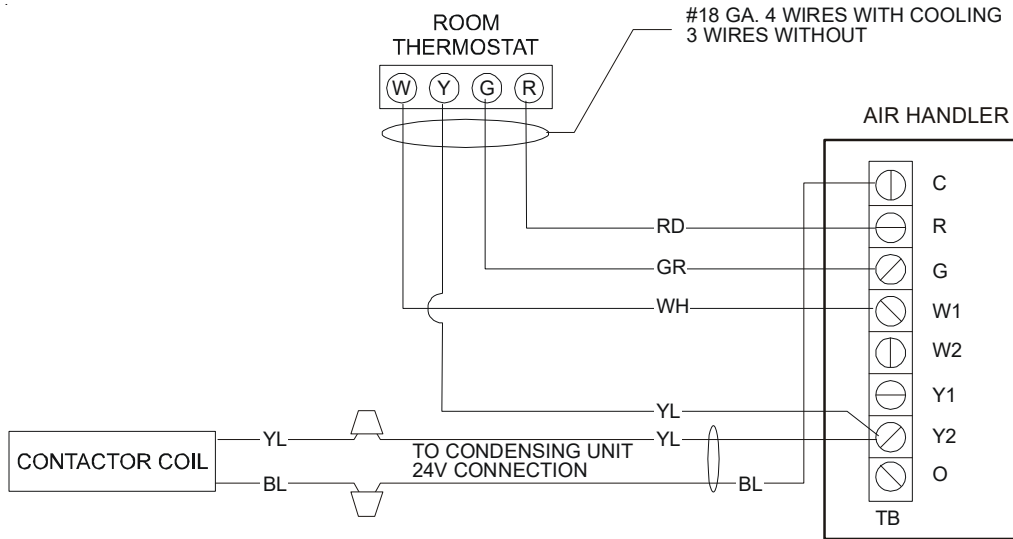

**COOLING UNIT WITH OPTIONAL HEAT KITS OF 10 kW AND BELOW**

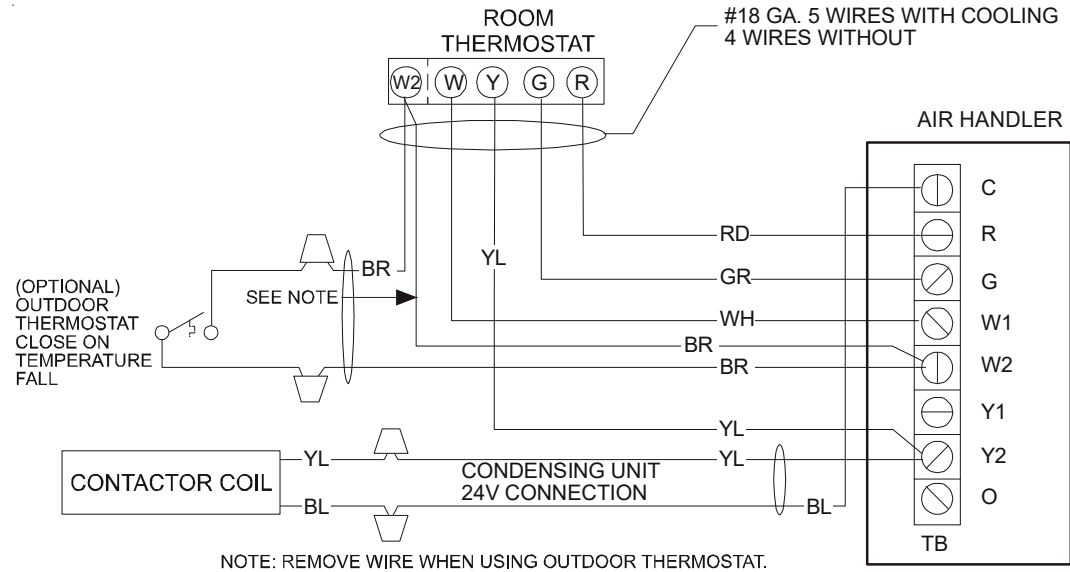

**COOLING UNIT WITH OPTIONAL HEAT KITS OF 15 kW AND ABOVE AND ROOM THERMOSTAT WITH TWO STAGES OF HEAT**

- |   |   |   |
|---|---|---|
| <p>NOTES:</p> <ol style="list-style-type: none"> <li>1) OUTDOOR THERMOSTAT (OT-1) SHOULD BE THE FIRST TO CLOSE AND THE LAST TO OPEN.</li> <li>2) JUMPER W1 AND W2 TOGETHER IF OT-2 IS NOT USED.</li> <li>3) REMOVE WIRE WHEN USING OUTDOOR THERMOSTAT.</li> </ol> | <p>NOMENCLATURE:</p> <p>OT - OUTDOOR THERMOSTAT (OPTIONAL)<br/>             EHR - EMERGENCY HEAT RELAY (OPTIONAL)</p> | <p>COLOR CODES</p> <p>RD - RED<br/>             YL - YELLOW<br/>             BL - BLUE<br/>             BR - BROWN<br/>             OR - ORANGE<br/>             WH - WHITE</p> |
|---|---|---|

Wiring is subject to change. Always refer to the wiring diagram on the unit for the most up-to-date wiring.

# 18 Wiring Diagrams

**HIGH VOLTAGE!**  
DISCONNECT ALL POWER BEFORE SERVICING OR INSTALLING THIS UNIT.  
MULTIPLE POWER SOURCES MAY BE PRESENT. FAILURE TO DO SO MAY  
CAUSE PROPERTY DAMAGE, PERSONAL INJURY OR DEATH.

**WARNING**

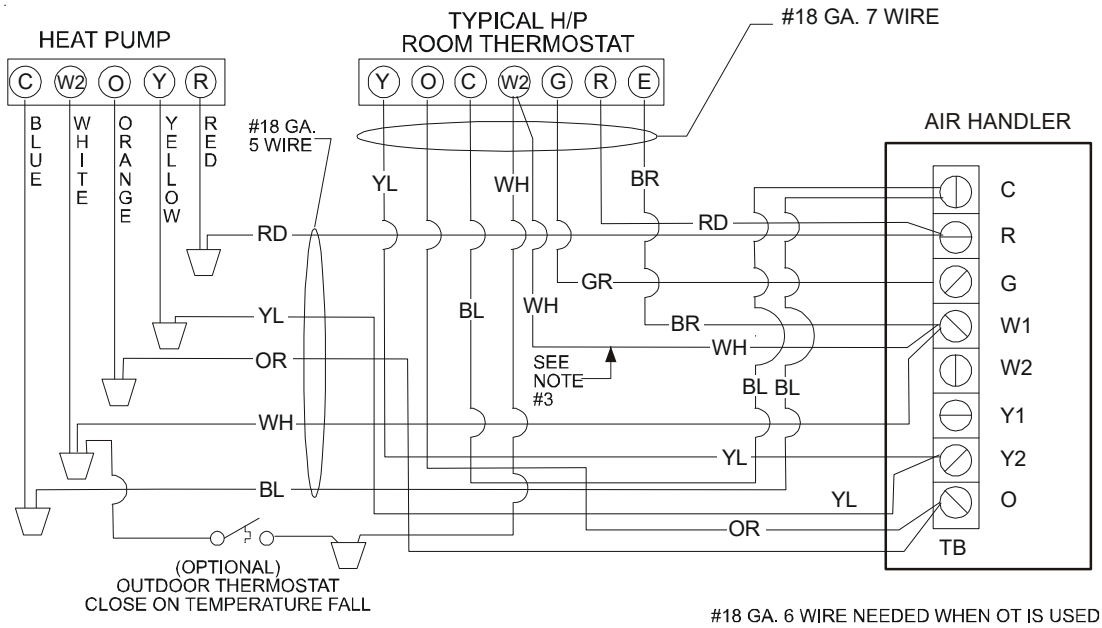

#18 GA. 6 WIRE NEEDED WHEN OT IS USED.

## HEAT PUMP UNIT WITH OPTIONAL HEAT KITS OF 10 KW AND BELOW

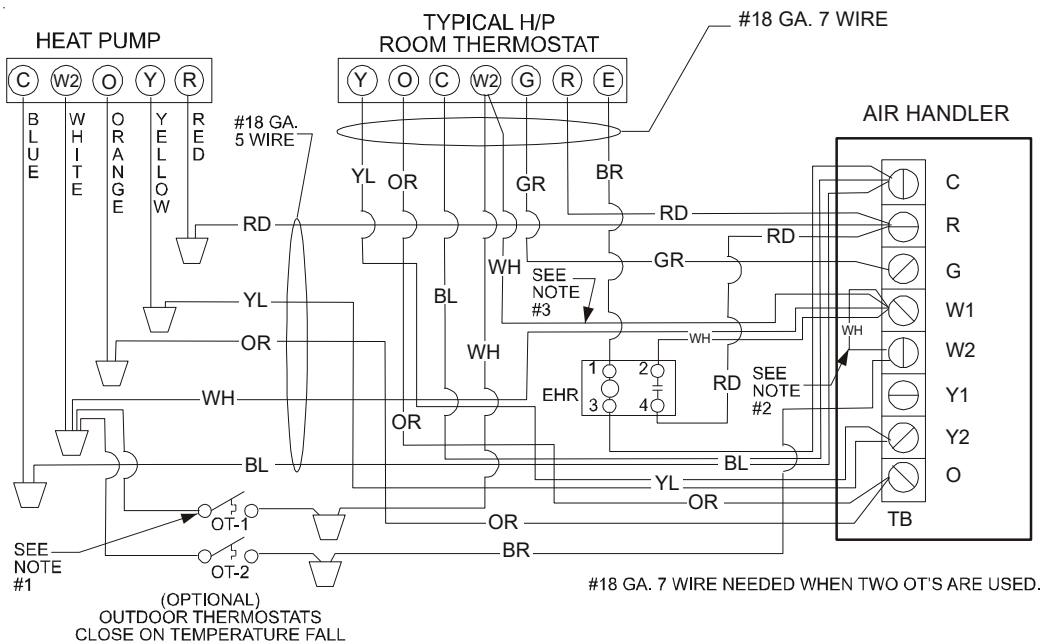

#18 GA. 7 WIRE NEEDED WHEN TWO OT'S ARE USED.

## HEAT PUMP UNIT WITH OPTIONAL HEAT KITS OF 15 KW AND ABOVE

**NOTES:**

- 1) OUTDOOR THERMOSTAT (OT-1) SHOULD BE THE FIRST TO CLOSE AND THE LAST TO OPEN.
- 2) JUMPER W1 AND W2 TOGETHER IF OT-2 IS NOT USED.
- 3) REMOVE WIRE WHEN USING OUTDOOR THERMOSTAT.

**NOMENCLATURE:**

- OT - OUTDOOR THERMOSTAT (OPTIONAL)
- EHR - EMERGENCY HEAT RELAY (OPTIONAL)

**COLOR CODES**

- RD - RED
- YL - YELLOW
- BL - BLUE
- BR - BROWN
- OR - ORANGE
- WH - WHITE

Wiring is subject to change. Always refer to the wiring diagram on the unit for the most up-to-date wiring.

# 18 Wiring Diagrams

**WARNING**

**HIGH VOLTAGE!**  
DISCONNECT ALL POWER BEFORE SERVICING OR INSTALLING THIS UNIT.  
MULTIPLE POWER SOURCES MAY BE PRESENT. FAILURE TO DO SO MAY  
CAUSE PROPERTY DAMAGE, PERSONAL INJURY OR DEATH.

## ELECTRONIC BLOWER TIME DELAY RELAY

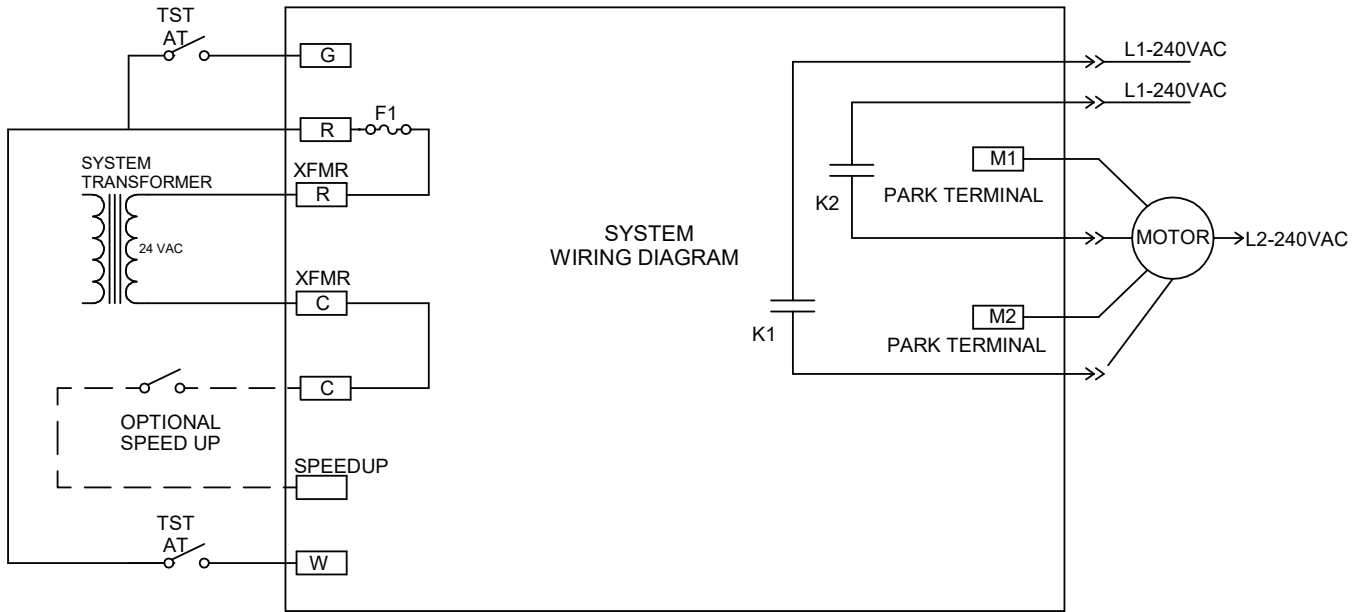

The Electronic Blower Time Delay Relay provides power to the blower motor with a delay of 7 seconds after 24VAC is applied to "G". After 24VAC is removed from "G", the blower motor output is de-energized after a delay of 65 seconds.

Normal Time Delays	60Hz	50Hz
Turn On Delay	7.0 SEC.±1%	8.4 SEC. ±1%
Turn Off Delay	65.0 SEC.±1%	78.0 SEC. ±1%

Field test mode: Shorting the "speedup" quick connect to "C" decrease times as follows:

Speedup Times	60Hz	50Hz
Turn On Delay	3.0 SEC.±1%	3.6 SEC. ±1%
Turn Off Delay	5.0 SEC.±1%	6.0 SEC. ±1%

Field test mode is cancelled when the "speedup" quick connect to "C" short is removed.

Wiring is subject to change. Always refer to the wiring diagram on the unit for the most up-to-date wiring.

# 18 Wiring Diagrams



**WARNING**

**HIGH VOLTAGE!**  
**DISCONNECT ALL POWER BEFORE SERVICING OR INSTALLING THIS UNIT.**  
**MULTIPLE POWER SOURCES MAY BE PRESENT. FAILURE TO DO SO MAY CAUSE PROPERTY DAMAGE, PERSONAL INJURY OR DEATH.**



## ARUF\*\*14\*\*

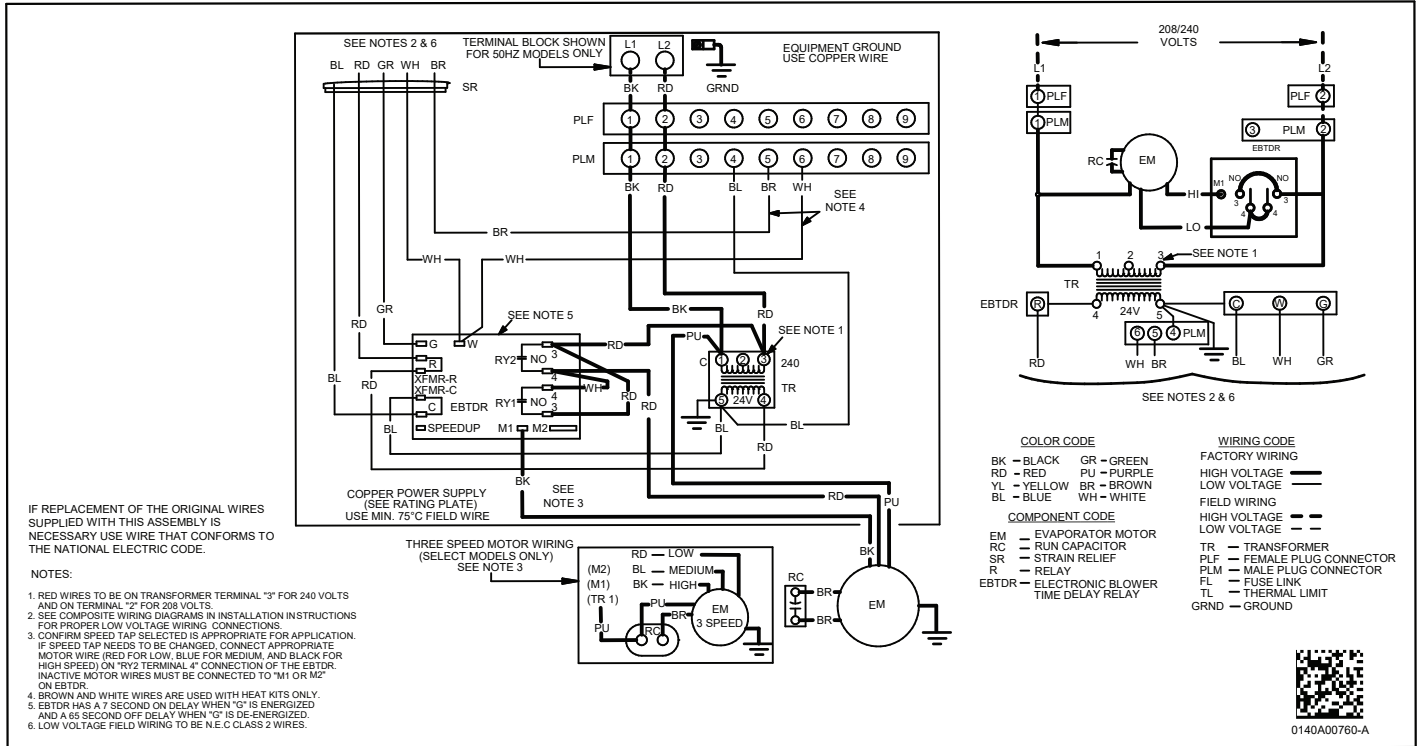

## ASPT\*\*14\*\*

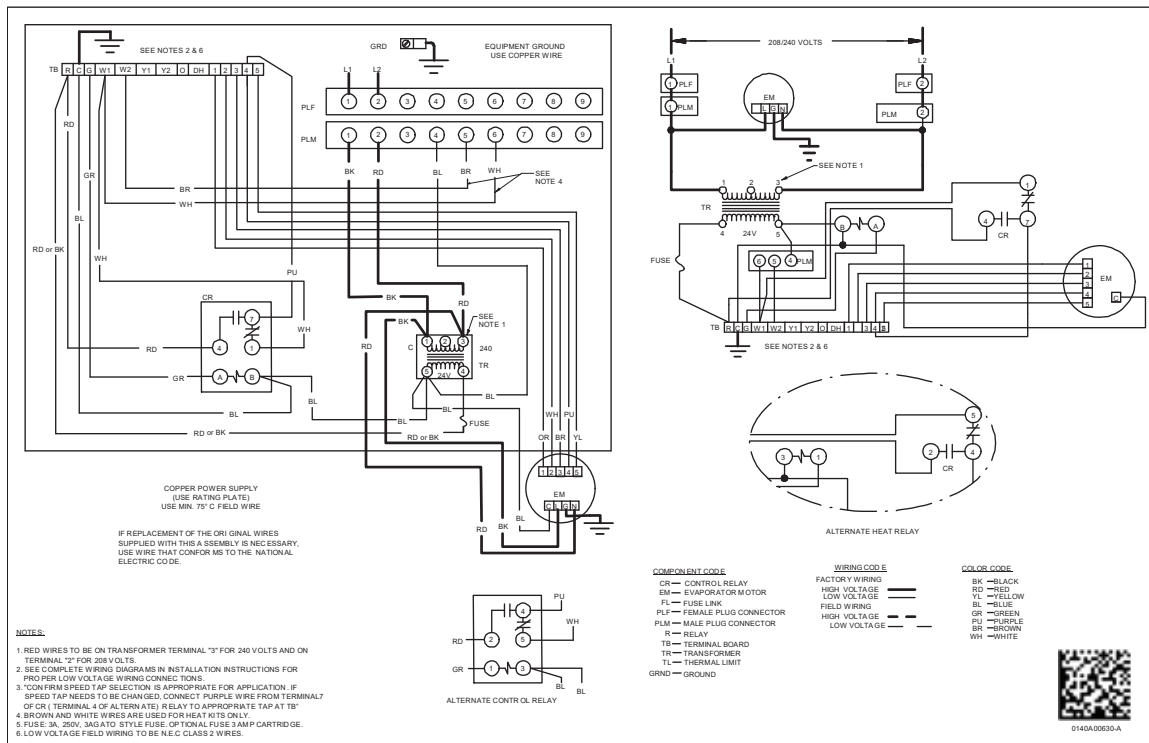

Wiring is subject to change. Always refer to the wiring diagram on the unit for the most up-to-date wiring.



# 18 Wiring Diagrams



**WARNING**

**HIGH VOLTAGE!**  
**DISCONNECT ALL POWER BEFORE SERVICING OR INSTALLING THIS UNIT.**  
**MULTIPLE POWER SOURCES MAY BE PRESENT. FAILURE TO DO SO MAY**  
**CAUSE PROPERTY DAMAGE, PERSONAL INJURY OR DEATH.**



## 3-Phase Heat Kit

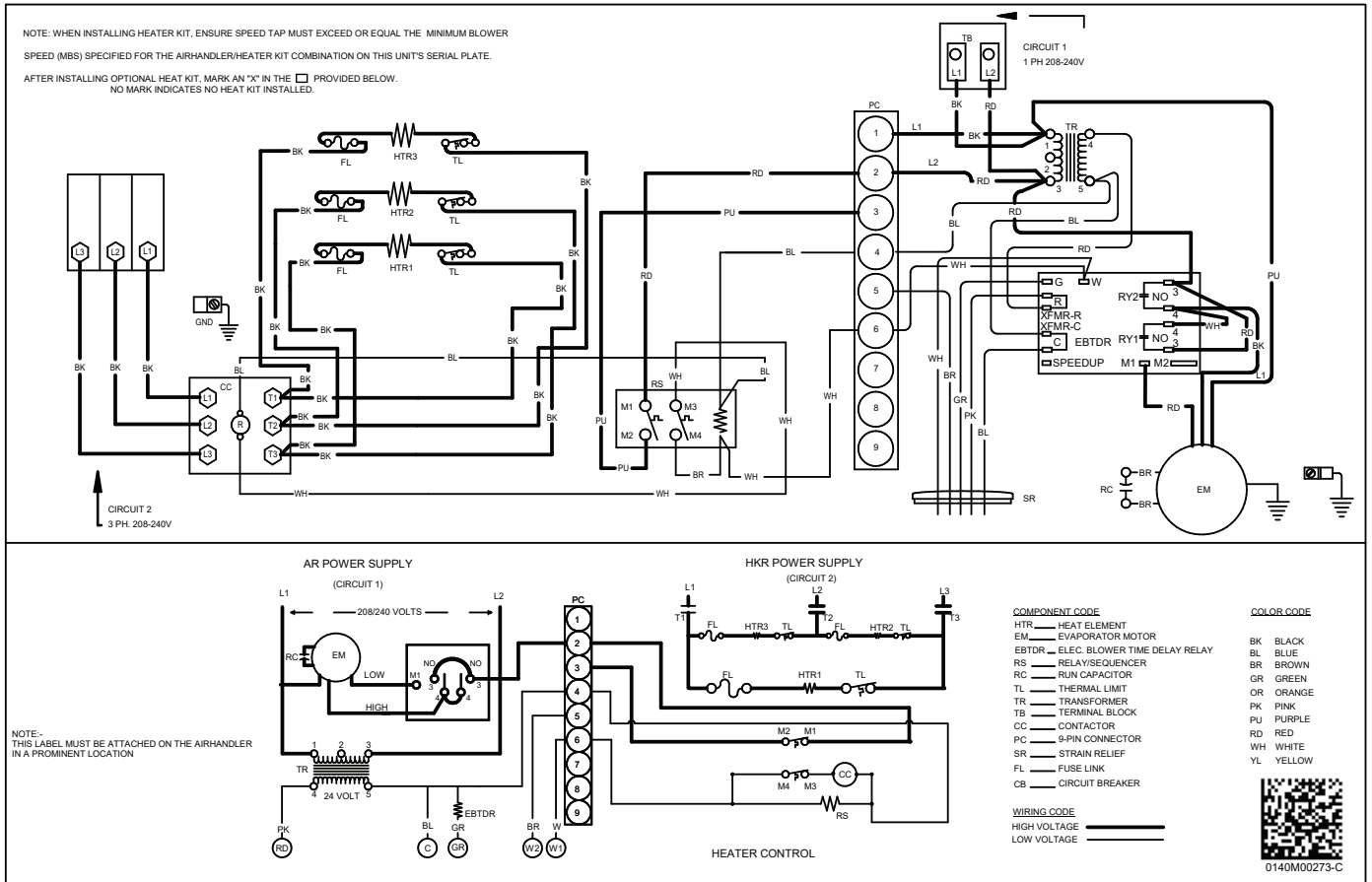

Wiring is subject to change. Always refer to the wiring diagram on the unit for the most up-to-date wiring.

## AIR HANDLER

### AIR HANDLER HOMEOWNER'S ROUTINE MAINTENANCE RECOMMENDATIONS

#### REPLACE OR CLEAN FILTER

**IMPORTANT NOTE:** Never operate unit without a filter installed as dust and lint will build up on internal parts resulting in loss of efficiency, equipment damage and possible fire.

An indoor air filter must be used with your comfort system. A properly maintained filter will keep the indoor coil of your comfort system clean. A dirty coil could cause poor operation and/or severe equipment damage.

Your air filter or filters could be located in your furnace, in a blower unit, or in "filter grilles" in your ceiling or walls. The installer of your air conditioner or heat pump can tell you where your filter(s) are, and how to clean or replace them.

Check your filter(s) at least once a month. When they are dirty, replace or clean as required. Disposable type filters should be replaced. Reusable type filters may be cleaned.

You may want to ask your dealer about high efficiency filters. High efficiency filters are available in both electronic and non-electronic types. These filters can do a better job of catching small airborne particles.

#### MOTORS

Indoor and outdoor fan motors are permanently lubricated and do not require additional oiling.



#### WARNING

##### HIGH VOLTAGE

DISCONNECT ALL POWER BEFORE SERVICING OR INSTALLING THIS UNIT. MULTIPLE POWER SOURCES MAY BE PRESENT. FAILURE TO DO SO MAY CAUSE PROPERTY DAMAGE, PERSONAL INJURY OR DEATH.



#### ALUMINUM INDOOR COIL CLEANING (QUALIFIED SERVICER ONLY)

This unit is equipped with an aluminum tube evaporator coil. The safest way to clean the evaporator coil is to simply flush the coil with water. This cleaning practice remains as the recommended cleaning method for both copper tube and aluminum tube residential evaporator coils.

It has been determined that many coil cleaners and drain pan tablets contain corrosive chemicals that can be harmful to aluminum tube and fin evaporator coils. Even a one-time application of these corrosive chemicals can cause premature aluminum evaporator coil failure. Any cleaners that contain corrosive chemicals including, but not limited to, chlorine and hydroxides, should not be used.

An alternate cleaning method is to use one of the products listed in TP-109\* to clean the coils. The cleaners listed are the only agents deemed safe and approved for use to clean round tube aluminum coils. TP-109 is also available on the web site in Partner Link > Service Toolkit.

**NOTE:** Ensure coils are rinsed well after use of any chemical cleaners.



#### CAUTION

TO AVOID THE RISK OF EQUIPMENT DAMAGE OR FIRE, INSTALL THE SAME AMPERAGE BREAKER OR FUSE AS YOU ARE REPLACING. IF THE CIRCUIT BREAKER OR DUSE SHOULD OPEN AGAIN WITHIN THIRTY DAYS, CONTACT A QUALIFIED SERVICER TO CORRECT THE PROBLEM. IF YOU REPEATEDLY RESET THE BREAKER OR REPLACE THE FUSE WITHOUT HAVING THE PROBLEM CORRECTED, YOU RUN THE RISK OF SEVERE EQUIPMENT DAMAGE.

#### BEFORE YOU CALL YOUR SERVICER

- Check the thermostat to confirm that it is properly set.
- Wait 15 minutes. Some devices in the outdoor unit or in programmable thermostats will prevent compressor operation for awhile, and then reset automatically. Also, some power companies will install devices which shut off air conditioners for several minutes on hot days. If you wait several minutes, the unit may begin operation on its own.
- Check the electrical panel for tripped circuit breakers or failed fuses. Reset the circuit breakers or replace fuses as necessary.
- Check the disconnect switch near the indoor furnace or blower to confirm that it is closed.
- Check for obstructions on the outdoor unit. Confirm that it has not been covered on the sides or the top. Remove any obstruction that can be safely removed. If the unit is covered with dirt or debris, call a qualified servicer to clean it.
- Check for blockage of the indoor air inlets and outlets. Confirm that they are open and have not been blocked by objects (rugs, curtains or furniture).
- Check the filter. If it is dirty, clean or replace it.
- Listen for any unusual noise(s), other than normal operating noise, that might be coming from the outdoor unit. If you hear unusual noise(s) coming from the unit, call a qualified servicer.

# 19 Start-Up Checklist

Air Handler / Coil					
	<b>Model Number</b>				
	<b>Serial Number</b>				
<b>ELECTRICAL</b>					
Line Voltage (Measure L1 and L2 Voltage)	L1 - L2				
Secondary Voltage (Measure Transformer Output Voltage)	R - C				
Blower Amps					
Heat Strip 1 - Amps					
Heat Strip 2 - Amps					
<b>BLOWER EXTERNAL STATIC PRESSURE</b>					
Return Air Static Pressure			IN. W.C.		
Supply Air Static Pressure			IN. W.C.		
Total External Static Pressure (Ignoring +/- from the reading above, add total here)			IN. W.C.		
<b>TEMPERATURES</b>					
Return Air Temperature (Dry bulb / Wet bulb)			DB °F		WB °F
Cooling Supply Air Temperature (Dry bulb / Wet bulb)			DB °F		WB °F
Heating Supply Air Temperature			DB °F		
Temperature Rise			DB °F		
Delta T (Difference between Supply and Return Temperatures)			DB °F		
Air Handler / Coil - (Inverter Matched)					
<b>INVERTER AH / COIL ONLY</b>					
Check EEV and EEV wiring is secure (no adjustment required)					
Additional Checks					
Check wire routings for any rubbing					
Check product for proper draining					
Check screw tightness on blower wheel					
Check factory wiring and wire connections					
Check product for proper clearances as noted by installation instructions					
°F to °C formula: $(^{\circ}\text{F} - 32) \text{ divided by } 1.8 = ^{\circ}\text{C}$ °C to °F formula: $(^{\circ}\text{C} \text{ multiplied by } 1.8) + 32 = ^{\circ}\text{F}$					

### CUSTOMER FEEDBACK

We are very interested in all product comments.

Please fill out the feedback form on one of the following links:

Daikin Products: (<https://daikincomfort.com/contact-us>)

Goodman® Brand Products: (<http://www.goodmanmfg.com/about/contact-us>).

Amana® Brand Products: (<http://www.amana-hac.com/about-us/contact-us>).

You can also scan the QR code on the right for the product brand you purchased to be directed to the feedback page.



DAIKIN



GOODMAN® BRAND



AMANA® BRAND

### PRODUCT REGISTRATION

Thank you for your recent purchase. Though not required to get the protection of the standard warranty, registering your product is a relatively short process, and entitles you to additional warranty protection, except that failure by California and Quebec residents to register their product does not diminish their warranty rights. The duration of warranty coverages in Texas differs in some cases.

For Product Registration, please register as follows:

Daikin Products: (<https://daikincomfort.com/owner-support/product-registration>).

Goodman® Brand products: (<https://www.goodmanmfg.com/product-registration>).

Amana® Brand products: (<http://www.amana-hac.com/product-registration>).

You can also scan the QR code on the right for the product brand you purchased to be directed to the Product Registration page.



DAIKIN



GOODMAN® BRAND



AMANA® BRAND

Our continuing commitment to quality products may mean a change in specifications without notice.

© 2014-2018, 2020-2023 Daikin Comfort Technologies Manufacturing, L.P.

19001 Kermier Rd., Waller, TX 77484

[www.goodmanmfg.com](http://www.goodmanmfg.com) - or - [www.amana-hac.com](http://www.amana-hac.com)

**Amana** is a registered trademark of Maytag Corporation or its related companies and is used under license. All rights reserved.