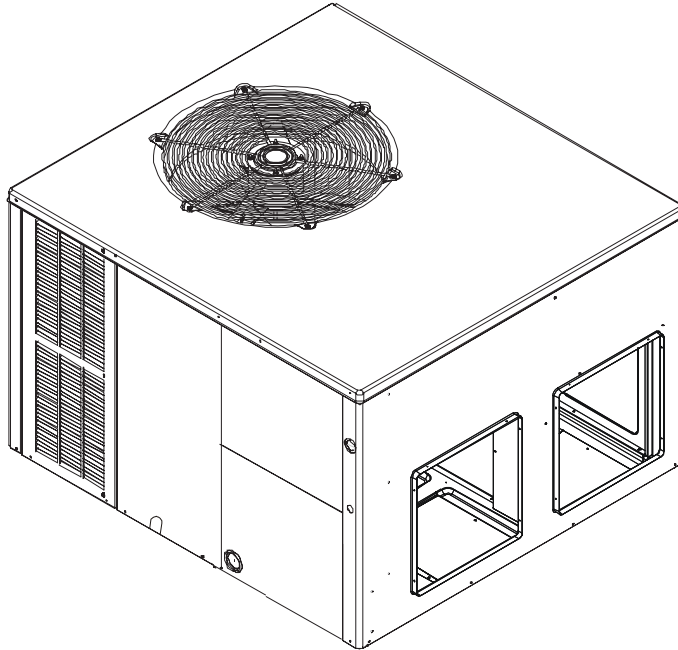

INSTALLATION INSTRUCTIONS FOR SELF-CONTAINED PACKAGE AIR CONDITIONERS AND HEAT PUMP UNITS DP3HM & DP3CM 13.4 SEER2 “M” SERIES

**WARNING**

ONLY PERSONNEL THAT HAVE BEEN TRAINED TO INSTALL, ADJUST, SERVICE, MAINTENANCE OR REPAIR (HEREINAFTER, “SERVICE”) THE EQUIPMENT SPECIFIED IN THIS MANUAL SHOULD SERVICE THE EQUIPMENT.

THIS EQUIPMENT IS NOT INTENDED FOR USE BY PERSONS (INCLUDING CHILDREN) WITH REDUCED PHYSICAL, SENSORY OR MENTAL CAPABILITIES, OR LACK OF EXPERIENCE AND KNOWLEDGE, UNLESS THEY HAVE BEEN GIVEN SUPERVISION OR INSTRUCTION CONCERNING USE OF THE APPLIANCE BY A PERSON RESPONSIBLE FOR THEIR SAFETY.

CHILDREN SHOULD BE SUPERVISED TO ENSURE THAT THEY DO NOT PLAY WITH THE EQUIPMENT.

THE MANUFACTURER WILL NOT BE RESPONSIBLE FOR ANY INJURY OR PROPERTY DAMAGE ARISING FROM IMPROPER SUPERVISION, SERVICE OR SERVICE PROCEDURES. IF YOU SERVICE THIS UNIT, YOU ASSUME RESPONSIBILITY FOR ANY INJURY OR PROPERTY DAMAGE WHICH MAY RESULT. IN ADDITION, IN JURISDICTIONS THAT REQUIRE ONE OR MORE LICENSES TO SERVICE THE EQUIPMENT SPECIFIED IN THIS MANUAL, ONLY LICENSED PERSONNEL SHOULD SERVICE THE EQUIPMENT. IMPROPER SUPERVISION, INSTALLATION, ADJUSTMENT, SERVICING, MAINTENANCE OR REPAIR OF THE EQUIPMENT SPECIFIED IN THIS MANUAL, OR ATTEMPTING TO INSTALL, ADJUST, SERVICE OR REPAIR THE EQUIPMENT SPECIFIED IN THIS MANUAL WITHOUT PROPER SUPERVISION OR TRAINING MAY RESULT IN PRODUCT DAMAGE, PROPERTY DAMAGE, PERSONAL INJURY OR DEATH.

**WARNING**

DO NOT BYPASS SAFETY DEVICES

RECOGNIZE THIS SYMBOL
AS A SAFETY PRECAUTION.

Our continuing commitment to quality products may mean a change in specifications without notice.

©2022-2023 **DAIKIN COMFORT TECHNOLOGIES MANUFACTURING, L.P.**

19001 Kermier Rd. Waller, TX 77484

www.daikincomfort.com



TABLE OF CONTENTS

TO THE INSTALLER.....	2
SHIPPING INSPECTION.....	3
CHECKING PRODUCT RECEIVED.....	3
MESSAGE TO THE HOMEOWNER.....	3
REPLACEMENT PARTS.....	3
ORDERING PARTS.....	3
IMPORTANT SAFETY INSTRUCTIONS.....	3
RECOGNIZE SAFETY SYMBOLS, WORDS AND LABELS..	3
CODES AND REGULATIONS.....	3
GENERAL.....	3
EPA REGULATIONS.....	4
NATIONAL CODES.....	4
MAJOR COMPONENTS.....	4
INSTALLATION.....	4
PRE-INSTALLATION CHECKPOINTS.....	4
CLEARANCES AND ACCESSIBILITY.....	4
GROUND LEVEL INSTALLATION DETAILS.....	4
UNIT LOCATION.....	4
ROOF TOP INSTALLATION DETAILS.....	5
ROOF CURB INSTALLATIONS	5
RIGGIN DETAILS.....	5
CIRCULATING AIR AND FILTERS.....	6
AIR FLOW CONVERSION.....	6
DUCT WORK.....	7
MANUFACTURED HOME MOD KIT.....	7
PLENUM APPLICATION.....	7
FILTERS.....	7
CONDENSATE DRAIN PIPING.....	8
ELECTRICAL WIRING.....	8
HIGH VOLTAGE WIRING.....	9
LOW VOLTAGE WIRING.....	9
INTERNAL WIRING.....	9
START-UP PROCEDURES AND CHECKLISTS.....	9
AIR CONDITIONER START UP PROCEDURE.....	9
HEAT PUMP START UP PROCEDURE.....	9
FINAL SYSTEM CHECKS.....	10
COMPONENTS.....	10
CONTACTOR.....	10
CRANKCASE HEATER.....	10
CONDENSER MOTOR.....	10
COMPRESSOR.....	10
CONTACTOR RELAY.....	10
DEFROST CONTROL.....	10
OUTDOOR THERMOSTAT.....	10
REVERSING VALVE COIL.....	11
INDOOR BLOWER MOTOR.....	11
BLOWER INTERLOCK RELAY.....	11
HEAT PUMP OPERATION.....	11
COOLING CYCLE.....	11
HEATING CYCLE.....	11
DEFROST CONTROL.....	11
SUGGESTED FIELD TESTING/TROUBLESHOOTING.....	12
TESTING DEFROST THERMOSTAT.....	12
AIRFLOW MEASUREMENT AND ADJUSTMENT.....	12
TOTAL EXTERNAL STATIC PRESSURE.....	13

ADJUSTING SPEED TAP FOR ID BLOWER MOTOR.....	13
EEM MOTOR.....	13
DP3HM CFM DELIVERY AND ADJUSTMENTS.....	13
DP3HM THERMOSTAT “FAN ONLY” MODE.....	13
DP3HM HUMIDITY CONTROL.....	13
SUPERHEAT AND SUBCOOLING.....	13
CHECKING SUBCOOLING.....	13
CHECKING SUPERHEAT.....	13
SUPERHEAT ADJUSTMENT.....	13
REFRIGERANT CHARGE CHECK.....	14
ELECTRIC HEAT INSTALLATION & ADJUSTMENT.....	14
HEATERKIT.....	14
MAINTENANCE.....	14
SERVICE.....	14
INADEQUATE AIR VOLUME THROUGH ID COIL.....	15
OUTSIDE AIR INTO RETURN DUCT.....	15
MALFUNCTIONING REVERSING VALVE 12.....	15
POOR “TERMINATING” SENSOR CONTACT.....	15
UNDERCHARGE.....	15
TROUBLESHOOTING CHART.....	17
DP3HM BLOWER PERFORMANCE DATA.....	18
UNIT DIMENSIONS.....	21
HOMEOWNER’S ROUTINE MAINTENANCE.....	22
START-UP CHECKLIST.....	23

TO THE INSTALLER

Carefully read all instructions for the installation prior to installing unit. Make sure each step or procedure is understood and any special considerations are taken into account before starting installation. Assemble all tools, hardware and supplies needed to complete the installation. Some items may need to be purchased locally. After deciding where to install unit, closely look the location over – both the inside and outside of the home. Note any potential obstacles or problems that might be encountered as noted in this manual. Choose a more suitable location if necessary.

IMPORTANT NOTE: IF A CRANKCASE HEATER IS USED, THE UNIT SHOULD BE ENERGIZED 24 HOURS PRIOR TO COMPRESSOR START UP TO ENSURE CRANKCASE HEATER HAS SUFFICIENTLY WARMED THE COMPRESSOR. COMPRESSOR DAMAGE MAY OCCUR IF THIS STEP IS NOT FOLLOWED.

Before using this manual, check the serial plate for proper model identification.

The installation and servicing of this equipment must be performed by qualified, experienced technicians only.

SHIPPING INSPECTION

CHECKING PRODUCT RECEIVED

Upon receiving the unit, inspect it for damage from shipment. Claims for damage, either shipping or concealed, should be filed immediately with the shipping company. Check the unit model number, specifications, electrical characteristics, and accessories to determine if they are correct. In the event an incorrect unit is shipped, it must be returned to the supplier and must NOT be installed. The manufacturer assumes no responsibility for installation of incorrectly shipped units.

MESSAGE TO THE HOMEOWNER

These instructions are addressed primarily to the installer; however, useful maintenance information is included and should be kept, after installation, for future reference.

REPLACEMENT PARTS

ORDERING PARTS

When reporting shortages or damages, or ordering repair parts, give the complete unit model and serial numbers as stamped on the unit's nameplate. Replacement parts for this appliance are available through your contractor or local distributor. For the location of your nearest distributor, consult the white business pages, the yellow page section of the local telephone book or contact:

**HOMEOWNER'S SUPPORT
DAIKIN COMFORT TECHNOLOGIES
MANUFACTURING, L.P.
19001 KERMIER ROAD
WALLER, TEXAS 77484
(855) 770-5678**

IMPORTANT SAFETY INSTRUCTIONS

RECOGNIZE SAFETY SYMBOLS, WORDS, AND LABELS.

The following symbols and labels are used throughout this manual to indicate immediate or potential hazards. It is the owner's responsibility to read and comply with all safety information and instructions accompanying these symbols. Failure to heed safety information increases the risk of serious personal injury or death, property damage and/or product damage.



WARNING

DO NOT CONNECT TO OR USE ANY DEVICE THAT IS NOT DESIGN CERTIFIED BY THE MANUFACTURER FOR USE WITH THIS UNIT. SERIOUS PROPERTY DAMAGE, PERSONAL INJURY, REDUCED UNIT PERFORMANCE AND/OR HAZARDOUS CONDITIONS MAY RESULT FROM THE USE OF SUCH NON-APPROVED DEVICES.



WARNING

HIGH VOLTAGE!
DISCONNECT ALL POWER BEFORE SERVICING OR INSTALLING THIS UNIT. MULTIPLE POWER SOURCES MAY BE PRESENT. FAILURE TO DO SO MAY CAUSE PROPERTY DAMAGE, PERSONAL INJURY OR DEATH.



WARNING

CONNECTING UNIT DUCTWORK TO UNAUTHORIZED HEAT PRODUCING DEVICES SUCH AS A FIREPLACE INSERT, STOVE, ETC. MAY RESULT IN PROPERTY DAMAGE, FIRE, CARBON MONOXIDE POISONING, EXPLOSION, PERSONAL INJURY OR DEATH.



WARNING

TO AVOID PROPERTY DAMAGE, PERSONAL INJURY OR DEATH, DO NOT USE THIS UNIT IF ANY PART HAS BEEN UNDER WATER. IMMEDIATELY CALL A QUALIFIED SERVICE TECHNICIAN TO INSPECT THE UNIT AND TO REPLACE ANY PART OF THE CONTROL SYSTEM AND ANY GAS CONTROL HAVING BEEN UNDER WATER.



WARNING

THIS UNIT MUST NOT BE USED AS A "CONSTRUCTION HEATER" DURING THE FINISHING PHASES OF CONSTRUCTION ON A NEW STRUCTURE. THIS TYPE OF USE MAY RESULT IN PREMATURE FAILURE OF THE UNIT DUE TO EXTREMELY LOW RETURN AIR TEMPERATURES AND EXPOSURE TO CORROSIVE OR VERY DIRTY ATMOSPHERES.



WARNING

TO PREVENT THE RISK OF PROPERTY DAMAGE, PERSONAL INJURY, OR DEATH, DO NOT STORE COMBUSTIBLE MATERIALS OR USE GASOLINE OR OTHER FLAMMABLE LIQUIDS OR VAPORS IN THE VICINITY OF THIS APPLIANCE.

CODES AND REGULATIONS

GENERAL

The DP3HM SEER2 M-Series heat pumps are designed for OUTDOOR USE ONLY. DP3HM SEER2 M-Series is available in cooling capacities of 2, 2.5, 3, 3.5, 4 and 5 nominal tons of cooling. Optional field-installed heat kits are available in 5, 8, 10, 15 and 20kW. The units can be easily installed in manufactured or modular homes with existing high-static duct work. The units can also be easily converted to accommodate a plenum for normal or low-static applications. The DP3HM SEER2 M-Series are self-contained packaged units so the only connections needed for installation are the supply and return ducts, the line and low voltage wiring and drain connection. Rated performance is achieved after 20 hours of operation. Rated performance is delivered at the specified airflow. See product specification for packaged models.

Specification sheets can be found at www.daikincomfort.com for Daikin brand products. Within the website, please select the products menu and then select the submenu for the type of product to be installed, such as air conditioners or heat pumps, to access a list of product pages that each contain links to that model's specification sheet.

The units are ETL listed, and AHRI certified. The information on the rating plate is in compliance with FTC and DOE rating for single phase units.

EPA REGULATIONS

IMPORTANT: THE UNITED STATES ENVIRONMENTAL PROTECTION AGENCY (EPA) HAS ISSUED VARIOUS REGULATIONS REGARDING THE INTRODUCTION AND DISPOSAL OF REFRIGERANTS IN THIS UNIT. FAILURE TO FOLLOW THESE REGULATIONS MAY HARM THE ENVIRONMENT AND CAN LEAD TO THE IMPOSITION OF SUBSTANTIAL FINES. BECAUSE REGULATIONS MAY VARY DUE TO PASSAGE OF NEW LAWS, WE SUGGEST A CERTIFIED TECHNICIAN PERFORM ANY WORK DONE ON THIS UNIT. SHOULD YOU HAVE ANY QUESTIONS PLEASE CONTACT THE LOCAL OFFICE OF THE EPA.

NATIONAL CODES

This product is designed and manufactured to permit installation in accordance with National Codes. It is the installer's responsibility to install the product in accordance with National Codes and/or prevailing local codes and regulations.

MAJOR COMPONENTS

The unit includes a hermetically sealed refrigerating system (consisting of a compressor, condenser coil, evaporator coil with flowrator), an indoor blower, a condenser fan, and all necessary internal electrical wiring. The heat pump also includes a reversing valve, solenoid, defrost thermostat and control and loss of charge protection. The system is factory-evacuated, charged and performance tested. Refrigerant amount and type are indicated on rating plate.

INSTALLATION

PRE-INSTALLATION CHECKPOINTS

Before attempting any installation, the following points should be considered:

- Structural strength of supporting members
- Clearances and provision for servicing
- Power supply and wiring
- Air duct connections
- Drain facilities and connections
- Location may be on any four sides of a home, manufactured or modular, to minimize noise

CLEARANCE

The unit is designed to be located outside the building with unobstructed condenser air inlet and discharge. Additionally, the unit must be situated to permit access for service and installation. Condenser air enters from three sides. Air discharges upward from the top of the unit. Refrigerant gauge connections are made on the right side of the unit as you face the compressor compartment. Electrical connections can be made either on the right or left sides of the unit. The best and most common application is for the unit to be located 12" from the wall (4"

minimum) with the connection side facing the wall. This "close to the wall" application minimizes exposed wiring. Close to the wall application assures free, unobstructed air to the other two sides. In more confined application spaces, such as corners provide a minimum 12" clearance on all air inlet sides. Allow 36" minimum for service access to the compressor compartment and controls. The top of the unit should be completely unobstructed. If units are to be located under an overhang, there should be a minimum of 48" clearance and provisions made to deflect the warm discharge air out from the overhang. See FIGURE 1: GROUND LEVEL INSTALLATION below.

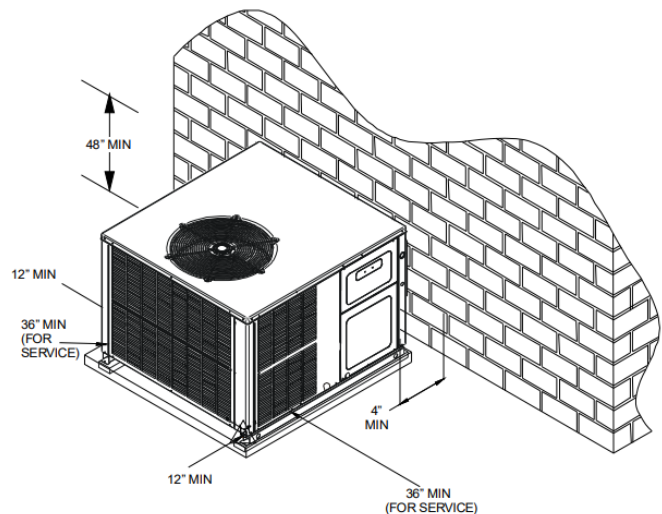

FIGURE 1: GROUND LEVEL INSTALLATION

UNIT LOCATION

Consider the effect of outdoor fan noise on conditioned space and any adjacent occupied space. It is recommended that the unit be placed so that condenser air discharge does not blow toward windows less than 25 feet away.

The unit should be set on a solid, level foundation – preferably a concrete slab at least 4 inches thick. The slab should be above ground level and surrounded by a graveled area for good drainage. Any slab used as a unit's foundation should not adjoin the building as it is possible that sound and vibration may be transmitted to the structure. For rooftop installation, steel or treated wood beams should be used as unit support for load distribution.

Heat Pumps require special location consideration in areas of heavy snow accumulation and/or areas with prolonged continuous subfreezing temperatures. Heat pump unit bases have holes under the outdoor coil to permit drainage of defrost water accumulation. The unit must be situated to permit free unobstructed drainage of the defrost water and ice. A minimum of 2" clearance under the outdoor coil is required in milder climates.

Heat Pump Elevation Chart	
Design Temperature	Suggested Minimum Elevation
+15° and above	2 1/2"
-5° to +14°	8"
Below -5°	12"

ROOF TOP INSTALLATION (FIGURE 2)

1. Before locating the unit on the roof, make sure that the strength of the roof and beams is adequate to support the weight involved. (See specification sheet for weight of units). This is very important and the installer's responsibility.
2. Make a proper consideration for weather-tight integrity of the roof and proper drainage of condensate.
3. To ensure proper condensate drainage, **unit must be installed in a level position.**
4. Consideration should also be given to shade, appearance, and noise.

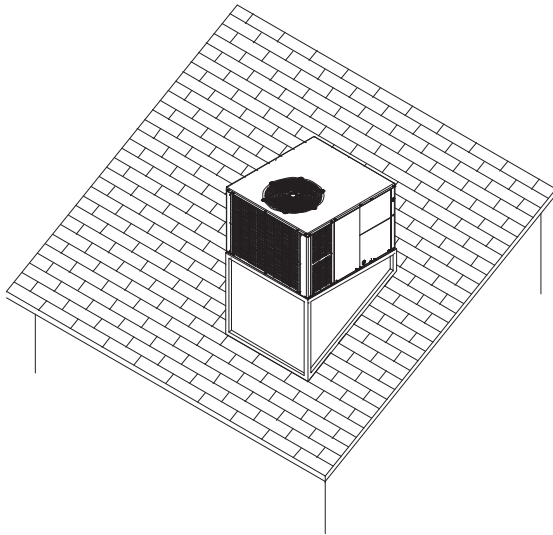

FIGURE 2: ROOFTOP INSTALLATION

ROOF CURB INSTALLATIONS

NOTE: SUFFICIENT STRUCTURAL SUPPORT MUST BE DETERMINED PRIOR TO LOCATING AND MOUNTING THE CURB AND PACKAGE UNIT.

Curb insulation, cant strips, flashing and general roofing material are furnished by the contractor.

Curbing must be installed in compliance with the National Roofing Contractors Association Manual. Construct duct work using current industry guidelines. The duct work must be placed into the roof curb before mounting the package unit. See FIGURE 3: ROOFCURB INSTALLATION.

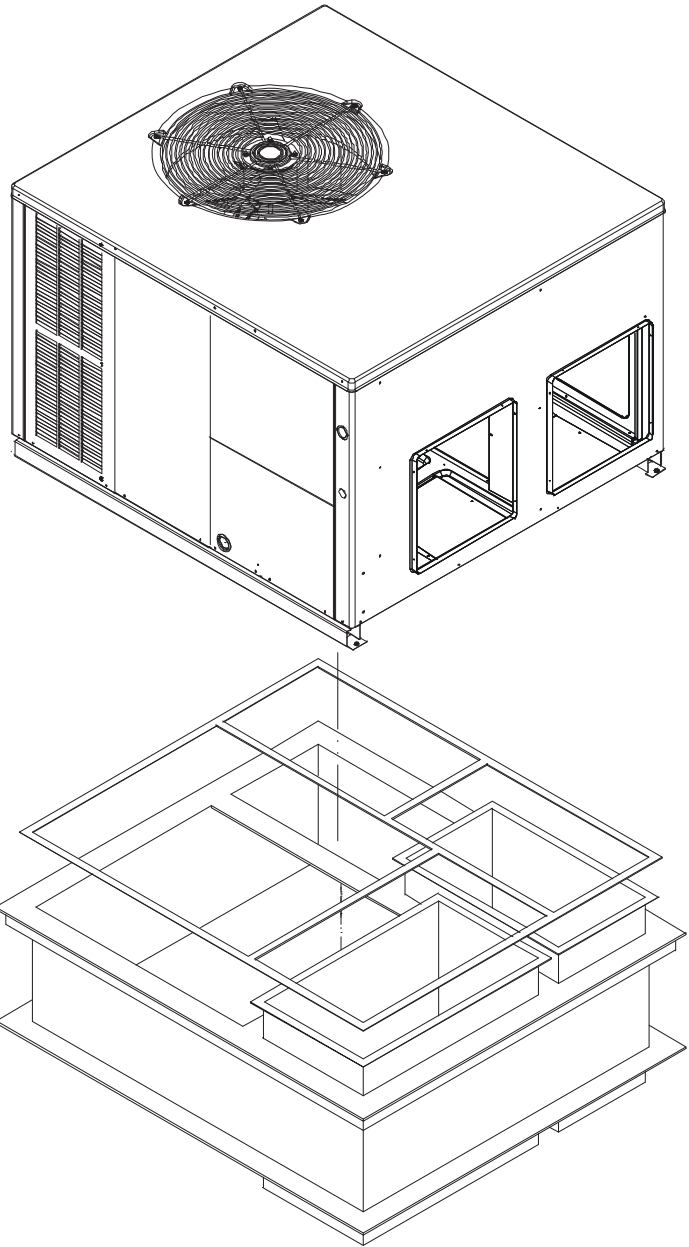



FIGURE 3: ROOFCURB INSTALLATION

RIGGIN DETAILS

 WARNING
<p>TO PREVENT PROPERTY DAMAGE, THE UNIT SHOULD REMAIN IN AN UPRIGHT POSITION DURING ALL RIGGING AND MOVING OPERATIONS. TO FACILITATE LIFTING AND MOVING WHEN CRANE IS USED, PLACE THE UNIT IN AN ADEQUATE CABLE SLING.</p>
 CAUTION
<p>IF UNITS ARE LIFTED TWO AT A TIME, THE FORK HOLES ON THE CONDENSER END OF THE UNIT MUST NOT BE USED. MINIMUM FORK LENGTH IS 42" TO PREVENT DAMAGE TO THE UNIT; HOWEVER, 48" IS RECOMMENDED.</p>

NOTE: PROVISIONS FOR FORKS HAVE BEEN INCLUDED IN THE UNIT BASE FRAME. NO OTHER FORK LOCATIONS ARE APPROVED.



WARNING

TO AVOID POSSIBLE PROPERTY DAMAGE, PERSONAL INJURY OR DEATH, ENSURE THE ROOF HAS SUFFICIENT STRUCTURAL STRENGTH TO CARRY THE WEIGHT OF THE UNIT(S), ROOFCURB, SNOWLOADS, AND WATER LOADS AS REQUIRED BY LOCAL CODES. CONSULT A STRUCTURAL ENGINEER TO DETERMINE THE WEIGHT CAPABILITIES OF THE ROOF.



CAUTION

TO AVOID POSSIBLE PERSONAL INJURY, A SAFE, FLAT SURFACE FOR SERVICE PERSONNEL SHOULD BE PROVIDED.



WARNING

TO PREVENT POSSIBLE EQUIPMENT DAMAGE, PROPERTY DAMAGE, PERSONAL INJURY OR DEATH, THE FOLLOWING BULLET POINTS MUST BE OBSERVED WHEN INSTALLING THE UNIT.

Unit must be lifted by the four lifting holes located at the base frame corners. See Figure 4: Rigging

- Lifting cables should be attached to the unit with shackles
- The distance between the crane hook and the top of the unit must not be less than 60".
- Two spreader bars must span over the unit to prevent damage to the cabinet by the lift cables. Spreader bars must be of sufficient length so that cables do not come into contact with the unit during transport.
- Remove wood struts mounted beneath unit base frame before setting unit on roof curb. These struts are intended to protect unit base frame from forklift damage. Removal is accomplished by extracting the sheet metal retainers and pulling the struts through the base of the unit. Refer to rigging label on the unit.

Refer to the Roof Curb Installation Instructions for proper curb installation. Curbing must be installed in compliance with the National Roofing Contractors Association Manual.

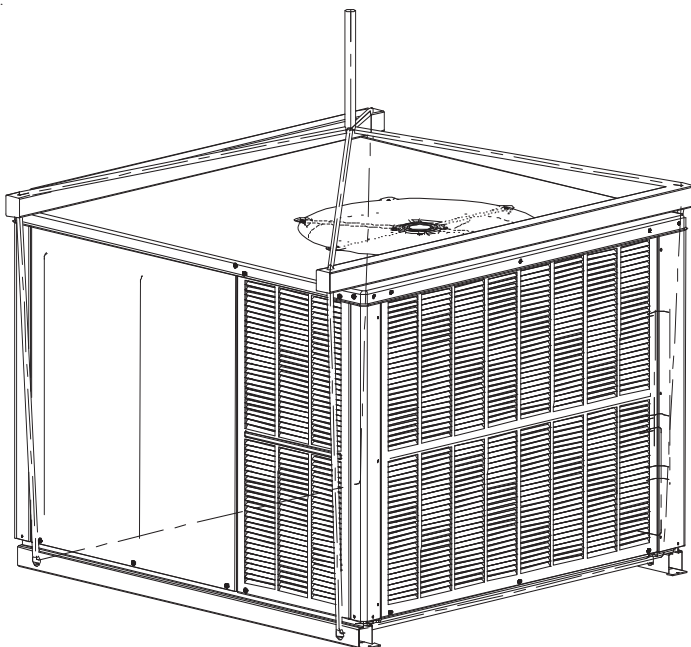

FIGURE 4: RIGGING

CIRCULATING AIR AND FILTERS

AIRFLOW CONVERSION

Units can easily be converted from horizontal to down discharge air flow delivery. See FIGURE 5a: HORIZONTAL FLOW DUCT COVER INSTALLATION and FIGURE 5b: DOWNFLOW DUCT COVER INSTALLATION. In down discharge or high static installations, the installer should measure the total external static and review the blower performance charts before performing the installation. In some installations it will be necessary to change the blower speed to provide proper air flow.

Horizontal Air Flow

Single phase models are shipped without horizontal duct covers. If needed, these kits may be ordered through Goodman's Service Parts department.

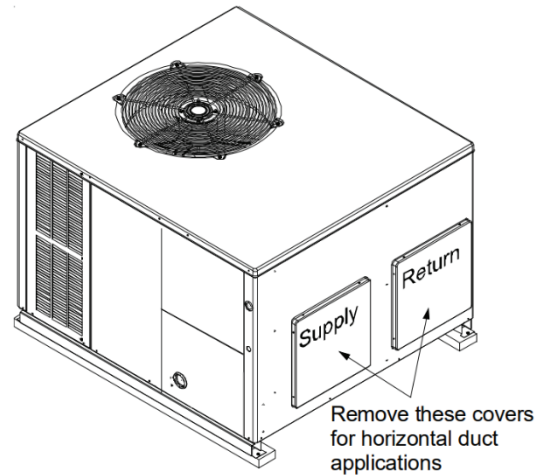

FIGURE 5A: HORIZONTAL FLOW DUCT COVER INSTALLATION

Down Discharge Applications

Cut insulation around bottom openings and remove panels from the bottom of the unit, saving the screws holding the panels in place.

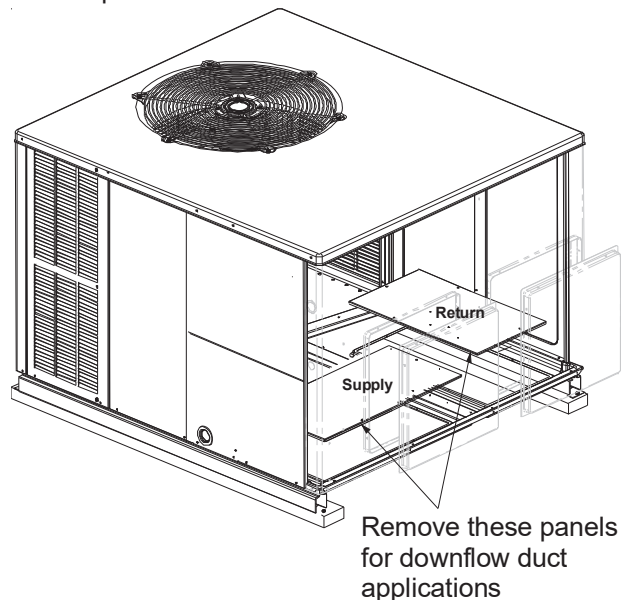

FIGURE 5B: DOWNFLOW DUCT COVER INSTALLATION

DUCTING

Ducting work should be fabricated by the installing contractor in accordance with local codes. Industry manuals may be used as a guide when sizing and designing the duct system-such as NESCA (National Environmental Systems Contractors Association, 1501 Wilson., Arlington, Virginia 22209).

The unit should be placed as close as possible to the space to be air-conditioned allowing clearance dimensions as indicated. Ducts should run as directly as possible to supply and return outlets. Use of non-flammable weatherproof flexible connectors on both supply and return connections at the unit to reduce noise transmission is recommended.

It is preferable to install the unit on the roof of the structure if the registers or diffusers are in the wall or ceiling. A slab installation is recommended when the registers are low on the wall or in the floor.

CONNECTING THE RETURN AND SUPPLY FLEXIBLE DUCT IN MANUFACTURED OR MODULAR HOUSING APPLICATION.

The return and supply fittings are to be attached at the unit to a suitable square to round duct converter. Your distributor has a factory designed square to round converter transition. The model #'s of these kits are as follows in the table below. (See Specification Sheets for Dimension details).

ACCESSORY DESCRIPTION	ITEM NUMBER	
	MEDIUM CHASSIS	LARGE CHASSIS
Downflow Square to Round	SQRPG101/102	SQRPG103
Horizontal Square to Round	SQRPGH102	SQRPGH103

The SQRPG101, SQRPG102, and SQRPG103 fit up to the Return and Supply Downflow vents having dimensions: Return (22 3/4" x 12 1/4") and Supply (22 1/4" x 14 3/4"). The SQRPGH101, SQRPGH102, and SQRPGH103 fit up to the Horizontal Return and Supply downflow vents having dimensions: Medium Chassis (16 1/2" x 16 1/2") and Large Chassis (18 1/2" x 18 1/2"). The Medium Chassis kits transition to a 16" Diameter and the Large Chassis kits transition to an 18" Diameter (equivalent diameter, opening is oval) on the return. The collars are to be slipped into the openings, and the flanges bent around the converter. The square to round converter is attached to the flanges of the square duct openings. The flexible duct is then clamped on to the collars. Once the duct is affixed to the unit, seal the collars and flanges with a proper waterproof sealant. SEE FIGURE 6: MANUFACTURED HOME MODIFICATION KIT.

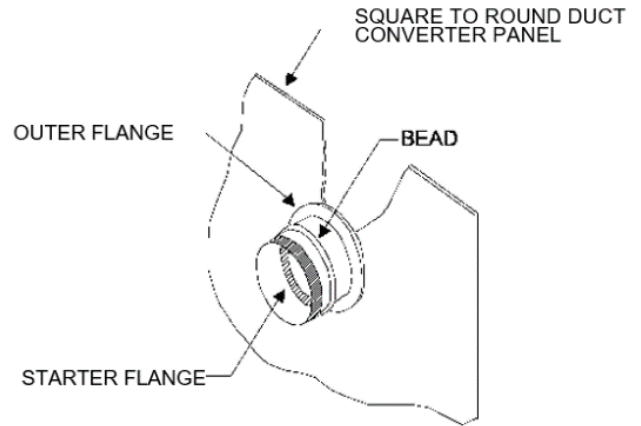

FIGURE 6: MANUFACTURED HOME MODIFICATION KIT

It is strongly encouraged to use appropriately sized ducts based upon the CFM for your application (unit's CFM). If duct sizing through industry manuals or air duct calculators requires larger ducts than converter openings, run larger duct size up to unit converter openings and reduce with a reducer duct fitting or transition right at the unit.

PLENUM APPLICATION

A suitable plenum or square duct must be constructed. The duct cross-sectional area should be determined by industry duct sizing manuals or air duct calculators.

On ductwork exposed to outside air conditions of temperature and humidity, use an insulation with a good K factor, and a vapor barrier. Industry practices should be followed. Balancing dampers are recommended for each branch duct in the supply system. Ductwork should be properly supported from the unit.

NOTE: PROPER SEALING OF ALL DUCTWORK AND AIR HANDLING COMPARTMENTS IS EXTREMELY IMPORTANT TO OVERALL UNIT EFFICIENCY.

FILTERS

Filters are not provided with unit and must be supplied and externally installed in the return duct system by the installer. A field-installed filter grille is recommended for easy and convenient access to the filters for periodic inspection and cleaning. When installing filters, ensure the air flow arrows on the filter are pointing toward the circulator blower. For unit filter size information, see table below for recommended filter size.

UNIT	2 TON	2 1/2 TON	3 TON	3 1/2 TON	4 TON	5 TON
Min. Filter Size	(1)25X25X1	(1)25X25X1	(1)25X25X1	(1)25X25X1	(2)20X20X1	(2)20X20X1

CONDENSATE DRAIN PIPING

The condensate drain connection of the evaporator is a 3/4" NPT half coupling. A trap must be provided to have proper condensate draining. Install condensate drain trap as shown in FIGURE 9: CONDENSATE DRAIN TRAP PLUMBING. Ensure drain connection is 3/4" or larger. Do not operate unit without trap and ensure unit is level or slightly inclined toward drain.

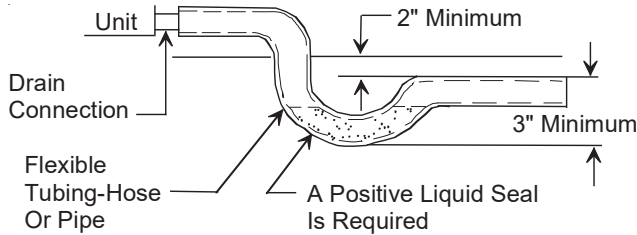

FIGURE 9: CONDENSATE DRAIN TRAP PLUMBING

ELECTRICAL WIRING



CAUTION

TO AVOID PROPERTY DAMAGE OR PERSONAL INJURY DUE TO FIRE, USE ONLY COPPER CONDUCTORS.

All wiring should be made in accordance with the National Electrical Code. The local power company should be consulted to determine the availability of sufficient power to operate the unit. The voltage, frequency, and phase at the power supply should be checked to make sure it corresponds to the unit's RATED VOLTAGE REQUIREMENT.

Install a branch circuit fused disconnect near the unit, in accordance with the N.E.C. or local codes. Wire sizes and overcurrent protection should be determined from the unit nameplate ampacity and in accordance with N.E.C. and local building codes. Under no circumstances should wiring be sized smaller than is recommended by either of these two sources.

Fuses smaller than that recommended on the unit nameplate could result in unnecessary fuse failure or service calls. The use of protective devices of larger size than indicated could result in extensive damage to the equipment. The manufacturer bears no responsibility for damage caused to equipment as result of the use of larger than is recommended size protective devices.

All units have undergone a run test prior to packaging for shipment. This equipment has been started at minimum rated voltage and check for satisfactory operation. Do not attempt to operate this unit if the voltage is not within the minimum and maximum voltages shown on the nameplate.

The units are designed for operation at the voltage, frequency and phase as shown on the rating plate. All internal wiring in the unit is complete. It is necessary to bring in the power supply to the contactor as shown on the unit wiring diagram which is supplied with each unit. The low voltage wiring must be connected between the unit control panel and the room thermostat.

All exterior wiring must be within approved weatherproof conduit. The unit must be **permanently grounded** in accordance with local codes, or in absence of local codes with N.E.C. ANSI/NFPA NO. 70-1984 or latest edition by using ground lug in the control box.

DO NOT EXCEED THE MAXIMUM OVERCURRENT DEVICE SIZE SHOWN ON UNIT DATA PLATE.

Fuses or HACR type circuit breakers may be used where codes permit.

IMPORTANT NOTE: UNITS MAY BE EQUIPPED WITH A SINGLE POLE CONTACTOR. CAUTION MUST BE EXERCISED WHEN SERVICING AS ONLY ONE LEG OF THE POWER SUPPLY IS BROKEN WITH THE CONTACTOR.

Rated Voltage	Minimum Supply Voltage	Minimum Supply Voltage
208/230V	197	253



WARNING

HIGH VOLTAGE!
DISCONNECT ALL POWER BEFORE SERVICING OR INSTALLING THIS UNIT. MULTIPLE POWER SOURCES MAY BE PRESENT. FAILURE TO DO SO MAY CAUSE PROPERTY DAMAGE, PERSONAL INJURY OR DEATH.



CAUTION

TO AVOID THE RISK OF ELECTRICAL SHOCK, WIRING TO THE UNIT MUST BE POLARIZED AND GROUNDED.

HIGH VOLTAGE WIRING

Single phase – Connect two leads to terminals L1 & L2 in the electrical control section, using wire sizes specified in wiring table.

Branch Circuit Ampacity	15	20	25	30	35	40	45	50
SUPPLY WIRE LENGTH - FEET								
200	6	4	4	4	3	3	2	2
150	8	6	6	4	4	4	3	3
100	10	8	8	6	6	6	4	4
50	14	12	10	10	8	8	6	6

FIGURE 8: WIRING TABLE

NOTE: THE UNIT TRANSFORMER IS FACTORY CONNECTED FOR 240V OPERATION. IF THE UNIT IS TO OPERATE ON 208V, RECONNECT THE TRANSFORMER PRIMARY LEAD AS SHOWN ON THE UNIT WIRING DIAGRAM.

LOW VOLTAGE WIRING

Air Conditioners – Connect 24V wires from the thermostat to the corresponding wires in the control box using No. 18 AWG as follows:

DP3CM	
Terminal	Thermostat
Red	R (24V)
Green	G (fan)
Yellow	Y (Cool)
White	W1 (Heat, Aux Heat Stage 1)*
Brown	W2 (Heat, Aux Heat Stage 2)*
Blue	C (Common)
*Optional field installed heat connections	

Heat Pumps – Connect 24V wires from the thermostat to the corresponding wires in the control box using No. 18 AWG as follows:

NOTE: DP3HM6041 UNIT HAS TWO-STAGE HEATING/ COOLING AND REQUIRE THERMOSTATS WITH TWO-STAGE HEAT/COOL AND OPTIONAL AUXILIARY HEAT CONTROL.

DP3HM	
Terminal	Thermostat
Red	R (24V)
Green	G (fan)
Orange	O (Rev. Valve)
White	W1 (Heat, Aux Heat Stage 1)*
Brown	W2 (Heat, Aux Heat Stage 2)*
Yellow	Y (Compressor)
Blue	C (24V Common)
*Optional field installed heat connections	
Thermostats must be set to energize “G” during cooling. This is default on most thermostats.	

INTERNAL WIRING

A diagram detailing the internal wiring of this unit is located on the electrical box cover. If any of the original wire supplied with the appliance must be replaced, the wire gauge and insulation must be the same as the original wiring.



1. For branch circuit wiring (main power supply to unit disconnect), the minimum wire size for the length of the run can be determined from N.E.C., local building codes, and using the circuit ampacity found on the unit rating plate. From the unit disconnect to unit, the smallest wire size allowable may be used for the ampacity, **as the Disconnect MUST be in accordance with federal, state, and local**

jurisdiction requirements.

2. Wire size based on 60°C rated wire insulation and 30°C Ambient Temperature (86°F).
3. For more than 3 conductors in a raceway or cable, see the N.E.C. for derating the ampacity of each conductor.



START-UP PROCEDURES AND CHECKLISTS

Begin with power turned off at ALL disconnects.

	WARNING
<p>HIGH VOLTAGE! DISCONNECT ALL POWER BEFORE SERVICING OR INSTALLING THIS UNIT. MULTIPLE POWER SOURCES MAY BE PRESENT. FAILURE TO DO SO MAY CAUSE PROPERTY DAMAGE, PERSONAL INJURY OR DEATH.</p>	
	

AIR CONDITIONER START-UP PROCEDURE

1. Turn thermostat system switch to “Cool,” and fan switch to “Auto” and turn temperature setting as high as it will go.
2. Inspect all registers and set them to the normal open position.
3. Turn on the electrical supply at the disconnect.
4. Turn the fan switch to the “ON” position. The blower should operate after a 10 second delay.
5. Turn the fan switch to “AUTO” position. The blower should begin ramping down after an approximate 60-second delay.
6. Slowly lower the cooling temperature until the unit starts. The compressor, blower, and fan should now be operating. Allow the unit to run 10 minutes, make sure cool air is being supplied by the unit.
7. Turn the temperature setting to the highest position, stopping the unit. The indoor blower will continue to run for approximately 60 seconds.
8. Turn the thermostat system switch to “OFF” and disconnect all power when servicing the unit.

	WARNING
<p>HIGH VOLTAGE! DISCONNECT ALL POWER BEFORE SERVICING OR INSTALLING THIS UNIT. MULTIPLE POWER SOURCES MAY BE PRESENT. FAILURE TO DO SO MAY CAUSE PROPERTY DAMAGE, PERSONAL INJURY OR DEATH.</p>	
	

HEAT PUMP START-UP PROCEDURE

1. Check the cooling mode for the heat pump in the same manner as above. The reversing valve is energized when the thermostat is placed in the cooling position. A clicking sound should be noticeable from the reversing valve. By lowering the temperature setting to call for cooling, the contactor is energized. The compressor, blower and fan should then be running. After the colling mode is checked out, turn the thermostat system switch to “OFF”.

2. Turn the thermostat system switch to “HEAT” and fan switch to “AUTO”.
3. Slowly raise the heating temperature setting. When the heating first stage makes contact, stop raising the temperature setting. The compressor, blower and fan should now be running with the reversing valve in the de-energized (heating) position. After giving the unit time to settle out, make sure the unit is supplying heated air.
4. If the outdoor ambient is above 80°F, the unit may trip on its high-pressure cutout when in heating mode. The compressor should stop. The heating cycle must be thoroughly checked, so postpone the test to another day when conditions are more suitable but, **DO NOT FAIL TO TEST.**
5. If unit operates properly in the heating cycle, raise the temperature setting until the heating second stage makes contact. Supplemental resistance heat, if installed should now come on. Make sure it operates properly.

NOTE: 5-TON 13.4 SEER2 MODELS HAVE TWO STAGES OF COMPRESSOR HEAT. DURING RESISTANCE HEAT TEST, INCREASE TEMPERATURE SETTING UNTIL THIRD STAGE HEAT IS ENERGIZED.

NOTE: IF OUTDOOR THERMOSTATS ARE INSTALLED THE OUTDOOR AMBIENT MUST BE BELOW THE SET POINT OF THESE THERMOSTATS FOR THE HEATERS TO OPERATE. IT MAY BE NECESSARY TO JUMPER THESE THERMOSTATS TO CHECK HEATER OPERATION IF OUTDOOR AMBIENT IS MILD.

NOTE: IF THE OUTDOOR AMBIENT IS LOW AND THE UNIT OPERATES PROPERLY IN THE HEATING CYCLE, YOU MAY CHECK THE PRESSURE CUTOUT OPERATION BY BLOCKING OFF THE INDOOR RETURN AIR UNTIL THE UNIT TRIPS. IF UNIT OPERATES PROPERLY IN THE HEATING CYCLE, RAISE THE TEMPERATURE SETTING UNTIL THE HEATING SECOND STAGE MAKES CONTACT. SUPPLEMENTAL RESISTANCE HEAT, IF INSTALLED SHOULD NOW COME ON. MAKE SURE IT OPERATES PROPERLY.

6. THERMOSTATS WITH EMERGENCY HEAT. For thermostats with an emergency heat switch, raise the temperature setting until the heating second stage makes contact. The emergency heat switch is located at the bottom of the thermostat. Move the switch to emergency heat. The heat pump will stop, the blower will continue to run, all heaters will come on and the thermostat emergency heat light will come on.
7. If checking the unit in the wintertime, when the outdoor coil is cold enough to actuate the defrost control, observe at least one defrost cycle to make sure the unit defrosts completely.

FINAL SYSTEM CHECK

1. Check to see if all supply and return air grilles are adjusted and the air distribution system is balanced for the best compromise between heating and cooling.
2. Check for air leaks in the ductwork.
3. Check air flow and refrigerant charge. See Sections on **Air Flow Measurement and Adjustment** and

Checking Charge.

4. Ensure the unit is free of “rattles”, and the tubing in the unit is free from excessive vibration. Also make sure tubes or lines are not rubbing against each other or sheet metal surfaces or edges. If discovered, ensure issue is corrected.
5. Set the thermostat at the appropriate setting for cooling and heating or automatic changeover for normal use.
6. Ensure the Owner is instructed on the unit operation, filter, servicing, correct thermostat operation, etc.

NOTE: THE “AIR CONDITIONER START-UP PROCEDURE” IS A RECOMMENDED STEP AS IT SERVES AS A SYSTEM INDICATOR THAT THE UNIT WILL OPERATE NORMALLY.

COMPONENTS

Contactor – This control is activated (closed) by the room thermostat for both heating and cooling. The contactor has a 24V coil and supplies power to the compressor and outdoor fan motor.

Crankcase Heater – This item is “ON” whenever power is supplied to the unit and crankcase heater thermostat is closed. Crankcase heater thermostat closes at 67° and opens at 85°. It warms the compressor crankcase thereby preventing liquid migration and subsequent compressor damage. The insert type heater is self-regulating. It is connected electrically to the contactor L1 & L2 terminals.

Condenser Motor – This item is activated by the contactor during heating and cooling, except during defrost and emergency heat operation. On 460V heat pumps, the condenser motor is activated by the CMR.

Compressor – This item is activated by the contactor for heating and cooling, except during emergency heat. It is protected by an internal overload.

Contactor Relay – This control is activated by the thermostat (24V coil) and supplies power to the contactor.

Defrost Control – The Defrost control provides time/temperature initiation and termination of the defrost cycle. When a Defrost cycle is initiated, the defrost control shifts the reversing valve to “cooling” mode, stops the outdoor fan and brings on supplemental heat. Normally, a Defrost cycle will take only 2-3 minutes unless system is low on charge or outdoor conditions are severe. (Windy and cold). The defrost control also provides for a 3 minute off cycle compressor delay.

Outdoor Thermostat – These optional controls are used to prevent full electric heater operation at varying outdoor ambient (0°F to 45°F). They are normally open above their set points and closed below to permit staging of indoor supplement heater operation. If the outdoor ambient temperature is below 0°F (-18°C) with 50% or higher RH, an outdoor thermostat (OT) must be installed and set at (0°F) on the dial. Failure to comply with this requirement may result in damage to the product which may not be covered by the manufacturer’s warranty.

Reversing Valve Coil – This coil is activated by the thermostat, in the cooling mode and during defrost. It positions the reversing valve pilot valve for cooling operation.

Indoor Blower Motor – Units with EEM Motors Only.

The EEM model indoor blower motor is activated by the room thermostat by cooling/HEATING or fan ON position. EEM motors are constant torque motors with low power consumption.

(See Air Flow Measurement and Adjustment for speed adjustment instructions).

Blower Interlock Relay – This relay is used to energize the blower during the electric heat operation. Some room thermostats do not energize the motor during electric heat. This relay ensures blower operation when the room thermostat energizes heat. This relay is energized by the electric heat kit sequencer.

HEAT PUMP OPERATION

COOLING CYCLE

When the heat pump is in the cooling cycle, it operates exactly as an Air Conditioner Unit. See Figure 9: HEAT PUMP COOLING SCHEMATIC

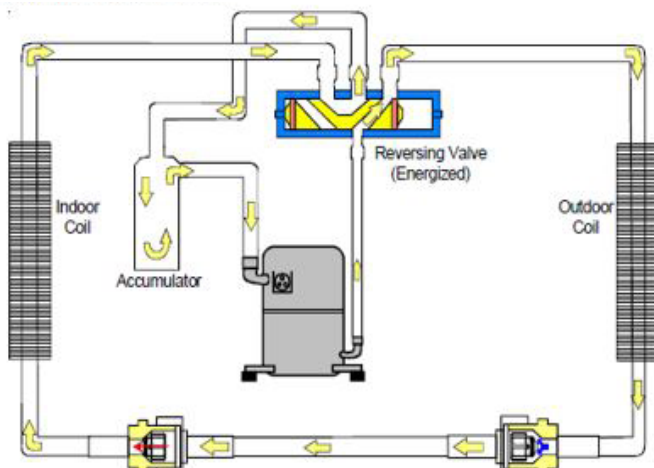

FIGURE 9: HEAT PUMP COOLING SCHEMATIC

HEATING CYCLE

The heat pump operates in the heating cycle by redirecting refrigerant flow through the refrigerant circuit external to the compressor. This is accomplished with the reversing valve. Hot discharge vapor from the compressor is directed to the indoor coil (evaporator on the cooling cycle) where the heat is removed, and the vapor condenses to liquid. It then goes through the expansion device to the outdoor coil (condenser on the cooling cycle) where the liquid is evaporated, and the vapor goes to the compressor.

When the solenoid valve coil is operated either from heating to cooling or vice versa, the piston in the reversing valve to the low pressure (high pressure) reverse positions in the reversing valve. The following figure, FIGURE 10: HEAT PUMP HEATING SCHEMATIC, shows a schematic of the heat pump in the heating cycle.

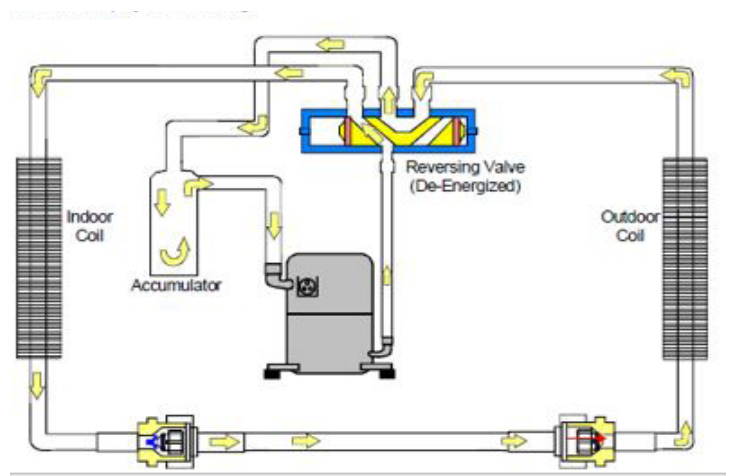

FIGURE 10: HEAT PUMP HEATING SCHEMATIC

For 5-Ton Heat Pump unit, the expansion devices are Thermal Expansion Devices (TXV) and perform the same function on the heating cycle as on the cooling cycle. The TXVs also act as check valves to allow for the reverse of refrigerant flow.

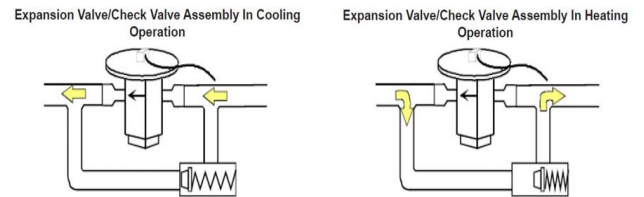

FIGURE 11

When the heat pump is on the heating cycle, the outdoor coil is functioning as an evaporator. The temperature of the refrigerant in the outdoor coil must be below the temperature of the outdoor air in order to extract heat from the air. Thus, the greater the difference in the outdoor temperature and the outdoor coil temperature, the greater the heating capacity of the heat pump. This phenomenon is a characteristic of a heat pump. It is a good practice to provide supplementary heat for all heat pump installations in areas where the temperature drops below 45° F. It is also a good practice to provide sufficient supplementary heat to handle the entire heating requirement should there be a component failure of the heat pump, such as a compressor, or refrigerant leak, etc.

Since the temperature of the liquid refrigerant in the outdoor coil on the heating cycle is generally below freezing point, frost forms on the surfaces of the outdoor coil under certain weather conditions of temperature and relative humidity. Therefore, it is necessary to reverse the flow of the refrigerant to provide hot gas in the outdoor coil to melt the frost accumulation. This is accomplished by reversing the heat pump to the cooling cycle. At the same time, the outdoor fan stops to hasten the temperature rise of the outdoor coil and lessen the time required for defrosting. The indoor blower continues to run, and the supplementary heaters are energized.

DEFROST CONTROL

During operation the power to the circuit board is controlled by a temperature sensor, which is clamped to a feeder tube entering the outdoor coil. Defrost timing periods of 30, 60 and 90 minutes may be selected by setting the circuit board jumper to 30, 60 and 90 respectively. Accumulation of time for the timing period selected starts when the sensor closes (approximately $30 \pm 5^\circ\text{F}$), and when the wall thermostat calls for heat. At the end of the timing period, the unit's defrost cycle will be initiated provided the sensor remains closed. When the sensor opens (approximately $60^\circ \pm 5^\circ\text{F}$), the defrost cycle is terminated and the timing period is reset. If the defrost cycle is not terminated due to the sensor temperature, a twelve-minute override interrupts the unit's defrost period.

SUGGESTED FIELD TESTING/TROUBLESHOOTING

TESTING DEFROST CONTROL

NOTE: PCBDM133 DEFROST CONTROLS HAVE A THREE (3) MINUTE COMPRESSOR OFF CYCLE DELAY.

NOTE: THE PCBDM133 DEFROST CONTROLS ARE SHIPPED FROM THE FACTORY WITH THE COMPRESSOR DELAY OPTION SELECTED. THIS WILL DE-ENERGIZE THE COMPRESSOR CONTACTOR FOR 30 SECONDS ON DEFROST INITIATION AND DEFROST TERMINATION. IF THE JUMPER IS SET TO NORMAL, THE COMPRESSOR WILL CONTINUE TO RUN DURING DEFROST INITIATION AND DEFROST TERMINATION. THE CONTROL WILL ALSO IGNORE THE LOW-PRESSURE SWITCH CONNECTED TO R-PS1 AND PS2 FOR 5 MINUTES UPON DEFROST INITIATION AND 5 MINUTES AFTER DEFROST TERMINATION.

To check the defrost control for proper sequencing, proceed as follows: With power ON; unit not running.

1. Jumper defrost thermostat by placing a jumper wire across the terminals "DFT" and "R"/" R-DFT" at defrost control board.
2. Remove jumper from timer pins and jump across test pins on defrost control board.
NOTE: Do not use screwdriver or field supplied jumper to test the control.
3. Set thermostat to call for heating. System should go into defrost within 21 seconds.
4. Immediately remove jumper from test pins.
5. Using VOM check for voltage across terminals "C & O". Meter should read 24 volts.
6. Using VOM check for voltage across fan terminals DF1 and DF2 on the board. Should read line voltage (208-230 VAC) indicating the relay is open in the defrost mode.
7. Using VOM check for voltage across "W"/"W2" & "C" terminals on the board. Should read 24 volts.
8. If not as above, replace control board.
9. Set thermostat to off position and disconnect power. Remove jumper from defrost thermostat and replace timer jumper to the desired defrost time.

NOTE: REMOVE JUMPER ACROSS DEFROST THERMOSTAT

BEFORE RETURNING SYSTEM TO SERVICE. SEE FIGURE 12: DEFROST CONTROL WIRING DIAGRAM.

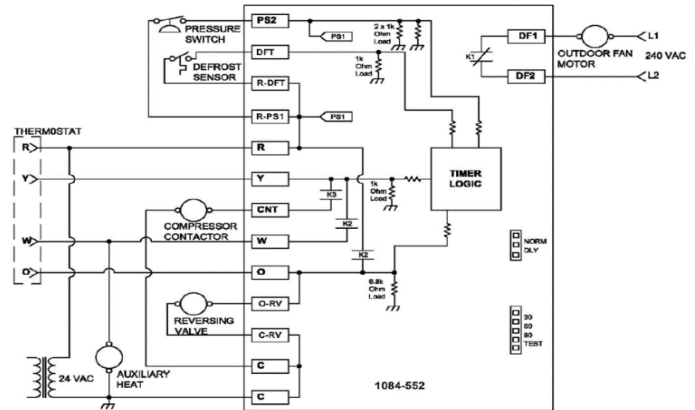

FIGURE 12: DEFROST CONTROL WIRING SCHEMATIC

TESTING DEFROST THERMOSTAT

1. Install a thermocouple type temperature test lead on the tube adjacent to the defrost control. Insulate the lead point of contact.
2. Check the temperature at which the control closes its contacts by lowering the temperature of the control. It should close at approximately 30°F .
3. Check the temperature at which the control opens its contacts by raising the temperature of the control. It should open at approximately 60°F . If not as above, replace control.

AIR FLOW MEASUREMENT AND ADJUSTMENT

After reviewing section on DUCTING, proceed with airflow measurements and adjustments. Unit's blower curves (in Specification Sheets) are based on external static pressure (ESP, in. of W.C.). The duct openings on the unit are considered internal static pressure, so long as ESP is maintained, the unit will deliver the proper air up to the maximum static pressure listed for the CFM required by the application (i.e., home, building, etc.).

In general, 400 CFM per ton of cooling capacity is a rule of thumb. Some applications depending on the sensible and latent capacity requirements may need only 350 CFM or up to 425 CFM per ton. Check condition space load requirements (from load calculations) and equipment expanded ratings data to match CFM and capacity. After unit is set and ducted, verify ESP with a 1" inclined manometer with pitot tubes or a Magnahelic gauge and confirm CFM to blower curves in the specification sheets. All units have multiple speed blower motors. If factory selected speed is not utilized, the speed tap can be changed.

NOTE: NEVER RUN CFM BELOW 300 CFM PER TON, EVAPORATOR FREEZING, OR POOR UNIT PERFORMANCE IS POSSIBLE.

TOTAL EXTERNAL STATIC PRESSURE

1. Using a digital manometer measure the static pressure of the return duct at the inlet of the unit (Negative Pressure). SEE FIGURE 13: TOTAL EXTERNAL STATIC.
2. Measure the static pressure of the supply duct (Positive Pressure).
3. Add the two readings together

NOTE: BOTH READINGS MAY BE TAKEN SIMULTANEOUSLY AND READ DIRECTLY ON THE MANOMETER IF SO DESIRED.

4. Consult proper table for quantity of air.

If the external static pressure exceeds the minimum or maximum allowable statics, check for closed dampers, dirty filter, undersized or poorly laid out ductwork.

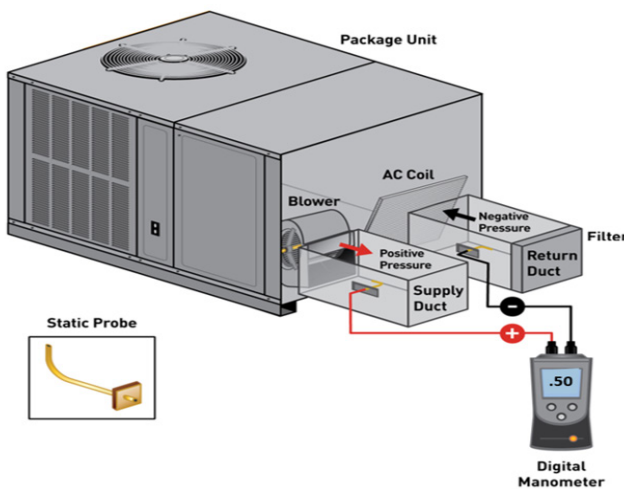

FIGURE 13: TOTAL EXTERNAL STATIC

ADJUSTING SPEED TAP FOR INDOOR BLOWER MOTOR

EEM MOTOR

The blower motor speed for the EEM motor is controlled by three 24V low voltage leads: green, yellow, and white. The green lead sets the speed for fan-only mode. The yellow lead sets the speed for cooling and heat pump heating mode (if applicable).

EEM MOTOR SPEED ADJUSTMENT

The white lead sets the speed for electric heat mode (emergency heat and second stage heat, if applicable). The leads are factory connected as follows: Green to T1, Yellow to T2, and White to T3. T1 is the low speed setting and is dedicated to fan-only mode. T2 is medium speed cooling and T3 is medium speed heating. T4 is high speed cooling and T5 is high speed heating. To adjust the blower speed, move the yellow and/or white wires to T4 and T5.

NOTE: IF MORE THAN ONE LEAD IS ENERGIZED AT THE SAME TIME, THE MOTOR WILL USE THE HIGHER SPEED SETTING.

See appendix for Blower Performance Data tables.

DP3HM CFM DELIVERY AND ADJUSTMENTS

See Appendix for CFM Output, Adjustments, and DIP switch settings.

DP3HM THERMOSTAT "FAN ONLY" MODE

During Fan Only Operations, the CFM output is 50% of the high stage cooling setting.

SUPERHEAT AND SUBCOOLING

CHECKING SUBCOOLING

NOTE: UNITS WITH A TXV SHOULD BE CHARGED TO SUBCOOLING ONLY.

EXAMPLE:

- a. Liquid Line Pressure = 417 PSI
- b. Corresponding Temp. = 120°F
- c. Thermometer on Liquid line = 109°F.

To obtain the amount of subcooling, subtract 109°F from 120°F. The difference is 11° subcooling. See the specification sheet or technical information manual for the design subcooling range for your unit.

SUBCOOLING FORMULA = SATURATED LIQUID LINE TEMPERATURE - LIQUID LINE TEMPERATURE

CHECKING SUPERHEAT

EXAMPLE:

- a. Suction Pressure = 143 PSI
- b. Corresponding Temp. = 50°F
- c. Thermometer on Suction Line = 59°F

To obtain the degrees temperature of superheat, subtract 50.0 from 59.0°F. The difference is 9° Superheat. The 9° Superheat would fall in the ± range of allowable superheat.

SUPERHEAT = SUCTION LINE TEMP - SAT. SUCTION TEMP.

SUPERHEAT ADJUSTMENT

NOTE: SUPERHEAT ADJUSTMENTS SHOULD NOT BE MADE UNTIL INDOOR AMBIENT CONDITIONS HAVE STABILIZED. THIS COULD TAKE UP TO 24 HOURS DEPENDING ON INDOOR TEMPERATURE AND HUMIDITY. BEFORE CHECKING SUPERHEAT, RUN THE UNIT IN COOLING FOR 10-15 MINUTES OR UNTIL REFRIGERANT PRESSURES STABILIZE. USE THE FOLLOWING GUIDELINES AND METHODS TO CHECK UNIT OPERATION AND ENSURE THAT THE REFRIGERANT CHARGE IS WITHIN LIMITS.

For TXV systems, to adjust superheat, unscrew the cover from the expansion valve, locate the adjustment screw, and turn it clockwise (in) to increase superheat or counterclockwise (out) to decrease superheat. It is recommended to make small adjustments at a time, 1/8-1/4 turn increments. Replace adjustment cap. Wait a minimum of 10 minutes between adjustments to allow time for the TXV and pressures to stabilize.

Design Superheat & Subcooling					
Model	Superheat ±2°F	Subcooling ±1°F	Expansion Device	Cooling Stage	Outdoor ambient (°F)
DP3CM364*	7	10	Piston	High	95
DP3CM484*	5	13	Piston	High	95
DP3CM604*	14	16	TXV	High	95
DP3HM244*	15	12	Piston	High	95
DP3HM304*	10	9	Piston	High	95
DP3HM364*	6	9	Piston	High	95
DP3HM424*	12	6	Piston	High	95
DP3HM484*	12	10	Piston	High	95
DP3HM604*	4	8	TXV	Low	82

FIGURE 14: DESIGN SUPERHEAT AND SUBCOOLING

REFRIGERANT CHARGE CHECK

NOTE: FOR OPTIMAL PERFORMANCE, FOLLOW CHARGING INSTRUCTIONS BELOW.

Units with Fixed Orifice Devices

All package units with fixed orifice devices are charged using the superheat method at the compressor suction line. To increase super heat, remove charge and to decrease super heat, add charge. After superheat is adjusted, it is recommended to check unit subcooling at the condenser coil liquid line. See Figure 14: DESIGN SUPERHEAT AND SUBCOOLING table for targets on each model.

Units with Expansion valve (TXV)

Single Stage Cooling Application: Refer to the Design Superheat & Subcooling table

Two-Stage Cooling Application: Run unit on Low Stage cooling and refer to Design Superheat & Subcooling table.

1. Purge gauge lines. Connect service gauge manifold to access fittings. Run system at least 10 minutes to allow pressure to stabilize.
2. Temporarily install thermometer on liquid (small) line near liquid line access fitting with adequate contact and insulate for best possible reading.
3. Check subcooling and superheat. System should have a subcooling and superheat within the range listed on the Design Superheat and Subcooling table.
 - a. If subcooling and superheat are low, adjust TXV superheat, then check subcooling.

NOTE: To adjust superheat, turn the valve stem clockwise to increase and counterclockwise to decrease.
 - b. If subcooling is low and superheat is high, add charge to raise subcooling then check superheat.
 - c. If subcooling and superheat are high, adjust TXV valve superheat, then check subcooling.
 - d. If subcooling is high and superheat is low, adjust TXV valve superheat and remove charge to lower the subcooling.

NOTE: Do NOT adjust the charge based on suction pressure unless there is a gross undercharge.
4. Disconnect manifold set, installation is complete.

ELECTRICAL HEAT INSTALLATION & ADJUSTMENT

HEATER KIT

NOTE: A SEPARATE POWER SUPPLY IS REQUIRED FOR HKR/HKP HEATER KITS

Refer to the specification manual for heater kit match up and Heater Kit Electrical Data.

This series of electric cooling and heat pump package equipment is designed to accept a field installed electric heat kit. The unit is equipped to easily install the HKR/HKP Series Electric Heat Kit. Full Installation Instructions are included in this kit. Please use this document for guidance in field equipping the package unit with electric heat. Choose the heat kit that fits the application for the specific installation. Permanently mark the unit's nameplate with the model being installed.

High and low voltage connections are detailed in the heat kit instructions. Indoor Blower motor speed tap selection may need to be modified to accommodate normal continuous operation to prevent a nuisance trip. See below FIGURE 15: ELECTRIC HEAT kW.

Model	Electric Heat kW				
	5	8	10	15	20
DP3HM2441	M _(F)	M _(F)	M _(F)	H	N/A
DP3HM3041	M _(F)	M _(F)	M _(F)	H	N/A
DP3HM3641	M	M	H _(F)	H _(F)	N/A
DP3HM4241	M	M	H _(F)	H _(F)	N/A
DP3HM4841	3 _(F)	3 _(F)	3 _(F)	3 _(F)	3 _(F)
DP3HM6041	3 _(F)	3 _(F)	3 _(F)	3 _(F)	3 _(F)



*(F) - Factory Setting

Speed Taps Description: (H) / 4,5 - High; (M) 2,3 - Medium; (L)/1 - Low

1/2/3/4/5: EEM motor

FIGURE 15: ELECTRIC HEAT kW

MAINTENANCE

 <p>WARNING</p>	
<p>HIGH VOLTAGE! DISCONNECT ALL POWER BEFORE SERVICING OR INSTALLING THIS UNIT. MULTIPLE POWER SOURCES MAY BE PRESENT. FAILURE TO DO SO MAY CAUSE PROPERTY DAMAGE, PERSONAL INJURY OR DEATH.</p>	

The Self-Contained Package Air Conditioner and Heat Pump should operate for many years without excessive service calls if the unit is installed properly. However, it is recommended that the homeowner inspect the unit before a seasonal start up. The coils should be free of debris so adequate airflow is achieved. The return and

supply registers should be free of any obstructions. The filters should be cleaned or replaced. These few steps will help to keep the product up time to a maximum. The Troubleshooting Chart (see Appendix) should help in identifying problems if the unit does not operate properly.

SERVICE

THE FOLLOWING INFORMATION IS FOR USE BY QUALIFIED SERVICE AGENCY ONLY: OTHERS SHOULD NOT ATTEMPT TO SERVICE THIS EQUIPMENT.

Common Causes of Unsatisfactory Operation of Heat Pump on the Heating Cycle.

INADEQUATE AIR VOLUME THROUGH INDOOR COIL

When a heat pump is in the heating cycle, the indoor coil is functioning as a condenser. The return air filter must always be clean, and sufficient air volume must pass through the indoor coil to prevent excessive discharge pressure, and high pressure cut out.

OUTSIDE AIR INTO RETURN DUCT

Do not introduce cold outside air into the return duct of a heat pump installation. Do not allow air entering the indoor coil to drop below 65°F. Air below this temperature will cause low discharge pressure, thus low suction pressure, and excessive defrost cycling resulting in low heating output. It may also cause false defrosting.

MALFUNCTIONING REVERSING VALVE

This may be due to:

1. **Solenoid not energized** – In order to determine if the solenoid is energized, touch the nut that holds the solenoid cover in place with a screwdriver. If the nut magnetically holds the screwdriver, the solenoid is energized, and the unit is in the cooling cycle.
2. **No voltage at unit's solenoid** – Check unit voltage. If no voltage, check wiring circuit.
3. **Valve will not shift:**
 - a. **Undercharged** – Check for leaks.
 - b. **Valve Body Damaged** – Replace valve.
 - c. **Unit Properly Charged** – If it is on the heating cycle, raise the discharge pressure by restricting airflow through the indoor coil. If the valve does not shift, tap it lightly on both ends with a screwdriver handle. Do Not Tap the Valve Body. If the unit is on the cooling cycle, raise the discharge pressure by restricting airflow through the outdoor coil. If the valve does not shift after the above attempts, cut the unit off, and wait until the discharge and suction pressure equalize, and repeat above steps. If the valve does not shift, replace it.

REVERSING VALVE TROUBLESHOOTING CHECKING REVERSING VALVE AND SOLENOID

Reversing valve used in heat pumps could potentially leak internally. Discharge gases can leak into the suction inside

the valve. Compound gages will give the same symptoms as bad compressor valves or broken scroll flanks. The temperature between true suction and the suction line after the valve should not be greater than 4 degrees. Note: The center tube is always the suction line and should be cold.

TROUBLESHOOTING THE REVERSING VALVE FOR ELECTRICAL FAILURE

1. Place unit into the cooling mode. Test for 24 volts at the solenoid. If there is no voltage present at coil, check the control voltage.
2. If voltage is present, loosen the nut on the top of the coil. Remove the coil, there should be slight resistance.
3. If the slight resistance is felt, remove the coil. As you remove the coil listen carefully, an audible click should be detected. The clicking is due to the movement of the pilot valve plunger. The absence of a clicking sound indicates the plunger is stuck.

TROUBLESHOOTING MECHANICAL FAILURES ON A REVERSING VALVE BY PRESSURE

1. Troubleshooting the reversing valve can be done by pressure and touch.
2. Raise the head pressure. In the cooling mode block the fan exhaust. Once head pressure has been raised, cycle between cooling and heating and see if the piston can be freed.

TROUBLESHOOTING MECHANICAL FAILURES ON A REVERSING VALVE BY TEMPERATURE

1. When operating properly the valve contains refrigerant gases at certain temperatures.
2. The discharge line should be the same temperature after the valves discharge line.
3. The true suction should be the same as the suction line after the valve. If there is a 4-degree difference, valve is leaking

When stuck in the mid-position, part of the discharge gas from the compressor is directed back to the suction side, resulting in excessively high suction pressure. An increase in the suction line temperature through the reversing valve can also be measured. Check operation of the valve by starting the system and switching the operation from COOLING to HEATING cycle.

If the valve fails to change its position, test the voltage (24V) at the valve coil terminals, while the system is on the COOLING cycle.

If voltage is registered at the coil, tap the valve body lightly while switching the system from HEATING to COOLING, etc. If this fails to cause the valve to switch positions, remove the coil connector cap and test the continuity of the reversing valve solenoid coil. If the coil does not test continuous - replace it. If the coil test continuous and 24 volts is present at the coil terminals, the valve is inoperative - replace it.

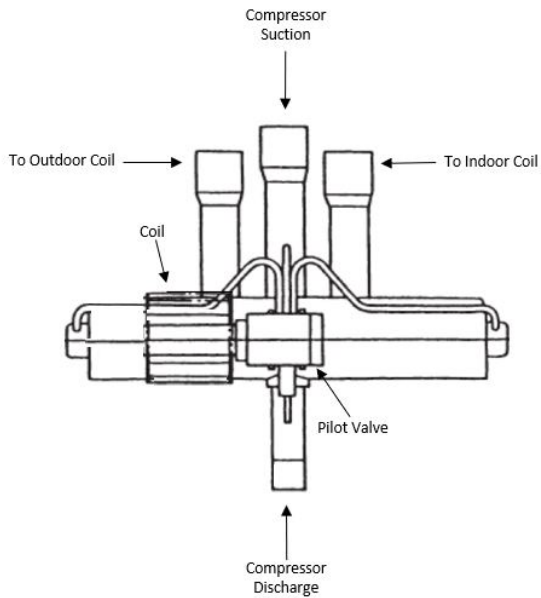

FIGURE 16: REVERSING VALVE

POOR “TERMINATING” SENSOR CONTACT

The unit’s defrost terminating sensor must make good thermal contact with the outdoor coil tubing. Poor contact may not terminate the unit’s defrost cycle quickly enough to prevent the unit from cutting out on high discharge pressure.

UNDERCHARGE

An undercharged heat pump on the heating cycle will cause low discharge pressure resulting in low suction pressure and frost accumulation on the outdoor coil.

TROUBLESHOOTING CHART



WARNING

HIGH VOLTAGE!

Disconnect ALL power before servicing or installing this unit. Multiple power sources may be present. Failure to do so may cause property damage, personal injury or death.



SYMPTOM	POSSIBLE CAUSE	REMEDY
High head - low suction	a. Restriction in liquid line or flowrator	a. Remove or replace with proper size flowrator.
High head - high or normal suction	a. Dirty condenser coil b. Overcharged c. Condenser fan not running	a. Clean coil b. Correct System charge c. Repair or Replace
Low head - high suction	a. Incorrect flowrator b. Defective compressor valves c. Flowrator not seating properly	a. Replace with correct flowrator b. Replace compressor c. Check for debris under flowrator or deformed flowrator. Remove debris or replace flowrator.
Unit will not run	a. Power off or loose electrical connection b. Thermostat out of calibration set too high c. Defective contactor d. Blown fuses or tripped breaker e. Transformer defective f. High or low pressure control open (Optional) g. Compressor overload contacts open	a. Check for unit voltage at contactor in unit b. Reset c. Check for 24 volts at contactor coil replace if contacts are open d. Replace fuse or reset breaker Check wiring - replace transformer f. Reset high pressure control or check unit charge High pressure control opens at 610 psig Low pressure control opens at 22 psig g. Replace compressor NOTE: Wait at least 2 hours for overload to reset
Condenser fan runs, compressor doesn't	a. Loose connection b. Compressor stuck, grounded or open winding open internal overload c. Low voltage connection d. Capacitor weak, open, or shorted	a. Check for unit voltage at compressor check & tighten all connections b. Wait at least 2 hours for overload to reset If still open, replace the compressor. c. At compressor terminals, voltage must be within 10 % of nameplate volts when unit is operating d. Check capacitor. If defective, replace.
Low suction - cool compressor Iced evaporator coil	a. Low indoor airflow	a. Increase speed of blower or reduce restriction - replace air filters
Compressor short cycles	a. Defective overload protector b. Unit cycling on low pressure control c. High pressure switch cuts out	a. Replace - check for correct voltage b. Check refrigerant charge and / or airflow c. Check airflow (Indoor & outdoor)
Registers sweat	a. Low airflow	a. Increase speed of blower or reduce restriction replace air filters
High suction pressure	a. Excessive load b. Defective compressor c. Reversing valve not seating properly.	a. Recheck load calculation b. Replace c. Replace
Insufficient cooling	a. Improperly sized unit b. Improper airflow c. Incorrect refrigerant charge. d. Incorrect voltage	a. Recalculate load b. Check - should be approximately 400 CFM per ton c. Charge per procedure attached to unit service panel d. At compressor terminals, voltage must be within 10% of nameplate volts when unit is operating
Evaporator coil freezing or frosting	a. Low airflow b. Low refrigerant charge c. Operating unit in cooling mode below 65°F outdoor temperature	a. Check - should be approximately 400 CFM per ton, dirty air filters, all duct outlets open b. Properly charge unit c. Install or check low ambient control, should be open below 65°F outdoor temperature

DP3CM[36-60]4* BLOWER PERFORMANCE DATA**

Horizontal Flow												
Model	Motor Tap	Compressor stage	Volts	E.S.P. (In. of H ₂ O)								
					0.1	0.2	0.3	0.4	0.5	0.6	0.7	0.8
DP3CM364***	T1	Single stage	230	CFM	1070	1030	980	935	870	775	720	665
				Watts	145	161	165	173	181	190	198	202
	T2/T3	Single stage	230	CFM	1468	1427	1385	1337	1293	1243	1189	1137
				Watts	288	296	304	310	318	325	333	340
	T4/T5	Single stage	230	CFM	1505	1465	1420	1385	1335	1300	1250	1205
				Watts	359	371	384	383	393	398	406	416
DP3CM484***	T1	Single stage	230	CFM	1355	1300	1250	1210	1155	1110	1045	965
				Watts	212	228	230	246	248	261	273	282
	T2/T3	Single stage	230	CFM	1844	1803	1763	1725	1682	1639	1593	1546
				Watts	438	447	457	468	477	484	491	498
	T4/T5	Single stage	230	CFM	1895	1855	1805	1770	1730	1685	1640	1600
				Watts	558	558	578	584	590	594	602	612
DP3CM604***	T1	Single stage	230	CFM	1360	1300	1260	1215	1175	1125	1058	1030
				Watts	213	221	233	244	255	264	273	293
	T2/T3	Single stage	230	CFM	1959	1920	1884	1847	1806	1768	1724	1680
				Watts	515	526	541	554	564	572	581	589
	T4/T5	Single stage	230	CFM	2000	1960	1925	1875	1835	1800	1760	1725
				Watts	642	651	660	651	672	683	691	699

DP3CM[36-60]4* BLOWER PERFORMANCE DATA**

Down flow												
Model	Motor Tap	Compressor stage	Volts	E.S.P. (In. of H ₂ O)								
					0.1	0.2	0.3	0.4	0.5	0.6	0.7	0.8
DP3CM364***	T1	Single stage	230	CFM	1006	968	921	879	818	729	677	625
				Watts	149	165	169	177	186	195	203	207
	T2/T3	Single stage	230	CFM	1380	1342	1302	1257	1215	1168	1118	1068
				Watts	295	304	312	318	326	333	341	348
	T4/T5	Single stage	230	CFM	1415	1377	1335	1302	1255	1222	1175	1133
				Watts	368	380	394	393	403	408	416	426
DP3CM484***	T1	Single stage	230	CFM	1274	1222	1175	1137	1086	1043	982	907
				Watts	217	234	236	252	254	268	280	289
	T2/T3	Single stage	230	CFM	1733	1695	1658	1622	1581	1541	1497	1453
				Watts	449	459	469	480	489	497	504	510
	T4/T5	Single stage	230	CFM	1781	1744	1697	1664	1626	1584	1542	1504
				Watts	572	572	592	599	605	609	617	627
DP3CM604***	T1	Single stage	230	CFM	1278	1222	1184	1142	1105	1058	1020	968
				Watts	218	227	239	250	261	271	280	300
	T2/T3	Single stage	230	CFM	1841	1805	1771	1736	1698	1661	1620	1579
				Watts	528	539	554	568	578	587	596	603
	T4/T5	Single stage	230	CFM	1880	1842	1810	1763	1725	1692	1654	1622
				Watts	658	667	677	667	689	700	708	716

NOTES:

- Data shown is dry coil. Wet coil pressure drop is approximately: 0.1" H₂O, for two-row indoor coil; 0.2" H₂O, for three-row coil; and 0.3" H₂O, for four-row indoor coil.
- Data shown does not include filter pressure drop, approx. 0.08" H₂O.
- Reduce airflow by 2% for 208-volt operation.

DP3HM[24-60]4* BLOWER PERFORMANCE DATA**

Horizontal Flow												
Model	Motor Tap	Compressor stage	Volts	E.S.P. (In. of H ₂ O)								
					0.1	0.2	0.3	0.4	0.5	0.6	0.7	0.8
DP3HM244***	T1	Single stage	230	CFM	847	792	728	638	-	-	-	-
				Watts	76	84	94	102	-	-	-	-
	T2/T3	Single stage	230	CFM	1114	1068	1017	964	901	829	751	667
				Watts	138	147	155	164	173	181	188	194
	T4/T5	Single stage	230	CFM	1371	1316	1281	1240	1186	1133	1072	1000
				Watts	235	243	252	261	266	275	284	293
DP3HM304***	T1	Single stage	230	CFM	877	821	758	674	596	531	481	-
				Watts	84	92	99	110	118	125	130	-
	T2/T3	Single stage	230	CFM	1347	1295	1243	1190	1134	1079	1010	938
				Watts	228	236	245	252	259	266	275	283
	T4/T5	Single stage	230	CFM	1463	1419	1376	1329	1282	1235	1183	1126
				Watts	284	294	302	309	317	325	333	340
DP3HM364***	T1	Single stage	230	CFM	850	795	726	640	559	-	-	-
				Watts	76	85	93	103	110	-	-	-
	T2/T3	Single stage	230	CFM	1438	1393	1354	1304	1258	1209	1154	1089
				Watts	271	280	291	296	305	312	320	329
	T4/T5	Single stage	230	CFM	1604	1560	1507	1468	1415	1364	1321	1276
				Watts	396	402	408	424	426	433	444	454
DP3HM424***	T1	Single stage	230	CFM	1003	937	887	837	773	699	631	574
				Watts	100	106	116	129	142	154	162	171
	T2/T3	Single stage	230	CFM	1534	1492	1453	1410	1372	1330	1287	1236
				Watts	257	269	279	290	301	311	322	334
	T4/T5	Single stage	230	CFM	1799	1754	1712	1672	1630	1582	1534	1482
				Watts	419	430	442	453	462	469	475	481
DP3HM484***	T1	Single stage	230	CFM	1177	1123	1077	1031	972	-	-	-
				Watts	142	151	162	173	185	-	-	-
	T2/T3	Single stage	230	CFM	1825	1785	1748	1713	1674	1610	1609	1544
				Watts	439	448	460	470	480	488	489	498
	T4/T5	Single stage	230	CFM	1984	1947	1975	1864	1823	1781	1741	1694
				Watts	567	578	590	596	603	610	618	623
DP3HM604***	T1	Low stage	230	CFM	1488	1448	1410	1371	1336	1293	1254	1204
				Watts	270	279	290	305	318	330	343	356
	T2/T3	High stage	230	CFM	2029	1991	1956	1920	1876	1829	1801	1766
				Watts	616	622	631	638	648	656	671	682
	T4/T5	High stage	230	CFM	2199	2161	2126	2090	2056	2018	1982	1949
				Watts	801	809	817	828	838	851	858	873

NOTES:

- Data shown is dry coil. Wet coil pressure drop is approximately: 0.1" H₂O, for two-row indoor coil; 0.2" H₂O, for three-row coil; and 0.3" H₂O, for four-row indoor coil.
- Data shown does not include filter pressure drop, approx. 0.08" H₂O.
- Reduce airflow by 2% for 208-volt operation.

DP3HM[24-60]4*** BLOWER PERFORMANCE DATA

Down flow												
Model	Motor Tap	Compressor stage	Volts	E.S.P. (In. of H ₂ O)								
					0.1	0.2	0.3	0.4	0.5	0.6	0.7	0.8
DP3HM244***	T1	Single stage	230	CFM	828	767	680	574	-	-	-	-
				Watts	75	85	95	104	-	-	-	-
	T2/T3	Single stage	230	CFM	1085	1019	960	888	813	713	657	601
				Watts	136	144	152	162	173	180	185	191
	T4/T5	Single stage	230	CFM	1355	1300	1254	1201	1147	1084	1007	899
				Watts	244	253	260	268	276	285	294	303
DP3HM304***	T1	Single stage	230	CFM	859	797	719	619	552	497	437	-
				Watts	83	92	101	111	118	122	127	-
	T2/T3	Single stage	230	CFM	1302	1257	1198	1148	1089	1023	936	844
				Watts	220	228	238	246	254	263	273	282
	T4/T5	Single stage	230	CFM	1439	1396	1341	1294	1246	1185	1119	1047
				Watts	288	297	305	313	322	330	339	347
DP3HM364***	T1	Single stage	230	CFM	825	762	686	577	523	-	-	-
				Watts	77	87	97	105	111	-	-	-
	T2/T3	Single stage	230	CFM	1436	1389	1338	1289	1241	1186	1122	1053
				Watts	281	290	298	307	315	325	334	343
	T4/T5	Single stage	230	CFM	1595	1555	1506	1462	1415	1370	1319	1260
				Watts	382	391	399	408	418	426	435	444
DP3HM424***	T1	Single stage	230	CFM	981	918	850	761	687	613	553	488
				Watts	100	113	126	138	153	161	171	179
	T2/T3	Single stage	230	CFM	1490	1433	1371	1318	1260	1197	1121	1023
				Watts	258	273	285	297	309	323	335	347
	T4/T5	Single stage	230	CFM	1786	1728	1678	1629	1577	1517	1453	1385
				Watts	419	432	445	457	468	474	482	490
DP3HM484***	T1	Single stage	230	CFM	1168	1101	1045	979	913	-	-	-
				Watts	144	155	168	182	197	-	-	-
	T2/T3	Single stage	230	CFM	1829	1771	1720	1670	1613	1556	1493	1426
				Watts	440	452	465	478	486	494	501	510
	T4/T5	Single stage	230	CFM	2004	1949	1892	1837	1782	1728	1674	1616
				Watts	564	577	587	594	603	612	620	628
DP3HM604***	T1	Low stage	230	CFM	1399	1361	1326	1289	1256	1215	1179	1132
				Watts	277	286	298	312	326	338	351	365
	T2/T3	High stage	230	CFM	1907	1872	1839	1804	1763	1719	1692	1660
				Watts	632	638	646	654	664	672	688	699
	T4/T5	High stage	230	CFM	2067	2031	1999	1964	1932	1897	1863	1832
				Watts	821	829	838	849	859	872	880	895

NOTES:

- Data shown is dry coil. Wet coil pressure drop is approximately: 0.1" H₂O, for two-row indoor coil; 0.2" H₂O, for three-row coil; and 0.3" H₂O, for four-row indoor coil.
- Data shown does not include filter pressure drop, approx. 0.08" H₂O.
- Reduce airflow by 2% for 208-volt operation.

DIMENSIONS

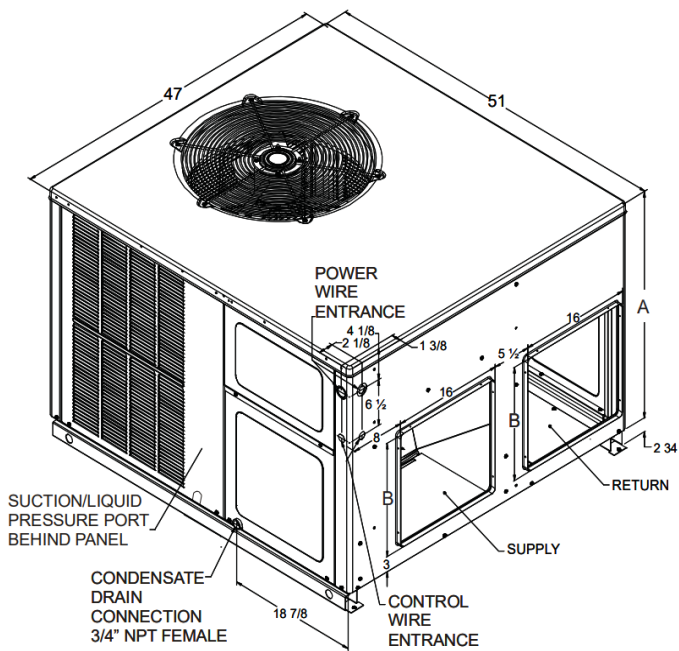

DIMENSION (INCHES)	MEDIUM	LARGE
A	32	40
B	16	18

- MEDIUM CHASSIS**

 - DP3CM364*
 - DP3HM244*
 - DP3HM304*
 - DP3HM364*

LARGE CHASSIS

 - DP3CM484*
 - DP3CM604*
 - DP3HM424*
 - DP3HM484*
 - DP3HM604*

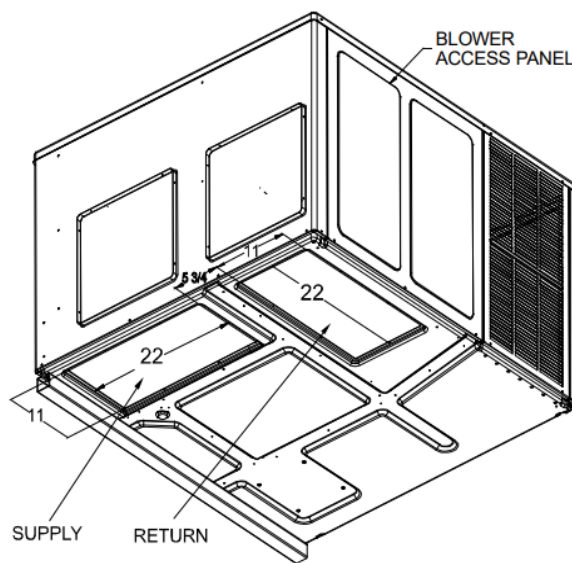

MINIMUM CLEARANCES

NOTE: Roof overhang
Should be no more than 48"

PACKAGE UNITS - HEAT PUMP AND AC UNITS

HOMEOWNER'S ROUTINE MAINTENANCE RECOMMENDATIONS

WE STRONGLY RECOMMEND A BI-ANNUAL MAINTENANCE CHECKUP BE PERFORMED BY A QUALIFIED SERVICE AGENCY BEFORE THE HEATING AND COOLING SEASONS BEGIN.



WARNING

HIGH VOLTAGE!

DISCONNECT ALL POWER BEFORE SERVICING OR INSTALLING THIS UNIT. MULTIPLE POWER SOURCES MAY BE PRESENT. FAILURE TO DO SO MAY CAUSE PROPERTY DAMAGE, PERSONAL INJURY OR DEATH.



REPLACE OR CLEAN FILTER

IMPORTANT NOTE: Never operate unit without a filter installed as dust and lint will build up on internal parts resulting in loss of efficiency, equipment damage and possible fire.

A return air filter is not supplied with this unit; however, there must be a means of filtering the return air. An indoor air filter must be used with your comfort system. A properly maintained filter will keep the indoor coil of your comfort system clean. A dirty coil could cause poor operation and/or severe equipment damage. The installer of your unit can tell you where your filter(s) are and how to clean or replace them.

Check your return filter(s) at least once every two months. When they are dirty, replace or clean as required.

Disposable type filters should be replaced. Reusable type filters may be cleaned. **NOTE:** Reusable type filters should be washed with warm water, dried completely and sprayed with an adhesive according to the manufacturers recommendations.

You may want to ask your dealer about high efficiency filters. High efficiency filters are available in both electronic and non-electronic types. These filters can do a better job of catching small airborne particles.

Improper filter maintenance is the most common cause of inadequate heating or cooling performance. Filters should be cleaned (permanent) or replaced (disposable) every two months or as re-quired. When replacing a filter, it must be replaced with a filter of the same type and size and always make certain the air flow arrows on the filter point in the proper direction.

CONDENSER AND EVAPORATOR MOTORS

The bearings on the air circulating blower motor and condenser motor are permanently lubricated and require no further lubrication.

COMPRESSOR

The compressor motor is hermetically sealed and does not require additional oiling.

ALUMINUM INDOOR COIL CLEANING (QUALIFIED SERVICER ONLY)

This unit is equipped with an aluminum tube evaporator coil. The safest way to clean the evaporator coil is to simply flush the coil with water. This cleaning practice remains as the recommended cleaning method for both copper tube and aluminum tube residential cooling coils.

An alternate cleaning method is to use one of the products listed in the technical publication TP-109 (shipped in the literature bag with the unit) to clean the coils. The cleaners listed are the only agents deemed safe and approved for use to clean round tube aluminum coils. TP-109 is available on the web site in Partner Link > Service Toolkit. **NOTE:** Ensure coils are rinsed well after use of any chemical cleaners.

ANNUAL INSPECTION (QUALIFIED SERVICER ONLY)

Your package unit should be inspected by a qualified installer, or service agency at least twice every year. This check should be performed before the heating and cooling seasons begin. This will ensure that the system is performing properly and safely. Repair as necessary.

- Check physical support of the unit. Ensure it is sound without any sagging, cracks, or gaps, around the base.
- Check for obvious signs of deterioration of the unit.
- Check both condenser and evaporator coil to make sure each are clean.
- Return Air Connection. Check for physical soundness and ensure that the connection is firmly sealed to the package unit casing.
- Wiring. Check wires for damage. Check electrical connections for tightness and/or corrosion.
- Filters. Check that filters are clean and in the proper placement in the unit or duct system.
- Louvers. Inspect air inlet louvers inside the heat exchanger compartments. Ensure the area is clean and free of dirt and debris.

BEFORE CALLING YOUR SERVICER

- Check the thermostat to confirm that it is properly set.
- Check the disconnect switch near the unit to confirm that it is closed.
- Check the electrical panel for tripped circuit breakers or failed fuses . Reset the circuit breakers or replace fuses as necessary.
- Check for blockage of the indoor air inlets and outlets. Confirm that they are open and have not been blocked by objects (rugs, curtains or furniture).
- Check for obstructions on the unit. Confirm that it has not been covered on the sides or the top. Remove any obstruction that can be safely removed. If the unit is covered with dirt or debris, call a qualified servicer to clean it.
- Check the filter. If it is dirty, clean or replace it.

START-UP CHECKLIST

Residential Package - (Indoor Section)			
	Model Number		
	Serial Number		
ELECTRICAL			
Line Voltage (Measure L1 and L2 Voltage)	L1 - L2		
Secondary Voltage (Measure Transformer Output Voltage)	R - C		
Blower Amps			
Heat Strip 1 - Amps			
Heat Strip 2 - Amps			
BLOWER EXTERNAL STATIC PRESSURE			
Return Air Static Pressure			
Supply Air Static Pressure			
Total External Static Pressure (Ignoring +/- from the reading above, add total here)			
TEMPERATURES			
Return Air Temperature (Dry bulb / Wet bulb)			
Cooling Supply Air Temperature (Dry bulb / Wet bulb)			
Heating Supply Air Temperature			
Temperature Rise			
Delta T (Difference between Supply and Return Temperatures)			
GAS PRESSURES			
Gas Inlet Pressure			
Gas Manifold Pressure (Low Fire)			
Gas Manifold Pressure (High Fire)			
Gas Type (NG) = Natural Gas / (LP) = Liquid Propane			
Residential Package - (Outdoor Section)			
ELECTRICAL			
Supply Voltage (Measure L1 and L2 Voltage)	L1 - L2		
Compressor Amps			
Condenser Fan Amps			
PRESSURES / TEMPERATURES			
Suction Circuit (Pressure / Suction Line Temperature)	PSIG		
Liquid Circuit (Pressure / Liquid Temperature)	PSIG		
Outdoor Air Temperature (Dry bulb / Wet bulb)			
SUPERHEAT / SUBCOOLING			
	SH		
Additional Checks			
Check wire routings for any rubbing			
Check product for proper draining			
Check for kinked pressure switch tubing.			
Check flue elbow for alignment and clamp tightness.			
Check screw tightness on blower wheel.			
Check factory wiring and wire connections.			
Check screw tightness on Outdoor Motor and Blade			
Check product for proper clearances as noted by installation instructions			
$^{\circ}\text{F to }^{\circ}\text{C formula: } (^{\circ}\text{F} - 32) \text{ divided by } 1.8 = ^{\circ}\text{C}$ $^{\circ}\text{C to }^{\circ}\text{F formula: } (^{\circ}\text{C multiplied by } 1.8) + 32 = ^{\circ}\text{F}$			

CUSTOMER FEEDBACK

Daikin Comfort Technologies is very interested in all product comments.

Please fill out the feedback form on the following link:

<https://daikincomfort.com/contact-us>

You can also scan the QR code on the right to be directed to the feedback page.



PRODUCT REGISTRATION

Thank you for your recent purchase. Though not required to get the protection of the standard warranty, registering your product is a relatively short process, and entitles you to additional warranty protection, except that failure by California and Quebec residents to register their product does not diminish their warranty rights. The duration of warranty coverages in Texas and Florida differs in some cases.

For Product Registration, please register by following this link:

<https://daikincomfort.com/owner-support/product-registration>

You can also scan the QR code on the right to be directed to the Product Registration page.



Our continuing commitment to quality products may mean a change in specifications without notice.

©2022-2023 **DAIKIN COMFORT TECHNOLOGIES MANUFACTURING, L.P.**

19001 Kermier Rd., Waller, TX 77484

www.daikincomfort.com