

AHKD SERIES

ELECTRIC RESISTANCE HEAT KITS

INSTALLATION INSTRUCTIONS

©2013-2019, 2022 **DAIKIN COMFORT TECHNOLOGIES MANUFACTURING, L.P.**

19001 Kermier Rd., Waller, TX 77484

www.daikincomfort.com

P/N: IOD-7031B Date: June 2022



WARNING

ONLY PERSONNEL THAT HAVE BEEN TRAINED TO INSTALL, ADJUST, SERVICE, MAINTENANCE OR REPAIR (HEREINAFTER, "SERVICE") THE EQUIPMENT SPECIFIED IN THIS MANUAL SHOULD SERVICE THE EQUIPMENT. THE MANUFACTURER WILL NOT BE RESPONSIBLE FOR ANY INJURY OR PROPERTY DAMAGE ARISING FROM IMPROPER SERVICE OR SERVICE PROCEDURES. IF YOU SERVICE THIS UNIT, YOU ASSUME RESPONSIBILITY FOR ANY INJURY OR PROPERTY DAMAGE WHICH MAY RESULT. IN ADDITION, IN JURISDICTIONS THAT REQUIRE ONE OR MORE LICENSES TO SERVICE THE EQUIPMENT SPECIFIED IN THIS MANUAL, ONLY LICENSED PERSONNEL SHOULD SERVICE THE EQUIPMENT. IMPROPER INSTALLATION, ADJUSTMENT, SERVICING, MAINTENANCE OR REPAIR OF THE EQUIPMENT SPECIFIED IN THIS MANUAL, OR ATTEMPTING TO INSTALL, ADJUST, SERVICE OR REPAIR THE EQUIPMENT SPECIFIED IN THIS MANUAL WITHOUT PROPER TRAINING MAY RESULT IN PRODUCT DAMAGE, PROPERTY DAMAGE, PERSONAL INJURY OR DEATH.



WARNING

DO NOT BYPASS SAFETY DEVICES.

INTRODUCTION

PRODUCT DESCRIPTION

The AHKD series of electric heat kits is an accessory designed for installation with the Daikin DAX0904 or DAX1204 Airhandler **ONLY. INSTALLATIONS WITH OTHER AIRHANDLERS IS NOT PERMITTED.** For installation guidelines of the DAX0904 or DAX1204, refer to the instructions which accompany the air handler, IOD-1056 (Installation & Operating Instructions).

The AHKD provides supplemental electric heat for the DAX0904/1204. The assembly is to be installed directly to the outlet of the DAX0904/1204 and is not to be used as an independent duct heater.

The AHKD20 and AHKD30 heat kits have two stages. A two stage room thermostat determines the staging by room temperature.

The heat kit's control panel is "self contained" and is equipped with all of the safety circuit/limits required per UL1995. The heat kit employs a terminal block for installation of the high voltage wires used by both the heat kit and the airhandler (single point wiring).

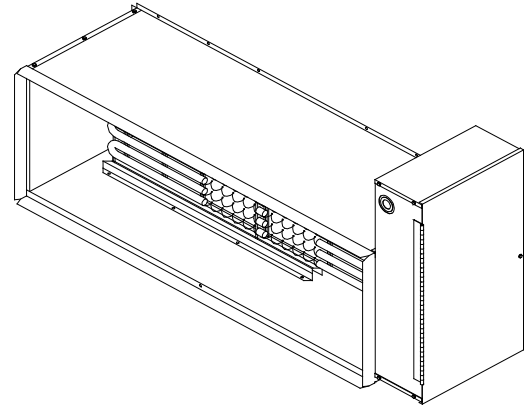

CHECKING PRODUCT RECEIVED

Upon receiving the unit, inspect it for damage from shipment. Claims for damage, either shipping or concealed, should be filed immediately with the shipping company. Do not install this accessory if it is determined that the integrity or safety has been compromised by freight damage.

Check the unit model number, specifications, and electrical characteristics to determine if they are correct. In the event an incorrect unit is shipped, it must be returned to the supplier and must NOT be installed. The manufacturer assumes no responsibility for installation of incorrectly shipped units.

REPLACEMENT PARTS

ORDERING PARTS

When reporting shortages or damages, or ordering repair parts, give the complete unit model and serial numbers of the heater kit as stamped on the product.

Replacement parts for this product are available through your contractor or local distributor. For the location of your nearest distributor, consult the white business pages, the yellow page section of the local telephone book or contact:







EQUIPMENT SUPPORT
DAIKIN COMFORT TECHNOLOGIES
MANUFACTURING, L.P.
19001 KERMIER ROAD
WALLER, TEXAS 77484
855-770-5678



IMPORTANT SAFETY INSTRUCTIONS

RECOGNIZE SAFETY SYMBOLS, WORDS, AND LABELS

The following symbols and labels are used throughout this manual to indicate immediate or potential hazards. It is the owner's responsibility to read and comply with all safety information and instructions accompanying these symbols. Failure to heed safety information increases the risk of property damage, product damage, personal injury or death.

	WARNING
<p>HIGH VOLTAGE DISCONNECT ALL POWER BEFORE SERVICING OR INSTALLING THIS UNIT. MULTIPLE POWER SOURCES MAY BE PRESENT. FAILURE TO DO SO MAY CAUSE PROPERTY DAMAGE, PERSONAL INJURY OR DEATH.</p>	
	WARNING
<p>ONLY INDIVIDUALS MEETING THE REQUIREMENTS OF AN "ENTRY LEVEL TECHNICIAN," AT A MINIMUM, AS SPECIFIED BY THE AIR CONDITIONING, HEATING, AND REFRIGERATION INSTITUTE (AHRI) MAY USE THIS INFORMATION. ATTEMPTING TO INSTALL OR REPAIR THIS UNIT WITHOUT SUCH BACKGROUND MAY RESULT IN PRODUCT DAMAGE, PERSONAL INJURY OR DEATH.</p>	
	WARNING
<p>TO AVOID PROPERTY DAMAGE, PERSONAL INJURY OR DEATH DUE TO ELECTRICAL SHOCK, THIS UNIT MUST HAVE AN <u>UNINTERRUPTED, UNBROKEN</u> ELECTRICAL GROUND. THE ELECTRICAL GROUND CIRCUIT MAY CONSIST OF AN APPROPRIATELY SIZED ELECTRICAL WIRE CONNECTING THE GROUND LUG IN THE UNIT CONTROL BOX TO THE BUILDING ELECTRICAL SERVICE PANEL. OTHER METHODS OF GROUNDING ARE PERMITTED IF PERFORMED IN ACCORDANCE WITH THE NATIONAL ELECTRIC CODE (NEC) / AMERICAN NATIONAL STANDARDS INSTITUTE (ANSI) / NATIONAL FIRE PROTECTION ASSOCIATION (NFPA) 70 AND LOCAL/STATE CODES. IN CANADA, ELECTRICAL GROUNDINGS IS TO BE IN ACCORDANCE WITH THE CANADIAN ELECTRICAL CODE (CSA) C22.1.</p>	
	CAUTION
<p>WHEN INSTALLING OR SERVICING THIS EQUIPMENT, SAFETY CLOTHING, INCLUDING HAND AND EYE PROTECTION, IS STRONGLY RECOMMENDED. IF INSTALLING IN AN AREA THAT HAS SPECIAL SAFETY REQUIREMENTS (HARD HATS, ETC.), OBSERVE THESE REQUIREMENTS.</p>	
	WARNING
<p>DO NOT CONNECT TO OR USE ANY DEVICE THAT IS NOT DESIGN-CERTIFIED BY THE MANUFACTURER FOR USE WITH THIS UNIT. SERIOUS PROPERTY DAMAGE, PERSONAL INJURY, REDUCED UNIT PERFORMANCE AND/OR HAZARDOUS CONDITIONS MAY RESULT FROM THE USE OF SUCH NON-APPROVED DEVICES.</p>	

CODES & REGULATIONS

This product is designed and manufactured to comply with national codes. Installation in accordance with such codes and/or prevailing local codes/regulations is the responsibility of the installer. The manufacturer assumes no responsibility for equipment installed in violation of any codes or regulations.

PRE-INSTALLATION INSTRUCTIONS

Carefully read all instructions for the installation prior to installing product. Make sure each step or procedure is understood and any special considerations are taken into account before starting installation. Assemble all tools, hardware and supplies needed to complete the installation. Some items may need to be purchased locally. Make sure everything needed to install the product is on hand before starting.

MODEL IDENTIFICATION

Refer to this manual in combination with the instructions provided with the air handler for the correct installation procedure.

The electrical characteristics of the air handler, the electric heat kit and the building power supply must agree.

Use the following table and the product's Series and Rating Plate to determine the heating kW and electrical characteristics.

AHKD MODEL NUMBER	NOMINAL KW	ELECTRICAL CHARACTERISTICS	STAGES
AHKD15-3A	15	208-240/3/60	1
AHKD15-4A	15	480/3/60	1
AHKD20-3A	20	208-240/3/60	2
AHKD20-4A	20	480/3/60	2
AHKD30-3A	30	208-240/3/60	2
AHKD30-4A	30	480/3/60	2

TABLE 1

For all supply voltages, use the correction factors in Tables 2 & 3, multiplied by kW and (or) temperature rise to have corrected results.

KW Correction Factors (-3A Models)

Supply Voltage	240	230	220	210	208
Correction Factor	1.0	0.92	0.84	0.77	0.75

TABLE 2

KW Correction Factors (-4A Models)

Supply Voltage	480	460	440	415	380
Correction Factor	1.0	0.92	0.84	0.75	0.63

TABLE 3

TEMPERATURE RISE

The heating mode temperature rise is dependent upon the system airflow, the supply voltage, and the heat kit size (kW) selected. Use Tables 4 & 5 to determine the temperature rise (°F):

DAX0904 Temperature Rise Table (Degrees °F)

DAX0904 Temperature Rise Table (°F) - 7.5Ton				
KW	CFM	208	240	480
15	2800	12	16	16
15	2900	12	16	16
15	3000	11	15	15
15	3100	11	15	15
15	3200	10	14	14
20	2800	16	22	22
20	2900	16	21	21
20	3000	16	21	21
20	3100	16	20	20
20	3200	15	20	20
30	2800	24	32	32
30	2900	23	31	31
30	3000	23	30	30
30	3100	21	29	29
30	3200	21	29	29

TABLE 4

DAX1204 Temperature Rise Table (Degrees °F)

DAX1204 Temperature Rise Table (°F) - 10Ton				
KW	CFM	208	240	480
15	3800	9	12	12
15	3900	9	12	12
15	4000	9	12	12
15	4100	9	12	12
15	4200	8	11	11
20	3800	12	17	17
20	3900	12	16	16
20	4000	12	16	16
20	4100	12	15	15
20	4200	11	15	15
30	3800	19	25	25
30	3900	18	24	24
30	4000	18	24	24
30	4100	17	23	23
30	4200	17	23	23

TABLE 5

NOTE: TABLE 4 AND 5 IS CALCULATED WITH BOTH STAGES OF ELECTRIC HEAT ENGAGED (2 STAGE HEAT SYSTEMS).

FOR SYSTEMS USING STAGED ELECTRIC HEAT, DIVIDE THE TEMPERATURE RISE FROM THE TABLE BY 2 FOR 1ST STAGE OPERATION.

ELECTRICAL SUPPLY WIRE AND MOP



WARNING

HIGH VOLTAGE

DISCONNECT ALL POWER BEFORE SERVICING OR INSTALLING THIS UNIT. MULTIPLE POWER SOURCES MAY BE PRESENT. FAILURE TO DO SO MAY CAUSE PROPERTY DAMAGE, PERSONAL INJURY OR DEATH.



WARNING

TO AVOID THE RISK OF FIRE OR EQUIPMENT DAMAGE, USE COPPER CONDUCTORS ONLY.



WARNING

TO AVOID PROPERTY DAMAGE, PERSONAL INJURY OR DEATH DUE TO ELECTRICAL SHOCK, THIS UNIT MUST HAVE AN UNINTERRUPTED, UNBROKEN ELECTRICAL GROUND. THE ELECTRICAL GROUND CIRCUIT MAY CONSIST OF AN APPROPRIATELY SIZED ELECTRICAL WIRE CONNECTING THE GROUND LUG IN THE UNIT CONTROL BOX TO THE BUILDING ELECTRICAL SERVICE PANEL. OTHER METHODS OF GROUNDING ARE PERMITTED IF PERFORMED IN ACCORDANCE WITH THE NATIONAL ELECTRIC CODE (NEC) / AMERICAN NATIONAL STANDARDS INSTITUTE (ANSI) / NATIONAL FIRE PROTECTION ASSOCIATION (NFPA) 70 AND LOCAL/STATE CODES. IN CANADA, ELECTRICAL GROUNDINGS IS TO BE IN ACCORDANCE WITH THE CANADIAN ELECTRICAL CODE (CSA) C22.1.



WARNING

INSPECTION OF THE BUILDING ELECTRICAL SERVICE. THIS UNIT IS DESIGNED FOR 3-PHASE OPERATION. **DO NOT OPERATE ON A SINGLE PHASE POWER SUPPLY. SEE THE "WARNING" ABOVE.** MEASURE THE POWER SUPPLY TO THE UNIT. THE SUPPLY VOLTAGE MUST BE IN AGREEMENT WITH THE UNIT NAMEPLATE POWER REQUIREMENTS AND WITHIN THE RANGE SHOWN IN TABLE 6.

Building Electrical Service Inspection

This unit is designed for 3-phase operation. **DO NOT OPERATE ON A SINGLE PHASE POWER SUPPLY. SEE THE PRECEDING WARNING.** Measure the power supply to the unit. The supply voltage MUST be in agreement with the unit nameplate power requirements and within the range shown in Table 6.

Nominal	Minimum Supply Voltage	Maximum Supply Voltage
208 - 230	187	253
460	414	506

TABLE 6

Voltage Balance: The supply voltage shall be unbalance (phase to phase) within 2%. To calculate the percentage of voltage unbalance use the following formula:

$$\text{Percentage Voltage Unbalance} = 100 \times \frac{\text{Max Voltage Deviation From Average}}{\text{Average Voltage}}$$

Example:
 $L1 - L2 = 220 \text{ V}$
 $L2 - L3 = 216 \text{ V}$
 $L1 - L3 = 213 \text{ V}$

$$\begin{aligned} \text{Avg. Voltage:} &= (220+216+213) / 3 \\ &= 649 / 3 \\ &= 216 \end{aligned}$$

$$\text{Max. Deviation from Avg.} = 220 - 216 = 4$$

$$\begin{aligned} \% \text{ Voltage Unbalance} &= 100 \times (4 / 216) \\ &= 400 / 216 \\ &= 1.8\% \end{aligned}$$

Determine Wire Size: The selection of the appropriate supply wire size is important to the operation of the equipment. When selecting the wire size, the following are important elements of the decision:

- The wire size is adequately sized to carry the Minimum Circuit Ampacity (MCA). Refer to the NEC (USA) or CSA (Canada) for wire sizing. The unit MCA for the air handler and the optional electric heat kit can be found on the equipment S&R plate and the following table.

AIRHANDLER	VOLTAGE	HEAT KIT	MCA
DAX0904 and DAX1204	208 - 230	None	15.5 / 15.5
		AHKD15-3A	56.3 / 62.4
		AHKD20-3A	69.4 / 77.4
		AHKD30-3A	95.4 / 108
	460	None	5.2
		AHKD15-4A	28.3
		AHKD20-4A	35.8
		AHKD30-4A	50.9

TABLE 7

MAXIMUM ALLOWABLE LENGTH IN FEET TO LIMIT VOLTAGE DROP TO 2%

Wire Size (AWG)	Minimum Circuit Ampacity (MCA)							
	10	15	20	25	30	35	40	45
14	77	51	38	NR	NR	NR	NR	NR
12	122	81	61	49	NR	NR	NR	NR
10	193	129	97	77	64	55	NR	NR
8	307	205	154	123	103	88	77	68
6	489	326	244	195	163	140	122	109

TABLE 8

MAXIMUM OVERCORRECT PROTECTION (MOP)

Every installation must include an NEC (USA) or CEC (Canada) approved overcorrect protection device. Also, check with local or state codes for any special regional requirements.

Protection can be in the form of fusing or HACR style circuit breakers. The Series and Rating Plate can be used as a guide for selecting the MAXIMUM overcurrent device or reference the following table.

NOTE: FUSES OR CIRCUIT BREAKERS ARE TO BE SIZED LARGER THAN THE EQUIPMENT MCA BUT NOT TO EXCEED THE MOP.

AIRHANDLER	VOLTAGE	HEAT KIT	MOP
DAX0904 and DAX1204	208 - 230	None	20 / 20
		AHKD15-3A	60 / 70
		AHKD20-3A	70 / 80
		AHKD30-3A	100 / 110
	460	None	15
		AHKD15-4A	30
		AHKD20-4A	40
		AHKD30-4A	60

TABLE 9

- The wire size is appropriately sized to allow for no more than a 2% voltage drop from the building breaker/fuse panel to the unit.
- Refer to the latest edition of the National Electric Code or in Canada the Canadian Electric Code when determining the correct wire size.
- Table 8 shows the current carrying capabilities for copper conductors rated at 75°C with a 2% voltage drop. Use Table 8 to determine the voltage drop per foot of various conductors.

ATTACHING THE HEAT KIT

1. Secure the high voltage and low voltage conduits to the heat kit electrical panel using the supplied plastic bushing nuts as shown in Figure 1.

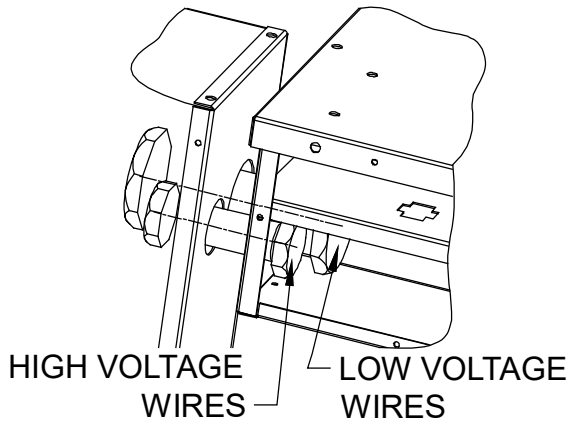

FIGURE 1

2. The heat kit attaches directly to the top panel (when viewed in the upflow position) of the air handler. Do not screw the heat kit into the duct flanges. Position the heat kit onto the air handler at the air discharge end with the control box orientated toward the airhandler front. See Figure 2.

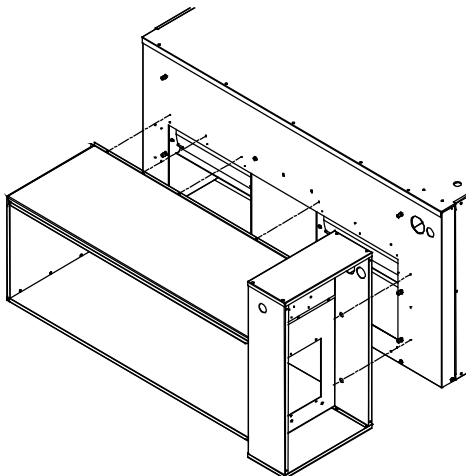

FIGURE 2

3. Route the two electrical conduits (attached in step 1) through the panel on the airhandler. Secure the conduits to the air handler panel with the supplied plastic bushing nuts. See Figure 3.
4. Using the supplied 1/2" long #10 screws, attach the heat kit to the air handler outlet panel. **NOTE:** Open the heat kit electrical panel door to obtain access to the three screws on that side.
5. Follow the "Electrical Connections" section of this manual for wiring details.

ELECTRICAL CONNECTIONS



WARNING

TO AVOID THE RISK OF FIRE OR EQUIPMENT DAMAGE, USE COPPER CONDUCTORS ONLY.

Supply Voltage

A single point supply voltage termination is provided in the heat kit control box. The wire is to be sized in accordance with the Electrical Wire and MOP section of this manual. See Figure 4.

The supply wire is to be routed through conduit from the service disconnect box to the heater kit. The heat kit is equipped with a knockout suitable for 1/2" or 3/4" conduit, dependent on the kW. The supply voltage is to be installed on the terminal block located in the heater kit control box.

The heater kit is factory equipped with the supply and low voltage wires for the air handler. The low voltage connection from the heater kit is provided through a multi-pin plug which connects to a mating plug in the air handler. The high voltage connections are to be made at the air handler contactor. These wires are to be routed through the pipe nipples supplied with the heater kit as shown in the following illustration.

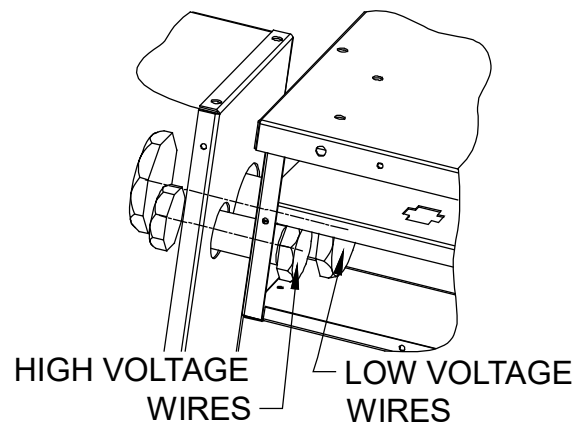

FIGURE 3

Route the air handler supply voltage and ground conductors through the 1/2" conduit that connects the heat kit to the airhandler. Attach the supply voltage wires to the air handler contactor and the equipment ground to the air handler ground lug. To assist with possible troubleshooting, follow the wire color conventions indicated on the wiring diagram.

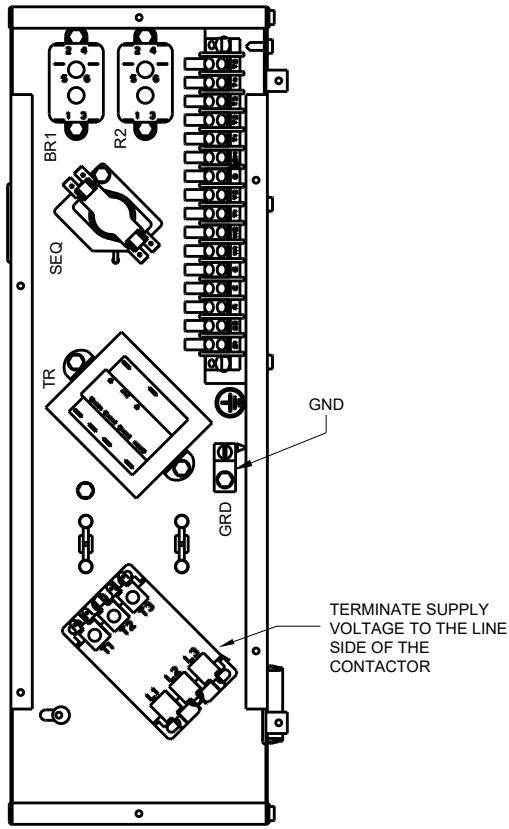

FIGURE 4

Low Voltage Connections

The low voltage connection from the air handler to the heat kit is provided through a multi-pin plug that connects to a mating plug in the airhandler. Route the heat kit low voltage harness through the 1 1/2" conduit to the airhandler control box and plug into the airhandler low voltage harness. **NOTE:** Low voltage from the room thermostat is terminated in the airhandler control box. Wiring options for the thermostat wiring are shown in the air handler installation manual. See Figures 5 and 6.

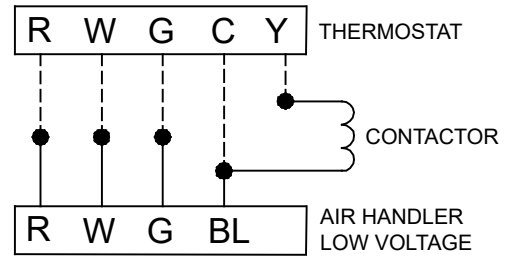

FIGURE 5

Single Stage Heat - Single Stage Cooling where

- R - Red
- W - White
- G - Green
- BL - Blue

NOTE: BROWN WIRE IS NOT USED AND IS TO BE TAPED.

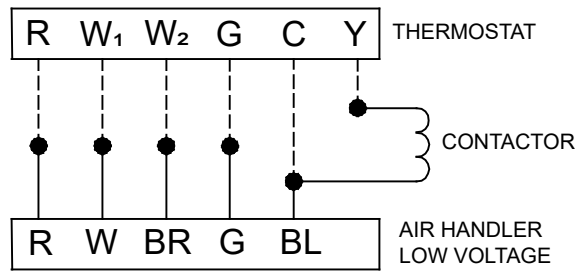

FIGURE 6

Two-Stage Heat - Single Stage Cooling where

- R - Red
- W - White
- BR - Brown
- G - Green
- BL - Blue

WIRING DIAGRAM

WARNING

HIGH VOLTAGE!
DISCONNECT ALL POWER BEFORE SERVICING OR INSTALLING THIS UNIT.
MULTIPLE POWER SOURCES MAY BE PRESENT. FAILURE TO DO SO MAY
CAUSE PROPERTY DAMAGE, PERSONAL INJURY OR DEATH.

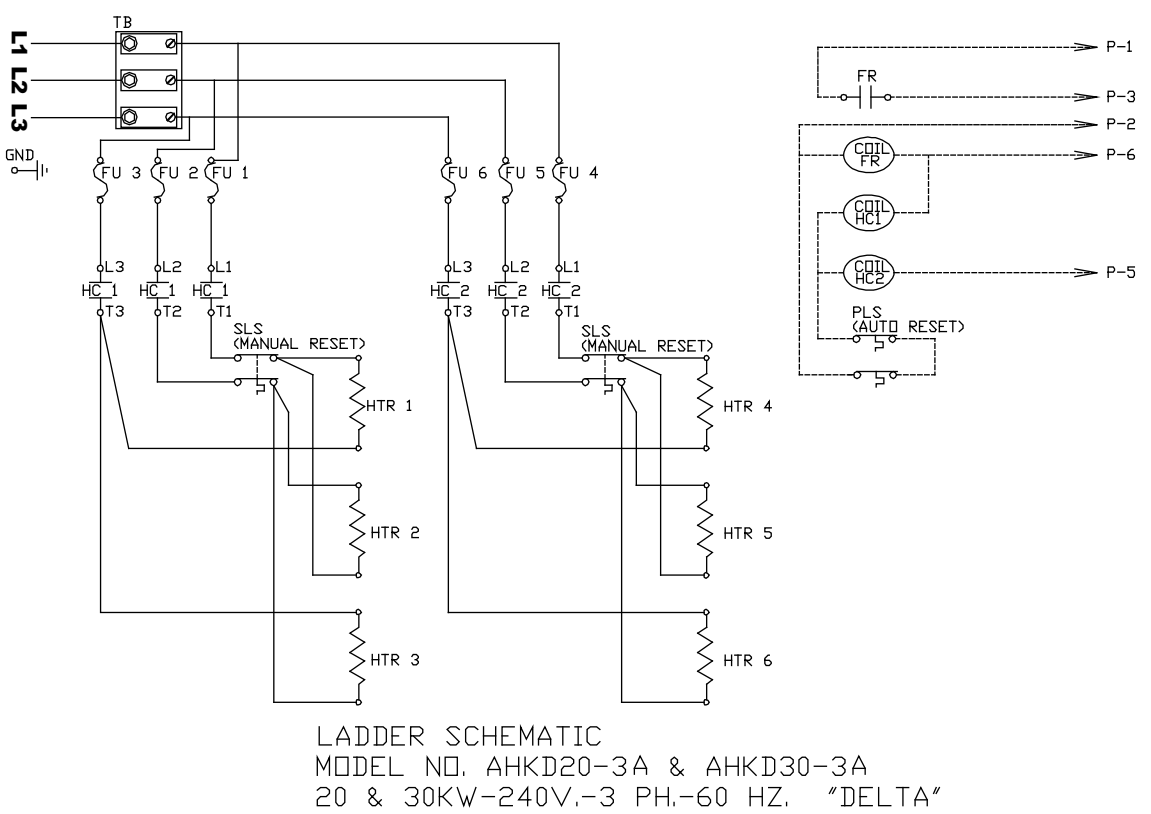
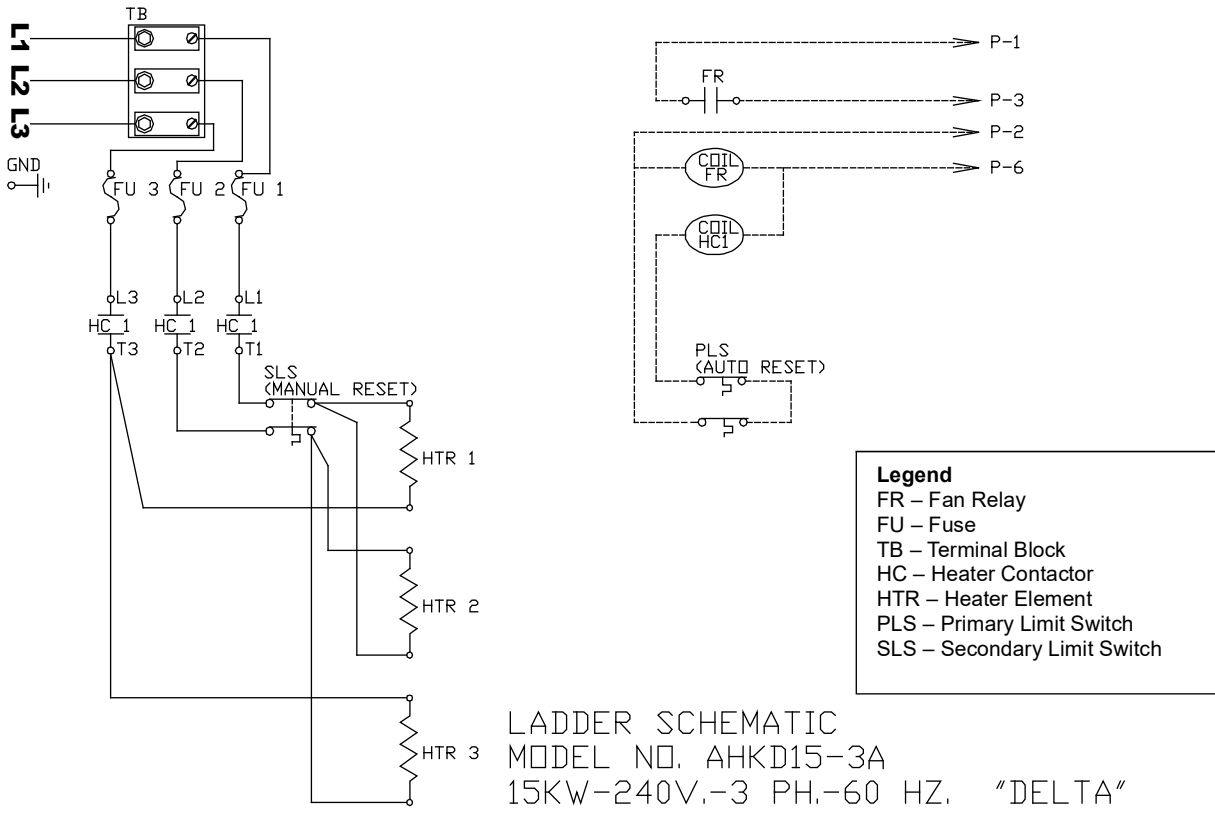

Wiring is subject to change. Always refer to the wiring diagram on the unit for the most up-to-date wiring.

WIRING DIAGRAM

WARNING

HIGH VOLTAGE!
 DISCONNECT ALL POWER BEFORE SERVICING OR INSTALLING THIS UNIT.
 MULTIPLE POWER SOURCES MAY BE PRESENT. FAILURE TO DO SO MAY
 CAUSE PROPERTY DAMAGE, PERSONAL INJURY OR DEATH.

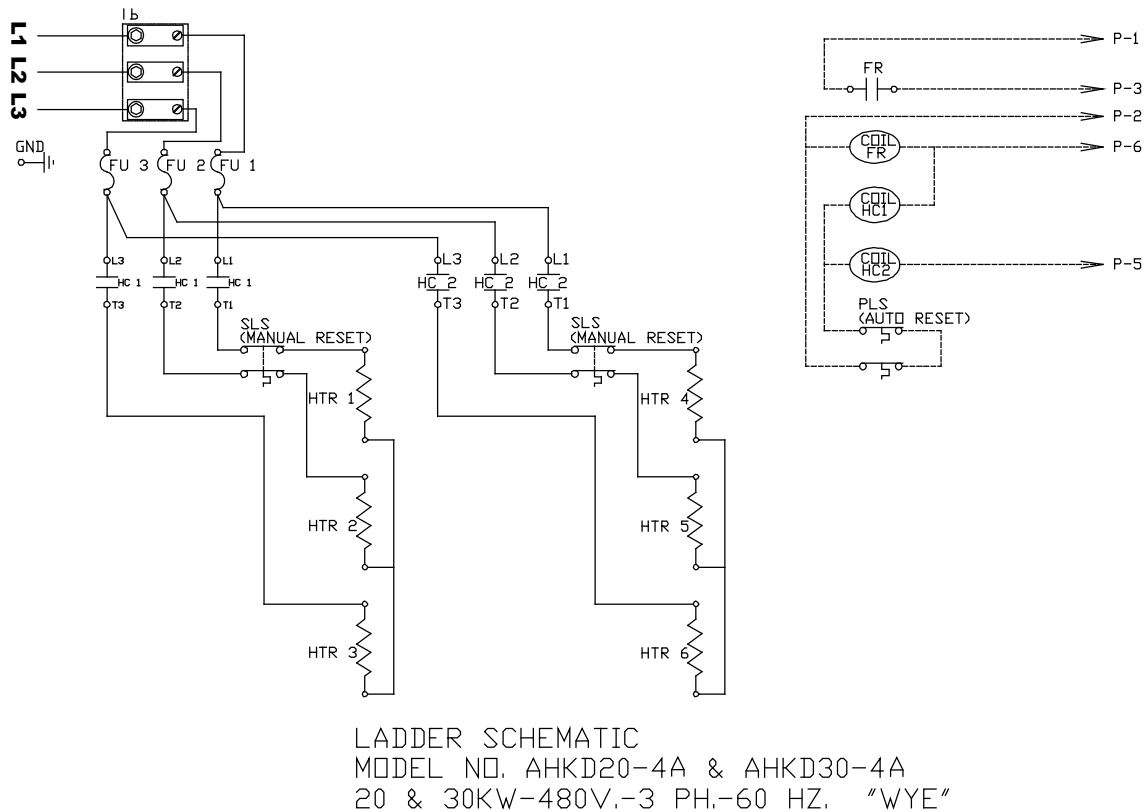
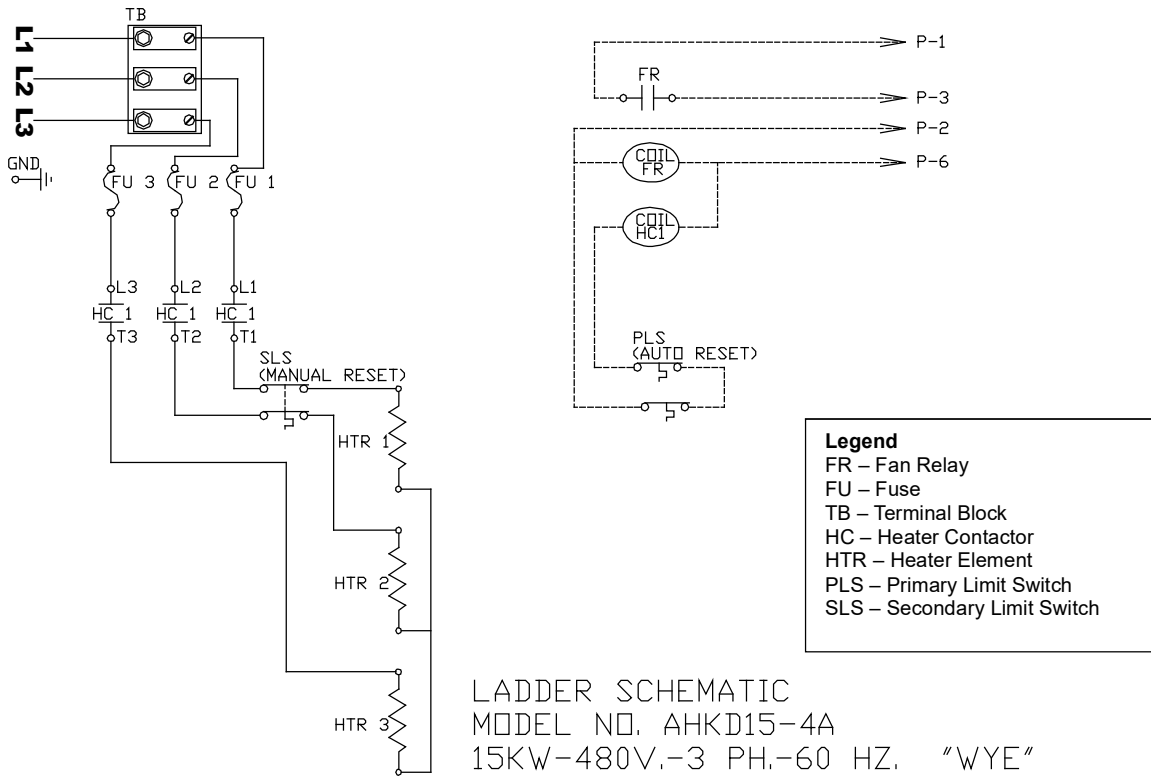

Wiring is subject to change. Always refer to the wiring diagram on the unit for the most up-to-date wiring.

THIS PAGE LEFT INTENTIONALLY BLANK

THIS PAGE LEFT INTENTIONALLY BLANK

THIS PAGE LEFT INTENTIONALLY BLANK

CUSTOMER FEEDBACK

Daikin is very interested in all product comments.

Please fill out the feedback form on the following link:

<https://daikincomfort.com/contact-us>

You can also scan the QR code on the right to be directed to the feedback page.



Our continuing commitment to quality products may mean a change in specifications without notice.

© 2013-2019, 2022 **DAIKIN COMFORT TECHNOLOGIES MANUFACTURING, L.P.**

19001 Kermier Rd. Waller, TX 77484

www.daikincomfort.com