

# HORIZONTAL ECONOMIZER (3-12.5 Ton) LIGHT COMMERCIAL ROOFTOP UNITS INSTALLATION INSTRUCTIONS

© 2019-2021, 2025 Daikin Comfort Technologies Manufacturing, Inc.  
19001 Kermier Rd., Waller, TX 77484  
www.daikincomfort.com  
P/N: IOD-7049E Date: July 2025

## ATTENTION INSTALLING PERSONNEL

As a professional installer you have an obligation to know the product better than the customer. This includes all safety precautions and related items.

Prior to actual installation, thoroughly familiarize yourself with this instruction manual. Pay special attention to all safety warnings. After during installation or repair it is possible to place yourself in a position which is more hazardous than when the unit is in operation.

Remember, it is your responsibility to install the product safely and to know it well enough to be able to instruct a customer in its safe use. Safety is a matter of common sense...a matter of thinking before acting. Most dealers have a list of specific good safety practices... follow them.

The precautions listed in this installation manual are intended as supplemental to existing practices.

However, if there is a direct conflict between existing practices and the content of this manual, the precautions listed here take precedence.

This product is designed and manufactured to permit installation in accordance with national codes. It is the installer's responsibility to install this unit in accordance with national codes and prevailing local codes and regulations.

## GENERAL INFORMATION

This installation and operating manual covers field installed horizontal economizers for Daikin commercial package models. These economizers are available with dry bulb or enthalpy sensors and are offered on 3 - 12.5 ton models. Economizers are for ultra low leak applications. This economizer kit must be used with a two stage thermostat.

## SAFETY CONSIDERATIONS

Installation and servicing of air conditioning equipment can be hazardous due to system pressure and electrical components. Only trained and qualified service personnel should install, repair, or service air conditioning equipment.

All operations should be performed by trained service personnel. When working on air conditioning equipment, observe precautions in the literature, tags and labels attached to the unit or accessory, and other safety precautions that may apply.

Follow all safety codes. Wear safety glasses and work gloves.



### WARNING

**ONLY PERSONNEL THAT HAVE BEEN TRAINED TO INSTALL, ADJUST, SERVICE, MAINTENANCE OR REPAIR (HEREINAFTER, "SERVICE") THE EQUIPMENT SPECIFIED IN THIS MANUAL SHOULD SERVICE THE EQUIPMENT.**

**THIS EQUIPMENT IS NOT INTENDED FOR USE BY PERSONS (INCLUDING CHILDREN) WITH REDUCED PHYSICAL, SENSORY OR MENTAL CAPACITIES, OR LACK OF EXPERIENCE AND KNOWLEDGE, UNLESS THEY HAVE BEEN GIVEN SUPERVISION OR INSTRUCTION CONCERNING USE OF THE APPLIANCE BY A PERSON RESPONSIBLE FOR THEIR SAFETY.**

**CHILDREN SHOULD BE SUPERVISED TO ENSURE THAT THEY DO NOT PLAY WITH THE EQUIPMENT.**

**THE MANUFACTURER WILL NOT BE RESPONSIBLE FOR ANY INJURY OR PROPERTY DAMAGE ARISING FROM IMPROPER SUPERVISION, SERVICE OR SERVICE PROCEDURES. IF YOU SERVICE THIS UNIT, YOU ASSUME RESPONSIBILITY FOR ANY INJURY OR PROPERTY DAMAGE WHICH MAY RESULT. IN ADDITION, IN JURISDICTIONS THAT REQUIRE ONE OR MORE LICENSES TO SERVICE THE EQUIPMENT SPECIFIED IN THIS MANUAL, ONLY LICENSED PERSONNEL SHOULD SERVICE THE EQUIPMENT. IMPROPER SUPERVISION, INSTALLATION, ADJUSTMENT, SERVICING, MAINTENANCE OR REPAIR OF THE EQUIPMENT SPECIFIED IN THIS MANUAL, OR ATTEMPTING TO INSTALL, ADJUST, SERVICE OR REPAIR THE EQUIPMENT SPECIFIED IN THIS MANUAL WITHOUT PROPER SUPERVISION OR TRAINING MAY RESULT IN PRODUCT DAMAGE, PROPERTY DAMAGE, PERSONAL INJURY OR DEATH.**



### WARNING

**HIGH VOLTAGE!  
DISCONNECT ALL POWER BEFORE SERVICING OR INSTALLING THIS UNIT. MULTIPLE POWER SOURCES MAY BE PRESENT. FAILURE TO DO SO MAY CAUSE PROPERTY DAMAGE, PERSONAL INJURY OR DEATH.**



### WARNING

**DO NOT BYPASS SAFETY DEVICES.**



## ECONOMIZER GENERAL INFORMATION

Economizers are used to let free-cooling into the building when the outdoor air is cool enough and therefore reducing the need to turn on your compressors for mechanical cooling. This is accomplished by the controller sending a command to the economizer to open the damper when the outside air is suitable to be used for free cooling. This offers an energy savings to the building owner. In the event that free-cooling alone cannot satisfy the cooling demand in the space, the controller will activate the 1st stage of mechanical cooling and both free-cooling and mechanical cooling will be used together.

If the outside air dampers are open and the air becomes too warm (or humid with enthalpy control) the dampers will be commanded to modulate to the minimum position (ventilation) set point. When doing so the compressors will provide mechanical cooling to the building. When the unit is in heating mode the economizer will be at minimum position.

Economizers are also able to open to a minimum position and offer fresh air (ventilation air) into the building to meet code requirements. The controller has the ability to set 2 separate minimum position settings for 2 speed units.

Economizers are provided with dampers, an actuator to control the damper movement, an outside air sensor (if required), a mixed air sensor (if required), a factory mounted controller (if required), all necessary economizer wiring, barometric relief dampers, and an economizer hood.

## ECONOMIZER PART NUMBERS

Description	Part#	Sensor	Chassis	Cabinet Height
Horizontal Ultra Low Leak	0270L02816	Dry Bulb	Small	39"
	0270L02817	Dry Bulb	Small	43"
	0270L02818	Dry Bulb	Small	53"
	0270L02819	Enthalpy	Small	39"
	0270L02820	Enthalpy	Small	43"
	0270L02821	Enthalpy	Small	53"
	0270L02822	DDC	Small	39"
	0270L02823	DDC	Small	43"
	0270L02824	DDC	Small	53"
	0270L02828	Dry Bulb	Medium	55"
	0270L02829	Enthalpy	Medium	55"
	0270L02830	DDC	Medium	55"

**TABLE 1 - ECONOMIZER PART NUMBERS**

## ECONOMIZER INSTALLATION

The 7.5 - 12.5 ton models have additional components mounted onto the horizontal return air panel and in the return air duct.

### TO INSTALL THE 3 - 6 TON HORIZONTAL ECONOMIZER, PERFORM THE FOLLOWING PROCEDURE:

The location for installation of horizontal economizers is in the return air section.

1. Open carton and inspect contents for damaged or missing parts.
2. Take Filter Access Panel off of unit. This panel can be discarded (See Figure 1).

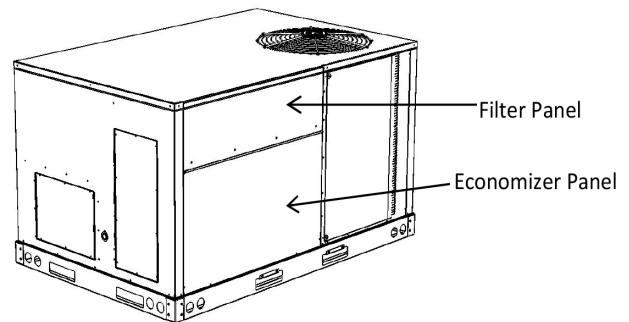

**FIGURE 1 - REMOVE PANELS**

3. Remove economizer panel from return air section of unit (See Figure 1). This panel can be discarded. Keep removed screws for use in later step.
4. Remove the horizontal return air opening cover and secure it over the downflow return opening per unit installation instructions (See horizontal duct clips).
5. Place economizer in return air section of unit aligned with the horizontal duct opening (See Figure 2).
6. Install the economizer cover panel using the screws removed in step 3. The holes in the economizer should line up with the holes in the cover panel (See Figure 2).

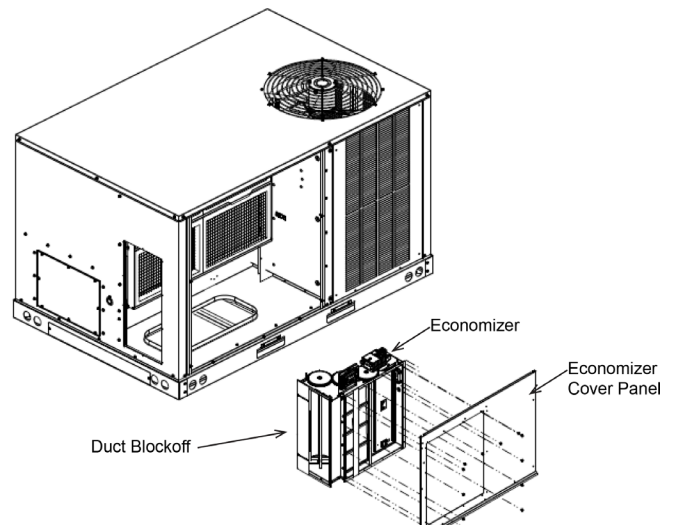

**FIGURE 2 - SLIDE ECONOMIZER INTO UNIT**

7. Apply gasket from the hardware bag to the mating flanges of pre-assembled economizer hood. Then fasten the hood to the economizer cover panel using provided screws (See Figure 3).

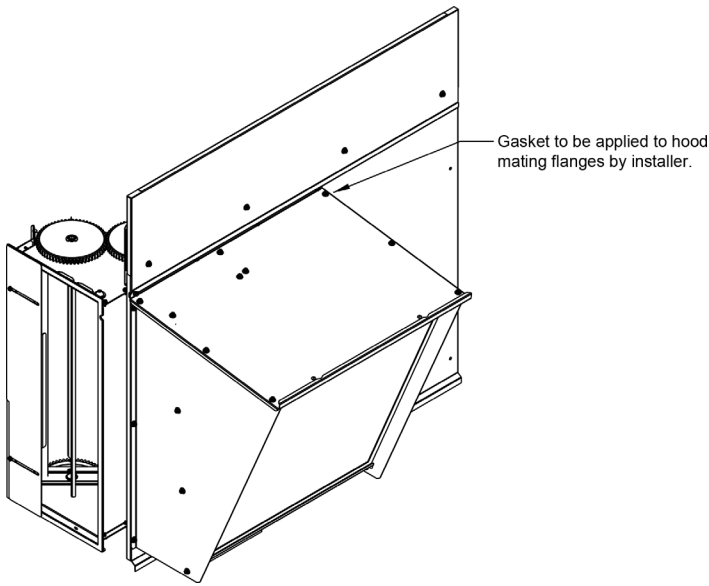

**FIGURE 3 - FULLY ASSEMBLED HOOD**

8. With economizer fully installed, loosen the duct blockoff and slide it toward the filter rack to minimize air by-pass (See Figure 4).

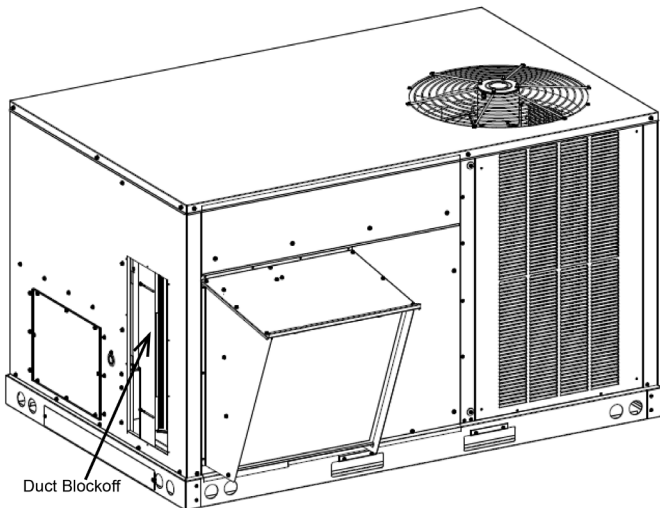

**FIGURE 4 - FULLY ASSEMBLED ECONOMIZER**

9. Leave the kit supplied filter access panel above the hood off at this point to access the controller and actuator. Controller and actuator are mounted directly to economizer (See Figure 5).

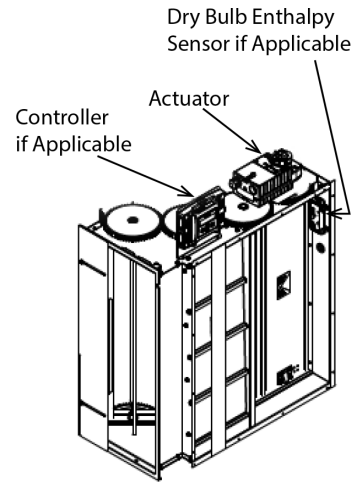

**FIGURE 5 - ACTUATOR AND CONTROLLER LOCATION**

**TO INSTALL THE 7.5 - 12.5 TON HORIZONTAL ECONOMIZER, PERFORM THE FOLLOWING PROCEDURE:**

1. Open carton and inspect contents for damaged or missing parts.
2. Take filter access panel off of unit. Keep for installation back on to unit when economizer installation is complete (See Figure 6).

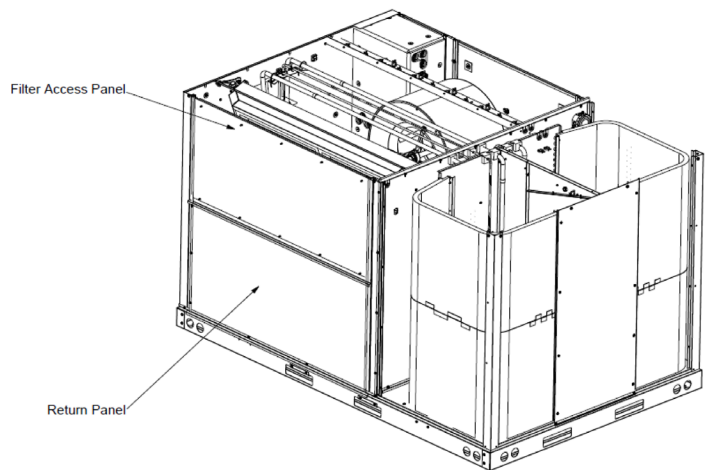

**FIGURE 6 - REMOVE PANELS**

3. Remove return panel from return air section of unit (See Figure 6). This panel can be discarded. Keep removed screws for use in later step.
4. Remove the horizontal return air opening cover and secure it over the downflow return opening per unit installation instructions (See horizontal duct clips). Keep removed screws for use in later step.
5. Mount the return air damper assembly and the outside air damper assembly to the unit using screws removed in steps 3 and 4 (See Figure 7).

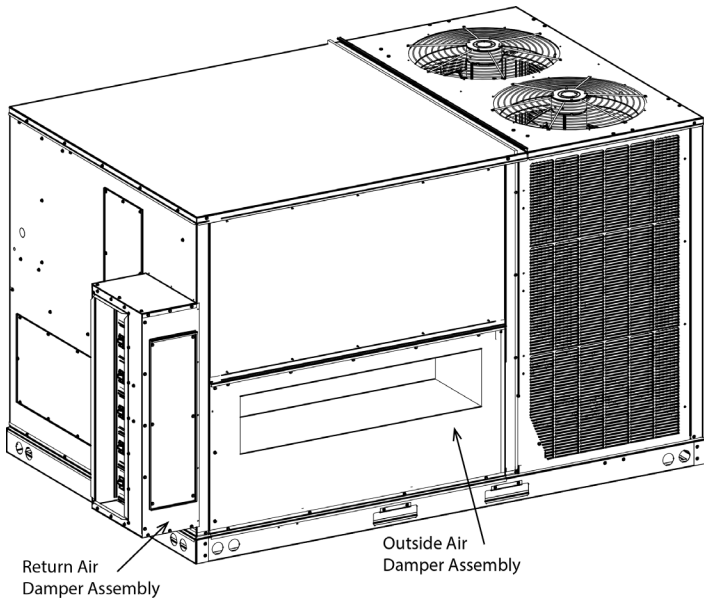

**FIGURE 7 - MEDIUM DAMPER ASSEMBLIES**

6. Fasten the fully assembled outside air damper hood to outside air damper assembly using provided screws (See Figure 8).

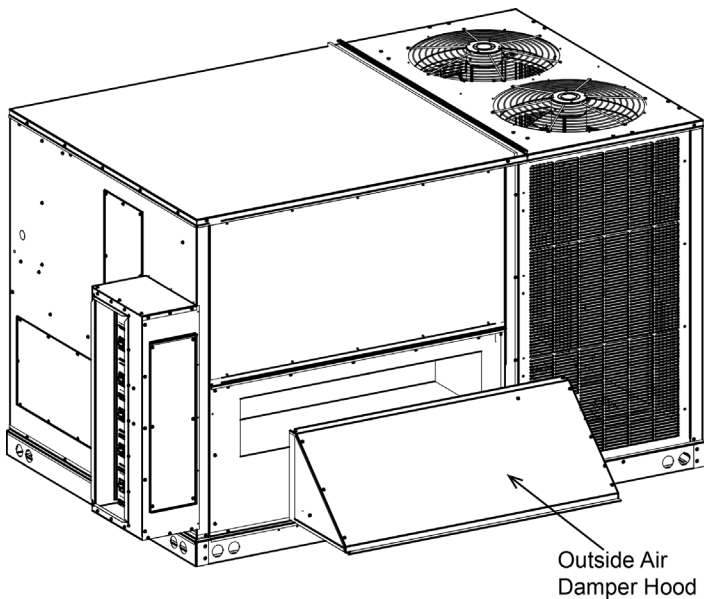

**FIGURE 8 - MEDIUM DAMPER HOOD**

7. Install the return duct onto the return air damper assembly.
8. Cut a 19" x 19" hole into the return side of the return duct at least 4" from the return air damper assembly.
9. Fasten the fully assembled barometric relief hood over the hole in the return duct using provided screws (See Figure 9).
10. Weatherproof seam where the return air damper assembly meets the unit and where the return air duct meet the return air damper with silicone or other approved sealant.

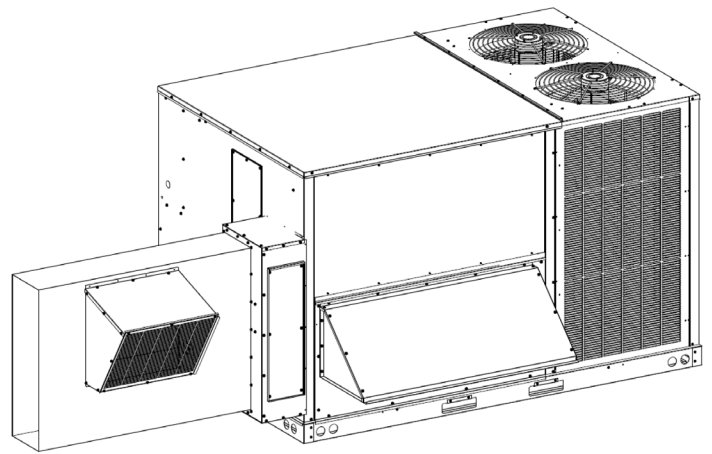

**FIGURE 9 - BAROMETRIC RELIEF HOOD**

11. Leave the filter access panel above the outside air damper hood off at this point to access the controller and actuator. Controller and actuator are mounted directly to outside air damper assembly (See Figure 10).

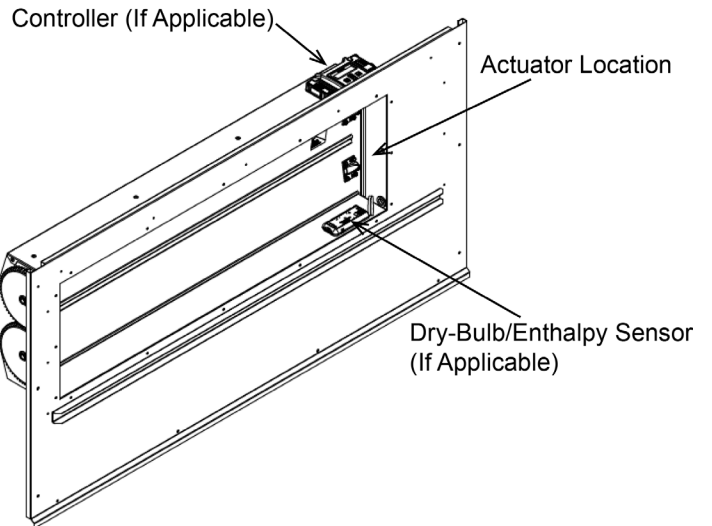

**FIGURE 10 - CONTROLLER AND ACTUATOR**

**ECONOMIZER WIRING INSTRUCTIONS FOR 3-6 TON UNITS:**

1. Remove the jumper plug from the factory installed economizer wire harness. The jumper plug is located on the partition panel in the return air compartment (See Figure 11).

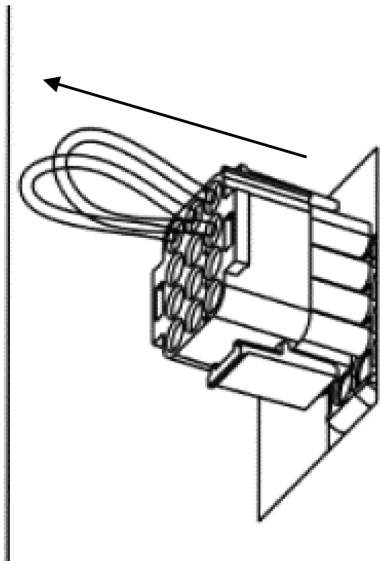

**FIGURE 11 - REMOVE ECONOMIZER JUMPER PLUG**

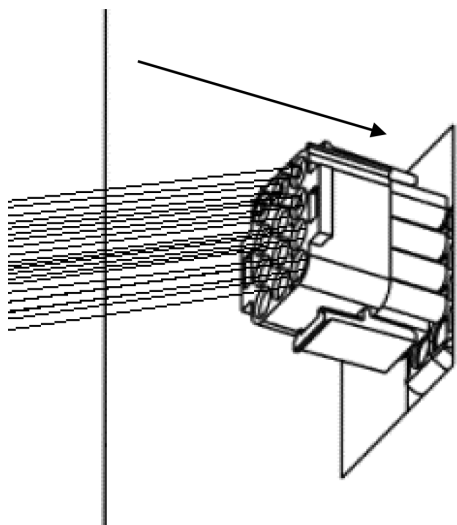
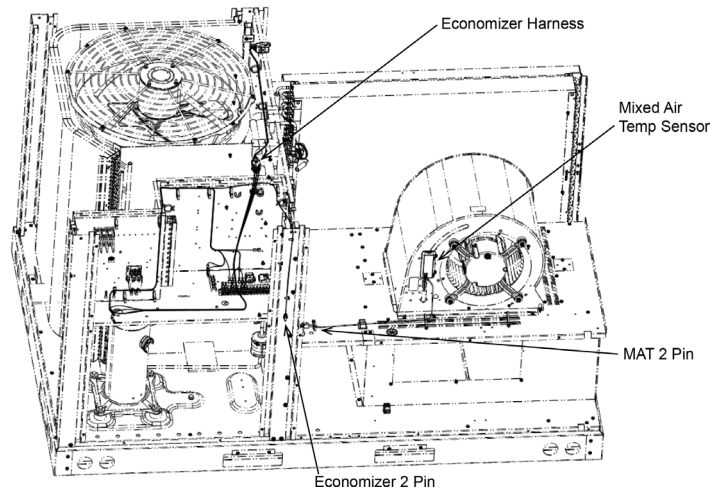

**FIGURE 12 - ATTACH ECONOMIZER HARNESS**

2. Plug in the wire harness provided with the economizer kit (See Figure 12).

**NOTE:** Economizer kits with DDC controls do not include the mixed air temperature sensor. If your unit has the DDC controls option installed, confirm that the supply air temperature sensor has been installed and is functioning as specified in the iLINQ User Manual and skip to step 6.

3. Remove the indoor fan compartment cover and locate the factory installed mixed air temperature harness. This harness consists of two black wires and a two pin connector. On some gas models, this harness may not be factory installed. If your unit does not have this harness, skip to step 4. Once the harness is located, install the mixed air temperature sensor provided with the kit on the side of the blower housing. Connect the mixed air temperature sensor to the factory harness using the adapter harness provided with the economizer kit (See Figure 13). Reinstall the indoor fan compartment cover. Skip to step 5.



**FIGURE 13 - INDOOR FAN SECTION / MIXED AIR SENSOR 3-6 TON**

4. Some gas units may not have a factory installed mixed air temperature harness in the blower compartment. In this case, install the mixed air temperature sensor in the return air compartment (See Figure 14 for mounting location). Use the 2 cutting screws provided with the kit to mount the sensor. Disconnect the existing mixed air temperature sensor wire harness from the W7220 control module. Connect the mixed air temperature sensor to the W7220 controller using the harness provided with the kit (See Figure 15). Secure the disconnected mixed air temperature harness so that it does not interfere with any moving parts.

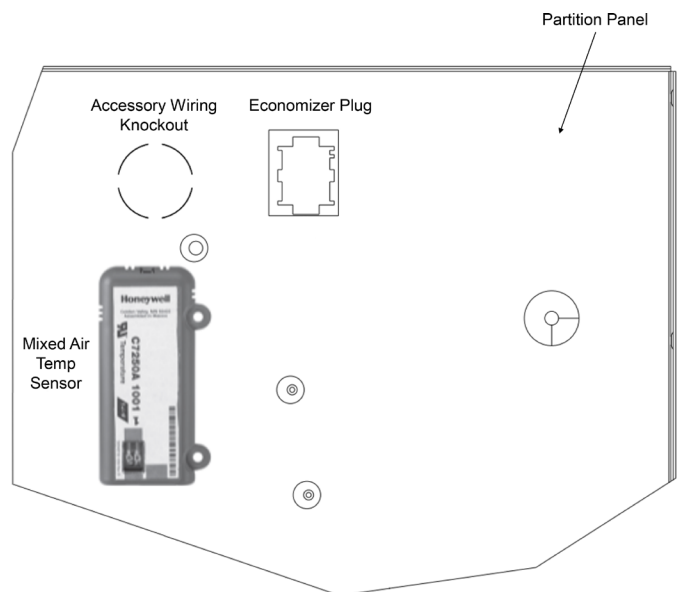

**FIGURE 14**

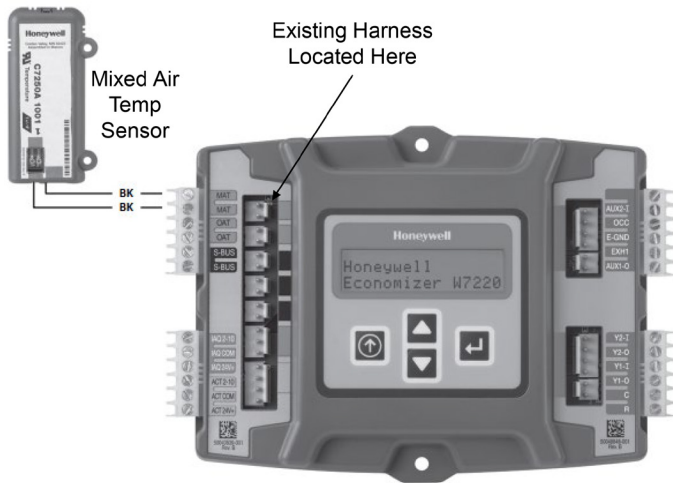

FIGURE 15

5. Program the W7220 controller to the needs of your specific application. Table 6 below details the Menu structure of the controller.
6. Reinstall the unit's filter access panel above economizer.

### ECONOMIZER WIRING INSTRUCTIONS FOR 7.5-12.5 TON UNITS:

1. Remove the jumper plug from the factory installed economizer wire harness. The jumper plug is located on the partition panel in the return air compartment (See Figure 11).
2. Plug in the wire harness provided with the economizer kit (See Figure 12).

**NOTE:** Economizer kits with DDC controls do not include the mixed air temperature sensor. If your unit has the DDC controls option installed, confirm that the supply air temperature sensor has been installed and is functioning as specified in the iLINQ User Manual and skip to step 6.

**NOTE: FOR 7.5 TO 12.5 TON UNITS, THE FACTORY INSTALLED ECONOMIZER WIRE HARNESS AND JUMPER PLUG WILL BE HANGING FROM THE EVAPORATOR COIL BLOCKOFF (SEE FIGURE 16.)**

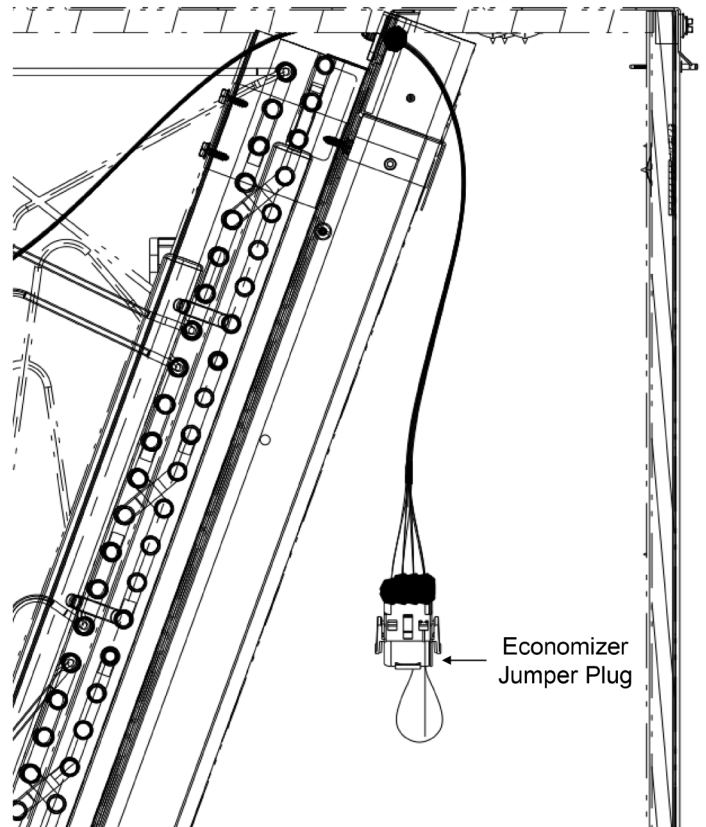

FIGURE 16

3. Connect the return air damper actuator to the W7220 controller on the outdoor damper assembly as shown in the 7.5-12.5 Ton wiring diagram on page 17.
4. Remove the indoor fan compartment cover and locate the factory installed mixed air temperature harness. This harness consists of two black wires and a two pin connector. Once the harness is located, install the mixed air temperature sensor provided with the kit on the side of the blower housing. Connect the mixed air temperature sensor to the harness using the adapter harness provided with the economizer kit (See Figure 17). Reinstall the indoor fan compartment cover.

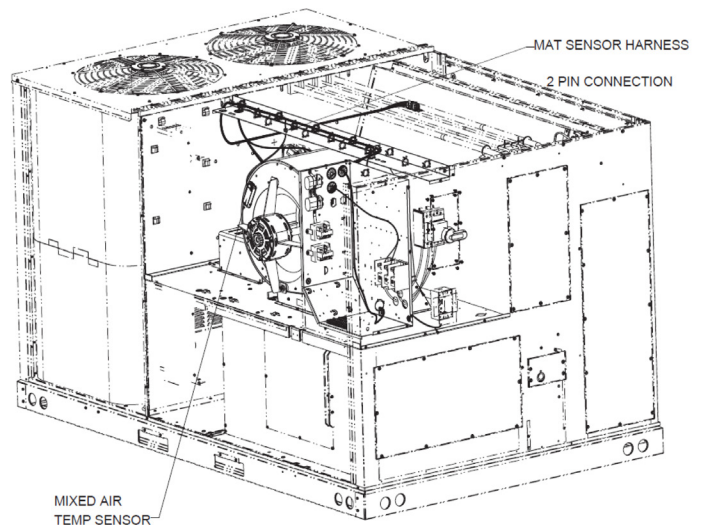

FIGURE 17 - INDOOR FAN SECTION / MIXED AIR SENSOR  
7.5-12.5 TON

5. Program the W7220 controller to the needs of your specific application. Table 6 below details the Menu structure of the controller.
6. Reinstall the unit's filter access panel above economizer.

**ECONOMIZER WIRING INSTRUCTIONS FOR 7.5 - 10 TON HP INVERTER UNITS:**

1. Plug in the wire harness provided with the economizer kit (See Figure 18).

**NOTE: FOR 7.5 TO 10 TON HP INVERTER UNITS, THE FACTORY INSTALLED ECONOMIZER WIRE HARNESS AND JUMPER PLUG WILL BE HANGING FROM THE EVAPORATOR COIL BLOCKOFF (SEE FIGURE 18).**

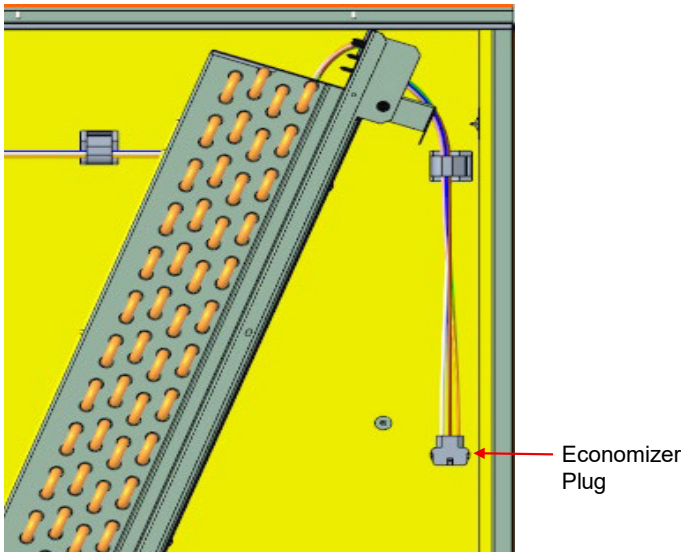

**FIGURE 18**

2. Connect the return air damper actuator to the W7220 controller on the outdoor damper assembly as shown in the 7.5-10 Ton DVH economizer wire diagram on page 19.
3. Program the W7220 controller to the needs of your specific application. Table 6 below details the Menu structure of the controller.
4. Reinstall the unit's filter access panel above economizer.

**HORIZONTAL ECONOMIZER STATIC PRESSURE DROP VALUES:**

See the tables below for static pressure drop values when the horizontal economizer kit is installed.

**SMALL CHASSIS ECONOMIZER STATIC PRESSURE LOSS IN. W.C.**

3-6 Tons		
Horizontal Economizer Static Pressure Drop		
Cabinet	CFM	Horizontal
3 Ton	900	.06"
	1,200	.11"
	1,500	.16"
4 Ton	1,200	.11"
	1,600	.19"
	2,000	.29"
5 Ton	1,500	.18"
	2,000	.30"
	2,500	.45"
6 Ton	1,800	.24"
	2,400	.41"
	3,000	.61"

**TABLE 2 - 3-6 TON STATIC PRESSURE DROP**

**MEDIUM CHASSIS ECONOMIZER STATIC PRESSURE LOSS IN. W.C.**

7.5 - 12.5 Tons		
Horizontal Economizer Static Pressure Drop		
Cabinet	CFM	Horizontal
7.5 Ton	2,250	.05"
	3,000	.07"
	3,750	.13"
8.5 Ton	2,550	.07"
	3,400	.13"
	4,250	.18"
10 Ton	3,000	.07"
	4,000	.12"
	5,000	.19"
12.5 Ton	3,750	.09"
	5,000	.15"
	6,250	.24"

**TABLE 3 - 7.5 - 12.5 STATIC PRESSURE DROP**

**NOTE: TABLE 3 ALSO APPLIES TO MEDIUM CHASSIS HP INVERTER UNITS FROM 7.5 TON TO 10 TON.**

**INTERFACE OVERVIEW**

This Section describes how to use the Economizer's user interface for:

- Keypad and menu navigation
- Settings and parameter changes
- Menu structure and selection
- If unit is equipped with the DDC controls option, refer to the iLINQ user manual for controls set up.

**USER INTERFACE**

The user interface consists of an LCD display and a 4-button keypad on the front of the economizer module. The LCD is a 16 character by 2 line dot matrix display.

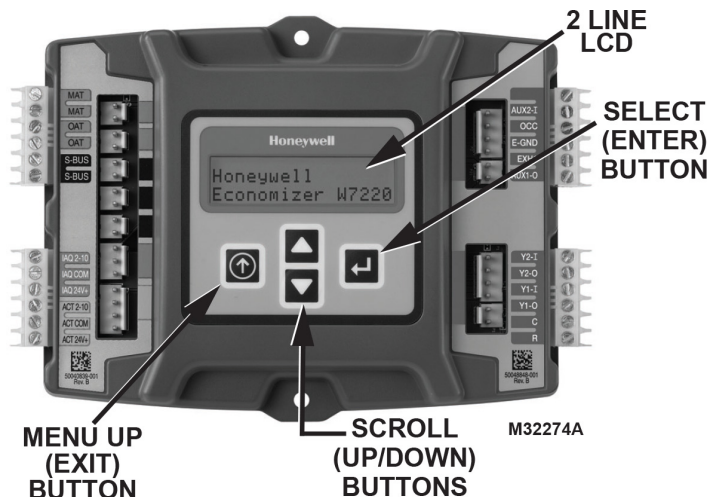

FIGURE 19 - ECONOMIZER LCD AND KEYPAD LAYOUT.

### KEYPAD

The four navigation buttons shown in Figure 19 are used to scroll through the menus and menu items, select menu items, and change to parameter and configuration settings.

### USING THE KEYPAD WITH MENUS

- To use the keypad when working with menus:
- Press the ▲ button to move to the previous menu.
- Press the ▼ button to move to the next menu.
- Press the ← button (Enter) to display the first item in the currently displayed menu.
- Press the ⌚ button (Menu up) to exit a menu's item and return to the list of menus.

### USING THE KEYPAD WITH SETTINGS AND PARAMETERS

- To use the keypad when working with Setpoints, System and Advanced Settings, Checkout tests, and Alarms:
- Navigate to the desired menu.
- Press the ← Button (Enter) to display the first item in the currently displayed menu.
- Use the ▲ and ▼ buttons to scroll to the desired parameter.
- Press the ← button (Enter) to display the value of the currently displayed item.
- Press the ▲ button to increase (change) the displayed parameter value.<sup>a</sup>
- Press the ▼ button to decrease (change) the displayed parameter value.<sup>a</sup>
- Press the ← button to accept the displayed value and stores it in non-volatile RAM.
- CHANGE STORED displays.
- Press the ⌚ button (Menu Up/Exit) to return to the previous menu.

<sup>a</sup>When values are displayed, pressing and holding the ▲ or ▼ button causes the display to automatically increment.

### MENU STRUCTURE

Table 6 illustrates the complete hierarchy of menus and parameters for the JADE™ Economizer system.

The Menus in display order are:

- STATUS
- SETPOINTS
- SYSTEM SETUP
- ADVANCED SETUP
- CHECKOUT
- ALARMS

## IMPORTANT

*Table 6 illustrates the complete hierarchy.*

*Your menu parameters will be different depending on your configuration.*

*For example, if you do not have a DCV (CO<sub>2</sub>) sensor then none of the DCV parameters appear and only MIN POS will display.*

*If you have a CO<sub>2</sub> sensor, the DCV MIN and DCV MAX will appear AND if you have 2-speed fan, DCV MIN (high and low speed) and DCV MAX (high and low speed will appear).*

### SETUP AND CONFIGURATION

Before placed into service, the JADE™ Economizer module must be setup and configured for the installed system.

## IMPORTANT

*During setup, the Economizer module is live at all times.*

The setup process uses a hierarchical menu structure that is easy to use. You press the ▲ and ▼ arrow buttons to move forward and backward through the menus and press the ← button to select and confirm setup item changes.

### TIME-OUT AND SCREENSAVER

When no buttons have been pressed for 10 minutes, LCD displays a screen saver, which cycles through the Status items. Each Status items displays in turn and cycles to the next item after 5 seconds.

## DRY BULB SENSOR

The C7250 dry bulb sensor comes factory installed and wired on the economizer for dry bulb outside air (See **economizer wiring diagrams on pages 15 and 16**). Units equipped with the DDC controls option come with the 0130L00227 dry bulb outdoor air temperature sensor factory installed near the condenser fan section of the unit. Refer to the Daikin iLINQ user manual for more information on configuration settings. It will be located in the outdoor air stream. When the temperature falls below the controller set point this allows the unit to economize with outdoor air only. In the event that the outside air alone cannot provide the cooling load required, the controller will also run the unit's 1st stage of cooling simultaneously. The dry bulb sensor has a controller setpoint default of 63 degrees, and has a range of 48 – 80 degrees. California's Title 24 requires economizer high limits per **Table 4**.

**NOTE: A SECOND C7250 SENSOR IS PROVIDED IN THE PARTS KIT TO BE USED AS THE MIXED AIR SENSOR, AND IS FIELD INSTALLED (SEE ECONOMIZER WIRING DIAGRAMS PAGES 15 AND 16).**



**FIGURE 20 – C7250 DRY BULB AND MIXED AIR TEMPERATURE SENSOR**

**TABLE 4. CALIFORNIA TITLE 24 REGIONAL HIGH LIMIT DRY BULB TEMPERATURES SETTINGS**

DEVICE TYPE <sup>a</sup>	CLIMATE ZONES	REQUIRED HIGH LIMIT (Economizer Off When:)
<b>FIXED Dry Bulb</b>	1, 3, 5, 11-16	OA T exceeds 75 °F
	2, 4, 10	OA T exceeds 73 °F
	6, 8, 9	OA T exceeds 71 °F
	7	OA T exceeds 69 °F
<b>DIFFERENTIAL Dry Bulb</b>	1, 3, 5, 11-16	OA T exceeds RA T
	2, 4, 10	OA T exceeds RA T minus 2 °F
	6, 8, 9	OA T exceeds RA T minus 4 °F
	7	OA T exceeds RA T minus 6 °F
<b>FIXED Enthalpy<sup>b</sup> and FIXED Dry Bulb</b>	ALL	OA enthalpy exceeds 28 Btu/lb of dry air <sup>b</sup> or OA T exceeds 75 °F

<sup>a</sup> Only the high limit control devices listed are allowed to be used and at the setpoints listed. Others such as Dew Point, Fixed Enthalpy, Electronic Enthalpy, and Differential Enthalpy Controls may not be used in any climate zone for compliance with Section 140.4(e)1 unless approval for use is provided by the Energy Commission Executive Director.

<sup>b</sup> At altitudes substantially different than sea level, the Fixed Enthalpy limit value shall be set to the enthalpy value at 75 °F and 50% relative humidity. As an example, at approximately 6,000 foot elevation, the fixed enthalpy limit is approximately 30.7 Btu/lb.

**OA T = Outdoor Air Temperature | RA T = Return Air Temperature**

## OPTIONAL ENTHALPY SENSOR

The economizer comes standard with a (C7250) dry bulb outside air sensor. A field installed (C7400S) enthalpy sensor kit is available to control the free-cooling change-over with both temperature and humidity. Units equipped with the DDC controls option can be configured to control the free-cooling change-over with both temperature and humidity by field installing the optional outdoor air temperature/humidity sensor (0130L00223). This sensor replaces the factory installed dry bulb outdoor air sensor. Refer to the Daikin iLinq user manual and unit wiring diagram for more information on wiring and configuration settings. When the C7400S enthalpy is used, the C7250A dry bulb sensor must be removed. When the enthalpy is below the set point this allows the unit to economize with outdoor air only. If all of the values calculated are below the minimum values this will allow the economizer to economize. Mount enthalpy sensor in the outdoor section of the economizer. Mount in same location as the C7250 sensor, which is to be removed. The Enthalpy Sensor C7400S gets wired into controller. Sensor is to be located in the outside air stream. The DIP switches must be set to OFF-OFF-OFF when the C7400S sensor is used as an outside air enthalpy sensor (See Table 5 and Figure 21).



**FIGURE 21 – OPTIONAL C7400S ENTHALPY SENSOR**

**NOTE: THE C7400S SENSOR CAN ALSO BE USED FOR A DIFFERENTIAL RETURN AIR SENSOR. THIS CASE SET THE DIP SWITCHES TO ON-OFF-OFF (SEE TABLE 4).**

## CO2 SENSOR

A CO2 Sensor can be mounted in the return air duct of the unit or wall mounted in the space served by the unit. Any CO2 Sensor with a 2-10 VDC or 0-10 VDC output can be used. If a 0-10 VDC sensor is used, see note g on page 15. The CO2 sensor connects to the IAQ wire leads provided with the economizer assembly.

## DIFFERENTIAL RETURN SENSORS

Differential return sensors are to be mounted in the return air duct. The C7400S sensor can be used for differential return dry bulb or enthalpy. See **Table 5** to set DIP switches appropriately. Mount differential sensor in return duct and wire per diagrams in this booklet. If unit is equipped with the DDC controls option, the field installed space temperature sensor or space temperature/humidity sensor can be used for differential economizer control. Refer to the iLINQ user manual for controls set up.

**TABLE 5. C7400S DIP SWITCH SETTINGS**

USE	DIP SWITCH POSITIONS <i>for Switches 1, 2, &amp; 3</i>		
	1	2	3
<b>DA<sup>a</sup></b>	OFF	ON	OFF
<b>RA<sup>b</sup></b>	ON	OFF	OFF
<b>OA<sup>c</sup></b>	OFF	OFF	OFF
<sup>a</sup> DA = Discharge Air or Supply Sensor <sup>b</sup> RA = Return Air <sup>c</sup> OA = Outside Air			

## ECONOMIZER SEQUENCE OF OPERATIONS FOR W7220

— WIRING OF CONTROLLER (SEE WIRING DIAGRAM) —

1. A call for cooling comes from room thermostat.
2. The enthalpy sensor determines if the atmospheric conditions are conducive for using outside air for cooling  
If YES, go to step 3.  
If NO, or if outdoor air temperature rises above enthalpy set point, go to step 4.
3. The outside air dampers open and modulate to maintain a mixed air temperature (outside air + indoor air) of 53 degrees F (this is adjustable on the controller. Default is 53 degrees). If the outdoor air is insufficient to satisfy the thermostat alone and a second stage of cooling is required, the compressor starts and works in conjunction with the economizer to cool the space (Go to step 5.)
4. Outdoor air dampers open to minimum position and the compressor engages to provide mechanical cooling.
5. When the thermostat is satisfied the outside air dampers return to the minimum position.  
**NOTE:** If unit is equipped with the DDC controls option, refer to the iLINQ user manual for the economizer sequence of operation.

TABLE 6. MENU STRUCTURE<sup>a</sup>

MENU	PARAMETER	PARAMETER DEFAULT VALUE	PARAMETER RANGE and INCREMENT <sup>b</sup>	NOTES
STATUS	ECON AVAIL	NO	YES/NO	YES = economizing available; the system can use Outdoor Air for free cooling when required.
	ECONOMIZING	NO	YES/NO	YES = Outdoor Air being used for 1st stage cooling.
	OCCUPIED	NO	YES/NO	YES = OCC signal received from space thermostat or Unitary Controller. YES = 24 Vac on terminal OCC   NO = 0 Vac on terminal OCC.
	HEAT PUMP	n/ac <sup>c</sup>	COOL HEAT	Displays COOL or HEAT when system is set to heat pump (non- conventional)
	COOL Y1-IN	OFF	ON/OFF	Y1-I signal from Space Thermostat or Unitary Controller for Cooling Stage 1. ON = 24 Vac on term Y1-I   OFF = 0 Vac on term Y1-I
	COOL Y1-OUT	OFF	ON/OFF	Cool Stage 1 Relay Output to mechanical cooling (Y1-OUT terminal).
	COOL Y2-IN	OFF	ON/OFF	Y2-I signal from space thermostat or Unitary Controller for Second Stage Cooling ON = 24 Vac on term Y2-I   OFF = 0 Vac on term Y2-I
	COOL Y2-OUT	OFF	ON/OFF	Cool Stage 2 Relay Output to mechanical cooling (Y2-OUT terminal).
	MA TEMP	__._ °F	-40 to 150 °F	Displays value of measured mixed air from MAT sensor. Displays __._ °F if not connected, short, or out- of-range.
	DA TEMP	__._ °F	-40 to 150 °F	Displays when Discharge Air Sylk Bus sensor is connected and displays measured discharge air temperature. Displays __._ °F if sensor sends invalid value, if not connected, short or out-of-range.
	OA TEMP	__._ °F	-40 to 140 °F	Displays measured value of outdoor air temperature. Displays __._ °F if sensor sends invalid value, if not connected, short or out-of-range.
	OA HUM	__ %	0 to 100%	Displays measured value of outdoor humidity from OA Sylkbus sensor. Displays __ % if not connected, short, or out- of-range.
	RA TEMP	__._ °F	0 to 140 °F	Displays measured value of return air temperature from RA Sylk Bus sensor. Displays __._ °F if sensor sends invalid value, if not connected, short or out-of-range.
	RA HUM	__ %	0 to 100%	Displays measured value of return air humidity from RA Sylkbus sensor. Displays __ % if sensor sends invalid value, if not connected, short or out-of-range.
	IN CO2	___ ppm	0 to 2000 ppm	Displays value of measured CO2 from CO2 sensor. Invalid if not connected, short or out-of-range. May be adjusted in Advanced menu by Zero offset and Span. See note on page 15 concerning C7632 sensor <sup>g</sup> .
	DCV STATUS	n/a	ON/OFF	Displays ON if above setpoint and OFF if below setpoint, and ONLY if a CO2 sensor is connected.
DAMPER OUT	2.0V	2.0 to 10.0 V	Displays output voltage or position to the damper actuator <sup>e</sup> .	

TABLE 6. MENU STRUCTURE<sup>a</sup> (cont.)

MENU	PARAMETER	PARAMETER DEFAULT VALUE	PARAMETER RANGE and INCREMENT	NOTES
STATUS (cont.)	ACT POS	n/a	0 to 100%	Displays actual position of actuator.
	ACT COUNT	n/a	1 to 65,535	Displays number of times actuator has cycled. One cycle equals the sum of 180° of movement in any direction.
	ACTUATOR	n/a	OK/Alarm (on Alarm menu)	Displays Error if voltage or torque is below actuator range
	EXH1 OUT	OFF	ON/OFF	Output of EXH1 terminal. Displays ON when damper position reaches programmed percentage setpoint. ON = 24 Vac Output; OFF = No Output.
	EXH2 OUT	OFF	ON/OFF	EXHAUST STAGE 2 RELAY OUTPUT Output of AUX terminal; displays only if AUX = EXH2 ON = relay closed OFF = relay open
	ERV	OFF	ON/OFF	ENERGY RECOVERY UNIT RELAY OUTPUT Output of AUX terminal; displays only if AUX = ERV ON = relay closed OFF = relay open
	MECH COOL ON	0	0, 1, or 2	Output of AUX terminal; displays only if AUX = ERV
	FAN SPEED	n/a	LOW or HIGH	SUPPLY FAN SPEED Displays speed setting of fan on a 2-speed fan unit.
	W (HEAT IN)	n/a	ON/OFF	HEAT DEMAND STATUS Displays status of heat demand on a 2-speed fan unit.
SETPPOINTS	MAT SET	53°F (12°C)	38°F to 65°F (3°C to 18°C); increment by 1°	MIXED AIR SET POINT Setpoint determines where the economizer will modulate the OA damper to maintain the mixed air temperature.
	LOW T LOCK	32°F (0°C)	38°F to 65°F (3°C to 18°C); increment by 1°	COMPRESSOR LOW TEMPERATURE LOCKOUT Setpoint determines outdoor temperature when the mechanical cooling cannot be turned on. Commonly referred to as the compressor lockout.
	DRYBLB SET	63°F (17°C)	48°F to 80°F (9°C to 27°C); increment by 1°	OA DRY BULB TEMPERATURE CHANGEOVER SETPOINT Setpoint determines where the economizer will assume outdoor air temperature is good for free cooling; e.g.: at 63°F (17°C), unit will economize at 62°F (16.7°C) and below and not economize at 64°F (17.8°C) and above. There is a 2°F (1.1°C) deadband. DRYBULB SET is only displayed if the economizer has a single dry bulb sensor
	DRYBLB DIF (Available firmware 1.15, June 2018, and later.)	0°F	0 to 6°F; increment by 2	Drybulb Differential will only show if using dual drybulb, i.e., when an outdoor air temperature sensor C7250 is attached to OAT terminals, and a C7400S sensor is wired to S-Bus and configured for RAT (return air). Free cooling will be assumed whenever OA Temp is below RAT minus this drybulb differential setting.
	ENTH CURVE	ES3	ES1, ES2, ES3, ES4, or ES5	ENTHALPY CHANGEOVER CURVE (Requires enthalpy sensor option) Enthalpy boundary “curves” for economizing using single enthalpy.
	DCV SET	1100ppm	500 to 2000 ppm increment by 100	DEMAND CONTROLLED VENTILATION SET POINT Displays only if CO2 sensor is connected. Setpoint for Demand Control Ventilation of space. Above the setpoint, the OA dampers will modulate open to bring in additional OA to maintain a space ppm level below the setpoint.

TABLE 6. MENU STRUCTURE<sup>a</sup> (cont.)

MENU	PARAMETER	PARAMETER DEFAULT VALUE	PARAMETER RANGE and INCREMENT	NOTES
SETPOINTS (cont.)	MIN POS L	3.2 V	2 to 10 vdc	VENTILATION MINIMUM POSITION at LOW SPEED. Displays ONLY if used on 2 speed units and CO <sub>2</sub> sensor is not used.
	MIN POS H	2.8 V	2 to 10 vdc	VENTILATION MINIMUM POSITION at HIGH SPEED. Displays ONLY if used on 2 speed units and CO <sub>2</sub> sensor is not used.
	VENTMAX L	2.8 V	2 to 10 Vdc	DCV MAXIMUM DAMPER POSITION at LOW SPEED Requires CO <sub>2</sub> sensor to be connected.
	VENTMAX H	4.4 V	2 to 10 Vdc	DCV MAXIMUM DAMPER POSITION at HIGH SPEED Requires CO <sub>2</sub> sensor to be connected.
	VENTMIN L	2.25 V	2 to 10 Vdc	DCV MINIMUM DAMPER POSITION at LOW SPEED. Requires CO <sub>2</sub> sensor to be connected.
	VENTMIN H	2.8 V	2 to 10 Vdc	DCV MINIMUM DAMPER POSITION at HIGH SPEED. Requires CO <sub>2</sub> sensor to be connected.
	ERV OAT SPd	32°F (0°C)	0°F to 50°F (-18°C to 10°C); increment by 1°	ENERGY RECOVERY VENTILATION UNIT OUTDOOR AIR TEMPERATURE SETPOINT Only displayed when AUX1 O = ERV
	EXH1 SET	50%	0 to 100% increment by 1°	EXHAUST FAN SETPOINT for single speed units. Based on OA Damper position to activate power exhaust.
	EXH1 L SET	65%	0 to 100% increment by 1°	EXHAUST FAN SETPOINT at LOW SPEED (2-speed unit) Setpoint for damper position when exhaust fan is powered by the economizer.
	EXH1 H SET	50%	0 to 100% increment by 1°	EXHAUST FAN SETPOINT at HIGH SPEED (2-speed unit) Setpoint for damper position when exhaust fan is powered by the economizer.
	EXH2 L SET	80%	0 to 100% increment by 1°	EXHAUST FAN STAGE 2 SETPOINT at LOW SPEED Setpoint for damper position when exhaust fan is powered by the economizer. Only used when AUX1-O is set to EXH2. <i>NOTE: Standard power exhaust kits have only one speed therefore EXH2 is not applicable.</i>
	EXH2 H SET	75%	0 to 100%; increment by 1	EXHAUST FAN STAGE 2 SETPOINT at LOW SPEED Setpoint for damper position when exhaust fan is powered by the economizer. Only used when AUX1-O is set to EXH2. <i>NOTE: Standard power exhaust kits have only one speed therefore EXH2 is not applicable.</i>

TABLE 6. MENU STRUCTURE<sup>a</sup> (cont.)

MENU	PARAMETER	PARAMETER DEFAULT VALUE	PARAMETER RANGE and INCREMENT	NOTES
SYSTEM SETUP	INSTALL	01/01/10		Display order = MM/DD/YY Setting order = DD, MM, then YY.
	UNITS DEG	°F	°F or °C	Sets economizer controller in degrees Fahrenheit or Celsius.
	EQUIPMENT	CONV	CONV HP	Always set to CONV even for heat pump
	AUX2 I	W1	Always set to W1	Always set to W1
	FAN TYPE	2 speed	1 speed / 2 speed	Sets economizer controller for operation of 1-speed or 2-speed indoor fan system. NOTE:Default fan settings may vary
	FAN CFM	5,000 cfm	100 to 15,000 cfm; increment by 100	UNIT DESIGN AIRFLOW (CFM) Enter ONLY if using DCVCAL ENA = AUTO
	AUX1 OUT	NONE	NONE ERV EXH2 SYS	Select OUTPUT for AUX1-O relay <ul style="list-style-type: none"> <li>• NONE = not configured (output is not used)</li> <li>• ERV= Energy Recovery Ventilation</li> <li>• EXH2 = second damper position 24 Vac out for second exhaust fan.</li> <li>• SYS = use output as an FDD remote alarm signal</li> </ul>
	OCC	INPUT	INPUT or ALWAYS	Always set to INPUT
	FACTORY DEFAULT	NO	NO or YES	Resets all setpoints to factory defaults when set to YES. LCD will briefly flash YES and change to NO but all parameters will change to factory default values.
ADVANCED SETUP	MA LO SET	45 °F (7 °C)	35 to 55 °F; (2° to 12°C) increment by 1°	MIXED AIR TEMPERATURE LOW LIMIT Temperature to activate Freeze Protection (close damper and alarm if temperature falls below setup value)
	FREEZE POS	CLO	CLO MIN	FREEZE PROTECTION DAMPER POSITION Damper position when freeze protection is active CLO = closed MIN = MIN POS or VENTMIN
	CO <sub>2</sub> ZERO	0 ppm	0 to 500 ppm; increment by 10	CO <sub>2</sub> ppm level to match CO <sub>2</sub> sensor start level.
	CO <sub>2</sub> SPAN	2,000 ppm	w	CO <sub>2</sub> ppm span to match CO <sub>2</sub> sensor.
	STG3 DLY	2.0h	0 min, 5 min, 15 min, then 15 min intervals. Up to 4h or OFF	COOLING STAGE 3 DELAY Delay after stage 2 for cool has been active. Turns on 2 <sup>nd</sup> stage of mechanical cooling when economizer is 1 <sup>st</sup> and mechanical cooling is 2 <sup>nd</sup> .
	SD DMPR POS	CLO	CLO or OPEN	Function NOT AVAILABLE with 2-speed mode.

TABLE 6. MENU STRUCTURE<sup>a</sup> (cont.)

MENU	PARAMETER	PARAMETER DEFAULT VALUE	PARAMETER RANGE and INCREMENT	NOTES
ADVANCED SETUP (cont.)	SD DMPR POS	CLO	CLO or OPEN	Function NOT AVAILABLE with 2-speed mode.
	DCVCAL ENA	MAN	MANUAL or AUTO	Turns on the DCV automatic control of the dampers. Resets ventilation. For single-speed units only.
	MAT T CAL	0.0 °F (or °C)	±2.5°F (±1.4°C)	MIXED AIR TEMPERATURE CALIBRATION Allows for the operator to adjust for an out of calibration mixed air temperature (MAT) sensor
	OA T CAL	0.0 °F (or °C)	±2.5°F (±1.4°C)	OUTSIDE AIR TEMPERATURE CALIBRATION Allows for the operator to adjust for an out of calibration outside air temperature (OAT) sensor
	OA H CAL	0% RH	±10% RH	OUTSIDE AIR HUMIDITY CALIBRATION Allows for the operator to adjust for an out of calibration outside air enthalpy sensor
	RA T CAL	0.0 °F (or °C)	±2.5°F (±1.4°C)	RETURN AIR TEMPERATURE CALIBRATION Allows for the operator to adjust for an out of calibration return air temperature (RA) sensor
	RA H CAL	0% RH	±10% RH	RETURN AIR HUMIDITY CALIBRATION Allows for the operator to adjust for an out of calibration return air enthalpy sensor
	DA T CAL	0.0 °F (or °C)	±2.5°F (±1.4°C)	DISCHARGE AIR TEMPERATURE CALIBRATION Allows for the operator to adjust for an out of calibration discharge air temperature (DAT) sensor
	2SP FAN DELAY	5 minutes	0 to 20 minutes in 1 min. increments.	TIME DELAY ON SECOND STAGE ECONOMIZING While in the Economizing mode, this is the delay between thermostat Y2 call and Y1-O output to mechanical cooling stage, to allow high speed fan operation to attempt to cool space first.
CHECKOUT <sup>f</sup>	DAMPER VMIN-HS	n/a	n/a	Positions damper to VMIN position.
	DAMPER VMAX-HS (LS)	n/a	n/a	Positions damper to VMAX position. With 2-speed fan units the damper will position to VMAX low speed fan.
	DAMPER OPEN	n/a	n/a	Positions damper to the full open position. Exhaust fan contacts enable during the DAMPER OPEN test. Make sure you pause in this mode to allow for exhaust contacts to energize due to the delay in the system.
	DAMPER CLOSE	n/a	n/a	Positions damper to the fully closed position.
	CONNECT Y1-O	n/a	n/a	Closes the Y1-O relay (Y1-O).
	CONNECT Y2-O	n/a	n/a	Closes the Y2-O relay (Y2-O).
	CONNECT AUX1-O	n/a	n/a	Energizes the AUX1-O output. If AUX1-O setting is: • NONE – no action taken • ERV – 24 Vac out. Turns on or signals an ERV that the conditions are not good for economizing but are good for ERV operation. <sup>d</sup> • SYS – 24 Vac out. Issues a system alarm.
CONNECT EXH1	n/a	n/a	Closes the power exhaust fan 1 relay (EXH1)	

TABLE 6. MENU STRUCTURE<sup>a</sup> (cont.)

MENU	PARAMETER	PARAMETER DEFAULT VALUE	PARAMETER RANGE and INCREMENT	NOTES
CHECKOUT <sup>f</sup>	DAMPER CLOSE	n/a	n/a	Positions damper to the fully closed position.
	CONNECT Y1-O	n/a	n/a	Closes the Y1-O relay (Y1-O).
	CONNECT Y2-O	n/a	n/a	Closes the Y2-O relay (Y2-O).
	CONNECT AUX1-O	n/a	n/a	Energizes the AUX1-O output. If AUX1-O setting is: <ul style="list-style-type: none"> <li>• NONE – no action taken</li> <li>• ERV – 24 Vac out. Turns on or signals an ERV that the conditions are not good for economizing but are good for ERV operation.<sup>d</sup></li> <li>• SYS – 24 Vac out. Issues a system alarm.</li> </ul>
	CONNECT EXH1	n/a	n/a	Closes the power exhaust fan 1 relay (EXH1)
ALARMS ( )	MA T SENS ERR	n/a	n/a	Alarms display <u>only</u> when they are active. The menu title 'ALARMS ( )' includes the number of active alarms in parenthesis ( ).
	CO <sub>2</sub> SENS ERR	n/a	n/a	
	OA T SENS ERR	n/a	n/a	
	DA ENZTHL ERR	n/a	n/a	
	SYS ALARM	n/a	n/a	When AUX1-O is set to SYS and there is any alarm (e.g., failed sensors, etc.), the AUX1-O terminal has 24 Vac out.
	ACT UNDER V	n/a	n/a	Voltage received by Actuator is below expected range
	ACT OVER V	n/a	n/a	Voltage received by Actuator is above expected range
	ACT STALLED	n/a	n/a	Actuator stopped before achieving commanded position

<sup>a</sup> Table 6 illustrates the complete hierarchy. Your menu parameters may be different depending on your configuration. For example if you do not have a DCV (CO<sub>2</sub>) sensor, then none of the DCV parameters appear.

<sup>b</sup> When values are displayed, pressing and holding the ▲ or ▼ button causes the display to automatically increment.

<sup>c</sup> n/a = not applicable

<sup>d</sup> ERV Operation: When in Cooling mode AND the conditions are NOT OK for economizing - the ERV terminal will be energized. In the Heating mode the ERV terminal will be energized when the OA is below the ERV OAT setpoint in the setpoint menu.

<sup>e</sup> When used with Honeywell communicating actuator the damper out is reported in percentage open versus Vdc.

<sup>f</sup> After 10 minutes without a command or mode change, the controller will change to normal operation.

<sup>g</sup> When using the C7632 (or any 0-10 Vdc CO<sub>2</sub> sensor) with the Jade you will need to set the CO<sub>2</sub>ZERO to 400 ppm and the CO<sub>2</sub>SPAN to 1600 ppm in the ADVANCED SETUP menu.



# WIRING DIAGRAMS - 7.5-12.5 TON WIRING DIAGRAM

**WARNING**

HIGH VOLTAGE!  
DISCONNECT ALL POWER BEFORE SERVICING OR INSTALLING THIS UNIT. MULTIPLE POWER SOURCES MAY BE PRESENT. FAILURE TO DO SO MAY CAUSE PROPERTY DAMAGE, PERSONAL INJURY OR DEATH.

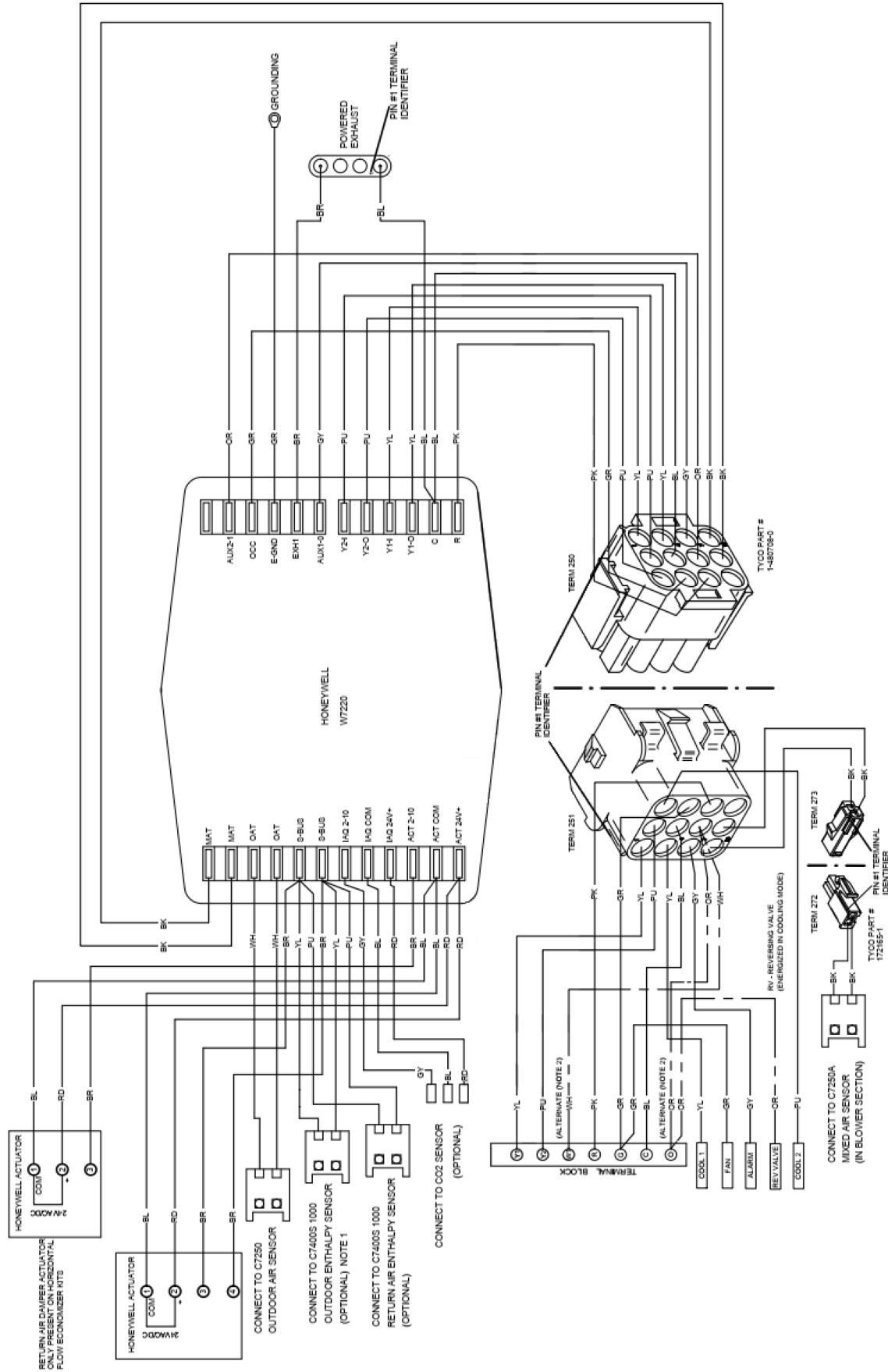

- NOTES:
1. OUTDOOR ENTHALPY SENSOR REPLACES DRY BULB OUTDOOR AIR SENSOR (SAME MOUNTING LOCATION). UNPLUG DRY BULB SENSOR FROM OAT. PLUS IN OUTDOOR ENTHALPY SENSOR INTO LABELED HARNESS AT S-BUS.
  2. "WH" FOR AC AND GAS UNITS, "O" FOR HEAT PUMP UNITS ONLY.

Wiring is subject to change. Always refer to the unit wiring diagram and accessory wiring diagram booklet for the most up-to-date wiring.

# DDC ECONOMIZER WIRING DIAGRAM



**WARNING**

HIGH VOLTAGE!  
DISCONNECT ALL POWER BEFORE SERVICING OR INSTALLING THIS UNIT. MULTIPLE POWER SOURCES MAY BE PRESENT. FAILURE TO DO SO MAY CAUSE PROPERTY DAMAGE, PERSONAL INJURY OR DEATH.

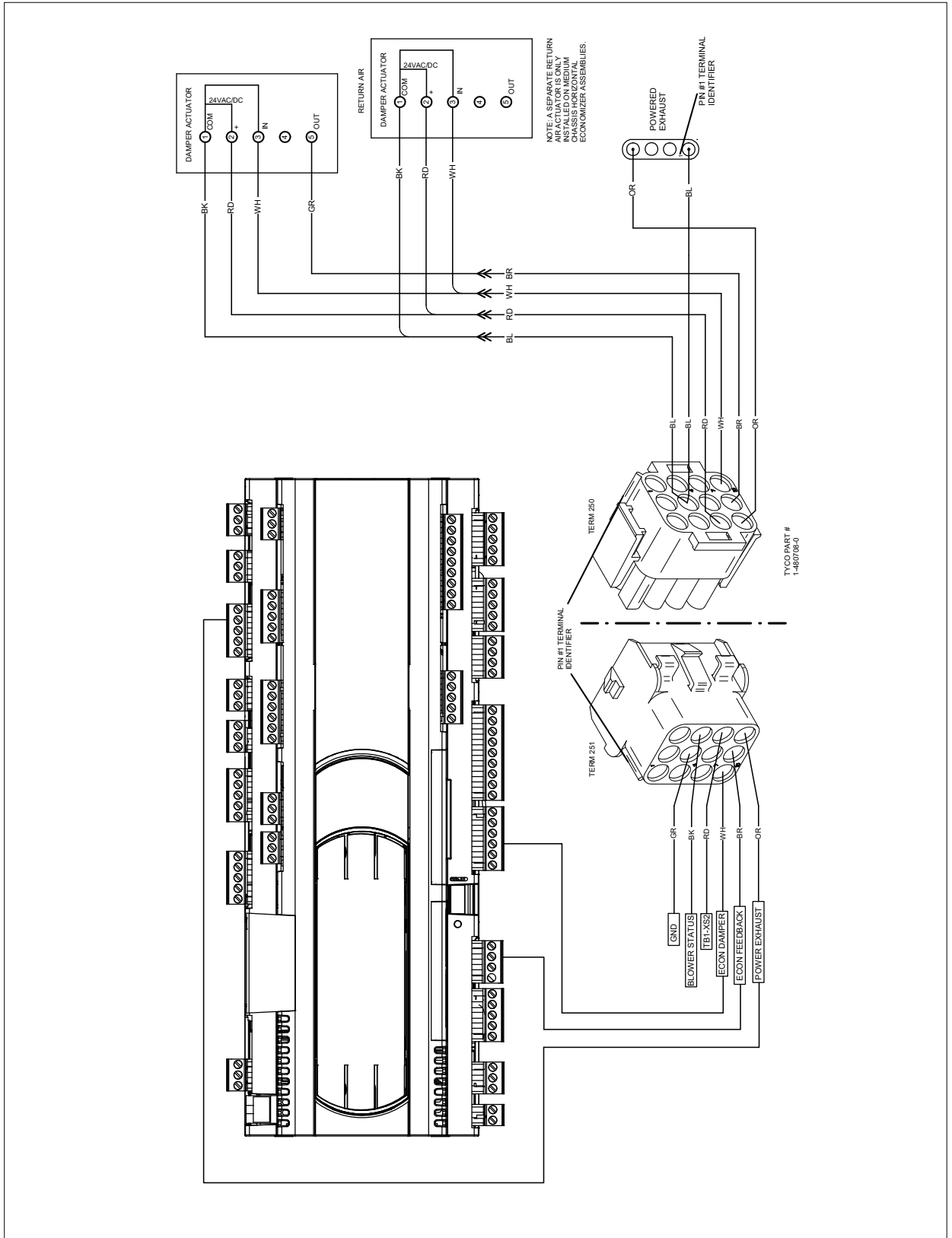

Wiring is subject to change. Always refer to the unit wiring diagram and accessory wiring diagram booklet for the most up-to-date wiring.

# DVH ECONOMIZER WIRING DIAGRAM



**WARNING**

**HIGH VOLTAGE!**  
 DISCONNECT ALL POWER BEFORE SERVICING OR INSTALLING THIS UNIT. MULTIPLE POWER SOURCES MAY BE PRESENT. FAILURE TO DO SO MAY CAUSE PROPERTY DAMAGE, PERSONAL INJURY OR DEATH.

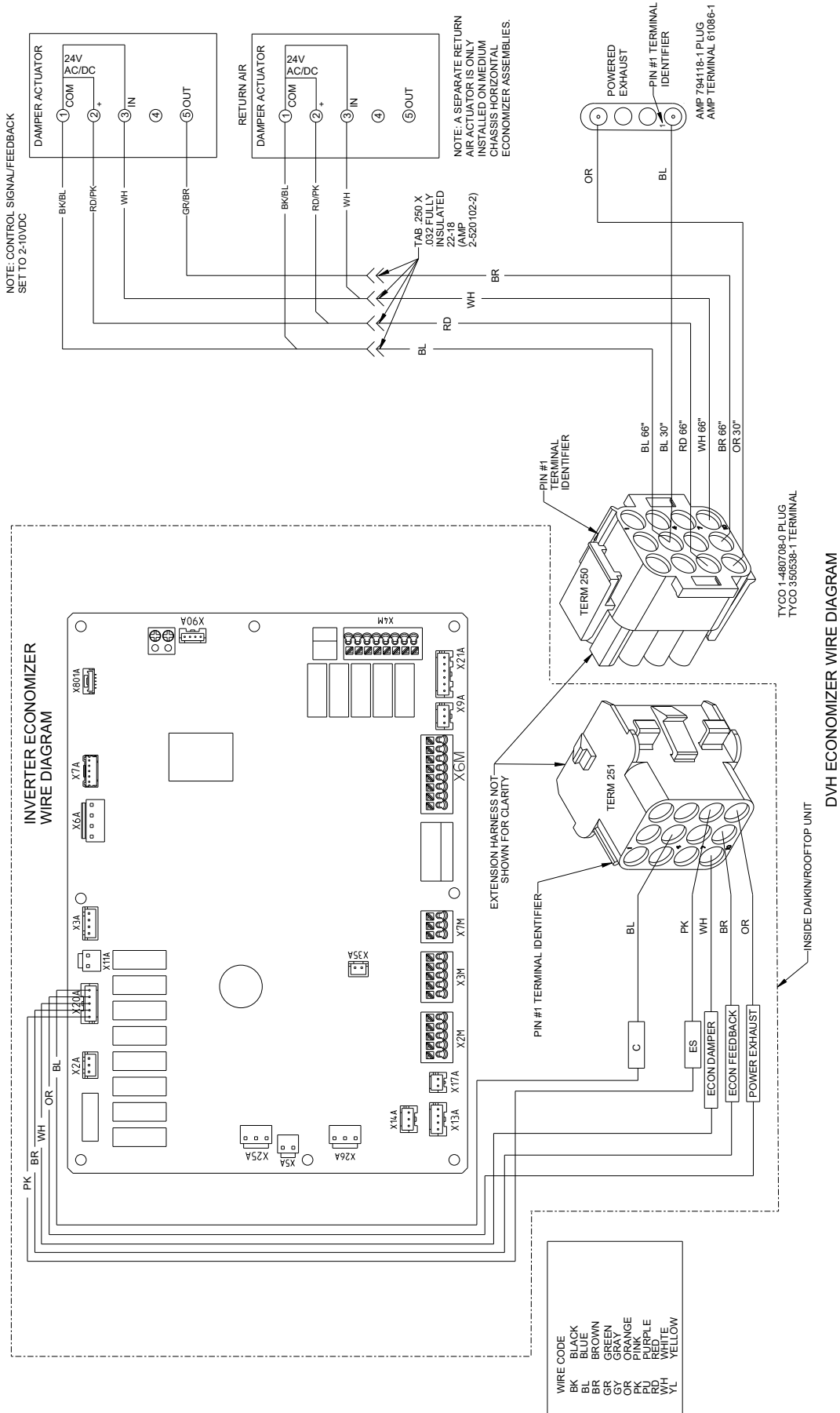

Wiring is subject to change. Always refer to the unit wiring diagram and accessory wiring diagram booklet for the most up-to-date wiring.

**THIS PAGE IS LEFT INTENTIONALLY BLANK.**

**THIS PAGE IS LEFT INTENTIONALLY BLANK.**

**THIS PAGE IS LEFT INTENTIONALLY BLANK.**

**CUSTOMER FEEDBACK**

Daikin is very interested in all product comments.

Please fill out the feedback form on the following link:

<https://daikincomfort.com/contact-us>

You can also scan the QR code on the right to be directed to the feedback page.



NOTE: SPECIFICATIONS AND PERFORMANCE DATA LISTED HEREIN ARE SUBJECT TO CHANGE WITHOUT NOTICE.

© 2019-2021, 2025 Daikin Comfort Technologies Manufacturing, Inc.  
19001 Kermier Rd., Waller, TX 77484  
[www.daikincomfort.com](http://www.daikincomfort.com)