

NATURAL GAS TO LP CONVERSION KITS (FOR 3 - 12.5 TON) LIGHT COMMERCIAL ROOFTOP UNITS INSTALLATION INSTRUCTIONS

© 2019-2021, 2024
DAIKIN COMFORT TECHNOLOGIES MANUFACTURING, L.P.
19001 Kermier Rd., Waller, TX 77484
www.daikincomfort.com
P/N: IOD-7088E Date: November 2024

SAFETY CONSIDERATIONS

The following symbols and labels are used throughout this manual to indicate immediate or potential safety hazards. It is the owner's and installer's responsibility to read and comply with all safety information and instructions accompanying these symbols. Failure to heed safety information increases the risk of personal injury, property damage, and/or product damage.



WARNING

ONLY PERSONNEL THAT HAVE BEEN TRAINED TO INSTALL, ADJUST, SERVICE OR REPAIR (HEREINAFTER, "SERVICE") THE EQUIPMENT SPECIFIED IN THIS MANUAL SHOULD SERVICE THE EQUIPMENT. THE MANUFACTURER WILL NOT BE RESPONSIBLE FOR ANY INJURY OR PROPERTY DAMAGE ARISING FROM IMPROPER SERVICE OR SERVICE PROCEDURES. IF YOU SERVICE THIS UNIT, YOU ASSUME RESPONSIBILITY FOR ANY INJURY OR PROPERTY DAMAGE WHICH MAY RESULT. IN ADDITION, IN JURISDICTIONS THAT REQUIRE ONE OR MORE LICENSES TO SERVICE THE EQUIPMENT SPECIFIED IN THIS MANUAL, ONLY LICENSED PERSONNEL SHOULD SERVICE THE EQUIPMENT. IMPROPER INSTALLATION, ADJUSTMENT, SERVICING OR REPAIR OF THE EQUIPMENT SPECIFIED IN THIS MANUAL, OR ATTEMPTING TO INSTALL, ADJUST, SERVICE OR REPAIR THE EQUIPMENT SPECIFIED IN THIS MANUAL WITHOUT PROPER TRAINING MAY RESULT IN PRODUCT DAMAGE, PROPERTY DAMAGE, PERSONAL INJURY OR DEATH.



WARNING

HIGH VOLTAGE!
DISCONNECT ALL POWER BEFORE SERVICING OR INSTALLING THIS UNIT. MULTIPLE POWER SOURCES MAY BE PRESENT. FAILURE TO DO SO MAY CAUSE PROPERTY DAMAGE, PERSONAL INJURY OR DEATH.



RECOGNIZE THIS SYMBOL AS A SAFETY PRECAUTION.

ATTENTION INSTALLING PERSONNEL

As a professional installer, you have an obligation to know the product better than the customer. This includes all safety precautions and related items.

Prior to actual installation, thoroughly familiarize yourself with this Instruction Manual. Pay special attention to all safety warnings. Often during installation or repair, it is possible to place yourself in a position which is more hazardous than when the unit is in operation.

Remember, it is your responsibility to install the product safely and to know it well enough to be able to instruct a customer in its safe use.

Safety is a matter of common sense...a matter of thinking before acting. Most dealers have a list of specific good safety practices...follow them.

The precautions listed in this Installation Manual are intended as supplemental to existing practices. However, if there is a direct conflict between existing practices and the content of this manual, the precautions listed here take precedence.

DESCRIPTION

This Natural Gas to LP (liquid petroleum) gas conversion kit allows White-Rodgers gas valve 36G54 (0151F00000P) or gas valve 36H54 (0151L00000) to be used in LP gas applications.

Use the following parts lists to ensure that all the parts are present and in an undamaged condition. Please ensure that you are using the correct LPHE kit with the correct orifices. Drill size is marked on the orifice side or face.

IF ANY DOUBT EXISTS ABOUT THE CONDITIONS OF ANY COMPONENT WITHIN THIS KIT, DO NOT USE THIS KIT AND CONTACT YOUR SUPPLIER FOR A NEW KIT.



KIT CONTENTS (ALL)

Parts List LPHE-036072 (3-6 Ton Models)		
Part Number	Description	Qty.
0163F00000P	White-Rodgers LP Conversion Kit F92-1008	1
B14933151	Conversion Label	1
0151K00000S	36G54 Pressure Check Kit	1
IOD-7088C	Installation Instructions	1
0163L00245	#54 Spud Orifice Assembly (6 PC's)	1
B4089955	#55 Spud Orifice Assembly (6 PC's)	1
B2589908	#56 Spud Orifice Assembly (6 PC's)	1
0140M00517	Warning Label	1

Parts List LPHE-090150 (7.5-12.5 Ton Models)		
Part Number	Description	Qty.
0163F00000P	White-Rodgers LP Conversion Kit F92-1008	1
B14933151	Conversion Label	1
IOD-7088C	Installation Instructions	1
0163L00241	#50 Spud Orifice Assembly (7 PC's)	1
0163L00242	#51 Spud Orifice Assembly (7 PC's)	1
0163L00243	#52 Spud Orifice Assembly (7 PC's)	1
0163L00244	#53 Spud Orifice Assembly (7 PC's)	1
0163L00245	#54 Spud Orifice Assembly (7 PC's)	1
0140M00517	Warning Label	1

NOTE: SEE LP ORIFICE SELECTION CHART IN THESE INSTRUCTIONS.

With the exception of the natural gas burner orifices, all of the fasteners and other components removed to perform this conversion are to be reused. Any component found to be damaged due to this conversion must be replaced with factory authorized replacement parts before this furnace can be put into operation.

This furnace is equipped for two-stage heating operation. The gas valve manifold pressure must be set for LP with first stage operating at 6" +/-0.3" WC manifold pressure and the second stage must be set at 10"+0.3" WC manifold pressure. The accuracy of these pressures must be checked as shown in steps 23 and 24 of these instructions.

IMPORTANT INFORMATION

DANGER
PELIGRO

CARBON MONOXIDE POISONING HAZARD

Special Warning for Installation of Furnace or Air Handling Units in Enclosed Areas such as Garages, Utility Rooms or Parking Areas

Carbon monoxide producing devices (such as automobiles, space heater, gas water heater, etc.) should not be operated in enclosed areas such as unventilated garages, utility rooms or parking areas because of the danger of carbon monoxide (CO) poisoning resulting from the exhaust emissions. If a furnace or air handler is installed in an enclosed area such as a garage, utility room or parking area and a carbon monoxide producing device is operated therein, there must be adequate, direct outside ventilation.

This ventilation is necessary to avoid the danger of CO poisoning which can occur if a carbon monoxide producing device continues to operate in the enclosed area. Carbon monoxide emissions can be (re)circulated throughout the structure if the furnace or air handler is operating in any mode.

CO can cause serious illness including permanent brain damage or death.

B10259-216

RIESGO DE INTOXICACIÓN POR MONÓXIDO DE CARBONO

Advertencia especial para la instalación de calentadores ó manejadoras de aire en áreas cerradas como estacionamientos ó cuartos de servicio.

Los equipos ó aparatos que producen monóxido de carbono (tal como automóvil, calentador de gas, calentador de agua por medio de gas, etc) no deben ser operados en áreas cerradas debido al riesgo de envenenamiento por monóxido de carbono (CO) que resulta de las emisiones de gases de combustión. Si el equipo ó aparato se opera en dichas áreas, debe existir una adecuada ventilación directa al exterior.

Esta ventilación es necesaria para evitar el peligro de envenenamiento por CO, que puede ocurrir si un dispositivo que produce monóxido de carbono sigue operando en el lugar cerrado.

Las emisiones de monóxido de carbono pueden circular a través del aparato cuando se opera en cualquier modo.

El monóxido de carbono puede causar enfermedades severas como daño cerebral permanente ó muerte.

B10259-216

RISQUE D'EMPOISONNEMENT AU MONOXYDE DE CARBONE

Avertissement special au sujet de l'installation d'appareils de chauffage ou de traitement d'air dans des endroits clos, tels les garages, les locaux d'entretien et les stationnements.

Evitez de mettre en marche les appareils produisant du monoxyde de carbone (tels que les automobile, les appareils de chauffage autonome, etc.) dans des endroits non ventilés tels que les d'empoisonnement au monoxyde de carbone. Si vous devez faire fonctionner ces appareils dans un endroit clos, assurez-vous qu'il y ait une ventilation directe provenant de l'exterieur.

Cette ventilation est nécessaire pour éviter le danger d'intoxication au CO pouvant survenir si un appareil produisant du monoxyde de carbone continue de fonctionner au sein de la zone confinée.

Les émissions de monoxyde de carbone peuvent être recirculées dans les endroits clos, si l'appareil de chauffage ou de traitement d'air sont en marche.

Le monoxyde de carbone peut causer des maladies graves telles que des dommages permanents au cerveau et même la mort.

B10259-216



WARNING

CARBON MONOXIDE (CO) CAN CAUSE SEVERE PERSONAL INJURY OR DEATH.



CAUTION

LABEL ALL WIRES PRIOR TO DISCONNECTION WHEN SERVICING CONTROLS. WIRING ERRORS CAN CAUSE IMPROPER AND DANGEROUS OPERATION. VERIFY PROPER OPERATION AFTER SERVICING.

NOTE: Do NOT USE POWER TOOLS FOR ANY ADJUSTMENTS ON GAS VALVES.



WARNING

TO AVOID THE POSSIBILITY OF EXPLOSION OR FIRE, NEVER USE A MATCH OR OPEN FLAME TO TEST FOR LEAKS.

Required Tools and Supplies for Kit Installation

QTY	DESCRIPTION
2	Pipe wrenches, properly sized to accommodate the gas piping and connectors
1	7/16" box wrench or socket wrench
1	5/16" nut driver
1	1/4" flat blade screwdriver
1	3/32" Allen wrench (for 36G valve)
1	Manometer to read inlet and outlet pressure of the gas valve (minimum range: 0"-20" WC)
	Pipe joint compound that is approved for use with LP gas
	Gas leak detection solution like a soap and water solution. Always wipe the solution from the joints when testing is completed.

Prior to performing this conversion, refer to the latest edition of National Fuel Gas Code (NFPA 54 / ANSI Z223.1) or in Canada, CSA B149.1 to ensure that the installation is in compliance with those and all local codes.



WARNING

THIS LP (LIQUID PETROLEUM) CONVERSION KIT MUST BE INSTALLED BY A QUALIFIED SERVICE PERSON OR AGENCY IN ACCORDANCE WITH THE MANUFACTURER'S INSTRUCTIONS AND ALL APPLICATION CODES AND REQUIREMENTS OF THE AUTHORITY HAVING JURISDICTION. FAILURE TO FOLLOW THESE INSTRUCTIONS EXPLICITLY MAY CAUSE A FIRE, EXPLOSION OR THE PRODUCTION OF CARBON MONOXIDE (CO), WHICH CAN CAUSE PROPERTY DAMAGE, PERSONAL INJURY OR DEATH. THE QUALIFIED PERSON PERFORMING THIS CONVERSION ASSUMES THE RESPONSIBILITY FOR THE PROPER CONVERSION OF THE APPLIANCE.



CAUTION

TO PREVENT UNSATISFACTORY FURNACE OPERATION, THE PROPER GAS CONVERSION KIT MUST BE USED FOR THE GAS VALVE. USE THE WHITE-RODGERS SPRING KIT ONLY WITH THE WHITE-RODGERS GAS VALVE.



WARNING

ALL METAL SCREENS MUST BE REMOVED FROM THE HEAT EXCHANGER TUBES WHEN USING PROPANE GAS. FAILURE TO COMPLY WITH THIS REQUIREMENT WILL ALSO VOID WARRANTY COVERAGE.



CAUTION

SHUT OFF GAS SUPPLY FIRST, THEN DISCONNECT THE ELECTRICAL SUPPLY BEFORE PROCEEDING WITH THE CONVERSION.

1. Turn off the gas supply to the furnace.
2. Turn off the electrical power to the furnace.
3. Remove the furnace control access panel.
4. On 3 to 6 ton models remove NOx screens, see Figure 1. There are no screens on other models.
5. Separate the gas supply union and remove associated downstream piping.
6. Always use a backup wrench when removing or replacing piping to avoid any undue strains or rotation of controls.
7. Remove wires from gas valve, igniter, flame sensor and rollout switch.
8. Remove 4 sheet metal screws that fasten the manifold/gas valve assembly to the burner box. See Figure 2.
9. Visually inspect orifices for damage and drill size (marked on face or side) before installation. Using the 1/16" wrench, remove all existing natural gas orifices and replace with the appropriate marked LP gas orifices contained in this kit. Tighten the orifices to prevent gas leaks, but do not overtighten. A minimum 3-1/2 thread engagement is required. Retain the natural gas orifices for future reconversion.

For 36G valve: Use pressure check kit p/n 0151K00000S and its instructions included in this kit.

- Using a 3/32" Allen wrench included in pressure check kit, loosen the inlet pressure tap screw one (1) turn only (DO NOT REMOVE).
- Attach 5/16" hose to the inlet pressure boss of the valve. Hose should overlap boss 3/8 inch.
- Connect the 5/16" side of the included connector to the hose on the inlet boss and 1/4" side of the connector to the manometer hose. The manometer must have a scale range of at least 0" to 20" WC.

10. Remove both regulator cover screws on the gas valve. See Figure 3.
11. Using a ¼" flat blade screwdriver, remove both regulator adjustment screws (beneath the cover screws).
12. Remove the Natural Gas regulator springs (color-coded silver/plain) from regulator sleeves and retain with the Natural Gas orifices for future reconversion.
13. Insert the LP regulator springs (provided in the conversion kit and color-coded white) into the regulator sleeves.
14. Replace the High regulator adjustment screw and adjust approximately 12 turns to the bottom stop. Use the instructions following step 22 to check that the manifold pressure falls within the desired range, and adjust if needed.
15. Replace the Low regulator adjustment screw and adjust approximately 8 turns to bottom. Use the instructions following step 22 to check that the manifold pressure falls within the desired range, and adjust if needed.
16. Reinstall the manifold/gas valve assembly into the appliance. Rewire gas valve, igniter, flame sensor and rollout switch per wiring diagram.
17. Apply a liberal amount of pipe joint compound to the threads and reassemble the piping previously removed. Use a backup wrench to avoid any undue strains or rotation of controls.

- After the inlet (supply) pressures have been adjusted to the correct setting follow the below steps to verify and adjust the manifold pressure.

FOR 36G AND 36H VALVE:

- Turn off gas and electrical supply to the unit
- Remove the manometer hose from the inlet pressure tap boss and tighten the inlet pressure tap screw using the ⅜" Allen wrench.
- Loosen the outlet pressure tap screw one (1) turn only (DO NOT REMOVE).
- Attach ⅝" hose with the connector and manometer to the outlet pressure boss of the valve. Hose should overlap boss ⅜ inch.

23. With the furnace operating in its low-fire (W1) condition, the manifold pressure should be 6 ± 0.3 " WC. If necessary, this pressure can be adjusted using the gas valve low regulator adjustment screw. Turn clockwise to increase pressure and counterclockwise to decrease manifold pressure.
24. Readjust the room thermostat to obtain a second stage call for heat (W2). The manifold pressure for the W2 condition should be 10 ± 0.3 " WC. If necessary, this pressure can be adjusted using the gas valve high regulator adjustment screw. Turn clockwise to increase pressure and counterclockwise to decrease manifold pressure.

IMPORTANT NOTE: FOR HIGH ALTITUDE DERATES, REFER TO THE LATEST EDITION OF THE NATIONAL FUEL GAS CODE (NFPA54/ANSIZ223.1).

25. Using the room thermostat to cycle the unit, observe a minimum of three (3) smooth ignition cycles.

For 36G and 36H valve: Turn off gas and electrical supply to the unit, remove the manometer hose from the pressure tap boss and tighten the outlet pressure tap screw.



WARNING

TO PREVENT THE POSSIBILITY OF GAS LEAKS, THE PIPE JOINT COMPOUND MUST BE RESISTANT TO LP GAS.

18. Turn on the gas supply.
19. Using a soap and water solution, check for leaks around the gas valve/manifold connection.
20. Turn on the electrical supply.
21. Adjust the room thermostat to obtain a first stage (W1 only) burner operation – Low fire.



WARNING

NEVER USE AN OPEN FLAME TO CHECK FOR GAS LEAKS.

22. Using a soap and water solution, check for leaks around the burner orifices. Repair any leaks before continuing.

NOTE: ANY OTHER GAS-FIRED EQUIPMENT SHOULD BE ON BEFORE ANY ADJUSTMENTS ARE MADE. AFTER THE FURNACE HAS BEEN IN OPERATION FOR 15 MINUTES, ADJUST THE GAS SUPPLY PRESSURE (NOT MANIFOLD PRESSURE) TO OBTAIN A RANGE BETWEEN 11" AND 14" WC IF THE GAS INLET PRESSURE FALLS OUTSIDE OF THIS RANGE, THEN MAKE THE NECESSARY LP SERVICE REGULATOR(S) ADJUSTMENTS; CHECK PIPING SIZE, ETC., AND/OR CONSULT WITH LP PROVIDER.



WARNING

ATTACH THE WARNING LABEL PROVIDED IN THE KIT TO THE GAS VALVE WHERE IT CAN BE READILY SEEN. ATTACH THE SMALL, ROUND LP LABELS TO THE TOP OF THE REGULATOR COVER SCREWS.

26. Replace both regulator cover screws on the regulator sleeve.

IMPORTANT NOTE: APPLY THE CONVERSION LABEL (B14933151) PROVIDED WITH THE CONVERSION KIT. THIS LABEL MUST BE ATTACHED ADJACENT TO THE RATING PLATE.

27. Reinstall the access panels.
28. Turn on the gas and electrical supply.
29. Reset all other appliances so they function normally.

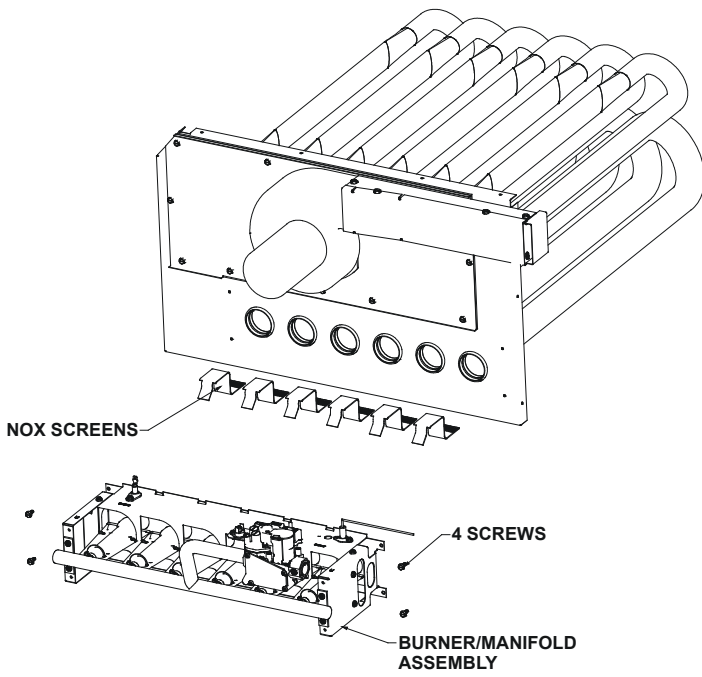

Typical NOx Screen Removal for 3 to 6 Ton Models
Figure 1

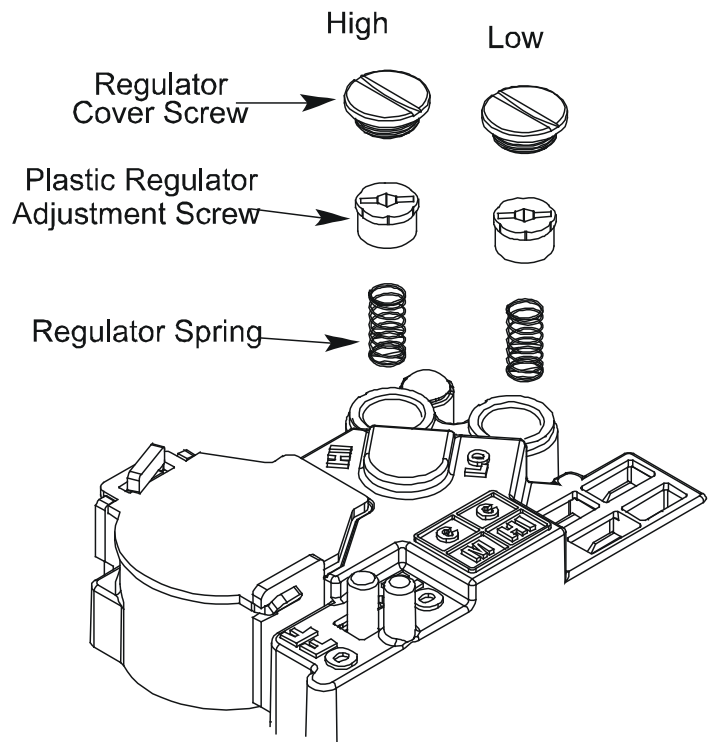

White-Rodgers 36G54 Springs and Regulator Screws
Figure 3

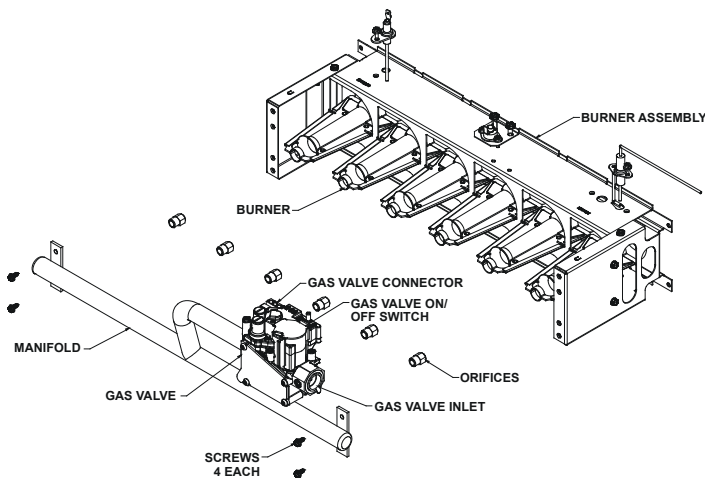

Burner Orifices Replacement
Figure 2

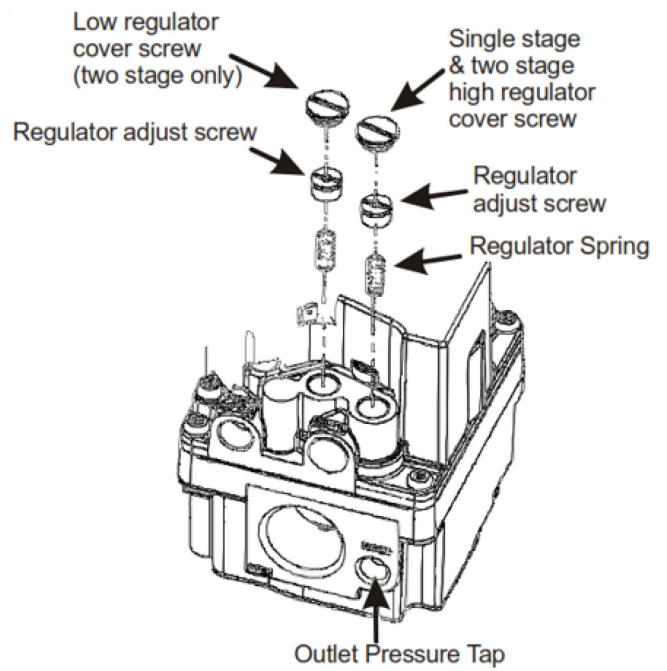

White-Rodgers 36H54 Springs and Regulator Screws
Figure 4

DBG/DFG/DSG LP ORIFICE SELECTION CHART

Ton	Model	High Fire Rate BTU/HR	Number of Burners	N.G. Orifice Drill #	L.P. Orifice Drill #
3	DBG/DFG/DSG036	45,000	2	43	55
		70,000	3	43	55
		90,000	5	45	56
4	DBG/DFG/DSG048	70,000	3	43	55
		90,000	4	43	55
		115,000	5	43	55
5	DBG/DFG/DSG060	90,000	4	43	55
		115,000	5	43	55
		140,000	6	43	55
6	DBG/DFG/DSG072	90,000	4	43	55
		115,000	5	43	55
		140,000	6	43	55
7.5	DBG090	210,000	7	37	53
8.5	DBG102	210,000	7	37	53
10	DBG120	210,000	7	37	53
12.5	DBG150	210,000	7	37	53

DRG/DFG/DHG/DSG LP ORIFICE SELECTION CHART

Ton	Model	High Fire Rate BTU/HR	Number of Burners	N.G. Orifice Drill #	L.P. Orifice Drill #
3	DRG/DHG036	45,000	2	43	55
		70,000	3	43	55
		115,000	6	45	56
4	DRG/DHG048	70,000	3	43	55
		115,000	5	43	55
		140,000	6	43	55
5	DRG/DHG060	70,000	3	43	55
		115,000	5	43	55
		140,000	6	43	55
6	DRG/DHG072	70,000	3	43	55
		125,000	5	41	54
		150,000	6	41	54
7.5	DFG/DRG/DSG/DHG090	130,000	5	41	54
		180,000	6	37	53
		225,000	7	36	52
8.5	DFG/DRG/DSG/DHG102	130,000	5	41	54
		180,000	6	37	53
		225,000	7	36	52
10	DFG/DRG/DSG/DHG120	130,000	4	41	54
		180,000	5	37	53
		240,000	7	34	51
12.5	DFG/DRG/DSG/DHG150	130,000	4	41	54
		180,000	5	37	53
		240,000	7	34	51

NOTE: LP HIGH FIRE RATE IS REDUCED 10% THAT OF NATURAL GAS.

THIS PAGE IS INTENTIONALLY LEFT BLANK

CUSTOMER FEEDBACK

Daikin is very interested in all product comments.

Please fill out the feedback form on the following link:

<https://daikincomfort.com/contact-us>

You can also scan the QR code on the right to be directed to the feedback page.



NOTE: SPECIFICATIONS AND PERFORMANCE DATA LISTED HEREIN ARE SUBJECT TO CHANGE WITHOUT NOTICE

Quality Makes the Difference!

All of our systems are designed and manufactured with the same high quality standards regardless of size or efficiency. We have designed these units to significantly reduce the most frequent causes of product failure. They are simple to service and forgiving to operate. We use quality materials and components. Finally, every unit is run tested before it leaves the factory.

That's why we know. . . **There's No Better Quality.**

Our continuing commitment to quality products may mean a change in specifications without notice.

© 2019 - 2021, 2024 **DAIKIN COMFORT TECHNOLOGIES MANUFACTURING, L.P.**

19001 Kermier Rd., Waller, TX 77484

www.daikincomfort.com