

LOW AMBIENT CONTROL KIT (LACK) INSTALLATION INSTRUCTIONS

© 2024 **DAIKIN COMFORT TECHNOLOGIES MANUFACTURING, L.P.**

19001 Kermier Rd., Waller, TX 77484

www.daikincomfort.com

P/N: IOD-7140E Date: December 2024



WARNING

ONLY PERSONNEL THAT HAVE BEEN TRAINED TO INSTALL, ADJUST, SERVICE, MAINTENANCE OR REPAIR (HEREINAFTER, "SERVICE") THE EQUIPMENT SPECIFIED IN THIS MANUAL SHOULD SERVICE THE EQUIPMENT.

THIS EQUIPMENT IS NOT INTENDED FOR USE BY PERSONS (INCLUDING CHILDREN) WITH REDUCED PHYSICAL, SENSORY OR MENTAL CAPABILITIES, OR LACK OF EXPERIENCE AND KNOWLEDGE, UNLESS THEY HAVE BEEN GIVEN SUPERVISION OR INSTRUCTION CONCERNING USE OF THE APPLIANCE BY A PERSON RESPONSIBLE FOR THEIR SAFETY.

CHILDREN SHOULD BE SUPERVISED TO ENSURE THAT THEY DO NOT PLAY WITH THE EQUIPMENT.

THE MANUFACTURER WILL NOT BE RESPONSIBLE FOR ANY INJURY OR PROPERTY DAMAGE ARISING FROM IMPROPER SUPERVISION, SERVICE OR SERVICE PROCEDURES. IF YOU SERVICE THIS UNIT, YOU ASSUME RESPONSIBILITY FOR ANY INJURY OR PROPERTY DAMAGE WHICH MAY RESULT. IN ADDITION, IN JURISDICTIONS THAT REQUIRE ONE OR MORE LICENSES TO SERVICE THE EQUIPMENT SPECIFIED IN THIS MANUAL, ONLY LICENSED PERSONNEL SHOULD SERVICE THE EQUIPMENT. IMPROPER SUPERVISION, INSTALLATION, ADJUSTMENT, SERVICING, MAINTENANCE OR REPAIR OF THE EQUIPMENT SPECIFIED IN THIS MANUAL, OR ATTEMPTING TO INSTALL, ADJUST, SERVICE OR REPAIR THE EQUIPMENT SPECIFIED IN THIS MANUAL WITHOUT PROPER SUPERVISION OR TRAINING MAY RESULT IN PRODUCT DAMAGE, PROPERTY DAMAGE, PERSONAL INJURY OR DEATH.



WARNING

Do NOT BYPASS SAFETY DEVICES.

DESCRIPTION

A properly installed Low Ambient Control Kit (LACK) expands the working cooling operation of the equipped unit to 0°F ambient. This is accomplished by cycling the power to the condenser fan motor(s) to regulate compressor discharge pressure.

The kits utilize a combination of pressure switch(es) (285 psi open, 435 psi close) and relay(s) to cycle the condenser fan motor(s) when needed. An ambient temperature switch (55°F open, 65°F close) is also included to lock out cycling at temperatures that do not require it. All supplemental mounting hardware, wiring, and fittings are included with the kits.

TABLE OF CONTENTS

DESCRIPTION	1
CONSIDERATIONS	2
KIT APPLICATIONS	2
KIT CONTENTS.....	3
3-6 TON INSTALLATION	5
7.5-12.5 TON INSTALLATION (FOR DR AND DB MODELS).....	7
7.5-12.5 TON INSTALLATION (FOR DF, DS, AND DH MODELS)	10
15 - 25 TON INSTALLATION	13
WIRING LEGEND.....	16
LACKSM011 WIRING	17
LACKSM012 WIRING	18
LACKSM013 WIRING	19
LACKSM014 WIRING	20
LACKSM015 WIRING	21
LACKSM016 WIRING	22
7.5-12.5 TON PRESSURE SWITCH ROUTING	23
LACKMD012 & LACKMD016 WIRING	27
LACKMD013 & LACKMD017 WIRING	28
LACKMD020 WIRING (DFC/DFG AND DSC/DSG)	29
LACKMD020 WIRING (DFH AND DSH)	30
LACKMD020 WIRING (DHC/DHG090, DHC/DHG102, DHC/DHG120).....	31
LACKMD020 WIRING (DHC/DHG150)	32
LACKMD021 WIRING (DBC/DBG)	33
LACKMD021 WIRING (DBH090, DBH102, DBH120) ..	34
LACKMD021 WIRING (DBH150)	35
LACKLG012 WIRING.....	36
LACKLG013 WIRING.....	38
LACKLG014 WIRING.....	40



CONSIDERATIONS

ASHRAE 90.1-2016 requires units with a cooling capacity of 54,000 BTU/H or greater to be equipped with an economizer. A properly functioning economizer significantly reduces the annual cycle count on the LACK components. Ignoring this requirement could result in a shorter lifespan for these components.

It is recommended that units equipped with a LACK also be equipped with a crankcase heater. This can help reduce wear on the compressor specifically attributed to operation in low ambient conditions.

For installation areas where the ambient temperature can drop below 10°F, and cooling operation is required below 30°F, low-pressure Switch(es) have been included in the kit to replace the factory low-pressure switch(es). This is necessary because the factory installed low-pressure switch(es) will open if the unit is off and exposed to sub 10°F ambient for an extended period and will not reset until 30°F ambient. Disabling or replacing of the low-pressure switch(es) is not necessary outside of this specific application.

In installation areas where sustained winds are common during low ambient seasons, a device to deflect, check, or regulate flow through the condenser coil may be required for stable operation. The added airflow at low ambient temperatures can drive the operating conditions of the unit below the design envelope and cause malfunction, e.g., a frozen evaporator coil.

NOTE: THIS UNIT SHOULD BE INSTALLED IN A MANNER SO THAT IT IS NOT ACCESSIBLE TO THE PUBLIC.

KIT APPLICATIONS

3-6 TON MODELS	DDC?	LACKSM011	LACKSM012	LACKSM013	LACKSM014	LACKSM015	LACKSM016
DBC/DBG036	-	X					
DBC/DBG048	-	X					
DBC/DBG060	-	X					
DBC/DBG072	-	X					
DBH036	-				X		
DBH048	-				X		
DBH060	-				X		
DFC/DFG036	-	X					
DFC/DFG048	-	X					
DFC/DFG060	-	X					
DFC/DFG072	-	X					
DFH036	-				X		
DFH048	-				X		
DFH060	-				X		
DFH072	-				X		
DRC/DRG036	-	X					
DRC/DRG048	-	X					
DRC/DRG060	-		X				
DRC/DRG072	-	X					
DRH036	-				X		
DRH048	-					X	
DRH060	-					X	
DRH072	-				X		
DRC/DRG036	✓	X					
DRC/DRG048	✓	X					
DRC/DRG060	✓		X				
DRC/DRG072	✓	X					
DRH036	✓				X		
DRH048	✓						X
DRH060	✓						X
DRH072	✓				X		
DSC/DSG036	-	X					
DSC/DSG048	-	X					
DSC/DSG060	-	X					
DSC/DSG072	-	X					
DSH036	-				X		
DSH048	-				X		
DSH060	-				X		
DSH072	-				X		

7.5-12.5 TON MODELS	DDC?	LACKMD012	LACKMD013	LACKMD016	LACKMD017	LACKMD020	LACKMD021
DBC/DBG090	-						X
DBC/DBG102	-						X
DBC/DBG120	-						X
DBC/DBG150	-						X
DBH090	-						X
DBH102	-						X
DBH120	-						X
DBH150	-						X
DRC/DRG090	-	X					
DRC/DRG102	-	X					
DRC/DRG120	-	X					
DRC/DRG150	-		X				
DRC/DRG090	✓			X			
DRC/DRG102	✓			X			
DRC/DRG120	✓			X			
DRC/DRG150	✓				X		
DFC/DFG090	-					X	
DFC/DFG102	-					X	
DFC/DFG120	-					X	
DFC/DFG150	-					X	
DFH090	-					X	
DFH102	-					X	
DFH120	-					X	
DSC/DSG090	-					X	
DSC/DSG102	-					X	
DSC/DSG120	-					X	
DSC/DSG150	-					X	
DSH090	-					X	
DSH102	-					X	
DSH120	-					X	
DHC/DHG090	-					X	
DHC/DHG102	-					X	
DHC/DHG120	-					X	
DHC/DHG150	-					X	
DHC/DHG090	✓					X	
DHC/DHG102	✓					X	
DHC/DHG120	✓					X	
DHC/DHG150	✓					X	

15-25 TON MODELS	DDC?	LACKLG012	LACKLG013	LACKLG014
DBC/DBG180	-	SEE IOD-7130		
DBC/DBG240	-	SEE IOD-7130		
DBC/DBG300	-	SEE IOD-7021		
DBC/DBG180	✓	SEE IOD-7130		
DBC/DBG240	✓	SEE IOD-7130		
DBC/DBG300	✓	SEE IOD-7119		
DFC/DFG180	-			X
DFC/DFG240	-	X		
DFC/DFG300	-		X	
DFC/DFG180	✓			X
DFC/DFG240	✓	X		
DFC/DFG300	✓		X	
DSC/DSG180	-			X
DSC/DSG240	-	X		
DSC/DSG300	-		X	

KIT CONTENTS

3-6 TON PARTS	DESCRIPTION	LACKSM011	LACKSM012	LACKSM013	LACKSM014	LACKSM015	LACKSM016
0121L04533	LACKMOUNT	1	1	1	1	1	1
0121L04572	ACCESSORY MOUNT	1	1	1	1	1	1
M0221817	#10 X 1/2" SCREW	6	6	6	6	6	6
0161M00042	GUIDE CLIP	2	2	2	2	2	2
0130M00178	DPDT RELAY 24VAC	1	1	1	1	1	1
10135604	SPDT RELAY 24VAC	-	-	-	1	1	1
M0216716	#8 X 3/8" SCREW	2	2	2	4	4	4
0259L01942	WIRE HARNESS	1	-	-	1	-	-
0259L01943	WIRE HARNESS	-	1	-	-	1	-
0259L01968	WIRE HARNESS	-	-	1	-	-	1
0259L01938	WIRE HARNESS	1	1	1	-	-	-
0259L01939	WIRE HARNESS	-	-	-	1	1	-
0259L01970	WIRE HARNESS	-	-	-	-	-	1
0130L00282	TEMP SWITCH	1	1	1	1	1	1
0130L00279	PRESSURE SWITCH	1	1	1	1	1	1
W18203271271003	3" YELLOW WIRE	-	1	1	-	1	1
0111L00041	1/4" SWIVEL TEE	1	1	1	1	1	1
B1096102	CABLE TIE	3	3	3	3	3	3
0130M00733	OPTIONAL LOW PRESS. SWITCH	1	-	-	1	-	-

7.5-12.5 TON PARTS	DESCRIPTION	LACKMD012	LACKMD013	LACKMD016	LACKMD017	LACKMD020	LACKMD021
0121L04534	LACK MOUNT	1	1	-	-	-	1
0121L04057	VOLTAGE BARRIER	1	1	-	-	-	1
0121L04609	DDC LACK MOUNT	-	-	1	1	-	-
0121L03952	ACCESSORY MOUNT	-	-	1	1	-	-
M0221817	#10 X 1/2" SCREW	2	2	4	4	-	2
0161M00042	GUIDE CLIP	2	2	-	-	-	2
M0104102	GUIDE CLIP	-	-	2	2	-	-
0130M00178	DPDT RELAY 24VAC	2	2	2	2	3	3
M0216716	#8 X 3/8" SCREW	4	4	4	4	6	6
0259L01972	WIRE HARNESS	1	-	1	-	-	1
0259L01979	WIRE HARNESS	-	1	-	1	-	1
0259L01973	WIRE HARNESS	-	-	-	-	-	1
0259L01976	WIRE HARNESS	1	-	1	-	-	-
0259L01977	WIRE HARNESS	1	1	1	1	1	1
0259L01978	WIRE HARNESS	1	1	1	1	-	-
0259L01980	WIRE HARNESS	-	-	-	-	-	1
0259L01981	WIRE HARNESS	-	-	-	-	-	1
W18204160220026	26" BLUE WIRE	-	-	-	-	-	1
0259L01984	WIRE HARNESS	-	-	-	-	-	1
0259L01985	WIRE HARNESS	1	1	1	1	-	-
0259L02106	WIRE HARNESS	-	-	-	-	-	-
0259L02107	WIRE HARNESS	-	-	-	-	-	-
0259L02108	WIRE HARNESS	-	-	-	-	1	-
0259L02109	WIRE HARNESS	-	-	-	-	1	-
0259L02110	WIRE HARNESS	-	-	-	-	1	-
0259L02407	WIRE HARNESS	-	-	-	-	1	-
0259L02408	WIRE HARNESS	-	-	-	-	1	-
0259L02409	WIRE HARNESS	-	-	-	-	1	-
0130L00282	TEMP SWITCH	2	2	2	2	2	2
0130L00279	PRESSURE SWITCH	2	2	2	2	2	2
W18203271271003	3" YELLOW WIRE	2	2	2	2	-	-
0111L00041	1/4" SWIVEL TEE	2	2	2	2	2	4
B1096102	CABLE TIE	3	3	3	3	4	3
0121L04610	T-STAT MOUNT	1	1	1	1	1	1
0163M00097	#10 X 3/4" SCREW	4	4	4	4	4	4
0130M00733	OPTIONAL LOW PRESS. SWITCH	-	-	-	-	2	2

15-25 TON PARTS	DESCRIPTION	LACKLG012	LACKLG013	LACKLG014
0121L04806	TEMP SENSOR MOUNT	1	1	1
M0221817	#10X1/2" SCREW	6	6	4
0130M00178	DPDT RELAY 24VAC	2	3	2
M0216716	#8X3/8" SCREW	4	6	4
0259L02063	WIRE HARNESS	-	1	1
0259L02443	WIRE HARNESS	-	-	1
0259L02065	WIRE HARNESS	1	-	-
0259L02066	WIRE HARNESS	1	1	-
0259L02447	WIRE HARNESS	1	-	-
0259L02445	WIRE HARNESS	-	1	-
0259L02444	WIRE HARNESS	-	-	1
0259L02446	WIRE HARNESS	1	1	-
0130L00282	TEMP SWITCH	2	2	1
0130L00279	PRESSURE SWITCH	2	2	2
0111L00041	1/4" SWIVEL TIE	2	2	2
B1096102	CABLE TIE	20	20	20
0140L07681	WIRING DIAGRAM	-	-	1
0140L07682	WIRING DIAGRAM	1	-	-
0140L07683	WIRING DIAGRAM	-	1	-
0130M00733	OPTIONAL LOW PRESS. SWITCH	2	2	2

3-6 TON INSTALLATION (DB, DR, DF, DS Models)

WARNING

HIGH VOLTAGE
DISCONNECT ALL POWER BEFORE SERVICING OR INSTALLING THIS UNIT. MULTIPLE POWER SOURCES MAY BE PRESENT. FAILURE TO DO SO MAY CAUSE PROPERTY DAMAGE, PERSONAL INJURY OR DEATH.



1. Disconnect all sources of power to the unit, then lockout and tag out. Turn off gas supply if applicable.
2. Remove the Control and Compressor panels. See Figure 1.

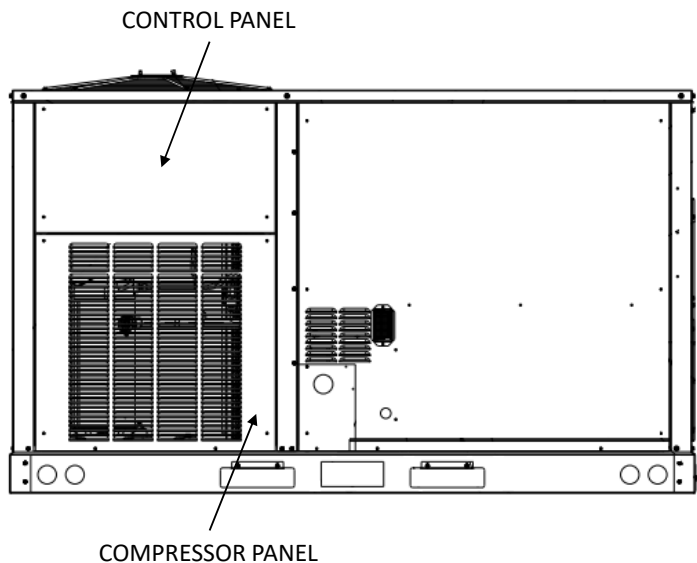

FIGURE 1

3. Attach the LACK Mount to the Accessory Mount using four of the #10 X 1/2" screws.
4. Attach the relay(s) to the LACK Mount using the #8 X 3/8" screws and press the Guide Clips into place. See Figure 2.

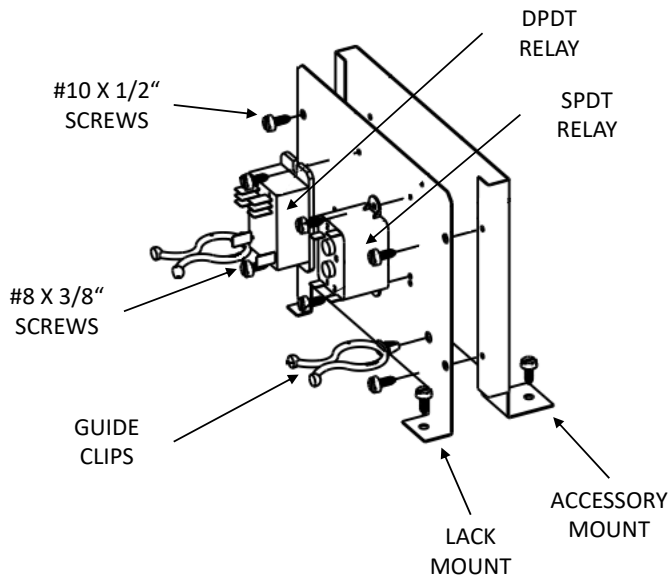

FIGURE 2

5. Slide the rounded tab of the Accessory Mount into the slot in the bottom of the control box. Secure the tabs on the opposite side of the Accessory Mount and LACK Mount to the control box with the two remaining #10 X 1/2" screws. See Figure 3.

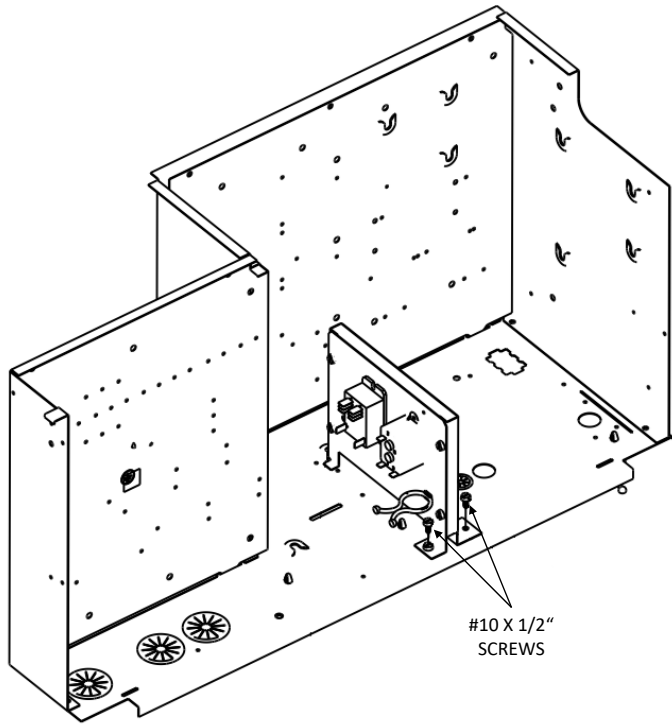

FIGURE 3

- Using one of the Cable Ties, secure the Temperature Switch to the bundle of wires running beneath the control box in the compressor compartment. See figure 4.

NOTE: THE TEMPERATURE SWITCH SHOULD NOT BE WITHIN 6" OF ANY REFRIGERATION COMPONENTS AS IT WILL ADVERSELY AFFECT THE INTENDED FUNCTION.

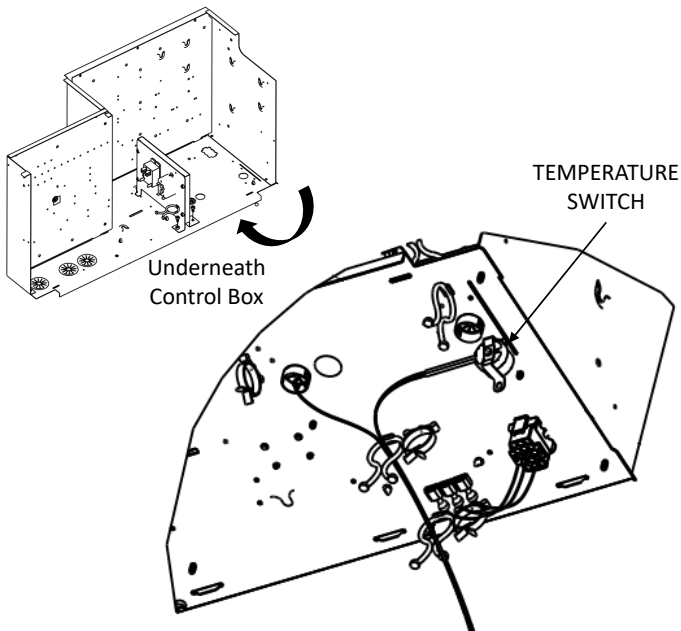

FIGURE 4

- Remove the plastic cap from the liquid line access fitting. See Figure 5.

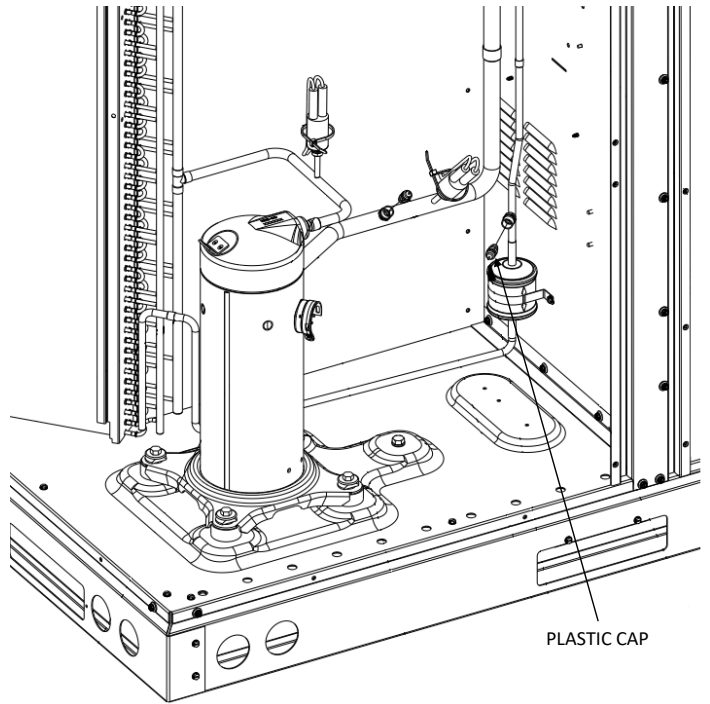

FIGURE 5

- Screw the 1/4" Swivel Tee onto the liquid line access fitting. Torque to 96 ± 5 in-lbs. Use a backup wrench to prevent twisting off the fitting and possible leaks.
- Screw the Pressure Switch onto the branch port of the 1/4" Swivel Tee. Torque to 96 ± 5 in-lbs. Use a backup wrench to prevent twisting off the fitting and possible leaks.

NOTE: NOT FOR DB OR DR MODELS: STEPS 10-11 ARE ONLY NECESSARY IF COOLING OPERATION IS REQUIRED IN CONDITIONS SUSTAINED BELOW 30°F. Please see Considerations, page 1, for details.

- Disconnect the wires from the factory installed low pressure switch and, using a 9/16 wrench, unscrew and remove the low pressure switch from the access fitting.

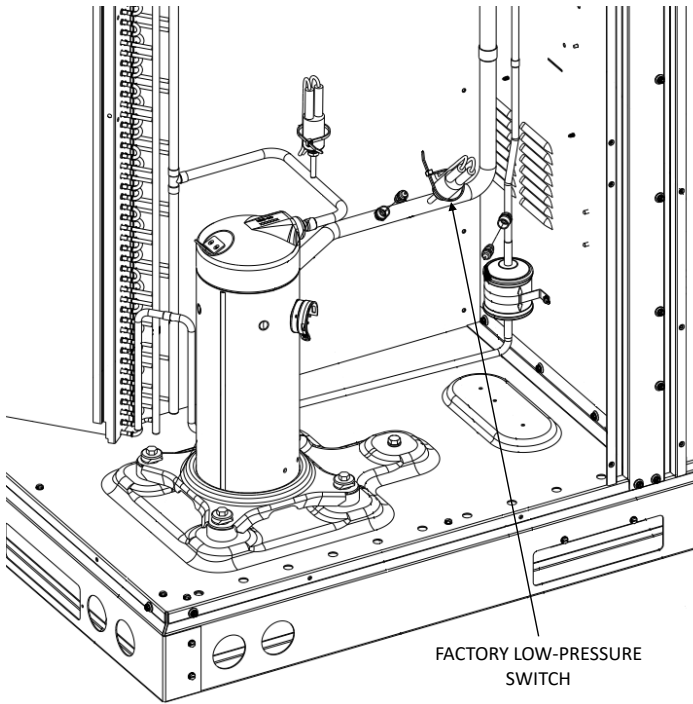



FIGURE 6

11. Install the new low pressure switch included within the kit on this access fitting, torquing it to 96 ±5in/lbs. Reconnect the wires to the switch.

IMPORTANT: ENSURE REFRIGERANT SYSTEM CONNECTIONS ARE TIGHT AND NO LEAKS ARE PRESENT.

12. Route the two wire harnesses and connect the wires as depicted in the routing and wiring diagrams that match the kit being installed.
13. Restore all sources of power to the unit.
14. Test the unit for proper operation.
15. Attach the Control and Compressor panels.

7.5-12.5 TON INSTALLATION (For DR and DB Models)

 WARNING	
<p>HIGH VOLTAGE DISCONNECT ALL POWER BEFORE SERVICING OR INSTALLING THIS UNIT. MULTIPLE POWER SOURCES MAY BE PRESENT. FAILURE TO DO SO MAY CAUSE PROPERTY DAMAGE, PERSONAL INJURY OR DEATH.</p>	

IMPORTANT: LACKMD021 SERVES ALL 7.5-12.5 Ton DB MODELS AND INCLUDES COMPONENTS THAT ARE MODEL-SPECIFIC. THE WIRE HARNESSES USED ARE DEPENDENT ON WHAT MODEL THE KIT IS BEING INSTALLED IN. TO DETERMINE WHICH HARNESSES WILL BE NEEDED, REFER TO THE TABLE BELOW. THIS IS NOT RELEVANT TO DR HIGH EFFICIENCY MODELS.

LACKMD021 HARNESSES NEEDED FOR EACH MODEL	DBC/DBG	DBH 7.5T-10T	DBH 12.5T
0259L01972	X	-	X
0259L01973	X	-	X
W18204160220026	X	-	-
0259L01977	-	X	-
0259L01979	-	X	-
0259L01980	-	-	X
0259L01981	-	X	-
0259L01984	X	-	X
0259L01985	-	X	-

1. Disconnect all sources of power to the unit, then lockout and tag out. Turn off gas supply if applicable.
2. Remove the Control, Blower and Compressor panels. See Figure 7 & 8.

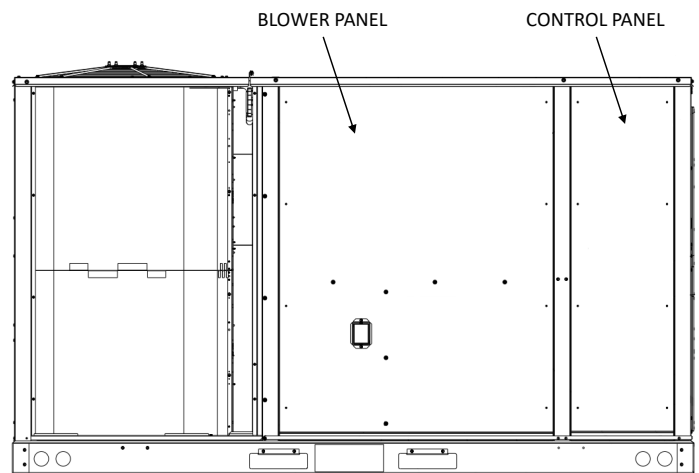
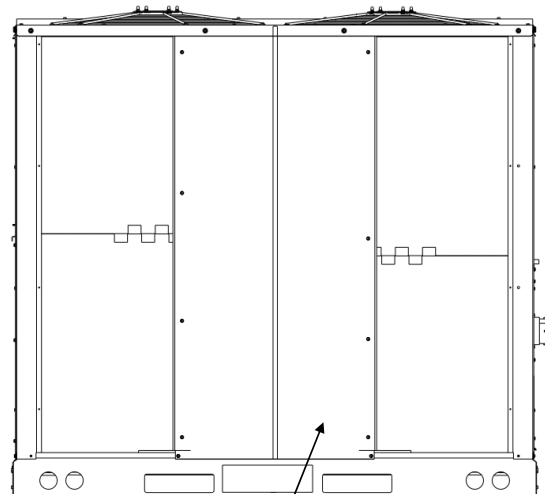

FIGURE 7



COMPRESSOR PANEL

FIGURE 8

NOTE: STEPS 3-6 DIFFER DEPENDING ON WHETHER THE UNIT UTILIZES DDC OR ELECTROMECHANICAL CONTROLS.

FOR DDC

3. Attach the DDC LACK Mount to the Accessory Mount using two of the #10 X 1/2" screws.
4. Attach the relays to the LACK Mount using the #8 X 3/8" screws. See Figure 9.

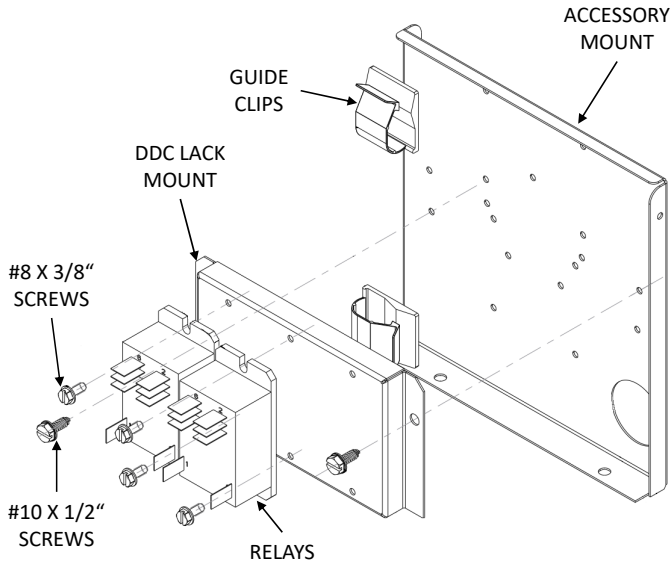

FIGURE 9

5. Attach Accessory Mount with the DDC LACK Mount and relays to the control box with the two remaining #10 X 1/2" screw. See Figure 10.

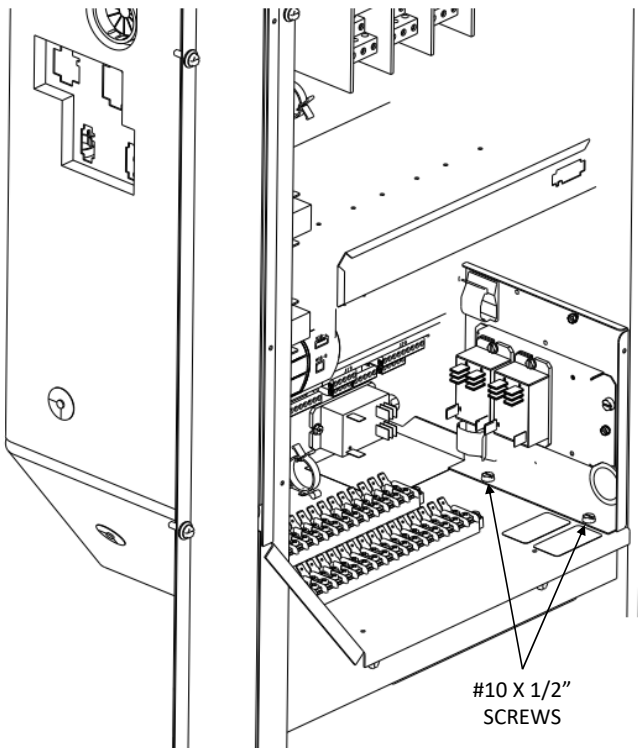

FIGURE 10

FOR ELECTROMECHANICAL CONTROLS

3. Slide the two rounded tabs of the LACK Mount into slots on the new Voltage Barrier. Secure the LACK Mount to the new Voltage Barrier using two of the #10 X 1/2" screws.
4. Attach the relay(s) to the LACK Mount using the #8 X 3/8" screws and press the Guide Clips into place. See Figure 11.

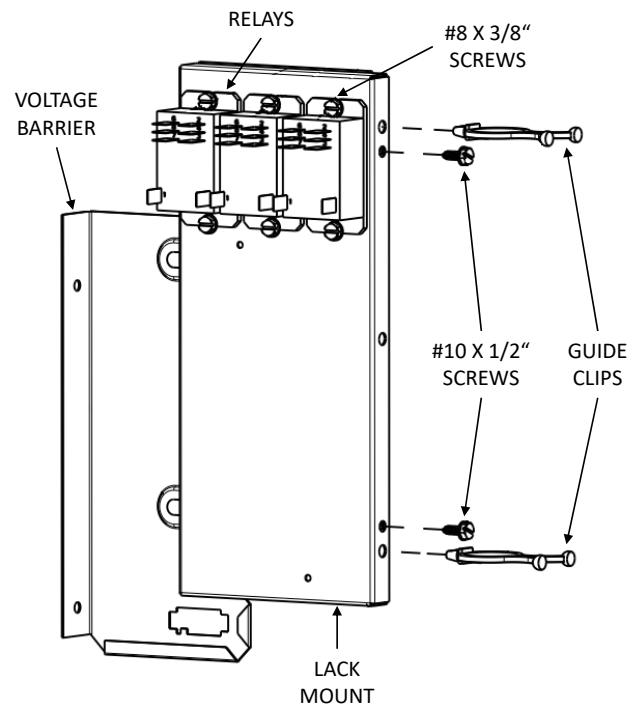

FIGURE 11

5. Remove the existing voltage barrier from the unit control box. See Figure 12.

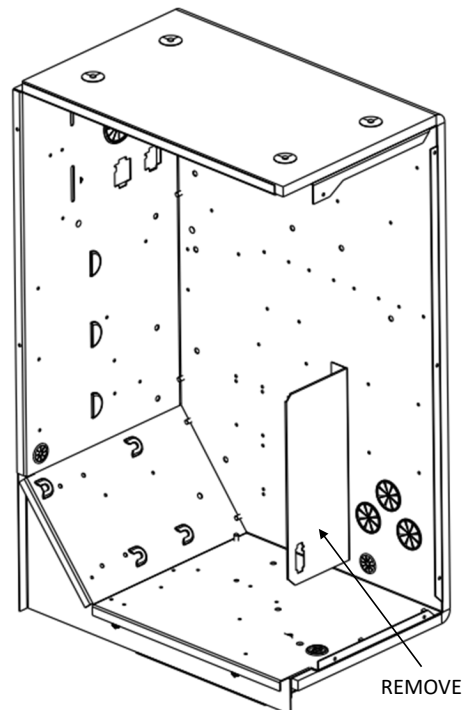

FIGURE 12

- Attach the new Voltage Barrier with the LACK Mount and relays to the control box using the existing #10 X 1/2" screws. See Figure 13.

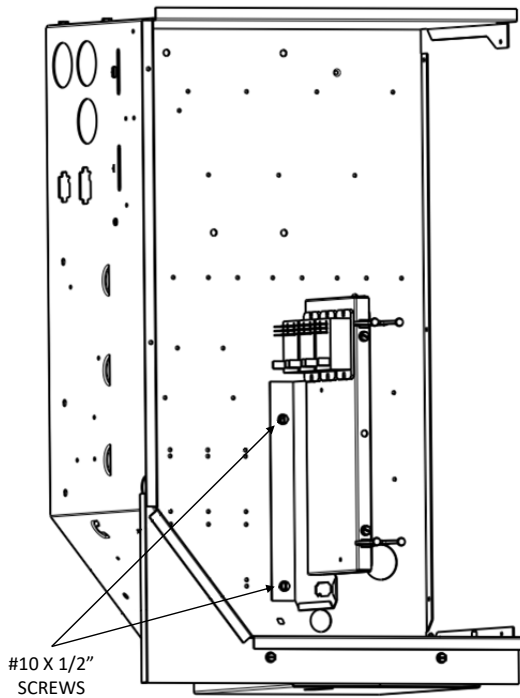

FIGURE 13

- Using the T-Stat Mount as a template, pre-drill two holes (7/32") per temperature switch in the corner of the duct panel. The bottom of the T-Stat Mount should be about 12" above the floor of the control box. See Figure 14.

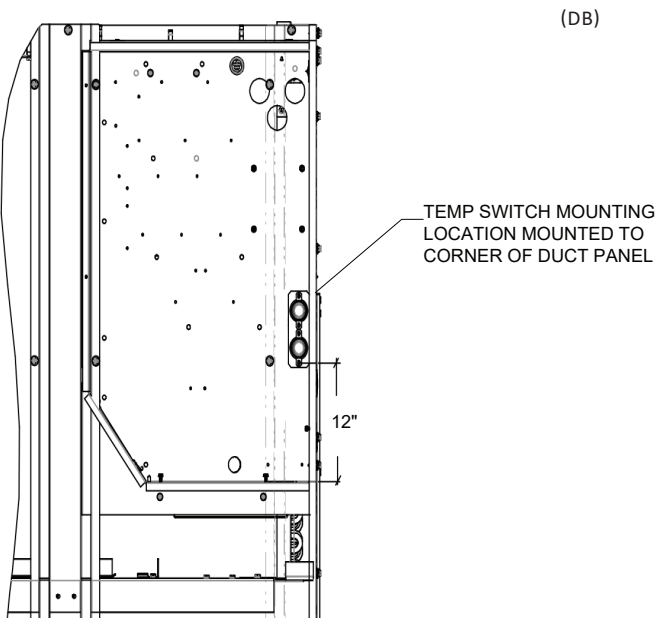

FIGURE 14

- Pass the Temperature Switch wires through the T-Stat Mount and align the holes. See Figure 15.

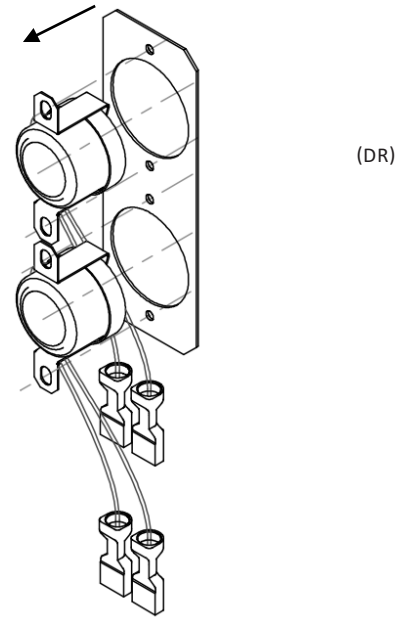

FIGURE 15

- Attach the Temperature Switch(es) and the T-Stat Mount to the inside of the corner of the duct panel using two #10 X 3/4" washered screws per switch.

NOTE: THE TEMPERATURE SWITCH(ES) SHOULD NOT BE MOUNTED TO AN INSULATED SURFACE AS IT WILL ADVERSELY AFFECT THE INTENDED FUNCTION.

- Remove the plastic caps from the two liquid line access fittings. See Figure 16 & 17.

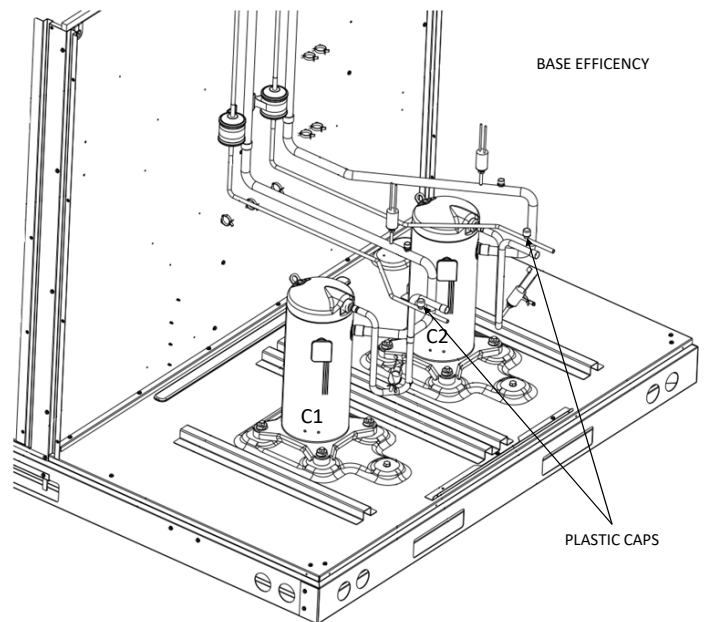

FIGURE 16

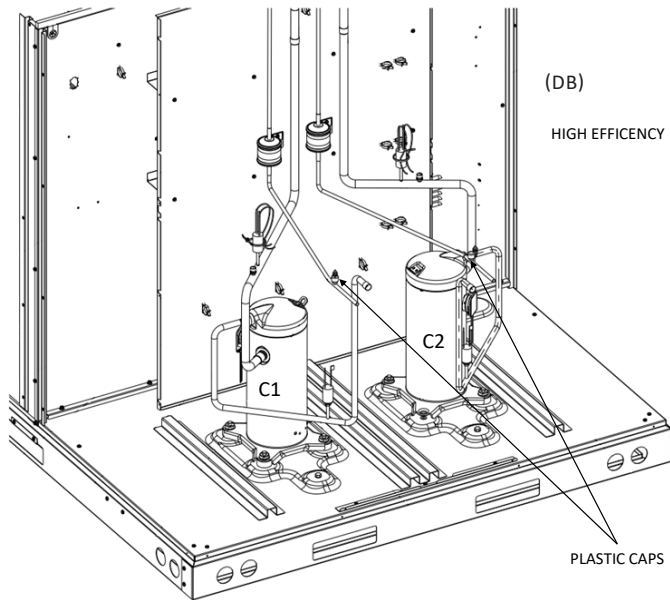

FIGURE 17

11. Screw a 1/4" Swivel Tee onto each of the two liquid line access fittings. Torque to 96 ± 5 in-lbs. Use a backup wrench to prevent twisting off the fitting and possible leaks.
12. Screw a Pressure Switch onto the branch port of each of the 1/4" Swivel Tees. Torque to 96 ± 5 in-lbs. Use a backup wrench to prevent twisting off the fitting and possible leaks

NOTE: STEPS 13-15 ONLY APPLY TO DB MODELS AND ARE ONLY NECESSARY IF COOLING OPERATION IS REQUIRED IN EXTREME CONDITIONS. PLEASE SEE CONSIDERATIONS, PAGE 1, FOR DETAILS. DO NOT FOLLOW STEPS 13-15 FOR DR MODEL UNITS.

13. Locate the low pressure access fittings next to the factory low pressure switches (See Figure 18). Remove the plastic caps, and install the 3rd and 4th Swivel-Tees provided in the kit onto these fittings. Torque to 96 ± 5 in-lbs. Use a backup wrench to prevent twisting off the fitting and possible leaks.

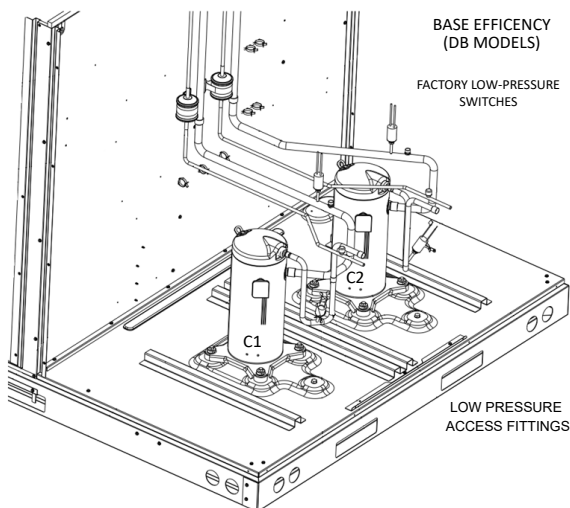

FIGURE 18

14. Screw one of the optional Low Pressure Switches provided in the kit onto the branch port of each of the 1/4 Swivel Tees installed in step 13. Torque to 96 ± 5 in-lbs. Use a back up wrench to prevent twisting off the fitting and possible leaks.
15. Disconnect the wires from the factory installed low pressure switches located on the suction lines. Attach the wires to the new low pressure switches installed onto the Swivel-Tees in step 14.

IMPORTANT: ENSURE REFRIGERANT SYSTEM CONNECTIONS ARE TIGHT AND NO LEAKS ARE PRESENT.

16. Route the wire harnesses and connect the wires as depicted in the routing and wiring diagrams that match the kit being installed.
17. Restore all sources of power to the unit.
18. Test the unit for proper operation.
19. Attach the Control, Blower, and Compressor panels.

7.5-12.5 TON INSTALLATION (For DF, DS, AND DH Models)

WARNING
<p>HIGH VOLTAGE DISCONNECT ALL POWER BEFORE SERVICING OR INSTALLING THIS UNIT. MULTIPLE POWER SOURCES MAY BE PRESENT. FAILURE TO DO SO MAY CAUSE PROPERTY DAMAGE, PERSONAL INJURY OR DEATH.</p>

IMPORTANT: LACKMD020 SERVES ALL 7.5-12.5 Ton DF, DS, AND DH MODELS AND INCLUDES COMPONENTS THAT ARE MODEL-SPECIFIC. THE WIRE HARNESSES USED ARE DEPENDENT ON WHAT MODEL THE KIT IS BEING INSTALLED IN. TO DETERMINE WHICH HARNESSES WILL BE NEEDED, REFER TO THE TABLE BELOW.

LACKMD020 HARNESSES NEEDED FOR EACH MODEL	DFC/DFG	DFH	DSC/DSG	DSH	DHC/DHG 7.5T-10T	DHC/DHC 12.5T	DHC/DHG WITH DDC CONTROL 7.5T-10T	DHC/DHG WITH DDC CONTROL 12.5T
0259L01977	X	X	X	X	X	X	X	X
0259L02108	X	-	X	-	X	X	X	X
0259L02109	X	X	X	X	X	X	X	X
0259L02110	-	X	-	X	-	-	-	-
0259L02407	X	X	X	X	X	-	X	-
0259L02408	X	X	X	X	X	-	X	-
0259L02409	-	-	-	-	-	X	-	X

1. Disconnect all sources of power to the unit, then lockout and tag out. Turn off gas supply if applicable.

2. Remove the Control, Blower and Compressor panels. See Figure 20 & 21.

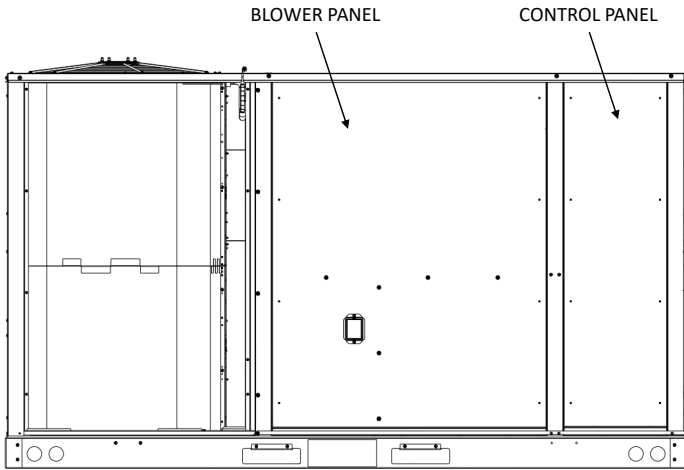
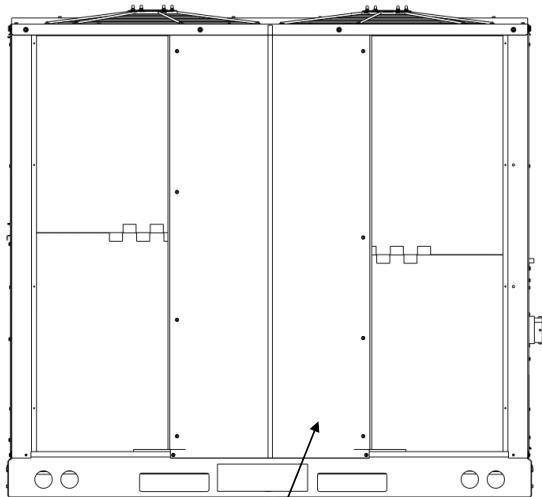

FIGURE 20



COMPRESSOR PANEL

FIGURE 21

3. Attach the relays to the Control box location as shown in Figure 22.

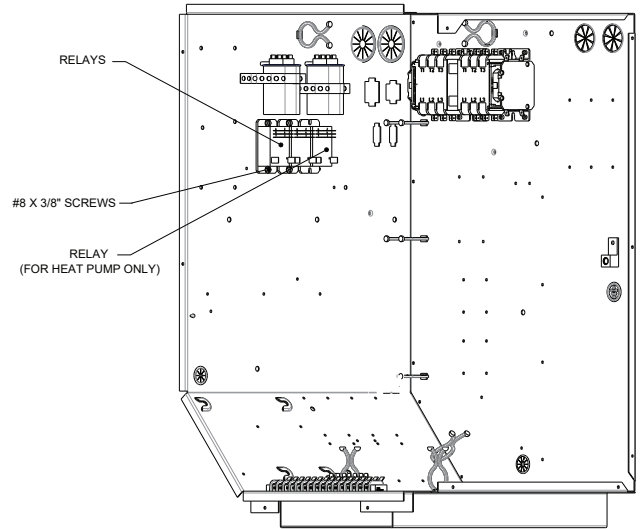

FIGURE 22

4. Pre-drill two holes ($7/32$ ") in the corner of the duct panel at the two pre-formed dimples. If there are no dimples, use the T-Stat Mount as a template. The bottom of the T-Stat Mount should be about 12" above the floor of the control box. See Figure 23.

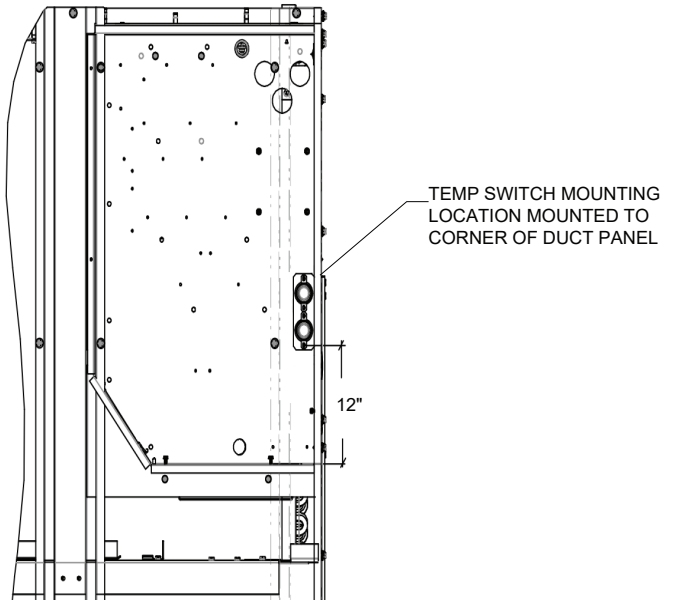

FIGURE 23

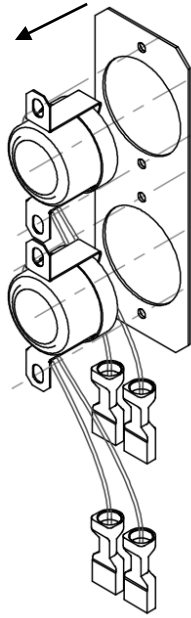

FIGURE 24

5. Pass the Temperature Switch wires through the T-Stat Mount and align the holes. See Figure 24.
6. Attach the Temperature Switch(es) and the T-Stat Mount to the inside of the corner post using two #10 X 3/4" washered screws per switch.

NOTE: THE TEMPERATURE SWITCH(ES) SHOULD NOT BE MOUNTED TO AN INSULATED SURFACE AS IT WILL ADVERSELY AFFECT THE INTENDED FUNCTION.

NOTE: STEPS 7-9 DIFFER BETWEEN DF MODELS AND DS/DH MODELS

FOR DS AND DH MODELS:

7. Remove plastic caps from the two smaller liquid line fittings. See Figures below for location of correct fittings.
8. Screw a Pressure Switch onto these two liquid line fittings. Torque to 96 ± 5 in-lbs. Use a backup wrench to prevent twisting off the fitting and possible leaks.

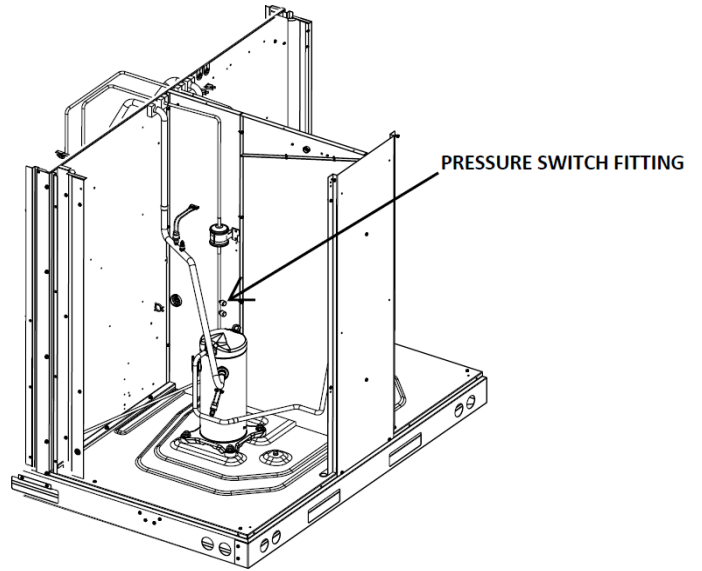

DS MODELS

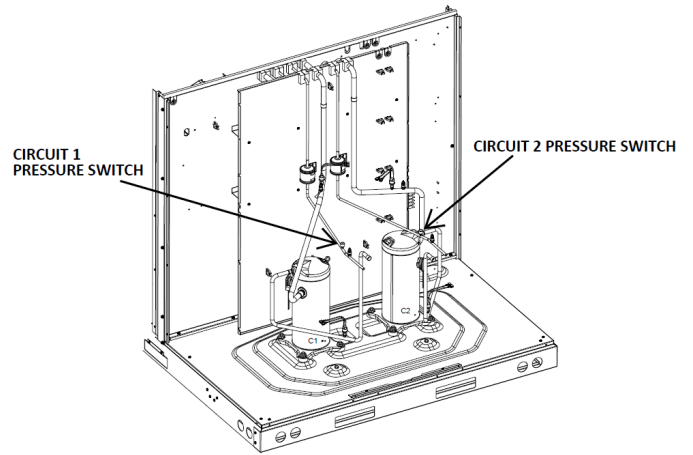

DH MODELS

FOR DF MODELS:

7. Remove the plastic caps from the two liquid line access fittings. See Figure 25.

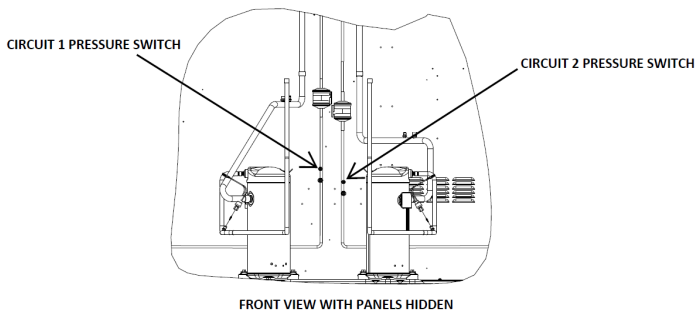

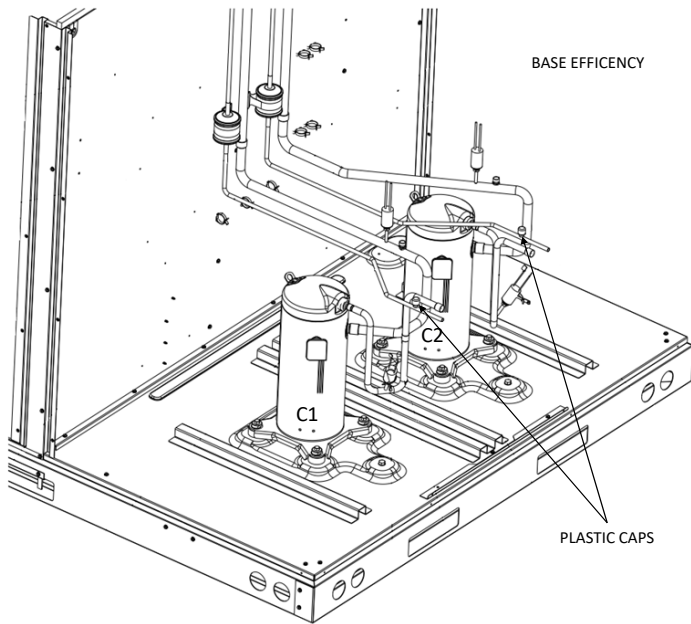

FIGURE 25

8. Screw a 1/4" Swivel Tee onto each of the two liquid line access fittings. Torque to 96 ± 5 in-lbs. Use back up wrench to prevent twisting off the fitting and possible leaks.
9. Screw a Pressure Switch onto the branch port of each of the 1/4" Swivel Tees. Torque to 96 ± 5 in-lbs. Use back up wrench to prevent twisting off the fitting and possible leaks.

NOTE: STEPS 10-11 ARE ONLY NECESSARY IF COOLING OPERATION IS REQUIRED IN CONDITIONS SUSTAINED BELOW 30°F. PLEASE SEE CONSIDERATIONS, PAGE 1, FOR DETAILS.

10. Disconnect the wires from the factory installed low-pressure switches and, using a 9/16 wrench, unscrew and remove the low pressure switches from their respective access fittings.

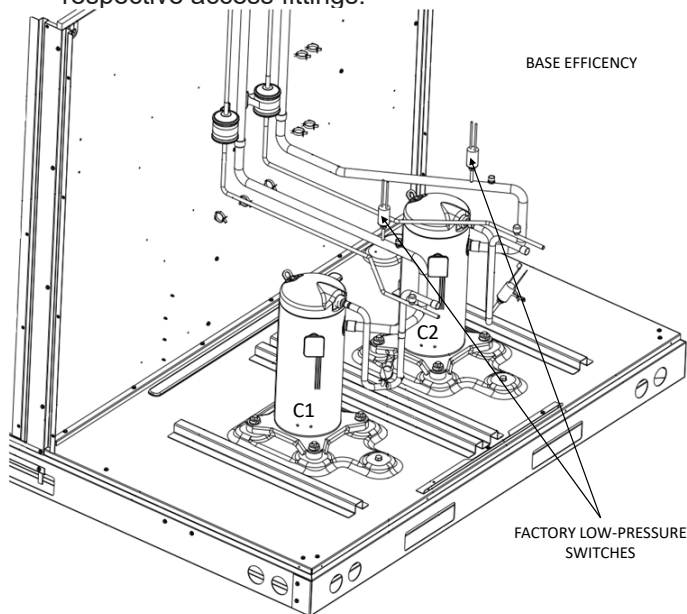

FIGURE 26

11. Install the new low pressure switches included within the kit on these access fittings, torquing them to 96 ± 5 in/lbs. Reconnect the wires to their respective switch.

IMPORTANT: ENSURE REFRIGERANT SYSTEM CONNECTIONS ARE TIGHT AND NO LEAKS ARE PRESENT.

12. Route the wire harnesses and connect the wires as depicted in the routing and wiring diagrams that match the kit being installed.
13. Restore all sources of power to the unit.
14. Test the unit for proper operation.
15. Attach the Control, Blower, and Compressor panels.

15-25 TON INSTALLATION



WARNING

HIGH VOLTAGE

DISCONNECT ALL POWER BEFORE SERVICING OR INSTALLING THIS UNIT. MULTIPLE POWER SOURCES MAY BE PRESENT. FAILURE TO DO SO MAY CAUSE PROPERTY DAMAGE, PERSONAL INJURY OR DEATH.



1. Disconnect all sources of power to the unit, then lockout and tag out. Turn off gas supply if applicable.
2. Remove the Control, Filter, Blower Coil, Blower panels, and Condenser Grills or Hail Guard. See Figure 27 & 28.

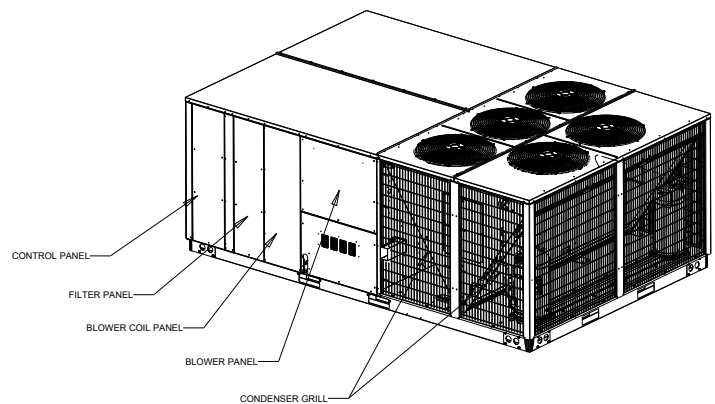

FIGURE 27

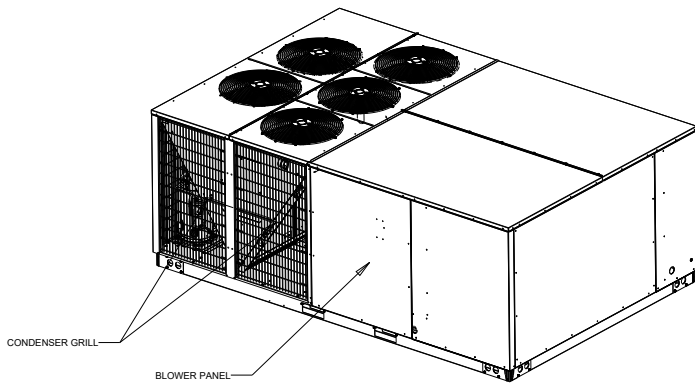

FIGURE 28

3. Remove Capacitor Box Cover, attach the relays to the capacitor plate using #8 X 3/8" screws. See Figure 29.

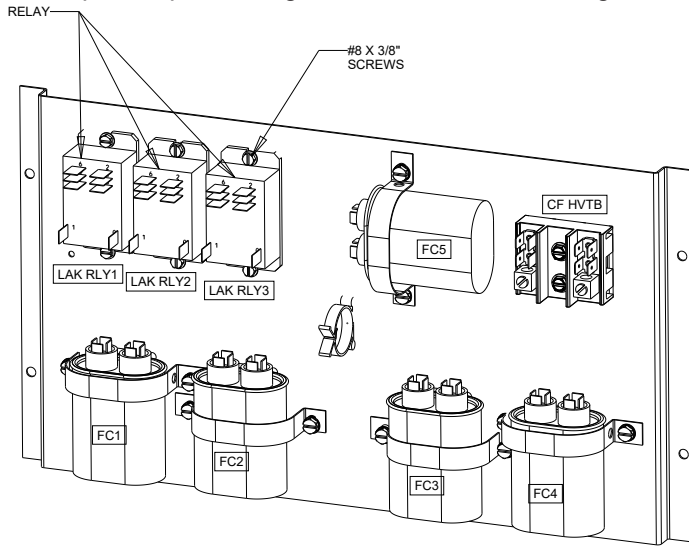

FIGURE 29

4. Attach the Temperature Switch(es) and the T-Stat Mount to the outside partition panel using the #10 X 3/4" screws. See Figure 30 & 31.

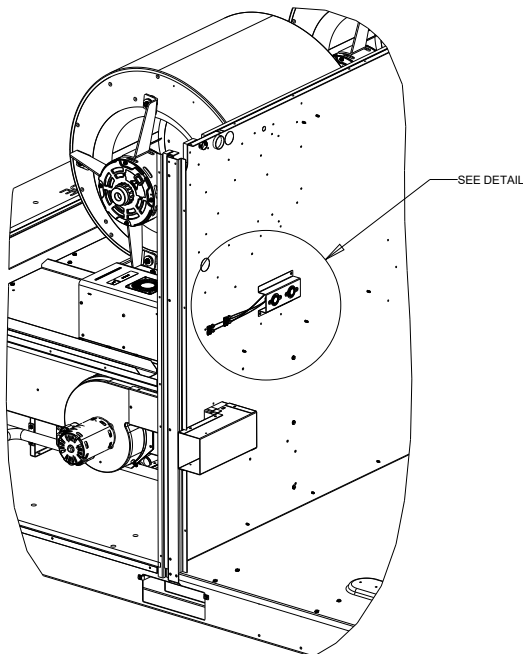

FIGURE 30

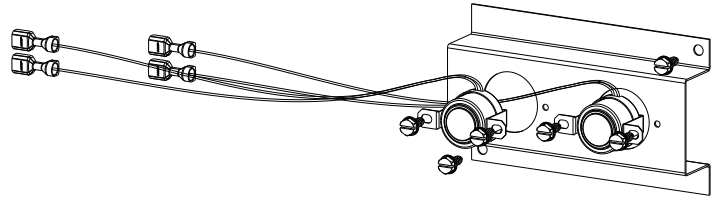

FIGURE 31

5. Remove the plastic caps from the two discharge line access fittings. See Figure 32 & 33.

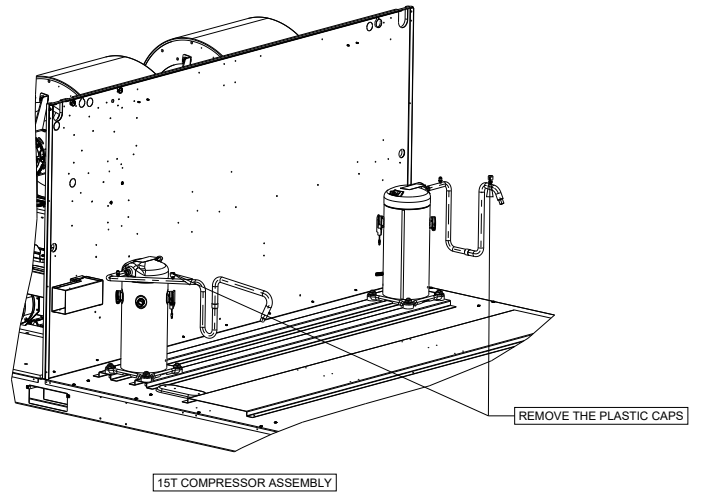

FIGURE 32

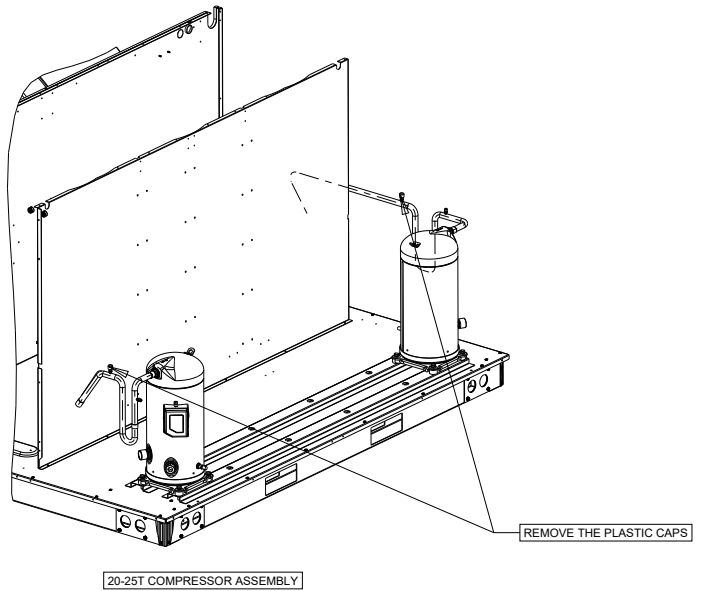

FIGURE 33

6. Screw a 1/4" Swivel Tee onto each of the two discharge line access fittings. Torque to 96 ± 5 in-lbs. Use a backup wrench to prevent twisting off the fitting and possible leaks.

7. Screw a Pressure Switch onto the run port of each of the 1/4" Swivel Tees. Torque to 96 ± 5 in-lbs. Use a backup wrench to prevent twisting off the fitting and possible leaks. See Figure 34.

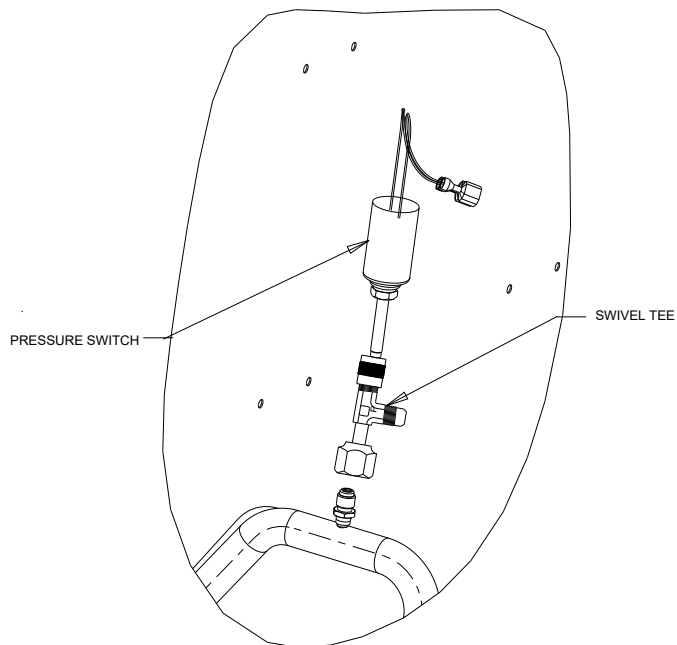

FIGURE 34

NOTE: STEPS 8-9 ARE ONLY NECESSARY IF COOLING OPERATION IS REQUIRED IN CONDITIONS SUSTAINED BELOW 30°F. PLEASE SEE CONSIDERATIONS, PAGE 1, FOR DETAILS.

8. Disconnect the wires from the factory installed low pressure switches and, using a 9/16 wrench, unscrew and remove the low pressure switches from their respective access fittings.
9. Install the new low pressure switches included within the kit on these access fittings, torquing them to 96 ± 5 in/lbs. Reconnect the wires to their respective switch.

IMPORTANT: ENSURE REFRIGERANT SYSTEM CONNECTIONS ARE TIGHT AND NO LEAKS ARE PRESENT.

10. Route the wire harnesses and connect the wires as depicted in the routing and wiring diagrams that match the kit being installed. See Figure 36.

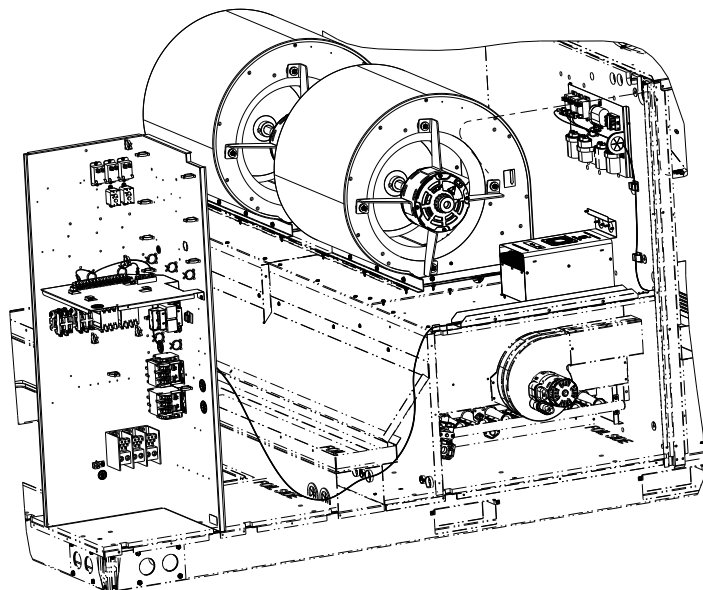

FIGURE 35

11. Restore all sources of power to the unit.
12. Test the unit for proper operation.
13. Attach the Control, Filter, Blower Coil, Blower panels and Condenser Grills or Hail Guard.

WIRING LEGEND

Wire Code

— . . . — . . . — FACTORY WIRING
————— FIELD WIRING

Components

CAP - CAPCITOR	FC - FAN CAPACITOR	PLM - PLUG MALE
CC# - COMPRESSOR CONTACTOR	GND - GROUND	PS - PRESSURE SWITCH
COMP - COMPRESSOR	LAK - LOW AMBIENT KIT	RLY# - RELAY
F# - FUSE	PB - POWER BLOCK	TB# - TERMINAL BOARD
FB - FUSE BLOCK	PLF - PLUG FEMALE	TS - TEMPERATURE SWITCH

Colors

BK - BLACK	OR - ORANGE
BR - BROWN	PK - PINK
BL - BLUE	RD - RED
GR - GREEN	YL - YELLOW

LACKSM011 WIRING DIAGRAM AND ILLUSTRATION

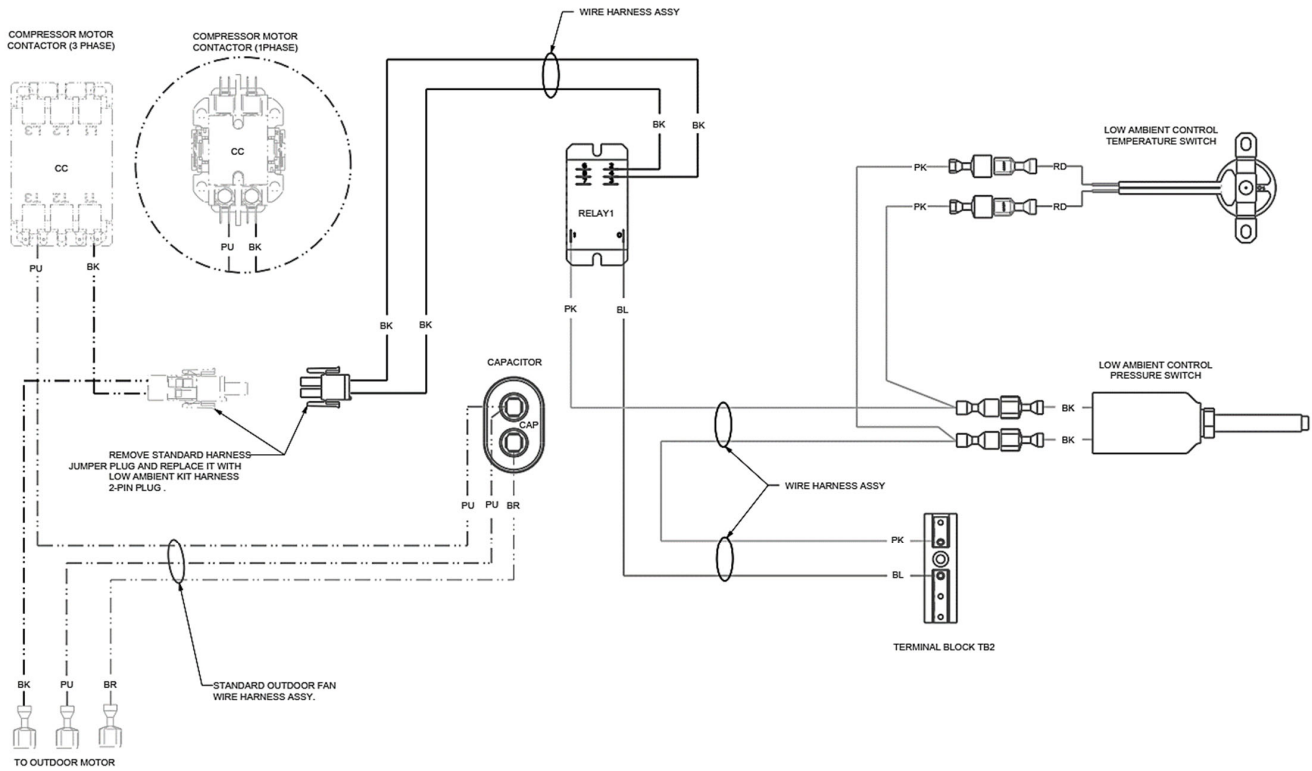
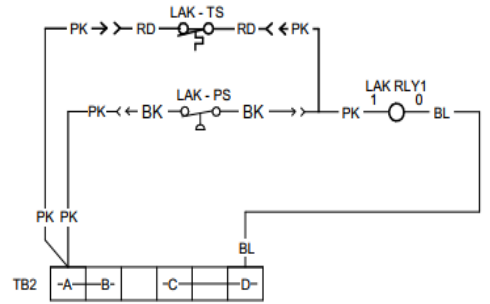
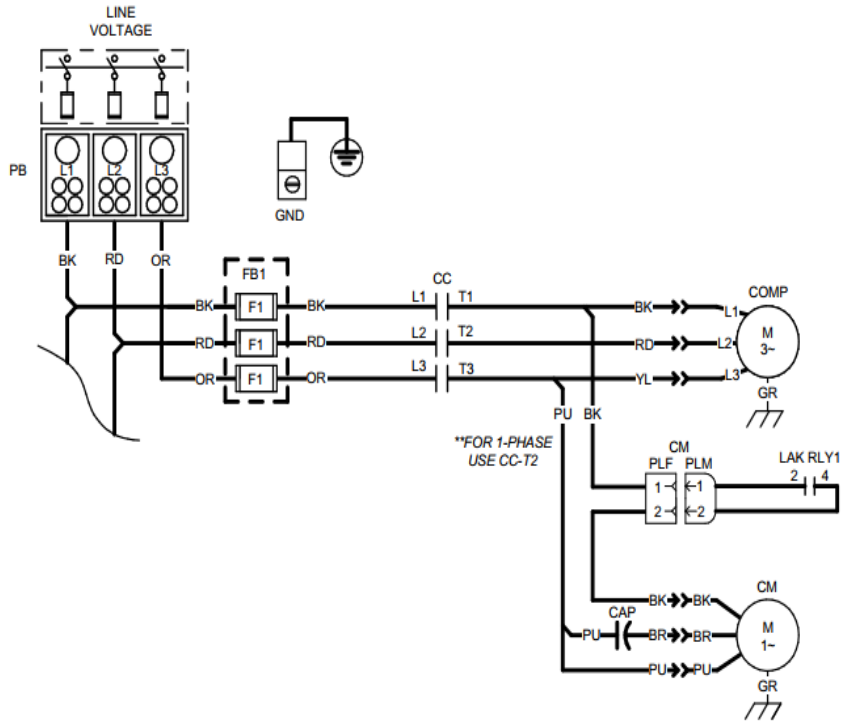

LOW AMBIENT CONTROLS WIRING- AC/GAS MODELS (PSC OUTDOOR MOTOR)

LACKSM012 WIRING DIAGRAM AND ILLUSTRATION

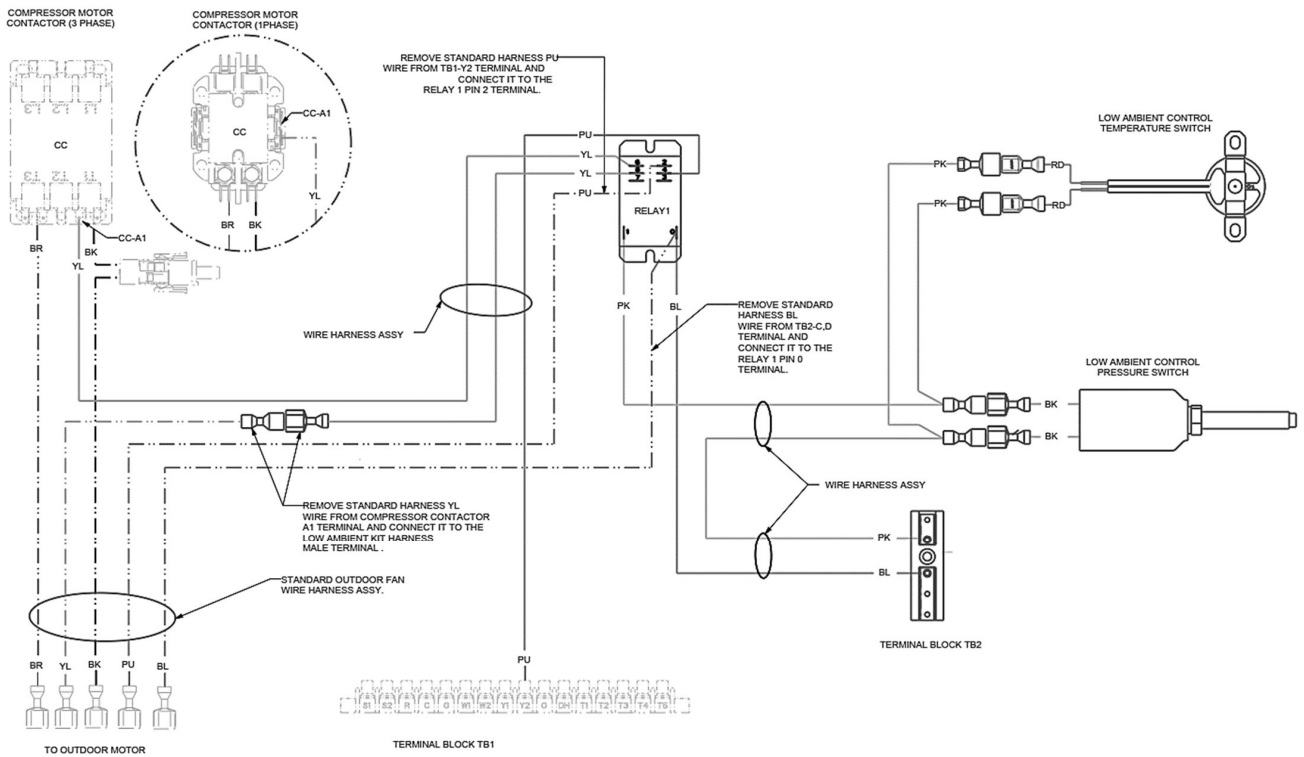
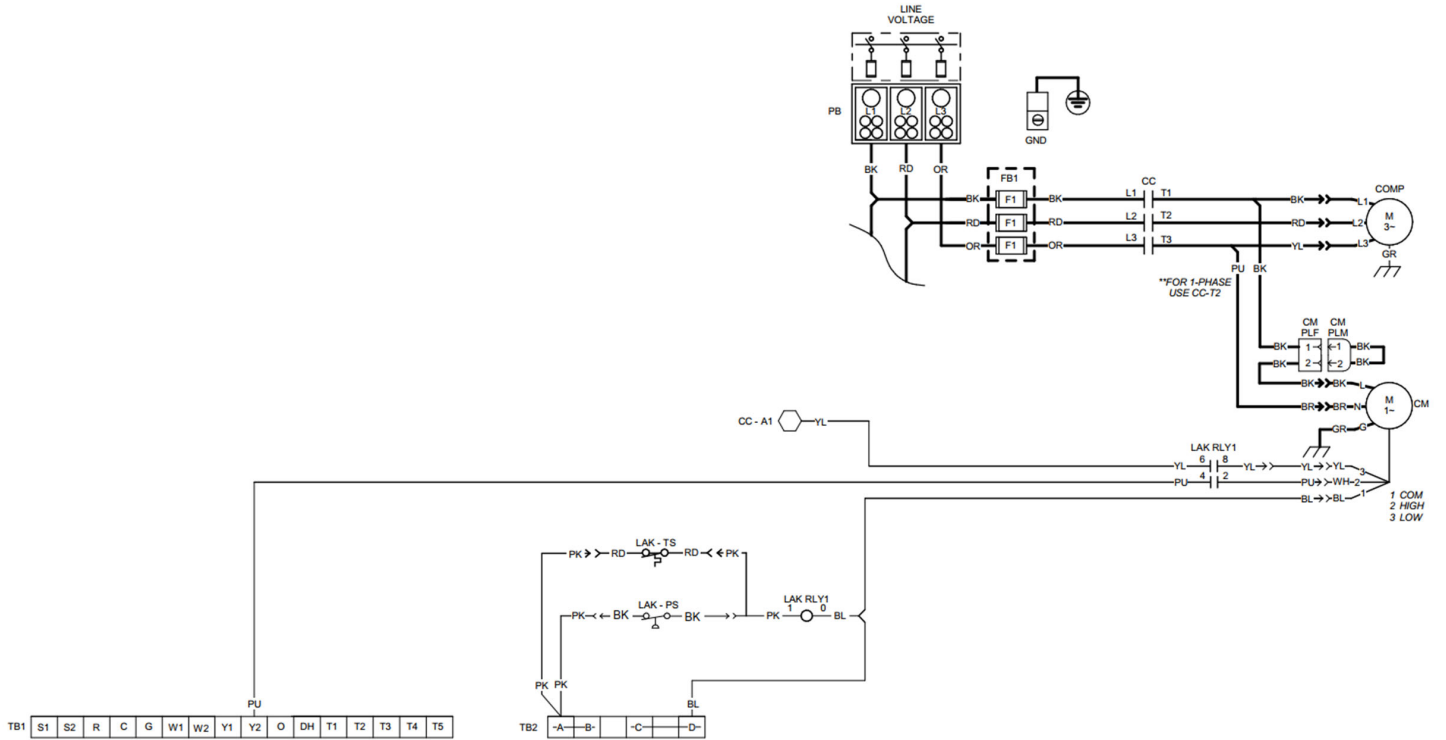

LOW AMBIENT CONTROLS WIRING - AC/GAS MODELS
(ECM OUTDOOR MOTOR)

LACKSM013 WIRING DIAGRAM AND ILLUSTRATION

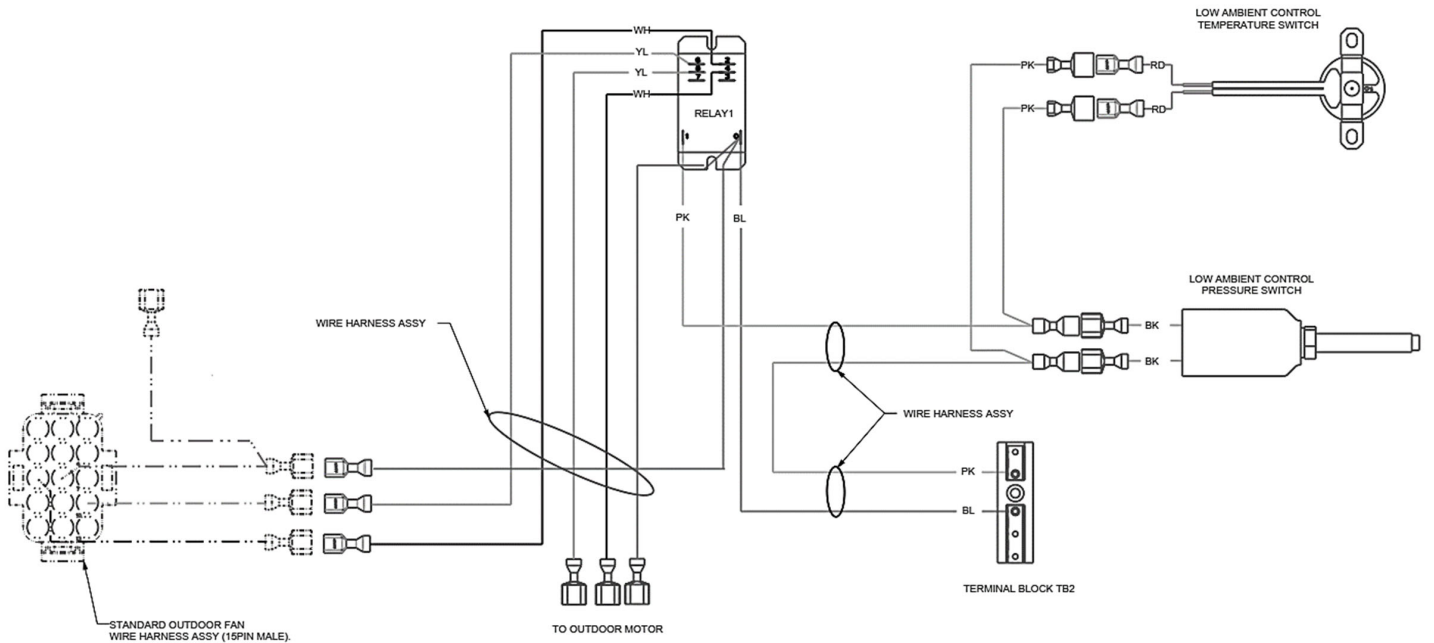
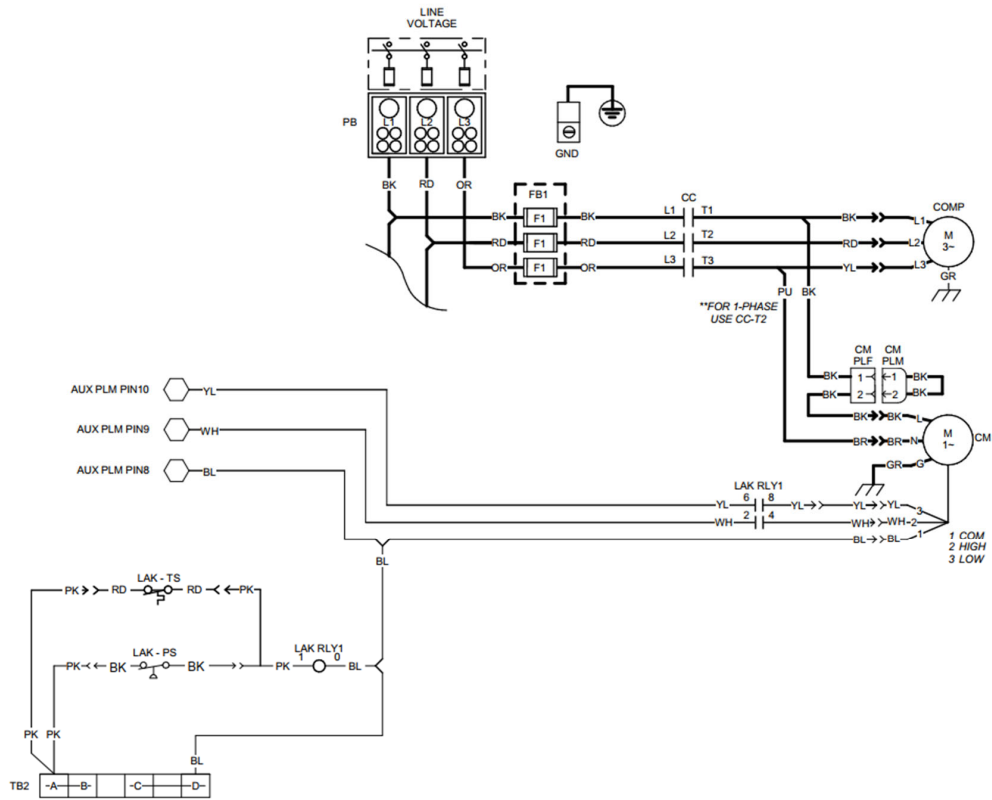

LOW AMBIENT CONTROLS WIRING - DDC AC/GAS MODELS
(ECM OUTDOOR MOTOR)

LACKSM014 WIRING DIAGRAM AND ILLUSTRATION

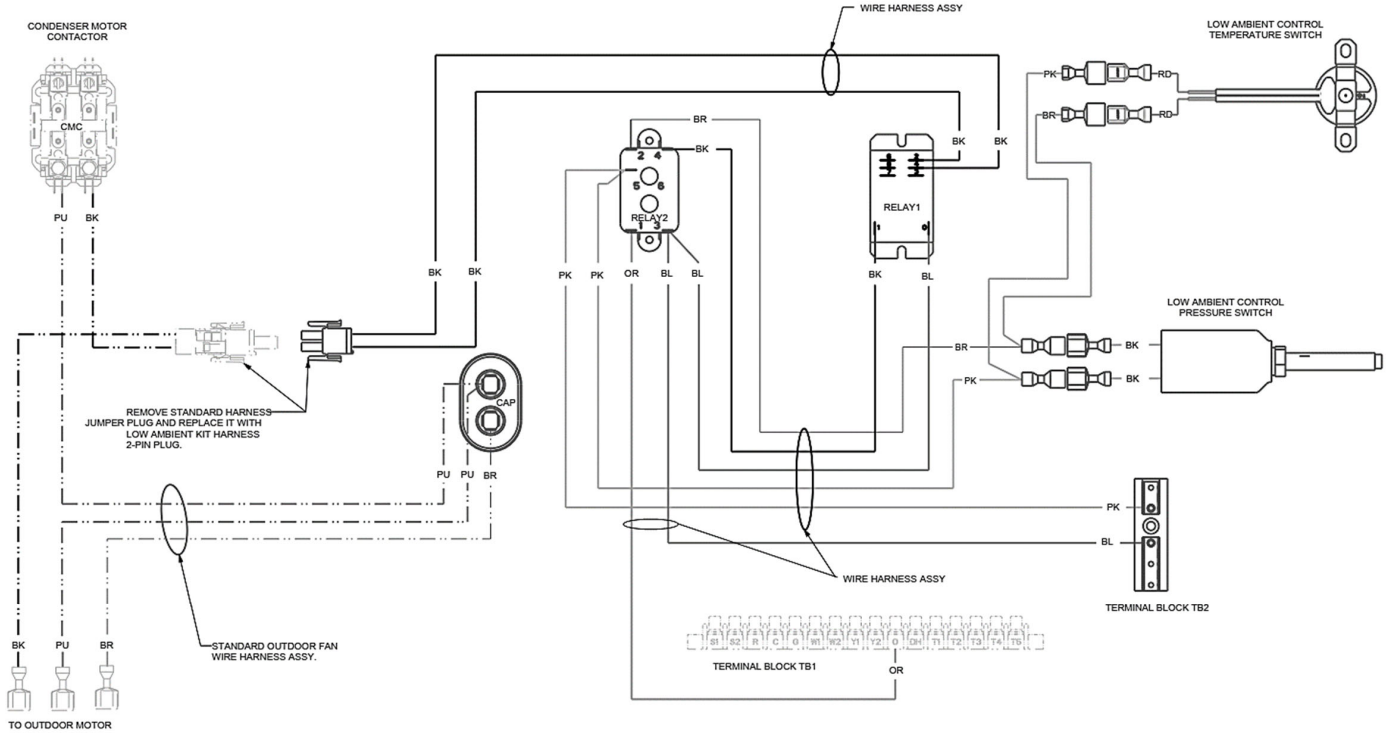
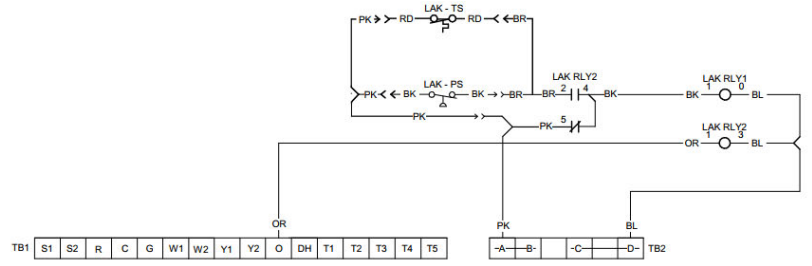
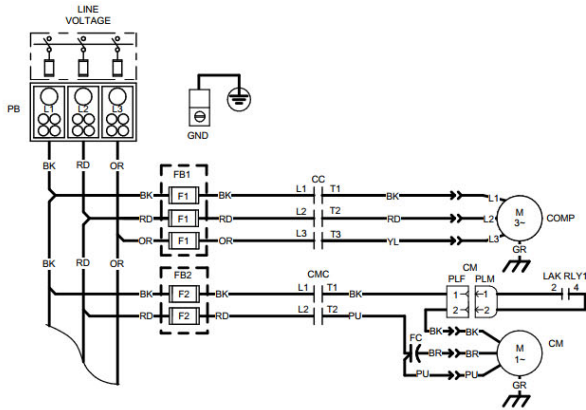

LOW AMBIENT CONTROLS WIRING HP MODELS (PSC OD MOTOR)

LACKSM015 WIRING DIAGRAM AND ILLUSTRATION

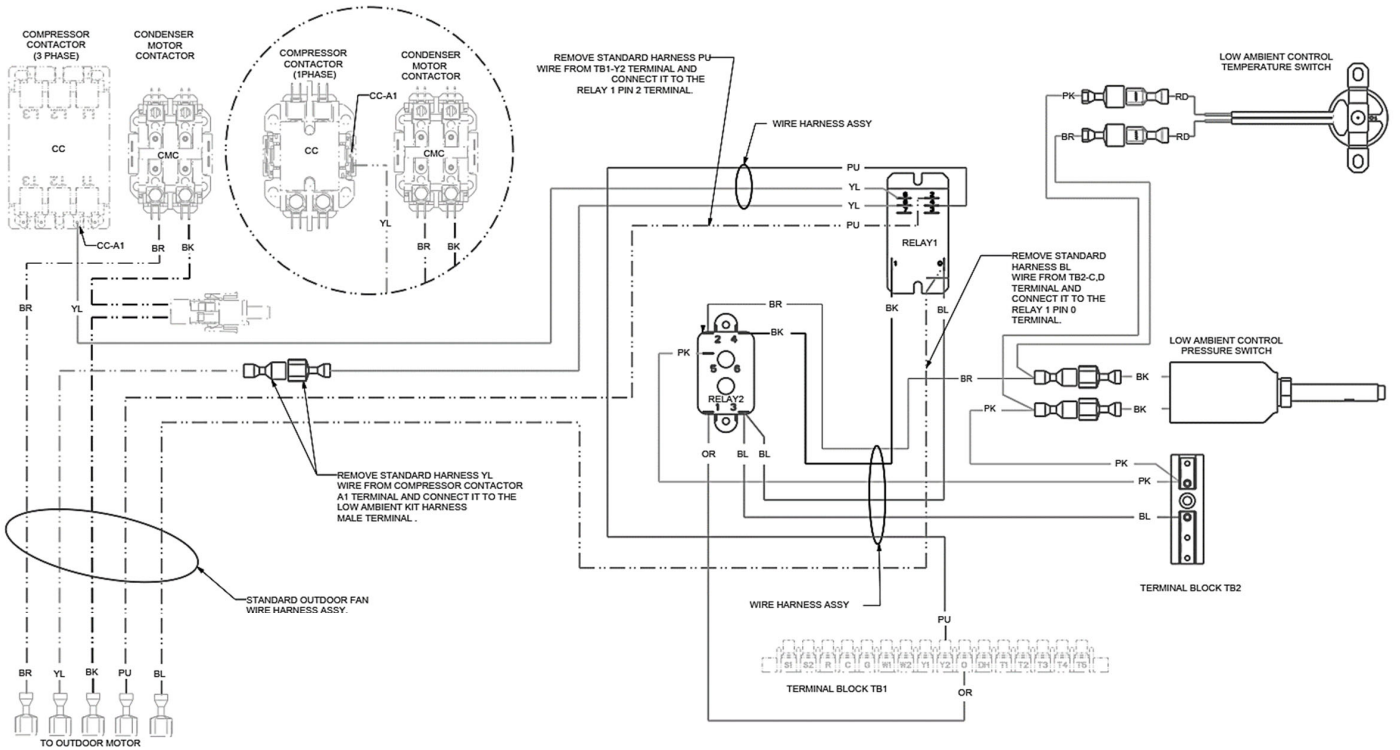
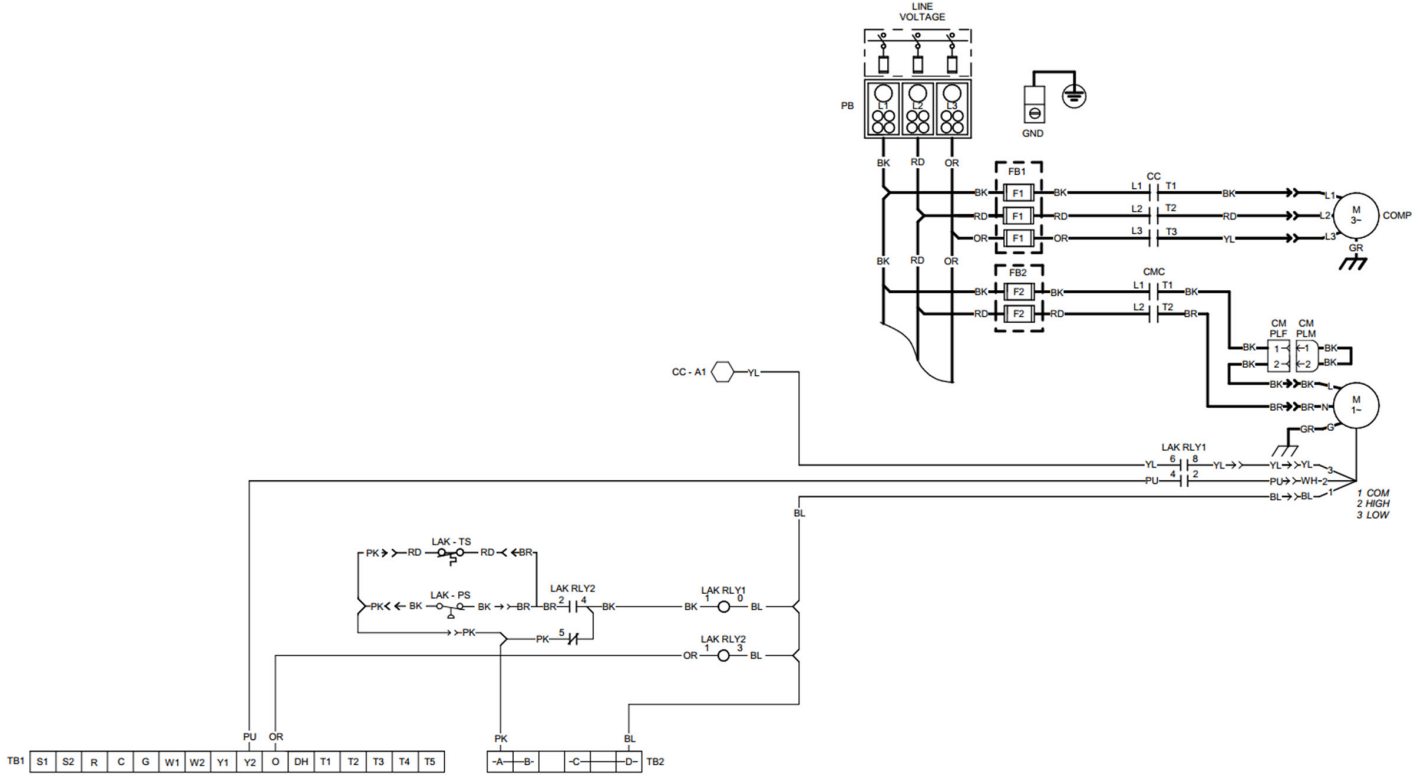

LOW AMBIENT CONTROLS WIRING HP MODELS (ECM OD MOTOR)

LACKSM016 WIRING DIAGRAM AND ILLUSTRATION

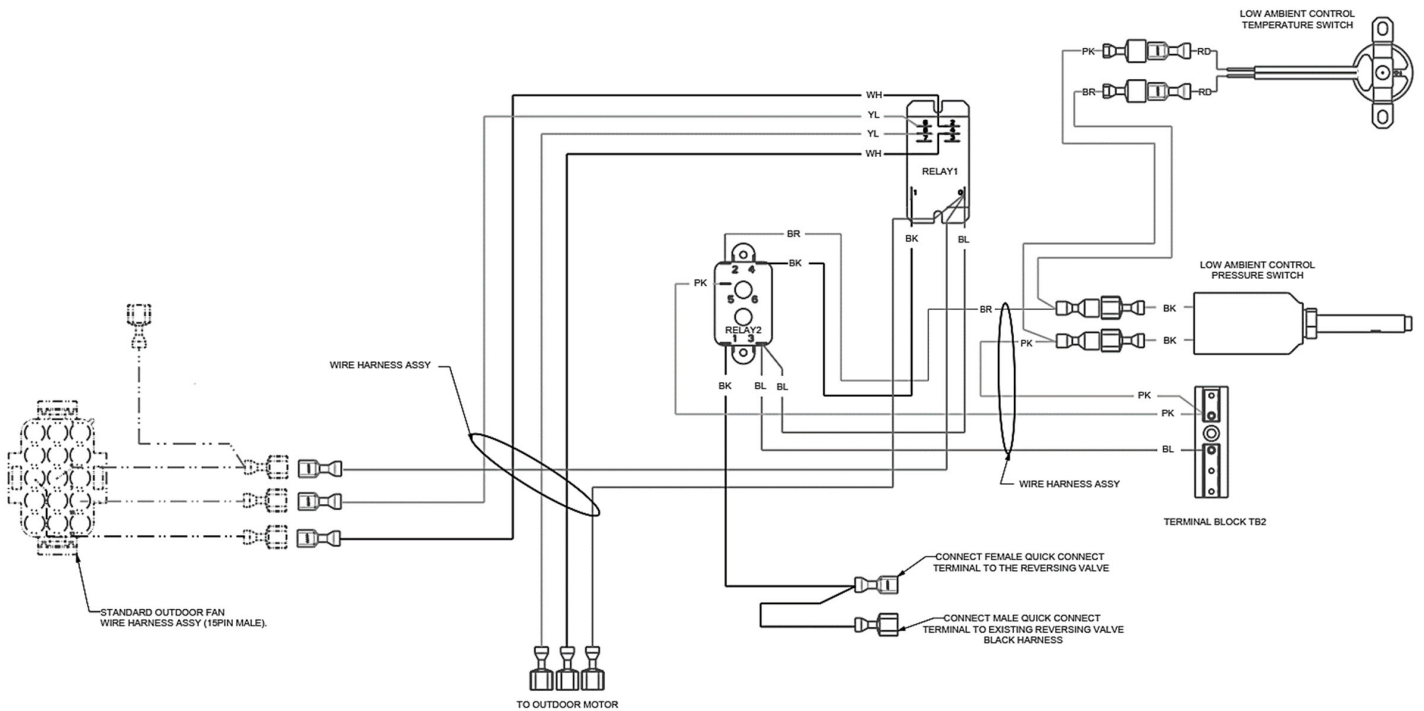
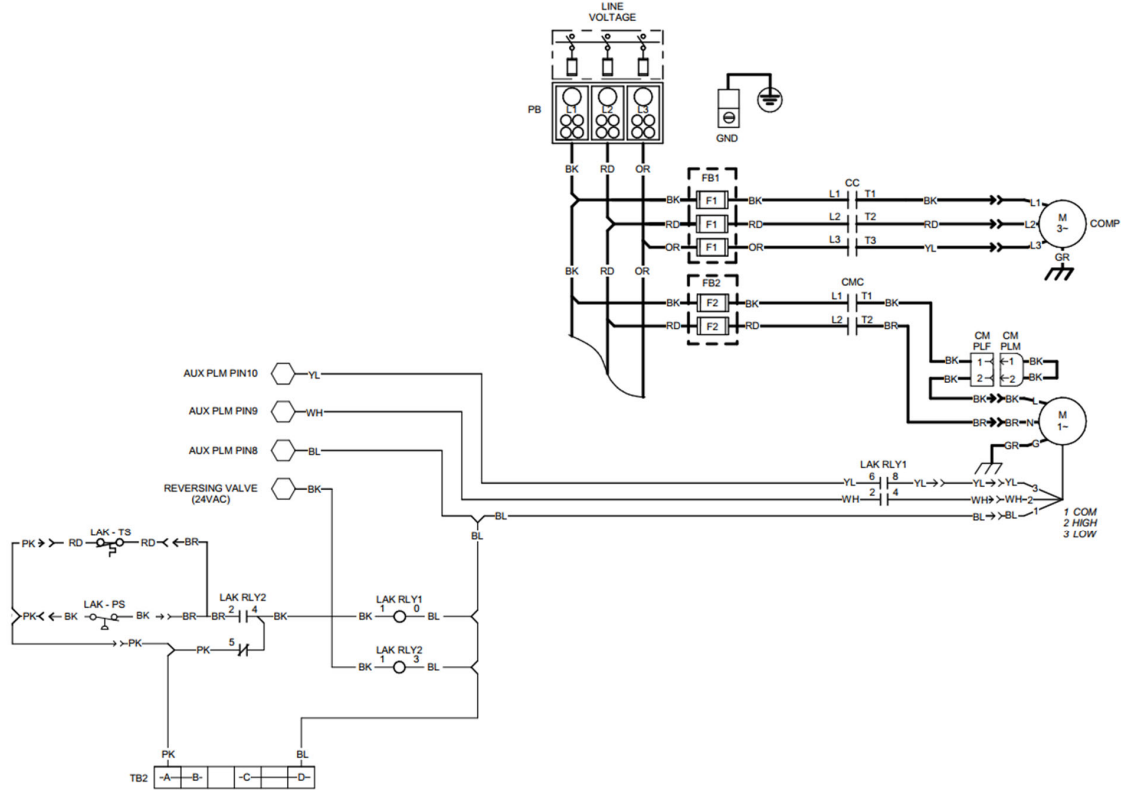

LOW AMBIENT CONTROLS WIRING HP MODELS - DDC (ECM OD MOTOR)

7.5-12.5 TON PRESSURE SWITCH ROUTING

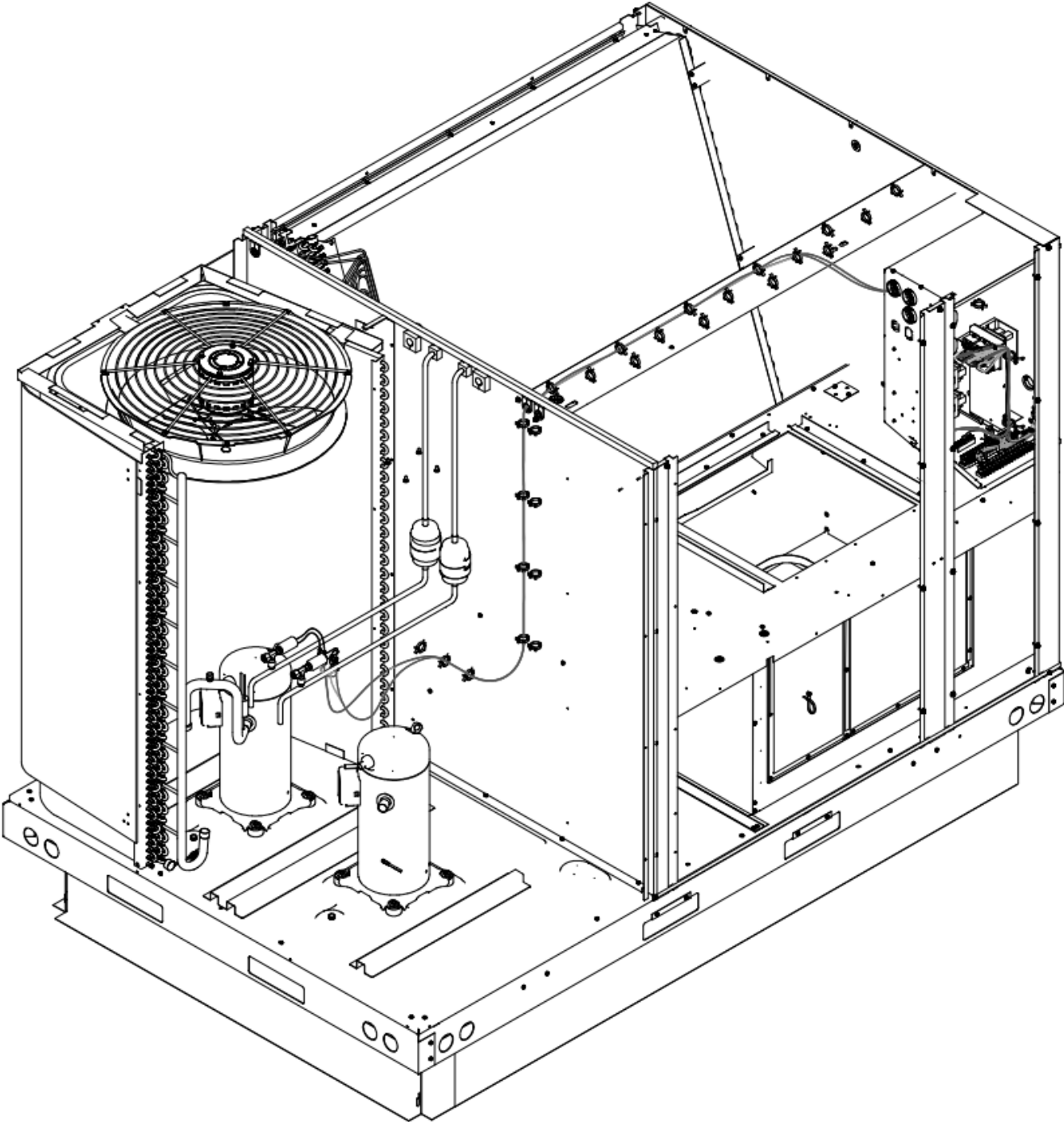

DB MODELS

7.5-12.5 TON PRESSURE SWITCH ROUTING

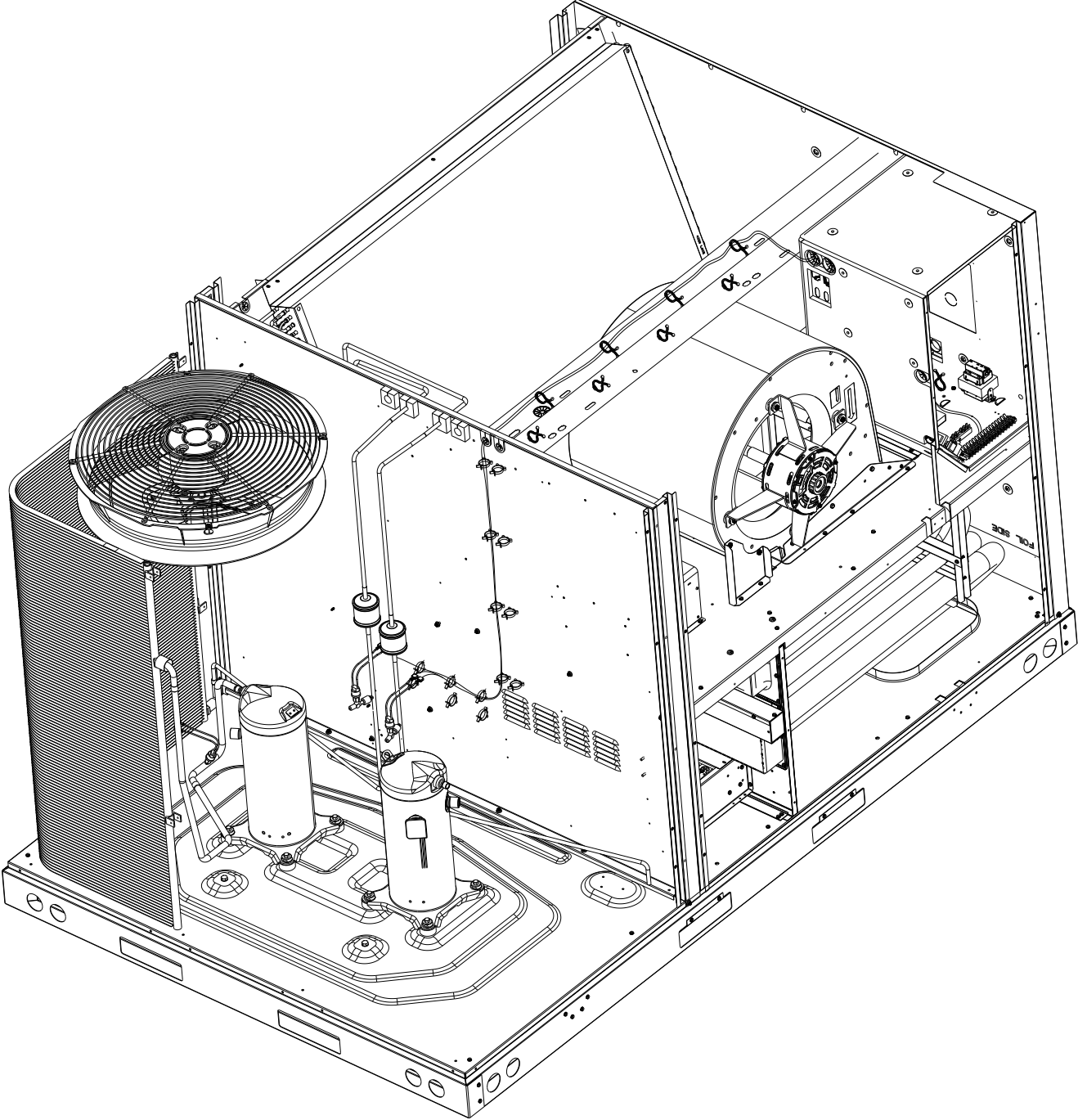

DF MODELS

7.5-12.5 TON PRESSURE SWITCH ROUTING

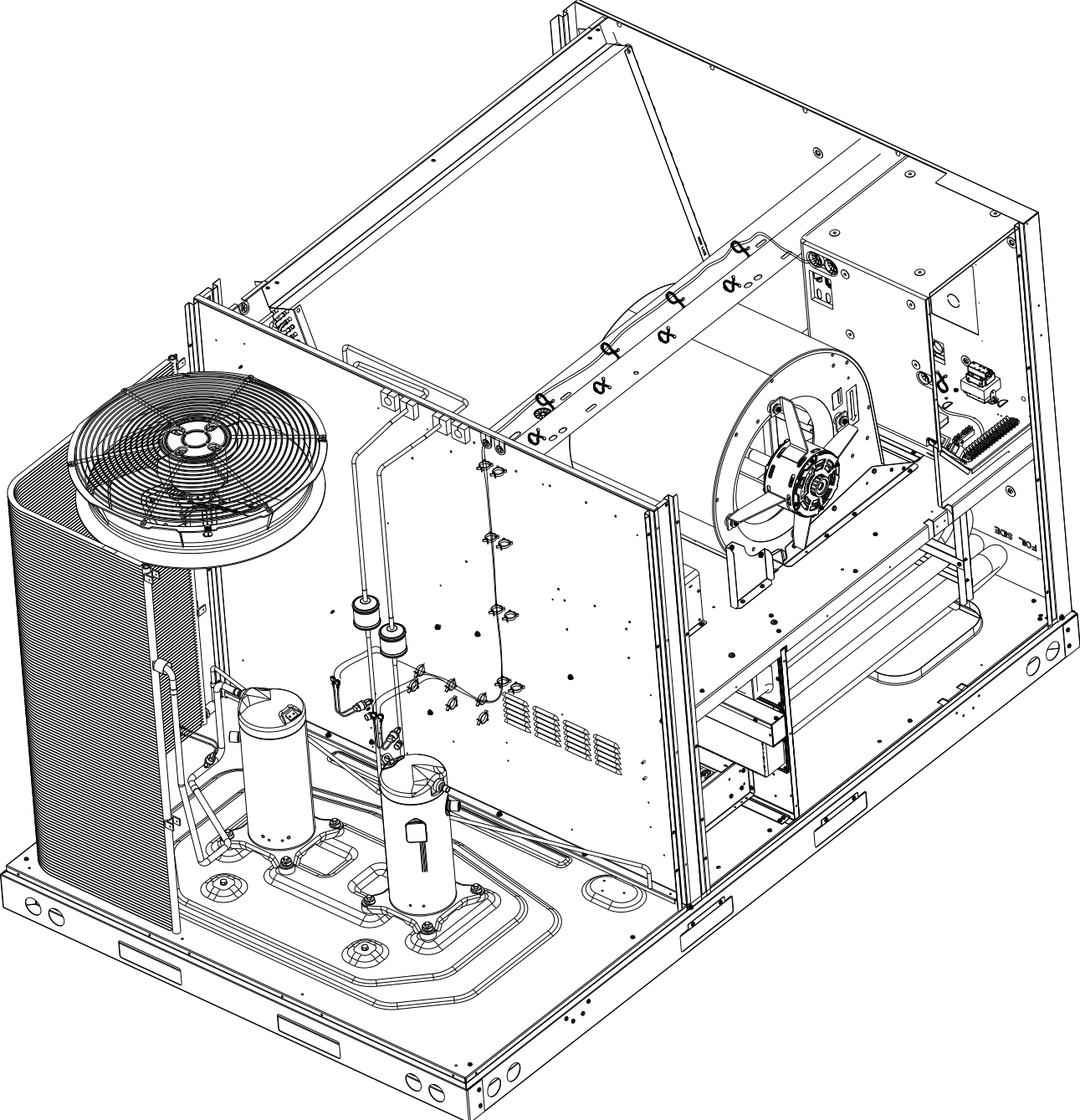

DS MODELS

7.5-12.5 TON PRESSURE SWITCH ROUTING

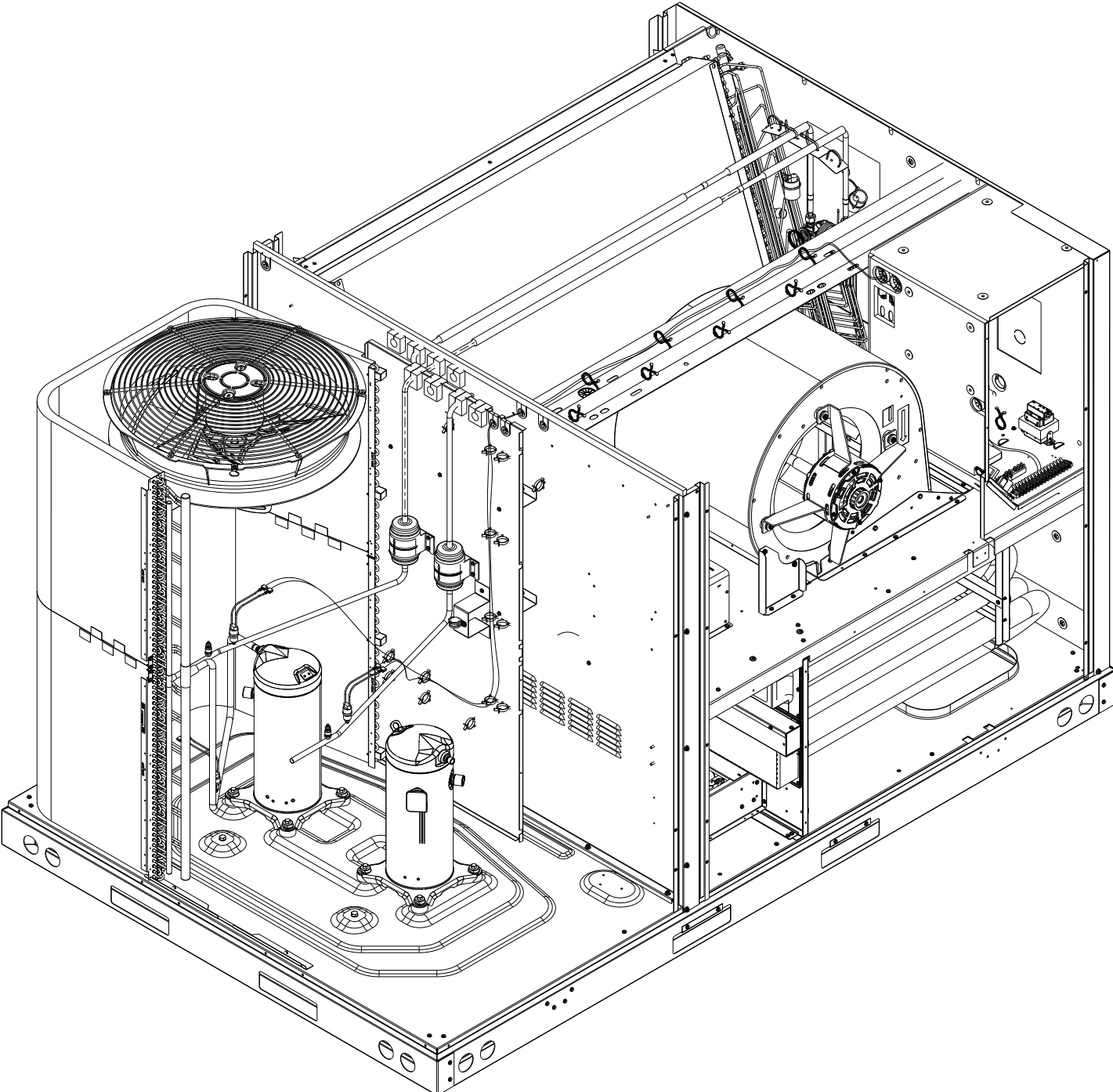

DH MODELS

LACKMD012 & LACKMD016 WIRING DIAGRAM AND ILLUSTRATION

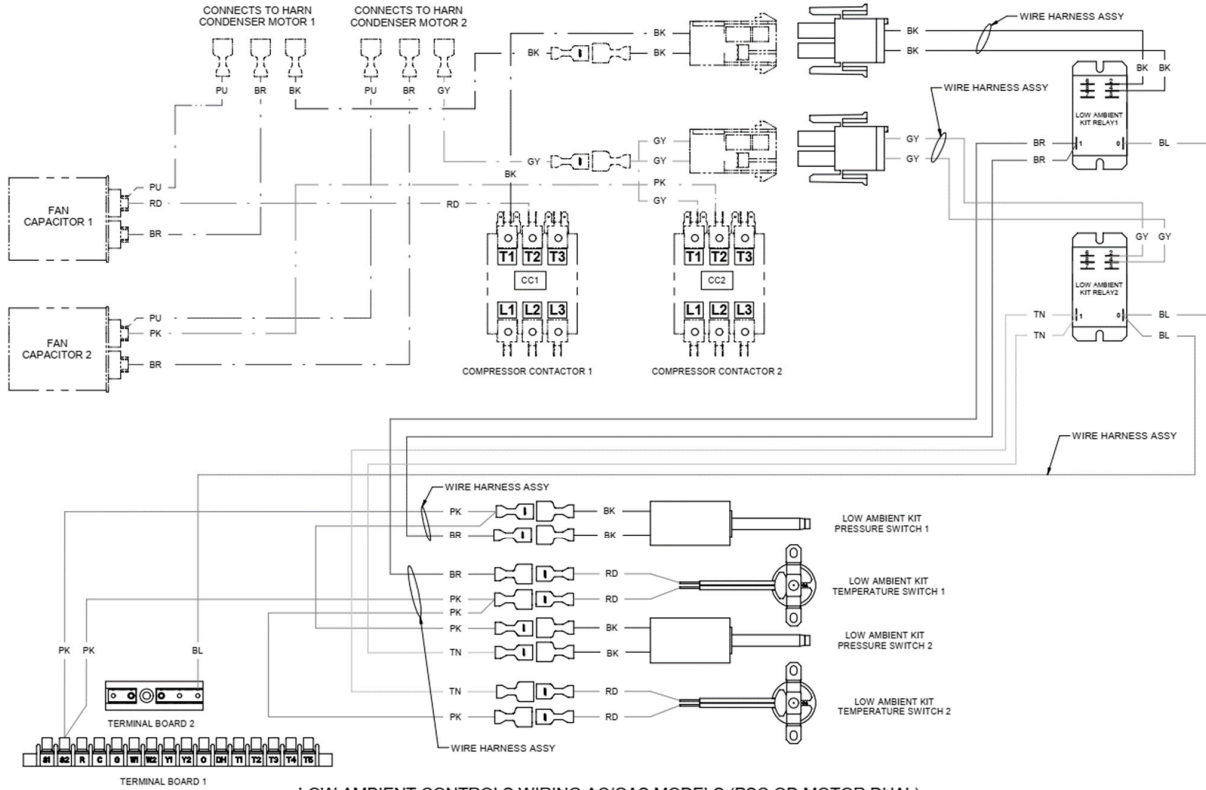
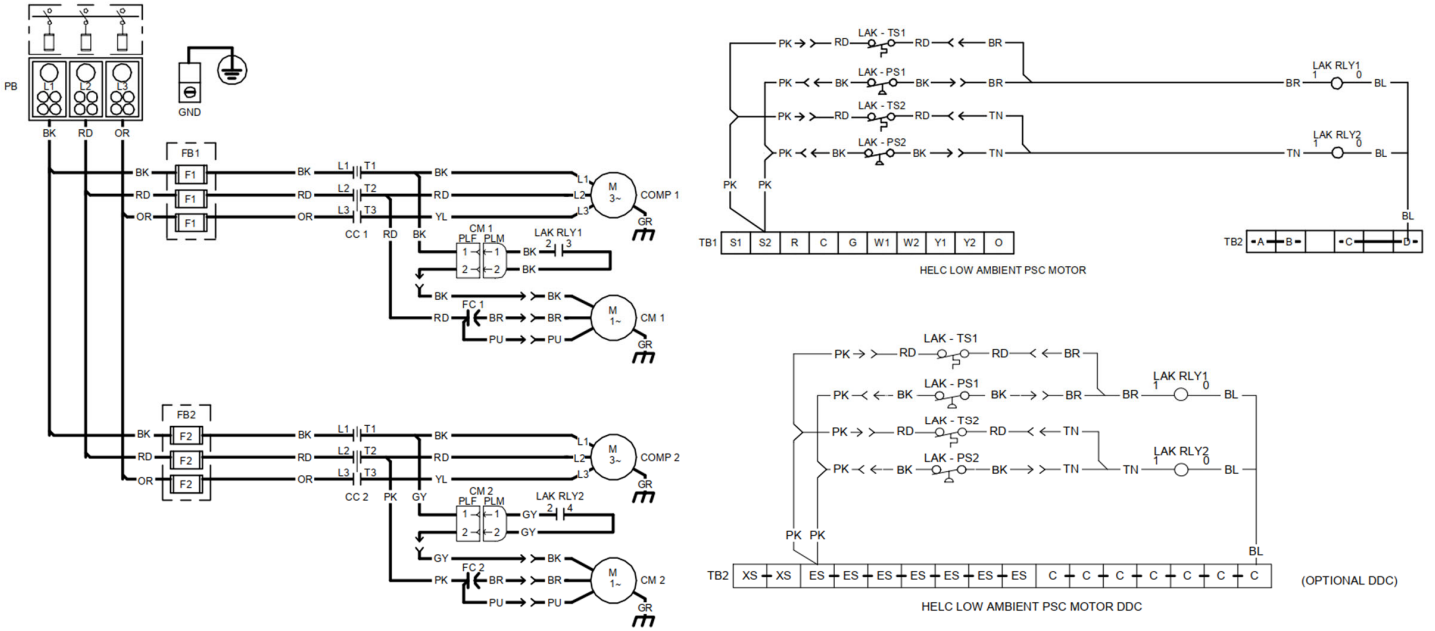

LOW AMBIENT CONTROLS WIRING AC/GAS MODELS (PSC OD MOTOR DUAL)

LACKMD013 & LACKMD017 WIRING DIAGRAM AND ILLUSTRATION

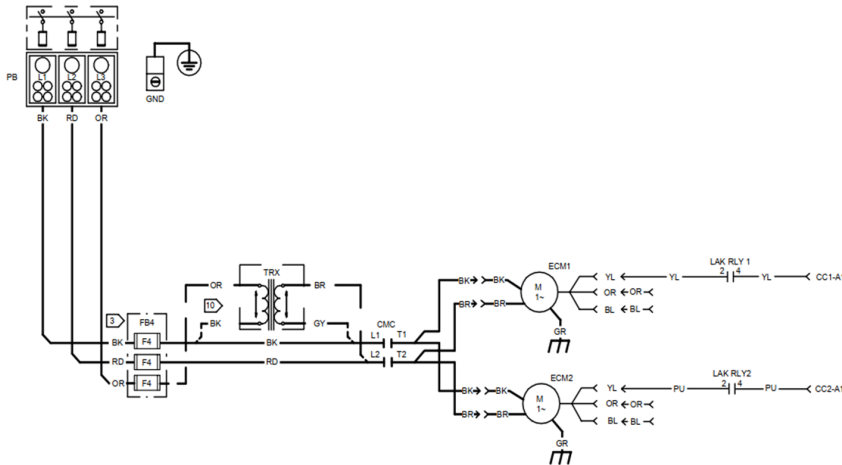

NOTE :

DISCONNECT THE YELLOW 24V SIGNAL CONDENSER MOTOR 1 WIRE FROM COMPRESSOR CONTACTOR CC1-A1 AND RECONNECT TO LAK RLY1 PIN 2. CONNECT YELLOW WIRE FROM NEW HARNESS TO LAK RLY1 PIN 4 AND COMPRESSOR CONTACTOR CC1-A1.

DISCONNECT THE PURPLE 24V SIGNAL CONDENSER MOTOR 2 WIRE FROM COMPRESSOR CONTACTOR CC2-A1 AND RECONNECT TO LAK RLY2 PIN 2. CONNECT PURPLE WIRE FROM NEW HARNESS TO LAK RLY2 PIN 4 AND COMPRESSOR CONTACTOR CC2-A1.

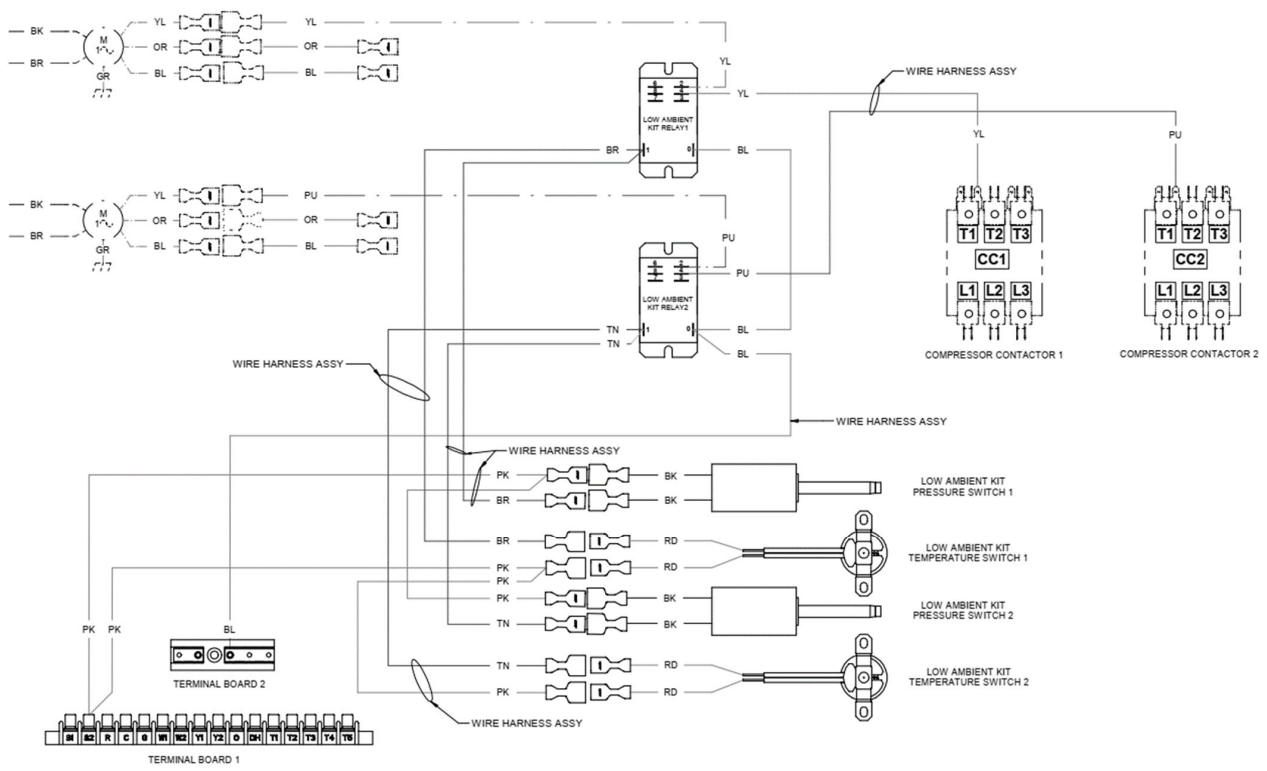
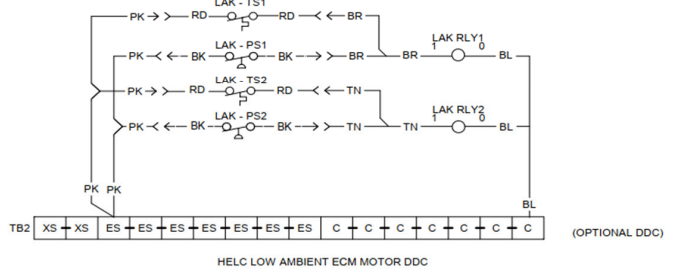
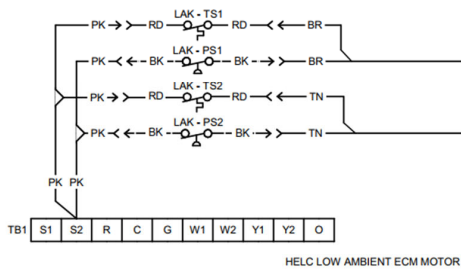

LACKMD020 WIRING DIAGRAM AND ILLUSTRATION FOR DFC/DFG AND DSC/DSG MODELS

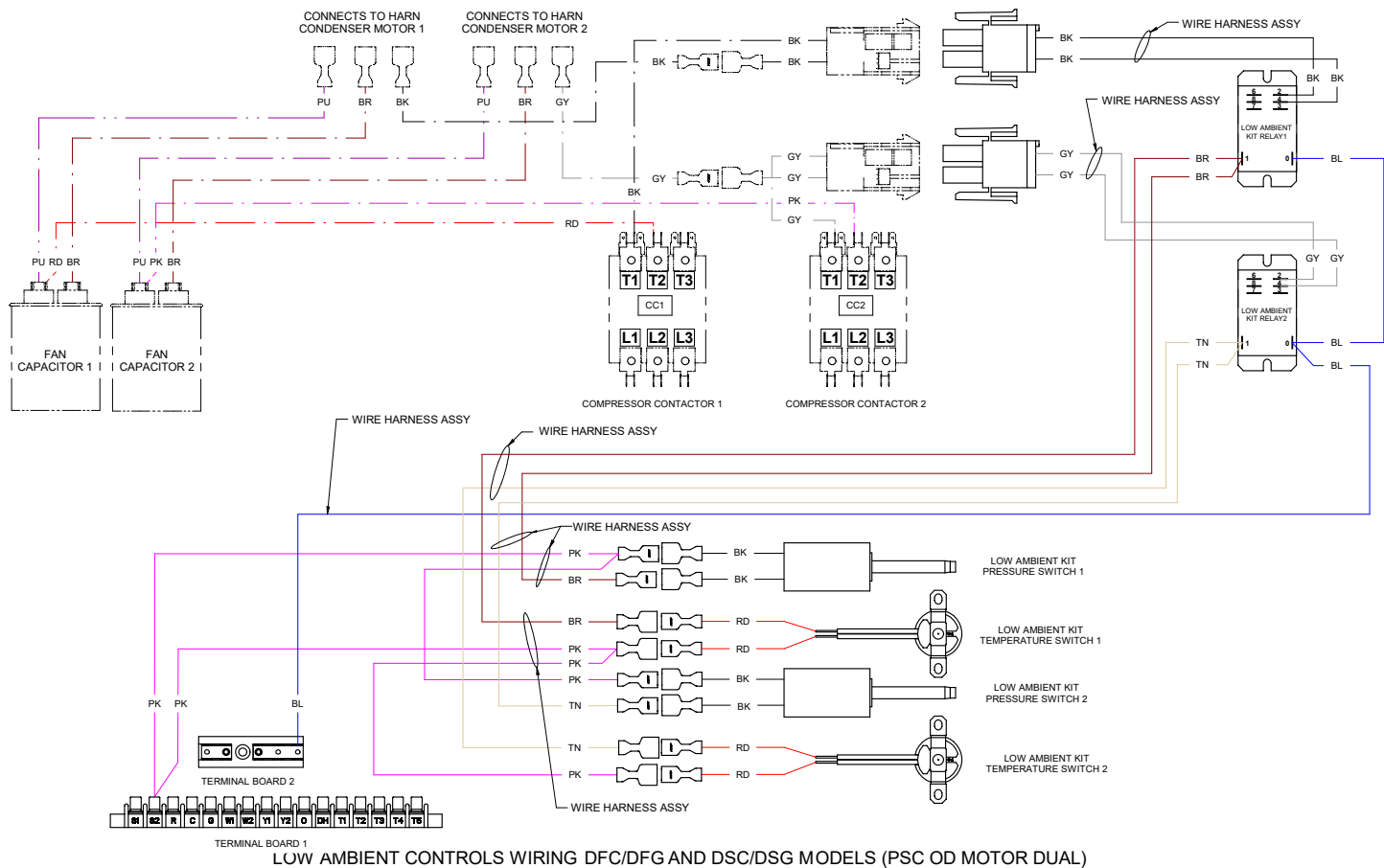
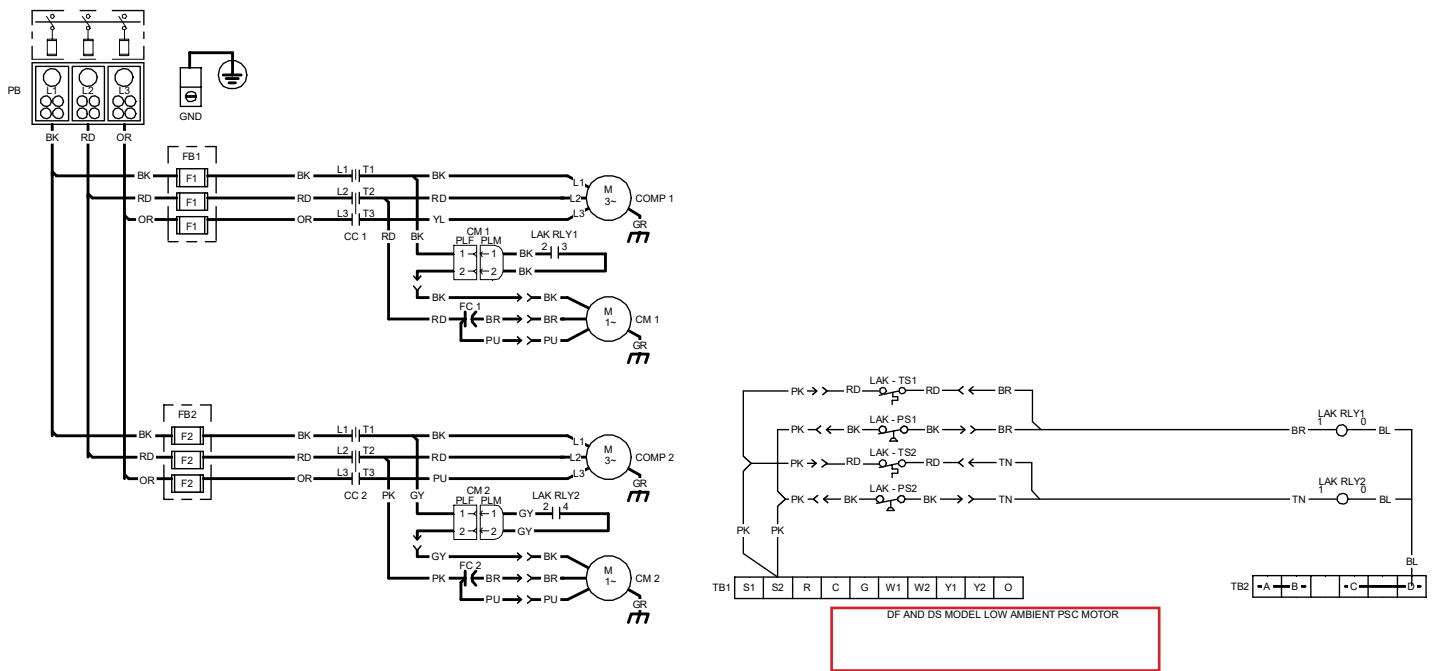

LOW AMBIENT CONTROLS WIRING DFC/DFG AND DSC/DSG MODELS (PSC OD MOTOR DUAL)

LACKMD020 WIRING DIAGRAM AND ILLUSTRATION FOR DFH AND DSH MODELS

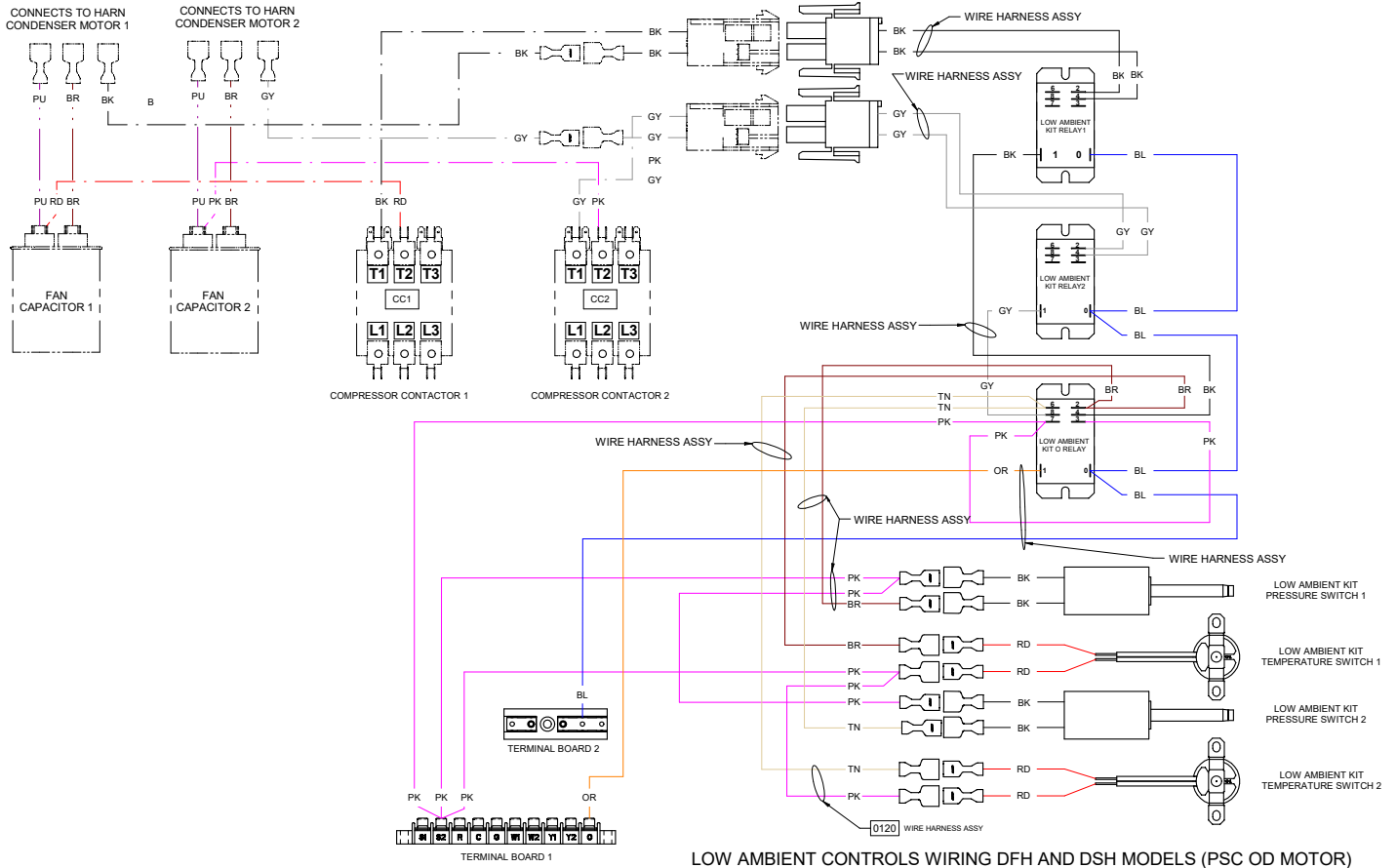
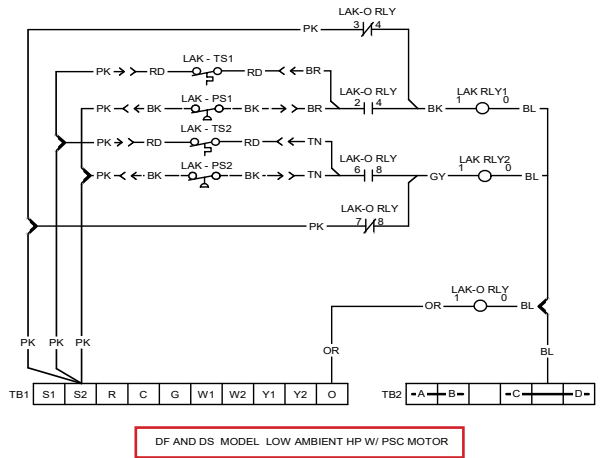
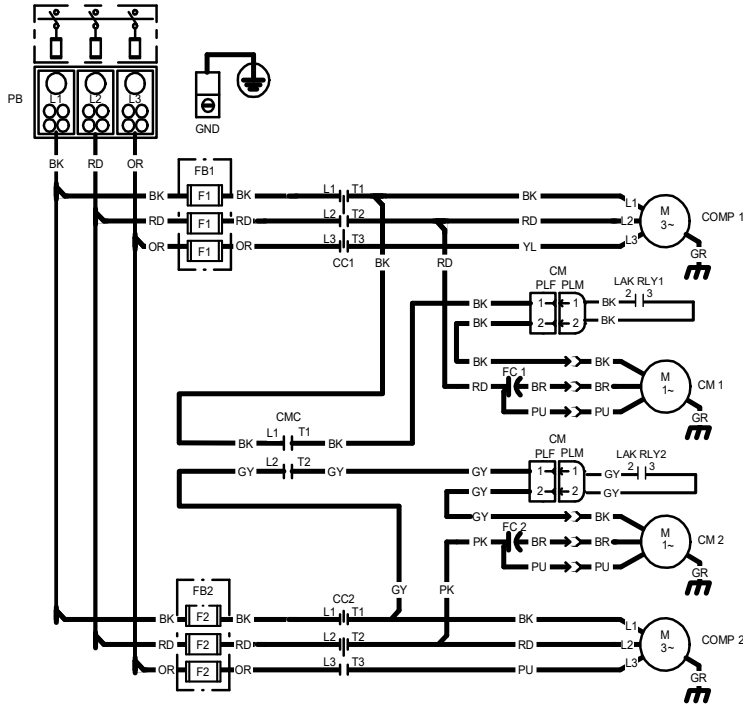

LACKMD020 WIRING DIAGRAM AND ILLUSTRATION FOR DHC/DHG090, DHC/DHG102, DHC/DHG120

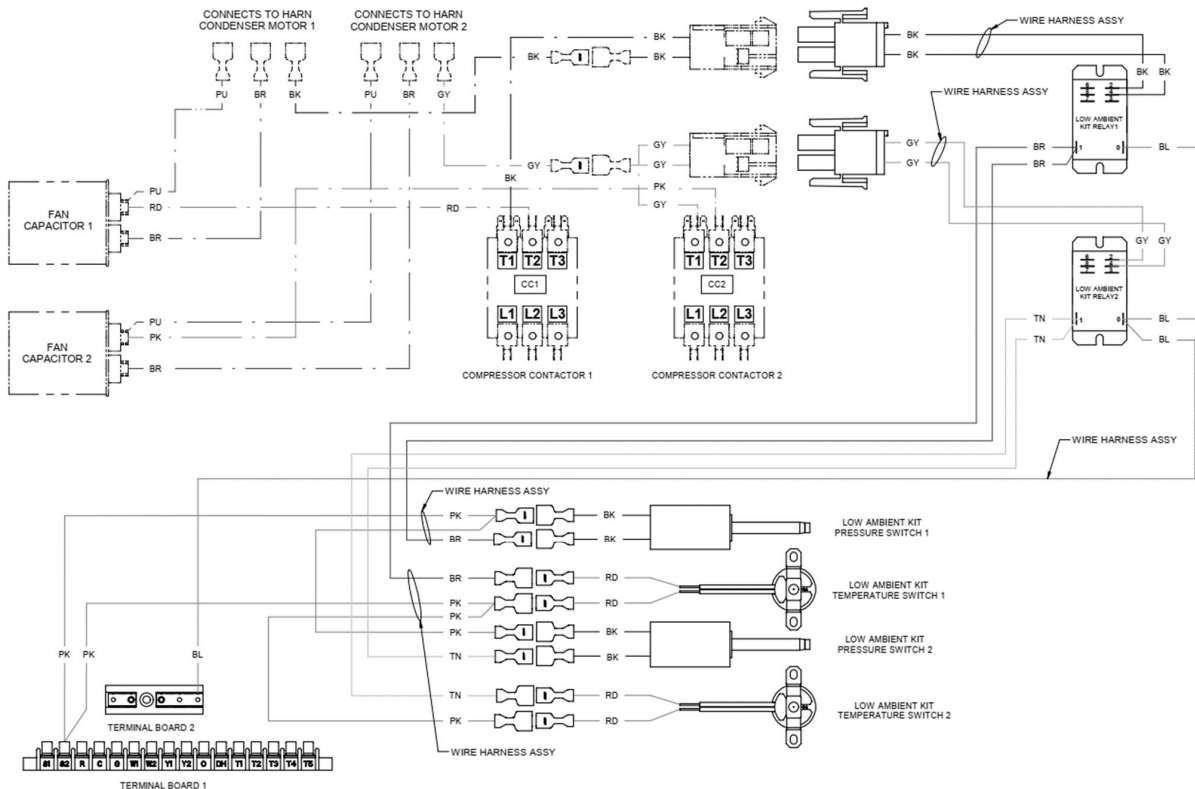
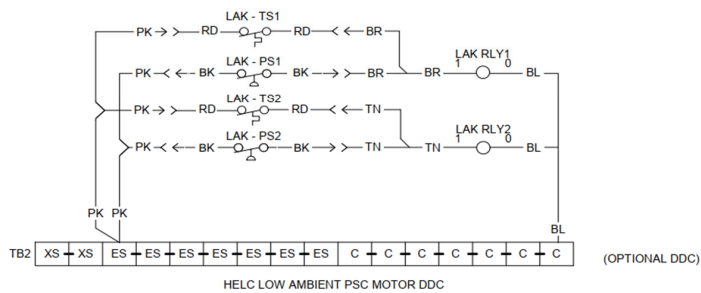
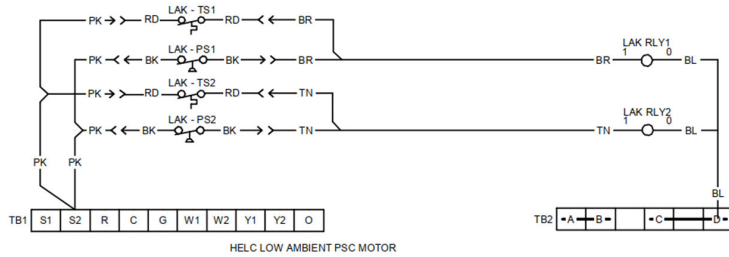
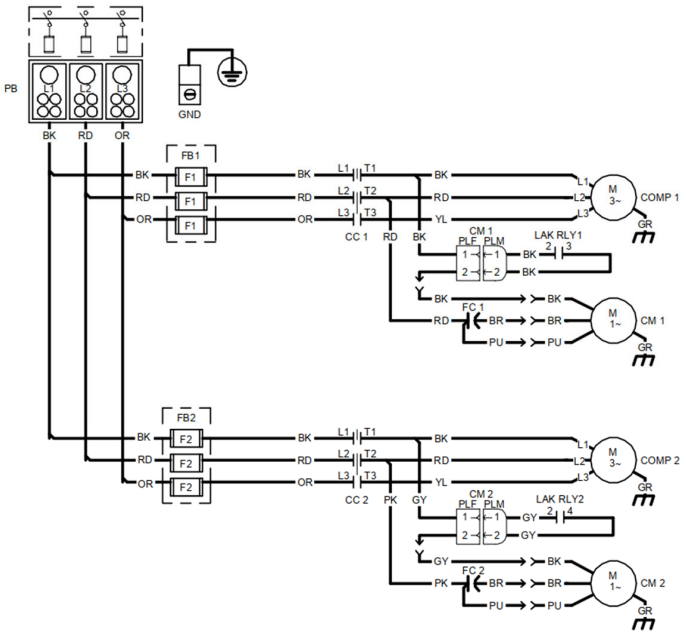

LOW AMBIENT CONTROLS WIRING AC/GAS MODELS (PSC OD MOTOR DUAL)

LACKMD020 WIRING DIAGRAM AND ILLUSTRATION FOR DHC/DHG150

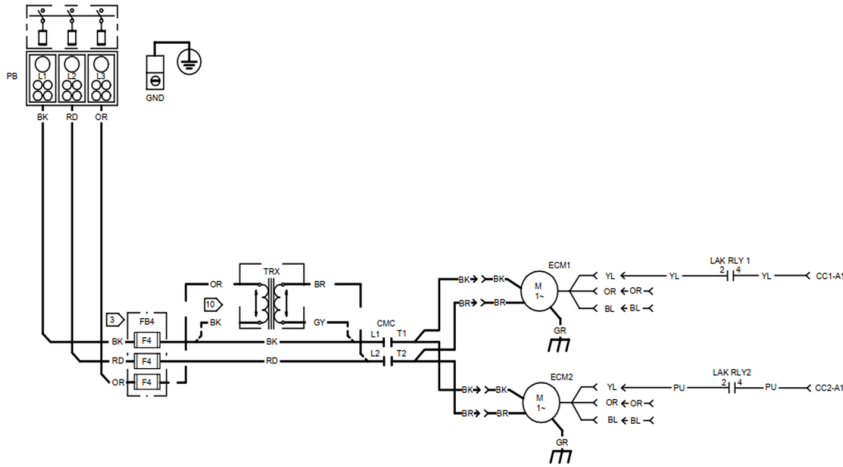

NOTE :

DISCONNECT THE YELLOW 24V SIGNAL CONDENSER MOTOR 1 WIRE FROM COMPRESSOR CONTACTOR CC1-A1 AND RECONNECT TO LAK RLY1 PIN 2. CONNECT YELLOW WIRE FROM NEW HARNESS TO LAK RLY1 PIN 4 AND COMPRESSOR CONTACTOR CC1-A1.

DISCONNECT THE PURPLE 24V SIGNAL CONDENSER MOTOR 2 WIRE FROM COMPRESSOR CONTACTOR CC2-A1 AND RECONNECT TO LAK RLY2 PIN 2. CONNECT PURPLE WIRE FROM NEW HARNESS TO LAK RLY2 PIN 4 AND COMPRESSOR CONTACTOR CC2-A1.

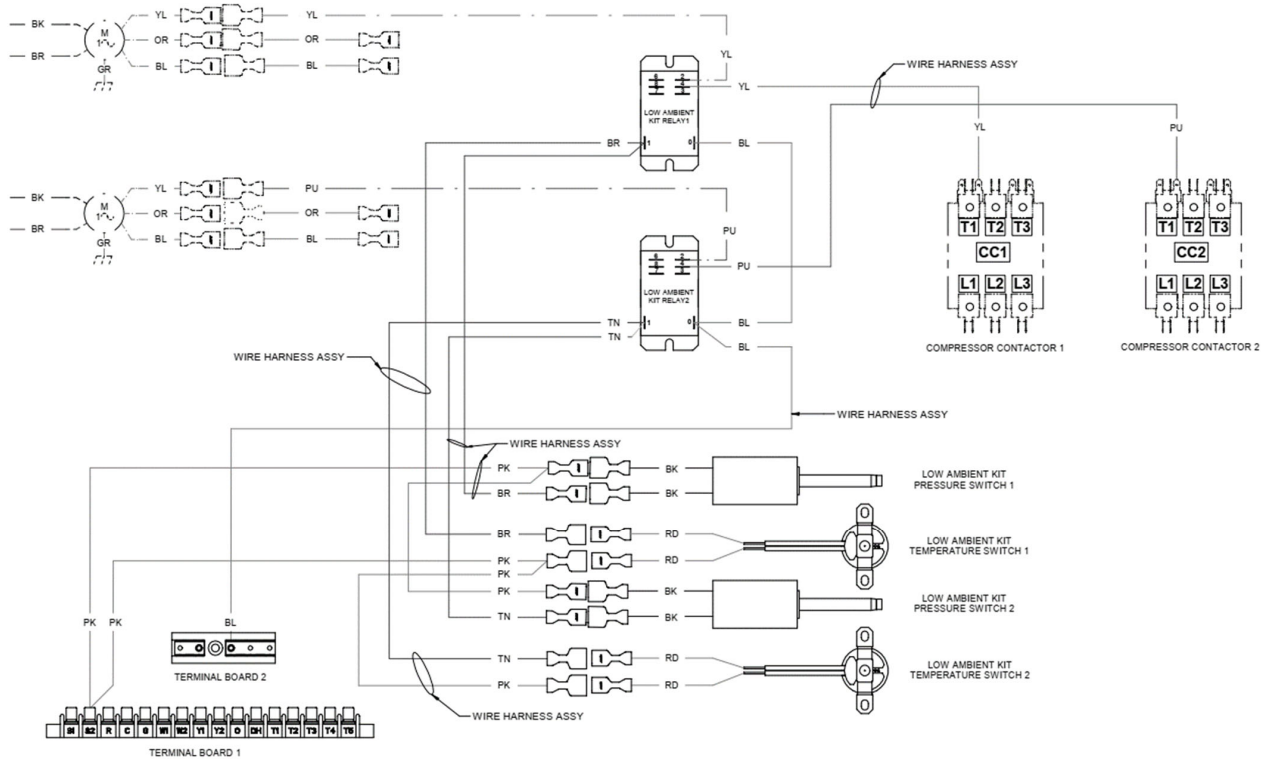
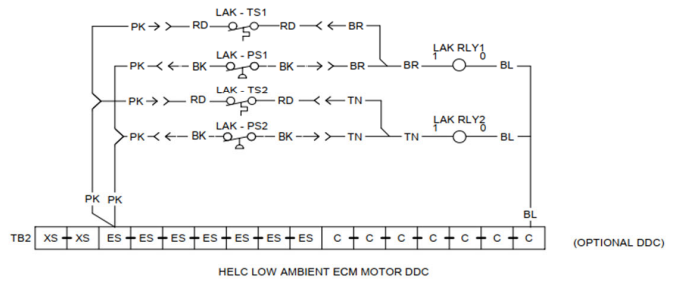
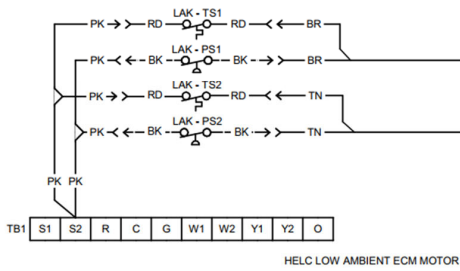

LACKMD021 WIRING DIAGRAM AND ILLUSTRATION DBC/DBG MODELS

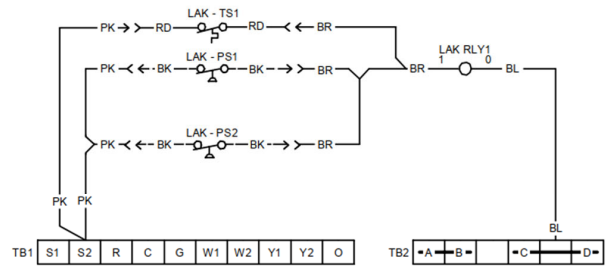
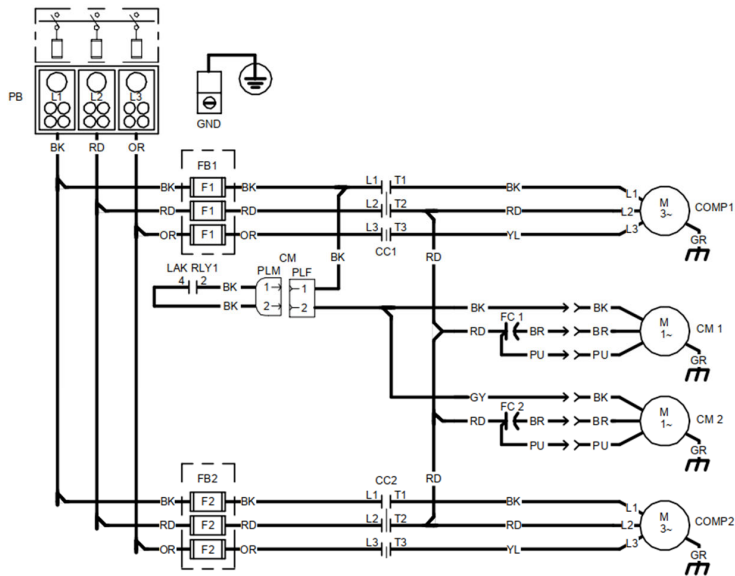

BELC LOW AMBIENT PSC MOTOR

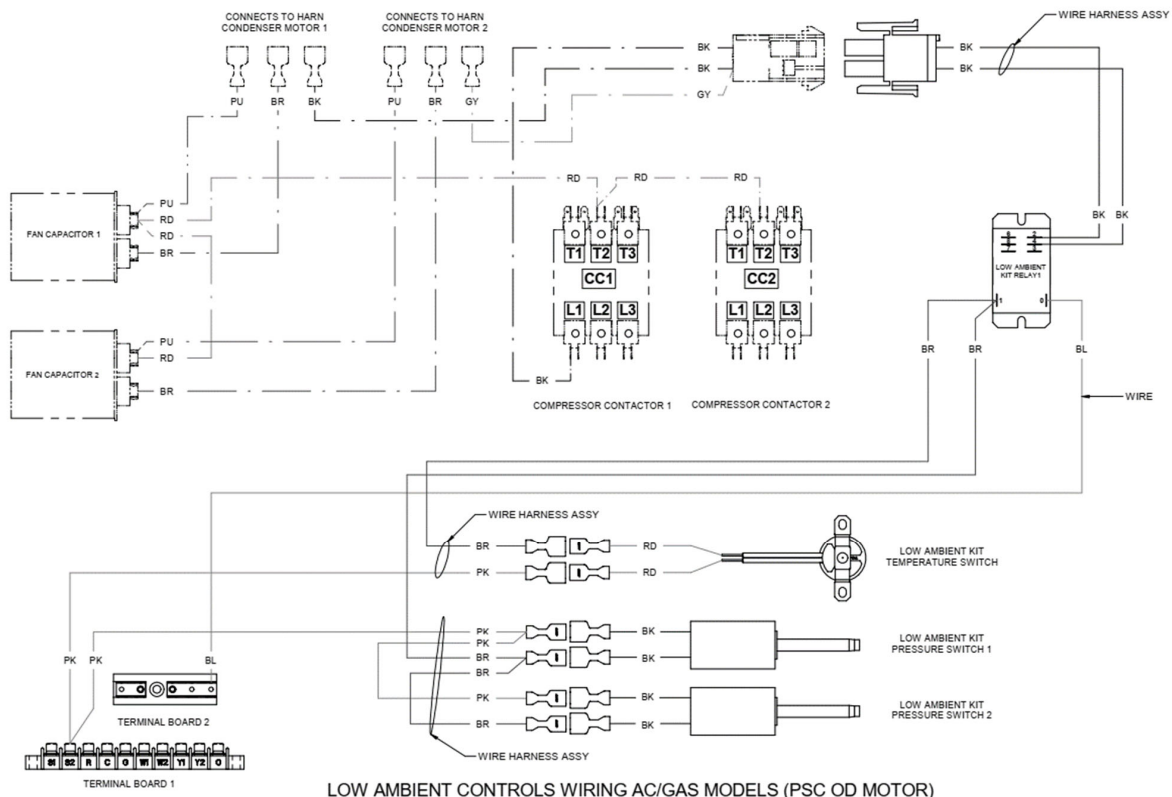

LOW AMBIENT CONTROLS WIRING AC/GAS MODELS (PSC OD MOTOR)

LACKMD021 WIRING DIAGRAM AND ILLUSTRATION FOR DBH 150 MODELS

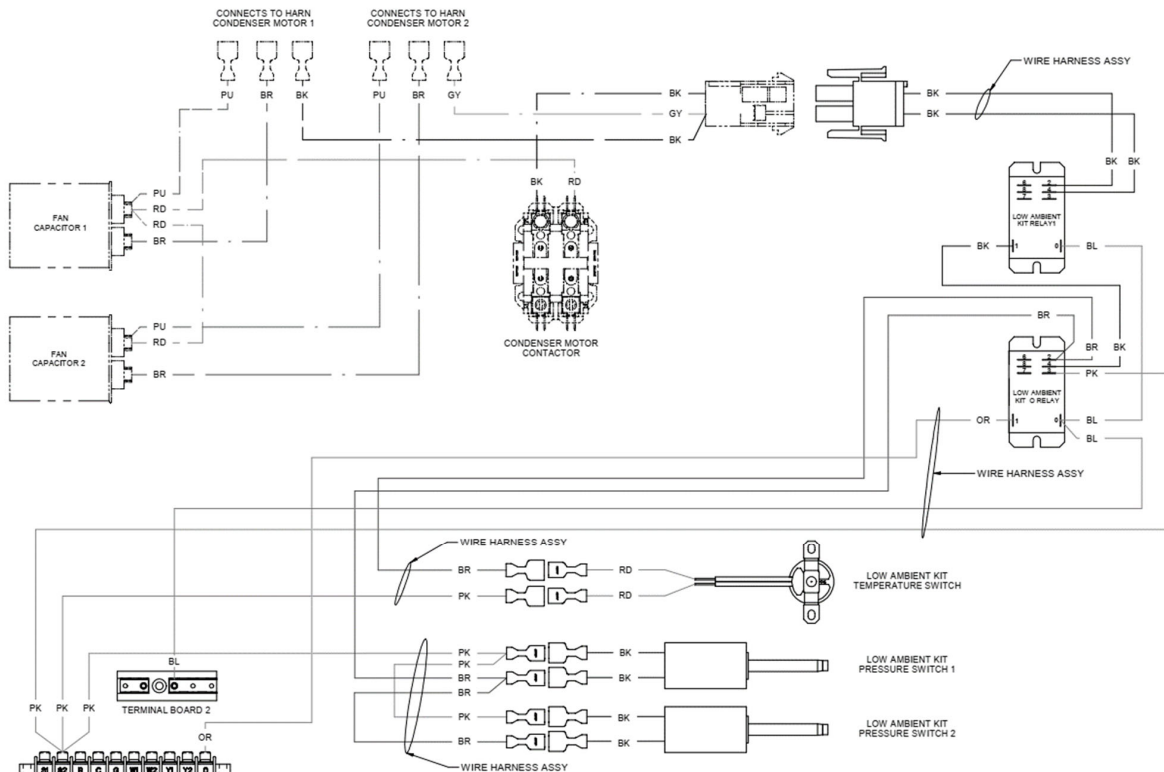
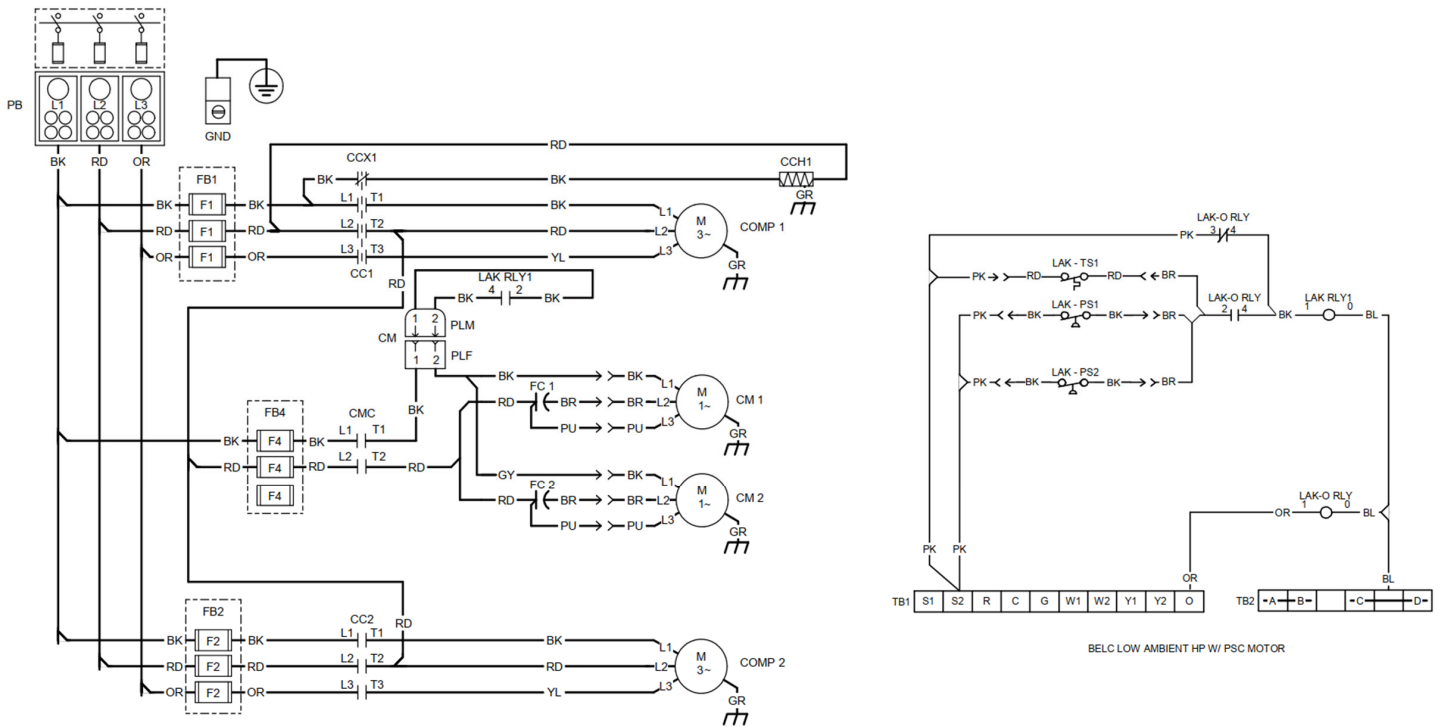

LOW AMBIENT CONTROLS WIRING HP MODELS (PSC OD MOTOR)

LACKLG012 WIRING DIAGRAM AND ILLUSTRATION

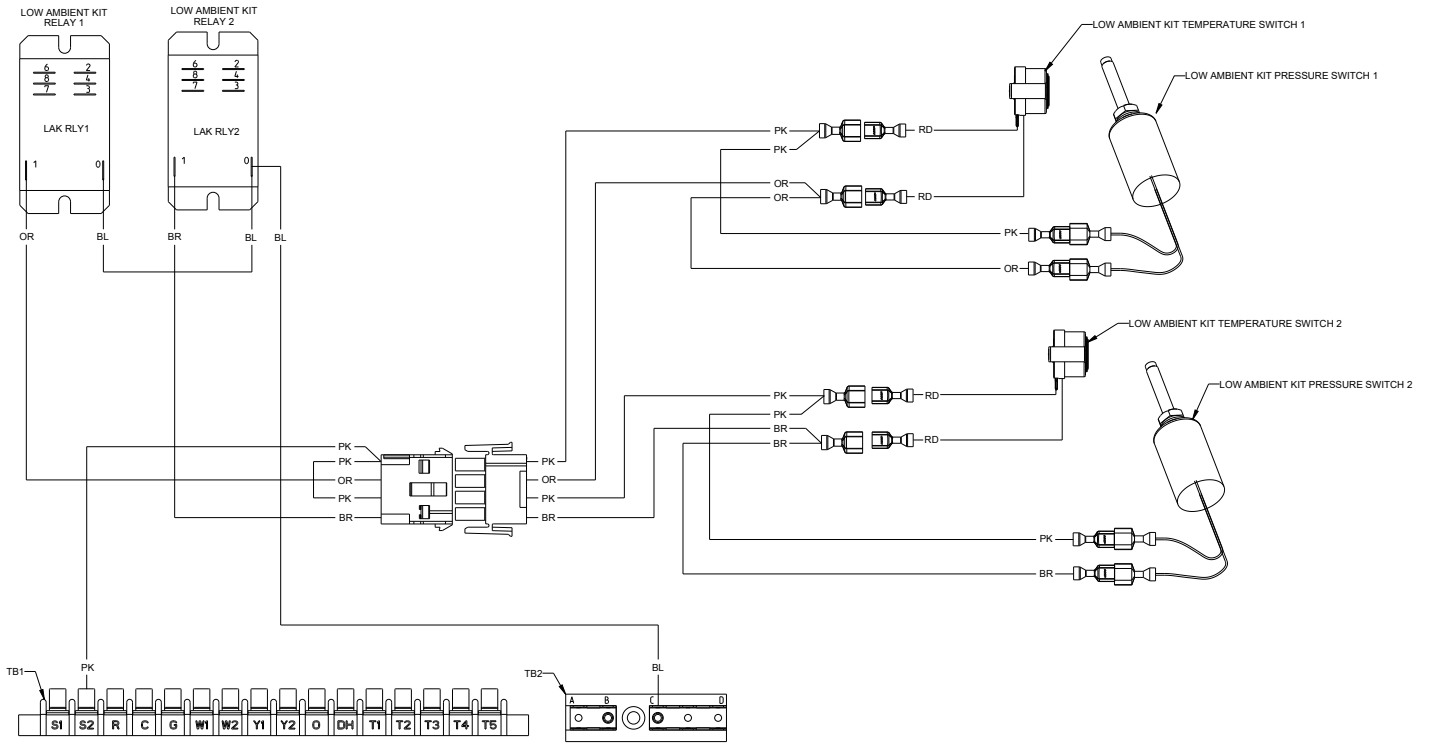
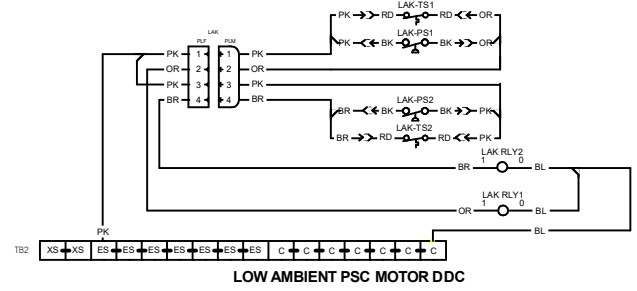
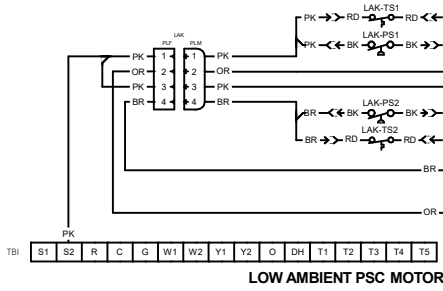
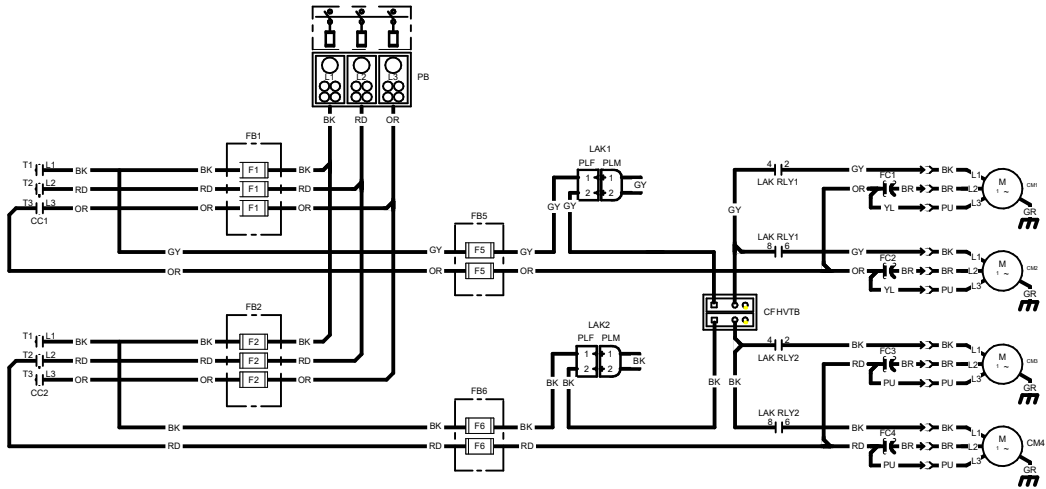

LACKLG012 WIRING DIAGRAM AND ILLUSTRATION (CONTINUED)

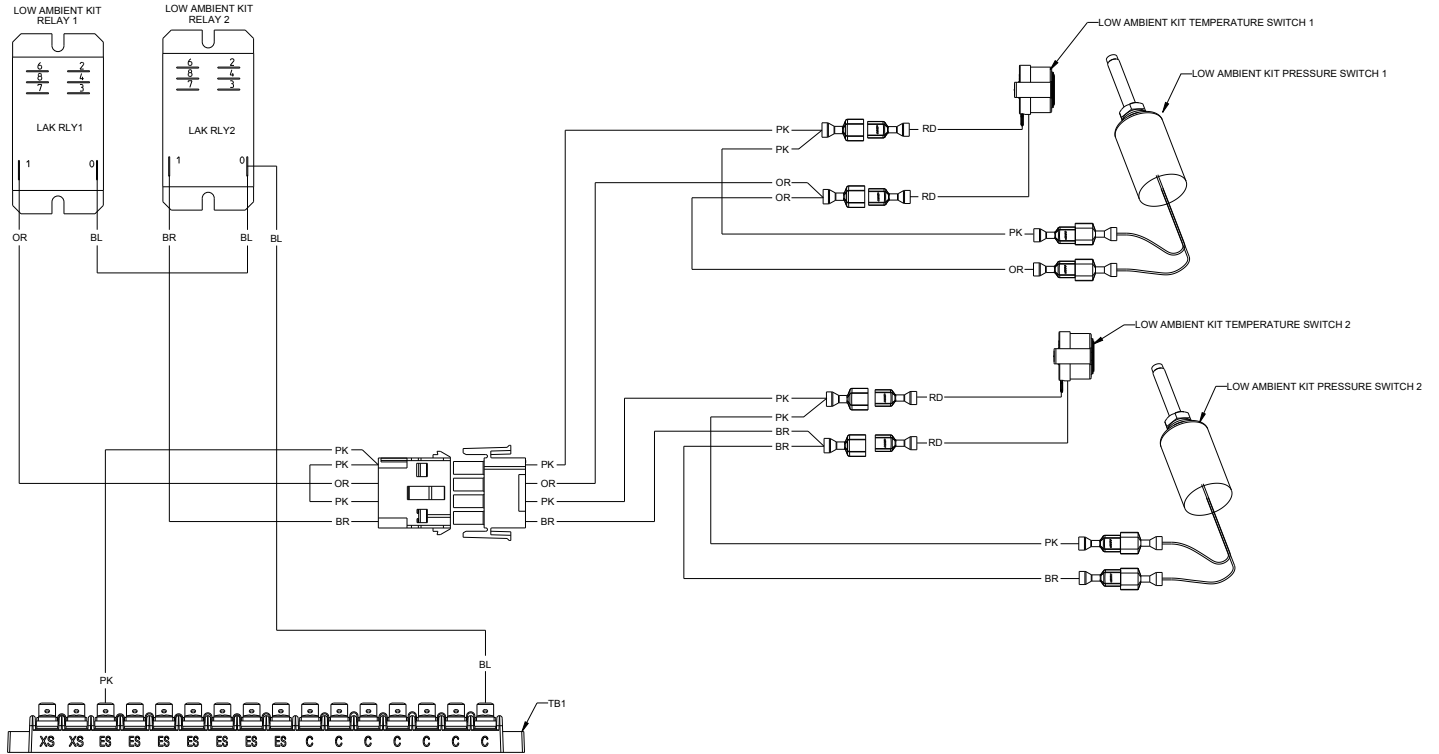

LOW AMBIENT CONTROL HARNESS ROUTING (DDC)

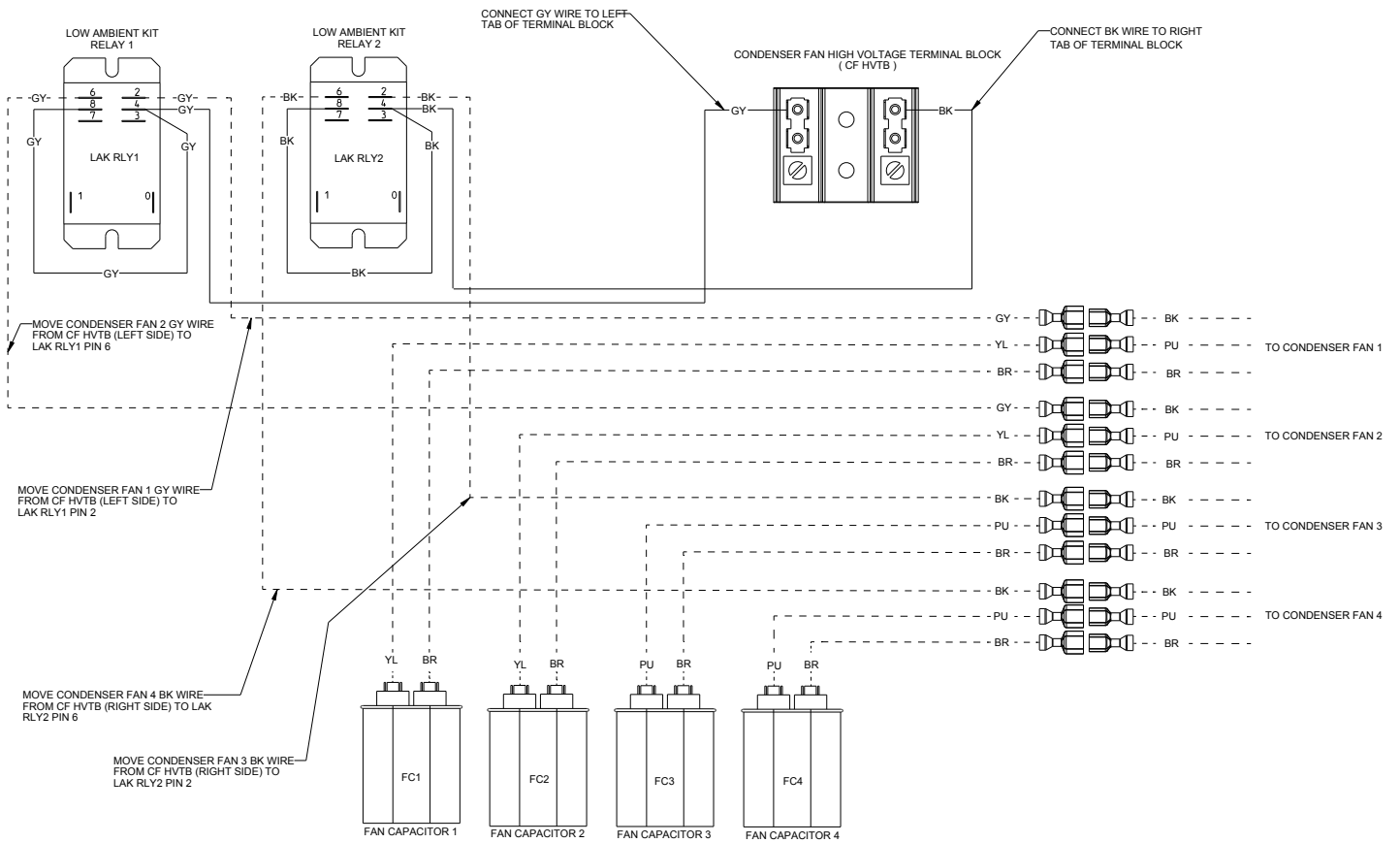

LOW AMBIENT CONTROL HARNESS ROUTING (HIGH VOLTAGE)

LACKLG013 WIRING DIAGRAM AND ILLUSTRATION

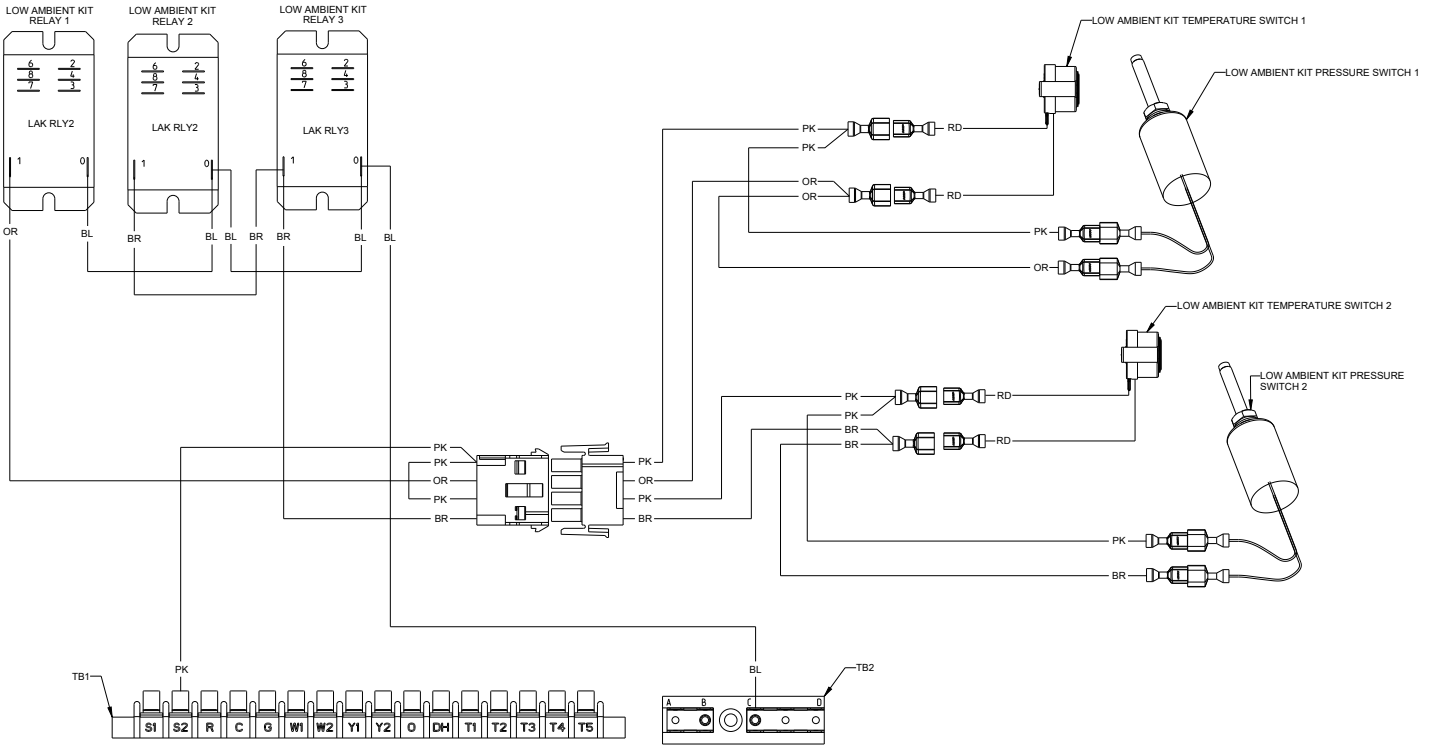

LOW AMBIENT CONTROL HARNESS ROUTING (NON-DDC)

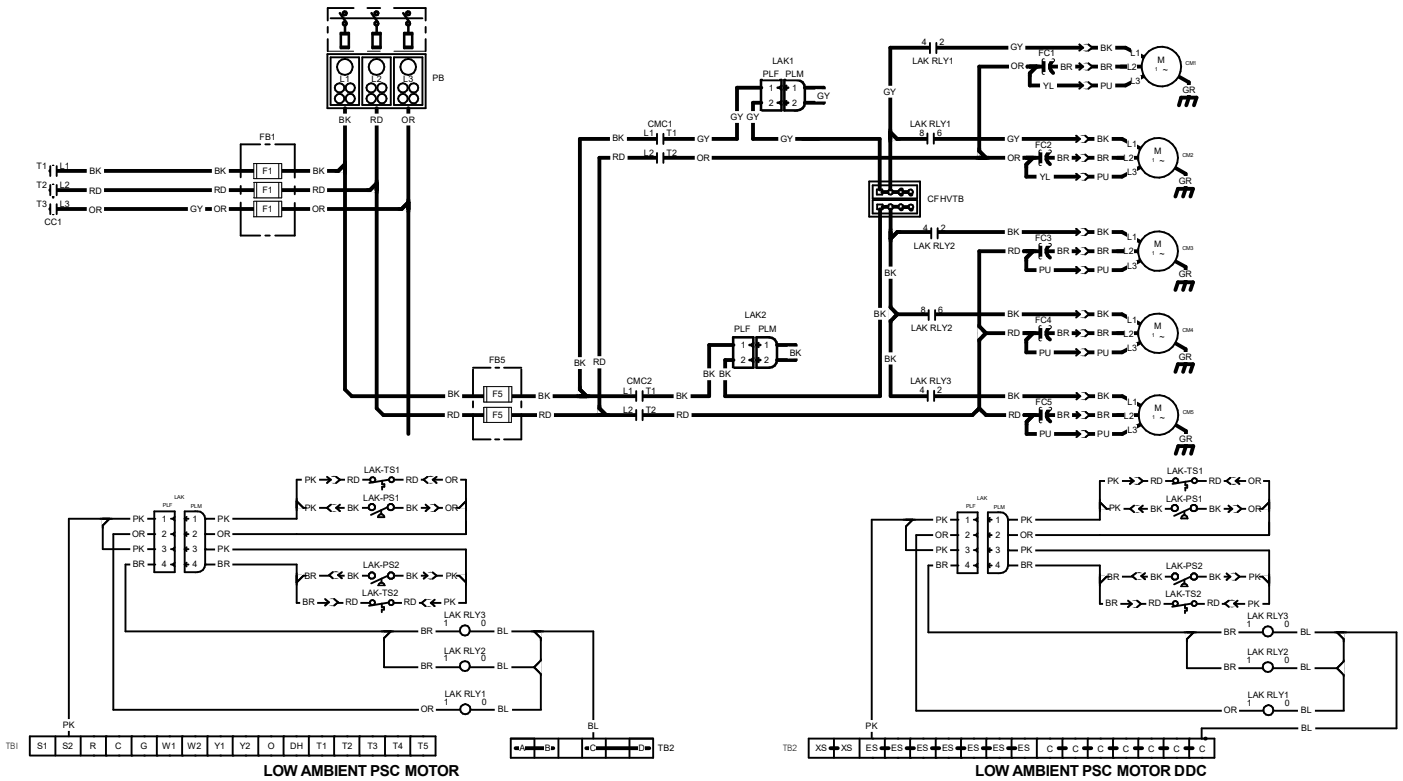

LACKLG013 WIRING DIAGRAM AND ILLUSTRATION (CONTINUED)

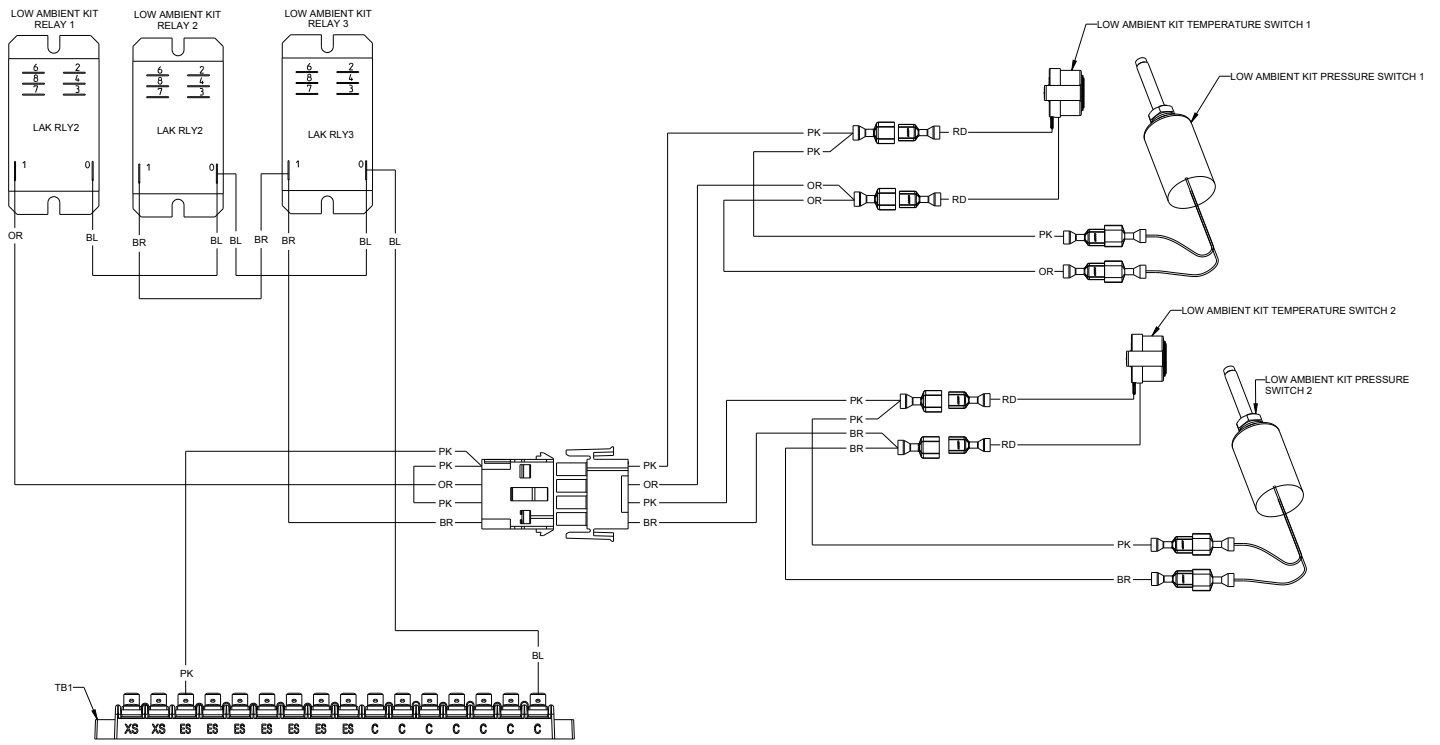

LOW AMBIENT CONTROL HARNESS ROUTING (DDC)

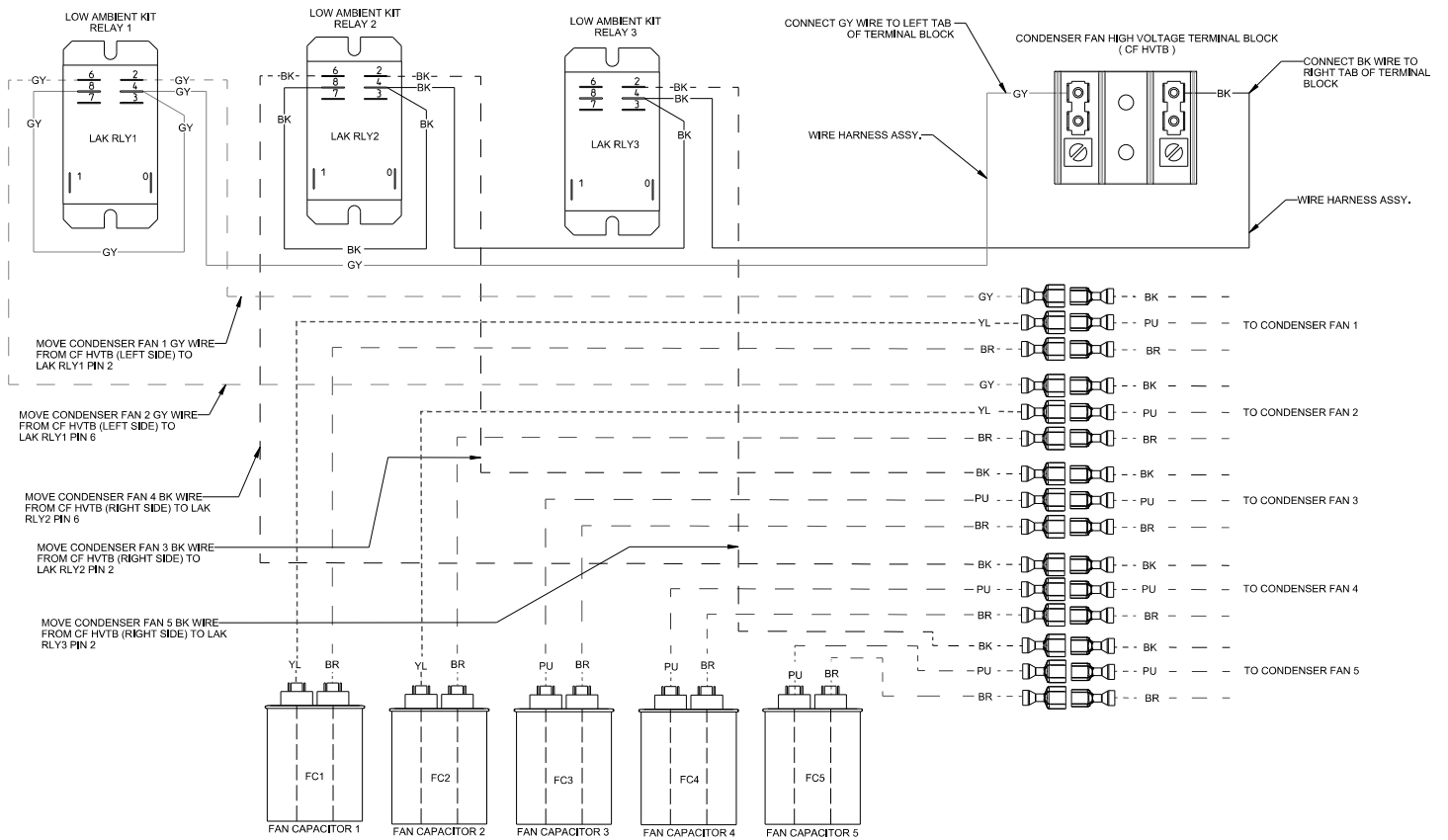

LOW AMBIENT CONTROL HARNESS ROUTING (HIGH VOLTAGE)

LACKLG014 WIRING DIAGRAM AND ILLUSTRATION

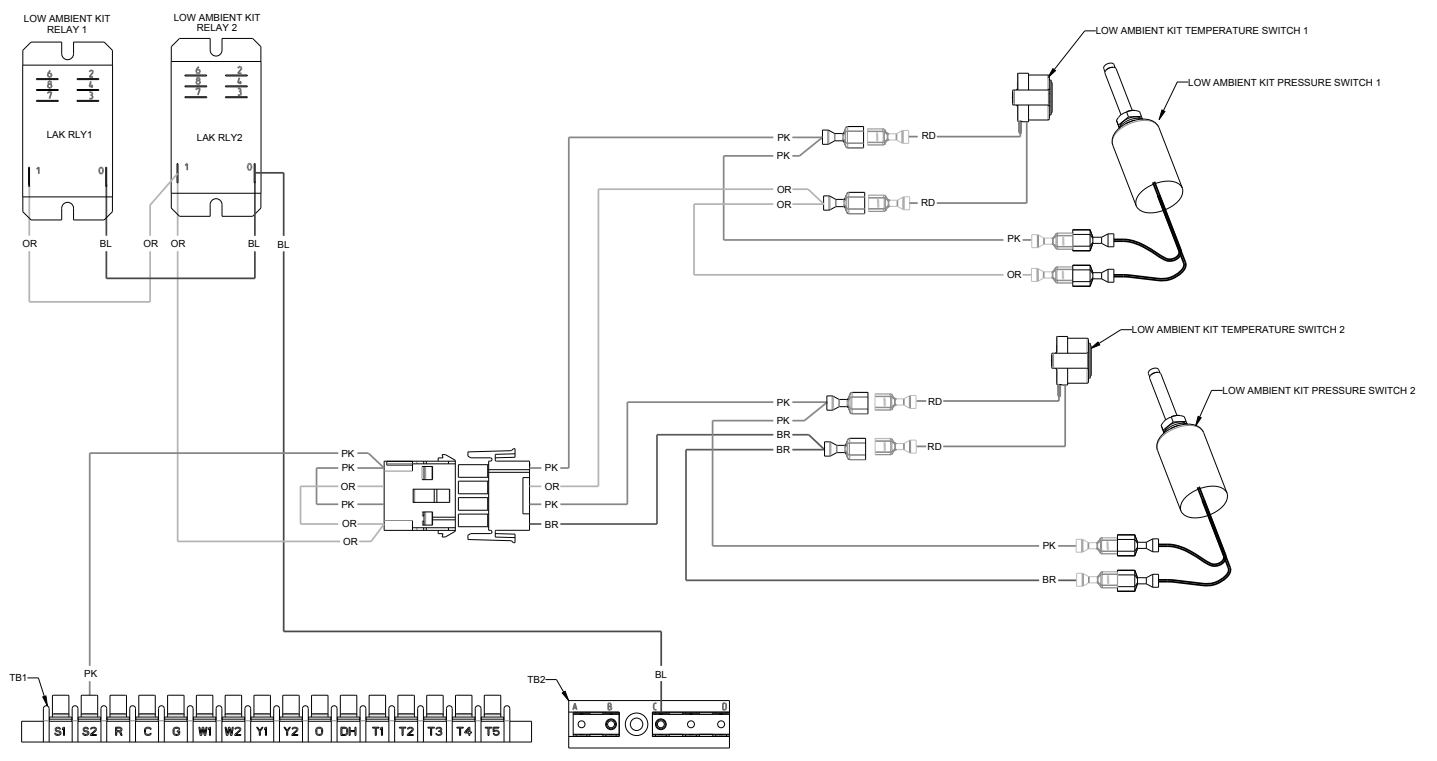
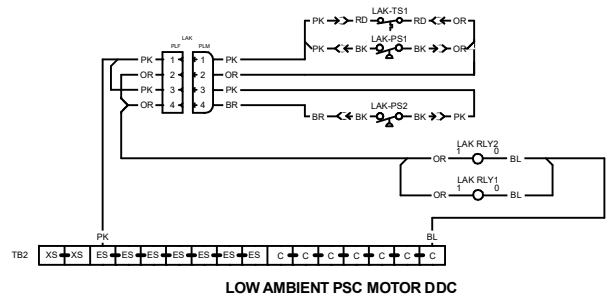
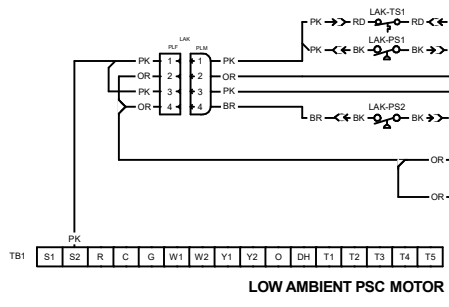
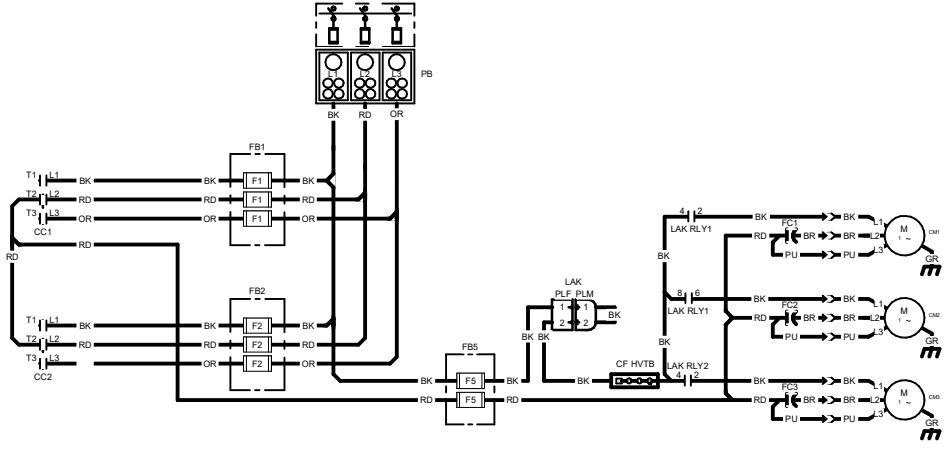

LACKLG014 WIRING DIAGRAM AND ILLUSTRATION (CONTINUED)

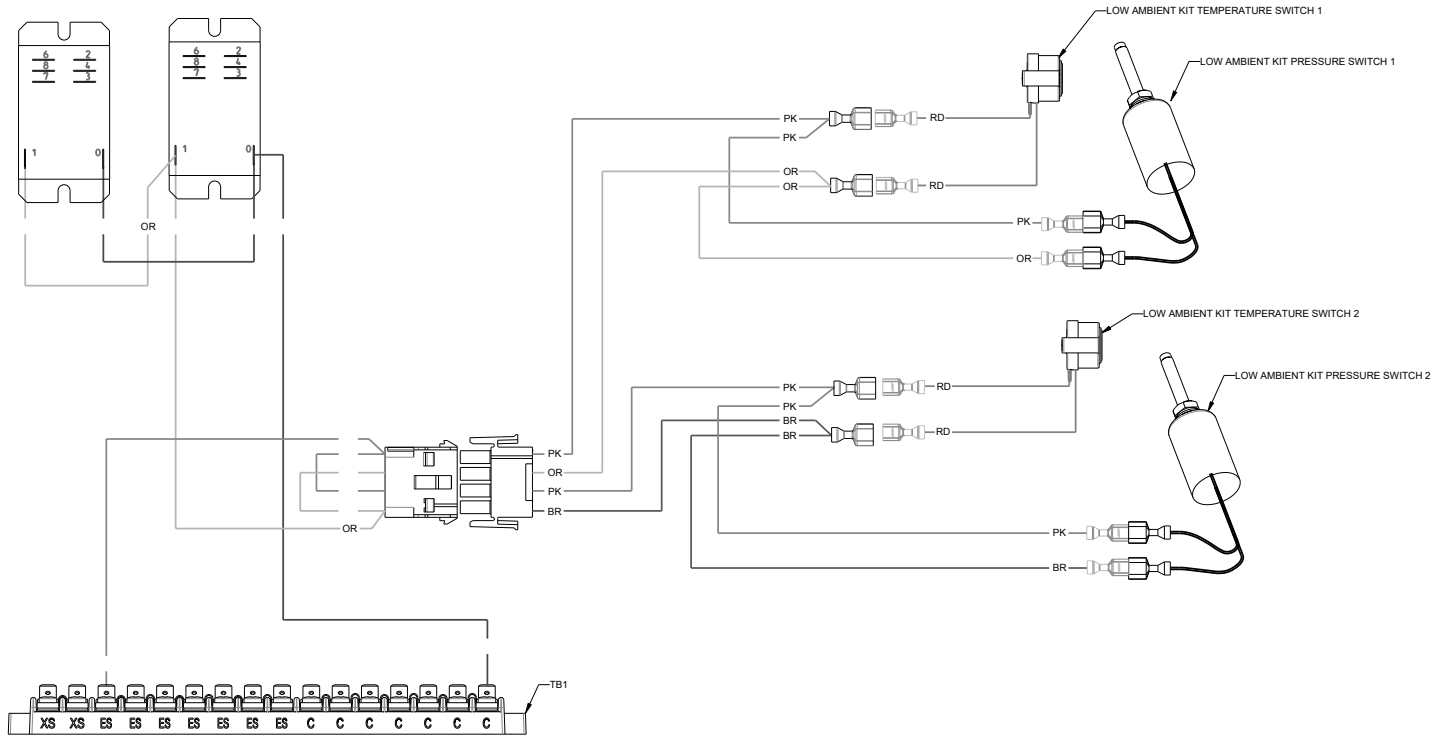

LOW AMBIENT CONTROL HARNESS ROUTING (DDC)

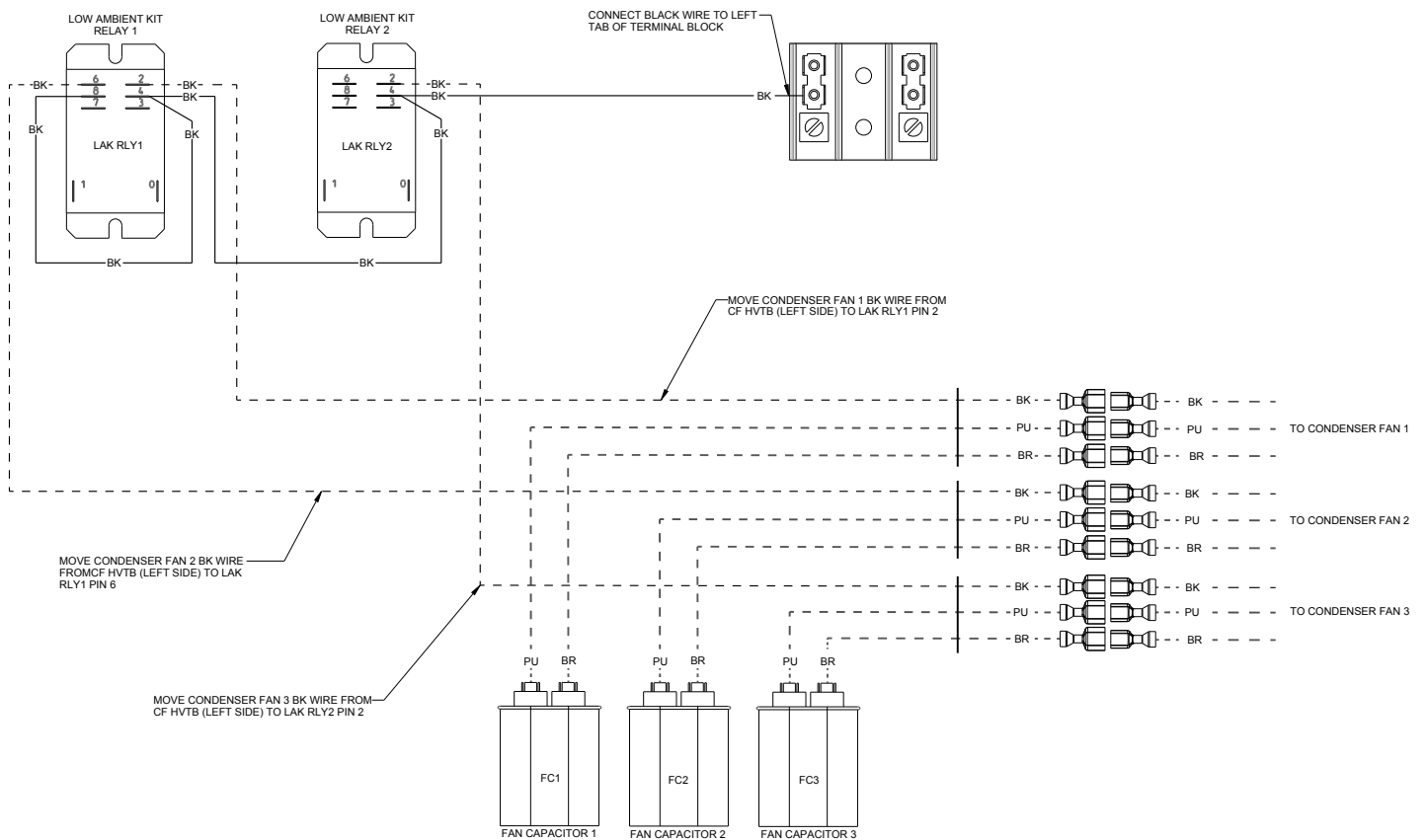

LOW AMBIENT CONTROL HARNESS ROUTING (HIGH VOLTAGE)

THIS PAGE INTENTIONALLY LEFT BLANK

THIS PAGE INTENTIONALLY LEFT BLANK

CUSTOMER FEEDBACK

Daikin is very interested in all product comments.

Please fill out the feedback form on the following link:

<https://daikincomfort.com/contact-us>

You can also scan the QR code on the right to be directed to the feedback page.



Our continuing commitment to quality products may mean a change in specifications without notice.

© 2024 **DAIKIN COMFORT TECHNOLOGIES MANUFACTURING, L.P.**

19001 Kermier Rd., Waller, TX 77484

www.daikincomfort.com