

Daikin Air Conditioner Fresh air intake kit (without duct fan) Installation manual

KDDQ55B140

READ THESE INSTRUCTIONS CAREFULLY BEFORE INSTALLATION.
KEEP THIS MANUAL IN A HANDY PLACE FOR FUTURE REFERENCE.

Caution

Before starting the installation work, carefully read the following, safety precautions and observe them to ensure safety during work.

- Make sure to use the attached or specified components to install the products. Otherwise, it may cause air leak or the product may fall.
- After installation, check whether there is no abnormality during the trial operation.

REMARKS

- This kit can be installed on the ceiling mounted cassette type air conditioner.
- Before installation, confirm the indoor unit name with reference to the left table.
- Please refer to the installation manual for the indoor unit as well as the mounting procedure for the decoration panel during the installation.
- When mounting a duct fan, make sure to use a wiring adapter for electrical appendices (KRPC11) and link it with the indoor unit fan.

Caution

Control the intake air flow volume of the indoor unit so it is 10% or less of fast.
• Be sure to install the attached sensor assy.

<The recommended duct for on-site connection is shown in the table below.>

Part name	Part number	
Flexible duct (Normal diameter $\phi 150$)	K-FDS151D (1m)	K-FDS153D (3m)
	K-FDS152D (2m)	K-FDS154D (4m)

Combination table

Kit name	Applicable indoor unit name and panel name	
	Model	Model
KDDQ55B140	SPLIT	FCQG 71 - 100 - 125 - 140EVEB
	Decoration panel	BYCP125B-W1

Components

Name	① Suction chamber	② Connecting chamber (Left)	③ Connecting chamber (Right)	④ Sealing material	⑤ Desiccant tape	⑥ Screw	⑦ Sensor assy	⑧ Clamp	⑨ Screw (for sensor)	⑩ Installation manual
Shape										
Quantity	1 pc.	1 pc.	1 pc.	2 pcs.	2 pcs.	4 pcs.	1 pc.	2 pcs.	1 pc.	1 pc.

1 Selection of location and access door

(1) Refer to the following figure to select the mounting position (unit: mm).

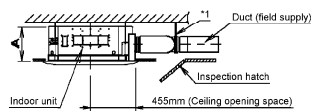

(2) Install the inspection batch (unit: mm).

Indoor unit	SPLIT	A (mm)
BYCP125B-W1	71~140 type	348

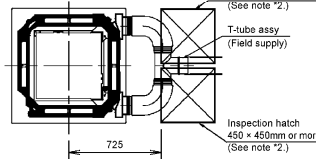

1. Hang and fix the T-tube assy for installation. The load of the T-tube assy may create a clearance between the indoor unit and suction chamber.
2. Install the inspection batch (450 x 450mm or more). Either one of the inspection batches must be installed.

2 Installation of sensor assy and suction chamber

*When the indoor unit is already installed, perform the following operations in accordance with the precautions below.
• Make sure to turn off the power supply before starting the operation.
• Remove the decoration panel from the indoor unit. (For details, please refer to the installation manual provided with the decoration panel.)

<Installation of sensor assy>

- 1) Refer to the installation manual of the indoor unit, remove the control box lid of indoor unit.
- 2) Install the sensor assy and bell mouth on the indoor unit using the provided screws.
- 3) Remove the connector (X16A) of the existing sensor from the printed circuit board of the indoor unit, and the connector (X4A) of the existing sensor from the printed circuit board of the adapter.
- 4) Connect the wire harness of the sensor assy that was attached to the indoor unit to the connector (X16A) on the printed circuit board of the indoor unit and the connector (X4A) on the printed circuit board of the adapter as shown in the figure below.
- 5) Use the provided clamps to fix the wire harness (to the other wire harness) as shown in the right figure.
- 6) When all wiring operations are completed, install the control box lid in accordance with the installation manual provided with the air conditioner.

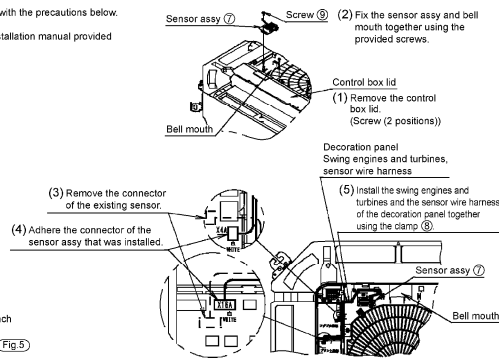

<Installation of suction chamber>

- *The figure shows the installation procedure for a new indoor unit.
- 1) Adhere the desiccant tape ⑤ to the corner air outlet sealing material ④, and then attach them to the air outlet of the indoor unit. (2 positions) (Fig.1) (Fig.2)
 - 2) Install the suction chamber ① on the indoor unit using hooks (4 positions) (Fig.3) ~ (Fig.5). Fix the hooks at the four positions with reference to (Fig.4).
- *Install the indoor unit and suction chamber while aligning their contours. (Fig.4) (Fig.6)

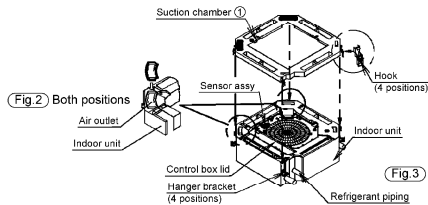

(Fig.1) Air outlet ④, ⑤

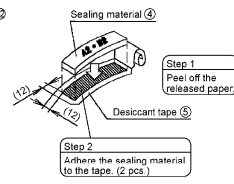

Step 1 Peel off the released paper.

Step 2 Adhere the sealing material to the tape. (2 pcs.)

3 Installation of indoor unit and suction chamber

- Install the indoor unit and suction chamber. For installation, follow the installation manual provided with the indoor unit. (Please refer to the right figure for the installation height.)
- To install the suction chamber on an existing indoor unit, change the installation height of the indoor unit to A in the right figure.

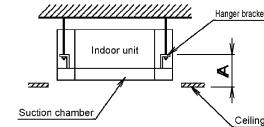

	A (mm)
BYCP125B-W1	185

4 Installation of connecting chamber and connection of flexible duct

Install the connecting chambers. (One chamber on both sides, 2 in total) (Fig.7)

- 1) Push up the square holes of the connecting chamber ② or ③ while fitting them onto the hook (tab) of the suction chamber ① (2 positions).
- 2) Fix the connecting chamber using the screws ⑥ provided. (2 positions)

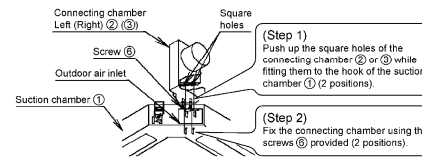

(Step 1) Push up the square holes of the connecting chamber ② or ③ while fitting them to the hook of the suction chamber ① (2 positions).

(Step 2) Fix the connecting chamber using the screws ⑥ provided (2 positions).

(Fig.7) Installation of connecting chamber (this figure shows the left connecting chamber ②.)

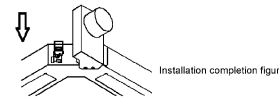

5 Duct connection <Duct: diameter $\phi 150$ >

- 1) Connect duct to the connecting chamber. (Insert duct to the end of the connecting chamber's tube portion.)
- 2) Tie the connected portions with band and wrap with tape to prevent air leak.
- 3) Insulate the duct to prevent condensate.
- 4) Hang and fix the portion of a T-tube. Otherwise, an opening is made by the dignity of a pipe between an indoor unit and suction chamber.

Do not perform the following duct work

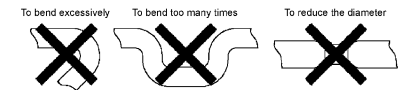

Caution

- Follow the local code or regulation to install the duct.
- In case that metal duct is penetrated through wooden wall, make sure the duct and the wall are electrically insulated.
- At the outdoor side, install the duct inclined downwardly so that the rain will not get into the duct. (Inclination 1/100~1/50)
- Where it contact the outside air, make sure to install screen to avoid birds, small animals or insects getting inside the duct.
- Where it contact the outside air, make sure to install air filter to protect heat exchanger for indoor unit.

6 Installation of decoration panel and suction chamber

- After the decoration panel is installed temporarily, install the harness running from the decoration panel through the hole for the electric wiring of the suction chamber.
- One wire harness for the swing engines and turbines and one wire harness for the sensor (two wire harnesses in total)
- Install the decoration panel in accordance with the installation manual provided with the decoration panel. (Remove the control box lid.)

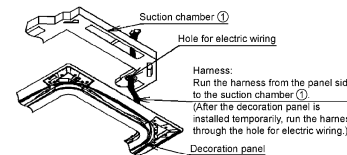

• After the wire harness is installed, install the control box lid. During installation, be careful the wiring is not caught.

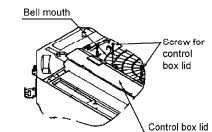

Wireless air conditioners

- For details of the connection procedure, please refer to the installation manual provided with the wireless remote controller kit (provided separately)