



S25(M)FD180300

MANUAL/MOTORIZED 25% FRESH
AIR DAMPER FITS DAIKIN
D*G180-300 AND D*C180-300
SANDSTONE BEIGE

APPLICATION

Most building codes require a certain amount of fresh air to overcome the effects of CO2 during times when the space is occupied. Use of fresh air dampers on HVAC equipment is an inexpensive way to allow fresh air into the building. McDaniel Metals offers both a manual and motorized fresh air damper to fit Daikin light commercial packaged equipment. The manual fresh air damper is installed and fixed in place to allow a certain amount of fresh air to circulate at all times. The motorized fresh air damper includes a small two position actuator that opens the damper when the indoor blower is running and closes the damper when the blower turns off.

MANUAL FRESH AIR DAMPER INSTALLATION S25FD180300

1. Remove the damper assembly from its container and inspect for damage or shortages
2. Locate and remove the evaporator access panel. Retain the screws for step 3.
3. Attach the damper to the side of the machine using the screws from step 2 and weatherproof with silicone or other approved sealant.
4. Remove Filter Access Panel and filter. (Figure 1)
5. Locate the 5/16 set screws at the bottom of the slide dampers and loosen them.
6. Slide the dampers down until the dampers are positioned to provide the correct amount of fresh air and re-attach Filter Access Panel.
7. Tighten the set screws.

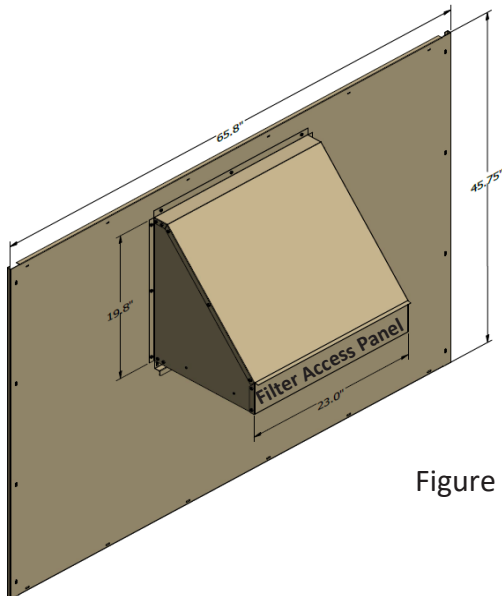

Figure 1

MOTORIZED FRESH AIR DAMPER INSTALLATION S25MFD180300

1. Remove the damper assembly from its container and inspect for damage or shortages.
2. Remove the large evaporator access panel.
3. See the instructions for the S25FD180300 for mounting the damper hood and setting the opening.
4. Remove the jumper plug from the economizer wiring harness and plug in the damper. (Note: It is a good idea to retain the jumper plug for emergencies.)

DETERMINING DAMPER SET POINT

While it is possible to estimate the amount of fresh air by visually adjusting the manual fresh air damper, a more accurate determination can be made using a digital thermometer and the equation below.

$$(To \times OA) + (Tr \times RA) = Tm$$

To = Outdoor air temperature
OA= Percent of outdoor air
Tr = Return air temperature
RA= Percent of return air
Tm= Resulting mixed air temperature

Example:

Fresh air required is 10% outdoor air.
Outdoor air temperature is 60 degrees F.
Return air temperature is 75 degrees F.
 $(0.1 \times 60) + (0.9 \times 75) =$

$$6.0 + 67.5 = 73.5$$

Mixed air temperature will be 73.5 degrees F when the OA is 60 degrees F and the RA is 75 degrees F with 10% outdoor air.

S25MFD180300 ASSEMBLY

- STEP - 1: SCREW THE MOTORIZED DAMPER ASSEMBLY TO THE BACK SIDE OF THE PANEL THRU THE ALIGNED HOLES AS SHOWN.
- STEP - 2: ADJUST DAMPER SLIDE TO PROPER REQUIRED AIR FLOW.
- STEP - 3: ATTACH ENTIRE PANEL ASSEMBLY TO RTU UNIT.

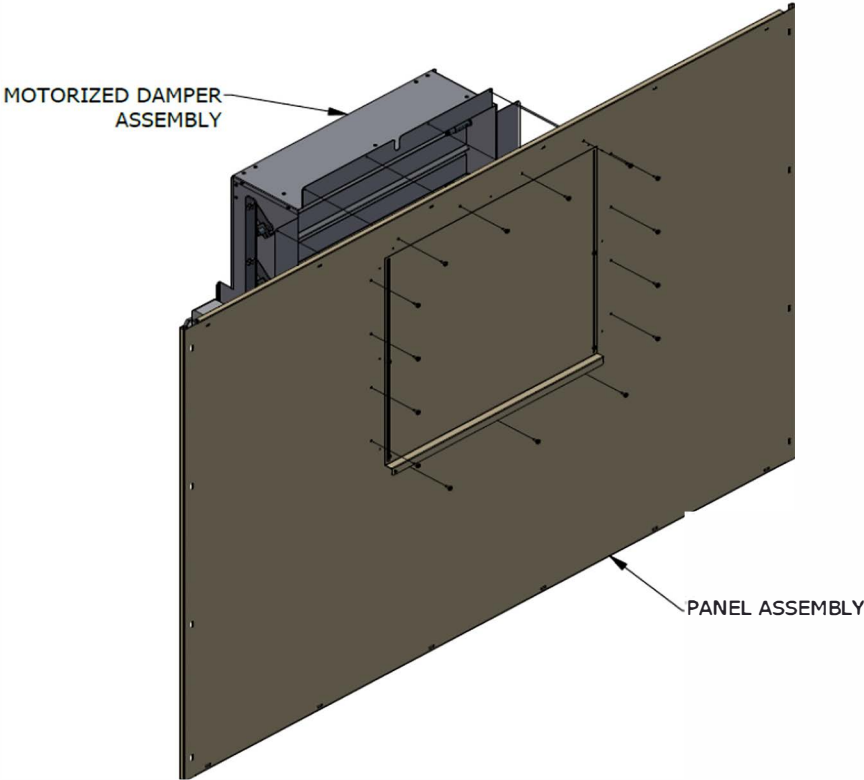

- STEP - 4: SCREW SIDE - 2 ASSEMBLY TO THE PANEL ASSEMBLY THRU ALIGNED HOLES AS SHOWN.

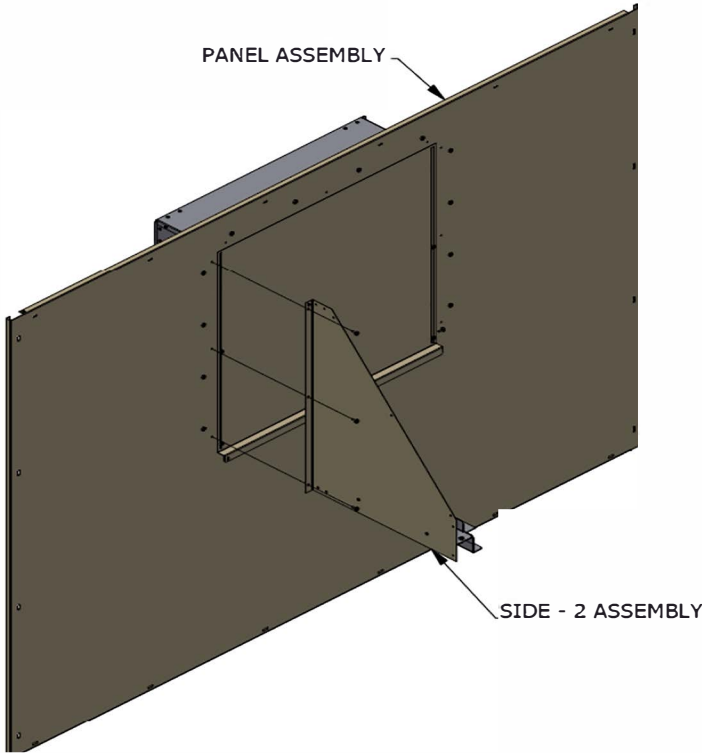

STEP - 5: SCREW THE BOTTOM ASSEMBLY TO SIDE - 2 & FILTER BLOCKOFF THRU ALLIGNED HOLES AS SHOWN.

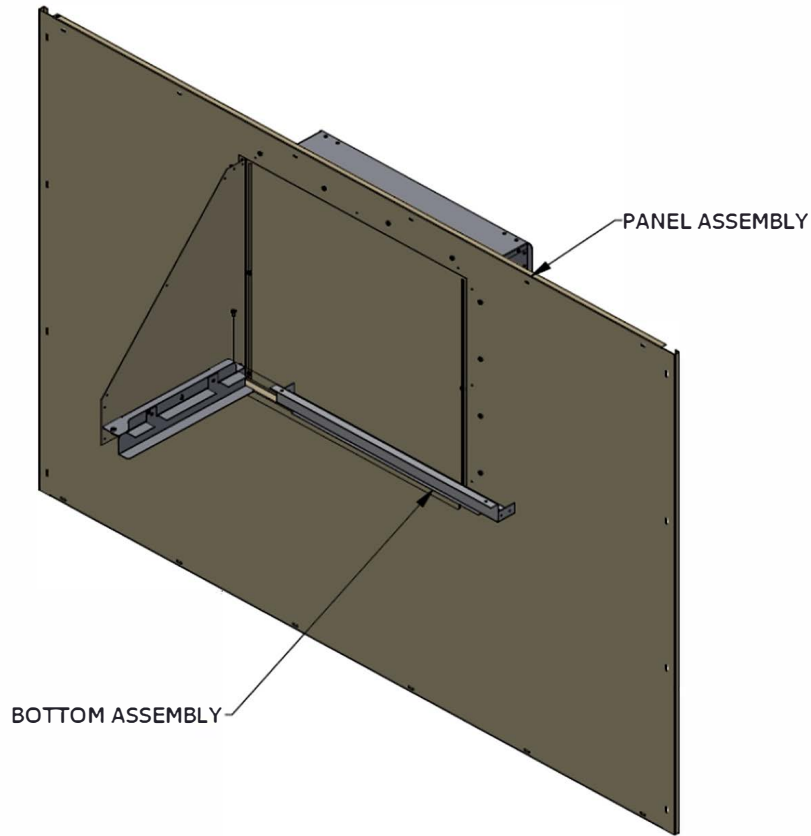

STEP - 6: SCREW SIDE - 1 ASSEMBLY TO THE PANEL & BOTTOM ASSEMBLY THRU THE ALIGNED SCREW HOLES AS SHOWN.

STEP - 7: SCREW FILTER STRAP TO THE FILTER BLOCKOFFS THRU ALIGNED SCREW HOLES AS SHOWN.

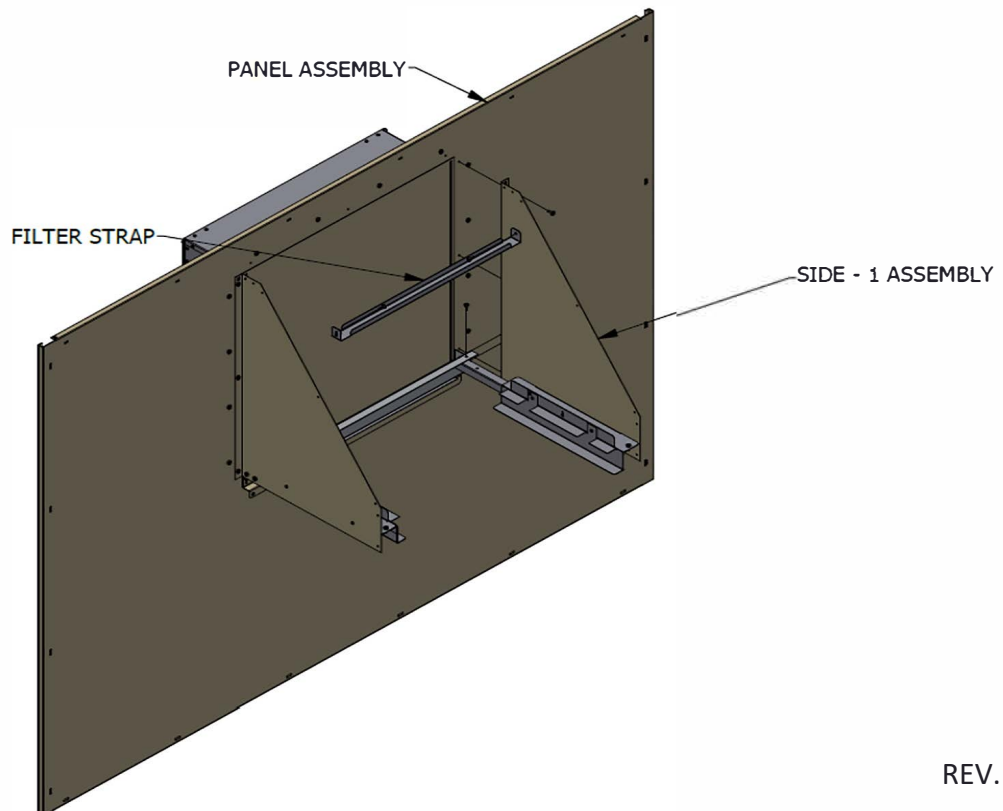

STEP - 8: SCREW HOOD HEEL TO HOOD SIDES 1 & 2 AND THE PANEL AS SHOWN.

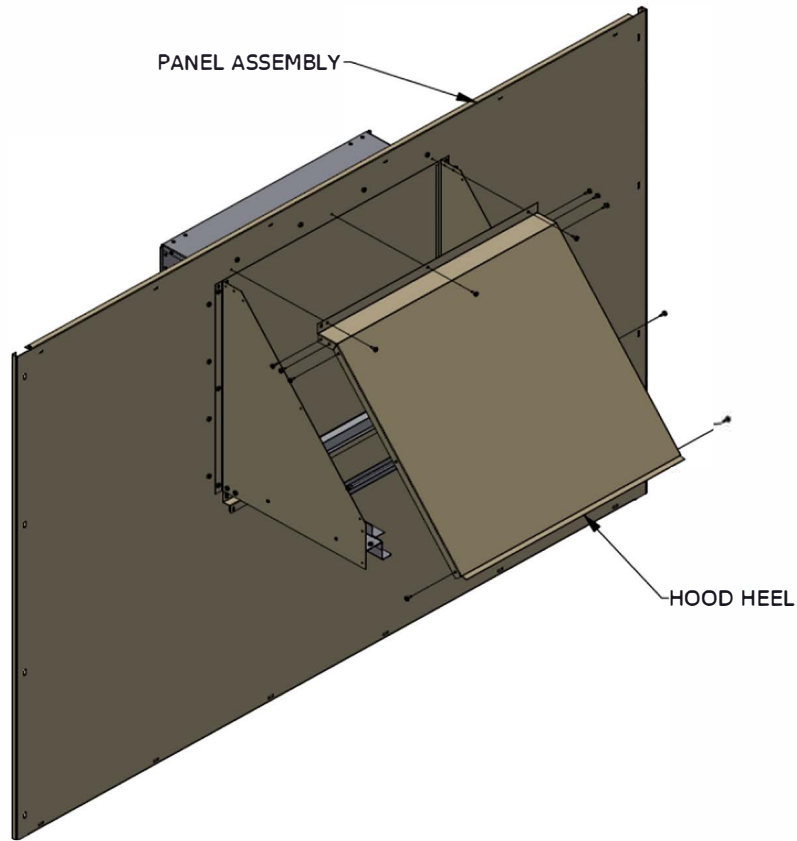

STEP - 9: INSERT 2 13 1/8" X 9 5/8" MIST ELIMINATORS INTO THE FILTER CHANNELS AS SHOWN.
STEP - 10: CUT DOWN HOG HAIR FILTER TO FIT IN THE SAME SPACE, THEN INSERT BETWEEN FILTER CHANNELS AS SHOWN.

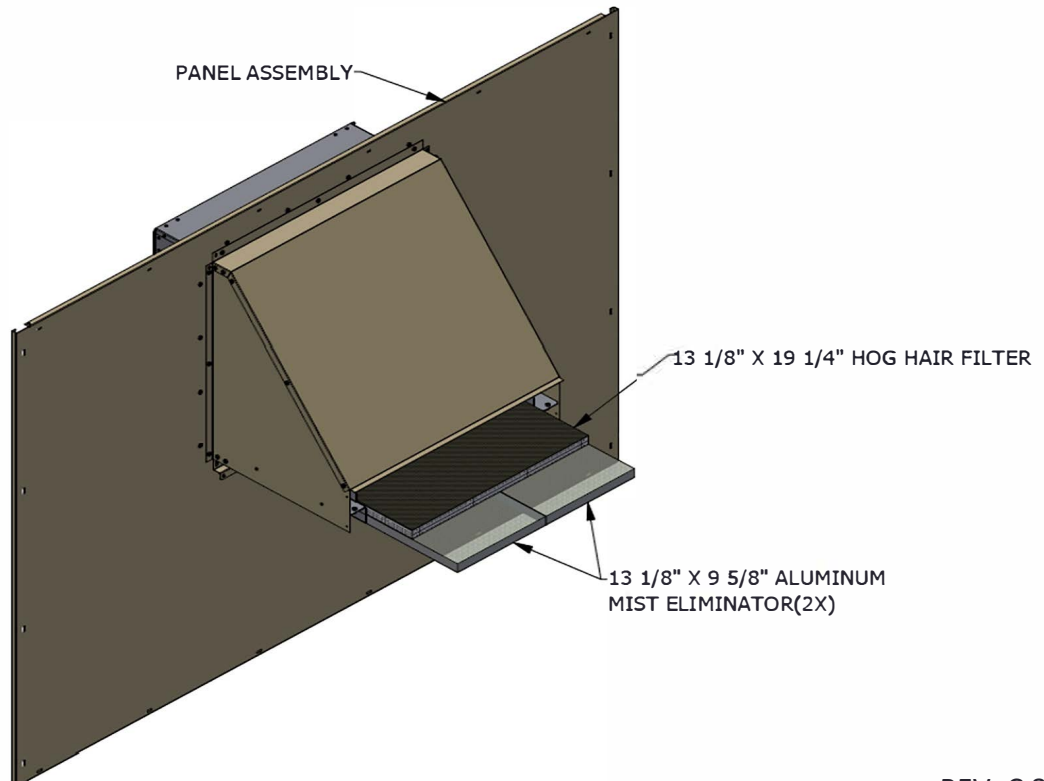

STEP - 11: SCREW THE FRONT TO THE HOOD SIDES AS SHOWN.

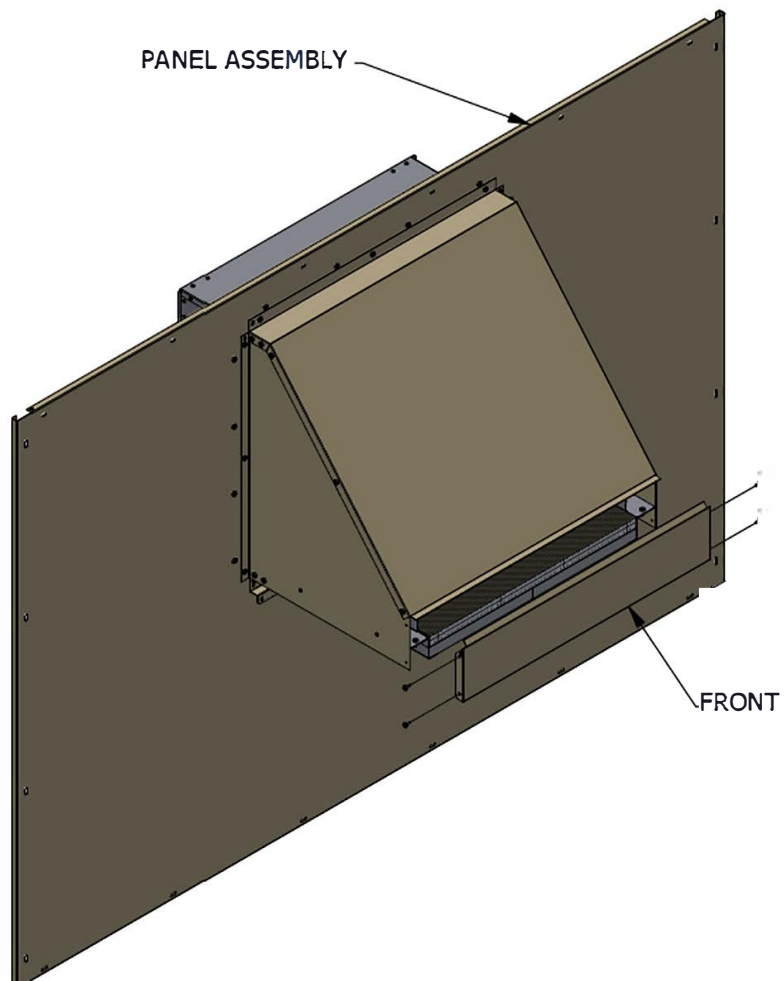

S25MFD180300 WIRE DIAGRAM REV 2

