

SEQUENCE OF OPERATION

This sequence assumes employment of a single enthalpy economizer using a two stage thermostat.

1. A call for cooling comes from room thermostat.
2. The enthalpy sensor determines if the atmospheric conditions are conducive for using outside air for cooling. If YES, the fresh air damper section of the economizer begins to open.
3. The EXH SET potentiometer should be set such that when the fresh air dampers are open approximately 70% of their full open capacity, EXH1 is energized and the power exhaust is powered to draw the relief air from the space. There is a 60 +/-30 second time delay built into the economizer control before the fan motor actually energizes.
4. When the dampers modulate below the 70% open position due to a satisfied thermostat or atmospheric conditions, the power exhaust disengages immediately.

INSTALLATION WITH ECONOMIZER

1. Open carton and inspect contents for shortages and damage.
2. Disconnect the power to the unit.
3. If the economizer is already fully installed, remove the economizer hood. If a new installation, do not install the economizer hood.
4. Slide the support legs through the guides, adjust as needed to level the cabinet, and fasten with supplied Tek screws, 2 places, per leg assembly (Figure 1).
5. Feed the line voltage and low voltage wires through the knockouts provided in the damper section of the economizer (Figure 2).
6. Attach the power exhaust hood. Extend the support legs and secure them using the screws provided.
7. Plug the power harness into the power exhaust connector located in the return cavity of the rooftop unit.
8. Attach the low voltage control leads to the Jade economizer controller per the included wiring diagram using the terminal blocks provided (Figure 3). **NOTE: For a DDC economizer installation, discard terminal blocks & control wires, and connect DDC economizer 24VAC control harness directly to PE relay coil.**
9. On the Jade control, set the position at which the exhaust will energize under the SETPOINTS menu.
10. Reinstall the filter access panel.

Figure 1

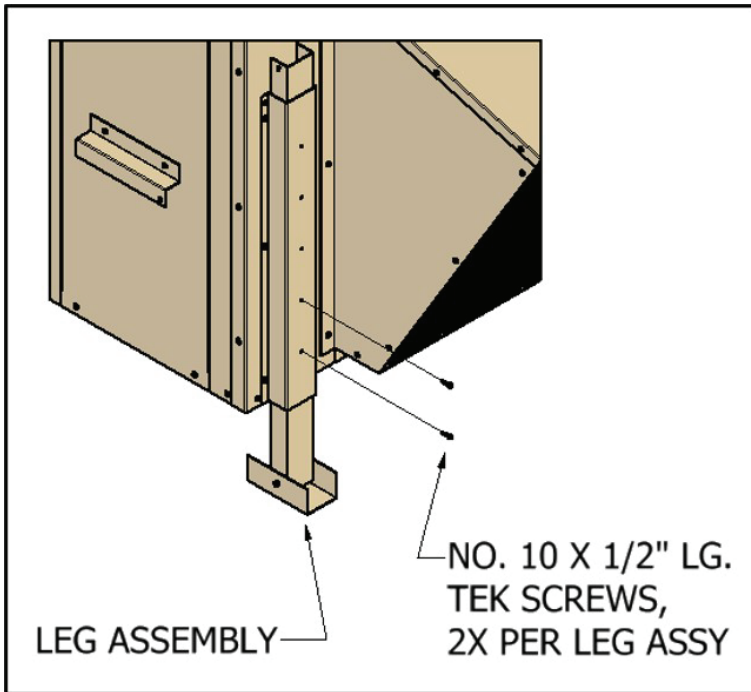
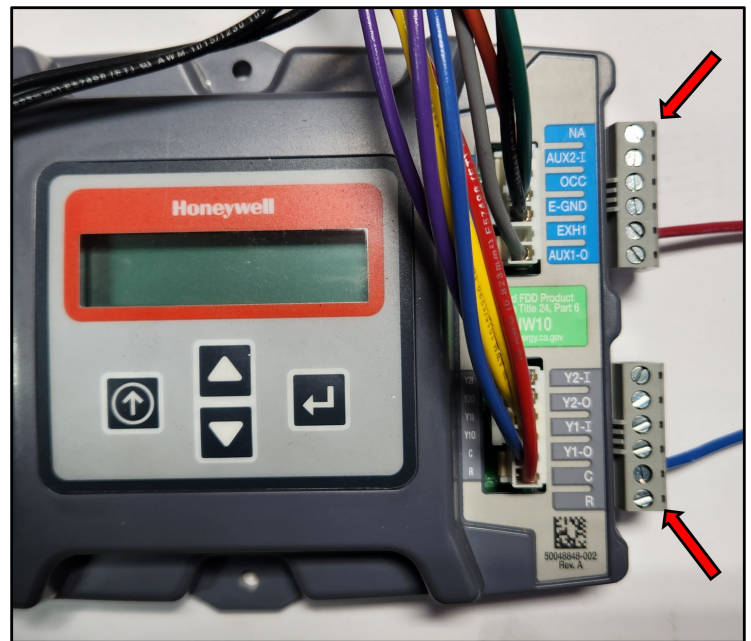

Figure 2



Figure 3



CONTENTS

QTY	DESCRIPTION
2	LEG ASSEMBLY
4	TEK SCREWS, #10 x 1/2" LG.
2	TERMINAL BLOCK, 6-PIN JADE CONNECTOR
1	INSTALLATION INSTRUCTION

Model	Voltage	Motor						
		HP	RPM	Type	FLA	MCA	FUSE SIZE	SPEEDS
SPE1803002	208/230-1-60	1/2 (X2)	1075	Direct Drive	4.8	6.0	10	1
SPE1803004	460-1-60	1/2 (X2)	1075	Direct Drive	2.4	3.0	5	1
SPE1803007	575-1-60	1/2 (X2)	1100	Direct Drive	2.2	2.8	5	1

SPE1803002 WIRE DIAGRAM

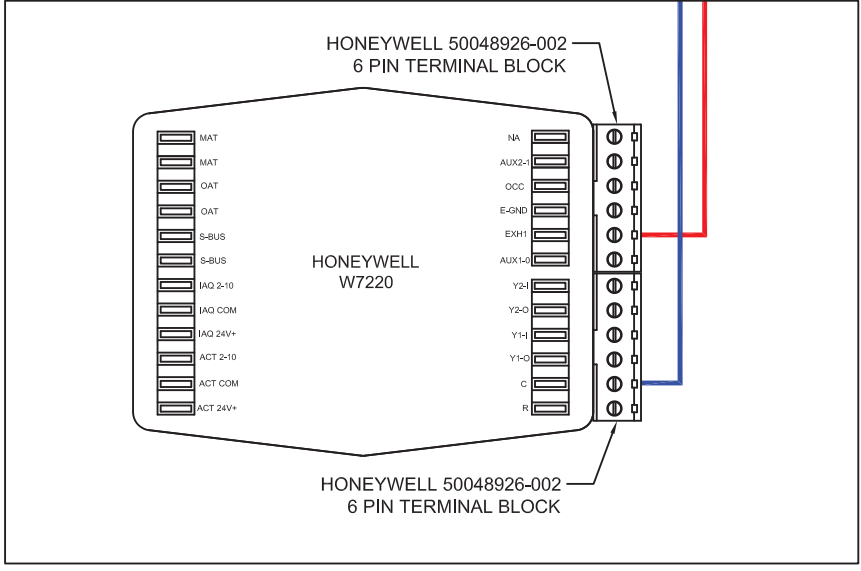
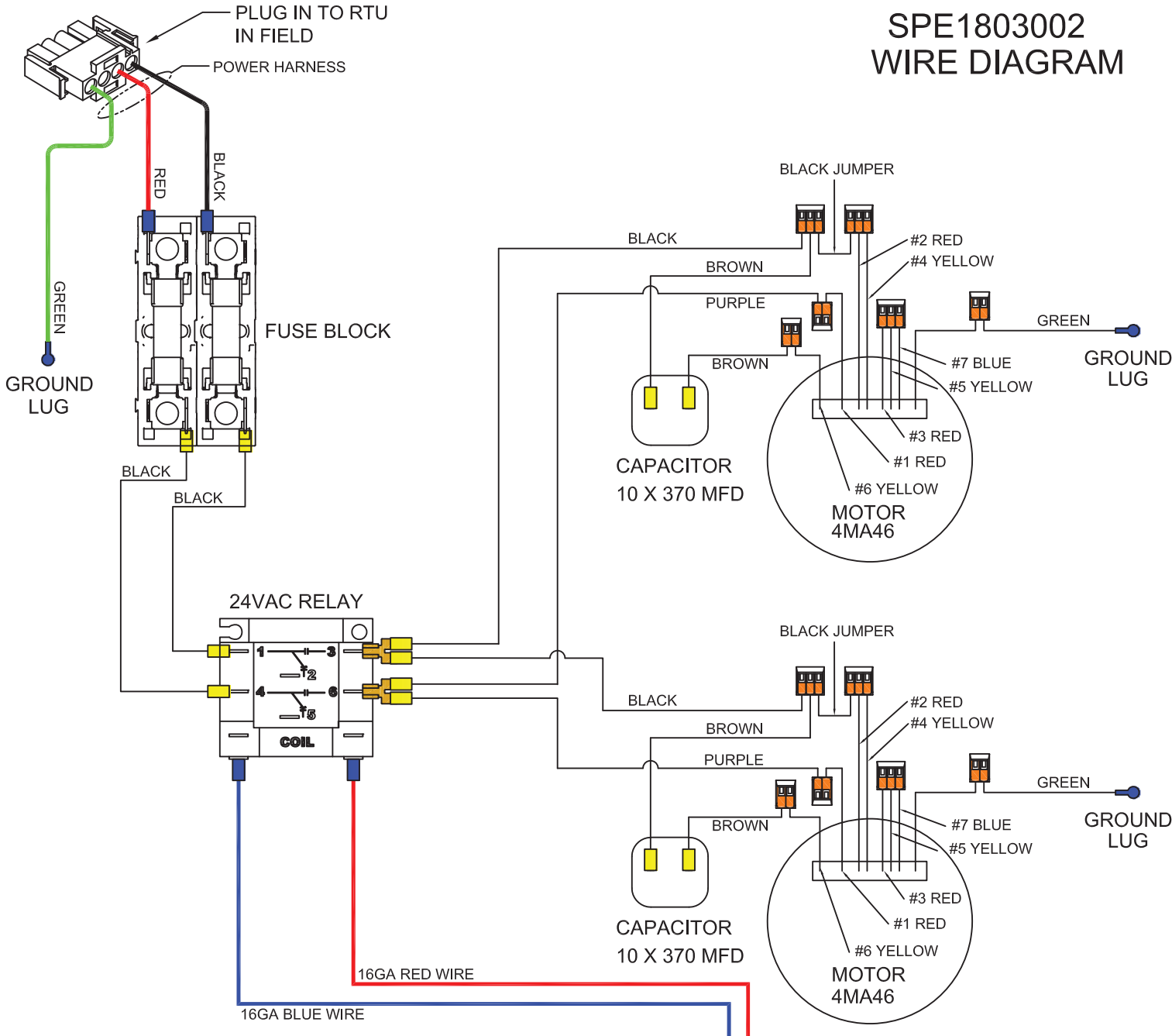

SPE1803004 WIRE DIAGRAM

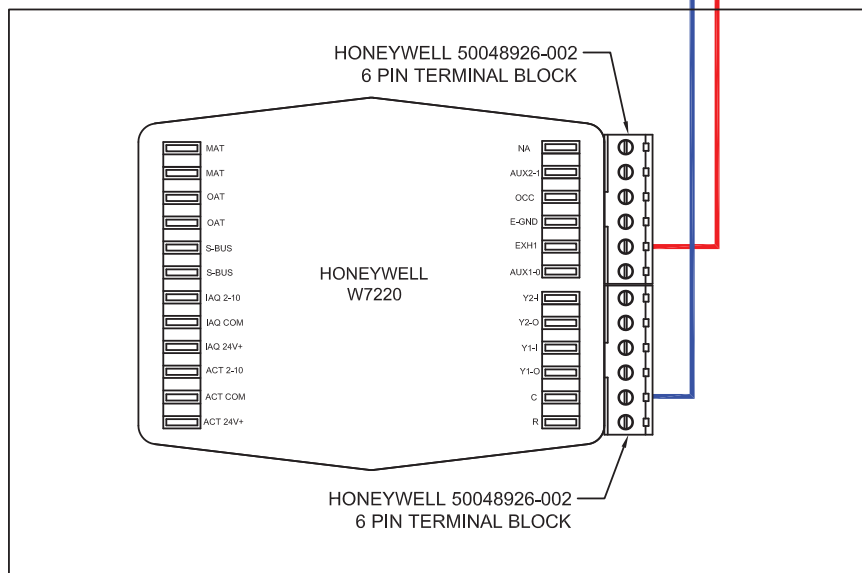
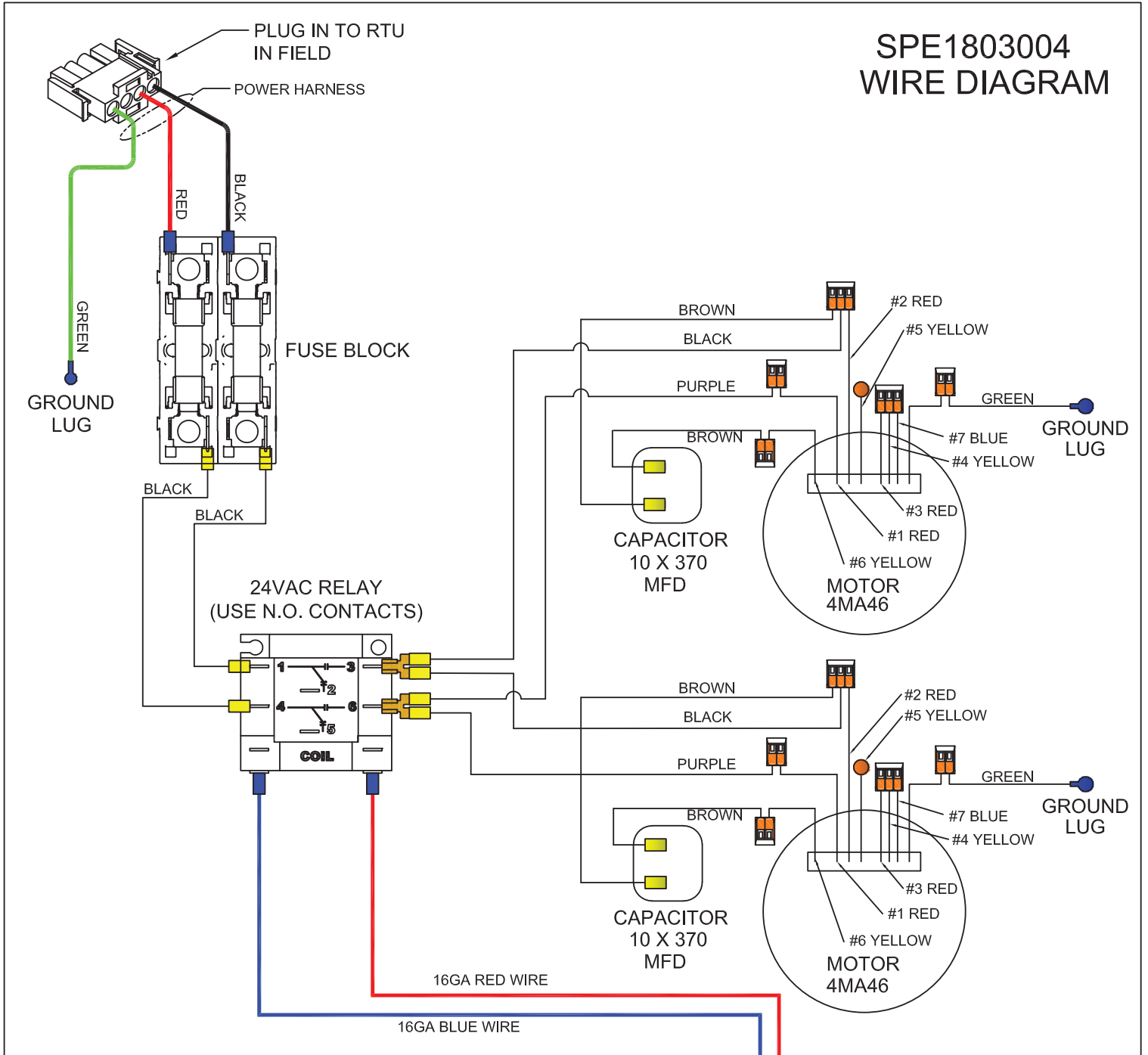

SPE1803007 WIRE DIAGRAM

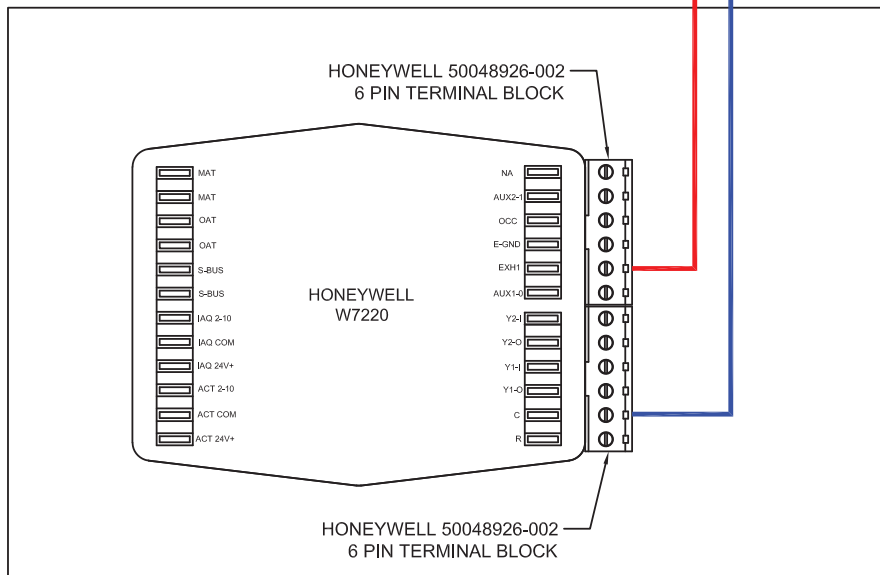
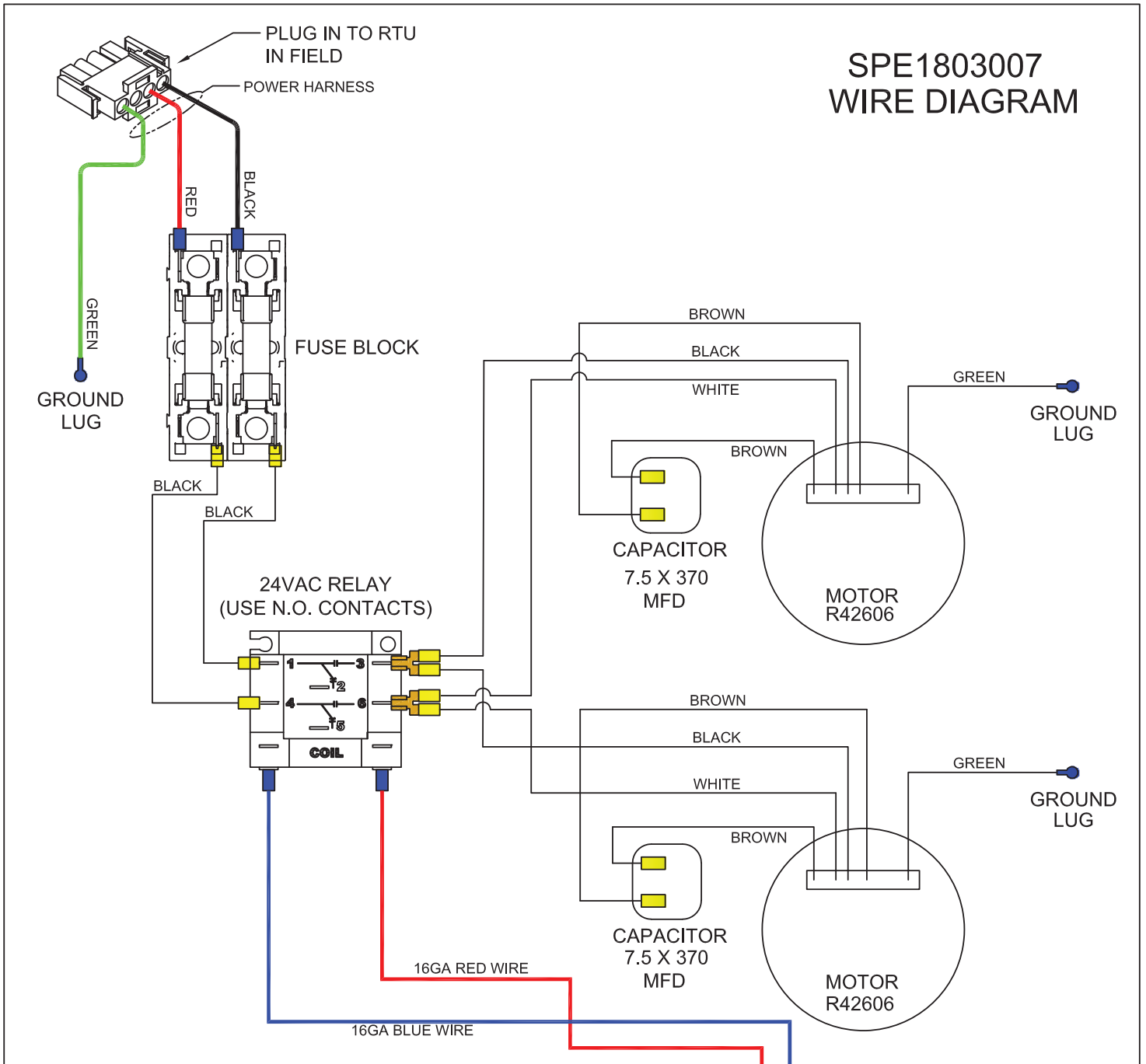

Lau Selection #1



MODEL F08Y202033

Selection Input	Input Flow 4000 CFM	Input Pressure 0.00 in-wg	Temperature 70 F	Altitude 0 ft	Q Derate 0 CFM	P Derate 0.00 in-wg	VAV Set Point 0.00 in-wg		Date 04-22-2015
Selection Output	Flow 3990 CFM	Pressure 0.00 in-wg	Power 0.28 hp	Static Efficiency 0.0 %	Total Efficiency 40.5 %	Speed 1100 rpm	Outlet Velocity 1741 fpm		
	Impeller Diameter 20.0 in	Outlet Area 2.29 ft²	Max Speed 1600 rpm	Pitch 33 deg	Drive Direct Drive	Blades 4	P Volume 0.7 ft³	Tumdown 100 %	

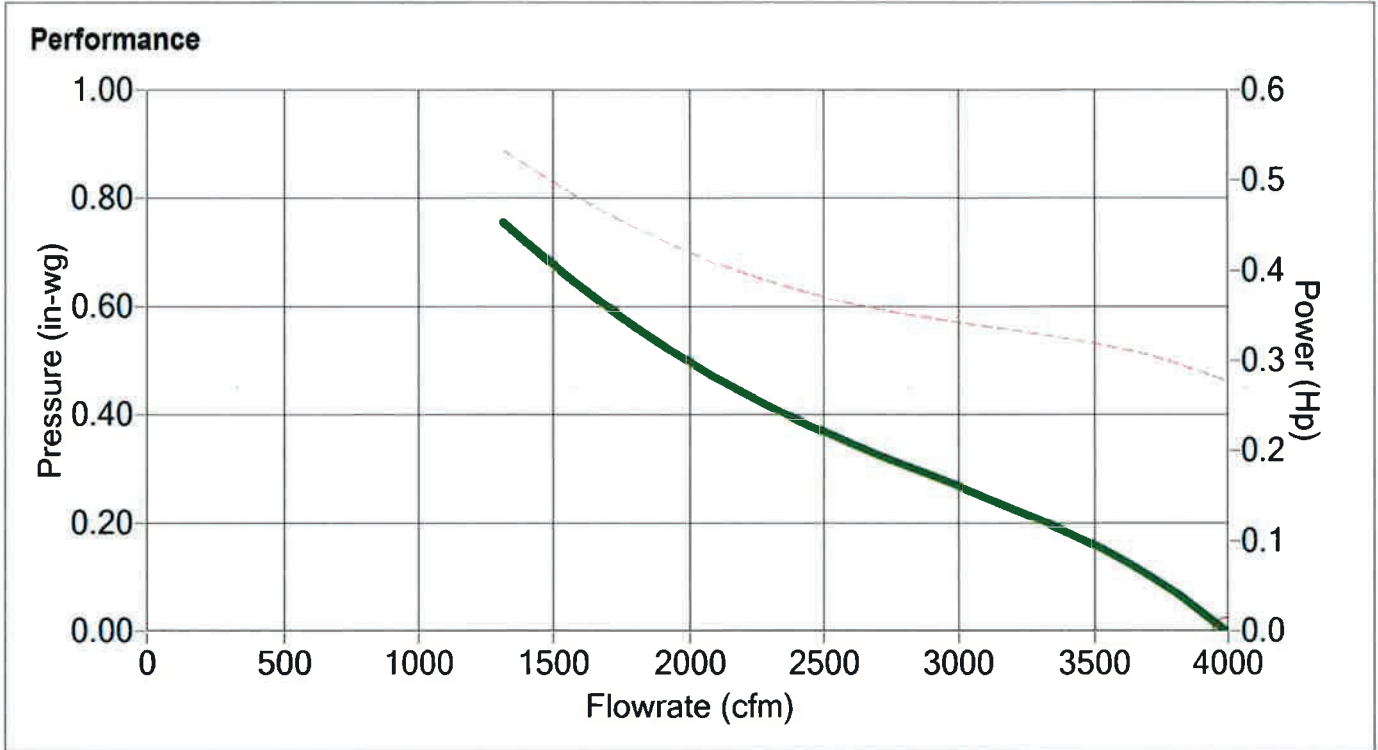

Sound	63	125	250	500	1000	2000	4000	8000	Lw	LwA
	N/A	N/A	N/A	N/A	N/A	N/A	N/A	N/A	N/A	N/A

Options

- Available Bore: 5/16, 3/8, 1/2 and 5/8 inch
- Keyway: Available in bore sizes 1/2 inch or larger
- Blade Material: Aluminum
- Spider Material: Painted Steel, Galvanized Steel
- Hub Location: Discharge side, Inlet side
- Set Screw Quantity: 1 or 2
- Rotation: Determine rotation by viewing discharge side of prop
Clockwise or counterclockwise

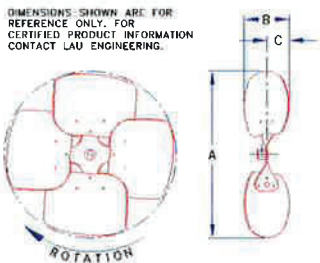

A	B	C
20.00	3.87	1.69

Dimensions in inches

Notes: Airflow performance data are obtained in accordance with AMCA 210-07. Installed performance will vary depending on extent of cabinet geometry