



**⚠ WARNING**

Only personnel that have been trained to install, adjust, service or repair (hereinafter, "service") the equipment specified in this manual should service the equipment. Daikin will not be responsible for any injury or property damage arising from improper service or service procedures. If you service this unit, you assume responsibility for any injury or property damage which may result. In addition, in jurisdictions that require one or more licenses to service the equipment specified in this manual, only licensed personnel should service the equipment. Improper installation, adjustment, servicing or repair of the equipment specified in this manual, or attempting to install, adjust, service or repair the equipment specified in this manual without proper training may result in product damage, property damage, personal injury or death.

**PROP 65 WARNING  
FOR CALIFORNIA CONSUMERS**

**⚠ WARNING**

Cancer and Reproductive Harm -  
[www.P65Warnings.ca.gov](http://www.P65Warnings.ca.gov)

0104M00517-A

**MODEL  
DQ-P-16-100**



\* Complete warranty details available from your local dealer/contractor or at [www.daikincomfort.com](http://www.daikincomfort.com).

## Description

The Daikin *One* Powered Ventilator is a cost-effective mechanical ventilation solution that helps manage the humidity and temperature in a home. Contractors and builders now have a practical offering for supplying constant outdoor air into the residence, meeting the ventilation requirements per ASHRAE guidelines.

## Proprietary Notice

This document and the information disclosed herein are proprietary data of Daikin North America LLC. Neither this document nor the information contained herein shall be reproduced, used, or disclosed to others without the written authorization of Daikin North America LLC, except to the extent required for installation or maintenance of recipient's equipment.

## Copyright Notice

Copyright 2020, Daikin North America LLC All rights reserved.

## Liability Notice

Daikin North America LLC does not accept any liability for installations of ventilation equipment installed by unqualified personnel or the use of parts/components/filters/equipment that are not authorized or approved by Daikin.

## Replacement Media Filters

Replacement Filter Part	
MERV 16	DQ-P-F-16
MERV 13	DQ-P-F-13

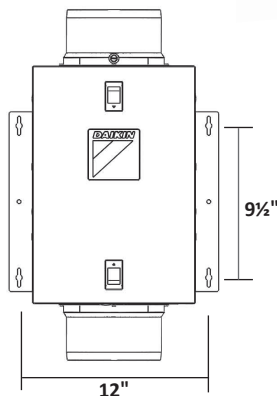
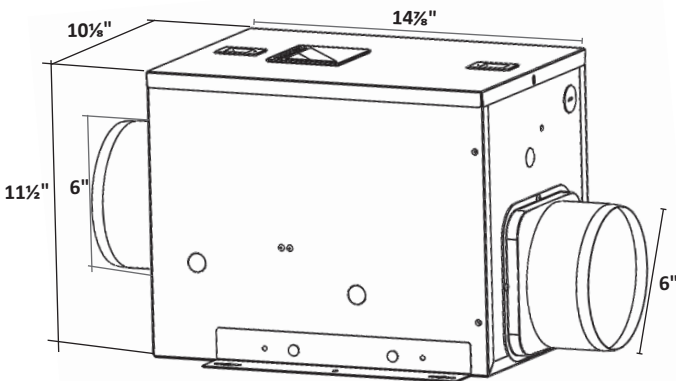

## Read and save these instructions

**WARNING!** This symbol indicates important instructions. Failure to heed them can result in serious injury or death.

**CAUTION!** This symbol indicates important instructions. Failure to heed them can result in injury or material property damage.

**WARNING!** Before beginning any installation or modification, be certain that the main line electrical disconnect switch is in the OFF position. Unexpected start-up of system blower may cause serious injury. Tag disconnect switch with suitable warning labels.

**WARNING!** This product can expose you to a chemical (or chemicals) known to the State of California to cause cancer.

**WARNING!** This product can expose you to a chemical (or chemicals) known to the State of California to cause reproductive toxicity.

## Installation

**CAUTION!** Only a heating/air conditioning installer or qualified service person should install your ventilator, unless you are completely familiar with the necessary tools, equipment and potential hazards involved. If you plan to install this ventilator yourself, please be aware that the improper use of any tool can be dangerous. Daikin will not assume any responsibility for failures due to incorrect installation procedures.

- Homeowners can perform the basic maintenance function of replacing filters.
- When working on the ventilator, observe precautions in this manual, labels attached to the furnace or air handler, and other safety precautions that may apply.
- Follow all safety codes. Wear safety glasses and work gloves.

**Table 1 - Power consumption of Ventilator at various flowrates**

Flow Rate @ 0.2" w.c.	
(CFM)	Power (W)
100	26.3
90	21.8
80	19.5
70	17.1
60	15.1
50	13
40	11.3

**Important: Read and save these instructions. This guide to be left with equipment owner.**

## Ventilator Accessories

The capabilities of the Daikin *One* Powered Ventilator can be enhanced by adding any of the following optional accessories (sold separately):

Heater (70 CFM & Higher)	DQ-P-70-AH-H
Motorized Damper kit	DQ-P-MDV
Air Intake Hood	DQ-P-AIH

## Installation

 **WARNING!** To reduce the risk of fire, electric shock and injury to person, observe the following:

1. Use this unit only in the manner intended by the manufacturer. If you have questions, contact Daikin.
2. Before servicing or cleaning the unit, switch power off at service panel and lock the service disconnecting means to prevent power from being switched on accidentally. When the service disconnecting means cannot be locked, securely fasten a prominent warning device, such as a tag, to the service panel.
3. Installation work and electrical wiring must be done by qualified person(s) in accordance with all applicable codes and standards, including fire-related construction.
4. When cutting or drilling into a wall or ceiling, do not damage electrical wiring or other hidden utilities.
5. To avoid motor bearing damage and noisy and/or unbalanced impellers, keep drywall spray, construction dust, etc. off power unit.
6. Read all instructions before installing or using ventilator.
7. For residential installations only.
8. Must use suitable air intake hood with insect screen to protect air intake.

 **WARNING!** For general ventilating use only. Do not use for exhausting hazardous or explosive materials and vapors.

 **WARNING!** Do not use this ventilator with any solid-state speed control device.

 **CAUTION!** Do not use in kitchens.

 **CAUTION!** The ducting from this ventilator to the outside of the building has a significant effect on the airflow, noise and energy consumption of the ventilator. Use the shortest, straightest duct routing possible between the ventilator and the home's exterior for best performance, and avoid installing the ventilator with smaller ducts than recommended. Insulation around the ducts can reduce energy loss and help inhibit mold growth. Ventilators installed with existing ducts may not achieve their rated airflow.

## General Installation Steps

 **CAUTION!** Make sure power is switched off at service panel before starting installation.

### Preparing the Ventilator

1. Unpack ventilator from the carton and confirm that all pieces are present. In addition to the ventilator you should have:
  - 2 - Collar Assemblies (attached at factory)
  - 2 - Mounting Brackets (attached at factory)
  - 1 - Controller (attached at factory)
  - 1 - Installation and Operation Manual
2. Choose the location for your ventilator. This ventilator will require at least 12" of clearance from the ceiling or wall to access the control compartment. It can be mounted using the mounting brackets provided or can be surface mounted to a wall or ceiling. To ensure the best air and sound performance, it is recommended that:
  - The length of ducting and the number of elbows should be kept to a minimum,
  - The radius of each elbow should be as large as possible for the installation, and
  - Insulated rigid duct should be used where possible.

**NOTE:** The ventilator must be installed in a location where it can be easily accessed for service once installed.

3. No additional vibration deadening materials are needed for this ventilator.

### Mounting the Ventilator

1. Confirm that the ventilator is positioned so the airflow is in the correct direction.
2. Mounting
  - a. Surface Mounting: Place the ventilator in a position so that at least one of the mounting brackets is centered on a stud or joist and mark the location for the four (4) holes in the mounting brackets for securing the ventilator. Remove the ventilator and install properly rated wall/ceiling anchors for any of the holes that do not go directly into a joist or stud. The ventilator weighs approximately 15 pounds not including the duct work attached to it. Position ventilator in place by securing with screws (not included) through the four (4) holes in the mounting brackets (Figure 1).
  - b. Mounting to a Joist: Install two, 2" x 4" headers (not included) between the joists to support the ventilator. Position the ventilator housing on the headers and secure the mounting brackets with screws (not included) to the headers (Figure 2).
  - c. Hanging Rods Mounting: Lift unit up onto the threaded rods and secure in place using appropriate hardware (not included). Threaded rods must each be a minimum of 24" in length (Figure 3). The installation shown in Figure 3 is upside down when installing to the threaded rod

Daikin North America LLC reserves the right to discontinue or change at any time, specifications or designs without notice or without incurring obligations. Performance of the Ventilator and/or Accessories will depend on house plan design, duct design and heating/cooling equipment.

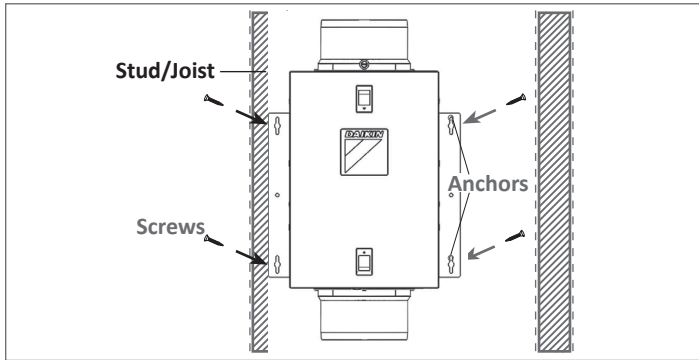

Figure 1 - Surface mounting of ventilator

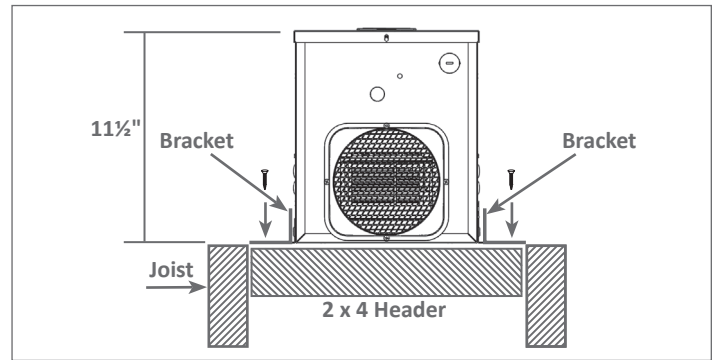

Figure 2 - Mounting ventilator to a joist

## Ducting the Ventilator

**NOTE:** 6" diameter or larger rigid duct is recommended for best performance.

**CAUTION!** All ducting must comply with local and national building codes.

**CAUTION!** The ducting from this ventilator to the outside of the building has a significant effect on the airflow, noise and energy consumption of the ventilator. Use the shortest, straightest duct routing possible between the ventilator and the home's exterior for best performance, and avoid installing the ventilator with smaller diameter ducts than recommended. Insulation around the ducts can reduce energy loss and help inhibit mold growth. Ventilators installed with existing ducts may not achieve their rated airflow.

**CAUTION** Make sure the outdoor air intake port complies with all local and national codes and is located at least 6 feet away from sources of contamination such as but not limited to: clothes dryer exhaust, furnace or central vacuum exhausts, gas appliances such as BBQ grills, garbage bins or other exhaust ports. **Note:** To ensure quiet operation of this ventilator, the ducting shall be installed using sound attenuation techniques appropriate for the installation. For bathroom and general ventilation applications, at least 8 feet of insulated flexible duct shall be installed between the exhaust or supply grille(s) and the ventilator.

1. Connect ducting to the ventilator's intake and outlet duct collars (Figure 4), sealing the joints with appropriately rated tape. Use screws or suitable clamps to secure in place. Make sure the outdoor air intake is connected to an intake port fitted with a suitable Air Intake Hood with insect screen to protect air intake. It is recommended that low restriction termination fittings be used.
2. To reduce the potential for condensation buildup within the duct, seal duct joints and exterior penetrations with mastic, caulk or other appropriate material to create an air-tight path to and from the ventilator.
3. To reduce the potential for building heat loss or gain and to reduce the potential for condensation, wrap insulation around duct and/or ventilator.

**NOTE:** At the base of the intake duct collar, there is a small test port hole covered with a red plastic cap. Make sure the test port is not covered up by the ducting or insulation and can be accessed for flowrate measurement. To access the port, remove the red, plastic port cover and insert pitot tube to measure flowrate.

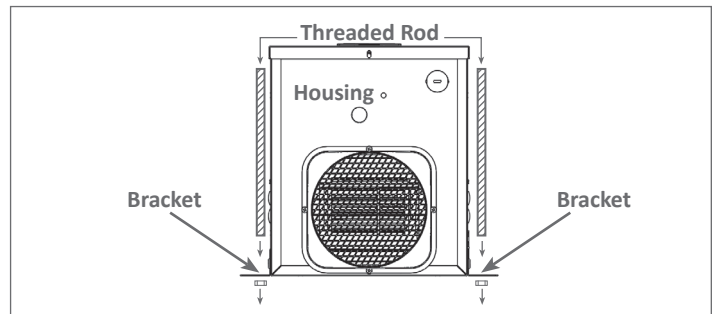

Figure 3 - Mounting ventilator using hanging rods

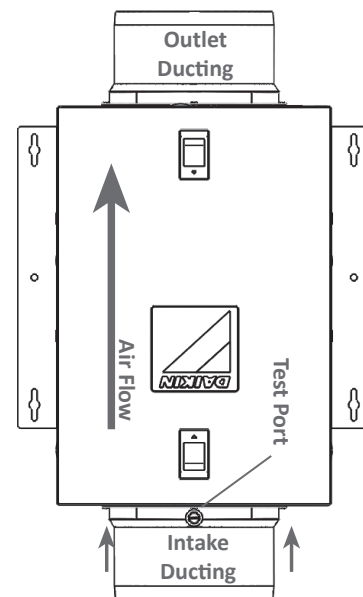

Figure 4 - Connecting ducting to the ventilator

**Wiring the Ventilator**

**CAUTION!**  
Make sure power is switched off at service panel before starting electrical work.

**CAUTION!**  
Installation work and electrical wiring must be done by qualified person(s) in accordance with all applicable codes and standards, including fire-related construction.

**Note:** This unit includes a small, wiring compartment for making electrical connections to the main power

1. Remove the wire compartment cover screw and set aside the screw and cover in a secure place (Figure 5).
2. Pull the loose black, white and green wires out from the wire compartment (additional wires will be present). Install an approved cable connector to the hole in the wire compartment cover (not included) to protect the wire from being cut by the sharp metal of the hole in the cover. Run a black (hot), white (neutral), and a green or bare ground wire from the supply through the cable connector. Connect all wires from the supply to their corresponding wires within the wire compartment (Figure 6). Use approved methods for all connections.
3. Carefully tuck wires back inside the wire compartment and replace wire compartment cover securing it with the screw that was removed earlier.

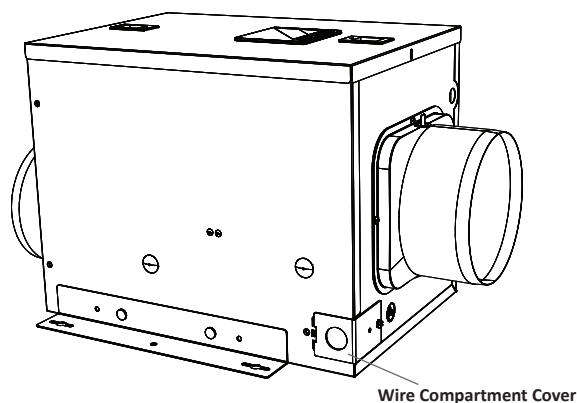

Figure 5 - Remove the wire compartment cover

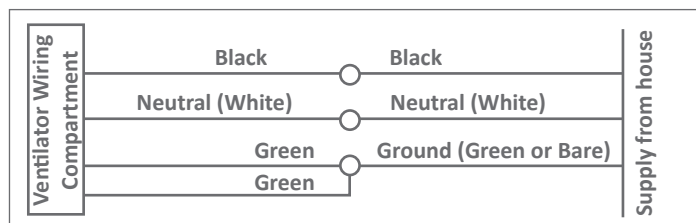

Figure 6

**Setting the Ventilation Flowrate**

1. Determine the CFM desired for ventilating the home. This unit can be set to deliver between 40 CFM and 100 CFM of outdoor air to the home in increments of 10 CFM.
2. Remove the screws securing the control compartment cover (a) and remove the cover (b) to gain access (Figure 7). Locate the speed control panel inside the unit.
3. Flowrate Selection
  - a. **For flowrate of 40 CFM to 70 CFM:** Push the toggle switch DOWN towards the “LOWER CFM” speed dial, then set the speed dial to the desired CFM (Figure 8).
  - b. **For settings of 80 CFM to 100 CFM:** Push the toggle switch UP towards the “HIGHER CFM” speed dial, then set the speed dial to the desired CFM (Figure 8).

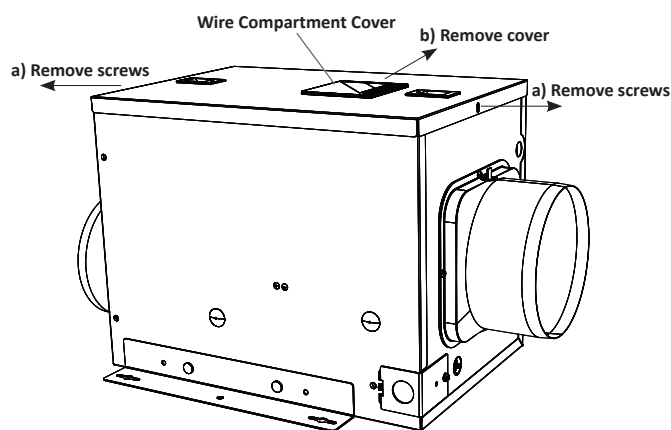

Figure 7 - Control Compartment Cover

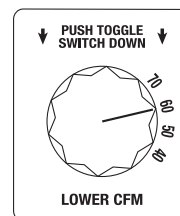
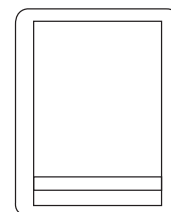
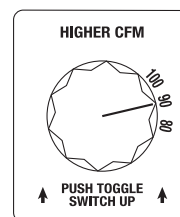

Figure 8 - Speed Control Panel

## Inline Media Air Filter

This ventilator includes a high efficiency MERV 16 inline media air filter which helps remove airborne particulates from the intake air. This filter has nominal dimensions of 10" x 10" x 2" with actual dimensions of 9.5" x 9.5" x 1-11/16".

**NOTE:** Inserting this filter in the airflow path decreases the airflow delivered by the unit. And flowrate is further decreased as the filter traps particles from the incoming air. As a result, the filter must be changed periodically to avoid excessive reduction in flowrate. In certain installations, the MERV 16 filter may be found to be too restrictive, reducing the airflow too much. In those cases, a replacement MERV 13 filter – part number DQ-P-F-13 should be considered.

### Installing or Changing the Air Filter:

1. Remove the two screws securing the control compartment cover and remove the cover to gain access to the controls and filter area (Figure 7).
2. Pull out the exhausted filter from the Control Compartment and place in the garbage.
3. Insert a new filter into the slot in the housing where the exhausted filter was installed. Make sure the filter is seated all the way to the bottom of the housing (Figure 9).
4. Close the control compartment cover and reinstall the screws holding it in place.

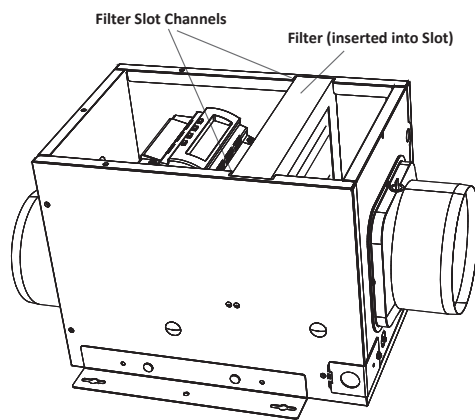

Figure 9 - Location of optional air filter

## Completing the Installation

**NOTE:** This unit is equipped with a wire mesh insect screen. Confirm that the screen is installed inside the control compartment just inside the intake port. Position the screen with its stamped depression towards the controller.

1. If, when the ventilator is unpacked, the insect screen is not in place, remove the Control Compartment cover (Figure 7) and insert the screen behind the tab at the base of the unit. Make sure the wider side of the screen is running side to side inside the unit (Figure 10).
2. Slide the screen to the side of the cabinet with the larger top tab making sure the screen fits behind the tab (Figure 10).

3. Then slide the screen in the opposite direction and tuck it behind the smaller tab (Figure 11).
4. Confirm that the screen is being held in place by both top tabs (Figure 11).
5. Reinstall the control compartment cover and the screws to hold it in place.
6. Restore power to the ventilator and test your installation.

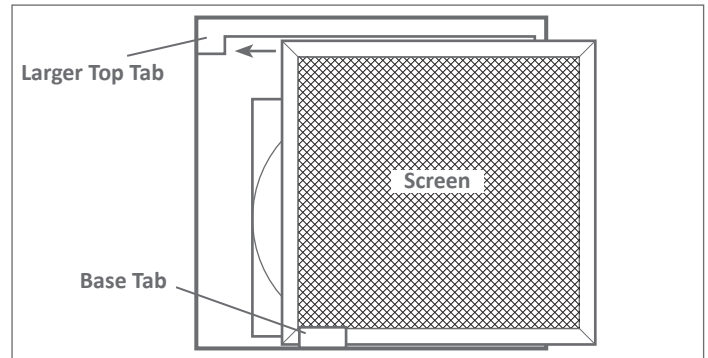

Figure 10 - Installing the insect screen

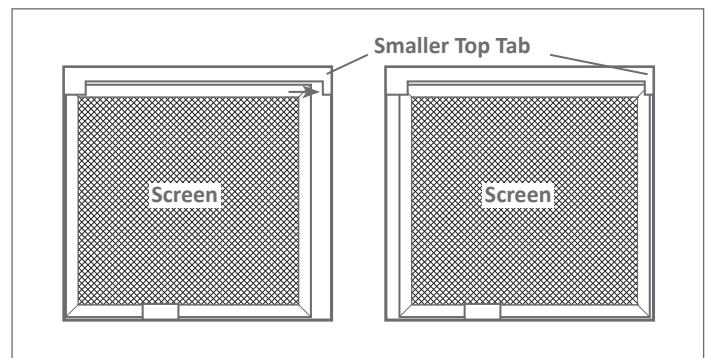

Figure 11 - Securing the insect screen in place

## Configuring the Controller

The controller mounted inside the ventilator monitors the temperature and humidity of the incoming air. The installer of this ventilator can configure this controller to suit the ventilation requirements of the home. Before configuring the controller, remove the protective plastic film from the controller's LCD screen.

With power to the ventilator turned on, the initial screen will show **OFF**. Press the **ON** button to show the current temperature and relative humidity. By pressing the **ON** button, the ventilator will initially turn on for continuous airflow of 30 CFM which is the factory default setting.

## Energy Saving Mode

**NOTE:** This ventilator is equipped with an Energy Saving Mode that allows upper and lower limits to be set for both temperature and humidity. Setting these limits will help prevent large swings in temperature or humidity caused by extreme conditions of the outdoor air entering the home. This will also help to reduce unnecessary energy consumption and improve occupant comfort.

1. Press the **ON/OFF/ENERGY SAVING** button to power on the ventilator. Press the **CONFIGURE** button once and the controller will display **F** and **Temp Unit** on the right hand side of the screen.
2. Press the **UP** or **DOWN** button to toggle the temperature display between Fahrenheit (F) or Celsius (C).
3. Press the **CONFIGURE** button again to set the Upper Limit Temperature. When air entering the home exceeds the Upper Limit Temperature value entered into the controller, the ventilator will stop running and will enter Sampling Mode. The words **Upper Limit** and **Temperature** will be displayed on the right hand side of the screen. Use the **UP** and **DOWN** buttons to adjust this temperature setting.
4. Press the **CONFIGURE** button again to set the Upper Limit Humidity level. When air entering the home exceeds the Upper Limit Humidity value entered into the controller, the ventilator will stop running and will enter Sampling Mode. The words **Upper Limit** and **Humidity** will be displayed on the right hand side of the screen. Use the **UP** and **DOWN** buttons to adjust this humidity setting.
5. Press the **CONFIGURE** button again to set the Lower Limit Temperature. When air entering the home falls below the Lower Limit Temperature value entered into the controller, the ventilator will stop running and will enter Sampling Mode. The words **Lower Limit** and **Temperature** will be displayed on the right hand side of the screen. Use the **UP** and **DOWN** buttons to adjust this temperature setting.
6. Press the **CONFIGURE** button again to set the Lower Limit Humidity. When air entering the home falls below the Lower Limit Humidity value entered into the controller, the ventilator will stop running and will enter Sampling Mode. The words **Lower Limit** and **Humidity** will be displayed on the right hand side of the screen. Use the **UP** and **DOWN** buttons to adjust this humidity setting. **NOTE:** Setting this value to **0** will override the set humidity level. This may be necessary in regions with very low ambient humidity.
7. Press the **CONFIGURE** button once more to return the display to the main screen. The word **ON** will be displayed in the top left corner of the screen. At this point, the configured settings have been stored.

### Using the Controller

#### 1. Energy Savings Mode

**NOTE:** To enter the Energy Savings mode, press the **ON/OFF/ENERGY SAVINGS** button until the words **Energy Savings** appear on the left side of the display. Energy Savings mode enables the settings that were selected in the Configuring the Controller section earlier in this manual.

#### Sampling Mode

When the ventilator is in Energy Savings Mode and either of the incoming air temperature or humidity is outside the limits programmed in the controller, the unit will enter "Sampling Mode". In Sampling Mode, the fan will shut down for 15 minutes followed by a 5-minute run period. The ventilator will continue this 15 minutes off/5 minutes on cycle until the intake air conditions are within the temperature and humidity limits programmed into the controller.

The controller will also enter Sampling Mode if the intake air drops below 33°F (1°C). It will cycle 5 minutes on / 15 minutes off until the temperature rises about 34°F (2°C).

2. **When the ventilator** is on, the screen will display the current temperature and relative humidity of the incoming outdoor intake air as well as the ventilator's operating mode (Energy Savings mode or not). Additional icons and information that may be displayed on the screen include:
  - Ventilator icon appears when the ventilator is on.
  - HI° F appears if the intake temperature is above 150° F (66° C)
  - Lo° F appears if the intake temperature is below 15° F (9° C)
  - Lo% appears if the intake humidity is below 10%.

#### Optional Heater Accessory Unit

An optional heater unit, model DQ-P-70-AH-H, is designed for climates where the outdoor air entering the ventilator can fall below 54°F (12°C). To install the heater unit, follow the instructions provided with that unit. Once installed and power is supplied to the heater unit, the ventilator controller LCD screen will now also display a thermometer icon. When the temperature of the intake air is between 39°F and 54° F (4 and 12° C), the heater unit will operate on Stage 1 heating and the number **1** will be displayed on the ventilator LCD screen; when the temperature is between 33° F and 39°F (1 and 4° C), the heater unit will operate on Stage 2 heating and the numbers **1 2** will be displayed on the screen.

#### Optional Motorized Damper

An optional Motorized Damper Kit, model DQ-P-MDV (sold separately) can be installed with the ventilator. When attached and wired to the ventilator, the Motorized Damper will open when the ventilator is operating and will close when the ventilator is turned off. For installation specifics, refer to the instructions included with the DQ-P-MDV Motorized Damper Kit.

#### Factory Reset

To restore the ventilator controller to factory default settings, make sure the unit is in the OFF setting. Push and hold both the UP and DOWN buttons for approximately 5 seconds until the word OFF on the display flashes once to confirm that the settings have been restored.

#### Maintenance

##### CAUTION!

Make sure power is switched off at the electrical service panel before servicing the unit.



1. Cleaning the Fan Assembly: Wipe all parts with a dry cloth or gently vacuum the fan. NEVER IMMERSE ELECTRICAL PARTS IN WATER.
2. Inline Air Filter: The air filter in this ventilator should be checked every month and replaced at least once every 3 months or more frequently if the airflow restriction becomes too great. To remove the spent filter, reverse the instructions outlined in the **Installing or Changing the Air Filter** section earlier in this manual.

**NOTE:** If you notice a large amount of insects and debris in the air filter, this could be a sign that the Air Intake Hood might be compromised and need repair or replacing.

#### Service Parts

- |                                   |                  |
|-----------------------------------|------------------|
| 1. Replacement MERV 16 Air Filter | Part # DQ-P-F-16 |
| 2. Replacement MERV 13 Air Filter | Part # DQ-P-F-13 |

**Troubleshooting Guide**

Trouble	Probable Cause	Suggested Remedy
1. Ventilator fan does not operate	1a. Control setting.	1a. Check temperature and humidity level settings. If the intake air is not within the preset range, the fan will not turn on. Either adjust the settings or wait for the intake air temperature and/or humidity to fall within programmed operating limits.
	1b. A fuse may be blown or a circuit tripped.	1b. Replace fuse or reset circuit breaker.
	1c. Wiring is not connected properly.	1c. Turn off power to unit. Check that all wires are connected.
	1d. Motor has stopped operating.	1d. Replace motor.
2. Fan is operating, but air moves slower than normal.	2a. Obstruction in the ducting.	2a. Check for any obstructions in the ducting. The most common are bird or insect nests in the Air Intake Hood.
	2b. Filter is clogged.	2b. Change air filter. 2b. Change/clear wire mesh insect screen.
3. Fan is operating louder than normal.	3a. Motor is loose.	3a. Turn off power to unit and check that all screws are fully tightened. Restore power to unit.
	3b. Fan blade is hitting housing of unit.	3b. Call your HVAC dealer for service.

**REPLACEMENT PARTS DIAGRAM**

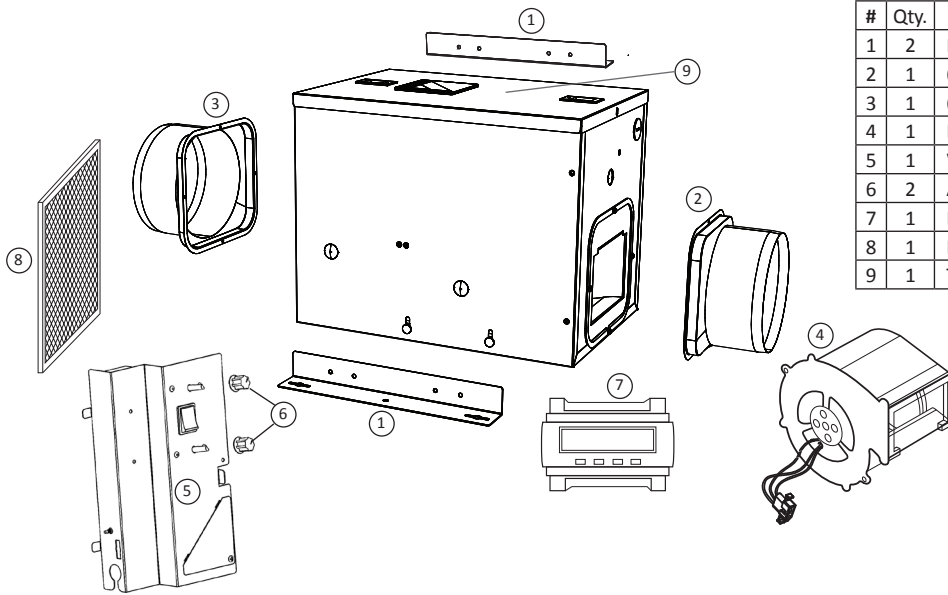

#	Qty.	Description	Replacement Part #
1	2	Mounting Bracket	DQ-P-MB
2	1	6" Metal Collar (Inlet)	DQ-P-MCI
3	1	6" Metal Collar (Outlet)	DQ-P-MCO
4	1	Blower Assembly	DQ-P-BA
5	1	Wire Compartment Assembly	DQ-P-WA
6	2	Adjustment Knobs	DQ-P-AK
7	1	LCD Controller	DQ-P-LCD
8	1	Insect Screen	DQ-P-SCREEN
9	1	Top Panel W/ Daikin Badge	DQ-P-TP-DB

Daikin North America LLC reserves the right to discontinue or change at any time, specifications or designs without notice or without incurring obligations. Performance of the Ventilator and/or Accessories will depend on house plan design, duct design and heating/cooling equipment.