

**McDANIEL METALS WITH SIEMENS  
CONTROLLER INSTRUCTIONS ECONOMIZER  
INSTALLATION 3-12.5 TON  
LIGHT COMMERCIAL ROOFTOP UNITS**

© 2026 Daikin Comfort Technologies Manufacturing, Inc.  
19001 KERMIER RD., WALLER, TX 77484  
[WWW.DAIKINCOMFORT.COM](http://WWW.DAIKINCOMFORT.COM)  
P/N: IOD-7169B DATE: APRIL 2026

**ATTENTION INSTALLING PERSONNEL**

As a professional installer you have an obligation to know the product better than the customer. This includes all safety precautions and related items.

Prior to actual installation, thoroughly familiarize yourself with this instruction manual. Pay special attention to all safety warnings. Often during installation or repair it is possible to place yourself in a position which is more hazardous than when the unit is in operation.

Remember, it is your responsibility to install the product safely and to know it well enough to be able to instruct a customer in its safe use. Safety is a matter of common sense...a matter of thinking before acting. Most dealers have a list of specific good safety practices... follow them.

The precautions listed in this installation manual are intended as supplemental to existing practices. However, if there is a direct conflict between existing practices and the content of this manual, the precautions listed here take precedence.

This product is designed and manufactured to permit installation in accordance with national codes. It is the installer's responsibility to install this unit in accordance with national codes and prevailing local codes and regulations.

**QUEBEC DISCLOSURE REGARDING AVAILABILITY OF REPLACEMENT PARTS, REPAIR SERVICES AND INFORMATION FOR MAINTENANCE AND REPAIR: DAIKIN COMFORT TECHNOLOGIES MANUFACTURING, INC. (DAIKIN) DOES NOT GUARANTEE THE AVAILABILITY OF (1) REPLACEMENT PARTS; (2) REPAIR SERVICES; AND (3) INFORMATION NECESSARY TO MAINTAIN OR REPAIR PRODUCTS, WITHIN THE MEANING OF SECTION 39.1 OF THE CONSUMER PROTECTION ACT, CQLR, c P-40.1 AND SECTION 79.18 OF THE REGULATION RESPECTING THE APPLICATION OF THE CONSUMER PROTECTION ACT, CQLR, c P-40.1, R. 3.**

**AVIS POUR LE QUÉBEC CONCERNANT LA DISPONIBILITÉ DES PIÈCES DE RECHANGE, DES SERVICES DE RÉPARATION ET DES RENSEIGNEMENTS POUR L'ENTRETIEN ET LA RÉPARATION : DAIKIN COMFORT TECHNOLOGIES MANUFACTURING, INC. (DAIKIN) NE GARANTIT PAS LA DISPONIBILITÉ (1) DES PIÈCES DE RECHANGE, (2) DES SERVICES DE RÉPARATION ET (3) DES RENSEIGNEMENTS POUR L'ENTRETIEN ET LA RÉPARATION, AU SENS DE L'ARTICLE 39.1 DE LA LOI SUR LA PROTECTION DU CONSOMMATEUR, RLRQ c P-40.1 ET DE L'ARTICLE 79.18 DU RÈGLEMENT D'APPLICATION DE LA LOI SUR LA PROTECTION DU CONSOMMATEUR, RLRQ c P-40.1, R 3.**



**WARNING**

ONLY PERSONNEL THAT HAVE BEEN TRAINED TO INSTALL, ADJUST, SERVICE, MAINTENANCE OR REPAIR (HEREINAFTER, "SERVICE") THE EQUIPMENT SPECIFIED IN THIS MANUAL SHOULD SERVICE THE EQUIPMENT.

THIS EQUIPMENT IS NOT INTENDED FOR USE BY PERSONS (INCLUDING CHILDREN) WITH REDUCED PHYSICAL, SENSORY OR MENTAL CAPABILITIES, OR LACK OF EXPERIENCE AND KNOWLEDGE, UNLESS THEY HAVE BEEN GIVEN SUPERVISION OR INSTRUCTION CONCERNING USE OF THE APPLIANCE BY A PERSON RESPONSIBLE FOR THEIR SAFETY.

CHILDREN SHOULD BE SUPERVISED TO ENSURE THAT THEY DO NOT PLAY WITH THE EQUIPMENT.

THE MANUFACTURER WILL NOT BE RESPONSIBLE FOR ANY INJURY OR PROPERTY DAMAGE ARISING FROM IMPROPER SUPERVISION, SERVICE OR SERVICE PROCEDURES. IF YOU SERVICE THIS UNIT, YOU ASSUME RESPONSIBILITY FOR ANY INJURY OR PROPERTY DAMAGE WHICH MAY RESULT. IN ADDITION, IN JURISDICTIONS THAT REQUIRE ONE OR MORE LICENSES TO SERVICE THE EQUIPMENT SPECIFIED IN THIS MANUAL, ONLY LICENSED PERSONNEL SHOULD SERVICE THE EQUIPMENT. IMPROPER SUPERVISION, INSTALLATION, ADJUSTMENT, SERVICING, MAINTENANCE OR REPAIR OF THE EQUIPMENT SPECIFIED IN THIS MANUAL, OR ATTEMPTING TO INSTALL, ADJUST, SERVICE OR REPAIR THE EQUIPMENT SPECIFIED IN THIS MANUAL WITHOUT PROPER SUPERVISION OR TRAINING MAY RESULT IN PRODUCT DAMAGE, PROPERTY DAMAGE, PERSONAL INJURY OR DEATH.



**WARNING**

Do NOT BYPASS SAFETY DEVICES.



**WARNING**

High VOLTAGE!  
DISCONNECT ALL POWER BEFORE SERVICING OR INSTALLING THIS UNIT. LOCKOUT-TAGOUT PROCEDURE SHOULD BE FOLLOWED. MULTIPLE POWER SOURCES MAY BE PRESENT. FAILURE TO DO SO MAY CAUSE PROPERTY DAMAGE, PERSONAL INJURY OR DEATH.



## GENERAL INFORMATION

This installation and operating manual covers field installed downflow economizers for Daikin commercial package models. These economizers are available with dry bulb or enthalpy sensors and are offered on 3 - 12.5 ton models. Economizers can be ordered for low leak or ultra low leak applications. Except for DDC models, this economizer kit must be used with a two stage thermostat.

## SAFETY CONSIDERATIONS

Installation and servicing of air conditioning equipment can be hazardous due to system pressure and electrical components. Only trained and qualified service personnel should install, repair, or service air conditioning equipment.

All operations should be performed by trained service personnel. When working on air conditioning equipment, observe precautions in the literature, tags and labels attached to the unit or accessory, and other safety precautions that may apply.

Follow all safety codes. Wear safety glasses and work gloves.

## ECONOMIZER GENERAL INFORMATION

Economizers are used to let free-cooling into the building when the outdoor air is cool enough and therefore reducing the need to turn on your compressors for mechanical cooling. This is accomplished by the controller sending a command to the economizer to open the damper when the outside air is suitable to be used for free cooling. This offers an energy savings to the building owner. In the event that free-cooling alone cannot satisfy the cooling demand in the space, the controller will activate the 1st stage of mechanical cooling and both free-cooling and mechanical cooling will be used together.

If the outside air dampers are open and the air becomes too warm (or humid with enthalpy control) the dampers will be commanded to modulate to the minimum position (ventilation) set point. When doing so the compressors will provide mechanical cooling to the building. When the unit is in heating mode the economizer will be at minimum position.

Economizers are also able to open to a minimum position and offer fresh air (ventilation air) into the building to meet code requirements. The controller has the ability to set 2 separate minimum position settings for 2 speed units.

Economizers are provided with dampers, an actuator to control the damper movement, an outside air sensor (if required), a mixed air sensor (if required), a factory mounted controller (if required), all necessary economizer wiring, barometric relief dampers, and an economizer hood.

Part #	Sensor	Tonnage
0270L02962MC	Dry Bulb	3-6
0270L02963MC	Enthalpy	3-6
0270L02959MC	Dry Bulb	7.5-12.5
0270L02960MC	Enthalpy	7.5-12.5
0270L02964MC	DDC	3-6
0270L02961MC	DDC	7.5-12.5

TABLE 1 - DOWNFLOW ECONOMIZER KIT PART NUMBERS

Part #	Sensor	Tonnage
0270L03028MC	Dry Bulb	3-6
0270L03029MC	Enthalpy	3-6
0270L03031MC	Dry Bulb	7.5-12.5
0270L03032MC	Enthalpy	7.5-12.5
0270L03030MC	DDC	3-6
0270L03033MC	DDC	7.5-12.5

TABLE 2 - HORIZONTAL ECONOMIZER KIT PART NUMBERS

## LOCATION

The location for installation of downflow economizers is to be in the return air section. This installation will be common for all Commercial Rooftop Units.

## DOWNFLOW ECONOMIZER INSTALLATION

1. Open carton and inspect contents for damaged or missing parts. Service Tech. Line: 281-987-8400 ext. 116
2. Take Filter Access Panel off of unit. Keep for installation back on to unit when economizer installation is complete. See Figure 1.

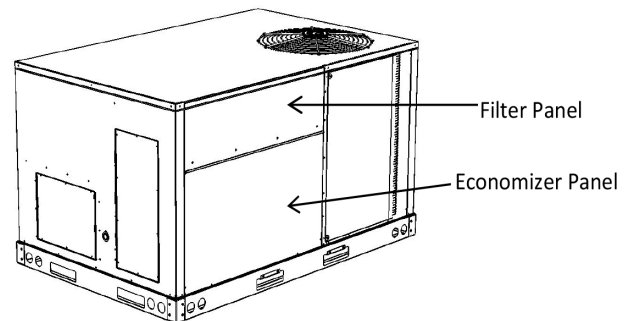
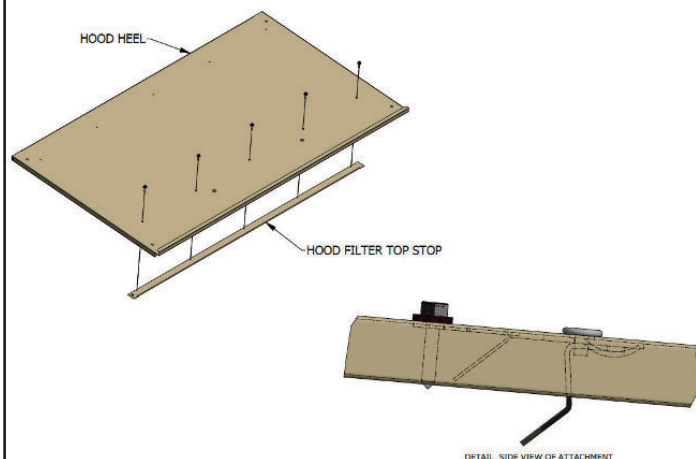


FIGURE 1 - REMOVE PANELS

3. Remove lower panel from return air section of unit. See Figure 1. This panel can be discarded. Keep removed screws for use in later step.
4. Place economizer in return air section of the unit over the downflow duct opening.
5. Install the economizer using the screws removed from the lower panel in Step 3.

STEP - 1: USE PROVIDED SCREWS THAT HAVE NEOPRENE WASHERS TO ATTACH THE HOOD FILTER TOP STOP TO THE HOOD HEEL.



**FIGURE 2 - ECONOMIZER HOOD ASSEMBLY**

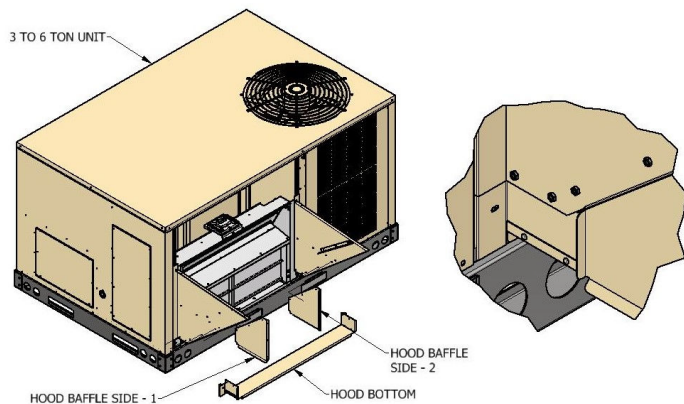
6. Assemble the hood per the exploded view in Figure 2 using the screws provided.

7. Follow the steps in Figures 3 to 9 in order.

STEP - 1: USE THE REMAINING 2 SCREWS/WASHERS FROM THE PANEL TO ATTACH THE HOOD BOTTOM TO THE UNIT.

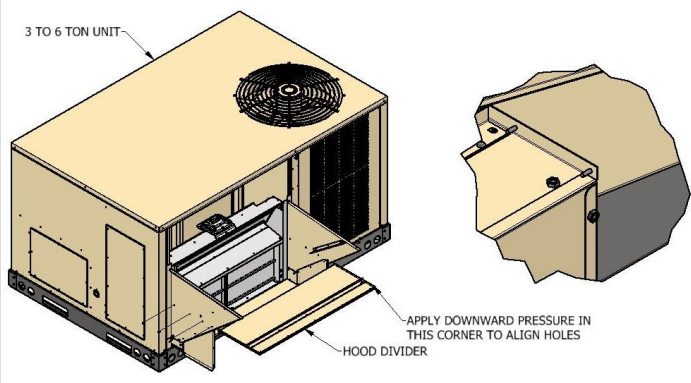
STEP - 2: USE THE 5/16" HEAD SCREWS PROVIDED TO ATTACH THE HOOD BOTTOM TO THE HOOD SIDES THRU THE ALIGNED GUIDE HOLES.

STEP - 3: USE THE 5/16" HEAD SCREWS PROVIDED TO ATTACH THE BAFFLE SIDES TO SIDES 1 & 2, THESE SHOULD OVERLAP THE BOTTOM.



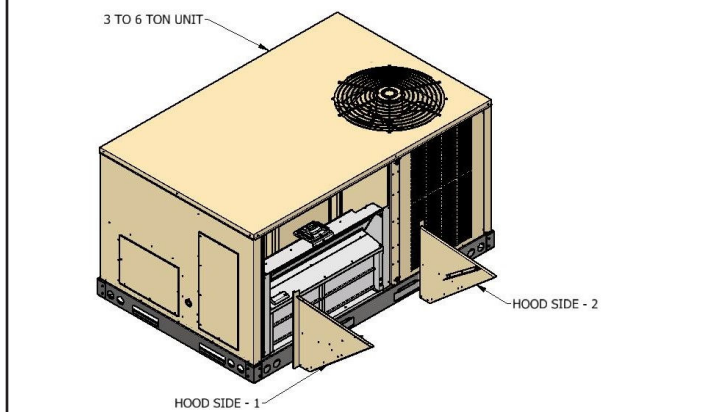
**FIGURE 4**

STEP - 1: USE 5/16" HEAD SCREWS PROVIDED TO ATTACH THE HOOD DIVIDER TO THE HOOD SIDES.



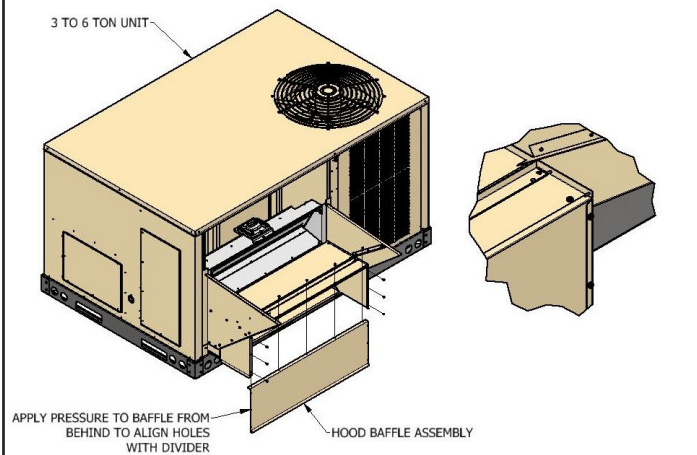
**FIGURE 5**

STEP - 1: REMOVE THE BUBBLE WRAP FROM EACH OF THE HOOD PARTS.  
 STEP - 2: SCREW BAFFLE SIDES 1 & 2 TO HOOD SIDES AS SHOWN.  
 STEP - 3: USE ONE OF THE SCREWS /W WASHERS RETAINED FROM THE PANEL IN STEP 2, TO ATTACH HOOD SIDE - 1 TO THE UNIT THRU THE ECONOMIZER.  
 STEP - 4: USE ONE OF THE SCREWS /W WASHERS RETAINED FROM THE PANEL IN STEP 2, TO ATTACH HOOD SIDE - 2 TO THE UNIT THRU THE ECONOMIZER.



**FIGURE 3**

STEP - 1: USE PROVIDED 5/16" HEAD SCREWS TO ATTACH THE HOOD BAFFLE FRONT TO THE BAFFLE SIDES & DIVIDER.



**FIGURE 6**

STEP - 1: SLIDE PROVIDED MIST ELIMINATOR INTO PLACE UP AGAINST THE FILTER ANGLES.

STEP - 2: USE PROVIDED  $\frac{5}{16}$ " HEAD SCREWS TO ATTACH THE HOOD HEEL TO THE HOOD SIDES.

STEP - 3: FLIP DOWN THE LATCHES ON THE UNDERSIDE OF THE HOOD HEEL TO HOLD THE MIST ELIMINATOR INTO PLACE.

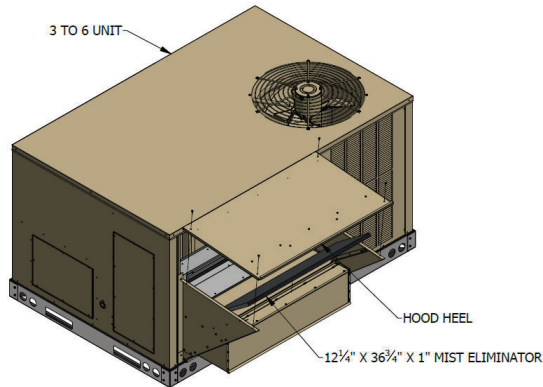


FIGURE 7

STEP - 1: USE THE PROVIDED SCREWS WITH NEOPRENE WASHERS TO ATTACH THE HOOD RAIN GUARD TO THE HOOD HEEL.

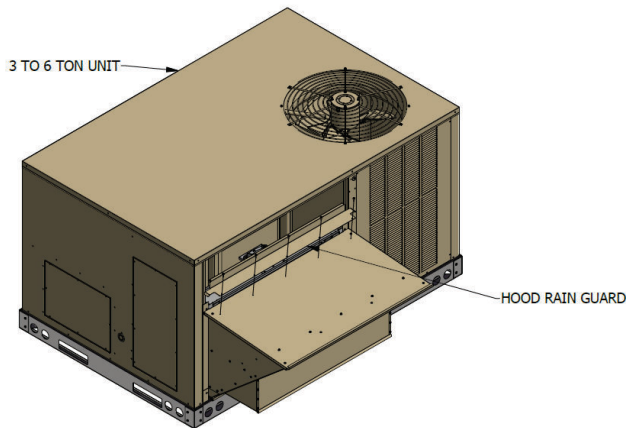


FIGURE 8

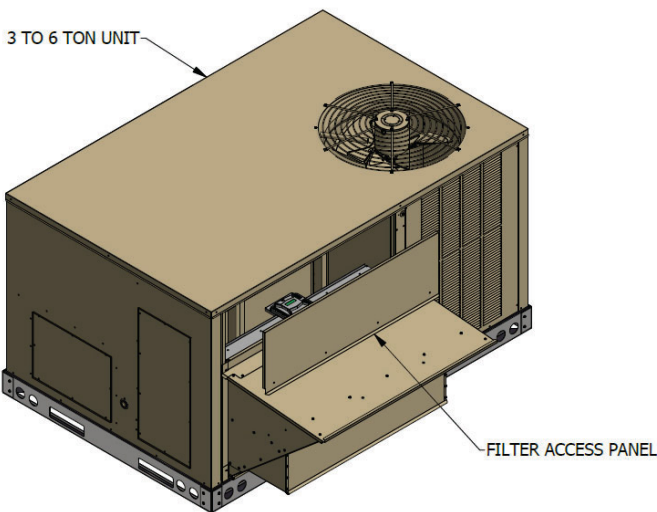


FIGURE 9

## HORIZONTAL ECONOMIZER INSTALLATION

Models have additional components mounted onto the horizontal return air panel and in the return air duct.

**TO INSTALL THE 3 - 6 TON HORIZONTAL ECONOMIZER, PERFORM THE FOLLOWING PROCEDURE:**

The location for installation of horizontal economizers is in the return air section.

1. Open carton and inspect contents for damaged or missing parts.
2. Take Filter Access Panel off of unit. This panel can be discarded. (see Figure 10).

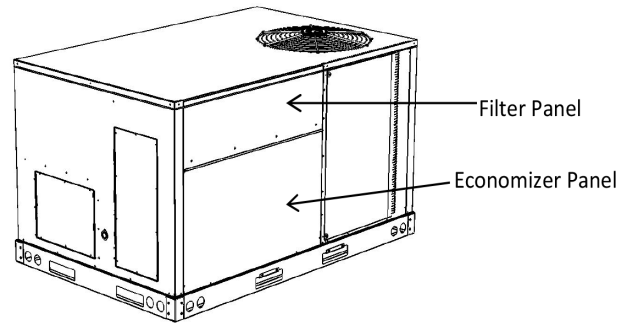
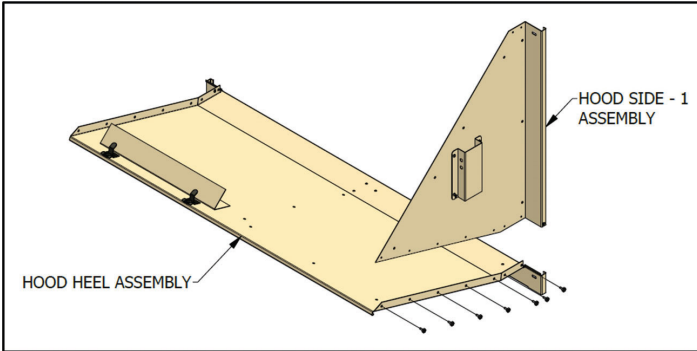


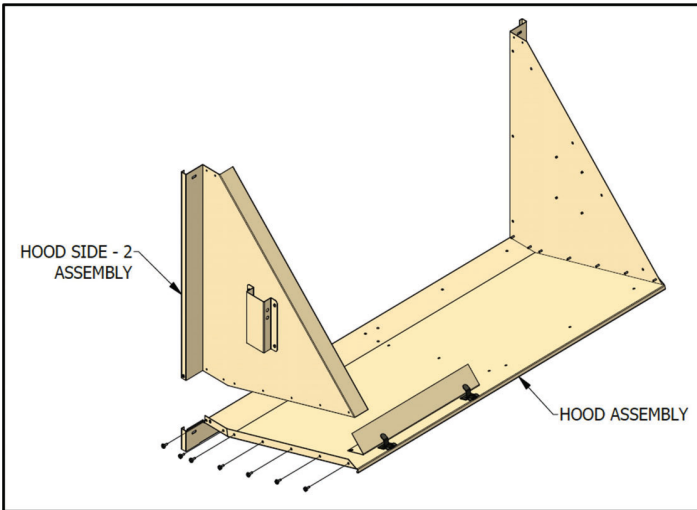
FIGURE 10 - REMOVE PANELS

3. Remove economizer panel from return air section of unit (see Figure 10). This panel can be discarded. Keep removed screws for use in later step.
4. Remove the horizontal return air opening cover and secure it over the downflow return opening per unit installation instructions. (See horizontal duct clips).
5. Place economizer in return air section of unit aligned with the horizontal duct opening (see Figure 18).
6. Use provided sheet metal screws to assemble the economizer hood. Per Figure 11, attach Hood Side - 1 to the Hood Heel using 7 screws.
7. Per Figure 12, attach Hood Side - 2 to the Hood Heel using 7 screws.
8. Per Figure 13, attach Hood Divider to the Hood Assembly using 7 screws.
9. Per Figure 14, attach the Barometric Relief Assembly to the Hood Assembly using 9 screws.
10. Per Figure 15, attach the Bird Screen to the Hood Assembly using 11 screws.
11. Per Figure 16, attach Hood Bottom Assembly to Hood Assembly using 10 screws.
12. Per Figure 17, attach Mist Eliminator to the Hood Assembly using hood retaining clips.
13. Per Figures 18 & 19, slide the economizer into the unit's return cavity at an angle, then push economizer flanges up against the unit's flanges, until flush. The economizer has pre-punched holes to align with the return access panel holes.
14. Using retained screws, screw economizer horizontal return flange to the unit 7 places (screw heads to be on outside). Seal the return seams with sealant.

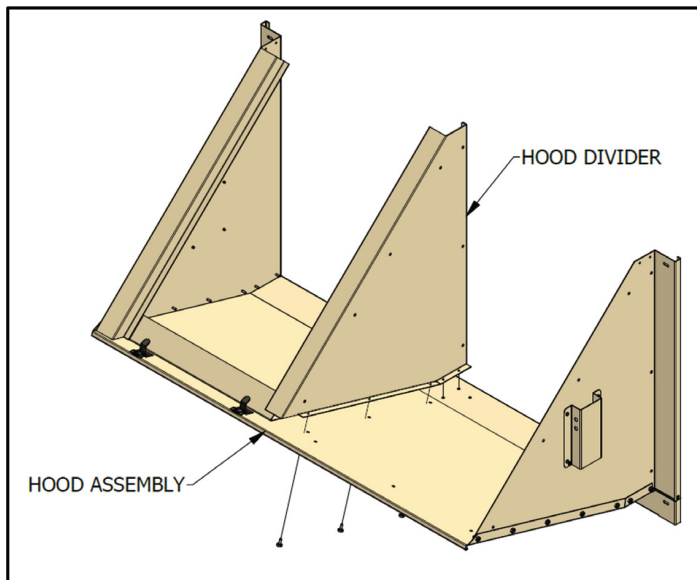
15. Per Figure 19A, screw the block-off panel through the rtu and economizer horizontal return flanges 6 places (screw heads to be on outside). Seal the return seams with sealant.
16. Per Figure 19B, block up economizer hood and screw it to the unit, picking up the economizer flanges slotted holes and the unit existing holes 4 places, using retained screws. Slide 2X Hood Leg Assemblies into their guides and attach with provided screws.



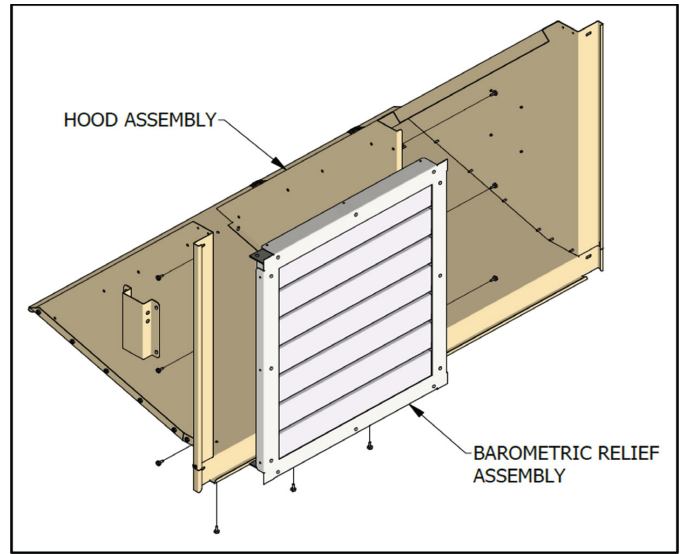
**FIGURE 11**



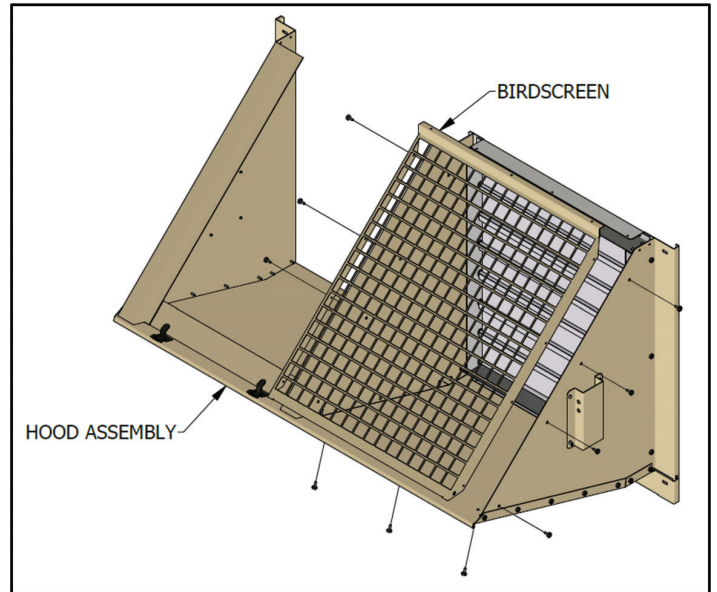
**FIGURE 12**



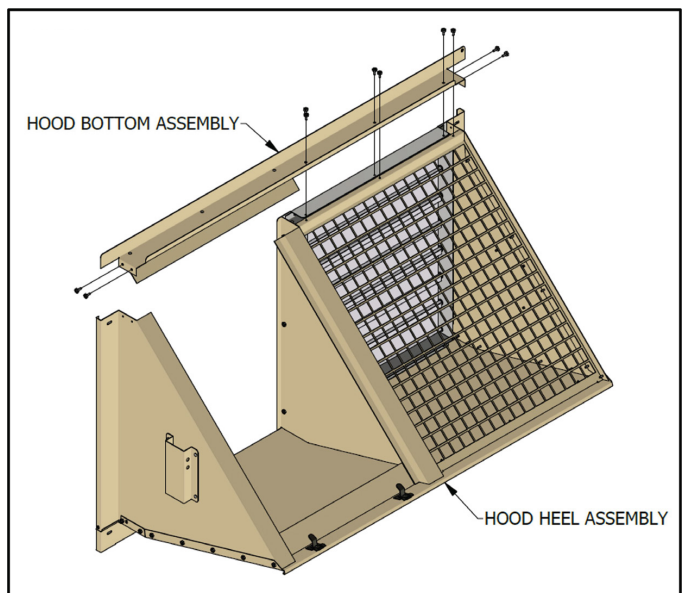
**FIGURE 13**



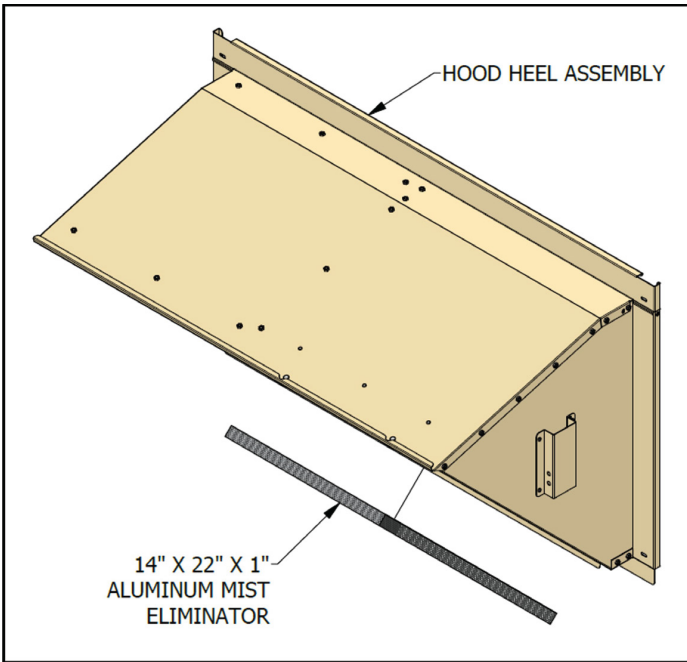
**FIGURE 14**



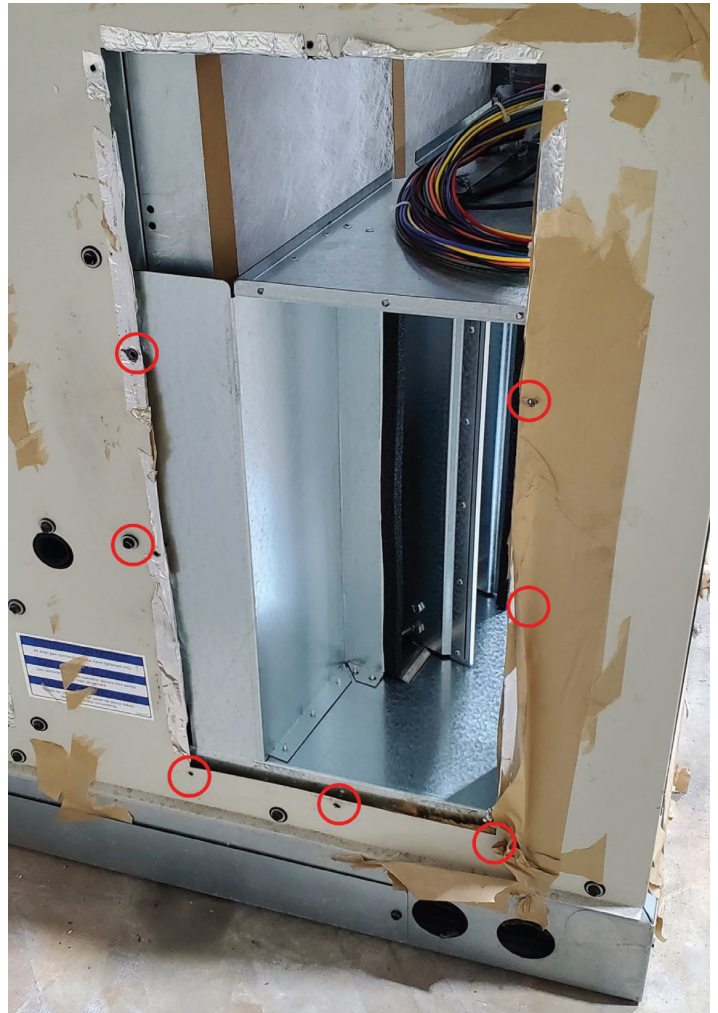
**FIGURE 15**



**FIGURE 16**



**FIGURE 17**



**FIGURE 19A**



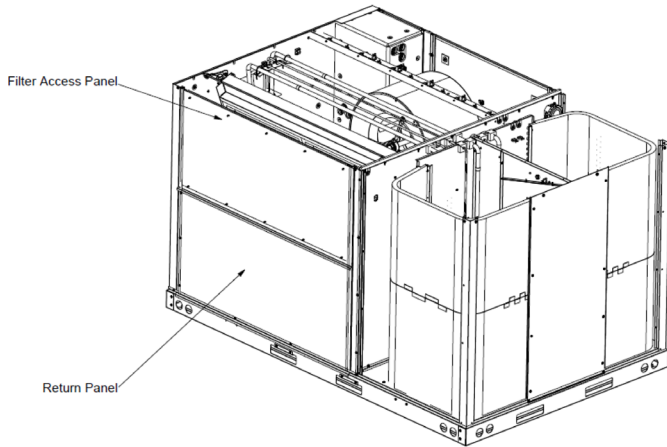
**FIGURE 18**



**FIGURE 19B**

**TO INSTALL THE 7.5 - 12.5 TON HORIZONTAL ECONOMIZER, PERFORM THE FOLLOWING PROCEDURE:**

1. Open carton and inspect contents for damaged or missing parts.
2. Take filter access panel off of unit. Keep for installation back on to unit when economizer installation is complete (see Figure 20).



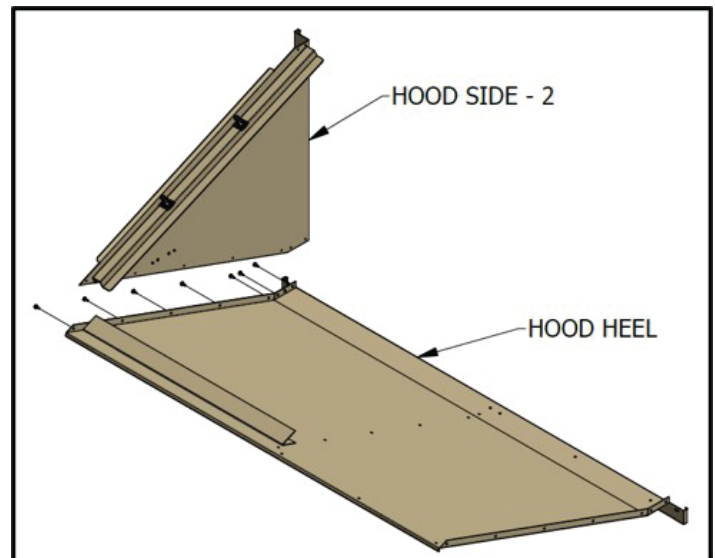
**FIGURE 20 - REMOVE PANELS**

3. Remove return panel from return air section of unit (see Figure 20). This panel can be discarded. Keep removed screws for use in later step.
4. Remove the horizontal return air opening cover and secure it over the downflow return opening per unit installation instructions (See horizontal duct clips). Keep removed screws for use in later step.
5. Mount the return air damper assembly and the outside air damper assembly to the unit using screws removed in steps 3 and 4 (see Figure 33).
6. Use provided sheet metal screws to assemble the economizer hood, Per Figure 21, attach Hood Side - 2 to the Hood Heel using 7 screws.
7. Per Figure 22, attach Hood Side - 1 to the Hood Heel using 7 screws.
8. Per Figure 23, attach Hood Divider to the Hood Assembly using 7 screws.
9. Per Figure 24, attach Hood Bottom to the Hood Assembly using 4 screws.
10. Per Figure 25, attach Bird Screen to the Hood Assembly using 17 screws.
11. Per Figure 26, attach Barometric Relief to the Hood Assembly using 12 screws.
12. Per Figure 27, attach 2X Mist Eliminators to the Hood Assembly using hood retaining clips.
13. Using the unit's horizontal access cover as a drill template, drill 12X, 1/8" dia. holes through the external horizontal duct flange (provided by others).
14. Per Figure 28, place horizontal access cover over the upflow return opening, insulation side up.
15. Per Figures 29 & 30, slide the left side of the economizer into the unit's return cavity at an angle, then push left flange flush behind the unit's flange, with the right side flange in front of the unit's flange. The economizer has pre-punched holes to align with the return access panel & horizontal duct cover holes.

16. Per Figure 31, attach the external horizontal duct flange to the unit's existing screw holes, and through the economizer return flanges and return blockoff 12X places (screw heads to be on outside). Seal the return seams with sealant.
17. Per Figure 32, attach the economizer return blockoff to the economizer frame 2X places, with supplied Tek screws.
18. Per Figures 33 & 34, block up economizer hood and screw it to the unit, picking up the economizer flange slotted holes and the unit existing holes 6X places, using retained screws. Slide 2X Hood Leg Assemblies into their guides and attach with provided screws.
19. Per Figure 35, remove the unit's jumper plug from its location on the upper right side of the unit return cavity, and tape the jumper plug to the inside wall of the return cavity, for future use. Route and plug the 12-pin economizer harness plug into matching 12-pin unit cap.

**NOTE:** Ensure the economizer harness does not interfere with the movement of the dampers during operation. Tie-wrap harness so air filters can be accessed.

20. Remove the blower access panel from the unit and locate the 2-pin MAT Sensor connector. Mount the provided Mixed Air Sensor to the blower housing per Figure 36, and plug the sensor into the 2-pin connector with the 4ft. mixed air sensor wire harness (see Wire Diagram).
21. Re-assemble the blower access panel with its screws.
22. Power the unit and use the Siemens Economizer instructions provided to configure the economizer for your application.
23. Replace filter access panel on unit.



**FIGURE 21**

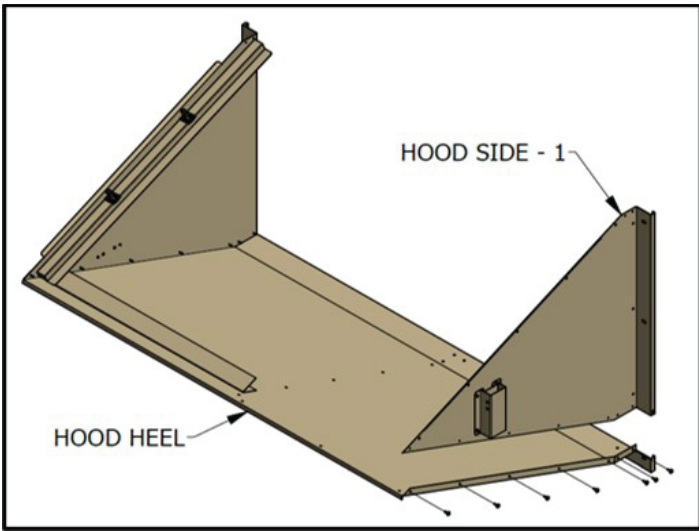


FIGURE 22

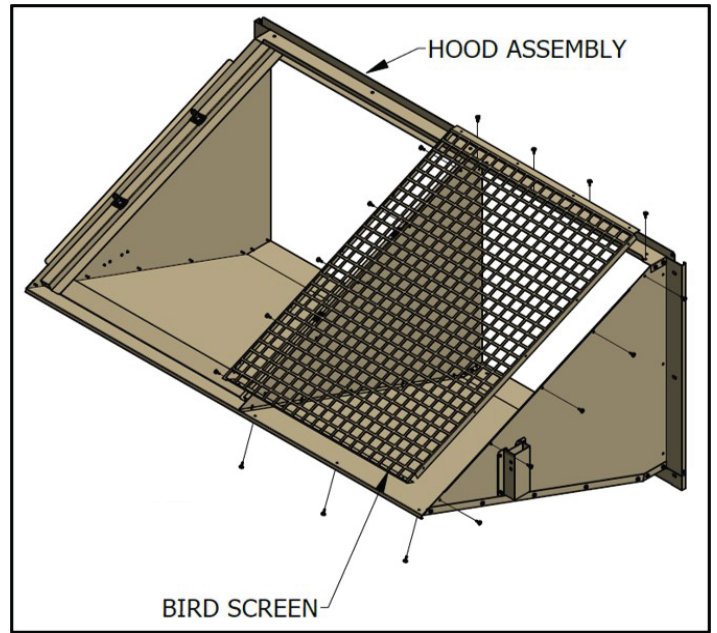


FIGURE 25

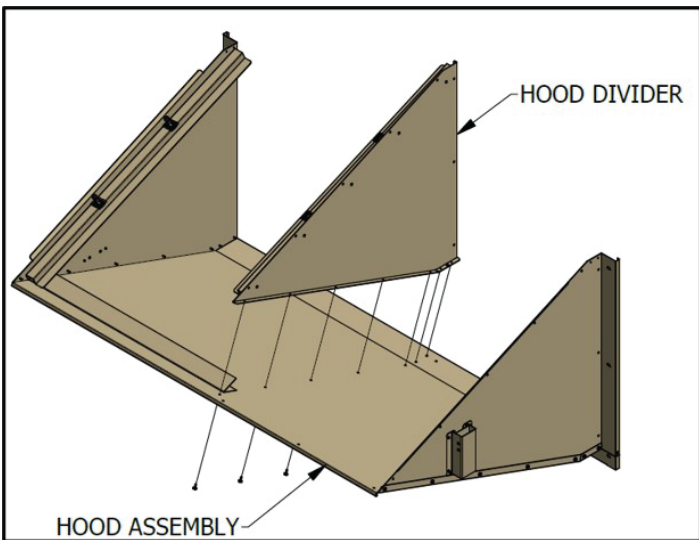


FIGURE 23

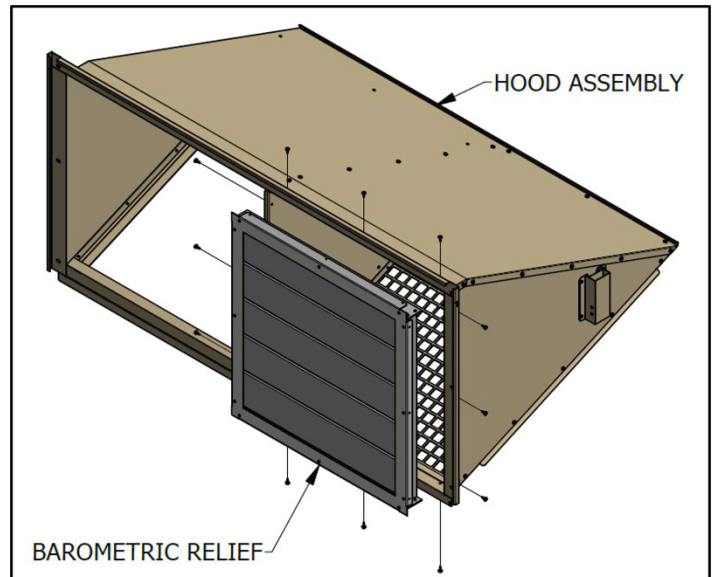


FIGURE 26

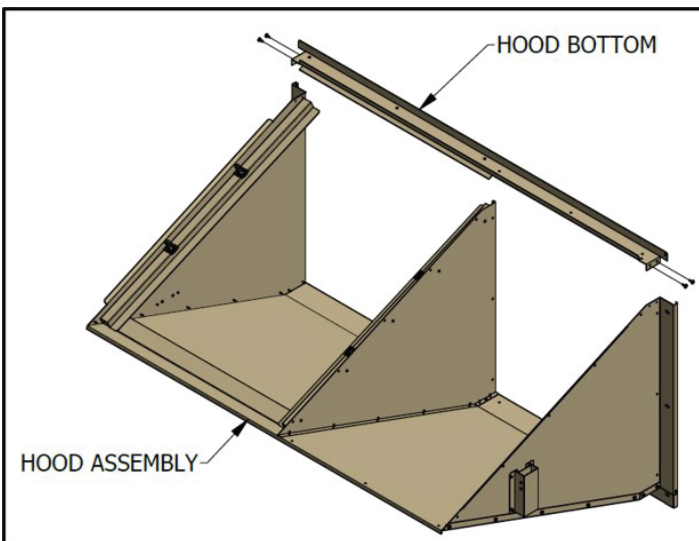


FIGURE 24

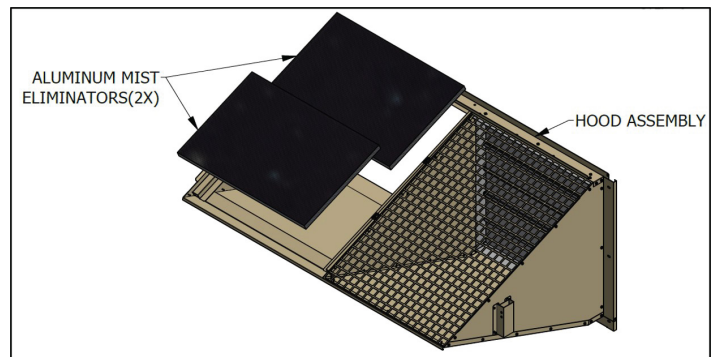


FIGURE 27



FIGURE 28



FIGURE 31

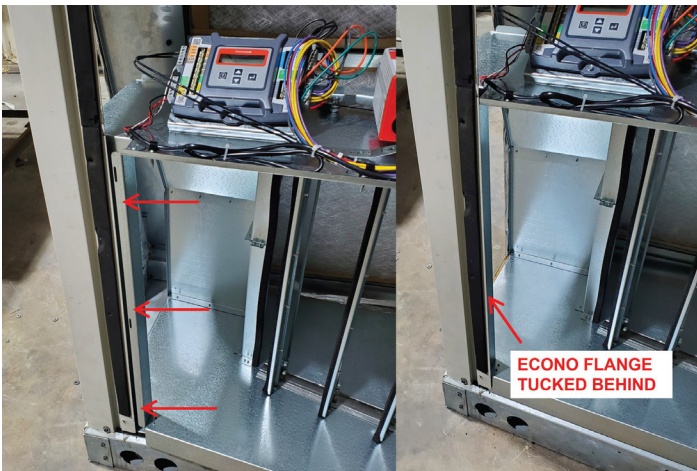


FIGURE 29

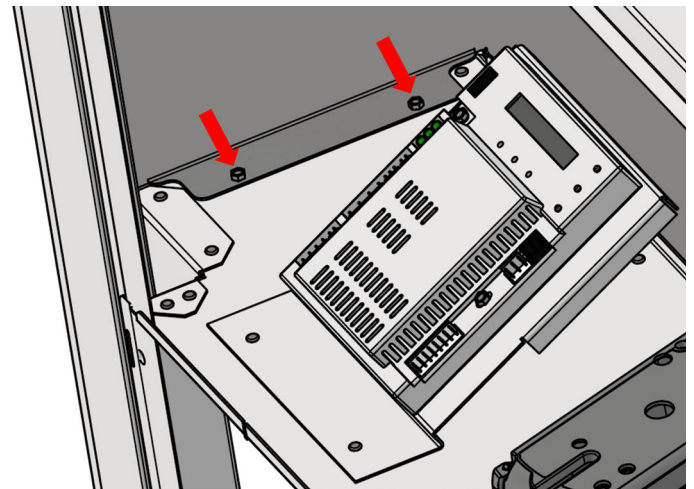


FIGURE 32

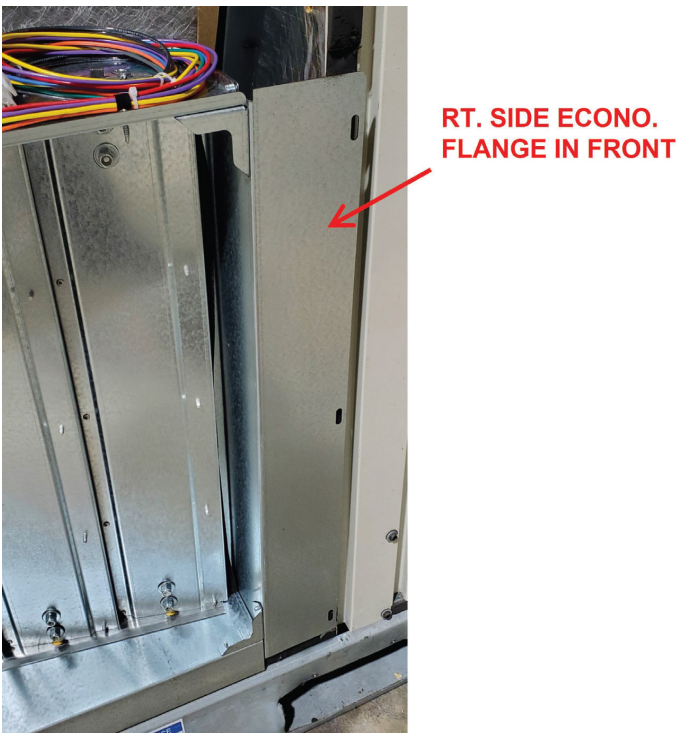
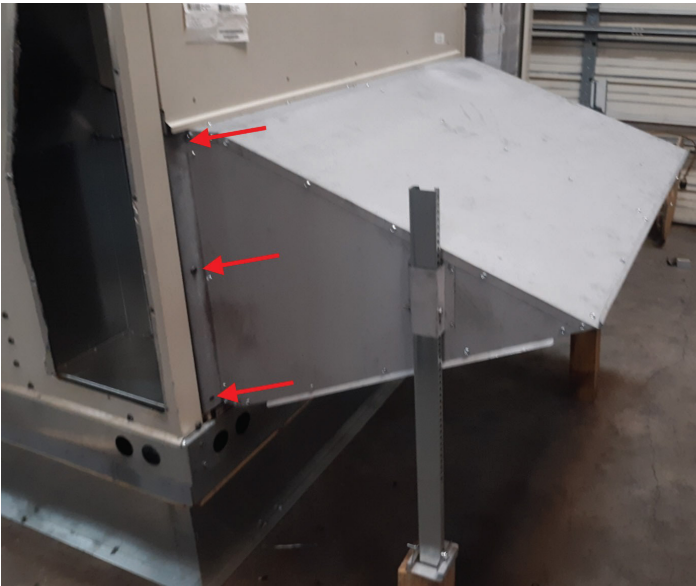


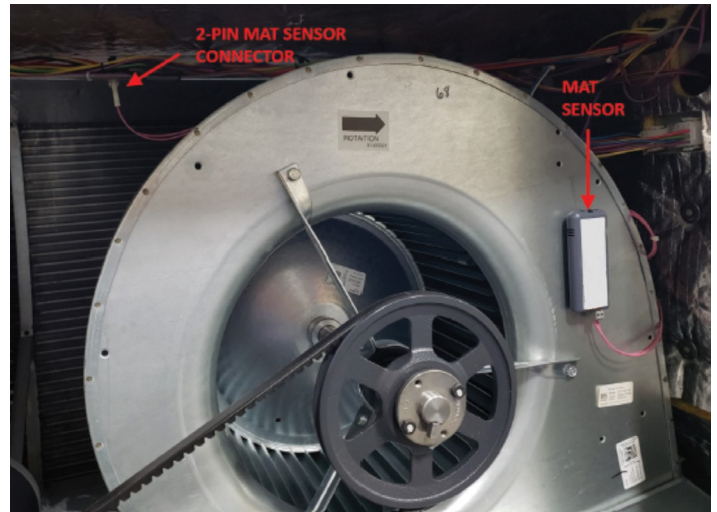
FIGURE 30



FIGURE 33

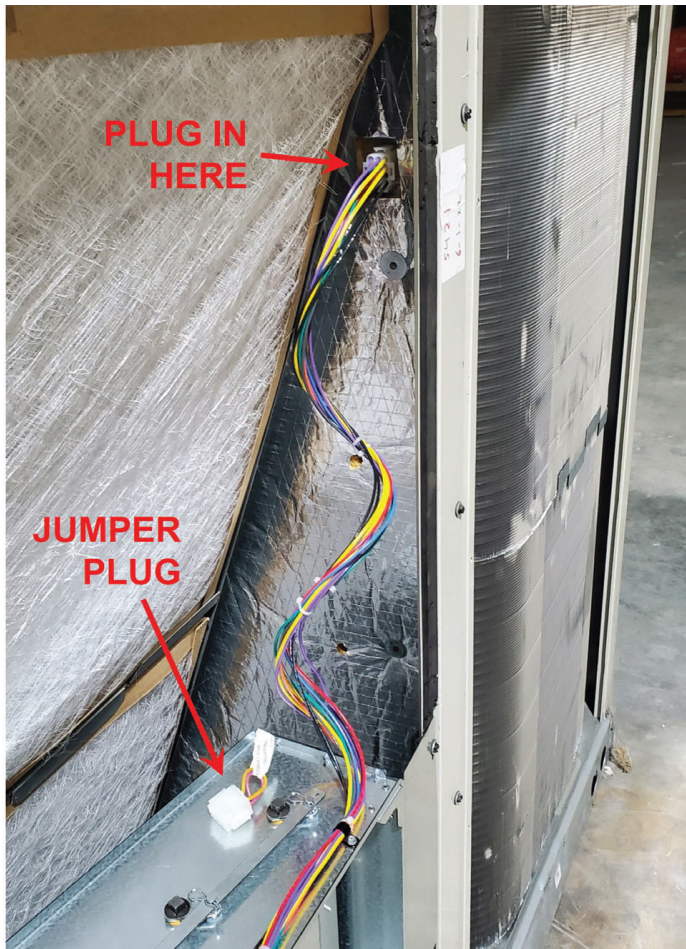


**FIGURE 34**



**FIGURE 36**

**TO INSTALL THE 7.5-12.5 TON DOWNFLOW ECONOMIZER PERFORM THE FOLLOWING PROCEDURE:**



**FIGURE 35**

1. Open carton and inspect contents for shortages and damage.
2. Remove filter and upflow access panels from package unit. Keep all screws for re-use.
3. Per Figures 37 & 38, set the economizer into the unit's return cavity, then push economizer flanges up against the unit's flanges, until flush. The economizer has pre-punched holes to align with the upflow access panel holes.
4. Apply provided foam tape to the backside of the mounting flange of Hood Sides 1 & 2. Using retained screws and per Figure 39, screw Hood Side's 1 & 2 subassy's through the top two holes (per side) of the economizer's flange to the unit's existing holes, 4 places.
5. Apply provided foam tape to the backside of the flange of the Hood Divider. Per Figure 40, attach Hood Divider to Hood Sides using 4 provided screws.
6. Apply provided foam tape to the backside of the flange of the Hood Bottom. Using retained screws and per Figure 41, attach Hood Bottom through the bottom hole (per side) of the economizer's flange to the unit's existing holes, 2 places. Attach Hood Bottom to Hood Sides using 4 provided screws.
7. Per Figure 42 & 43, attach Baffle Side to Hood Sides using 6 provided screws. Attach the Hood Baffle Front to the Divider and Baffle sides using 11 provided screws. Slide the Stabilizer Legs into place, block up underneath and bolt the two legs to the channels with provided bolts.
8. Per Figure 44, attach Hood Filter Top Stop to Hood Heel using 5 neoprene washer provided screws. Attach Hood Heel subassy to Hood Sides using 6 screws. Insert 2X Mist Eliminators into the Hood Assy, and retain with Pull-down Clips.

9. Per Figure 45, attach Hood Rain Guard to Hood Heel using 5X neoprene washer provided screws.
10. Per Figure 46, remove the unit's jumper plug from its economizer harness located on the right side, and tape the jumper plug to the inside the return cavity, for future use. Route and plug the 12-pin economizer harness into matching 12-pin unit plug.

NOTE: Ensure neither the harness nor the plugs interfere with the movement of the dampers during operation. Tie-wrap harness so air filters can be accessed.

11. Remove the blower access panel from the unit and locate the 2-pin MAT Sensor connector. Mount the provided Mixed Air Sensor to the blower housing per Figure 47, and plug the sensor into the 2-pin connector with the 4ft. mixed air sensor wire harness (see Wire Diagram) and Figure 47.
12. Re-assemble the blower access panel with its screws.
13. **Power the unit and use the Siemens Climatex ECO Economizer instructions provided and the 4 button interface on the ECO controller to configure the economizer for your application.**
14. Replace filter access panel on unit.



FIGURE 38

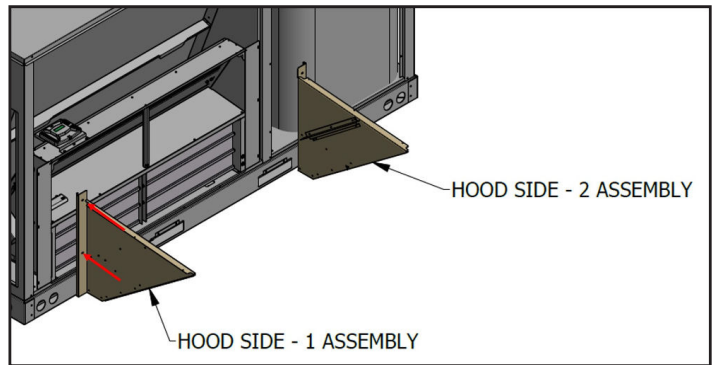


FIGURE 39

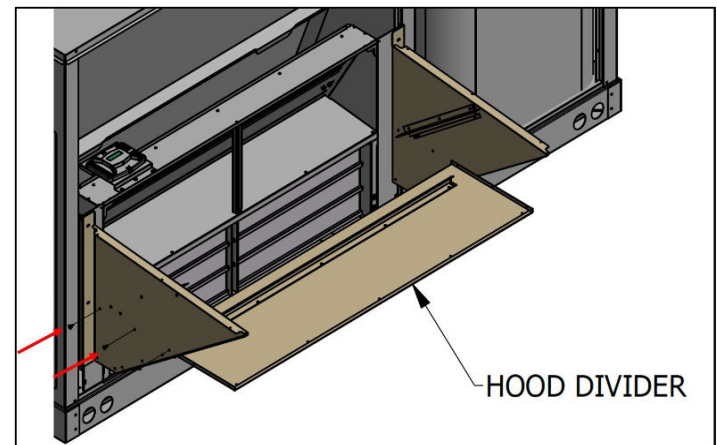


FIGURE 40

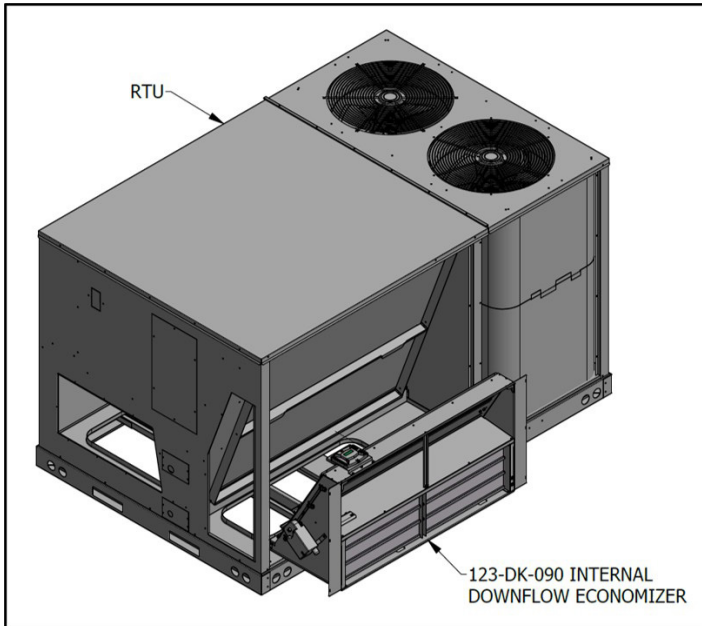
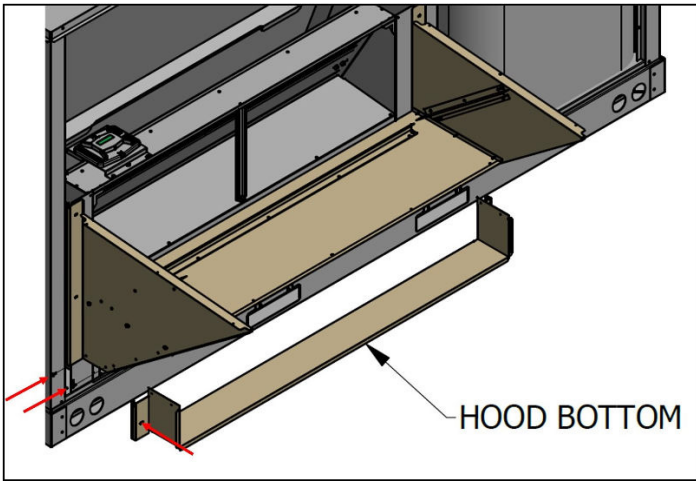
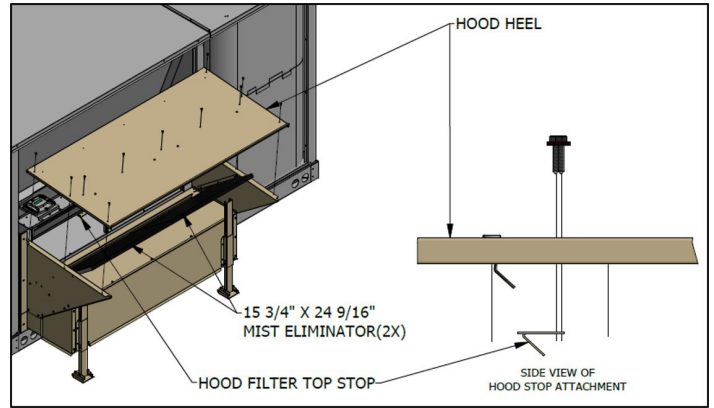


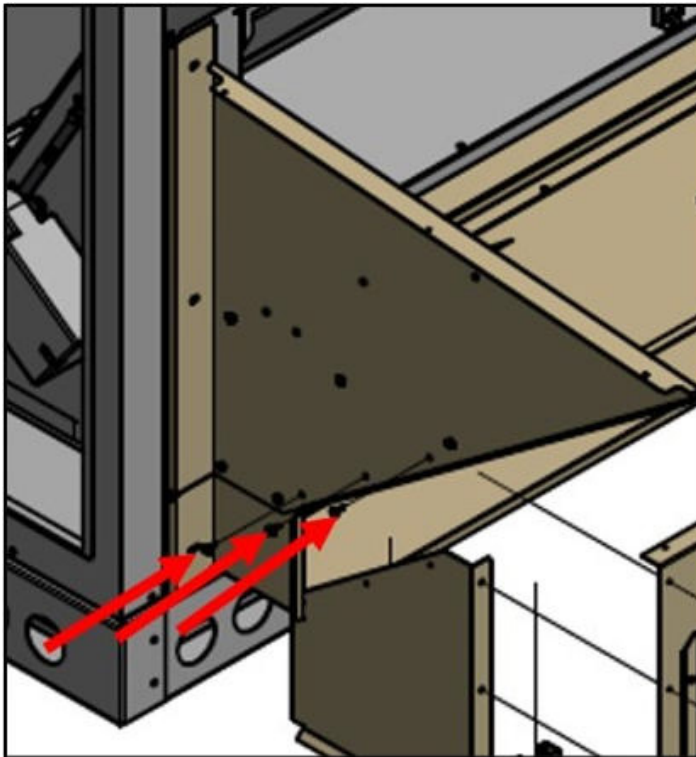
FIGURE 37



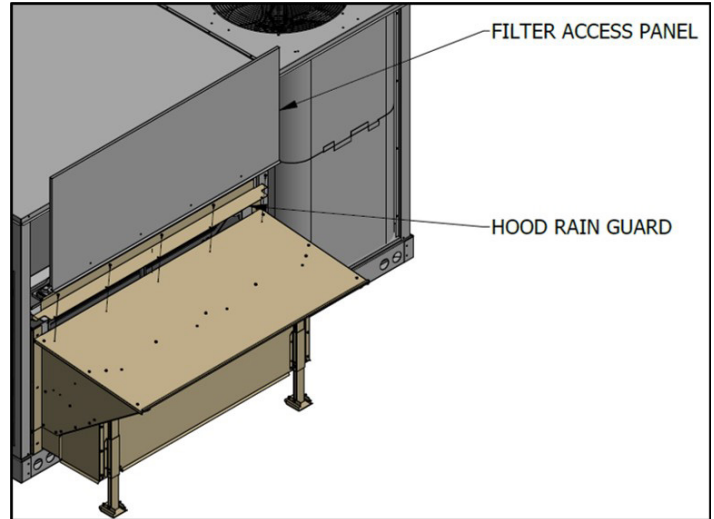
**FIGURE 41**



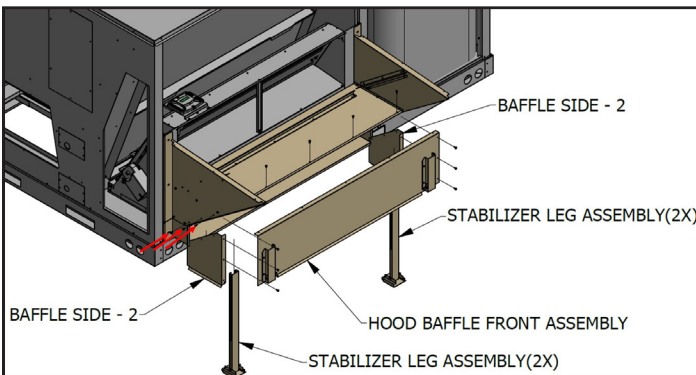
**FIGURE 44**



**FIGURE 42**



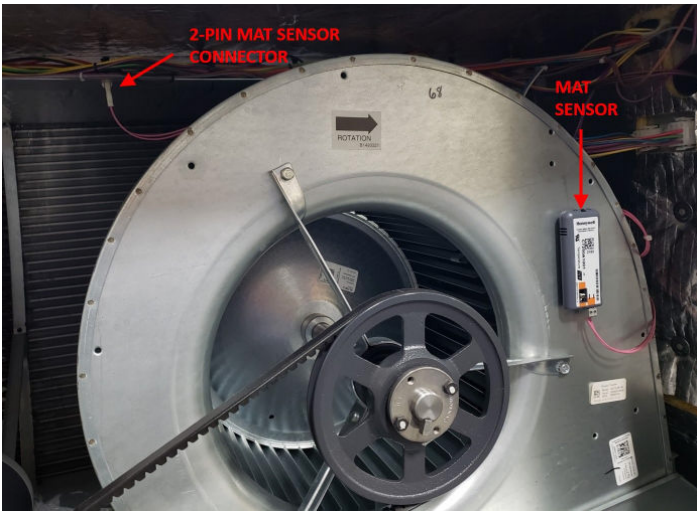
**FIGURE 45**



**FIGURE 43**



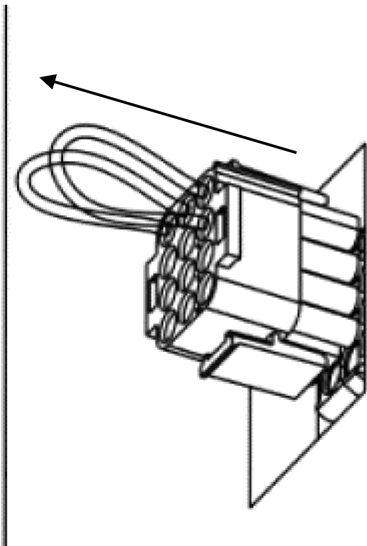
**FIGURE 46**



**FIGURE 47**

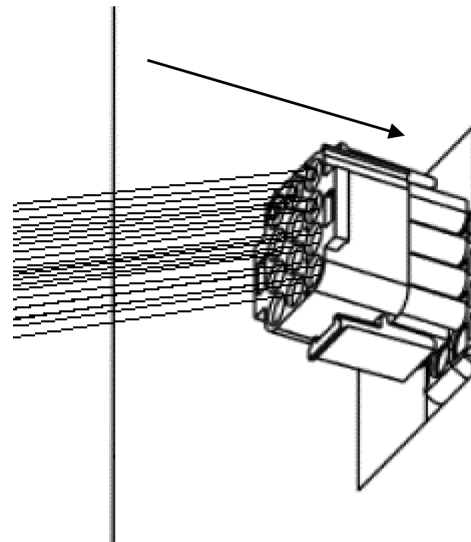
## ECONOMIZER WIRING INSTRUCTIONS

1. Remove the jumper plug from the factory installed economizer wire harness. The jumper plug is located on the partition panel in the return air compartment (see Figure 48).
2. Place Jumper Plug in basepan, do not throw away.



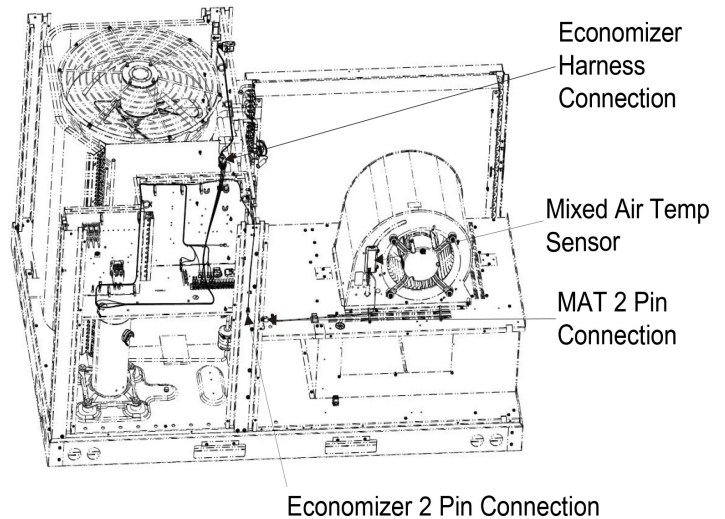
**FIGURE 48 - REMOVE JUMPER PLUG**

3. Plug in the wire harness provided with the economizer kit (see Figure 49).  
Note: Economizer kits with DDC controls do not include the mixed air temperature sensor. If your unit has the DDC controls option installed, confirm that the supply air temperature sensor has been installed and is functioning as specified in the *iLINQ* User Manual and skip to step 7.



**FIGURE 49 - ATTACH ECONOMIZER HARNESS**

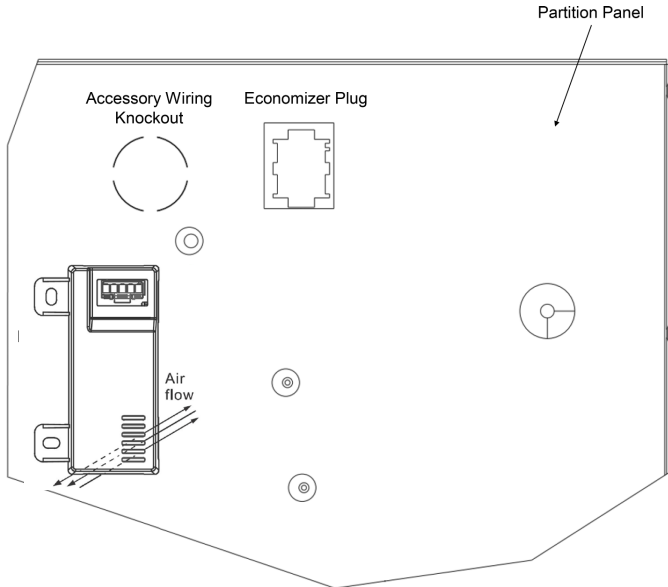
4. Remove the indoor fan compartment cover and locate the factory installed mixed air temperature harness. This harness consists of two black wires and a two pin connector. If your unit did not come with a factory installed economizer your unit will not have this harness. If your unit does not have this harness, skip to step 5. Economizer kits with DDC controls do not include the mixed air temperature sensor. If your unit has the DDC controls option installed, confirm that the supply air temperature sensor has been installed and is functioning as specified in the *iLINQ* User Manual and skip to step 7. Once the harness is located, install the mixed air temperature sensor provided with the kit on the side of the blower housing. Connect the mixed air temperature sensor to the factory harness using the adapter harness provided with the economizer kit (see Figure 50 or Figure 54). Reinstall the indoor fan compartment cover. Skip to step 6.



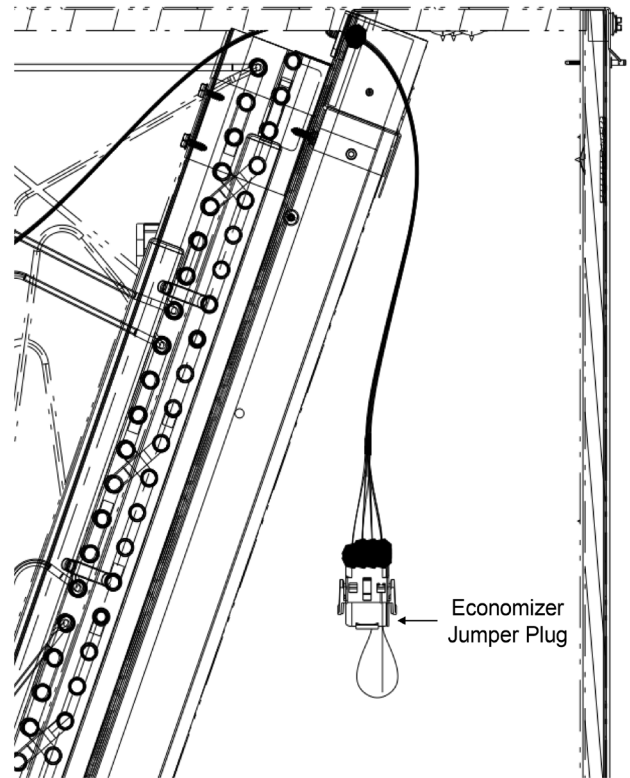
**FIGURE 50 - INDOOR FAN SECTION/MIXED AIR SENSOR FOR 3-6 TON**

- Some gas units may not have a factory installed mixed air temperature harness in the blower compartment. In this case, install the mixed air temperature sensor in the return air compartment (see Figure 51 for mounting location). Use the 2 cutting screws provided with the kit to mount the sensor. Disconnect the existing mixed air temperature sensor wire harness from the Climatex ECO control module. Locate the mixed air temperature wire harness packaged with the sensor and connect one end to the mixed air temperature sensor and the other end to the Climatex ECO module (see Figure 52). Secure the disconnected mixed air temperature harness so that it does not interfere with any moving parts.

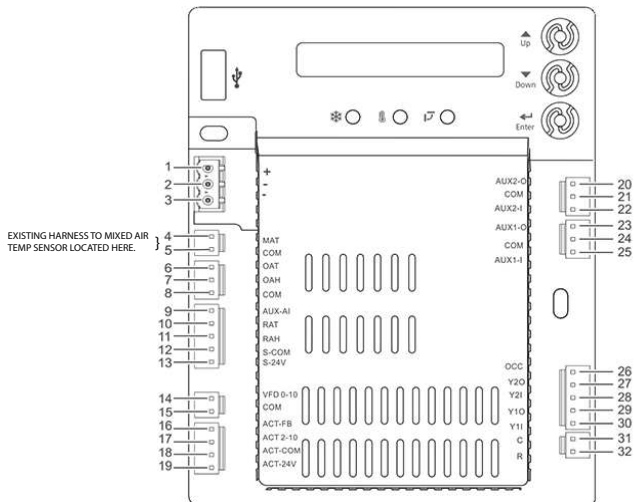
**NOTE: FOR 7.5 TO 12.5 TON UNITS, THE FACTORY INSTALLED ECONOMIZER WIRE HARNESS AND JUMPER PLUG WILL BE HANGING FROM THE EVAPORATOR COIL BLOCKOFF (SEE FIGURE 53).**



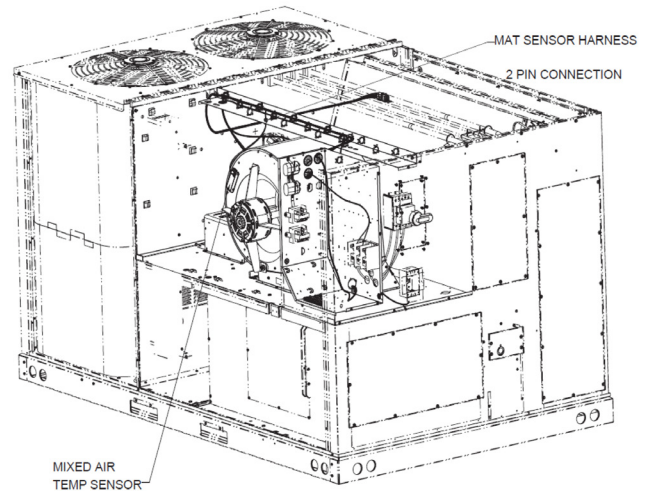
**FIGURE 51 - (FOR NON-FACTORY INSTALLED ECONOMIZER UNITS)**



**FIGURE 53**



**FIGURE 52**



**FIGURE 54 - INDOOR FAN SECTION/MIXED AIR SENSOR 7.5-12.5 TON**

- Program the Climatex ECO controller to the needs of your specific application. See included SIEMENS instructions for details of the Menu structure of the controller.
- Reinstall the unit's filter access panel above economizer.

**DOWNFLOW ECONOMIZER STATIC PRESSURE DROP VALUES:**

See the tables below for static pressure drop values when the downflow economizer kit is installed.

3-6 Tons		
Cabinet	CFM	Static Pressure Drop
3 Ton	900	.03"
	1,200	.05"
	1,500	.08"
4 Ton	1,200	.06"
	1,600	.10"
	2,000	.14"
5 Ton	1,500	.08"
	2,000	.14"
	2,500	.22"
6 Ton	1,800	.13"
	2,400	.22"
	3,000	.33"

TABLE 3

7.5-12.5 Tons		
Cabinet	CFM	Static Pressure Drop
7.5 Ton	2,250	.04"
	3,000	.07"
	3,750	.11"
8.5 Ton	2,550	.06"
	3,400	.10"
	4,250	.16"
10 Ton	3,000	.08"
	4,000	.13"
	5,000	.22"
12.5 Ton	3,750	.14"
	5,000	.24"
	6,250	.36"

TABLE 4

**HORIZONTAL ECONOMIZER STATIC PRESSURE DROP VALUES:**

See the tables below for static pressure drop values when the horizontal economizer kit is installed.

**SMALL CHASSIS ECONOMIZER STATIC PRESSURE LOSS IN. W.C.**

3-6 Tons		
Horizontal Economizer Static Pressure Drop		
Cabinet	CFM	Horizontal
3 Ton	900	.06"
	1,200	.11"
	1,500	.16"
4 Ton	1,200	.11"
	1,600	.19"
	2,000	.29"
5 Ton	1,500	.18"
	2,000	.30"
	2,500	.45"
6 Ton	1,800	.24"
	2,400	.41"
	3,000	.61"

TABLE 5 - 3-6 TON STATIC PRESSURE DROP

**MEDIUM CHASSIS ECONOMIZER STATIC PRESSURE LOSS IN. W.C.**

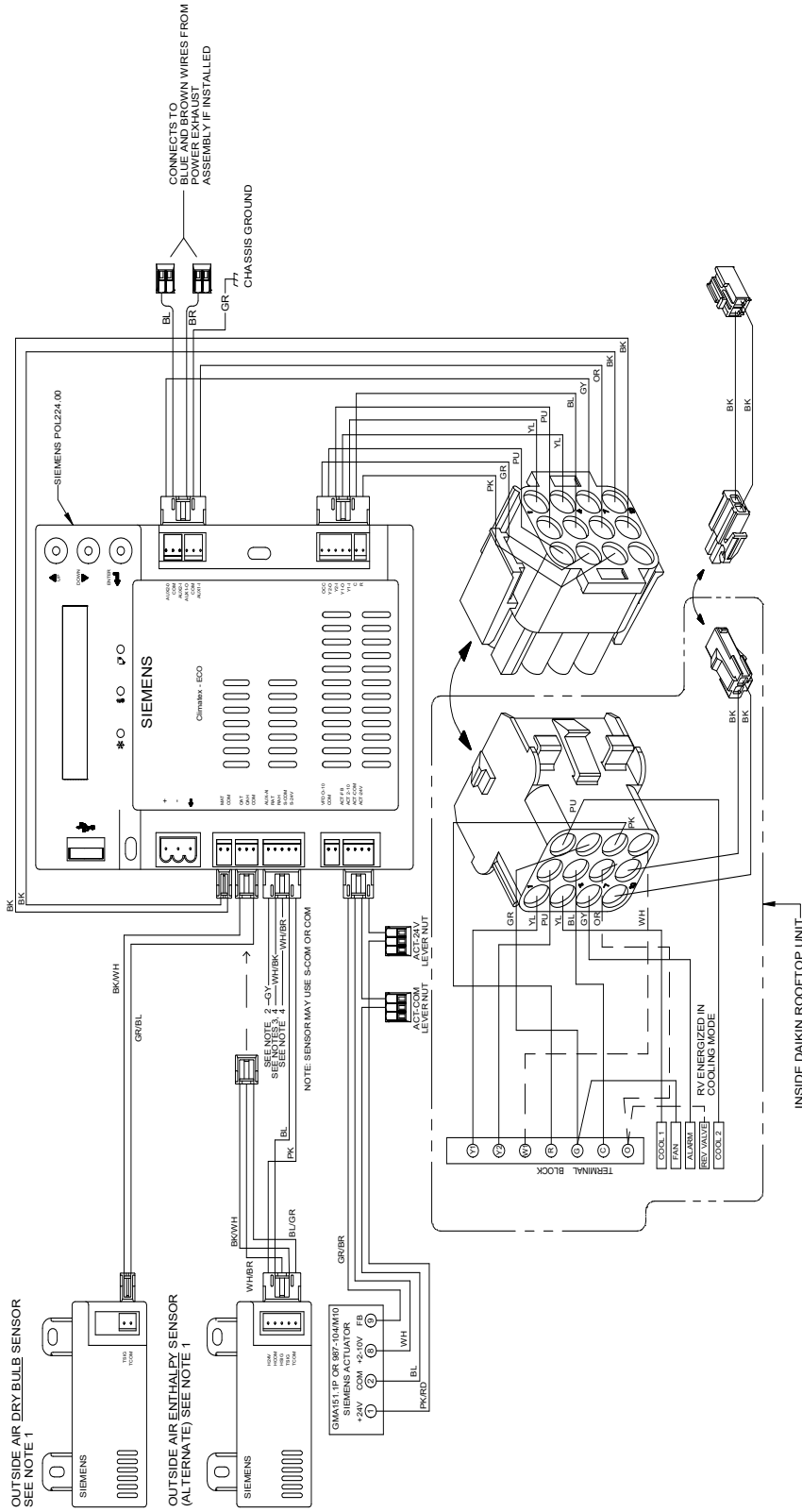
7.5 - 12.5 Tons		
Horizontal Economizer Static Pressure Drop		
Cabinet	CFM	Horizontal
7.5 Ton	2,250	.05"
	3,000	.07"
	3,750	.13"
8.5 Ton	2,550	.07"
	3,400	.13"
	4,250	.18"
10 Ton	3,000	.07"
	4,000	.12"
	5,000	.19"
12.5 Ton	3,750	.09"
	5,000	.15"
	6,250	.24"

TABLE 6 - 7.5 - 12.5 STATIC PRESSURE DROP



**WARNING**

**HIGH VOLTAGE!**  
DISCONNECT ALL POWER BEFORE SERVICING OR INSTALLING THIS UNIT. MULTIPLE POWER SOURCES MAY BE PRESENT. FAILURE TO DO SO MAY CAUSE PROPERTY DAMAGE, PERSONAL INJURY OR DEATH.



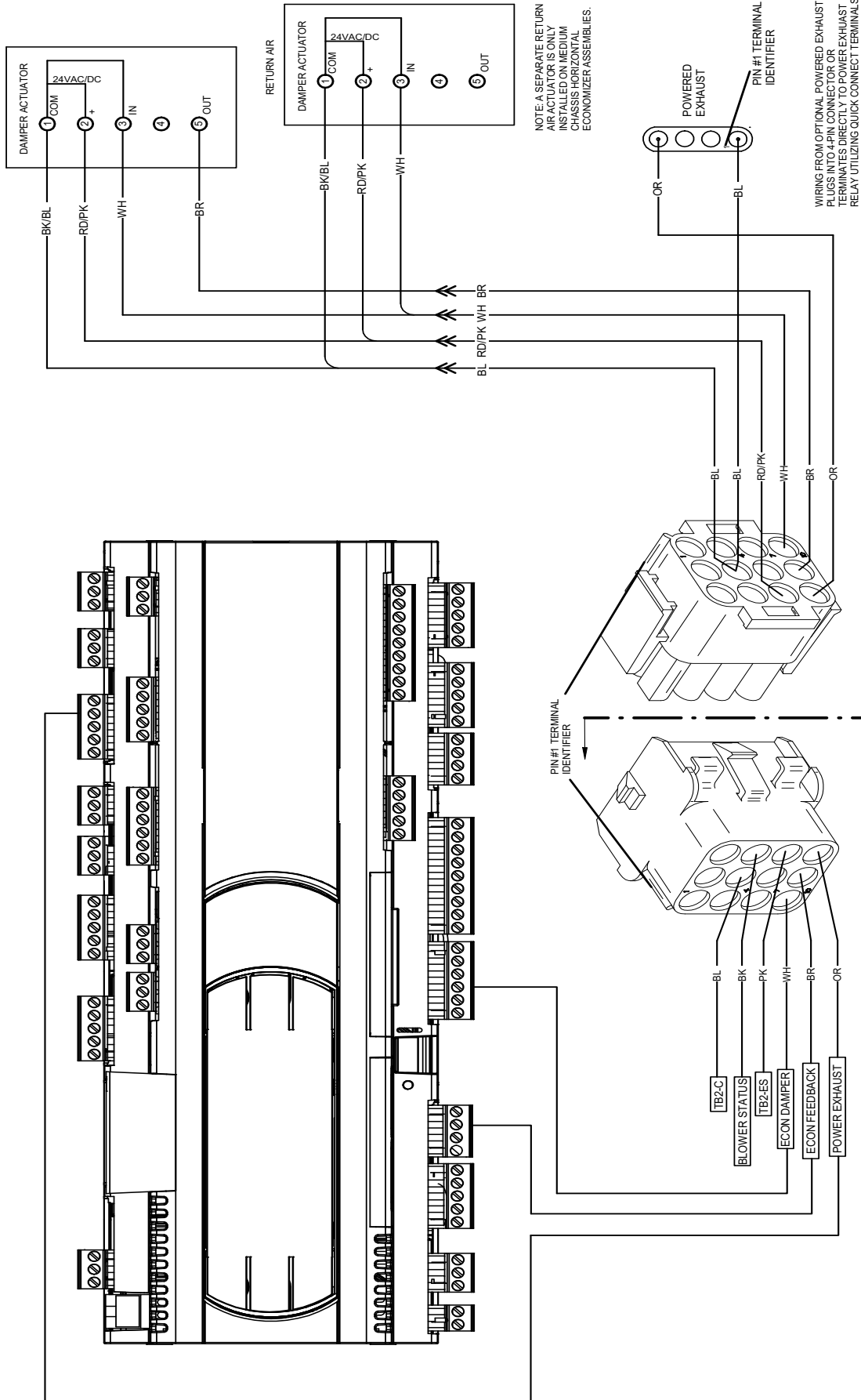
- NOTES:**
1. OUTSIDE AIR ENTHALPHY SENSOR IS AN ALTERNATE TO OUTSIDE AIR DRY BULB SENSOR (SAME MOUNT). DRY BULB SENSOR PLUGS INTO OAT & COM, AND ENTHALPHY SENSOR PLUGS INTO OAH, COM, S-COM & S-24V.
  2. AUX-WIRE LEAD AND ACT-COM LEVER NUT TO BE UTILIZED FOR CO2 OR PRESSURE SENSOR INPUT SIGNAL. ACT-COM LEVER NUT AND ACT-24V LEVER NUT TO BE UTILIZED FOR SENSOR POWER.
  3. RAT WIRE LEAD AND ACT-COM LEVER NUT TO BE UTILIZED FOR RETURN AIR TEMPERATURE SENSOR INPUT SIGNAL.
  4. RAT WIRE LEAD, RAH WIRE LEAD AND ACT-COM LEVER NUT TO BE UTILIZED FOR RETURN AIR ENTHALPHY SENSOR INPUT SIGNALS. ACT-COM LEVER NUT AND ACT-24V LEVER NUT TO BE UTILIZED FOR RETURN AIR ENTHALPHY SENSOR POWER.
  5. 'W' FOR AC AND GAS UNITS AND 'O' FOR HEAT PUMP UNITS ONLY.

# DDC ECONOMIZER WIRING DIAGRAM

**WARNING**

HIGH VOLTAGE!  
DISCONNECT ALL POWER BEFORE SERVICING OR INSTALLING THIS UNIT. MULTIPLE POWER SOURCES MAY BE PRESENT. FAILURE TO DO SO MAY CAUSE PROPERTY DAMAGE, PERSONAL INJURY OR DEATH.

NOTE: CONTROL SIGNAL FEEDBACK SET TO 2-10VDC



NOTE: A SEPARATE RETURN AIR ACTUATOR IS ONLY INSTALLED ON MEDIUM CHASSIS HORIZONTAL ECONOMIZER ASSEMBLIES.

WIRING FROM OPTIONAL POWERED EXHAUST PLUGS INTO 4-PIN CONNECTOR OR TERMINATES DIRECTLY TO POWER EXHAUST RELAY UTILIZING QUICK CONNECT TERMINALS

Wiring is subject to change. Always refer to the unit wiring diagram and accessory wiring diagram booklet for the most up-to-date wiring.

**THIS PAGE IS INTENTIONALLY LEFT BLANK**

**THIS PAGE IS INTENTIONALLY LEFT BLANK**

**CUSTOMER FEEDBACK**

Daikin is very interested in all product comments.

Please fill out the feedback form on the following link:

<https://daikincomfort.com/contact-us>

You can also scan the QR code on the right to be directed to the feedback page.



NOTE: SPECIFICATIONS AND PERFORMANCE DATA LISTED HEREIN ARE SUBJECT TO CHANGE WITHOUT NOTICE.

© 2026 Daikin Comfort Technologies Manufacturing, Inc.  
19001 Kermier Rd., Waller, TX 77484  
[www.daikincomfort.com](http://www.daikincomfort.com)