

LPKT 36150 NATURAL GAS TO LP GAS CONVERSION KIT(S) INSTALLATION INSTRUCTIONS

© 2013 **DAIKIN MANUFACTURING COMPANY, L.P.**
5151 San Felipe, Suite 500, Houston, TX 77056
www.daikincomfort.com
P/N: IOD-7009 Date: July 2013

ATTENTION INSTALLING PERSONNEL

As a professional installer you have an obligation to know the product better than the customer. This includes all safety precautions and related items.

Prior to actual installation, thoroughly familiarize yourself with this Instruction Manual. Pay special attention to all safety warnings. Often during installation or repair it is possible to place yourself in a position which is more hazardous than when the unit is in operation.

Remember, it is **your** responsibility to install the product safely and to know it well enough to be able to instruct a customer in its safe use.

Safety is a matter of common sense...a matter of thinking before acting. Most dealers have a list of specific good safety practices...follow them.

The precautions listed in this Installation Manual are intended as supplemental to existing practices. However, if there is a direct conflict between existing practices and the content of this manual, the precautions listed here take precedence.

 **RECOGNIZE THIS SYMBOL
AS A SAFETY PRECAUTION**

Description

This Natural Gas to LP Gas conversion kit allows the 36H54 (0151L00000) and 36G22 (B1282628) Series gas valves to be used on CPG light commercial LP gas applications.

Required Tools for Kit Installation	
2	Pipe Wrenches, properly sized to accommodate the gas piping and connectors
1	7/16" box wrench or socket wrench
1	5/16" Nut driver
1	1/4" regular (flatblade) screwdriver
1	3/32" Allen wrench
2	Manometers to read inlet & outlet pressure of the gas valve (Minimum range: 0" - 15" W.C.)
	Pipe joint compound or pipe thread tape
	Gas leak detection solution, like a soap and water solution. Always wipe the solution from the joints when testing is complete.

Prior to performing this conversion refer to the National Fuel Gas Code (ANSI Z223.1) or in Canada, CAN/CGA-B149.2-M91 to ensure that the installation is in compliance with those and all local codes.

Kit Contents

Using the following parts list, ensure that all parts included in this list are present and in an undamaged condition.

1	B14933-63	Conversion Label
4	0140M00096	Limit Conversion Label
1	0163F00000P	Regulator Spring Kit
1	B1880007	LP Spring Kit
1	IOD-7009	Installation Instructions
1 Pack (6 per pack)	0163L00008	Burner Orifice - #52 (LPKT 36150)
1	0130L00001	Limit

PLEASE READ AND FOLLOW THESE INSTRUCTIONS CAREFULLY.

 **WARNING**

TO AVOID THE POSSIBILITY OF EXPLOSION OR FIRE, NEVER USE A MATCH OR OPEN FLAME TO TEST FOR LEAKS.



Contents

Description	1
Kit Contents	1
IMPORTANT INFORMATION	2
NOx SCREEN REMOVAL	4
**G0360701DXXX, **G0360703DXXX, **G0480701DXXX & **G0480703BXXX MODELS ONLY	5

IMPORTANT INFORMATION



DANGER
PELIGRO



CARBON MONOXIDE POISONING HAZARD

Special Warning for Installation of Furnaces or Air Handling Units in Enclosed Areas such as Garages, Utility Rooms or Parking Areas

Carbon monoxide producing devices (such as an automobile, space heater, gas water heater, etc.) should not be operated in enclosed areas such as unventilated garages, utility rooms or parking areas because of the danger of carbon monoxide (CO) poisoning resulting from the exhaust emissions. If a furnace or air handler is installed in an enclosed area such as a garage, utility room or parking area and a carbon monoxide producing device is operated therein, there must be adequate, direct outside ventilation.

This ventilation is necessary to avoid the danger of CO poisoning which can occur if a carbon monoxide producing device continues to operate in the enclosed area. Carbon monoxide emissions can be (re)circulated throughout the structure if the furnace or air handler is operating in any mode.

CO can cause serious illness including permanent brain damage or death.

B10259-216



WARNING

HIGH VOLTAGE
DISCONNECT ALL ELECTRICAL POWER AND SHUT OFF GAS SUPPLY BEFORE SERVICING OR INSTALLING. MULTIPLE POWER SOURCES MAY BE PRESENT. FAILURE TO DO SO MAY CAUSE PROPERTY DAMAGE, PERSONAL INJURY OR DEATH.





WARNING

IF THE GAS FURNACE IS INSTALLED IN A BASEMENT, AN EXCAVATED AREA OR A CONFINED SPACE, IT IS STRONGLY RECOMMENDED TO CONTACT A PROPANE SUPPLIER TO INSTALL A GAS DETECTING WARNING DEVICE IN CASE OF A GAS LEAK.

- SINCE PROPANE GAS IS HEAVIER THAN AIR, ANY LEAKING GAS CAN SETTLE IN ANY LOW AREAS OR CONFINED SPACES.
- PROPANE GAS ODORANT MAY FADE, MAKING THE GAS UNDETECTABLE EXCEPT WITH A WARNING DEVICE.



WARNING

DAIKIN WILL NOT BE RESPONSIBLE FOR ANY INJURY OR PROPERTY DAMAGE ARISING FROM IMPROPER SERVICE OR SERVICE PROCEDURES. THIS L.P. (LIQUID PETROLEUM) CONVERSION KIT **MUST** BE INSTALLED BY A QUALIFIED SERVICE PERSON OR AGENCY IN ACCORDANCE WITH THE MANUFACTURER'S INSTRUCTIONS AND ALL APPLICABLE CODES AND REQUIREMENTS OF THE AUTHORITY HAVING JURISDICTION. FAILURE TO FOLLOW THESE INSTRUCTIONS EXPLICITLY MAY CAUSE A FIRE, EXPLOSION OR THE PRODUCTION OF CARBON MONOXIDE, WHICH CAN CAUSE PROPERTY DAMAGE, PERSONAL INJURY OR DEATH. IF YOU INSTALL OR PERFORM SERVICE ON THIS UNIT, YOU ASSUME RESPONSIBILITY FOR ANY PERSONAL INJURY OR PROPERTY DAMAGE WHICH MAY RESULT. MANY JURISDICTIONS REQUIRE A LICENSE TO INSTALL OR SERVICE HEATING AND AIR CONDITIONING EQUIPMENT.



WARNING

TO AVOID PERSONAL INJURY, PROPERTY DAMAGE OR DEATH, DUE TO LEAKING GAS, CONTACT YOUR PROPANE SUPPLIES ABOUT INSTALLING A GAS DETECTING WARNING DEVICE. IRON OXIDE (RUST) CAN REDUCE THE LEVEL OF ODORANT IN PROPANE GAS. A GAS DETECTING DEVICE IS THE ONLY RELIABLE METHOD TO DETECT A PROPANE GAS LEAK.



CAUTION

TO AVOID THE RISK OF PROPERTY DAMAGE, PERSONAL INJURY OR FIRE, SHUT OFF GAS SUPPLY FIRST, THEN DISCONNECT THE ELECTRICAL SUPPLY BEFORE PROCEEDING WITH CONVERSION.

NOTE: For low NOx models, see page 4 for NOx screens.

1. Turn off electrical power and gas supply.
2. Remove the furnace control access panel.
3. Separate the gas supply union and remove associated downstream piping.
4. Always use a backup wrench when removing or replacing piping to avoid any undue strains or rotation of controls.
5. Remove the wires from the gas valve.
6. Remove the 4 sheet metal screws that fasten the manifold/gas valve assembly to the burner box.
7. Using the 7/16" wrench, remove all existing natural gas orifices and replace with the appropriate LP gas orifices contained in this kit. Tighten the orifices to prevent gas leaks, but do not overtighten. Retain the natural gas orifices for future reconversion.
8. Reinstall the manifold/gas valve assembly into the appliance. Rewire the gas valve.
9. **Single Stage Models (36G22 valve)**

Using a 3/32" Allen wrench, loosen the inlet and outlet pressure tap screw one (1) turn only (DO NOT REMOVE). Attach a length of 5/16" hose to each of the pressure tap bosses. Connect the 5/16" hose to two (2) separate water manometers or other adequate gauges having a scale range of at least 0" to 15" of water column.

Two Stage Models (36H54 valve)

Remove both the inlet and outlet plugs on the gas valve, using the 3/16" allen wrench. Install the fittings, which accompany the manometers into the 1/8" taped holes of the gas valve. Connect the manometers to the barbed fittings.

- Using a flat blade screwdriver, remove the regulator cover screw(s).
- Remove plastic regulator adjustment screw(s) located beneath the cover screw(s).
- Remove the natural gas regulator spring(s) from the regulator sleeve(s).
- Insert the supplied LP regulator spring(s) into the regulator sleeve(s).
- Replace the regulator adjustment screw(s).
- Apply a liberal amount of pipe joint compound or pipe thread tape to the threads and reassemble the piping previously removed. Note: the pipe joint compound must be resistant to LP gas.
- Turn on the gas supply and check for leaks.

CAUTION

TO AVOID THE RISK OF PROPERTY DAMAGE, PERSONAL INJURY OR FIRE, SHUT OFF GAS SUPPLY FIRST, THEN DISCONNECT THE ELECTRICAL SUPPLY BEFORE PROCEEDING WITH CONVERSION.

- Turn on the electrical supply.
- Adjust the room thermostat to allow for constant operation. For all models using 36H54 (two stage valve), place jumper wire between W1 and W2 to ensure unit is on high fire.
- After the unit has been in operation for 15 minutes, adjust the gas supply pressure (not manifold pressure) to obtain a range between 11" and 13" W.C.
- NOTE:** Any other gas-fired equipment should be ON before any adjustments are made.
- If gas inlet pressure falls outside the range of 11" to 13" W.C., then make necessary pressure regulator adjustments, check piping size, etc., and/or consult with local utility.
- Check manifold pressure. For propane gas, the manifold pressure must be between 9.5" and 10" W.C.
- Turn adjustment screw (for two stage, the high fire adjustment screw) out (counterclockwise) to decrease pressure and in (clockwise) to increase pressure. Only small variations in gas flow should be made by means of the pressure regulator adjustment. In no case should the final manifold pressure vary more than plus or minus 0.3" water column from the specified nominal pressure. Any major changes in flow should be made by changing the size of the burner orifices. The measured input rate to the furnace must not exceed the rating specified on the unit rating plate.
- Reset all other appliances so they function normally.

25. Single Stage Models (36G22 valve)

Turn off gas and electrical supply to the furnace, remove the manometer hose from the pressure tap bosses, and tighten the inlet and outlet pressure tap screws using the 3/32" Allen wrench.

If regulator adjustment screw (removed in Step 10) is white, the gasket supplied with the kit must be installed on the regulator cover screw. The gasket is not required if the regulator adjustment screw is black.

Two Stage Models (36H54 valve)

Remove jumper wire between W1 and W2. Also remove thermostat wire to W2 to ensure unit is on low fire. Repeat steps 9-16 and 21-22.

NOTE: On low fire, the manifold pressure must be between 6.7" and 7.3" W.C.

Turn off the gas and electrical supply to the appliance, remove the pressure taps at the gas valve, reinstall the plugs using pipe joint compound or tape.

WARNING

TO AVOID THE POSSIBILITY OF EXPLOSION OR FIRE, NEVER USE A MATCH OR OPEN FLAME TO TEST FOR LEAKS.

- Replace the regulator cover screw(s) on the regulator sleeve(s).
- Attach the supplied WARNING label to the gas valve where it can be readily seen. Also attach the small round LP label to the top of the regulator cover screw.
- Turn on the gas supply and test for leaks using a soap and water solution. Repair any gas leaks. Turn on the electrical supply.
- Observe at least 3 ignition cycles to assure quick and smooth ignition and burner operation.
- Reinstall the access panels.

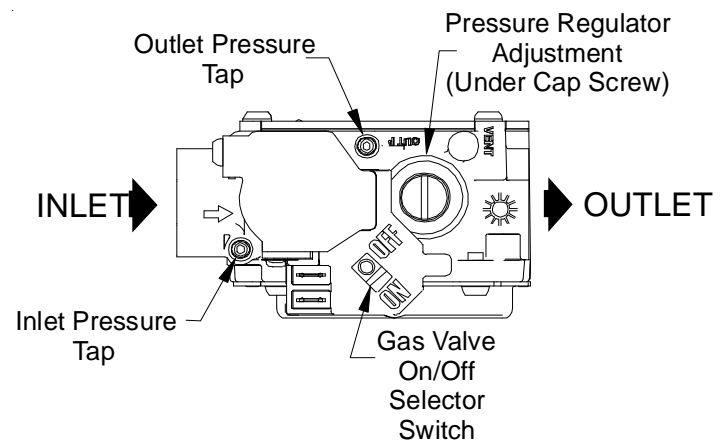

White-Rodgers 36G22 Gas Valve

NOx SCREEN REMOVAL



WARNING

REMOVE ALL METAL SCREENS FROM THE HEAT EXCHANGER TUBES WHEN USING PROPANE GAS. FAILURE TO DO SO MAY CAUSE PROPERTY DAMAGE, PERSONAL INJURY OR DEATH AND WILL VOID WARRANTY COVERAGE.

NOTE: To prevent premature heat exchanger failure, follow the instructions below to remove all metal screen inserts from the entrance of heat exchanger tubes during propane conversions. Not all models will have metal screen inserts.

1. Remove the eight screws securing the burner box to the partition panel. Separate burner box from unit.
2. Remove and discard NOx screens.
3. Reinstall the NOx screen retention plate and burner box.

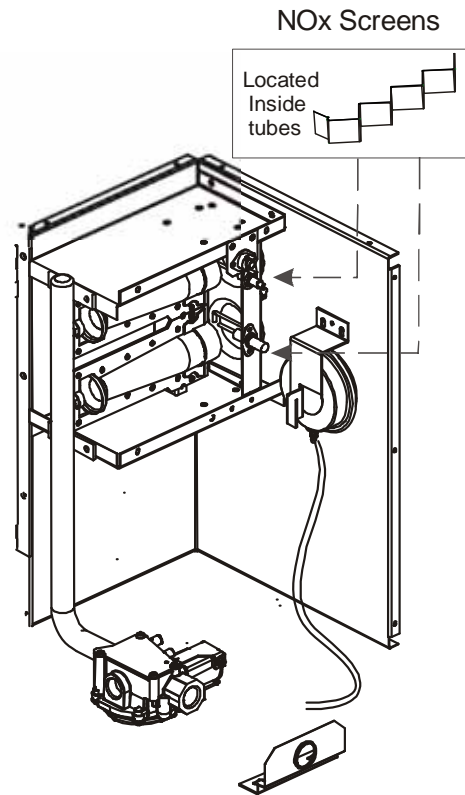

Typical NOx Screen Removal

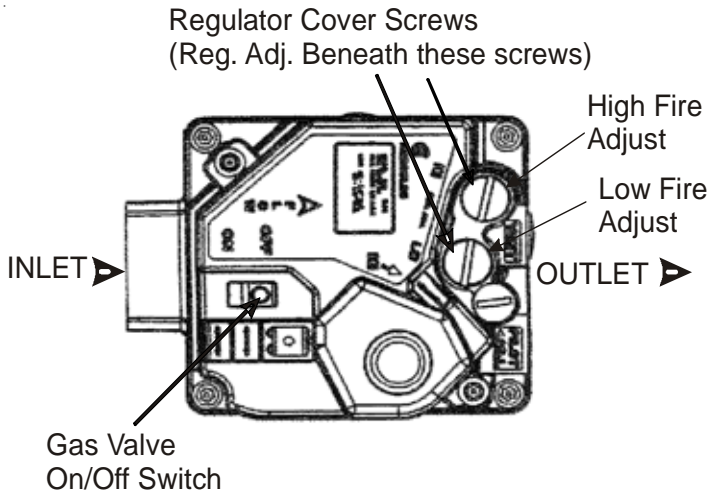

White-Rodgers 36H54 Gas Valve

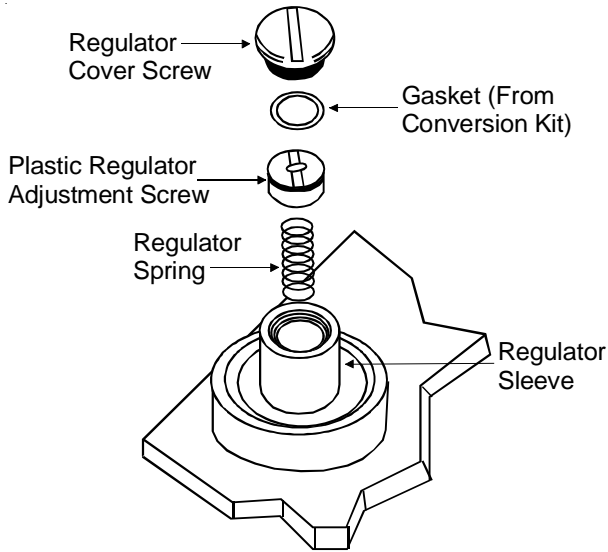

White-Rodgers 36H54 Gas Valve

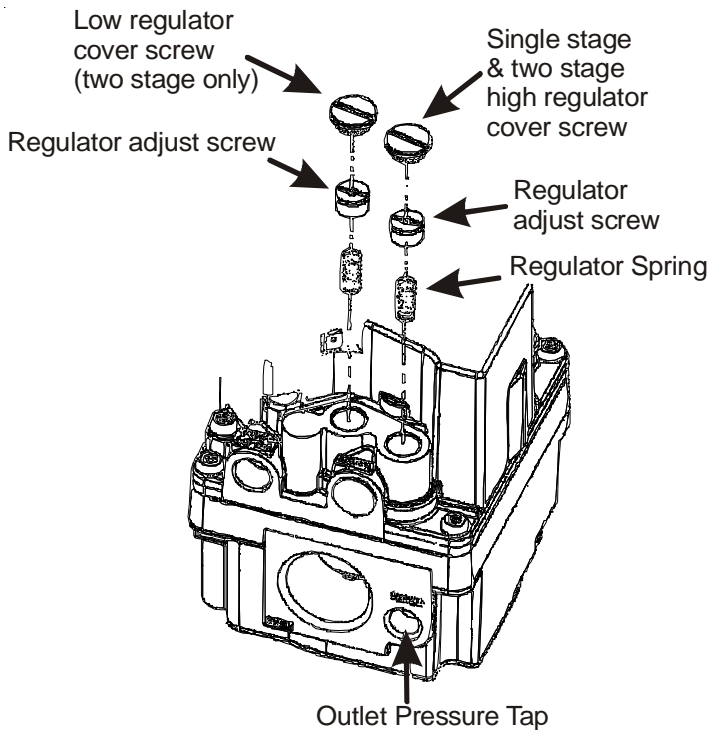

White-Rodgers 36H54 Gas Valve

****G0360701DXXX, **G0360703DXXX, **G0480701DXXX and **G0480703BXXX MODELS ONLY**

For all units converted to LP (Propane) Installations with Horizontal discharge, the main limit switch must be changed from 200°F to 180°F (Daikin part number 0130L00001).

1. Locate heat exchanger door below the control box. Remove screws attaching heat exchanger door to unit. Save screws to re-attach to door.

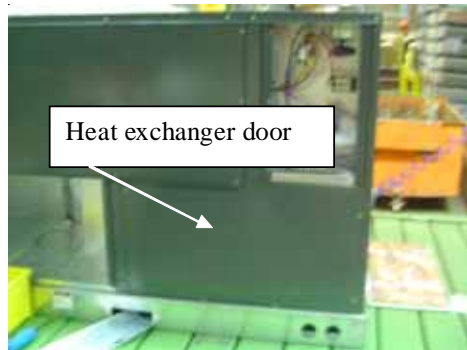

2. With door removed locate main limit/support post. Main limit will be in the center of the post.

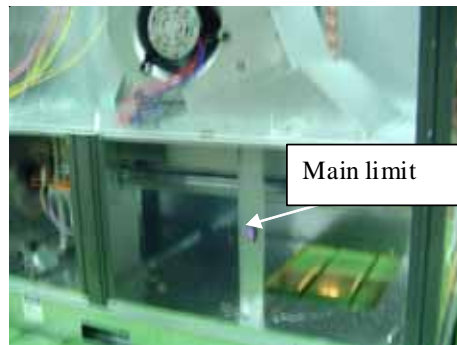

3. Remove two red wires from limit.
4. Remove two screws securing 200°F limit (part number B1370189).
5. Install supplied main limit switch (Daikin part number 0130L00001) using the two screws removed in step 4.
6. Re-attach wires removed in step 3.
7. Replace heat exchanger door using screws removed in step 1.
8. Apply the limit conversion label to the heat exchanger door or next to the rating plate.
9. Operate appliance for two cycles to ensure proper operation.

THIS PAGE LEFT INTENTIONALLY BLANK

THIS PAGE LEFT INTENTIONALLY BLANK

NOTE: SPECIFICATIONS AND PERFORMANCE DATA LISTED HEREIN ARE SUBJECT TO CHANGE WITHOUT NOTICE

Quality Makes the Difference!

All of our systems are designed and manufactured with the same high quality standards regardless of size or efficiency. We have designed these units to significantly reduce the most frequent causes of product failure. They are simple to service and forgiving to operate. We use quality materials and components. Finally, every unit is run tested before it leaves the factory. That's why we know. . . **There's No Better Quality.**

Visit our website at www.daikincomfort.com for information on:

- Products
- Warranties
- Customer Services
- Parts
- Contractor Programs and Training
- Financing Options