GSX16 Remote Condensing Unit

GSX160181FE
GSX160181FF
GSX160241FF
GSX160241FG
GSX160301FF
GSX160301FG
GSX160361FE
GSX160361FF
GSX160421FE
GSX160421FF
GSX160421FG
GSX160481FE
GSX160481FF
GSX160481FG
GSX160481FH
GSX160601FF
GSX160611FE
GSX160611FF
GSX160611FG



This manual is to be used by qualified technicians only.

This manual replaces RP-G4303A.

© 2016 , 2018 Goodman Manufacturing Company, L.P. ♦ 5151 San Felipe St, Suite 500 ♦ Houston, TX 77056

Important Information

Index

Functional Parts List	3
Illustration and Parts	4 - 9

Views shown are for parts illustrations only, not servicing procedures

Text Codes:

AR - As Required

NA - Not Available

NS - Not Shown

00000000 - See Note

QTY - Quantity Example (QTY 3) (If Quantity not shown, Quantity = 1)

M - Model Example (M1) (If M Code not shown, then part is used on all Models)

Expanded Model Nomenclature:

Example M1 - Model#1 M2 - Model#2 M3 - Model#3

Goodman Manufacturing Company, L.P. is not responsible for personal injury or property damage resulting from improper service. Review all service information before beginning repairs.

Warranty service must be performed by an authorized technician, using authorized factory parts. If service is required after the warranty expires, Goodman Manufacturing Company, L.P. also recommends contacting an authorized technician and using authorized factory parts.

Goodman Manufacturing Company, L.P. reserves the right to discontinue, or change at any time, specifications or designs without notice or without incurring obligations.

For assistance within the U.S.A. contact:
Homeowner Support
Goodman Manufacturing Company, L.P.
19001 Kermier Road
Waller, Texas 77484
877-254-4729-Telephone
713-863-2382-Facsimile

For assistance outside the U.S.A. contact:
International Division
Goodman Manufacturing Company, L.P.
19001 Kermier Road
Waller, Texas 77484
713-861-2500-Telephone
713-863-2382-Facsimile

Functional Parts

Part

No: Description:

0151R00081	7/8" BALL VALVE (M12, M13, M14, M15, M16, M17, M18, M19)
0151R00079	BASE VALVE 3/4" (M1, M2, M3, M4)
0151R00167	BASE VALVE 3/8"
0151R00080	BASE VALVE 7/8" (M5, M6, M7, M8, M9, M10, M11)
0150M00010	BLADE-FAN 26" ALUM CCW (M16)
CAP050300440CS	CAP,5/30MFD/440V/DUAL RD (M1, M2)
CAP050350440CS	CAPACITOR 5/35/440V (M3, M4)
CAP050400440CT	CAPACITOR 5/40/440V/DUAL RD (M5, M6)
CAP050450440CT	CAPACITOR 5/45/440V/DUAL RD (M7, M8, M9, M10, M11, M12, M13, M14, M15)
CAP050700440CT	CAPACITOR 5/70/440V/DUAL RD (M16, M17, M18, M19)
ZP14K5EPFV130	COMP, 14650,208/230/60/1 (M1, M2)
ZP20K5EPFV130	COMP,20000,208/230/60/1 (M3, M4)
ZP24K5EPFV130	COMP,24000,208/230/60/1 (M5, M6)
ZP29K5EPFV130	COMP,29000,208/230/60/1 (M7, M8)
ZP34K5EPFV130	COMP,34500,208/230/60/1 (M9, M10, M11)
ZP36K5EPFV130	COMP,36200,208/230/60/1 (M12, M13, M14, M15)
ZP44K5EPFV130	COMP,44400,280/230/60/1 (M16)
ZP49K5EPFV130	COMP,49400,208/230/60/1 (M17, M18, M19)
CONT1P025024V	CONTACTOR 25 AMP, 1P, 24V (M1, M2, M3, M4, M7, M8)
CONT1P030024V	CONTACTOR 30 AMP, 1P, 24V (M5, M6, M9, M10, M11, M12, M13, M14, M15, M16, M17, M18, M19)
0131M00761	ECM MOTOR - PROGRAMMED (IGBT) (M16)
0150M00008	FAN BLADE, 22" TNT2203-25 (M1, M2, M3, M4, M5, M6, M7, M8)
0163R00003	HEATER, CRANKCASE 230V 40W (M16)
0131M00061	MOTOR, 1/4HP, 1SP, 8PL (M12, M17)
0131M00807	MOTOR, 1/4HP,1SP,8PL,AL (M13, M14, M15, M18, M19)
0131M00753	MOTOR, 1/6HP, 1SP, 8PL, AL (M1, M2, M3, M4, M5, M6, M7, M8, M9, M10, M11)

Expanded Model Nomenclature

M1 - GSX160181FE
M2 - GSX160181FF
M3 - GSX160241FF
M4 - GSX160241FG
M5 - GSX160301FF
M6 - GSX160301FG
M7 - GSX160361FE
M8 - GSX160361FF
M9 - GSX160421FE
M10 - GSX160421FF
M11 - GSX160421FG
M12 - GSX160481FE
M13 - GSX160481FF
M14 - GSX160481FG
M15 - GSX160481FH
M16 - GSX160601FF
M17 - GSX160611FE
M18 - GSX160611FF
M19 - GSX160611FG

SPECIAL PARTS

0161R00088	CAP, GRILL (M16)
0161R00092	NAMEPLATE, GOODMAN

Control Box Assembly

CONTROL BOX PANEL
REFERENCE ONLY

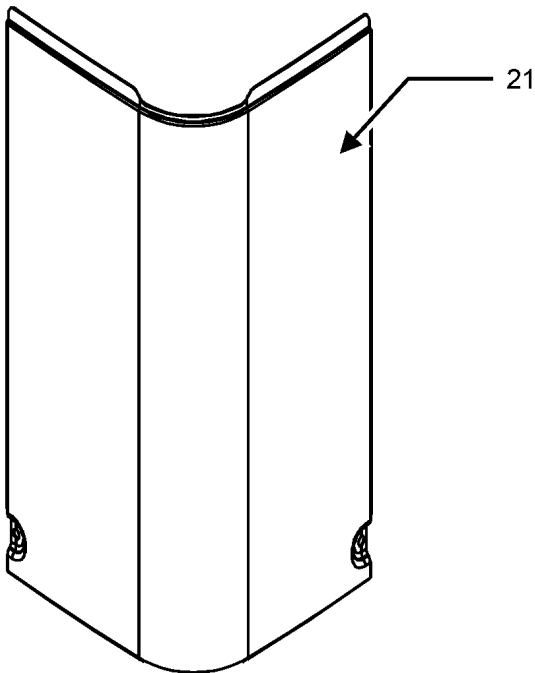
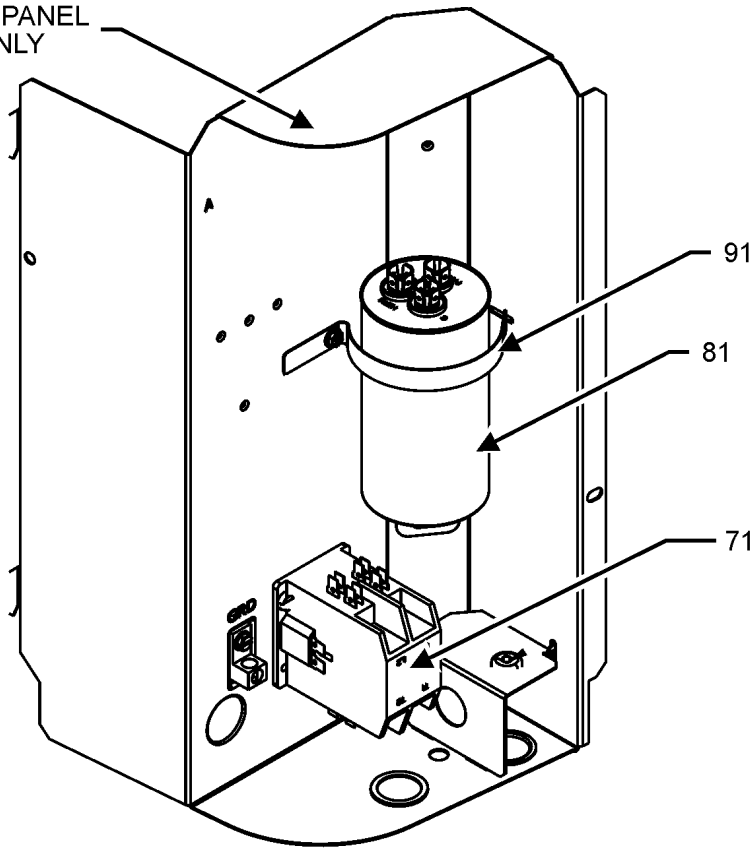

UPPER ACCESS PANEL

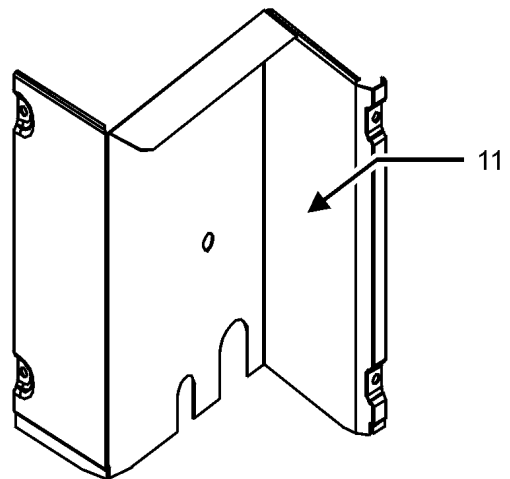

LOWER ACCESS PANEL

Control Box Assembly

Ref. Part No: No:	Description:	Ref. Part No: No:	Description:
-------------------	--------------	-------------------	--------------

Image 1:

11	0121R00316PDG	PANEL, LOWER ACCESS PNT (M7, M8, M12, M13, M14, M15, M17, M18, M19)
11	0121R00318PDG	PANEL, LOWER ACCESS PNT (M16)
11	0121R00319PDG	PANEL, LOWER ACCESS PNT (M5, M6, M9, M10, M11)
11	0121R00663PDG	PANEL, LOWER ACCESS PNT (M1, M2, M3, M4)
21	0121R00053PDG	CONTROL COVER
71	CONT1P025024V	CONTACTOR 25 AMP, 1P, 24V (M1, M2, M3, M4, M7, M8)
71	CONT1P030024V	CONTACTOR 30 AMP, 1P, 24V (M5, M6, M9, M10, M11, M12, M13, M14, M15, M16, M17, M18, M19)
81	CAP050300440CS	CAP,5/30MFD/440V/DUAL RD (M1, M2)
81	CAP050350440CS	CAPACITOR 5/35/440V (M3, M4)
81	CAP050400440CT	CAPACITOR 5/40/440V/DUAL RD (M5, M6)
81	CAP050450440CT	CAPACITOR 5/45/440V/DUAL RD (M7, M8, M9, M10, M11, M12, M13, M14, M15)
81	CAP050700440CT	CAPACITOR 5/70/440V/DUAL RD (M16, M17, M18, M19)
91	4400065	CAPACITOR STRAP
NS	0161R00092	NAMEPLATE, GOODMAN

Expanded Model Nomenclature

M1 - GSX160181FE
M2 - GSX160181FF
M3 - GSX160241FF
M4 - GSX160241FG
M5 - GSX160301FF
M6 - GSX160301FG
M7 - GSX160361FE
M8 - GSX160361FF
M9 - GSX160421FE
M10 - GSX160421FF
M11 - GSX160421FG
M12 - GSX160481FE
M13 - GSX160481FF
M14 - GSX160481FG
M15 - GSX160481FH
M16 - GSX160601FF
M17 - GSX160611FE
M18 - GSX160611FF
M19 - GSX160611FG

Cabinet Top and Side Panel Assy

TOP PANEL ASSEMBLY

TOP VIEW

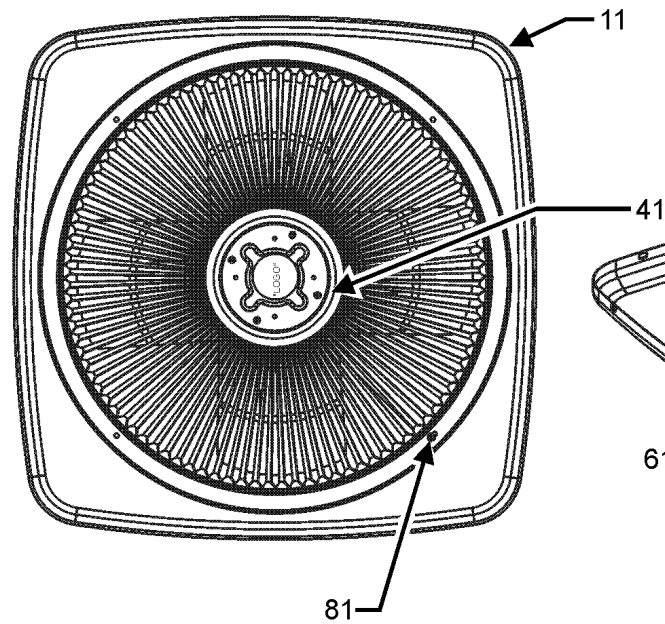

SIDE VIEW

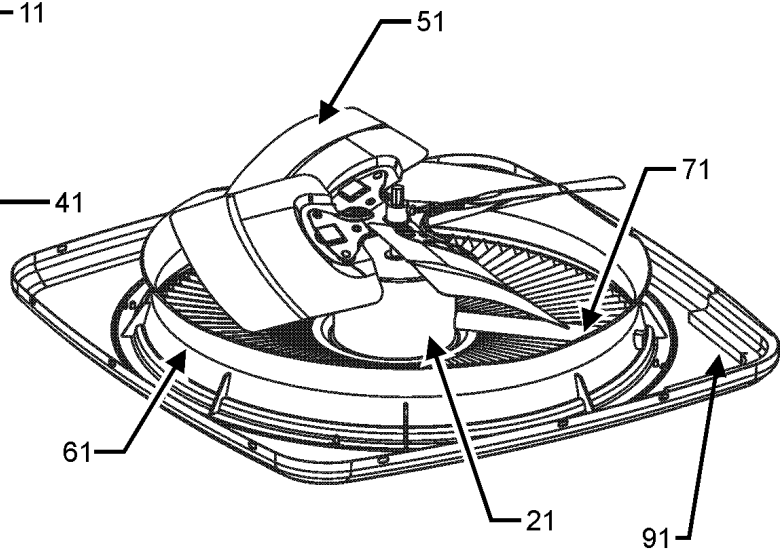

TOP VIEW

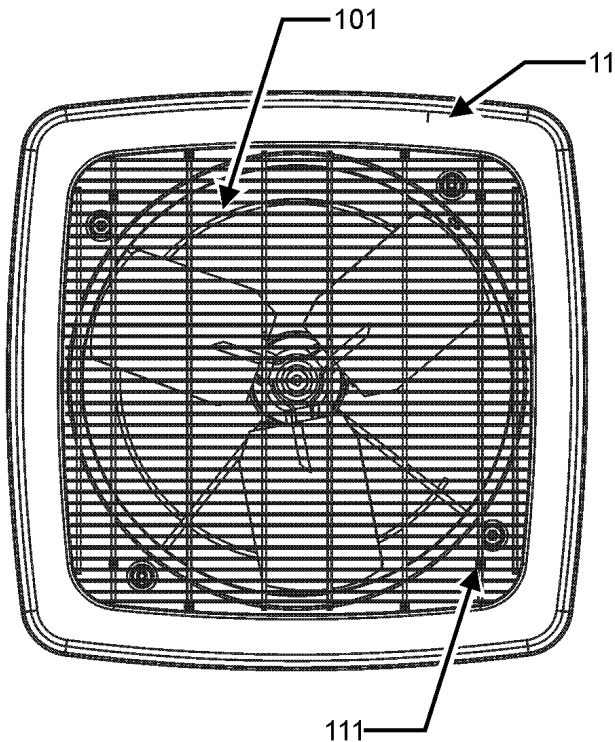

BOTTOM VIEW

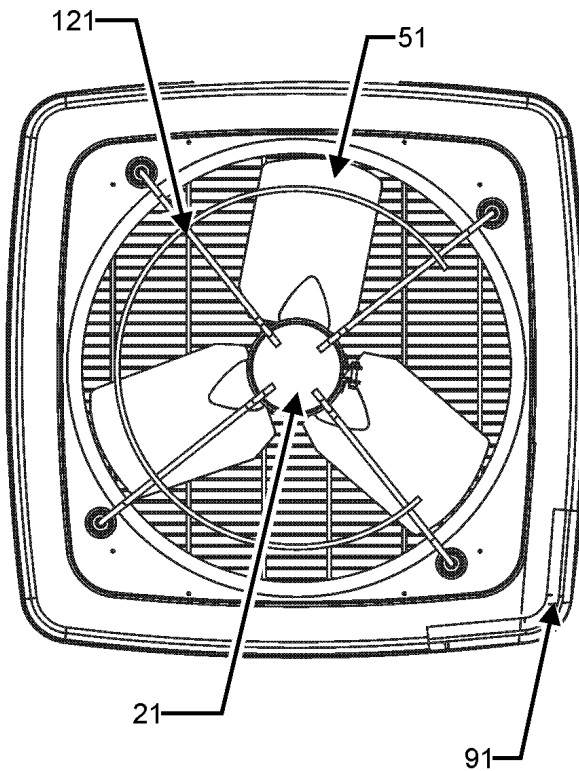

Cabinet Top and Side Panel Assy

Ref. Part No:	Description:	Ref. Part No:	Description:
<i>Image 1:</i>		Expanded Model Nomenclature	
11	0121R00010PDG TOP PANEL 29" (M1, M2, M3, M4, M5, M6, M7, M8)	M1 - GSX160181FE	
11	0121R00269PDG Top Panel, 35" Pnt (M9, M10, M11, M12, M13, M14, M15, M17, M18, M19)	M2 - GSX160181FF	
11	0121R00013PDG VENTURI TOP PANEL 35" (M16)	M3 - GSX160241FF	
21	0131M00061 MOTOR, 1/4HP, 1SP, 8PL (M12, M17)	M4 - GSX160241FG	
21	0131M00753 MOTOR, 1/6HP, 1SP, 8PL, AL (M1, M2, M3, M4, M5, M6, M7, M8, M9, M10, M11)	M5 - GSX160301FF	
31	0131M00761 ECM MOTOR - PROGRAMMED (IGBT) (M16)	M6 - GSX160301FG	
31	0131M00807 MOTOR, 1/4HP,1SP,8PL,AL (M13, M14, M15, M18, M19)	M7 - GSX160361FE	
41	0163M00006P ACORN NUT 5/16 HEX BLACK (M1, M2, M3, M4, M5, M6, M7, M8, M9, M10, M11, M12, M13, M14, M15, M17, M18, M19)	M8 - GSX160361FF	
51	0150M00010 BLADE-FAN 26" ALUM CCW (M16)	M9 - GSX160421FE	
51	10625738 BLADE-FAN 26" ALUM CCW (M12, M17)	M10 - GSX160421FF	
51	0150M00008 FAN BLADE, 22" TNT2203-25 (M1, M2, M3, M4, M5, M6, M7, M8)	M11 - GSX160421FG	
51	0150M00054 FAN BLADE, 26" (M9, M10, M11, M13, M14, M15, M18, M19)	M12 - GSX160481FE	
61	0161L00000 VENTURI RING 22" (M1, M2, M3, M4, M5, M6, M7, M8)	M13 - GSX160481FF	
61	0161R00007P VENTURI RING 35" (M9, M10, M11, M12, M13, M14, M15, M17, M18, M19)	M14 - GSX160481FG	
71	0161R00002P CONDUIT (M1, M2, M3, M4, M5, M6, M7, M8)	M15 - GSX160481FH	
71	0161R00004P CONDUIT (M9, M10, M11, M12, M13, M14, M15, M17, M18, M19)	M16 - GSX160601FF	
81	0163M00004 SCREW #10X3/4", BLACK (M1, M2, M3, M4, M5, M6, M7, M8, M9, M10, M11, M12, M13, M14, M15, M17, M18, M19)	M17 - GSX160611FE	
91	0154R00006 GASKET, CONTROL PANEL	M18 - GSX160611FF	
101	0152R00016 GRILLE, WIRE 35" TOP (M16)	M19 - GSX160611FG	
111	0163M00003P SCREW,#10 X 1/2,A,SLOT,SR,BLK (M16)		
121	0121R00003 BRACKET, MOTOR MOUNT (M16)		
NS	0161R00088 CAP, GRILL (M16)		
NS	B1393024 LOCK NUT (M16)		
NS	B1393804 NYLON LOCKNUT, .31 - 18 (M16)		
NS	0163M00129 SCREW H2 .31 X 1.52 (M16)		
NS	0163M00005P WASHER, BLACK (.50 OD .218D) (M1, M2, M3, M4, M5, M6, M7, M8, M9, M10, M11, M12, M13, M14, M15, M17, M18, M19)		

Compressor and Tubing Assembly

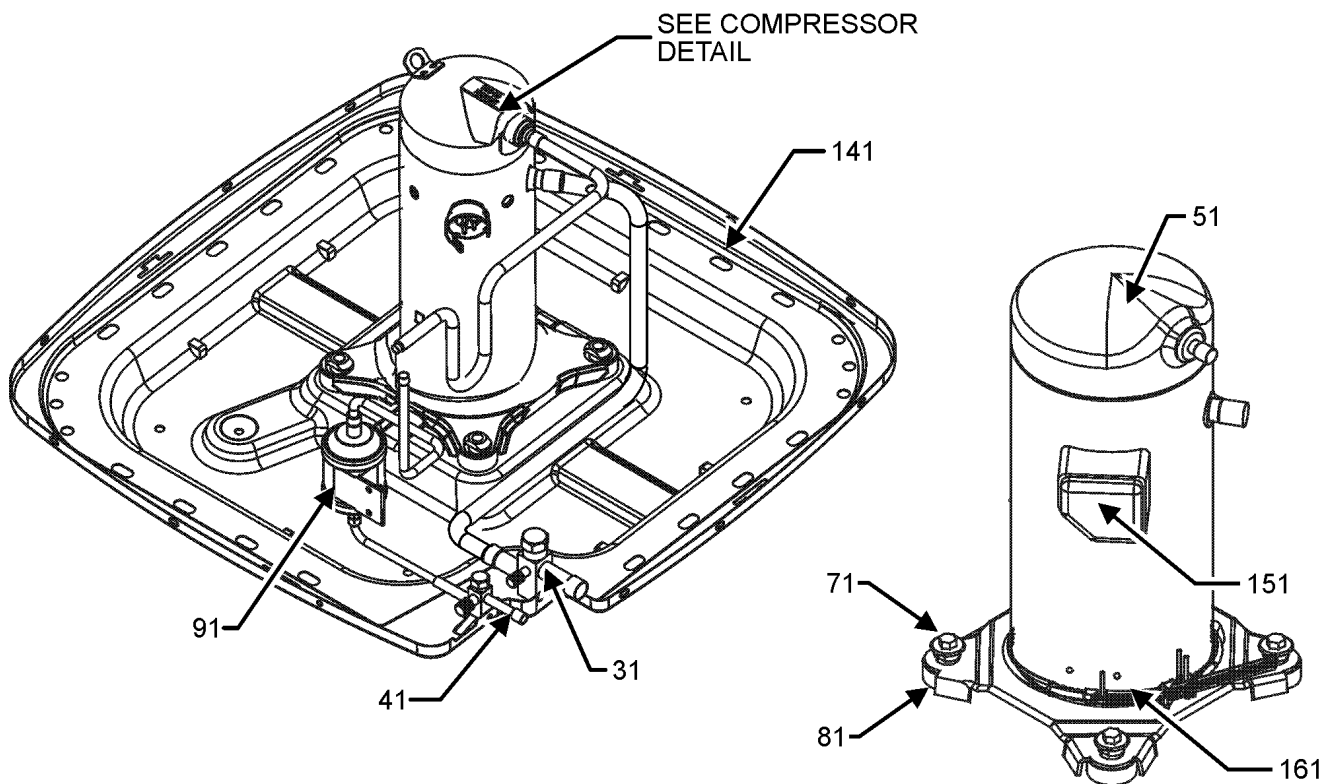

COMPRESSOR
DETAIL

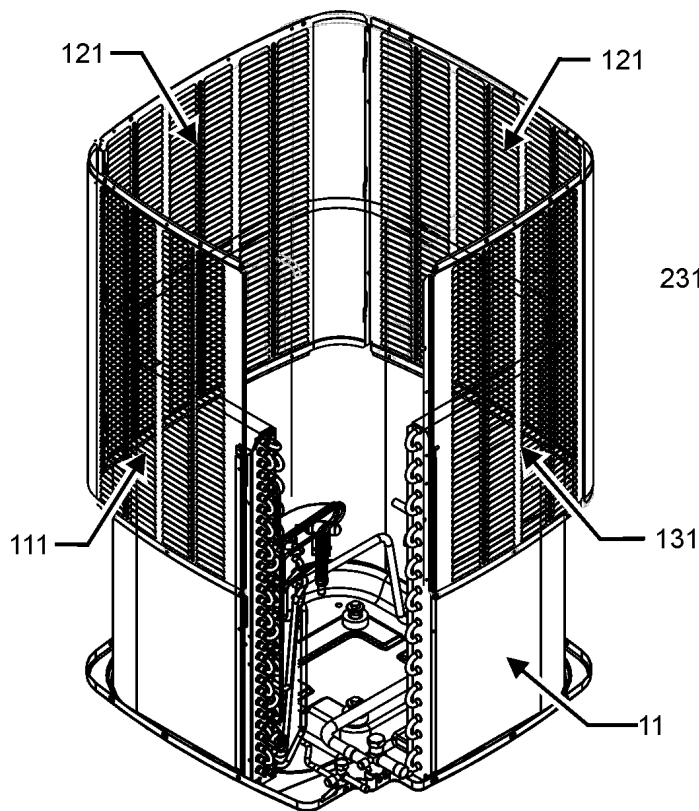

LOUVER PANEL ASSEMBLY
STYLE 1

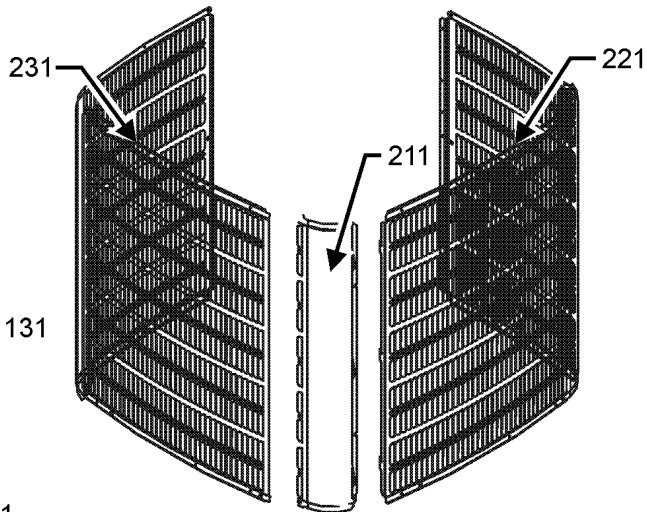

LOUVER PANEL ASSEMBLY
STYLE 2

Compressor and Tubing Assembly

Ref. Part No: No:	Description:	Ref. Part No: No:	Description:																			
Image 1:		Image 1:																				
11	0201R00434	NS	B1789878 FLOW CHECK PISTON KIT (M12, M13, M14, M15)																			
11	0201R00296	NS	B1789886 FLOW CHECK PISTON KIT (M16)																			
11	0201R00236	NS	B1789888 FLOW CHECK PISTON KIT (M17, M18, M19)																			
11	0201R00311	Expanded Model Nomenclature																				
11	0201R00315	<table border="1"> <tr><td>M1 - GSX160181FE</td></tr> <tr><td>M2 - GSX160181FF</td></tr> <tr><td>M3 - GSX160241FF</td></tr> <tr><td>M4 - GSX160241FG</td></tr> <tr><td>M5 - GSX160301FF</td></tr> <tr><td>M6 - GSX160301FG</td></tr> <tr><td>M7 - GSX160361FE</td></tr> <tr><td>M8 - GSX160361FF</td></tr> <tr><td>M9 - GSX160421FE</td></tr> <tr><td>M10 - GSX160421FF</td></tr> <tr><td>M11 - GSX160421FG</td></tr> <tr><td>M12 - GSX160481FE</td></tr> <tr><td>M13 - GSX160481FF</td></tr> <tr><td>M14 - GSX160481FG</td></tr> <tr><td>M15 - GSX160481FH</td></tr> <tr><td>M16 - GSX160601FF</td></tr> <tr><td>M17 - GSX160611FE</td></tr> <tr><td>M18 - GSX160611FF</td></tr> <tr><td>M19 - GSX160611FG</td></tr> </table>		M1 - GSX160181FE	M2 - GSX160181FF	M3 - GSX160241FF	M4 - GSX160241FG	M5 - GSX160301FF	M6 - GSX160301FG	M7 - GSX160361FE	M8 - GSX160361FF	M9 - GSX160421FE	M10 - GSX160421FF	M11 - GSX160421FG	M12 - GSX160481FE	M13 - GSX160481FF	M14 - GSX160481FG	M15 - GSX160481FH	M16 - GSX160601FF	M17 - GSX160611FE	M18 - GSX160611FF	M19 - GSX160611FG
M1 - GSX160181FE																						
M2 - GSX160181FF																						
M3 - GSX160241FF																						
M4 - GSX160241FG																						
M5 - GSX160301FF																						
M6 - GSX160301FG																						
M7 - GSX160361FE																						
M8 - GSX160361FF																						
M9 - GSX160421FE																						
M10 - GSX160421FF																						
M11 - GSX160421FG																						
M12 - GSX160481FE																						
M13 - GSX160481FF																						
M14 - GSX160481FG																						
M15 - GSX160481FH																						
M16 - GSX160601FF																						
M17 - GSX160611FE																						
M18 - GSX160611FF																						
M19 - GSX160611FG																						
11	0201R00433																					
31	0151R00081																					
31	0151R00079																					
31	0151R00080																					
41	0151R00167																					
51	ZP14K5EPFV130																					
51	ZP20K5EPFV130																					
51	ZP24K5EPFV130																					
51	ZP29K5EPFV130																					
51	ZP34K5EPFV130																					
51	ZP36K5EPFV130																					
51	ZP44K5EPFV130																					
51	ZP49K5EPFV130																					
71	M0221641																					
81	B1339533																					
91	0162R00009																					
111	0121R00228PDG																					
111	0121R00043PDG																					
111	0121R00229PDG																					
121	0121R00232PDG																					
121	0121R00231PDG																					
121	0121R00047PDG																					
131	0121R00234PDG																					
131	0121R00235PDG																					
131	0121R00051PDG																					
141	0121R00006PDG																					
141	0121R00007PDG																					
151	0159R00001P																					
151	0159R00002P																					
161	0163R00003																					
211	0121R00350PDG																					
211	0121R00352PDG																					
211	0121R00354PDG																					
221	0121R00342PDGRS																					
221	0121R00344PDGRS																					
221	0121R00346PDGRS																					
231	0121R00342PDGLS																					
231	0121R00344PDGLS																					
231	0121R00346PDGLS																					
NS	B1789849																					
NS	B1789857																					
NS	B1789865																					
NS	B1789872																					
NS	B1789874																					