

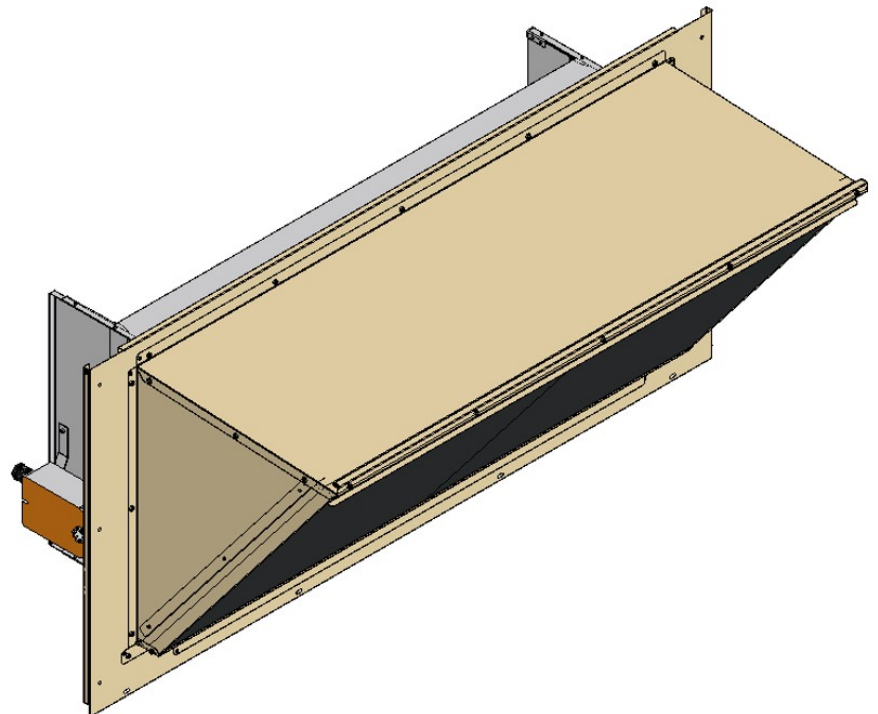

## APPLICATION

Most building codes require a certain amount of fresh air to overcome the effects of CO<sub>2</sub> during times when the space is occupied. Use of fresh air dampers on HVAC equipment is an inexpensive way to allow fresh air into the building. McDaniel Metals offers a motorized fresh air damper to fit Daikin light commercial packaged equipment. The motorized fresh air damper includes a small two position actuator that opens the damper when the indoor blower is running and closes the damper when the blower turns off.

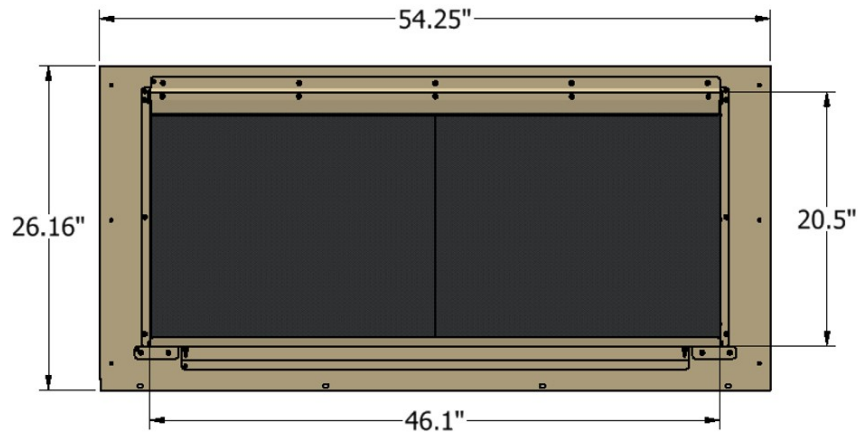
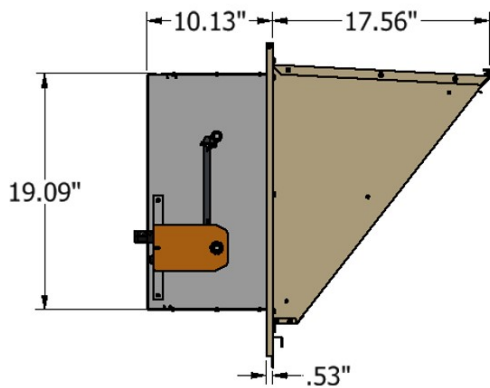

## FEATURES

- Up to 100% Fresh Air
- Slide damper for easy adjustment
- 24VAC damper motor w/spring return
- Hood Painted to Match Daikin Unit
- Plug-n-Play
- Fuels 7-1/2 to 12-1/2 Ton Daikin DB\*/DRG RTUs