

Project Name:	Approval:
Location:	Date:
Engineer:	Construction:
Submitted to:	Unit #:
Submitted by:	Drawing #:
Reference:	

MODEL COMPATIBILITY:

Compatible with VRV and VRV Life™ indoor unit models: FXAQ, FXDQ, FXEQ, FXFQ, FXHQ, FXLQ, FXMQ, FXMQ_MF, FXNQ, FXSQ, FXTQ, FXUQ, FXZQ, CXTQ, VAM, FXAA¹, FXFA¹, FXMA¹, FXSA¹, FXTA¹, FXZA¹

Compatible with SkyAir indoor unit models: FAQ, FBQ, FCQ, FHQ, FTQ, FAA¹, FBA¹, FCA¹, FTA¹

Compatible with Single Zone/Multi Zone/SkyAir system indoor unit models:

- FDMQ, FFQ_Q, FFQ_W, FDMA
- FFQ_LVJU with the use of the Interface Adaptor DTA112BA51
- CDXS, CTX, CTXG, CTXS, CTXV, FDXS, FTK, FTKF, FTKN, FTX, FTXB_BX, FTXF_BV, FTXG, FTXM, FTXN, FTXQ, FTXR, FTXS, FTXV, FVXS, FVXV, FTXC_AX, FTXF_AX, FTKF_AX with DIII-Net Adapter KRP928BB2S
- Exclusions: FTK_AX, FTKB_AX, FTX_AX, FTXB_AX do not support centralized controls

Note 1: R32 VRV units use a D4-net protocol. A D3/D4 adapter, BRD72A-L (sold separately), is required.

SPECIFICATIONS:

Model	DMS502B71
Description	BACnet Interface
Maximum Indoor Units	128 groups/256 indoor units (256 groups/512 indoor units with DAM411B51)
Maximum Outdoor Units	20 (40 with DAM411B51)
DIII-Net Communication Wire	18AWG-2, No polarity Stranded, Non-shielded
BACnet IP Communication Wiring	10Base-T/100Base-TX
Communication Protocol	Daikin Proprietary DIII-Net protocol / BACnet IP
IP Setting Range	Class C network
Power	24VAC (field supplied) (40VA maximum)
Comfort Setpoint Range	60 to 90 °F (16 to 32 °C)
Setpoint	Single Setpoint
Temperature Units	Degrees Fahrenheit or Celsius
Operating Temp Range	14 to 122°F (-10 to 50°C)
Operating Humidity Range	90% or less (RH) (w/o condensation)
Dimensions (WxHxD)	10.81 x 10.34 x 2.69 inch (274.57 x 262.13 x 68.33 mm)
Weight (Mass)	6.2 lbs. (2.8 kg)
Certification	FCC Part 15 Subpart B Class A

PRODUCT IMAGE:



Notes:
Image shows BACnet Interface (DMS502B71) with Optional DIII Board (DAM411B51) inserted

Project Name:	Approval:
Location:	Date:
Engineer:	Construction:
Submitted to:	Unit #:
Submitted by:	Drawing #:
Reference:	

OPTIONS:

- Option DIII Board DAM411B51 can be applied to add two additional DIII-Net ports to the BACnet Interface

FEATURES:

- Integrate Daikin VRV, SkyAir, Single and Multi-zone systems with third party building automation systems supporting the BACnet protocol
- BACnet Application Specific Controller (B-ASC) device profile compatible with BACnet (ANSI / ASHRAE-135)
- BACnet IP Data Link Layer (Annex J)
- Supports COV – Change of Value, Property Array Index and Segmented requests
- IPv4 and Foreign Device registration for use with BACnet Broadcast Management Devices (BBMD)
- BTL listed (operating system version 6.2 and later)
- Diagnostic LEDs
- 2 Alarm Output contacts DO-1 and DO-2
- 4 Digital Inputs for Forced Off function
- The following programing is required from BMS:
 - Auto-changeover
 - Setpoint Range Limitation
 - Setback
 - Scheduling
 - Dual Setpoints

SYSTEM DIAGRAM:

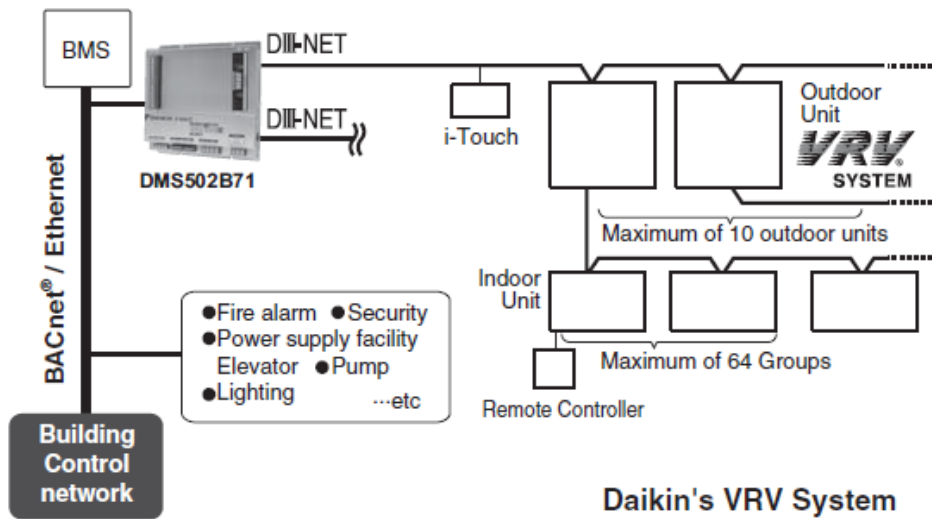



Submittal Data Sheet

DMS502B71 – Interface for use in BACnet

Project Name:	Approval:
Location:	Date:
Engineer:	Construction:
Submitted to:	Unit #:
Submitted by:	Drawing #:
Reference:	

INDOOR UNIT MONITORING AND CONTROL POINTS:

↙ Check the appropriate box indicating the required integrated points for this project.

Function		Description
Operation, configuration, and monitoring	On/Off (Note2)	Start / stops the indoor unit and monitors the latest status
	Operation Mode (Note 2)	Sets the cool / Heat / Fan/ Dry mode for the indoor unit and monitors the latest mode
	Setpoint setting (Note 2)	Sets the setpoint of the indoor unit and monitors the latest setpoint.
	Filter sign and reset	Monitors filter run time, provides service alert, and allows a manual reset of the status as required.
	Remote controller permit/prohibit	Permits or prohibits the remote controller so that it can or cannot be used to control the indoor unit's On/Off/Operation mode/Setpoint
	Lower Centralized Controller operation enable/disable	Enables or disables operation of a Centralized Controller connected to the DIII network.
	Fan Speed setting (Note 2)	Sets the fan speed and monitors the latest setting.
	Airflow direction setting (Note 2)	Sets the airflow direction and monitors the latest setting.
	Forced system stop	The forced system stop command will force the indoor units to stop running based upon a received emergency alarm input. Remote controllers will be locked out from restarting indoor units during a forced system stop event.
	Forced Thermo-off	In response to the forced thermo-off command, the indoor unit stops actively cooling or heating.
	Energy saving	Offsets the internal setpoint +3.6°F (2°C) in cooling, and -3.6°F (-2°C) in heating in an indoor unit. The actual setpoint is not changed.
	Ventilation mode setting (Note 2)	Sets the ventilation mode and monitors the latest mode.
	Ventilation amount setting (Note 2)	Sets the ventilation amount and monitors the latest amount.
Monitoring	On/Off status	Monitors the On/Off status of the indoor unit.
	Alarm	Monitors whether or not the indoor unit is operating normally, and issues an alarm if the indoor unit has a malfunction.
	Malfunction code	Displays a malfunction code specified by Daikin if an indoor unit in the system has a malfunction.
	Operation mode	Monitors if the indoor unit is in Cool, Heat, Fan, or Dry mode.
	Room temperature (Note 1)	Monitors the room temperature.
	Filter sign	Monitors filter run time and provides service alert.
	Thermo-on status	Monitors whether or not the indoor unit is in actively cooling or heating.
	Compressor status	Monitors if the compressor of the outdoor unit connected to the indoor unit is properly operating.
	Indoor fan status	Monitors if the indoor unit's fan is properly operating.
	Heater status	Monitors if the indoor unit's heater is properly operating.
	Ventilation mode status	Monitors the ventilation mode status of the Energy Recover Ventilator
	Ventilation amount status	Monitors the ventilation amount status of the Energy Recovery Ventilator

1. Room temperature data (BACnet object name RoomTemp_XXX) by default is reported from the Daikin indoor units return air thermistor. This applies to all VRV indoor unit styles and capacities. During periods when the indoor unit is turned off or during certain operating modes that cycle the fan off including defrost operation, hot-start and system pressure equalization, the reported temperature may not accurately reflect the actual space temperature. For applications where this temperature value will be primary to system control including mode and temperature setpoint management, it is recommended that the Daikin remote temperature sensor (Part No. KRCS01-1B or 4B depending on model) is specified for each indoor unit and installed within the occupied space or unit be configured to be controlled from temperature sensor in BRC1E73 Navigation Controller if the unit is capable.
2. In the indoor unit, the setpoints, start/stop status, mode, airflow direction, and fan speed are written to the non-volatile memory each time they are changed so the settings are not lost in the event of a power failure. The number of times this non-volatile memory can be written is

DAIKIN COMFORT TECHNOLOGIES NORTH AMERICA, INC.

19001 Kermier Road, Waller, TX, 77484

www.daikincity.com | www.daikincomfort.com

Rev.2604

(Daikin's products are subject to continuous improvements. Daikin reserves the right to modify product design, specifications, and information in this data sheet without notice and without incurring any obligations)

Project Name:	Approval:
Location:	Date:
Engineer:	Construction:
Submitted to:	Unit #:
Submitted by:	Drawing #:
Reference:	

limited, and writing beyond that limit may cause failure to the indoor unit EEPROM. This will not cause the indoor unit to stop functioning; however, the volatile memory will not retain the last settings received. Consequently, when the setpoints, start/stop status, mode, airflow direction, and fan speed are frequently changed by automatic control from the BMS, the number of times each setting for each indoor unit is limited to 70,000 – 80,000 times per year (dependent on the indoor unit manufacturing date). If the same value is repeatedly sent, it will not be added to the total “write to” count.

3. BACnet® is a registered trademark of ASHRAE.

COMPATIBILITY:

Function	VRV indoor unit	SkyAir indoor unit (except FTXS)	VAM	Outdoor air processing unit	Mini-Split & SkyAir FTXS indoor units (KRP928 adapter required)	FFQ indoor unit for Multi-split & Super Multi Plus (DTA112BA51 adapter required)
On/Off operation and monitoring	✓	✓	✓	✓	✓	✓
Indoor unit malfunction notification	✓	✓	✓	✓	✓	✓
Room temperature monitoring	✓	✓	N/A	✓ (return air)	✓	✓
Setpoint setting and monitoring	✓	✓	N/A	N/A	✓	✓
Operation mode setting and monitoring	✓	✓	N/A	✓	✓	✓
Remote-control permit/prohibit setting and monitoring	✓	✓	✓	✓	✓	✓
Filter sign monitoring and reset	✓	✓	✓	✓	N/A	✓
Thermo-on status monitoring	✓	✓	N/A	✓	N/A	✓
Compressor operation status monitoring	✓	✓	N/A	✓	N/A	✓
Indoor fan status monitoring	✓	✓	✓	✓	N/A	✓
Heater status monitoring	✓	✓	N/A	✓	N/A	✓
Airflow direction setting and monitoring	✓	✓	N/A	N/A	N/A	✓
Fan speed settings and monitoring	✓	✓	✓ (Monitoring)	N/A	N/A	✓
Forced thermo-off setting and monitoring	✓	✓	N/A	✓	N/A	✓
Energy saving (setpoint offset)	✓	✓	N/A	✓	N/A	N/A
Ventilation Mode	N/A	N/A	✓	N/A	N/A	N/A
Ventilation Amount	N/A	N/A	✓	N/A	N/A	N/A

Project Name:	Approval:
Location:	Date:
Engineer:	Construction:
Submitted to:	Unit #:
Submitted by:	Drawing #:
Reference:	

DIMENSIONS:

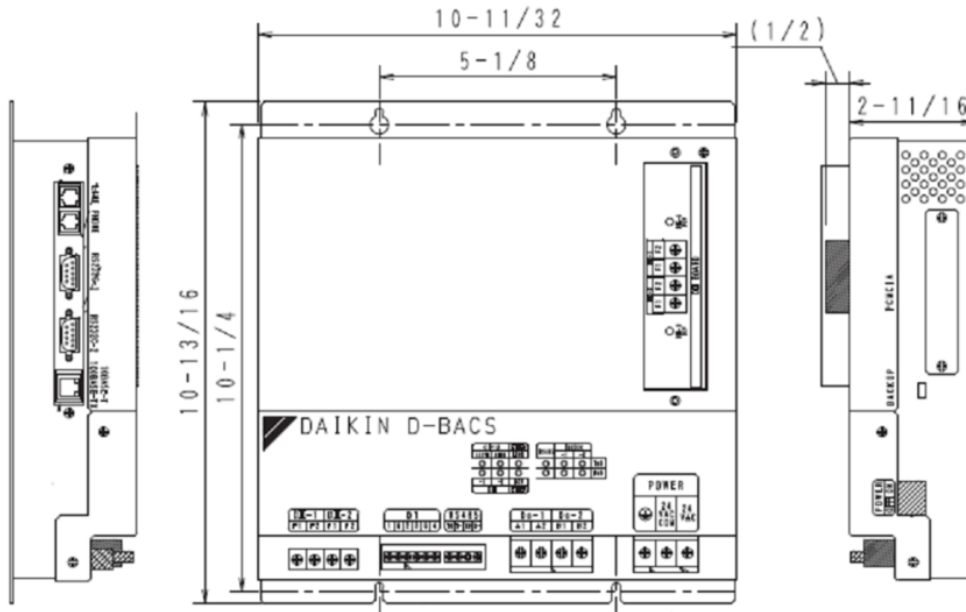

DOCUMENTATION:

Documentation available on www.daikincity.com and/or www.daikincomfort.com:

- BACnet Design Guide
- Installation Manual
- Submittal
- Guide Specifications