

Project Name: _____

Location: _____

Engineer: _____

Submitted to: _____

Submitted by: _____

Reference: _____

Approval: _____

Date: _____

Construction: _____

Unit #: _____

Drawing #: _____

Model	DZK030E5
Description	Zoning Box
Compatible Indoor Units	FBQ18 - 30PVJU; FXMQ15 - 24PAVJU
Damper Control	Flow Control System by Airzone
Damper Size	6"
Number of Dampers	5
Insulation Value	R4
Weight (Mass)	20.24lb (9.2 kg)
Size	W: 43.58" (1107 mm) H: 10.43" (265 mm) D: 10.43" (265 mm)

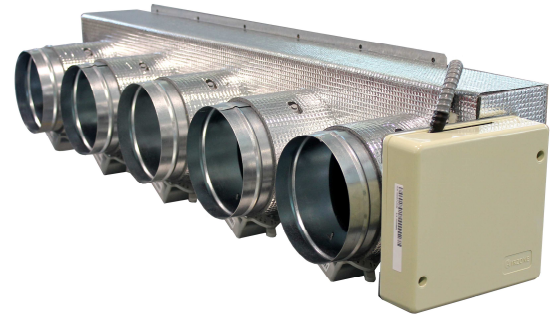
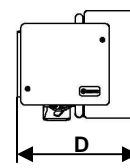
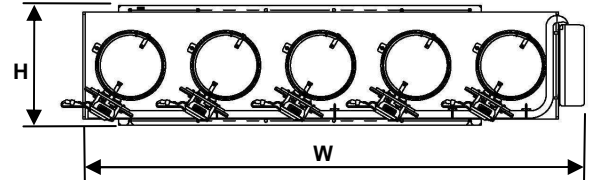

Features / Benefits:

- Allows multiple individually controlled zones with one Daikin Indoor Unit fan coil.
- Individual design for each Daikin unit model.
- Reduced size and weight.
- Fast and simple assembly.
- Manual setting of maximum and minimum flow rate for each damper.

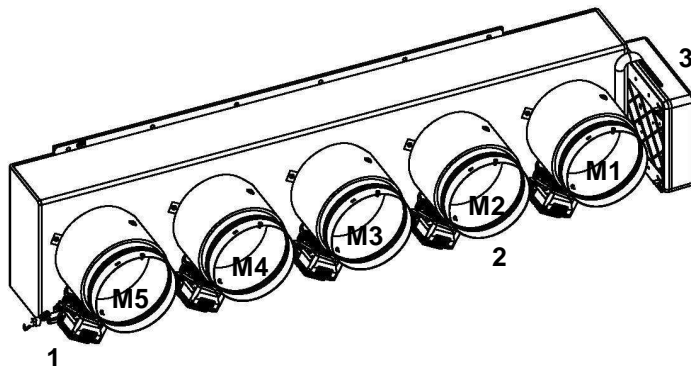

Ref	Function
1	Actuator
2	Damper
3	Main Control Board
M1 ... M5	Dampers number from 1 to 5

Note: Dampers are numbered starting with number 1 next to the Zoning box Control Board.



Project Name: _____

Location: _____

Engineer: _____

Submitted to: _____

Submitted by: _____

Reference: _____

Approval: _____

Date: _____

Construction: _____

Unit #: _____

Drawing #: _____

Dimensional Drawing: (Units inch)

