

SPE180300X

DOWNFLOW POWER EXHAUST  
FITS DAIKIN DB\*180300,  
SANDSTONE BEIGE

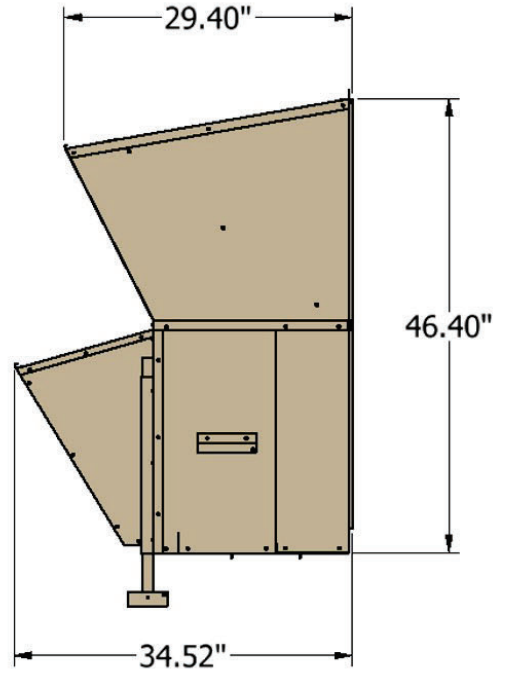
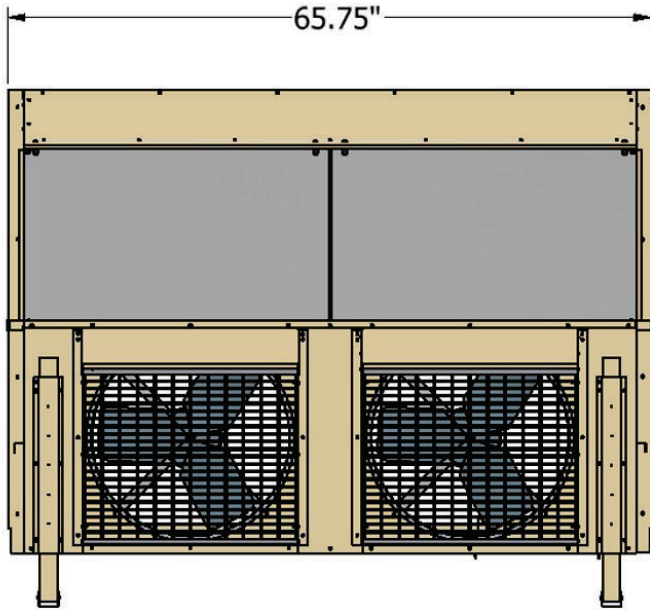

ITEM NO.	DESCRIPTION
SPE1803002	PROP. POWER EXHAUST, 208-230VAC
SPE1803004	PROP. POWER EXHAUST, 460VAC
SPE1803007	PROP. POWER EXHAUST, 575VAC

**FEATURES**

- Propeller type fan
- Multiple single-phase voltages
- Honeywell Jade & DDC Controller compatible
- Up to 100% relief @ 20 tons
- Painted to Match Daikin Unit
- Plug-n-Play
- Replaces Outside Air/Barometric Relief Hood
- 14-24" Curb Adjustable

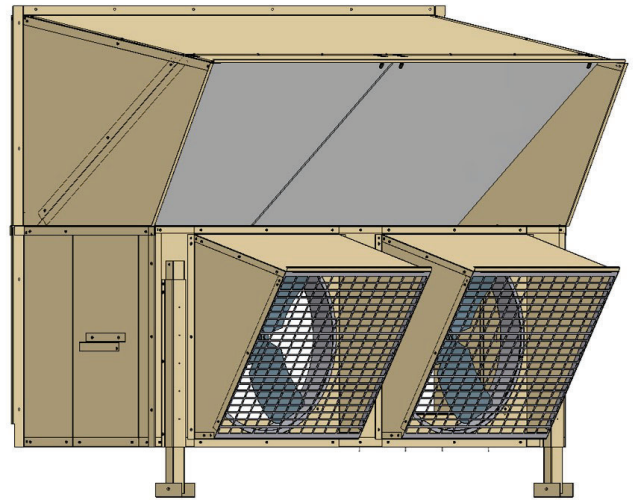

**Compatible McDaniel Metals Economizers**

ITEM NO.	DESCRIPTION
SDNECNJ180300BINT	DOWNFLOW ECONOMIZER, JADE, OUTDOOR ENTHALPY SENSOR, LOW-LEAK
SDNECNDB180300BINT	DOWNFLOW ECONOMIZER, JADE, OUTDOOR DRY BULB SENSOR, LOW-LEAK
SDNECNJ180300B1AINT	DOWNFLOW ECONOMIZER, JADE, OUTDOOR ENTHALPY SENSOR, ULTRA LOW-LEAK
SDNECNDB180300B1AINT	DOWNFLOW ECONOMIZER, JADE, OUTDOOR DRY BULB SENSOR, ULTRA LOW-LEAK
SDNECDDC180300BINT	DOWNFLOW ECONOMIZER, DDC CONTROL, LOW-LEAK
SDNECDDC180300B1AINT	DOWNFLOW ECONOMIZER, DDC CONTROL, ULTRA LOW-LEAK