

Service and Troubleshooting

SINGLE PACKAGE VERTICAL HEAT PUMP SYSTEM R-410A REFRIGERANT

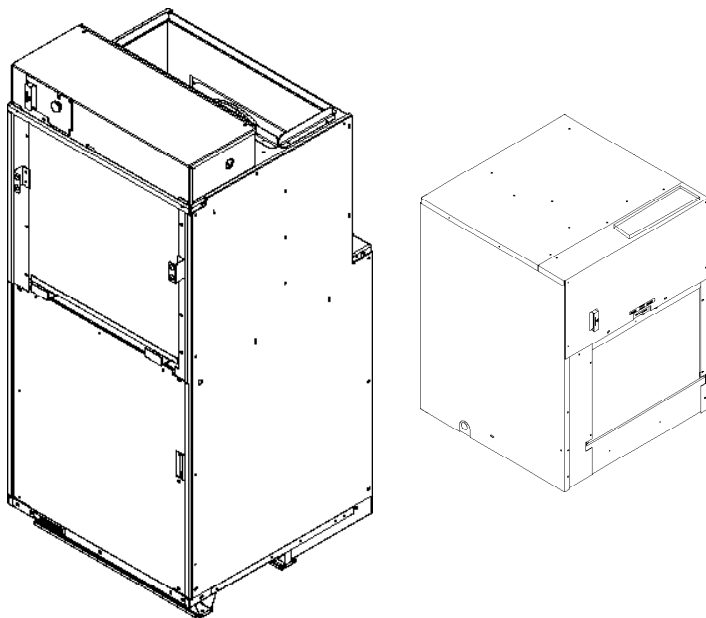

This manual is to be used by qualified, professionally trained HVAC technicians only. **Daikin** does not assume any responsibility for property damage or personal injury due to improper service procedures or services performed by an unqualified person.

Pride and workmanship go into every product to provide our customers with quality products. It is possible, however, that during its lifetime a product may require service. Products should be serviced only by a qualified service technician who is familiar with the safety procedures required in the repair and who is equipped with the proper tools, parts, testing instruments and the appropriate service manual. **REVIEW ALL SERVICE INFORMATION IN THE APPROPRIATE SERVICE MANUAL BEFORE BEGINNING REPAIRS.**



WARNING

ONLY PERSONNEL THAT HAVE BEEN TRAINED TO INSTALL, ADJUST, SERVICE, MAINTENANCE OR REPAIR (HEREINAFTER, "SERVICE") THE EQUIPMENT SPECIFIED IN THIS MANUAL SHOULD SERVICE THE EQUIPMENT.

THIS EQUIPMENT IS NOT INTENDED FOR USE BY PERSONS (INCLUDING CHILDREN) WITH REDUCED PHYSICAL, SENSORY OR MENTAL CAPACITIES, OR LACK OF EXPERIENCE AND KNOWLEDGE, UNLESS THEY HAVE BEEN GIVEN SUPERVISION OR INSTRUCTION CONCERNING USE OF THE APPLIANCE BY A PERSON RESPONSIBLE FOR THEIR SAFETY.

CHILDREN SHOULD BE SUPERVISED TO ENSURE THAT THEY DO NOT PLAY WITH THE EQUIPMENT.

THE MANUFACTURER WILL NOT BE RESPONSIBLE FOR ANY INJURY OR PROPERTY DAMAGE ARISING FROM IMPROPER SUPERVISION, SERVICE OR SERVICE PROCEDURES. IF YOU SERVICE THIS UNIT, YOU ASSUME RESPONSIBILITY FOR ANY INJURY OR PROPERTY DAMAGE WHICH MAY RESULT. IN ADDITION, IN JURISDICTIONS THAT REQUIRE ONE OR MORE LICENSES TO SERVICE THE EQUIPMENT SPECIFIED IN THIS MANUAL, ONLY LICENSED PERSONNEL SHOULD SERVICE THE EQUIPMENT. IMPROPER SUPERVISION, INSTALLATION, ADJUSTMENT, SERVICING, MAINTENANCE OR REPAIR OF THE EQUIPMENT SPECIFIED IN THIS MANUAL, OR ATTEMPTING TO INSTALL, ADJUST, SERVICE OR REPAIR THE EQUIPMENT SPECIFIED IN THIS MANUAL WITHOUT PROPER SUPERVISION OR TRAINING MAY RESULT IN PRODUCT DAMAGE, PROPERTY DAMAGE, PERSONAL INJURY OR DEATH.



WARNING

DO NOT BYPASS SAFETY DEVICES.

RS4200008
October 2024

©2019-2024 Daikin Comfort Technologies Manufacturing, L.P.



Amana® Brand is a registered trademark of Maytag Corporation or its related companies and is used under license. All rights reserved.

IMPORTANT INFORMATION

TABLE OF CONTENTS

IMPORTANT INFORMATION	2
PRODUCT IDENTIFICATION	4
SPECIFICATIONS	5
SYSTEM OPERATION	15
REMOVE AND INSTALL THE CHASSIS	22
EXTERNAL STATIC PRESSURE	23
TROUBLESHOOTING	26
COMPONENT IDENTIFICATION	27
R-410A REFRIGERANT SYSTEM REPAIR	48
WIRING DIAGRAMS	58

IMPORTANT NOTICES FOR CONSUMERS AND SERVICERS RECOGNIZE SAFETY SYMBOLS, WORDS AND LABELS

 WARNING	
HIGH VOLTAGE DISCONNECT ALL POWER BEFORE SERVICING OR INSTALLING THIS UNIT. MULTIPLE POWER SOURCES MAY BE PRESENT. FAILURE TO DO SO MAY CAUSE PROPERTY DAMAGE, PERSONAL INJURY OR DEATH.	

SAFE REFRIGERANT HANDLING

While these items will not cover every conceivable situation, they should serve as a useful guide.

 WARNING
REFRIGERATION SYSTEM UNDER HIGH PRESSURE! Do not puncture, heat, expose to flame or incinerate. Only certified refrigeration technicians should service this equipment. R410A systems operate at higher pressures than R22 equipment. Appropriate safe service and handling practices must be used. Only use gauge sets designed for use with R410A. Do not use standard R22 gauge sets.

OUTSIDE THE U.S., call 1-713-861-2500.
(Not a technical assistance line for dealers.) Your telephone company will bill you for the call.

IMPORTANT INFORMATION

ELECTRICAL HAZARDS

- Unplug and/or disconnect all electrical power to the unit before performing inspections, maintenance, or service.
- Make sure to follow proper lockout/tag out procedures.
- Always work in the company of a qualified assistant if possible.
- Capacitors, even when disconnected from the electrical power source, retain an electrical charge potential capable of causing electric shock or electrocution.
- Handle, discharge, and test capacitors according to safe, established, standards, and approved procedures.
- Extreme care, proper judgment, and safety procedures must be exercised if it becomes necessary to test or troubleshoot equipment with the power on to the unit.
- Do not spray water on the air conditioning unit while the power is on.
- Electrical component malfunction caused by water could result in electric shock or other electrically unsafe conditions when the power is restored and the unit is turned on, even after the exterior is dry.
- Use air conditioner on a single dedicated circuit within the specified amperage rating.
- Use on a properly grounded outlet only.
- Do not cut or modify the power supply cord or remove the ground prong of the plug.
- Never operate the unit on an extension cord.
- Follow all safety precautions and use proper and adequate protective safety aids such as: gloves, goggles, clothing, properly insulated tools, and testing equipment etc.
- Failure to follow proper safety procedures and/or these warnings can result in serious injury or death.

PERSONAL INJURY OR DEATH HAZARDS

REFRIGERATION SYSTEM REPAIR HAZARDS

- Use approved standard refrigerant recovering procedures and equipment to relieve high pressure before opening system for repair.
- Do not allow liquid refrigerant to contact skin. Direct contact with liquid refrigerant can result in minor to moderate injury.
- Be extremely careful when using an oxy-acetylene torch. Direct contact with the torch's flame or hot surfaces can cause serious burns.
- Make certain to protect personal and surrounding property with fire proof materials and have a fire extinguisher at hand while using a torch.
- Provide adequate ventilation to vent off toxic fumes, and work with a qualified assistant whenever possible.
- Always use a pressure regulator when using dry nitrogen to test the sealed refrigeration system for leaks, flushing etc.

MECHANICAL HAZARDS:

- Extreme care, proper judgment and all safety procedures must be followed when testing, troubleshooting, handling, or working around unit with moving and/or rotating parts.
- Be careful when, handling and working around exposed edges and corners of the sleeve, chassis, and other unit components especially the sharp fins of the indoor and outdoor coils.
- Use proper and adequate protective aids such as: gloves, clothing, safety glasses etc.
- Failure to follow proper safety procedures and/or these warnings can result in serious injury or death.

PROPERTY DAMAGE HAZARDS

FIRE DAMAGE HAZARDS

- Read the Installation/Operation Manual for the air conditioning unit prior to operating.
- Be extremely careful when using acetylene torch and protect surrounding property.
- Failure to follow these instructions can result in fire and minor to serious property damage.

WATER DAMAGE HAZARDS:

- Improper installation, maintenance or servicing of the air conditioner unit can result in water damage to personal items or property.
- Insure that the unit has a sufficient pitch to the outside to allow water to drain from the unit.
- Do not drill holes in the bottom of the drain pan or the underside of the unit.
- Failure to follow these instructions can result in damage to the unit and/or minor to serious property damage.

OPERATION OF EQUIPMENT IN DURING CONSTRUCTION

NOTE: OPERATION OF EQUIPMENT MUST BE AVOIDED DURING CONSTRUCTION PHASES WHICH WILL PRODUCE AIRBORNE DUST OR CONTAMINATES NEAR OR AROUND AIR INTAKE OPENINGS. FOR EXAMPLE:

- **WOOD OR METAL FRAMING;**
- **DRYWALLING OR SHEATHING,**
- **SPACKLING OR APPLYING JOINT COMPOUND.**
- **SANDING OR GRINDING.**
- **MOULDING OR TRIMWORK.**

PRODUCT IDENTIFICATION

NOMENCLATURE

Model Number	A	V	H	09	3	K	25	AXXX
A = Amana®Brand	V = Vertical PTAC		H = Heat Pump		Cooling Capacity			Standard Model
09 = 9,000 BTU/H		12 = 12,000 BTU/H		18 = 18,000 BTU/H		24 = 24,000 BTU/H		
Voltage		3 = 208/230V		4 = 265V		Electric Heater Size		
						25 = 2.5 kW		
						35 = 3.5 kW		
						50 = 5 kW		
						75 = 7.5 kW*		
						10 = 10kW*		
						*24,000 BTU Units only		
						K = DOE AHRI 210/240		
						2024 Ratings		

SPECIFICATIONS

ELECTRICAL SPECIFICATIONS

Models	Compressor Amps	Total Amps in Electric Heat	Electric Heat Watts	Electric Heat Amps	Compressor RLA/LRA	Blower Motor FLA/HP	Condenser Motor FLA/HP	MCA	Max Fuse
AVH093K25AXXX	6.8	11.5/10.4	2450/2000	10.7/9.6	4.2/21	0.8-1/8	1.8-1/4	14.4	15
AVH093K35AXXX	6.8	15.4/14.0	3350/2740	14.6/13.2	4.2/21	0.8-1/8	1.8-1/4	19.3	20
AVH093K50AXXX	6.8	22.5/20.5	5000/4090	21.7/19.7	4.2/21	0.8-1/8	1.8-1/4	28.2	30
AVH123K25AXXX	7.3	11.5/10.4	2450/2000	10.7/9.6	4.7/23	0.8-1/8	1.8-1/4	14.4	15
AVH123K35AXXX	7.3	15.4/14.0	3350/2740	14.6/13.2	4.7/23	0.8-1/8	1.8-1/4	19.3	20
AVH123K50AXXX	7.3	22.5/20.5	5000/4090	21.7/19.7	4.7/23	0.8-1/8	1.8-1/4	28.2	30
AVH183K25AXXX	9.1	11.5/10.4	2450/2000	10.7/9.6	6.8/30	0.8-1/5	1.5-1/4	14.4	15
AVH183K35AXXX	9.1	15.4/14.0	3350/2740	14.6/13.2	6.8/30	0.8-1/5	1.5-1/4	19.3	20
AVH183K50AXXX	9.1	22.5/20.5	5000/4090	21.7/19.7	6.8/30	0.8-1/5	1.5-1/4	28.2	30
AVH183K75AXXX	9.1	33.4/30.3	7500/6135	32.6/29.5	6.8/30	0.8-1/5	1.5-1/4	41.8	45
AVH243K25AXXX	10.7	11.5/10.4	2450/2000	10.7/9.6	8.2/44	0.8-1/5	1.7-1/4	16	20
AVH243K35AXXX	10.7	15.4/14.0	3350/2740	14.6/13.2	8.2/44	0.8-1/5	1.7-1/4	19.5	25
AVH243K50AXXX	10.7	22.5/20.5	5000/4090	21.7/19.7	8.2/44	0.8-1/5	1.7-1/4	29.6	30
AVH243K75AXXX	10.7	33.4/30.3	7500/6135	32.6/29.5	8.2/44	0.8-1/5	1.7-1/4	41.8	45
AVH243K10AXXX	10.7	44.3/40.1	1000/8180	43.5/39.3	8.2/44	0.8-1/5	1.7-1/4	55.4	60

SPECIFICATIONS

GENERAL SPECIFICATIONS

Model	AVH09K	AVH12K	AVH18K	AVH24K
Cooling Data				
Total Cap @ 95°F	9,000	11,000	17,600	21,800
Sensible Cap	6,650	8,100	12,500	15,400
SEER2	11.9	11.9	11.9	11.9
EER2	10.6	10.6	10.6	10.6
Heating Data				
Total Cap @ 47°F	8200	14,400	15,000	18,500
Cap @ 17°F	4,500	5,600	9,000	12,000
COP2	3.1	3.1	3.1	3.1
HSPF2	6.3	6.3	6.3	6.3
Heater Sizes	2.5/3.4/5.0	2.5/3.4/5.0	2.5/3.4/7.5	2.5/3.4/7.5/10.0
Voltage	208/230	208/230	208/230	208/230
Other Data				
Refrigerant	R410a			
Dimenstions	23x23x32		23x23x47	23x23x53
Ventilations CFM	Up to 70 CFM			
Airflow (0.3") CFM	300	350	550	600

ELECTRICAL REQUIREMENTS

ELECTRICAL REQUIREMENTS SEE UNIT NAMEPLATE FOR SPECIFIC ELECTRICAL REQUIRMENTS.	
FUSE / CIRCUIT BREAKER	USE ONLY TYPE AND SIZE FUSE OR HACR CURCUIT BREAKER INDICATED ON UNIT'S RATING GUIDE. PROPER OVER CURRENT PROTECTION TO THE UNITS IS THE RESPONSIBILITY OF THE OWNER.
GROUNDING	UNIT MUST BE GROUNDED FROM BRANCH CIRCUIT TO UNIT, OR THROUGH SEPARATE GROUND WIRE PROVIDED ON PERMANENTLY CONNECTED UNITS. ENSURE THAT BRANCH CIRCUIT OR GENERAL PURPOSE OUTLET IS GROUNDED.
WIRE SIZE	ALL WIRING MUST COMPLY WITH LOCAL AND NATIONAL CODES. USE MINIMUM AMPACITY RATING TO DETERMINE BRANCH CIRCUIT WRING SIZES.

WARNING

HIGH VOLTAGE
DISCONNECT ALL POWER BEFORE SERVICING OR INSTALLING THIS UNIT. MULTIPLE POWER SOURCES MAY BE PRESENT. FAILURE TO DO SO MAY CAUSE PROPERTY DAMAGE, PERSONAL INJURY OR DEATH. DO NOT SERVICE THIS UNIT WITHOUT FIRST SHUTTING OFF POWER TO THE UNIT FROM THE CIRCUIT BREAKER AND/OR REMOVING THE UNIT CORD SET PLUG FROM THE WALL OUTLET.



SPECIFICATIONS

AIRFLOW DATA (CONDENSER)

VTAC is designed to install through an exterior wall with a plenum (VPAWP1-8, VPAWP1-14) and an external louver. If the default plenum and louver combinations are not used, the selections and design must be evaluated by manufacturer to ensure the total pressure drop does not exceed the maximum allowable limits.

Condenser External Pressure			
Model	Design		Maximum
	CFM	ESP ("WP)	ESP ("WP)
AVH09K	650	0.03	0.12
AVH12K	650	0.03	0.12
AVH18K	950	0.03	0.12
AVH24K	950	0.03	0.12

SPECIFICATIONS

CHASSIS SPECIFICATIONS 9K, 12K

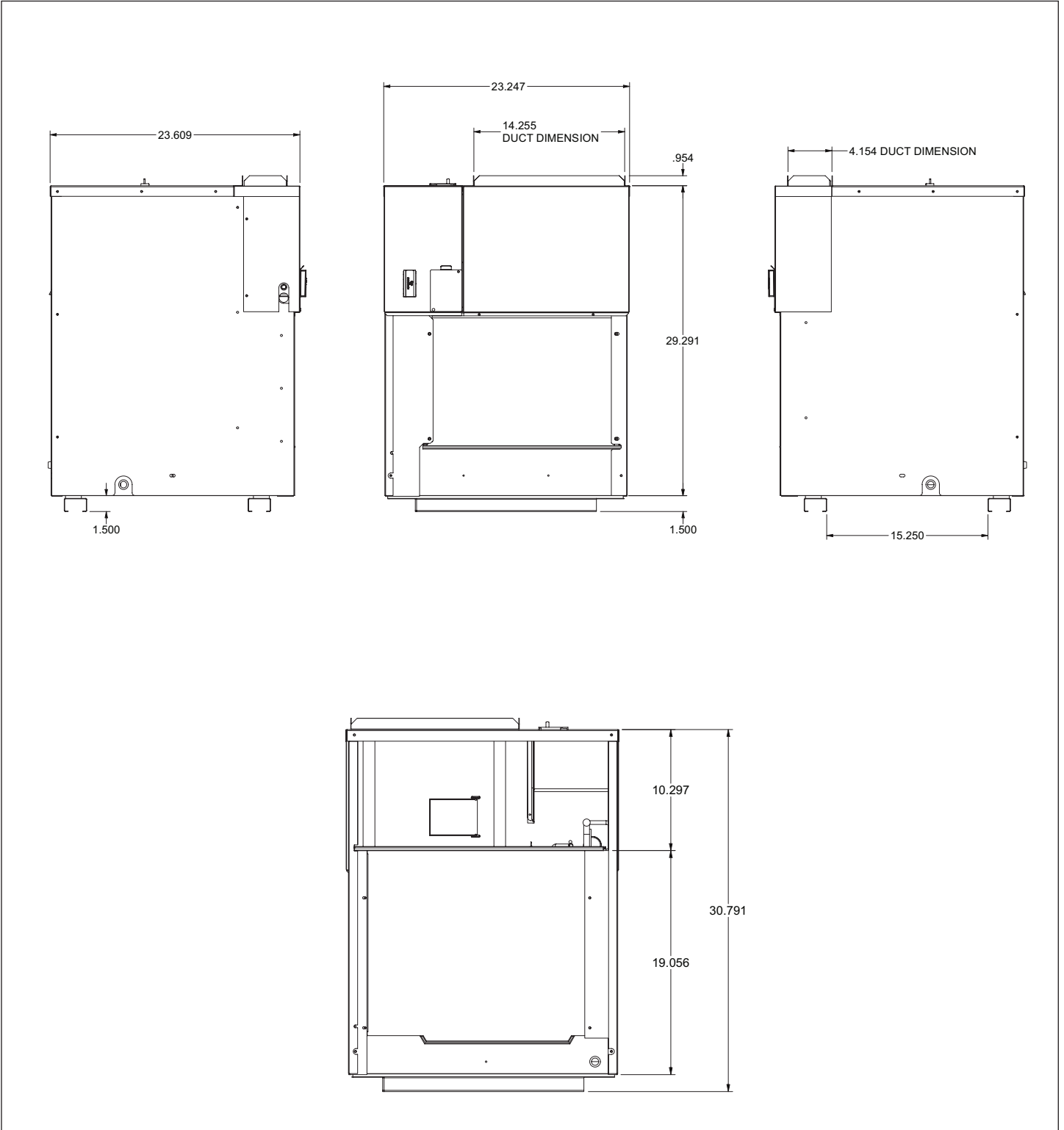

SPECIFICATIONS

18K DIMENSIONS

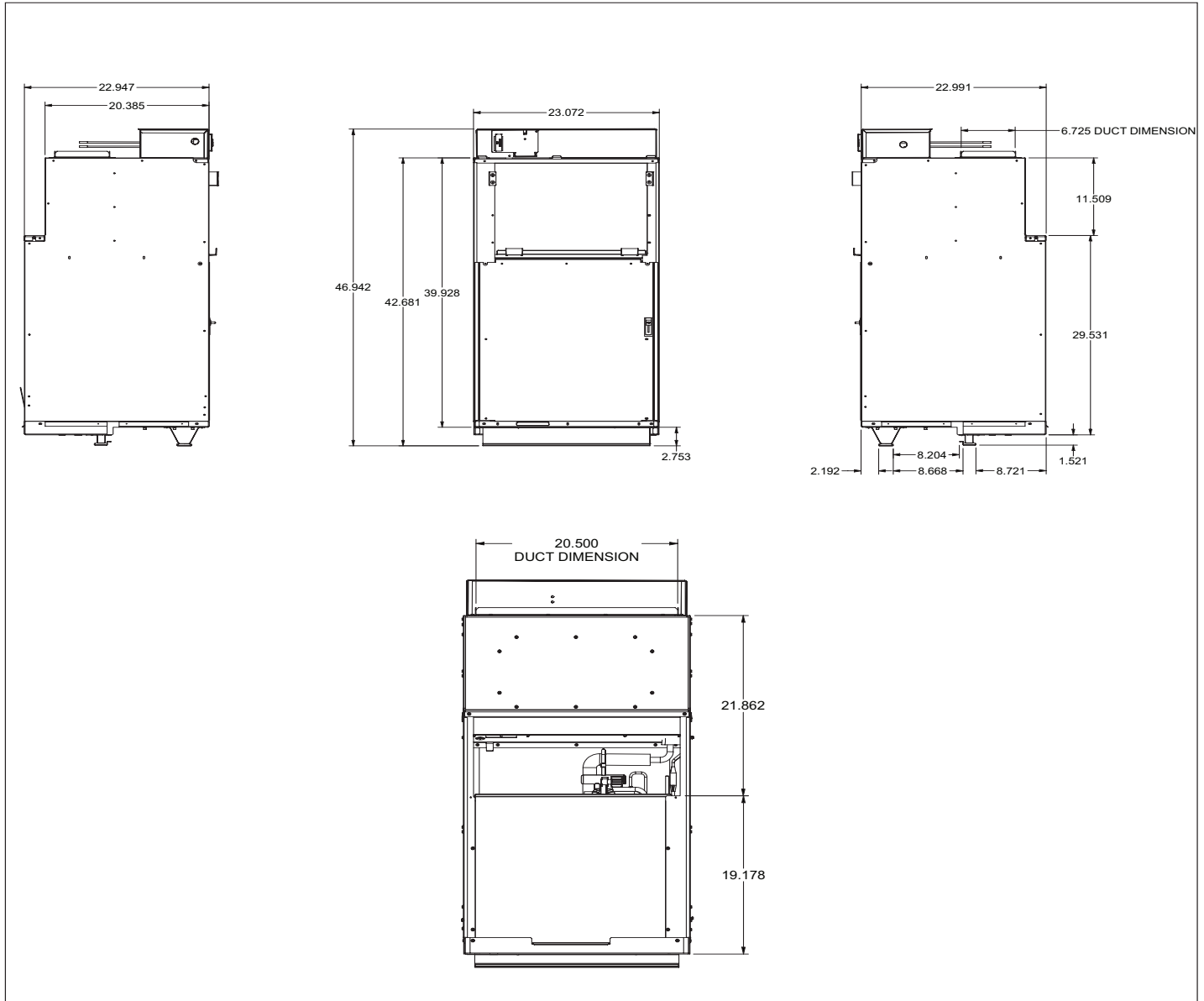

SPECIFICATIONS

24K DIMENSIONS

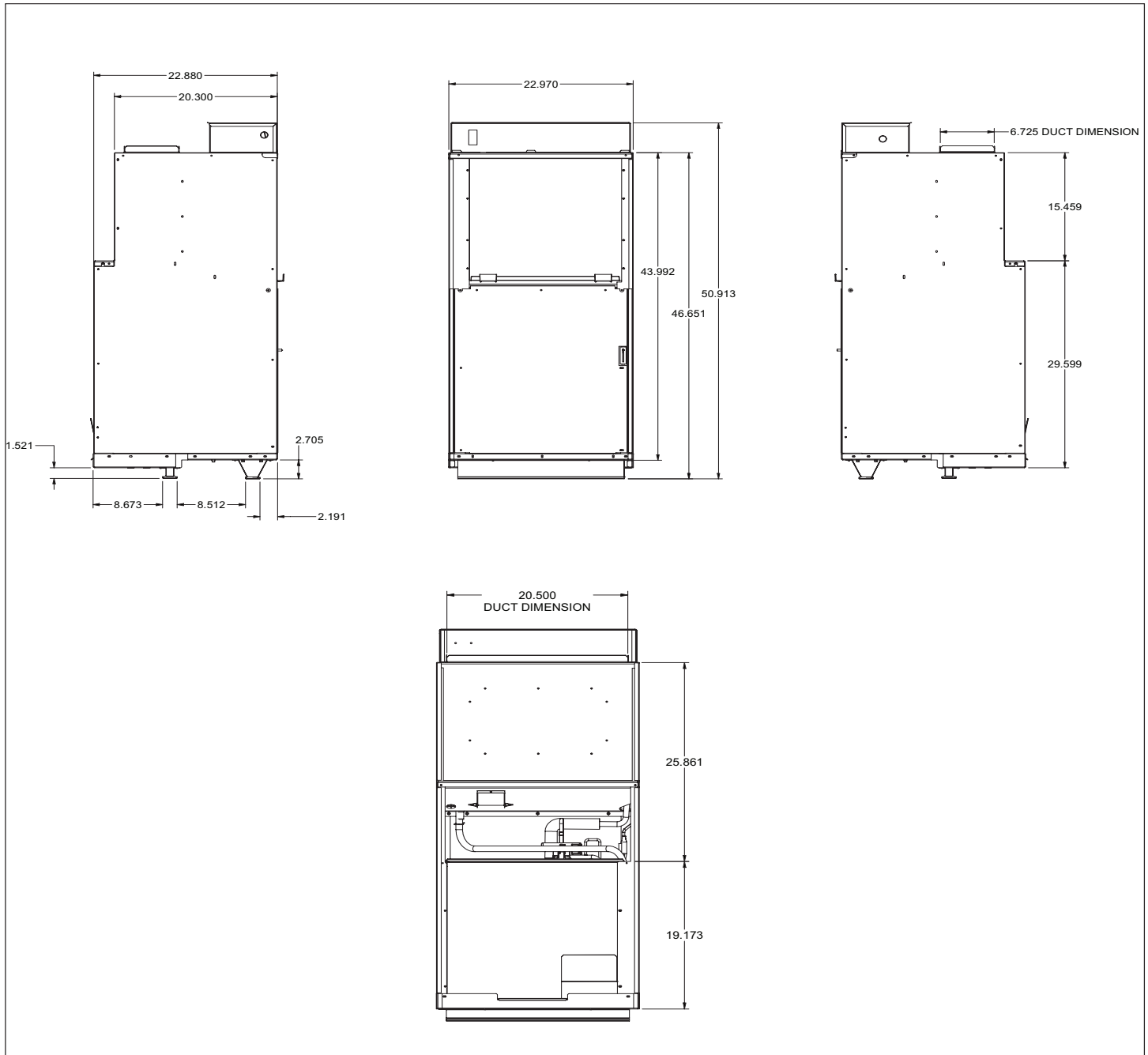

Building Exterior Unit Opening Requirements

VTAC units must be installed on an outside wall. Confined spaces and/or covered areas should be avoided. Units must be installed no closer than 12" apart when two units are side by side. If three or more units are to operate next to one another, maintain a minimum of 60" between units or pairs of units (Figure B & E). If more than two units are sharing a floor with adjacent, outset units, a minimum distance of 64" must be kept between units (Figure C). Also, a vertical clearance of 60" must be maintained (Figure A) between units. Units installed on the bottom floor must be mounted at least 6" off of the ground. If two units are facing each other, a minimum distance of 108" must be kept between units (Figure D).

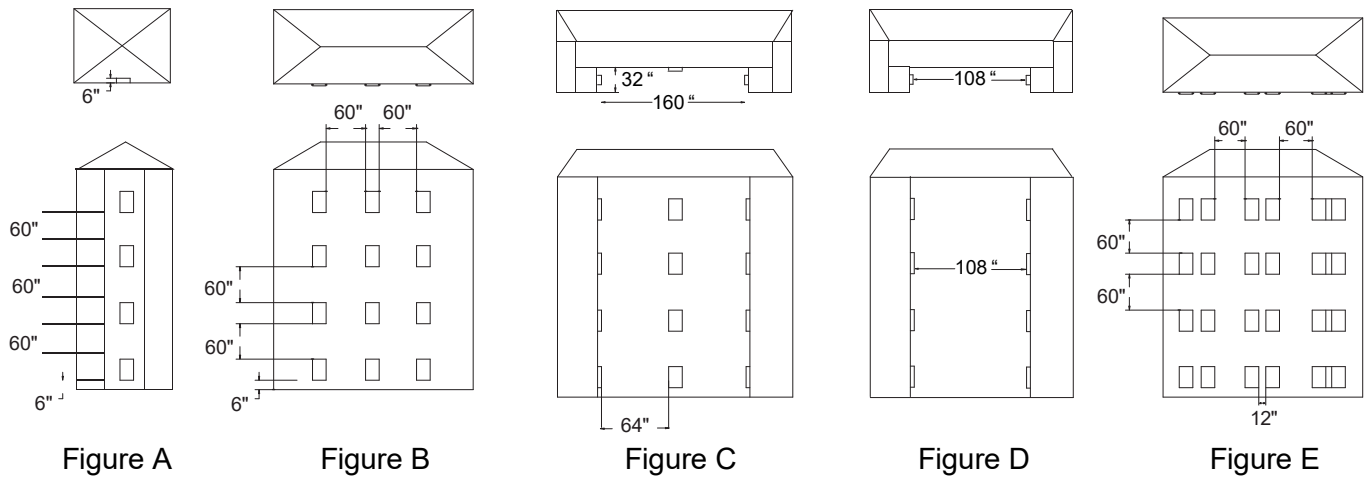

Grill Clearance Requirements

Where obstructions are present use the following guidelines for proper spacing from the VTAC exterior louvered grill. It is recommended that ALL obstructions are a minimum of 72" from the exhaust.

For minor obstruction(s) such as lamp poles or small shrubbery, a clearance of 24" from the outdoor louver must be maintained.

For major obstructions such as a solid fence, wall, or other heat rejecting devices like a condensing unit, a minimum distance of 72" must be kept.

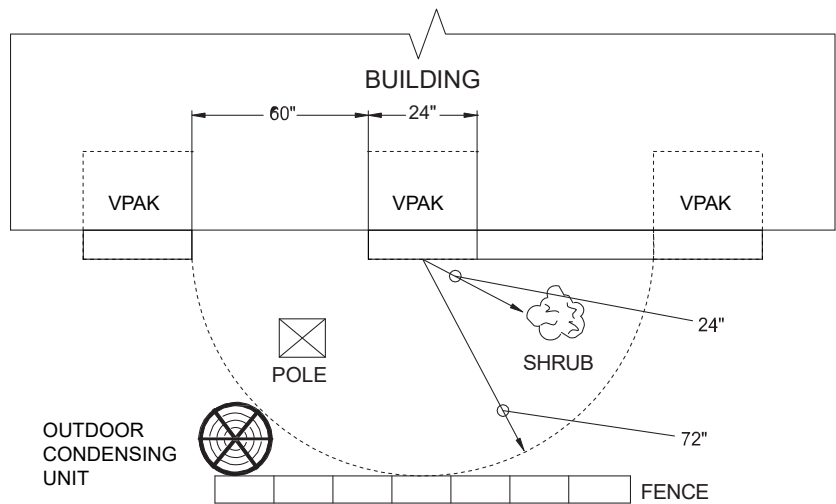

The the example pictured above is for reference only and does not represent all possible installations. Please contact Daikin for information regarding effects of other installation arrangements.

SPECIFICATIONS

CLOSET ORIENTATIONS & DIMENSIONS

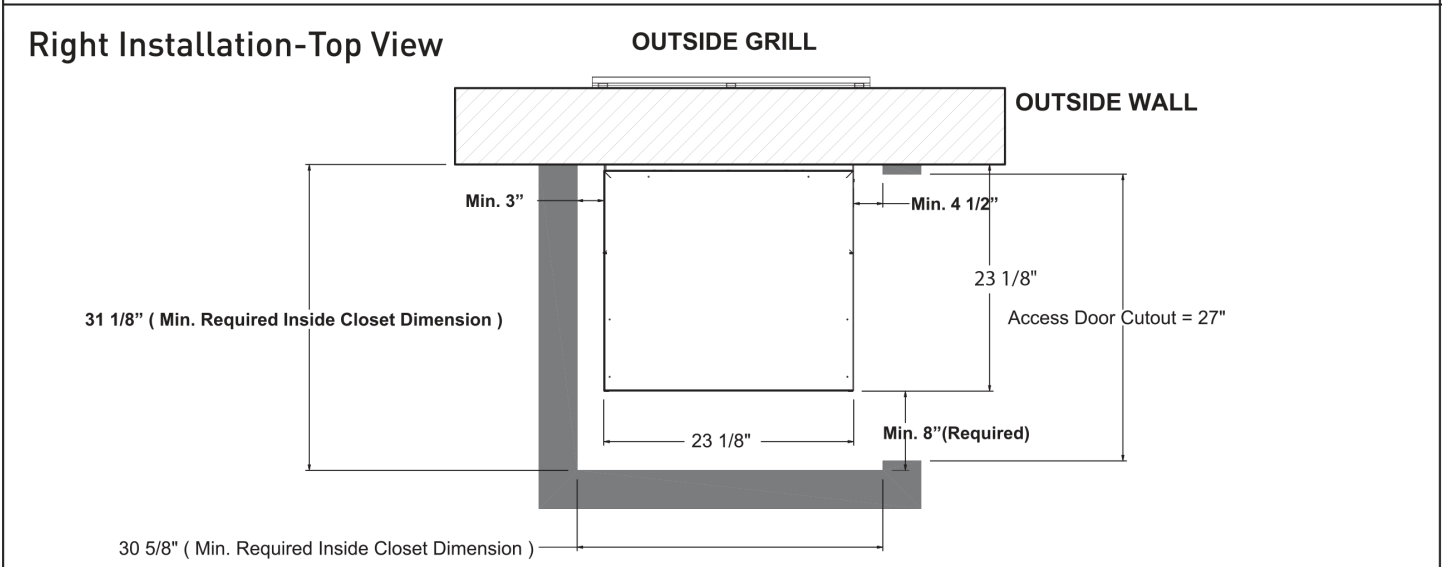
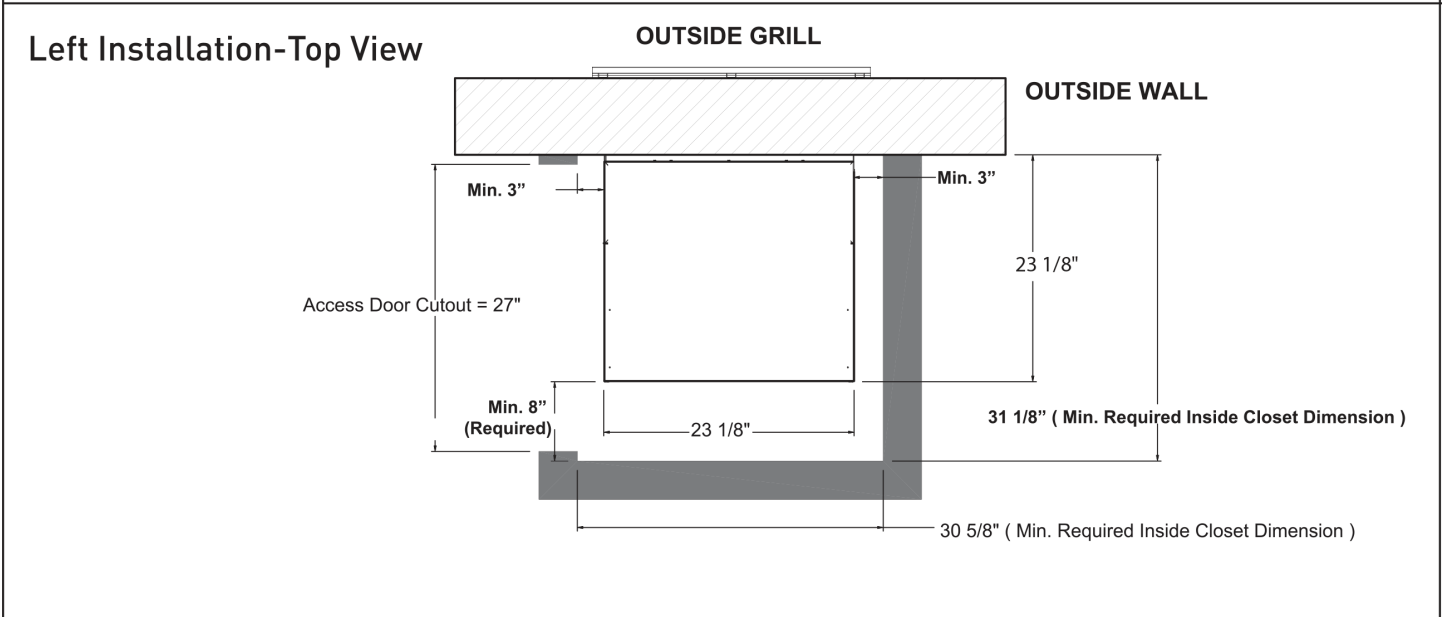
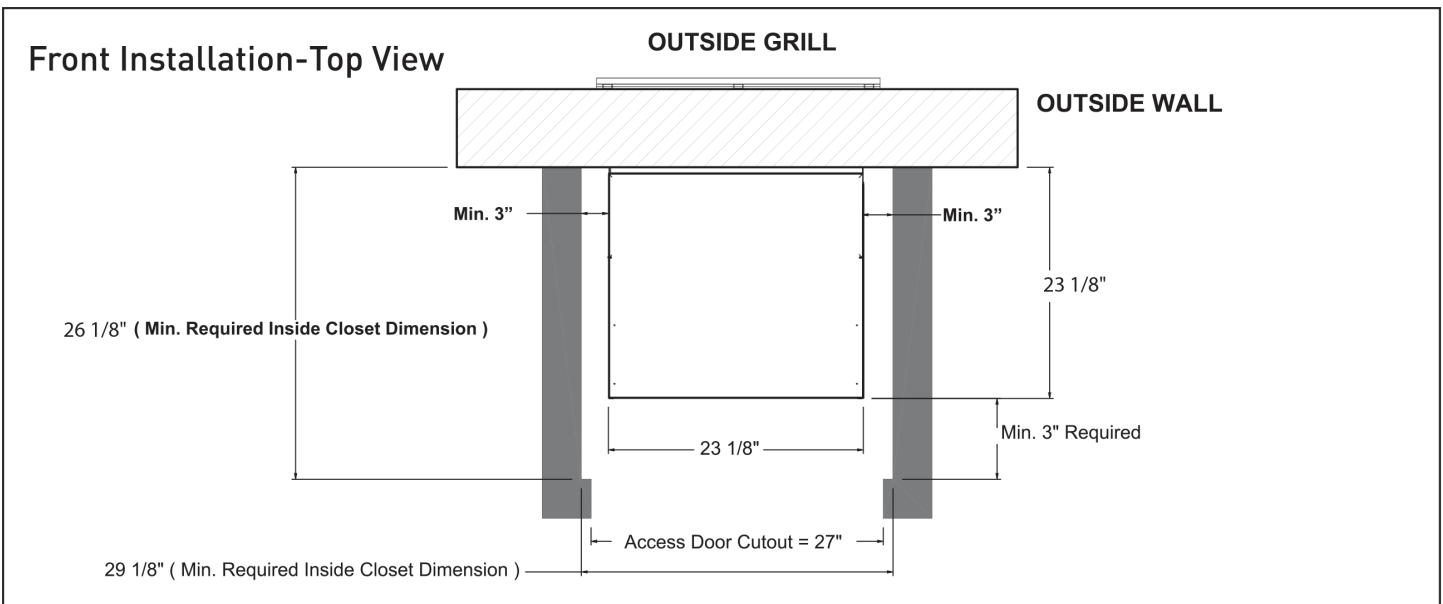

SPECIFICATIONS

CLOSET VIEW

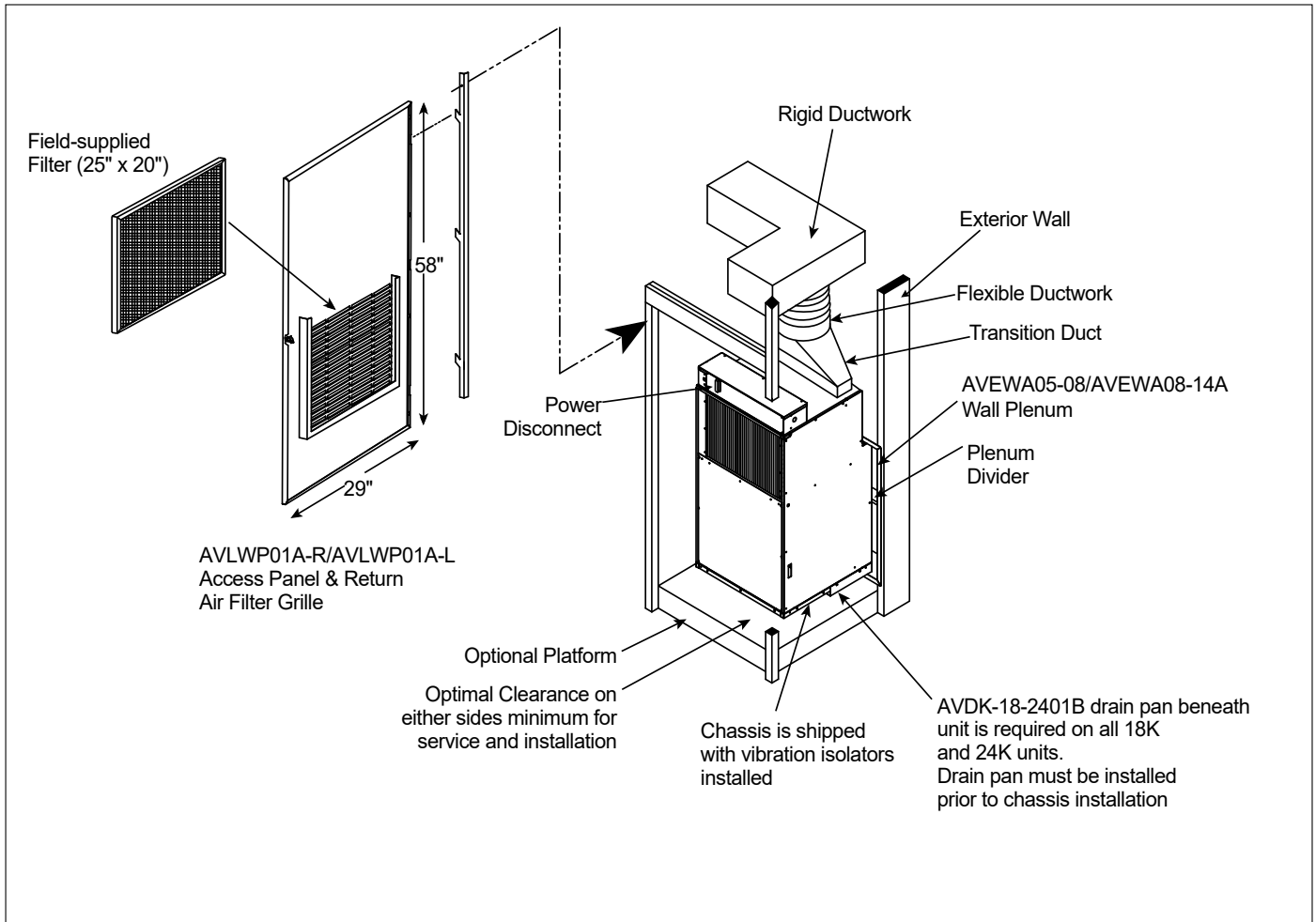

NOTE: IT IS RECOMMENDED THAT 6" OF CLEARANCE IS PROVIDED ON THE SIDE WHERE THE PRIMARY CONDENSATE IS PLUMBED.

SPECIFICATIONS

WALL OPENING DIMENSIONS

Exterior Wall Plenum Cut-Out

Dimensions (W x H):
24 5/8" x 30 7/8"

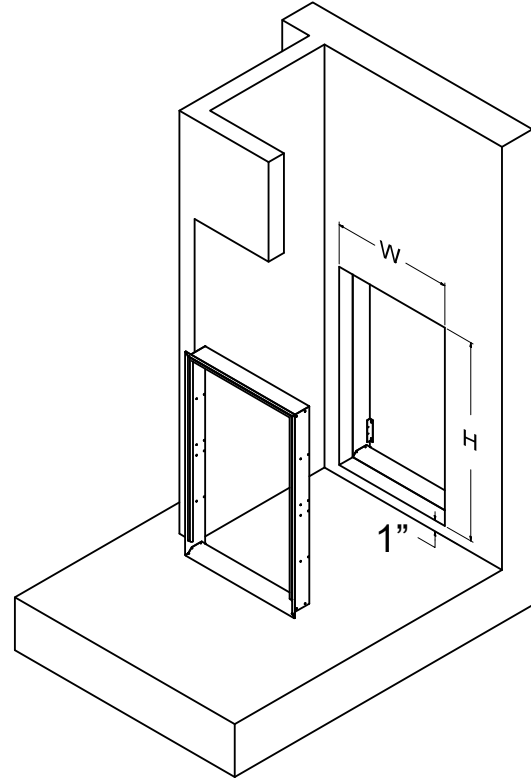

NOTE: The distance between the rough opening and the finished floor/platform must be 1".

Return Air Access Door Wall Cut-Out

Dimensions (W x H):
27" x 55 3/4"

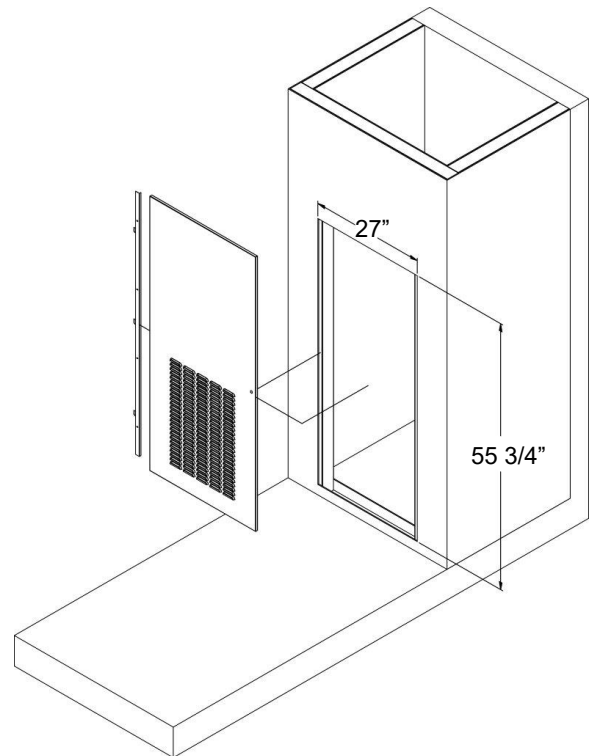

SYSTEM OPERATION

Power-up

When power is applied to the unit (230 VAC), L1 and L2 provide power to energize all relays, contactors, the control boards receive power. 1 phase of the compressor is energized as well. Power is also supplied to the transformer which provides 24 VAC to the thermostat and the defrost control board.

When power is applied to the unit (265 VAC), L1 and L2 provide power to the heater relays, the main transformer which steps down the voltage from 265 VAC to 230 VAC. 230 VAC energizes all other relays, contactors, and control boards. 1 phase of the compressor is energized as well. Power is also supplied to the secondary transformer which provides 24 VAC to the thermostat and the defrost control board.

When power is first applied to the Defrost control board, the defrost timers are reset and the short cycle timer is cleared. All defrost mode calibration is cleared when power is applied to the control. If the power to the control is interrupted for less than 20 milliseconds, the control shall resume operation at the same point in the timing cycle.

The control shall not change modes of operation due to a power interruption of less than 20 milliseconds. Relays may temporarily drop out during the power interruption. Power interruptions greater than 100 milliseconds may reset the control as a power-up sequence. Power interruptions of any duration are not to cause lockout.

Fan only mode

Thermostat sends a G signal to energize the indoor fan motor relay (IMR) closing contacts 2 and 4 providing power to the low voltage tap on the indoor motor controller.

Emergency Heat

If the thermostat provides a W2 signal to the safety relay (SR) it will energize the safety relay which removes power to the compressor and provides power to pin 5 of the indoor fan motor relay (IMR), which provides power to the L1 pin on ID motor controller for ID fan operation.

SEQUENCE OF OPERATION

Simultaneously power is provided to energize the heat relay (HR) and the defrost heat relay (DHR) so that L1 and L2 of the heater phases are energized providing power to the electric heat strips. Basepan heat is also provided at this time.

Compressor Contactor Operation Anti-Short Cycle Delay (ASCD)

The Anti-Short Cycle time Delay is 3-minutes. This delay is active at power up and when the compressor has been de-energized. The ASCD will not be reset during the 30-second compressor delay time after reversing valve change of state.

Compressor Operation

If the control receives a call for compressor operation "Y", in heating or cooling, the compressor contactor output "Y out" will be energized immediately, or immediately after the ASCD timer has expired, whichever occurs last. The control shall de-energize the contactor output immediately when the "Y" signal is removed.

Enable Temperature

If the condenser coil temperature is above 35°F, all defrost functions are disabled.

Ambient Sensor Failure Detection

If the ambient temperature sensor is detected as being open or shorted, the control will operate as shown in Table 5.2.4 Thermistor resistance values greater than 280K ohms (below -35°F) or resistance values less than 3.75K ohms (above 120°F) measured on the ambient sensor will trigger this failure condition.

Condenser Coil Sensor Failure Detection

If the coil temperature sensor is detected as being open or shorted, the control will operate as shown in Table 501. Thermistor resistance values greater than 280K ohms (below -35°F) or resistance values less than 3.75K ohms (above 120°F) measured on the coil sensor will trigger this failure condition.

Ambient probe	Coil Probe	Ambient Temp	Coil Temp	Defrost Action	Defrost Termination
Bad	Good	N/A	<30°F	Begins after 60 minutes accumulated run time	Time/Temp: 14 minutes or Termination Temperature
Bad	Good	N/A	>30°F	No Defrost	N/A
Good	Bad	<42°F	N/A	Begins after 60 minutes accumulated run time	Time/Temp: 14 minutes
Good	Bad	>42°F	N/A	No Defrost	N/A

SYSTEM OPERATION

Compressor Delay Time

At the beginning of the defrost cycle the compressor is shut off for 30 seconds and then the reversing valve is de-energized.

At the end of the defrost cycle, the compressor will be shut off for 30 seconds before the reversing valve is energized.

Following a 30 second delay, the compressor will be turned back on.

Cooling

When powering unit for the first time there is a time delay of 3 minutes. The thermostat energizes the Y out terminal at the defrost control board. The defrost control board will then complete the circuit through the common(cc) to energize the contactor; L1 to T1 on the contactor providing power to the compressor and the outdoor condenser motor.

If the control has "Y" thermostat input present without a "B" input, the compressor output should be active (once the ASCD has expired), and the condenser fan relay contacts (located on the defrost control board) should remain closed.

Low Pressure Switch Operation (Cooling)

Normally Closed. Opens below 30 psig and closes above 50 psig. If the Low Pressure switch opens during cooling operation, the compressor contactor will be de-energized and the ASCD will be reset. During the period with a low pressure switch open, the "Low Pressure Switch Open" fault condition will be displayed as described in Table 701.

High Pressure Switch Operation (Cooling)

Normally Closed. Opens above 675 psig and closes below 475 psig. If the High Pressure switch opens during cooling operation, the compressor contactor will be de-energized and the ASCD will be reset. During the period with a high pressure switch open, the "High Pressure Switch Open" fault condition will be displayed as described in section Table 701. If three High Pressure Switch faults happen within the same call for cooling, the control will lockout the compressor and display the "High Pressure Switch Lockout" fault condition will be displayed on the defrost control board as described in Table 701. If the "Y" thermostat demand is removed, the counter that keeps track of the three pressure switch trips will be reset.

Heating

Heating is same as cooling except thermostat sends B signal to defrost control board which energizes the reversing valve solenoid.

A safety relay is incorporated into the design of the system to prevent emergency heat and the compressor from running simultaneously. Thermostat should not send a B and W2 signal at the same time, however if that happens then W2 will break the signal to defrost control board through the safety relay.

If the control has recognized both "Y" and "B" thermostat inputs present, the compressor contactor should be active (once the ASCD has expired), and the condenser fan relay contacts should remain closed.

SEQUENCE OF OPERATION

Low Pressure Switch Operation (Heating)

Normally Closed. Opens below 30 psig and closes above 50 psig. If the Low Pressure switch opens during heating operation, the compressor contactor will be de-energized and the ASCD will be reset. During the period with a low pressure switch open, the "Low Pressure Switch Open" fault condition will be displayed as described in Table 701.

If three Low Pressure Switch faults happen within a 120 minute period and within the same call for heating, the control will lockout the compressor and display the "Low Pressure Switch Lockout" fault condition will be displayed as described in Table 701. If the "Y" thermostat demand is removed, the counter that keeps track of the three pressure switch trips and the 120 minute period will be reset. The Low pressure switch is ignored the first 90 seconds after the compressor is energized. The Low pressure switch is ignored if the "Y" thermostat demand is removed.

High Pressure Switch Operation (Heating)

Normally Closed. Opens above 675 psig and closes below 475 psig. If the High Pressure switch opens during heating operation, the compressor contactor will be de-energized and the ASCD will be reset. During the period with a High pressure switch open, the "High Pressure Switch Open" fault condition will be displayed as described in Table 701. If three High Pressure Switch faults happen within a 90 minute period and within the same call for heating, the control will lockout the compressor and display the "High Pressure Switch Lockout" fault condition will be displayed as described in Table 701. If the "Y" thermostat demand is removed, the counter that keeps track of the three pressure switch trips and the 90 minute period will be reset. The High pressure switch is ignored if the "Y" thermostat demand is removed.

SYSTEM OPERATION

Defrost Mode Operation

When the unit goes into heat pump mode for the first time and the outdoor coil temp drops below 30 °F it will run a defrost to calibrate the control even though there is no ice build up.

Normally the unit will go into defrost when the outdoor coil temp sensor provides signal to the board below 30 °F and the defrost control board detects a frost condition based on the the calibration point and the ambient temp sensor. At this point the unit will set a timer for 38 minutes and then begin a defrost. The defrost control board sends 24 vac from pin d of the control board to energize the defrost heat relay and close contacts to one strip of electric heat. Basepan heat is also provided at this time. The defrost control board also removes L2 power to fan out, shutting off the outdoor condenser fan motor. Compressor will run during defrost mode.

After the outdoor coil reaches 70 °F or after 14 minutes the defrost cycle will be terminated. The outdoor coil temp defrost finish point can be changed by moving the jumper on the defrost control board to 50, 60, 70, or 80 °F. Factory default is 70 °F.

Defrost Calibration Mode

The control is considered un-calibrated when power is applied to the control, after cool mode operation. Calibration of the controller occurs after a defrost cycle to ensure that there is no ice on the coil. During calibration, the temperature of both the coil and ambient sensors are measured to establish a Dry Coil Delta T. When the controller is in an un-calibrated state, the controller should initiate a sacrificial defrost after 34 minutes of accumulated compressor runtime with coil temperature below 35°F (Enable Temperature). The defrost will terminate if the coil sensor reaches the selected termination temperature or after a 14 minute defrost. If the above defrost was concluded due to termination temperature, or if terminated by time with a coil temperature of greater than the enable Temperature for more than two back-to-back 2-minute transient delay periods, a clear coil (non-iced condition) can be assumed. Otherwise, the control remains in an uncalibrated state.

A stabilized coil would be one that is determined stable after (4) minutes following the defrost cycle allowing the system pressures and temperatures to stabilize. If the coil temperature is not considered stable and the accumulated runtime is ≥ 14 -minutes, the control will operate in time-temperature mode for 90 minutes. Upon the completion of the 90-minute operation the control will initiate a sacrificial defrost. At that point a Dry Coil Delta T at the particular outdoor ambient temperature can be determined. After initial calibration has been completed, the controller prevents a defrost occurrence for 34 minutes of accumulated runtime in order to avoid unnecessary defrost operation due to system transient conditions.

SEQUENCE OF OPERATION

Demand Defrost Operation

The need for a defrost cycle while in Demand Defrost operation is determined by one of two factors: Time or Frost Detection. Should six hours of compressor run time elapse without a defrost cycle and the coil temperature is below the frost accumulation temperature, a defrost will be initiated. If this defrost is terminated on time rather than temperature, the controller shall establish a new Dry Coil Delta T. If the defrost is terminated on temperature the unit will continue with demand mode operations. The compressor run time will be reset when the defrost cycle is complete. The control shall be capable of detecting frost accumulation on the outdoor coil and initiate a defrost when the Dry Coil Delta T + the Coil Temperature Dependant Variable is sensed. As the ambient temperature changes, a slope of 1°F Defrost Delta T change for every 8°F ambient change will be used to adjust the detection of frost accumulation.

Defrost Mode Activation

To activate a defrost sequence, the "B" thermostat input must be active, and the coil temperature must be below 35°F. When these conditions are met, the defrost enable timer tracks the compressor output, and accumulates compressor run time in the heating mode. If the "B" thermostat input is inactive, the defrost enable timer is cleared. If the coil temperature is above 35°F, the defrost enable timer is not cleared, but does not accumulate compressor run time. If the coil temperature is above the selected defrost termination temperature, the defrost enable timer will be cleared. When the defrost enable timer reaches 34 minutes, the defrost mode is enabled. If the control is in the time/temperature defrost operation mode, defrost operation will be initiated immediately. If the control is in demand mode, defrost operation will be initiated as described in defrost demand operation.

Defrost Mode Operation

When operating in the defrost mode, the control will have the compressor contactor, and auxiliary heat outputs activated. The condenser fan relay contacts will be open, de-energizing the fan motor. The accumulated defrost time is monitored while in the defrost mode and compressor is energized. The Low Pressure Switch is ignored during Defrost. When a defrost cycle has been initiated, if the Y thermostat input is removed, the current defrost cycle will be suspended, but the accumulated defrost time is frozen, and the control will resume defrost operation at the start of the next heating cycle (Y active, B active and coil temperature is below 35°F) with a minimum of the ASCD between compressor activations. The accumulated defrost time resumes when the compressor output is re-energized. The defrost relay will de-energize when the Y thermostat input is removed and energize when the Defrost is resumed.

SYSTEM OPERATION

SEQUENCE OF OPERATION

Defrost Mode Termination

Once a defrost mode has been initiated, it shall be terminated immediately and reset the internal timing if the coil sensor temperature exceeds the selected termination temperature. If the temperature select jumper is not installed, the default termination temperature shall be 50°F. The Low Pressure Switch is ignored for 90 seconds following termination of a Defrost. Once a defrost mode has been initiated, an internal timer shall count the time that the defrost mode is engaged and compressor is energized. After 14 minutes of operation in the defrost mode, the defrost sequence shall terminate immediately and reset internal timing regardless of the state of the coil sensor temperature. If a defrost cycle is terminated by time and the coil temperature did not remain above 90°F for 14 minutes, the controller will return to an un-calibrated state.

Forced Defrost

When the "TEST" terminals are shorted with the "Y" and "B" inputs active, the ASCD timer will be canceled and control will enter the defrost mode. If the short on the "TEST" terminals is removed and then reapplied, the defrost mode will be exited and the control will return to heating operation. These modes can continue to be cycled through by removing and reapplying the short to the "TEST" terminals. The Compressor Delay Time (30 Seconds) will remain active when switching between defrost mode and heat mode with the test feature.

The Enable Temperature is ignored when the "TEST" terminals are shorted, and a forced defrost can be entered with the coil temperature above the Enable Temperature (35°F). The forced defrost will terminate when either the coil temperature exceeds the selected Termination Temperature, 14 minutes of defrost has accumulated, or the test terminals are shorted a second time.

Blower Control

All VTAC, by default, will be configured to low speed blower operation. The speed setting can be changed to high speed by updating the speed tap settings on the fan control relay.

NOTE: The fan speed setting cannot be changed at the thermostat. Regardless of wiring GH and/or GL, the unit will continue to operate at the speed setting at the fan control relay. To change fan speed from low to high change the speed relay tap from red to blue wire.

NOTE: THERMOSTATS THAT HAVE HIGH AND LOW TERMINALS MUST BE JUMPED AT THE THERMOSTAT FOR PROPER OPERATION.

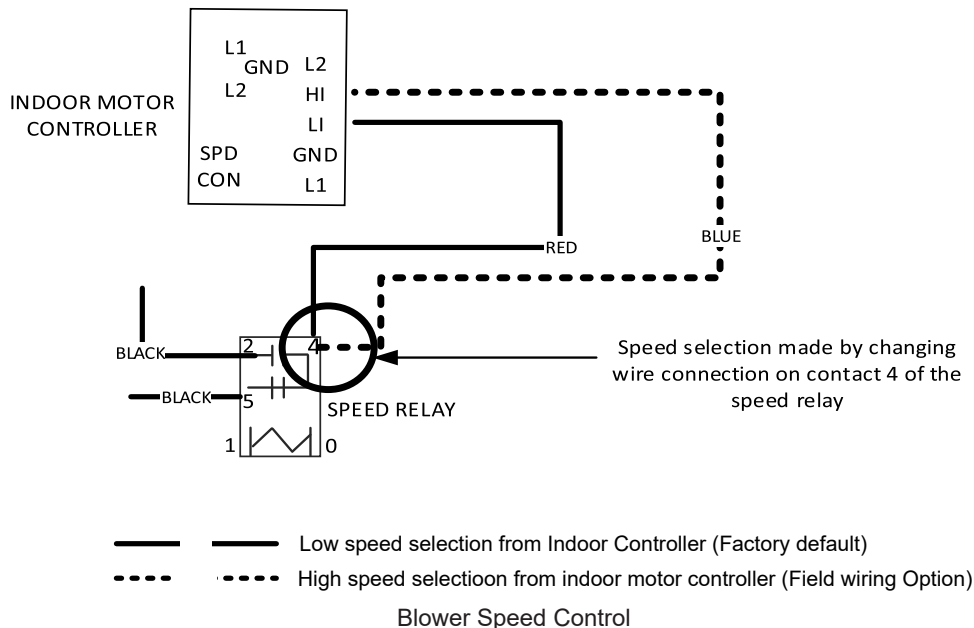

SYSTEM OPERATION

Inputs

C - 24 VAC Common

R - 24 VAC Output (Power Supply) supplied via the transformer to the thermostat.

Y - 24 VAC thermostat input for compressor demand - Thermostat Call for Compressor ("Y"). This signal is monitored by the control logic, and is recognized as active when "R" is connected to "Y". Inputs of less than 11 VAC will not be detected as active.

B - 24 VAC thermostat input for reversing valve demand. Thermostat Call for Reversing Valve ("B"). This signal is monitored by the control logic, and is recognized as active when "R" is connected to "B" at the thermostat. The input signal is connected through the normally closed relay contacts of K1 on the defrost control board to the "RV" quick connect terminal.

P3 – Connections for outdoor ambient temperature sensor. Ambient Temperature Sensor ("AMB") The ambient temperature sensor is a thermistor input. In addition to measuring the temperature value of the thermistor, the control shall detect an open thermistor condition, and a shorted thermistor condition.

P4 - Connections for the Condenser temperature sensor: Coil Temperature Sensor ("COIL"). The coil temperature sensor is a thermistor input. In addition to measuring the temperature value of the thermistor, the control shall detect an open thermistor condition, and a shorted thermistor condition.

P1 - 5 position, P1 provides selection of the defrost terminate temperature based on the position of selection shunt. Selections include 50°F, 60°F, 70°F, and 80°F. If the temperature shunt is not installed, the default termination temperature shall be 50°F. The control shall be provided from the factory with the temperature shunt installed in the 70°F position.

HPC -High pressure switch input. The high-pressure switch input is a 24 VAC input. The input is supplied from the "Y" thermostat input, is in series with the compressor contactor output, and is monitored by the control logic. The hp switch Opens above 675 psig and closes below 475 psig.

LPC - The low-pressure switch input is a 24 VAC input. The input is supplied from the "Y" thermostat input, is in series with the compressor contactor output, and is monitored by the control logic. The lp switch opens below 30 psig and closes above 50 psig.

Outputs

Y out - The Y out "Y" terminal is sourced 24 VAC from the "Y" input terminal of the thermostat

CC out - Switched compressor contactor 24 VAC common CC" terminal. CC out is removed during compressor lockout, if hi or low pressure switches open, or 3 minute time delay

Reversing Valve ("RV") B out

(RV) Switched 24 VAC to reversing valve.

(C) 24 VAC common to reversing valve.

The control provides a pilot duty 24 VAC output for the reversing valve. This output provides a normally closed relay connection between the "B" and "RV" terminals. This connection is opened during a defrost cycle.

D - 24 VAC auxiliary heat output (sourced from Y input) The control provides a pilot duty 24 VAC output during defrost operation which activates the defrost relay. For defrost operation of the auxiliary heat, the "D" output is connected to the 24 VAC through the high pressure switch which is sourced by the "Y" thermostat input.

DEFROST CONTROL BOARD

FAN - 240 VAC line voltage source for PSC condenser fan. The control provides a 240 VAC line voltage output for the condenser fan. The condenser fan output is a normally closed relay contact output. During the defrost operation, the normally closed contacts of the K2 relay on the defrost control board will be opened.

Diagnostic Indicator LED ("LED1" & "LED2")

Two red LED's are provided to display diagnostic codes for the control.

SYSTEM OPERATION

Remote Wall Thermostat Location

The thermostat should not be mounted where it may be affected by drafts, discharge air from registers (hot or cold), or heat radiated from the sun, appliances, windows etc.. The thermostat should be located about 3-5 Ft. above the floor in an area of average temperature, with good air circulation. Thermostats should be level for aesthetics.

NOTE: AN IMPROPERLY OPERATING OR POORLY LOCATED REMOTE WALL THERMOSTAT CAN BE THE SOURCE OF PERCEIVED EQUIPMENT PROBLEMS. A CAREFUL CHECK OF THE THERMOSTAT'S LOCATION AND WIRING MUST BE MADE TO ENSURE THAT IT IS NOT THE SOURCE OF PROBLEMS.

Remote Thermostat

This unit is configured to be controlled by using a single stage cool - dual stage heatpump remote wall mounted thermostat. The thermostat may be auto or manual changeover as long as the control configuration matches that of the VTAC unit.

To connect the wall mounted thermostat:

1. Pull the disconnect switch.
2. Unscrew and remove the control box panel.
3. Select which side to route your thermostat wire.
4. Route the wires through the side hole in the box to reach the connection terminal wiring.
5. Make the connections, appropriately matching the wires as shown in the wiring diagram.
6. Reattach the control box cover.

Terminal Code	Wire Connection Function
C	Common Ground Terminal
G	Call for Fan*
B	Reenergized for Heat (Reversing Valve)
Y	Call for Compressor
W2	Second Stage Heat
R	24 VAC to Wall Thermostat

Thermostat Connections

NOTE: IT IS THE INSTALLER'S RESPONSIBILITY TO ENSURE THAT ALL CONTROL WIRING CONNECTIONS ARE MADE IN ACCORDANCE WITH THE INSTALLATION INSTRUCTIONS. IMPROPER CONNECTION OF THE THERMOSTAT CONTROL WIRING AND/OR TAMPERING WITH THE UNIT'S INTERNAL WIRING MAY RESULT IN PROPERTY DAMAGE, PERSONAL INJURY, OR DEATH. QUESTIONS CONCERNING PROPER CONNECTIONS TO THE UNIT SHOULD BE DIRECTED TO DAIKIN.

REMOTE THERMOSTAT CONNECTION

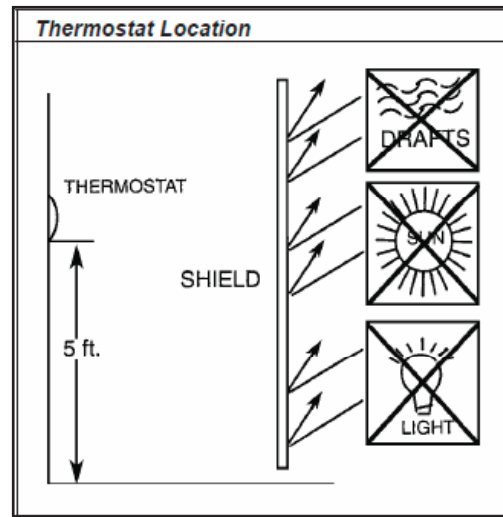

Thermostat Location

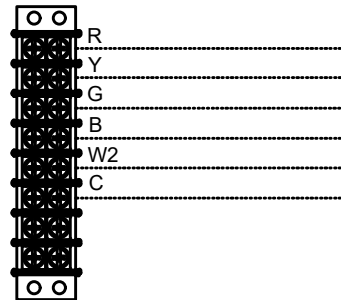

Low Voltage Connections

SYSTEM OPERATION

GENERAL KNOWLEDGE SEQUENCE OF REFRIGERATION

A good understanding of the basic operation of the refrigeration system is essential for the service technician. Without this understanding, accurate troubleshooting of refrigeration system problems will be more difficult and time consuming, if not (in some cases) entirely impossible. The refrigeration system uses four basic principles in its operation which are as follows:

1. "Heat always flows from a warmer body to a cooler body."
2. "Heat must be added to or removed from a substance before a change in state can occur"
3. "Flow is always from a higher pressure area to a lower pressure area."
4. "The temperature at which a liquid or gas changes state is dependent upon the pressure."

The refrigeration cycle begins at the compressor when a demand is received from the thermostat. Starting the compressor creates a low pressure in the suction line which draws refrigerant gas (vapor) into the compressor. The compressor then "compresses" this refrigerant vapor, creating a superheated state.

The refrigerant leaves the compressor through the discharge line as a hot high pressure gas (vapor). The refrigerant enters the condenser coil where it gives up some of its heat. The condenser fan moving air across the coil's finned surface facilitates the transfer of heat from the refrigerant to the relatively cooler outdoor air.

When a sufficient quantity of heat has been removed from the refrigerant gas (vapor), the refrigerant will "condense" (i.e. change to a liquid). Once the refrigerant has been condensed (changed) to a liquid it is sub-cooled by the air that continues to flow across the condenser coil.

The design determines at exactly what point (in the condenser) the change of state (i.e. gas to a liquid) takes place. In all cases, however, the refrigerant must be totally condensed (changed) to a liquid before leaving the condenser coil.

The refrigerant leaves the condenser coil through the liquid line as a high pressure high temperature liquid.

The liquid refrigerant next enters the metering device. The metering device on this unit is a Thermal Expansion Valve (TXV). The purpose of the metering device is to "meter" (i.e. control or measure) the quantity of refrigerant entering the evaporator coil and maintain superheat.

The TXV has a sensing bulb installed on the suction line. The bulb is filled with a liquid cross charge. Maintains superheat by sensing the suction line temp.. and modulating the flow of refrigerant to the evaporator coil.

As it enters the evaporator coil, the larger area and lower pressure allows the refrigerant to expand and lower its temperature (heat intensity). This expansion is often referred to as "boiling" or atomizing. Since the unit's blower is moving indoor air across the finned surface of the evaporator coil, the expanding refrigerant absorbs some of that heat. This results in a lowering of the indoor air temperature, or cooling.

The expansion and absorbing of heat cause the liquid refrigerant to evaporate (i.e. change to a gas). Once the refrigerant has been evaporated (changed to a gas), it is superheated by the air that continues to flow across the evaporator coil.

The particular system design determines at exactly what point (in the evaporator) the change of state (i.e. liquid to a gas) takes place. In all cases, however, the refrigerant must be totally evaporated (changed) to a gas before leaving the evaporator coil.

The low pressure (suction) created by the compressor causes the refrigerant to leave the evaporator through the suction line as a superheated vapor. The refrigerant then returns to the compressor, where the cycle is repeated.

REMOVE AND INSTALL THE CHASSIS



WARNING

ELECTRICAL SHOCK HAZARD
TURN OFF ELECTRIC POWER BEFORE SERVICE OR INSTALLATION.
UNIT MUST BE PROPERLY GROUNDED.
UNIT MUST HAVE CORRECT FUSE OR CIRCUIT BREAKER PROTECTION. UNIT'S SUPPLY CURCUIT MUST HAVE THE CORRECT WIRE CONDUCTOR SIZE. ALL ELECTRICAL CONNECTIONS AND WIRING MUST BE INSTALLED BY A QUALIFIED ELECTRICIAN AND CONFORM TO THE NATIONAL ELECTRICAL CODE AND ALL LOCAL CODES WHICH HAVE JURISDICTION. FAILURE TO DO SO CAN RESULT IN PROPERTY DAMAGE, PERSONAL INJURY AND/OR DEATH.



CAUTION

CUT/SEVER HAZARD
SOME EDGES MAY BE SHARP.
USE GLOVES OR OTHER HAND PROTECTION WHEN HANDLING THE UNIT.
FAILURE TO DO SO CAN RESULT IN MINOR TO MODERATE PERSONAL INJURY.

Servicing / Chassis Quick Changeouts

The chassis is designed for quick disconnect and change out. For minor electrical service, the control box cover lifts straight up after the screws & disconnect head are removed. For major electrical, refrigeration and fan service the chassis may be removed from utility closet.

To Remove the Chassis from the Closet:

1. Switch off the power coming into the unit from the main breaker panel or the closet mounted disconnect.
2. Switch the wall Thermostat off.
3. Pull the Power Disconnect located in the front of the chassis.
4. Disconnect the L1 and L2 electrical connections and remove conduit from chassis.
5. Disconnect low voltage thermostat connections.
6. Disconnect the duct work.
7. Disconnect condensate drain
8. Slide the chassis out of the wall plenum.

CAUTION:

DO NOT TEAR GASKET DURING REMOVAL.

9. Remove the chassis out of the utility closet.

Reinstallation

1. Installation is the reverse of the removal above.
2. Verify that the unit is level after installation. Adjust as required.

EXTERNAL STATIC PRESSURE

External Static Pressure can best be described as the pressure difference (drop) between the Positive Pressure (discharge) and the Negative Pressure (intake) sides of the blower. External Static Pressure is developed by the blower as a result of resistance to airflow (Friction) in the air distribution system EXTERNAL to the VTAC cabinet.

Resistance applied externally to the VTAC (i.e. duct work, filters, etc.) on either the supply or return side of the system causes an INCREASE in External Static Pressure accompanied by a REDUCTION in airflow.

External Static Pressure is affected by two factors.

1. Resistance.
2. Blower Speed (Changing to a higher or lower blower speed will raise or lower the External Static Pressure accordingly).

These affects must be understood and taken into consideration when checking External Static Pressure/Airflow to insure that the system is operating within design conditions.

Operating a system with insufficient or excessive airflow can cause a variety of different operating problems. Among these are problems such as, reduced capacity, freezing evaporator coils, premature compressor' heating component failures, and/ or other air local distribution issues.

System airflow should always be verified upon completion of a new installation, or before a change-out, compressor replacement, or in the case of heat strip failure to insure that the failure was not caused by improper airflow.

Checking External Static Pressure

The airflow through the unit can be determined by measuring the external static pressure of the system, and consulting the blower performance data for the specific VTAC.

1. Set up to measure external static pressure at the supply and return air.
2. Ensure the coil and filter are clean, and that all the registers are open.
3. Determine the external static pressure with the blower operating.

Use a digital manometer to measure. The supply measurement should be taken roughly 3-6" from the VTAC collar and the return measurement taken from center of the indoor coil with the filter installed.

NOTE: ENSURE THAT THE CLOSET DOOR IS CLOSED. FAILURE TO CLOSE CLOSET DOOR WILL RESULT IN ERRONEOUS READINGS.

4. Refer to the Air Flow Data for your VTAC system to find the actual airflow for factory-selected fan speeds.
5. If the actual airflow is either too high or too low, the blower speed will need to be changed to appropriate setting or the ductwork will need to be reassessed and corrections made as required.
6. Select a speed, which most closely provides the required airflow for the system.
7. Recheck the external static pressure with the new speed. External static pressure (and actual airflow) will have changed to a higher or lower value depending upon speed selected. Recheck the actual airflow (at this "new" static pressure) to confirm speed selection.
8. Repeat steps 7 and 8 (if necessary) until proper airflow has been obtained.

EXAMPLE: Airflow requirements are calculated as follows: (Having a wet coil creates additional resistance to airflow. This additional resistance must be taken into consideration to obtain accurate airflow information.

Determining the Indoor CFM						
MODEL	AVH 09/12		AVH 18		AVH 24	
FAN SPEED	LOW	HIGH	LOW	HIGH	LOW	HIGH
ESP (")	CFM					
0.0"	470	520	730	800	755	805
0.05"	460	510	670	735	700	750
*0.10"	430	490	630	675	660	700
0.15"	140	470	595	640	615	665
0.20"	360	440	550	600	575	625
0.25"	310	400	505	550	525	580
0.30"	260	350	455	500	485	540
0.35"	--	--	400	445	450	500
0.40"	--	--	345	400	415	465

*values indicate rated performance point

EXTERNAL STATIC PRESSURE

Correct CFM (if needed) : Correction Multipliers	
230V	1.00
208V	0.97
265V	--
Heating	1.00
Cooling	0.95

Correction Multiplier

Explanation of Tables

Table on page 23 is the nominal dry coil VTAC CFMs. Table shown above is the correction factors beyond nominal conditions.
1 ½ TON SYSTEM (18,000 Btu)

Operating on high speed @ 230 volts with dry coil.
measured external static pressure .10

Air Flow = 450 CFM

In the same SYSTEM used in the previous example but having a WET coil you must use a correction factor of .95 (i.e. 450 x .95=428 CFM) to allow for the resistance (internal) of the condensate on the coil.

It is important to use the proper procedure to check external Static Pressure and determine actual airflow. Since in the case of the VTAC, the condensate will cause a reduction in measured External Static Pressure for the given airflow.

It is also important to remember that when dealing with VTAC units that the measured External Static Pressure increases as the resistance is added externally to the cabinet. Example: duct work, filters, grilles.

Indoor Airflow Data

The VTAC A series units must be installed with a free return air configuration. Table on page 23 lists the indoor airflow at corresponding static pressures. All units are rated at low speed.

Ductwork Preparation

If flex duct is used, be sure all the slack is pulled out of the flex duct. Flex duct ESP can increase considerably when not fully extended. DO NOT EXCEED a total of .30 ESP, as this is the MAXIMUM design limit for the VTAC A-Series unit.

IMPORTANT: FLEX DUCT CAN COLLAPSE AND CAUSE AIRFLOW RESTRICTIONS. DO NOT USE FLEX DUCT FOR: 90 DEGREE BENDS, OR UNSUPPORTED RUNS OF 5 FT. OR MORE.

EXTERNAL STATIC PRESSURE

Fresh Air Door

The Fresh Air Door is an "intake" system. The fresh air door opened via a slide on the front of the chassis located just above the indoor coil. Move the slide left to open and right to close the fresh air door. The system is capable of up to 60 CFM of fresh air @ ~.3" H2O internal static pressure.

Checking Approximate Airflow

If a digital manometer is not available to check the External Static Pressure, or the blower performance data is unavailable for your unit, approximate airflow can be calculated by measuring the temperature rise, then using the following criteria.

$$\text{CFM} = \frac{\text{Kilowatts} \times 3413}{\text{Temp Rise} \times 1.08}$$

Electric Heat Strips

The approximate CFM actually being delivered can be calculated by using the following formula:

DO NOT simply use the Kilowatt Rating of the heater (i.e. 2.5, 3.4, 5.0) as this will result in a less-than-correct airflow calculation.

Kilowatts may be calculated by multiplying the measured voltage to the unit (heater) times the measured current draw of all heaters (ONLY) in operation to obtain watts. Kilowatts are then obtained by dividing by 1000.

EXAMPLE: Measured voltage to unit (heaters) is 230 volts.

Measured Current Draw of strip heaters is 11.0 amps.

$$230 \times 11.0 = 2530$$

$$2530/1000 = 2.53 \text{ Kilowatts}$$

$$2.53 \times 3413 = 8635$$

Supply Air = 95°F

Return Air = 75°F

Temperature Rise = 20°F

$$20 \times 1.08 = 21.6$$

$$\frac{8635}{21.6} = 400 \text{ CFM}$$

$$21.6$$

TROUBLESHOOTING

CONTROL DIAGNOSTIC MODES

Diagnostic Description	LED 1	LED 2	Solution
Control Fault (No Power)	OFF	OFF	Confirm incoming voltage, if present replace the board.
Normal Operation	FLASH	FLASH	Normal operation.
Anti-Short Cycle Delay	ALTERNATING FLASH		Wait for short cycle to expire. Approximately 3-minutes.
Coil Sensor Failure	ON	ON	<ol style="list-style-type: none"> 1. An open or shorted sensor is detected. 2. Confirm connection points. 3. Ohm out sensor to confirm if open (OL) or shorted (0.0 Ohms). If ok replace the board.
Ambient Sensor Failure	OFF	ON	<ol style="list-style-type: none"> 1. An open or shorted sensor is detected. 2. Confirm connection points. 3. Ohm out sensor to confirm if open (OL) or shorted (0.0 Ohms). If ok replace the board.
Low Pressure Switch Open	ON	FLASH	<ol style="list-style-type: none"> 1. Possible faulty pressure switch. 2. Confirm connection points. 3. Suction line pressure is too low. Confirm system pressures and operation, address as needed. 4. In cooling possible indoor blower not running or insufficient airflow. Check filters and for blockage. 5. Check for low refrigerant. 6. Check for clogged evaporator.
Low Pressure Switch Lockout	OFF	FLASH	<ol style="list-style-type: none"> 1. Possible faulty pressure switch. 2. Confirm connection points. 3. Suction line pressure is too low. Confirm system pressures and operation, address as needed. 4. In cooling possible indoor blower not running.
High Pressure Switch Open	FLASH	ON	<ol style="list-style-type: none"> 1. Possible faulty pressure switch. 2. Confirm connection points. 3. Discharge pressure too high. Confirm system pressures and operation, address as needed. 4. In cooling possible outdoor condensing fan motor not running. 5. Check for refrigerant restriction. 6. Wall sleeve baffles not in place or adjusted properly. 7. Insufficient condenser airflow. 8. Check for plugged condenser coil. 9. Wall sleeve baffles not in place or adjusted properly.
High Pressure Switch Lockout	FLASH	OFF	<ol style="list-style-type: none"> 1. Possible faulty pressure switch. 2. Confirm connection points. 3. Discharge pressure too high. Confirm system pressures and operation, address as needed. 4. In cooling possible outdoor condensing fan motor not running. 5. Lockout will reset after the Y call is removed. 6. Check for refrigerant restriction. 7. Insufficient condenser airflow. 8. Check for plugged condenser coil.

COMPONENT IDENTIFICATION

ELECTRICAL CONTROL BOX 9K & 12K (FRONT)

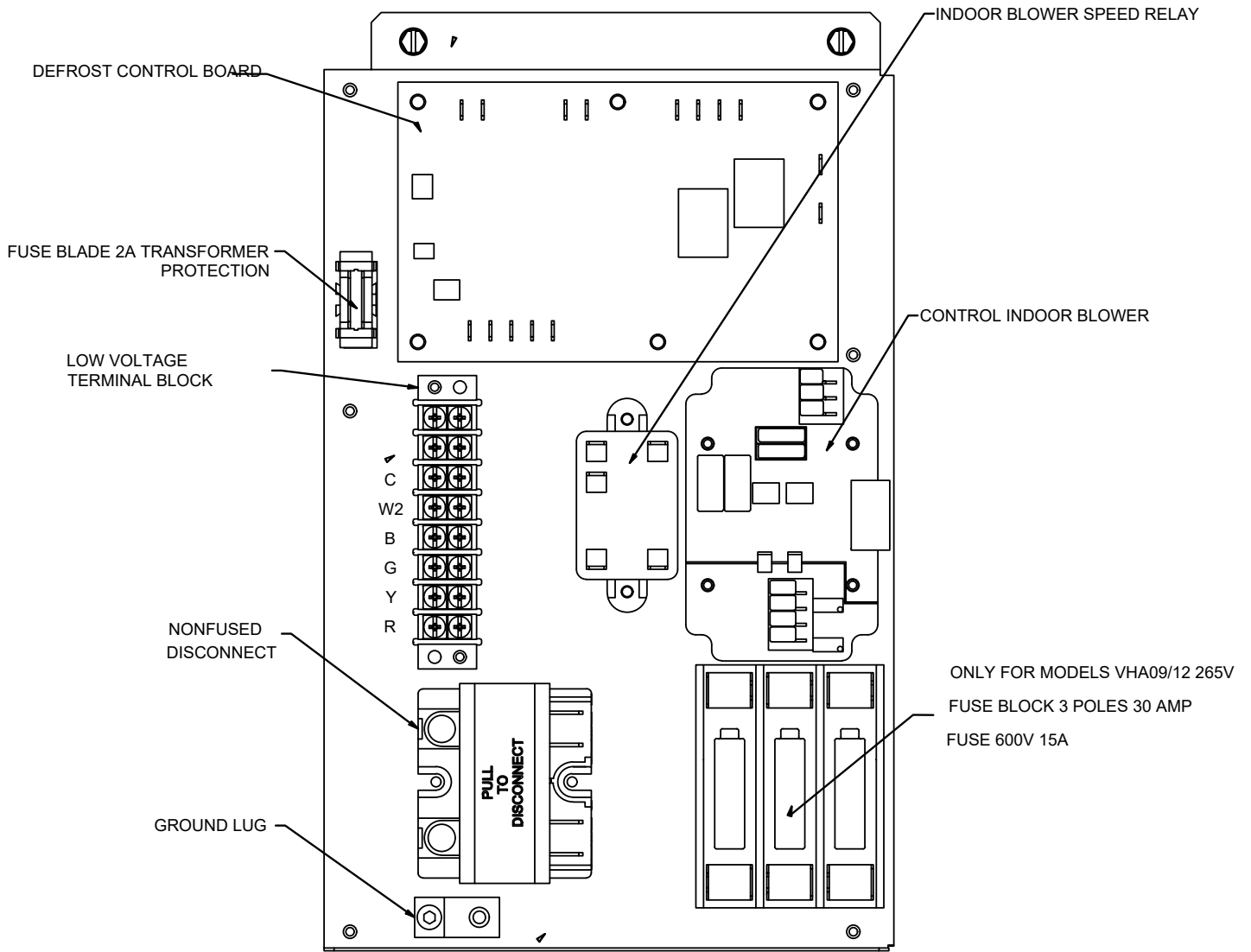

9K & 12K Volt Electrical Box

COMPONENT IDENTIFICATION

ELECTRICAL CONTROL BOX 9K & 12K (REAR)

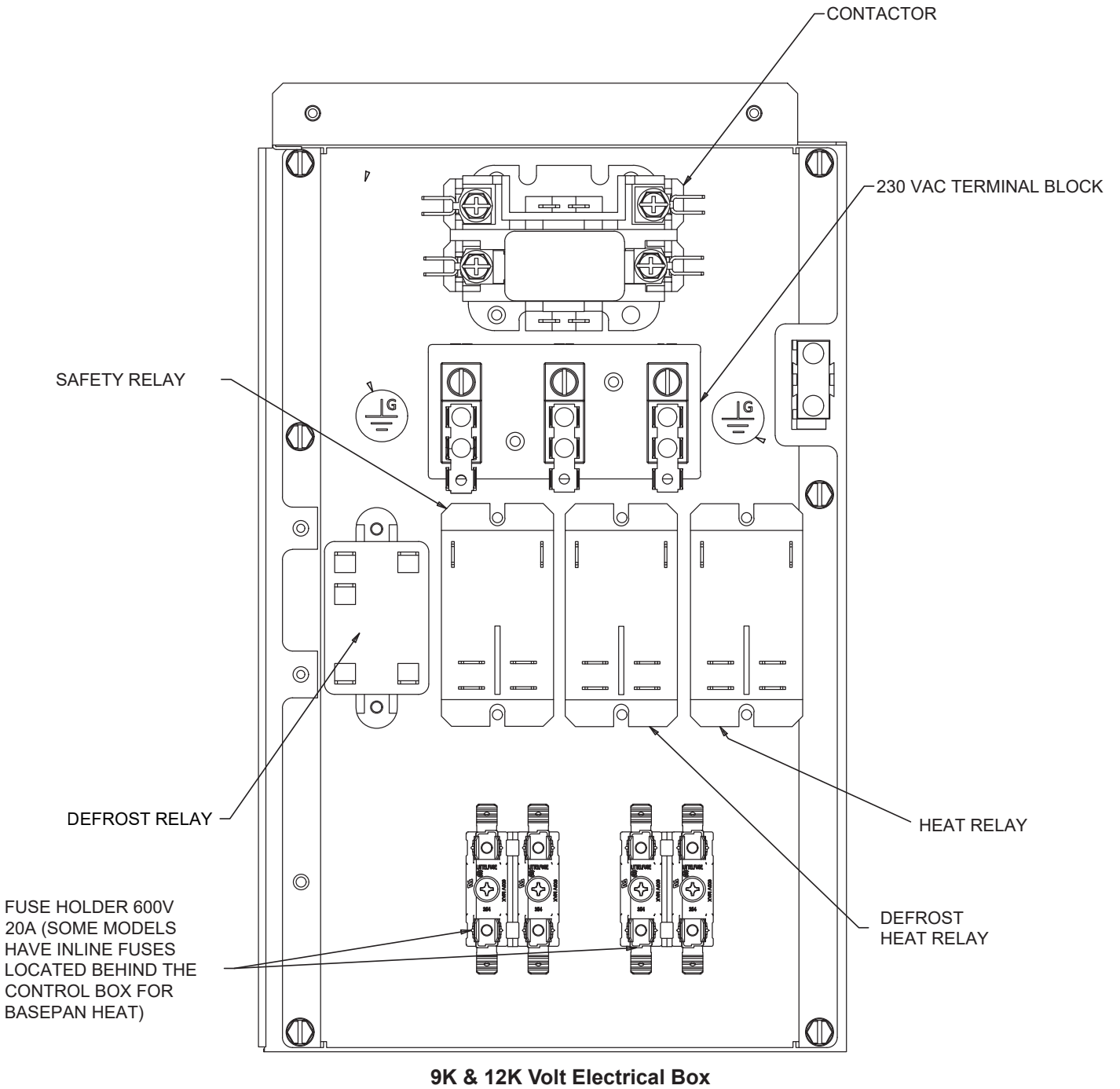

COMPONENT IDENTIFICATION

ELECTRICAL CONTROL BOX 18K & 24K

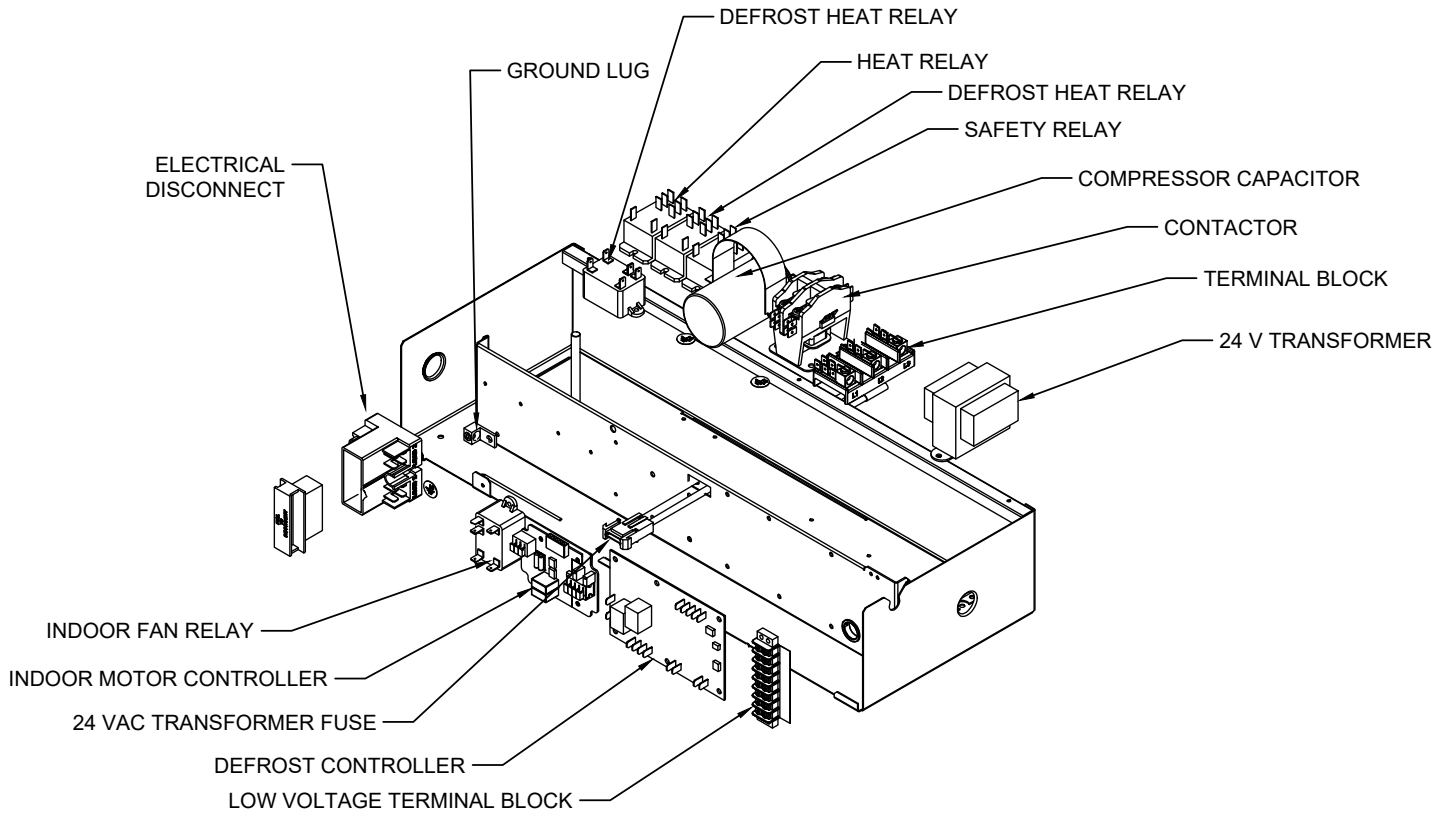

18K & 24K Electrical Box

COMPONENT IDENTIFICATION

DEFROST CONTROL BOARD

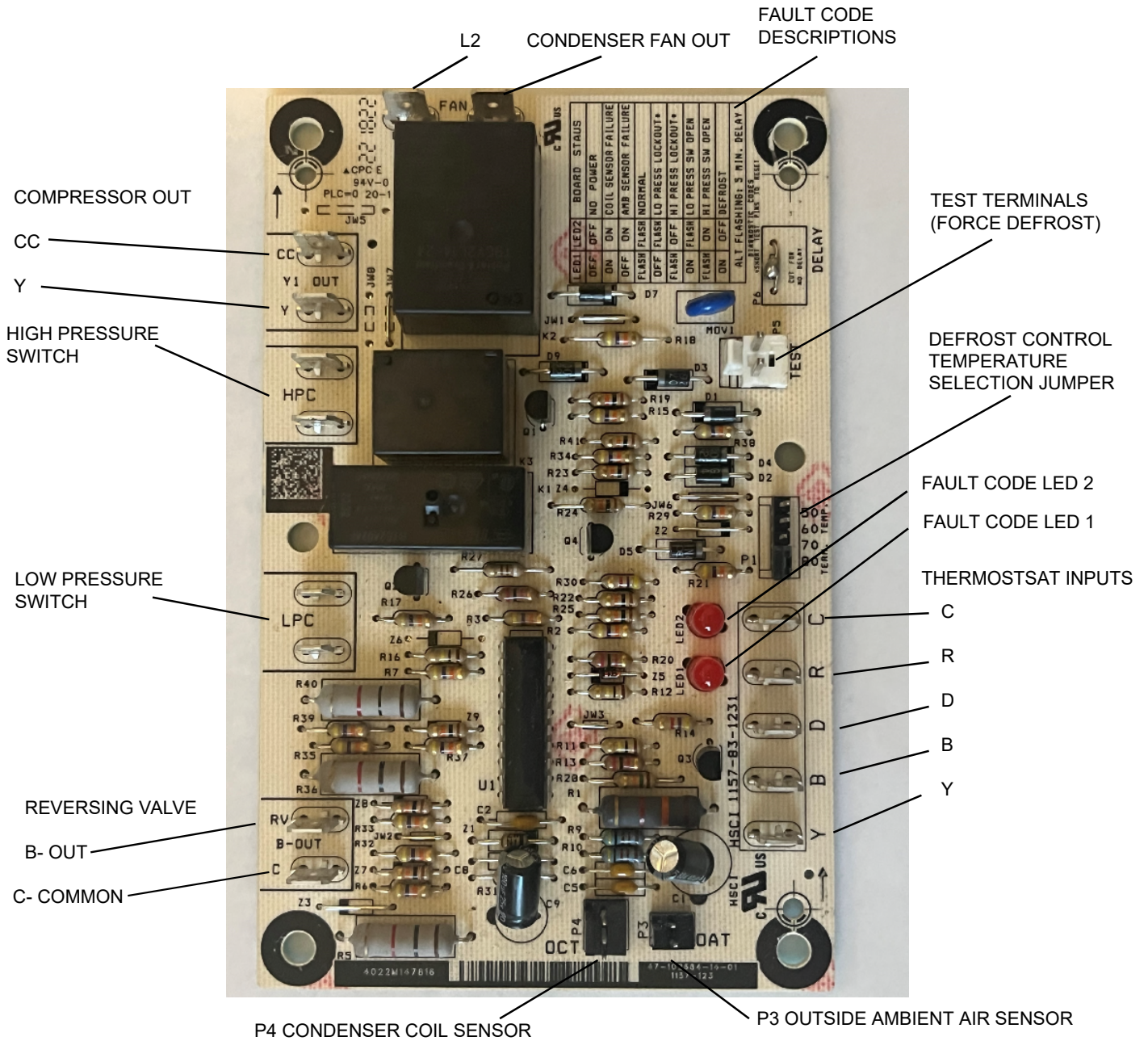

Defrost Control Board Identification

COMPONENT IDENTIFICATION



9 & 12K ELECTRIC BOX READINGS

WARNING: IF CHECKING LIVE CIRCUIT IS NECESSARY RE-CONNECT LINE VOLTAGE ALONG WITH GROUND WIRE AND UNDERSTAND THAT CAUTION SHOULD BE TAKEN NOT TO SHORT OUT ANY CIRCUITS TO EACH OTHER AND THE EQUIPMENT PANELS AS ALL CIRCUITS WILL BE LIVE AND CAPABLE OF DELIVERING HIGH CURRENT AND VOLTAGE. INSULATED TOOLS AND METER LEADS ARE RECOMMENDED. ALONG WITH PROPER PPE. DE-ENERGIZE THE EQUIPMENT IF LIVE TESTING IS NOT BEING PERFORMED AND VISUALLY INSPECT ALL WIRES BEFORE ENERGIZING. SAFETY SHOULD ALWAYS BE YOUR TOP PRIORITY WHEN WORKING WITH LIVE ELECTRICAL CIRCUITS. ALWAYS FOLLOW SAFE WORK PRACTICES AND USE THE RIGHT TOOLS AND EQUIPMENT ACCESS REAR ELECTRICAL PANEL TO TAKE ELECTRICAL READINGS

In order to access the relays and terminals on the back half of the box – the panel needs to be pulled back.

To take electrical Readings:

1. Remove electrical box cover.
2. Remove power from unit by opening disconnect, circuit breaker or fuse.
3. Disconnect L1 and L2 input wiring.
4. Remove 3 mounting screws and rotate panel to a 45° angle.
5. Re-connect L1 and L2 wires.
6. Apply power to unit.
7. Take power readings.
8. Remove power.
9. Disconnect power.
10. Rotate panel back and install screws.
11. Connect wires.
12. Close disconnect, circuit breaker, or fuse to apply power to unit.

 WARNING	
<p>ELECTRICAL SHOCK HAZARD TURN OFF ELECTRIC POWER BEFORE SERVICE OR INSTALLATION. UNIT MUST BE PROPERLY GROUNDED. UNIT MUST HAVE CORRECT FUSE OR CIRCUIT BREAKER PROTECTION. UNIT'S SUPPLY CURCUIT MUST HAVE THE CORRECT WIRE CONDUCTOR SIZE. ALL ELECTRICAL CONNECTIONS AND WIRING MUST BE INSTALLED BY A QUALIFIED ELECTRICIAN AND CONFORM TO THE NATIONAL ELECTRICAL CODE AND ALL LOCAL CODES WHICH HAVE JURISDICTION. FAILURE TO DO SO CAN RESULT IN PROPERTY DAMAGE, PERSONAL INJURY AND/OR DEATH. LIVE READINGS WILL NEED TO BE TAKEN. EXERSIZE EXTREME CAUTION WHEN WORKING WITH LIVE ELECTRICAL CIRCUITS</p>	

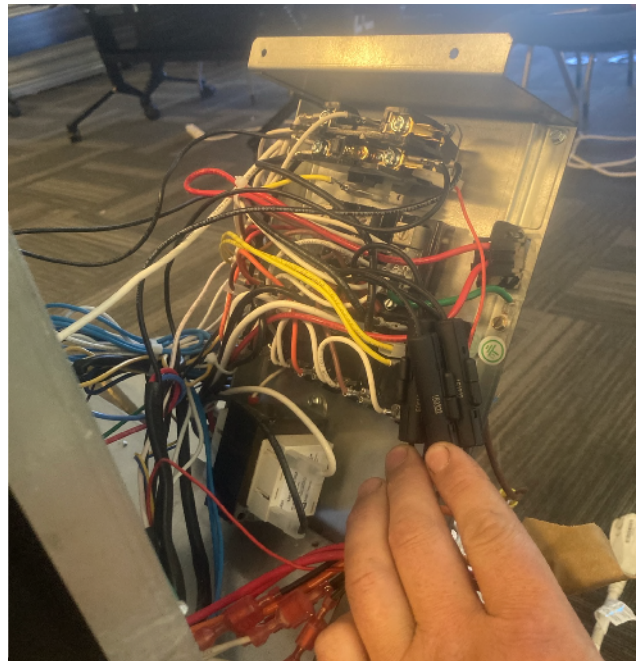

9K and 12K Electrical Box

COMPONENT IDENTIFICATION

Reversing Valve

A reversing valve is a component of a heat pump that changes the direction of refrigerant flow, allowing the system to function in both heating and cooling modes.

It consists of a pressure-operated, main valve and a pilot valve actuated by a solenoid plunger. The solenoid is energized by 24 vac during the heating cycle only.

The single tube on one side of the main valve body is the high-pressure inlet to the valve from the compressor. The center tube on the opposite side is connected to the low pressure (suction) side of the compressor. The other two are connected to the indoor and outdoor coils. Small capillary tubes connect each end of the main valve cylinder to the "A" and "B" ports of the pilot valve. A third capillary is a common return line from these ports to the suction tube on the main valve body. Four-way reversing valves also have a capillary tube from the compressor discharge tube to the pilot valve.

The plunger assembly in the main valve can only be shifted by the pressure differential between the high and low sides of the system. The pilot section of the valve opens and closes ports for the small capillary tubes to the main valve to cause it to shift.

Checking the Reversing Valve

NOTE: SYSTEM OPERATING PRESSURES MUST BE NEAR NORMAL BEFORE VALVE CAN SHIFT.

Run the unit in the heating mode then disconnect one of the 24 vac wires at the reversing valve and the valve should shift to cooling mode. If valve does not shift - replace the valve. For a stuck valve diagnosis run in the cooling mode and check the temp difference between the suction line from the evaporator and the common suction line at the compressor, if there is more than a 3 °F difference then change the valve.

Checking The Reversing Valve Solenoid

The solenoid coil is an electromagnetic type coil mounted on the reversing valve and is energized during the operation of the compressor in the heating cycle.

1. Turn off high voltage electrical power to unit.
2. Unplug line voltage lead from reversing valve coil.
3. Check for electrical resistance through the coil. If the coil is open replace the coil.
4. Check from each lead of coil to the copper liquid line as it leaves the unit or the ground lug. There should be no continuity between either of the coil leads and ground; if there is, the coil is grounded and must be replaced.
5. If coil tests okay, reconnect the electrical leads.
6. Make sure coil has been assembled correctly.

NOTE: DO NOT START UNIT WITH SOLENOID COIL REMOVED FROM VALVE, OR DO NOT REMOVE COIL AFTER UNIT IS IN OPERATION. THIS WILL CAUSE THE COIL TO BURN OUT.



WARNING

HIGH VOLTAGE
DISCONNECT ALL POWER BEFORE SERVICING OR INSTALLING THIS UNIT. MULTIPLE POWER SOURCES MAY BE PRESENT. FAILURE TO DO SO MAY CAUSE PROPERTY DAMAGE, PERSONAL INJURY OR DEATH.



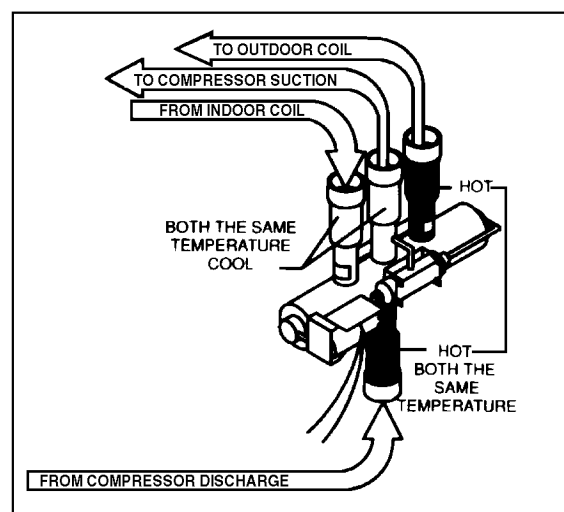
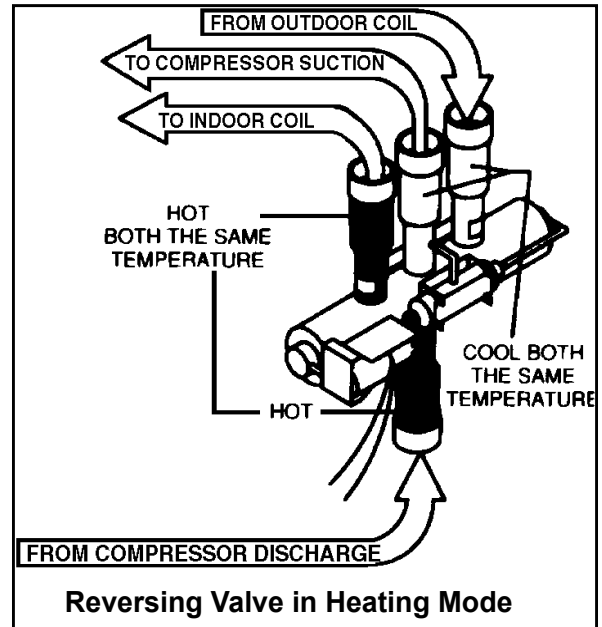

WARNING

HIGH PRESSURE HAZARD
SEALED REFRIGERATION SYSTEM CONTAINS REFRIGERANT AND OIL UNDER HIGH PRESSURE. PROPER SAFETY PROCEDURES MUST BE FOLLOWED, AND PROPER PROTECTIVE CLOTHING MUST BE WORN WHEN WORKING WITH REFRIGERANTS. FAILURE TO FOLLOW THESE PROCEDURES COULD RESULT IN SERIOUS INJURY OR DEATH.



WARNING

ELECTRICAL SHOCK HAZARD
TURN OFF ELECTRIC POWER BEFORE SERVICE OR INSTALLATION.
UNIT MUST BE PROPERLY GROUNDED.
UNIT MUST HAVE CORRECT FUSE OR CIRCUIT BREAKER PROTECTION. UNIT'S SUPPLY CIRCUIT MUST HAVE THE CORRECT WIRE CONDUCTOR SIZE. ALL ELECTRICAL CONNECTIONS AND WIRING MUST BE INSTALLED BY A QUALIFIED ELECTRICIAN AND CONFORM TO THE NATIONAL ELECTRICAL CODE AND ALL LOCAL CODES WHICH HAVE JURISDICTION. FAILURE TO DO SO CAN RESULT IN PROPERTY DAMAGE, PERSONAL INJURY AND/OR DEATH.



WARNING

BURN HAZARD
PROPER SAFETY PROCEDURES MUST BE FOLLOWED, AND PROPER PROTECTIVE CLOTHING MUST BE WORN WHEN WORKING WITH A TORCH.
FAILURE TO FOLLOW THESE PROCEDURES COULD RESULT IN MODERATE OR SERIOUS INJURY.

Locked Rotor Voltage (L.R.V.) Test

Locked rotor voltage (L.R.V.) is the actual voltage available at the compressor under a stalled condition.

Single Phase Connections

Disconnect power from unit. Using a voltmeter, attach one lead of the meter to the run "R" terminal on the compressor and the other lead to the common "C" terminal of the compressor. Restore power to unit.

Determine L.R.V.

Start the compressor with the volt meter attached; then stop the unit. Attempt to restart the compressor within a couple of seconds and immediately read the voltage on the meter. The compressor under these conditions will not start and will usually kick out on overload within a few seconds since the pressures in the system will not have had time to equalize. Voltage should be at or above minimum voltage of 197 VAC, as specified on the rating plate. If less than minimum, check for cause of inadequate power supply; i.e., incorrect wire size, loose electrical connections, etc.

Amperage (R.L.A) Test

The running amperage of the compressor is the most important of these readings. A running amperage higher than that indicated in the performance data indicates that a problem exists mechanically or electrically.

Single Phase Running and L.R.A. Test

NOTE: CONSULT THE SPECIFICATION AND PERFORMANCE SECTION FOR RUNNING AMPERAGE. THE L.R.A. CAN ALSO BE FOUND ON THE RATING PLATE.

Select the proper amperage scale and clamp the meter probe around the wire to the "C" terminal of the compressor. Turn on the unit and read the running amperage on the meter. If the compressor does not start, the reading will indicate the locked rotor amperage (L.R.A.).

Overloads

The compressor is equipped with either an external or internal overload which senses both motor amperage and winding temperature. High motor temperature or amperage heats the overload causing it to open, breaking the common circuit within the compressor. Heat generated within the compressor shell, usually due to cycling of the motor, is slow to dissipate. It may take anywhere from a few minutes to several hours for the overload to reset.

Checking the Overloads

External Overloads VTAC With power off, remove the leads from compressor terminals. If the compressor is hot, allow the overload to cool before starting check. Using an ohmmeter, test continuity across the terminals of the external overload. If you do not have continuity; this indicates that the overload is open and must be replaced.

Internal Overloads VTAC, 18K, and 24k BTUs

The overload is embedded in the motor windings to sense the winding temperature and/or current draw. The overload is connected in series with the common motor terminal. Should the internal temperature and/or current draw become excessive, the contacts in the overload will open, turning off the compressor. The overload will automatically reset, but may require several hours before the heat is dissipated.

Checking the Internal Overload

WARNING: MAKE SURE COMPRESSOR IS COOL TO THE TOUCH PRIOR TO OHMS TESTING.

1. With no power to unit, remove the leads from the compressor terminals.
2. Using an ohmmeter, test continuity between terminals C-S and C-R. If no continuity, the compressor overload is open and the compressor must be replaced.



WARNING

ELECTRICAL SHOCK HAZARD

TURN OFF ELECTRIC POWER BEFORE SERVICE OR INSTALLATION.

UNIT MUST BE PROPERLY GROUNDING.

UNIT MUST HAVE CORRECT FUSE OR CIRCUIT BREAKER PROTECTION. UNIT'S SUPPLY CURCUIT MUST HAVE THE CORRECT WIRE CONDUCTOR SIZE. ALL ELECTRICAL CONNECTIONS AND WIRING MUST BE INSTALLED BY A QUALIFIED ELECTRICIAN AND CONFORM TO THE NATIONAL ELECTRICAL CODE AND ALL LOCAL CODES WHICH HAVE JURISDICTION. FAILURE TO DO SO CAN RESULT IN PROPERTY DAMAGE, PERSONAL INJURY AND/OR DEATH.



WARNING

HIGH PRESSURE HAZARD

SEALED REFRIGERATION SYSTEM CONTAINS REFRIGERANT AND OIL UNDER HIGH PRESSURE.

PROPER SAFETY PROCEDURES MUST BE FOLLOWED, AND PROPER PROTECTIVE CLOTHING MUST BE WORN WHEN WORKING WITH REFRIGERANTS.

FAILURE TO FOLLOW THESE PROCEDURES COULD RESULT IN SERIOUS INJURY OR DEATH.

CHECKING COMPRESSOR EFFICIENCY

The reason for compressor inefficiency is normally due to broken or damaged suction and/or discharge valves, reducing the ability of the compressor to pump refrigerant gas.

NOTE: BEFORE INSTALLING VALVES AND GAUGES, CHECK THE COMPRESSOR DISCHARGE TEMPERATURE AND COMPRESSOR CURRENT, LOW COMPRESSOR AMPERAGE COMBINED WITH LOW DISCHARGE TEMPERATURE IS AN INDICATION THAT THE COMPRESSOR MIGHT BE FAULTY.

This condition can be checked as follows:

1. Install a piercing valve on the suction and discharge or liquid process tube.
2. Attach gauges to the high and low sides of the system.-
3. Start the system and run a "cooling or heating performance test." If test shows:
 - a. Below normal high side pressure
 2. Above normal low side pressure
 3. Low temperature difference across coil

The compressor valves are faulty - replace the compressor.

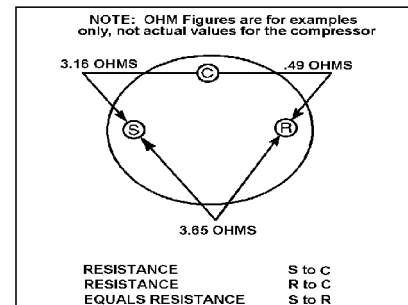

Resistance Chart

Single Phase Resistance Test

Remove the leads from the compressor terminals and set the ohmmeter on the lowest scale (R x 1).

Touch the leads of the ohmmeter from terminals common to start ("C" to "S"). Next, touch the leads of the ohmmeter from terminals common to run ("C" to "R").

Add values "C" to "S" and "C" to "R" together and check resistance from start to run terminals ("S" to "R"). Resistance "S" to "R" should equal the total of "C" to "S" and "C" to "R."

In a single phase PSC compressor motor, the highest value will be from the start to the run connections ("S" to "R"). The next highest resistance is from the start to the common connections ("S" to "C"). The lowest resistance is from the run to common. ("C" to "R") Before replacing a compressor, check to be sure it is defective.

GROUND TEST

Ensure the that compressor wires are disconnected. Use an ohmmeter set on its highest scale. Touch one lead to the copper tubing (clean point of contact as a good connection is a must) and the other probe in turn to each compressor terminal. If a reading is obtained the compressor is grounded and must be replaced. Check the complete electrical system to the compressor and compressor internal electrical system, check to be certain that compressor is not out on internal overload.

Complete evaluation of the system must be made whenever you suspect the compressor is defective. If the compressor has been operating for sometime, a careful examination must be made to determine why the compressor failed.

Many compressor failures are caused by the following conditions:

1. Improper air flow over the evaporator.
2. Overcharged refrigerant system causing liquid to be returned to the compressor.
3. Restricted refrigerant system.
4. Lack of lubrication.
5. Liquid refrigerant returning to compressor causing oil to be washed out of bearings.
6. Non-condensables such as air and moisture in the system. Moisture is extremely destructive to a refrigerant system.
7. Bad run capacitor.

COMPONENT IDENTIFICATION

HEATING ELEMENTS AND LIMIT SWITCHES



WARNING

ELECTRICAL SHOCK HAZARD

TURN OFF ELECTRIC POWER BEFORE SERVICE OR INSTALLATION.

UNIT MUST BE PROPERLY GROUNDED.

UNIT MUST HAVE CORRECT FUSE OR CIRCUIT BREAKER PROTECTION. UNIT'S SUPPLY CURCUIT MUST HAVE THE CORRECT WIRE CONDUCTOR SIZE. ALL ELECTRICAL CONNECTIONS AND WIRING MUST BE INSTALLED BY A QUALIFIED ELECTRICIAN AND CONFORM TO THE NATIONAL ELECTRICAL CODE AND ALL LOCAL CODES WHICH HAVE JURISDICTION. FAILURE TO DO SO CAN RESULT IN PROPERTY DAMAGE, PERSONAL INJURY AND/OR DEATH.



All models are equipped with a dual heating element. Each element has a primary limit switch (bimetal thermostat). Should the blower motor fail, filter become clogged or air-flow be restricted etc., the high limit switch will open and interrupt the power to the heater before reaching an un-safe temperature condition.

The limit switches are in series with the element and will interrupt the power at a designed temperature. (Open at 165° and close at 135°F. Each element is also equipped with a one time switch that will open at 200°F) If this switch opens the heating element module will need to be replaced.

To Check the Heater elements:

1. Open the control box and disconnect the leads from the heater control relays.
2. Ohm out the the elements through the applicable wires.Refer to the specifications chart below and the applicable Wiring Diagram..
3. If you determine the heat element to be out of tolerance (Open, shorted, or out of specifications) access the heater element by remove the left side access panel of the unit (See Heater removal) , remove the wires from the heater element and recheck. If findings are confirmed replace the heater element.

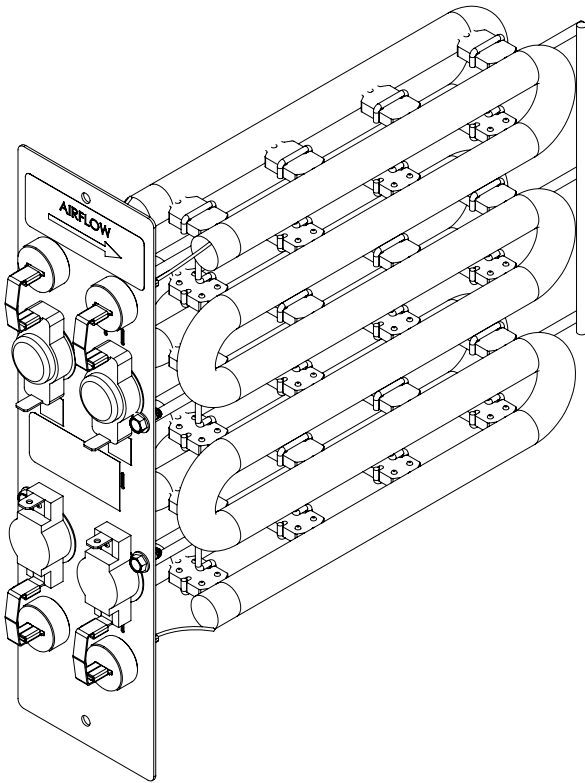

Model	Part Number	Coil 1 (Defrost Coil) Specifications	Coil 2 Specifications	Primary Limit Switch (Auto)	Secondary Limit Switch (1 Time)
230v 2.5kW	8010240	.9 kW 230V 51.70 Ω \pm 5%	1550W 230V 30.02 Ω \pm 5%	OPEN 165 F° CLOSE 135 F°	OPEN 200 F°
230v 3.4kW	8010241	1.55 kW 230V 30.02 Ω \pm 5%	1600W 230V 25.85 Ω \pm 5%		
230v 5kW	8010242	3.4 kW 230V 13.68 Ω \pm 5%	1600W 230V 29.08 Ω \pm 5%		
230v 7.5kW	8010243	5 kW 230V 9.31 Ω \pm 5%	2500W 230V 18.61 Ω \pm 5%		
230v 10kW	8010244	5 kW 230V 9.31 Ω \pm 5%	5000W 230V 9.31 Ω \pm 5%		
265v 2.5kW	8010245	.9 kW 265V 68.63 Ω \pm 5%	1550W 265V 39.85 Ω \pm 5%		
265v 3.4kW	8010246	1.55 kW 265V 39.85 Ω \pm 5%	1800W 265V 34.31 Ω \pm 5%		
265v 5kW	8010247	3.4 kW 265V 18.17 Ω \pm 5%	1600W 265V 38.60 Ω \pm 5%		
265v 7.5kW	8010248	5 kW 265V 12.35 Ω \pm 5%	2500W 265V 24.71 Ω \pm 5%		
265v 10kW	8010249	5 kW 265V 12.35 Ω \pm 5%	5000W 265V 12.35 Ω \pm 5%		

Electrical Heater Coil Specifications

COMPONENT IDENTIFICATION

HEATER ASSEMBLY REMOVAL 9 & 12K

1. Remove right side access panel.
2. Remove heater access panel (3 screws)
3. Disconnect Wiring.
4. Remove 2 screws.
5. Carefully unhook heater assembly from rear hook and slide out of the unit.

**Remove
2 Screws**



COMPONENT IDENTIFICATION

HEATER ASSEMBLY REMOVAL 18 & 24K

1. Remove right side access panel.
2. Disconnect Wiring.
3. Remove 2 screws.
4. Carefully unhook heater assembly from rear hook and slide out of the unit.



Heater Access Panel

**Remove
2 Screws**



COMPONENT IDENTIFICATION

DRAIN PAN VALVE



WARNING

ELECTRICAL SHOCK HAZARD

TURN OFF ELECTRIC POWER BEFORE SERVICE OR INSTALLATION.

UNIT MUST BE PROPERLY GROUNDED.

UNIT MUST HAVE CORRECT FUSE OR CIRCUIT BREAKER PROTECTION. UNIT'S SUPPLY CURCUIT MUST HAVE THE CORRECT WIRE CONDUCTOR SIZE. ALL ELECTRICAL CONNECTIONS AND WIRING MUST BE INSTALLED BY A QUALIFIED ELECTRICIAN AND CONFORM TO THE NATIONAL ELECTRICAL CODE AND ALL LOCAL CODES WHICH HAVE JURISDICTION. FAILURE TO DO SO CAN RESULT IN PROPERTY DAMAGE, PERSONAL INJURY AND/OR DEATH.



Bellows Assembly
Drain Pan Valve

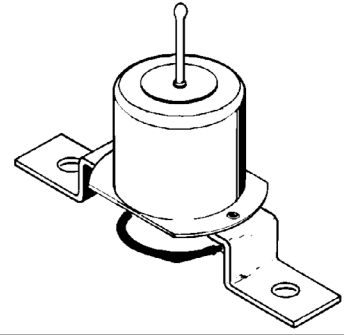

During the cooling mode of operation, condensate which collects in the drain pan is picked up by the condenser fan blade and sprayed onto the condenser coil. This assists in cooling the refrigerant plus evaporating the water.

During the heating mode of operation, it is necessary that water be removed to prevent it from freezing during cold outside temperatures. This could cause the condenser fan blade to freeze in the accumulated water and prevent it from turning.

To provide a means of draining this water, a bellows type drain valve is installed over a drain opening in the base pan.

This valve is temperature sensitive and will open when the outside temperature reaches 40°F. The valve will close gradually as the temperature rises above 40°F to fully close at 60°F.

To test the drain pan valve;

1. Place a pack of ice on the capillary
2. Ensure that the valve opens as it cools down.
3. Remove the pack of ice.
4. Ensure that the valve closes fully as the valve warms back up.

COMPONENT IDENTIFICATION

CHECK EVAPORATOR BLOWER MOTOR AND CONTROL BOARD

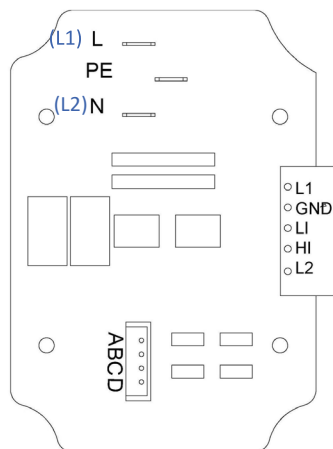
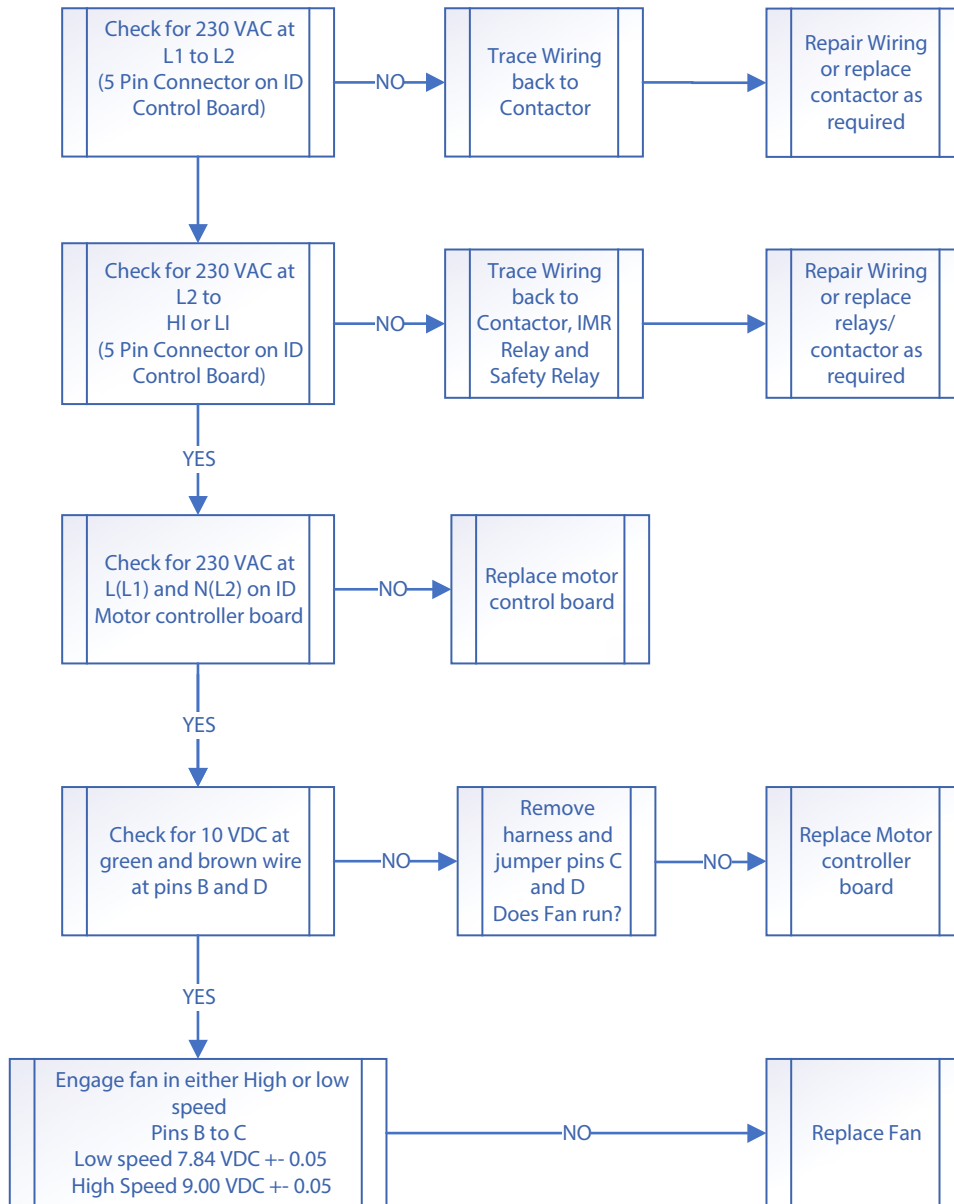

Indoor Blower Motor Testing

COMPONENT IDENTIFICATION

1. Unit needs to be removed from sleeve or closet to facilitate fan replacement. Refer to Chassis Removal
2. Remove electrical box cover.
3. Disconnect the terminals and the P3 cable connector on the indoor fan motor controller.

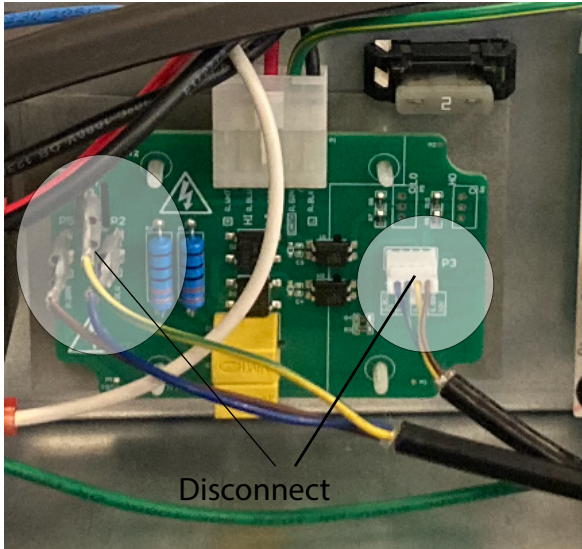

4. Remove right side access panel.
5. Remove 10 fan mounting screws.

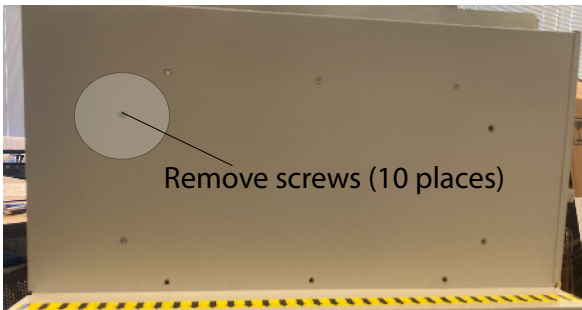

6. Remove four screws on top.



REPLACE EVAPORATOR BLOWER MOTOR (18 & 24K)

7. Remove 3 screws on right side.



8. Move indoor fan support wall back and slide fan out of the right side of the unit.
9. Remove 4 allen screws to separate motor from mount.

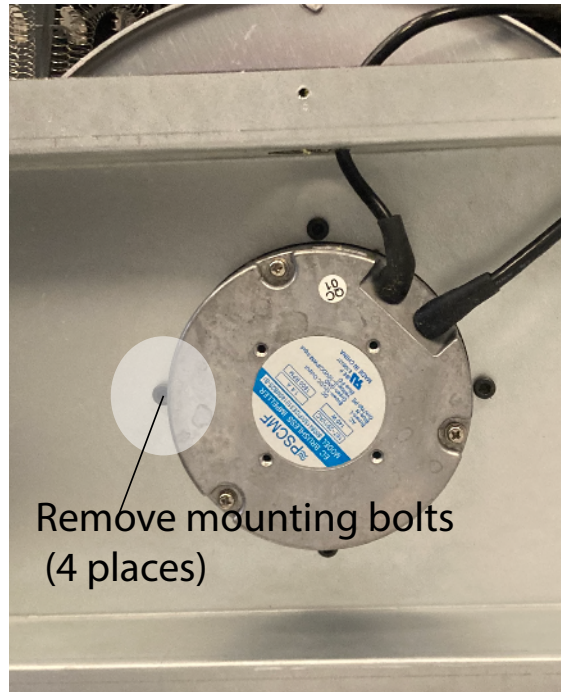

COMPONENT IDENTIFICATION

REPLACE EVAPORATOR BLOWER MOTOR (9 & 12K)

1. Unit needs to be removed from sleeve or closet to facilitate fan replacement. Refer to Chassis Removal
2. Remove electrical box cover.
3. Remove electrical box from unit. (4 screws).
4. Remove blower access cover (3 Screws).
5. Remove excess wire bundle from behind panel.
6. Disconnect the terminals and the P3 cable connector on the indoor fan motor controller.
7. Remove blower access panel.
 - a. Remove 3 screws on the left side
 - b. Remove 2 screws on the right side.
8. Remove 4 allen screws to separate motor from mount.

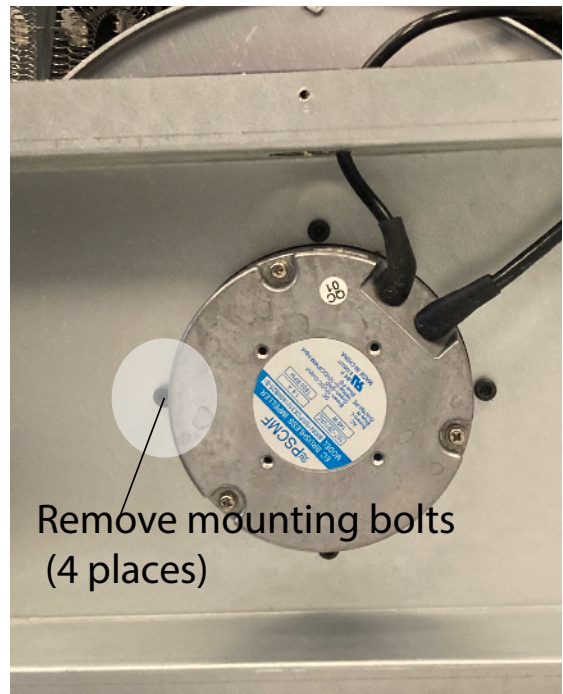
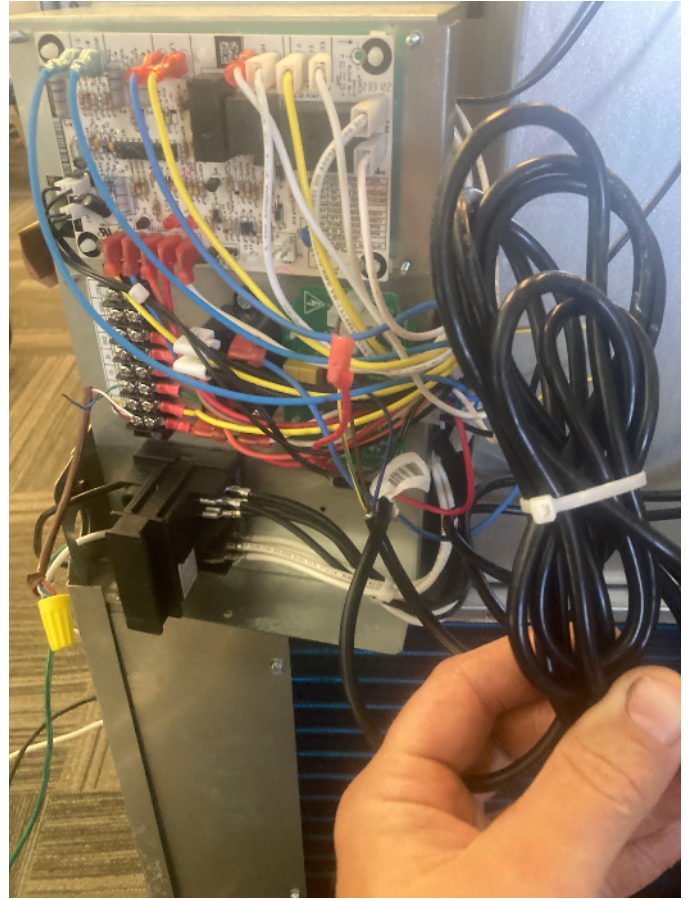

COMPONENT IDENTIFICATION

OUTDOOR FAN CHECK

1. Remove Electrical box cover.
(For 9 and 12 k units remove electrical box cover and gain access to fan relay) Refer to Access Rear Electrical panel to take Electrical Readings.
2. Ensure that unit is running with a demand for outdoor fan.
3. Check for 230/ 265 VAC by placing multimeter probes on Contactor Terminal and fan Out terminal of the defrost control board.
4. If 230/265 VAC is present- remove power from unit and check for loose terminals.
5. Replace motor.

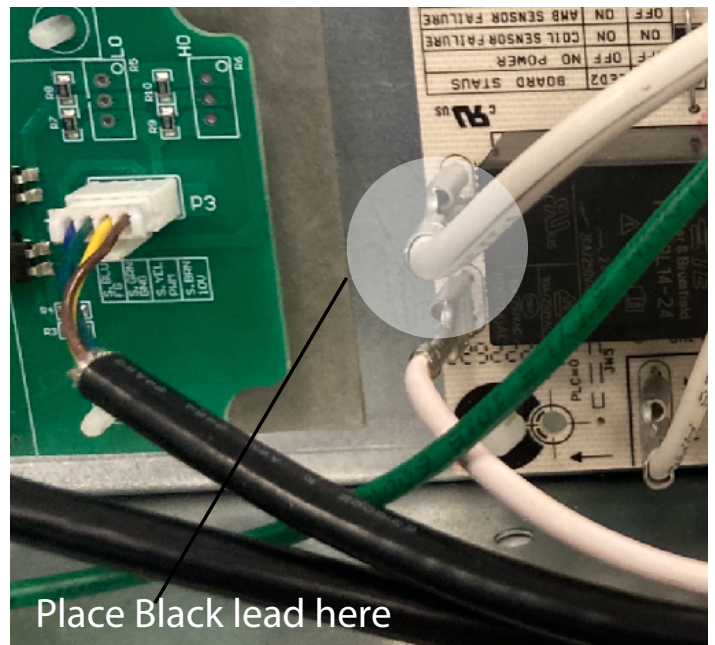
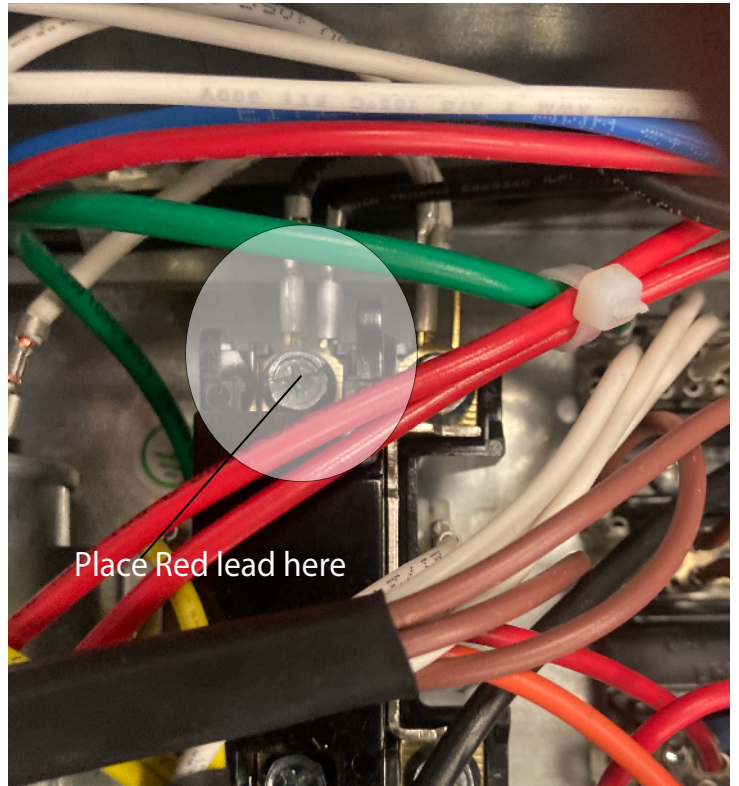

COMPONENT IDENTIFICATION

OUTDOOR FAN REPLACEMENT 9 & 12K

1. Remove chassis from closet. Refer to chassis removal.
2. Remove electrical box.
3. Remove left and right side access panels.
7. Remove 2 screws on each side of shroud.

NOTE: FOR BLADE REPLACEMENT ONLY, DISCONNECTION OF FAN MOTOR WIRES IS NOT REQUIRED

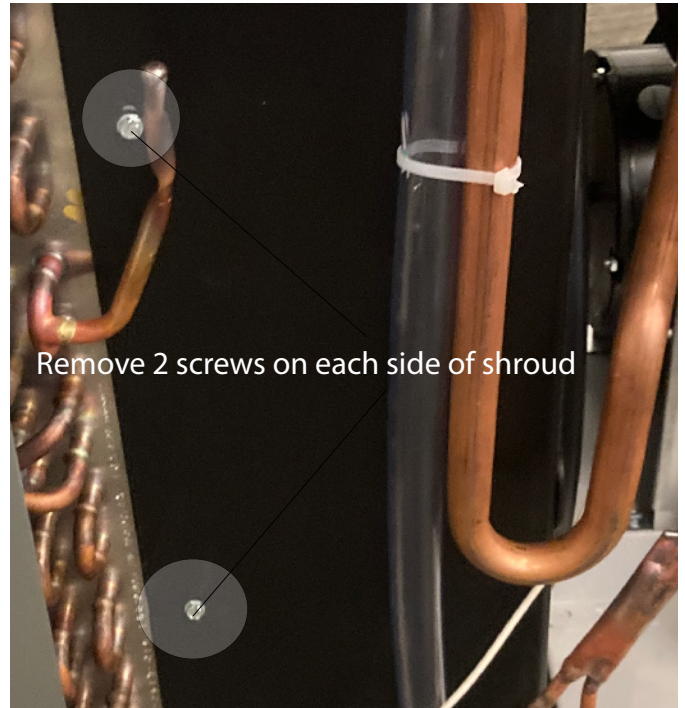
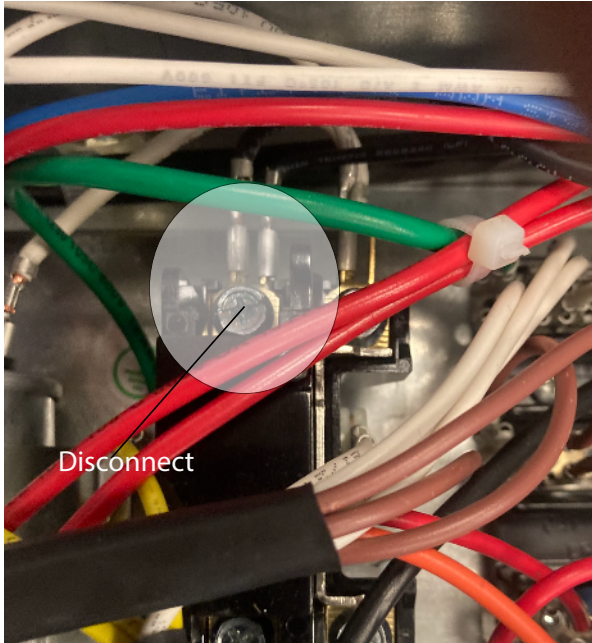

4. Disconnect black red (9k), or blue (12k) wire from T1 of the contactor.
8. Remove 1 screw from bottom of shroud.

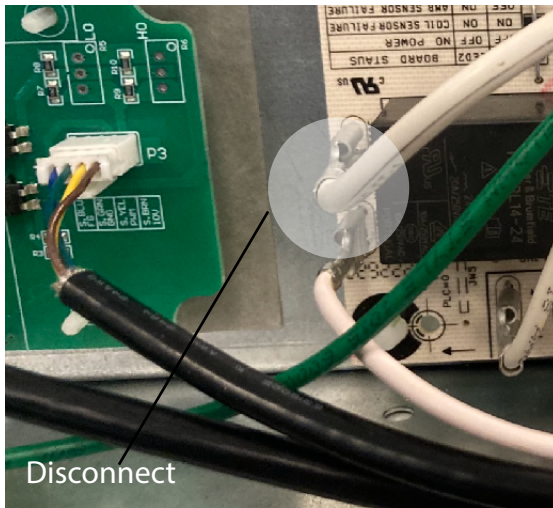

5. Disconnect white wire from fan out terminal of the defrost board .
6. Pull some slack out of white wire in the bundle to facilitate fan removal.



9. Remove 2 screws on rear panel.
10. Remove four fan mounting screws and ground wire

COMPONENT IDENTIFICATION

OUTDOOR FAN REPLACEMENT 9 & 12K

- 11. Mark position of depth on clamp with sharpie for reinstallation.

Loosen clamp and slide blade off fan motor shaft.



- 12. Pull back fan shroud and remove blade for replacement

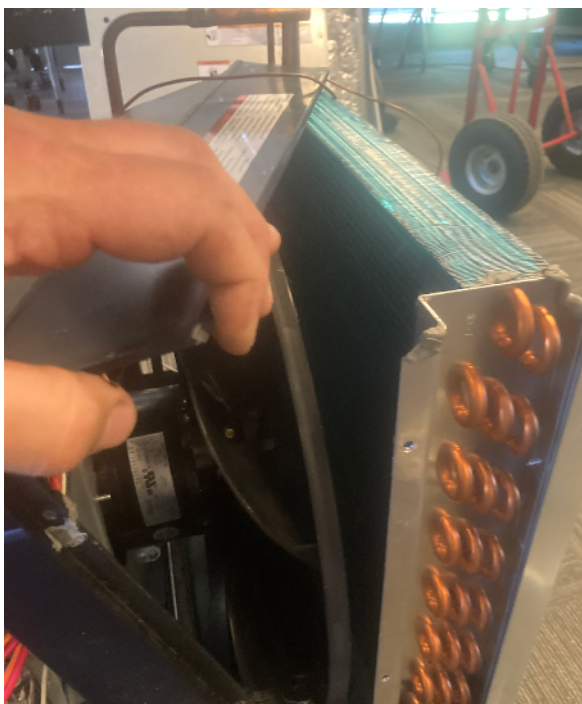

- 13. Remove fan motor mount (6 screws).



- 14. Remove motor from mount (4 screws).



COMPONENT IDENTIFICATION

OUTDOOR FAN REPLACEMENT 18 & 24K

1. Remove chassis from closet. Refer to chassis removal.
2. Remove left and right side lower access panels.

NOTE: FOR BLADE REPLACEMENT ONLY, DISCONNECTION OF FAN MOTOR WIRES IS NOT REQUIRED

3. Disconnect black wire from T1 of the contactor.
4. Disconnect white wire from fan out terminal of the defrost board

6. Pull some slack out of white wire in the bundle to facilitate fan removal.

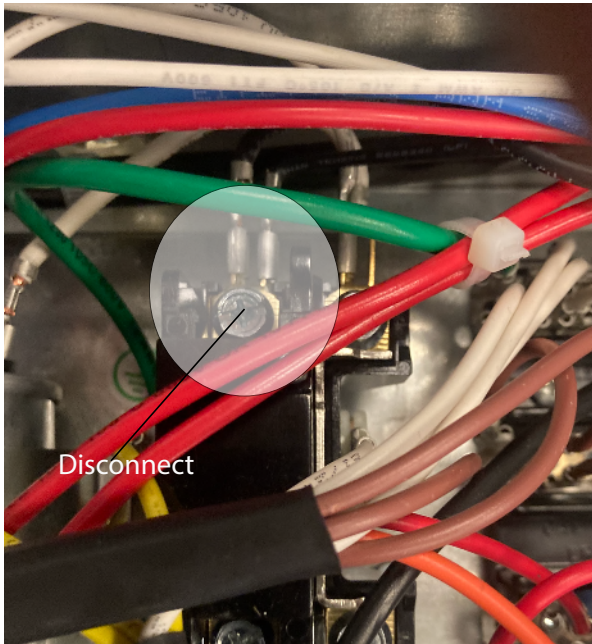

5. Remove sensor from coil.

7. Remove 2 screws on each side of shroud.

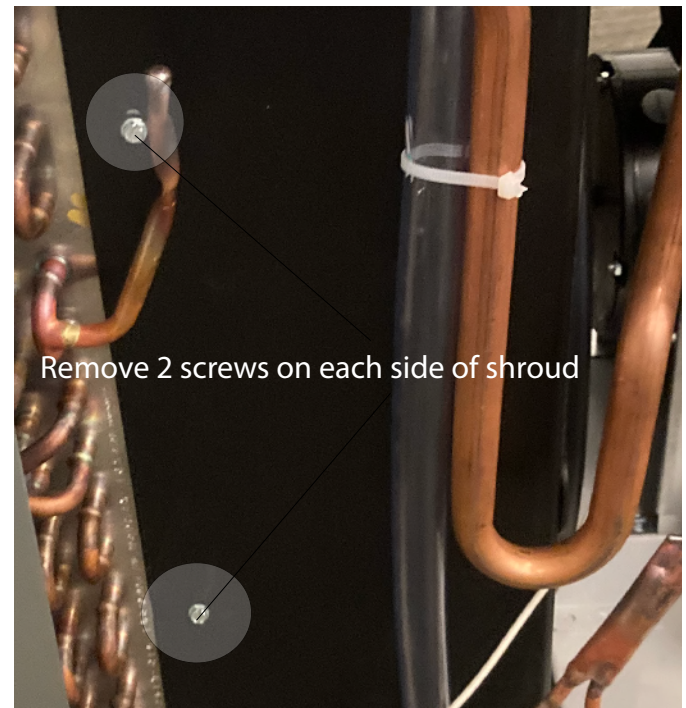
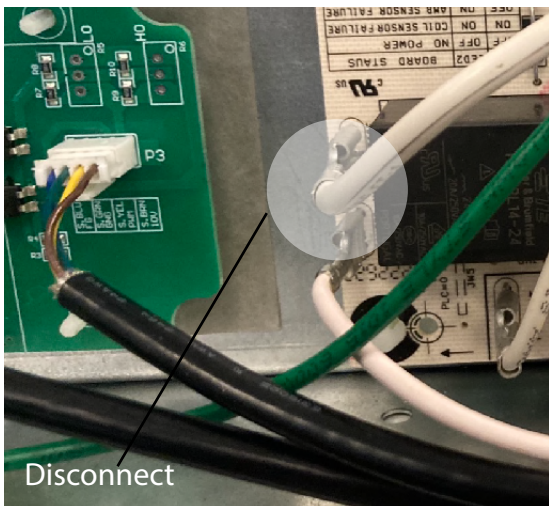

COMPONENT IDENTIFICATION

OUTDOOR FAN REPLACEMENT 18 & 24K

8. Remove 2 screws on rear panel.



9. Remove four fan mounting screws and ground wire.

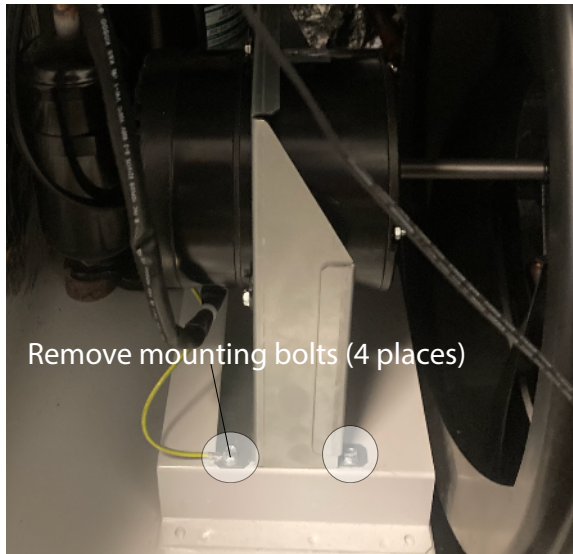

10. Loosen set screw to remove fan blade.



11. Remove 3 screws from fan motor bracket.



COMPONENT IDENTIFICATION

BASEPAN HEATER

To check the basepan heater operation;

1. Access the electrical box
 - a. For the 9 and 12k models refer to this procedure:
Access Electrical box.
2. With Power removed from the unit ohm out the 1 amp in line fuses located behind the electrical box.
 - a. If fuse is open - check the heater element wiring by ohming out the wiring to each side and to ground.
 - b. If no shorts are found - replace fuse and check operation.
 - c. If heater is shorted out - replace basepan heater - contact customer support for assistance.

NOTE: THE DEFROST CONTROL BOARD SENDS 24 VAC FROM PIN D OF THE CONTROL BOARD TO ENERGIZE THE DEFROST HEAT RELAY AND CLOSE CONTACTS TO ONE STRIP OF ELECTRIC HEAT. BASEPAN HEAT IS ALSO PROVIDED AT THIS TIME.

3. Restore Power to the unit.
4. Force the unit into defrost mode:

NOTE: WHEN OPERATING IN THE DEFROST MODE, THE CONTROL WILL HAVE THE COMPRESSOR CONTACTOR, AND AUXILIARY HEAT OUTPUTS ACTIVATED. THE CONDENSER FAN RELAY CONTACTS WILL BE OPEN, DE-ENERGIZING THE FAN MOTOR. THE ACCUMULATED DEFROST TIME IS MONITORED WHILE IN THE DEFROST MODE AND COMPRESSOR IS ENERGIZED. THE LOW PRESSURE SWITCH IS IGNORED DURING DEFROST. WHEN A DEFROST CYCLE HAS BEEN INITIATED, IF THE Y THERMOSTAT INPUT IS REMOVED, THE CURRENT DEFROST CYCLE WILL BE SUSPENDED, BUT THE ACCUMULATED DEFROST TIME IS FROZEN, AND THE CONTROL WILL RESUME DEFROST OPERATION AT THE START OF THE NEXT HEATING CYCLE (Y ACTIVE, B ACTIVE AND COIL TEMPERATURE IS BELOW 35°F) WITH A MINIMUM OF THE ASCD BETWEEN COMPRESSOR ACTIVATIONS.

The accumulated defrost time resumes when the compressor output is re-energized. The defrost relay will de-energize when the Y thermostat input is removed and energize when the Defrost is resumed.

5. Check for 24 vac at the Defrost heat relay. If 24 vac is not available, use wiring diagram to trace back signal through the defrost relay and back to pin C on the defrost control board. Replace parts as required.
6. Check for 230 vac on both sides of the relay to ensure it has properly energized.

R-410A REFRIGERANT SYSTEM REPAIR



WARNING

USE APPROVED STANDARD REFRIGERANT RECOVERING PROCEDURES AND EQUIPMENT TO RELIEVE HIGH PRESSURE BEFORE OPENING SYSTEM FOR REPAIR.

DO NOT ALLOW LIQUID REFRIGERANT TO CONTACT SKIN. DIRECT CONTACT WITH LIQUID REFRIGERANT CAN RESULT IN MINOR TO MODERATE INJURY.

BE EXTREMELY CAREFUL WHEN USING AN OXY-ACETYLENE TORCH. DIRECT CONTACT WITH THE TORCH'S FLAME OR HOT SURFACES CAN CAUSE SERIOUS BURNS.

MAKE CERTAIN TO PROTECT PERSONAL AND SURROUNDING PROPERTY WITH FIRE PROOF MATERIALS AND HAVE A FIRE EXTINGUISHER AT HAND WHILE USING A TORCH.

PROVIDE ADEQUATE VENTILATION TO VENT OFF TOXIC FUMES, AND WORK WITH A QUALIFIED ASSISTANT WHENEVER POSSIBLE. ALWAYS USE A PRESSURE REGULATOR WHEN USING DRY NITROGEN TO TEST THE SEALED REFRIGERATION SYSTEM FOR LEAKS, FLUSHING ETC.



WARNING

HIGH PRESSURE HAZARD
SEALED REFRIGERATION SYSTEM CONTAINS REFRIGERANT AND OIL UNDER HIGH PRESSURE.

PROPER SAFETY PROCEDURES MUST BE FOLLOWED, AND PROPER PROTECTIVE CLOTHING MUST BE WORN WHEN WORKING WITH REFRIGERANTS.

FAILURE TO FOLLOW THESE PROCEDURES COULD RESULT IN SERIOUS INJURY OR DEATH.

The following is a list of important considerations when working with R-410A equipment

1. R-410A pressure is approximately 60% higher than R-22 pressure.
2. R-410A cylinders must not be allowed to exceed 125 F, they may leak or rupture.
3. R-410A must never be pressurized with a mixture of air, it may become flammable.
4. Servicing equipment and components must be specifically designed for use with R-410A and dedicated to prevent contamination.
5. Manifold sets must be equipped with gauges capable of reading 750 psig (high side) and 200 psig (low side), with a 500-psig lowside retard.
6. Gauge hoses must have a minimum 750-psig service pressure rating
7. Recovery cylinders must have a minimum service pressure rating of 400 psig, (DOT 4BA400 and DOT BW400 approved cylinders).
8. POE (Polyol-Ester) lubricants must be used with R-410A equipment.
9. To prevent moisture absorption and lubricant contamination, do not leave the refrigeration system open to the atmosphere longer than 1 hour.



WARNING

EPA 608 WARNING:
IT IS A VIOLATION OF THE ENVIRONMENTAL PROTECTION AGENCY, CLAUSE 608A, TO SERVICE REFRIGERATION SYSTEMS WITHOUT PROPER CERTIFICATION

10. Weigh-in the refrigerant charge into the high side of the system.
11. Introduce liquid refrigerant charge into the high side of the system.
12. For low side pressure charging of R-410A, use a charging adaptor.
13. Use industry standard R-410A filter dryers.

EQUIPMENT REQUIRED:

1. Electrical Multimeter
2. E.P.A. Approved Refrigerant Recovery System
3. Vacuum Pump (capable of 200 microns or less vacuum.)
4. Acetylene torch.
5. Electronic Halogen Leak Detector capable of detecting HFC (Hydrofluorocarbon) refrigerants.
6. R410A Refrigerant Manifold
7. 1/4" Braze-type Access Ports
8. Pinch Tool
9. Digital Refrigerant Scale
10. Vacuum Gauge - (0 - 1000 microns)
11. Facilities for flowing nitrogen through refrigeration tubing during all brazing processes.

EQUIPMENT MUST BE CAPABLE OF:

1. Recovering refrigerant to EPA required levels.
2. Evacuation from both the high side and low side of the system simultaneously.
3. Introducing refrigerant charge into high side of the system.
4. Accurately weighing the refrigerant charge introduced into the system.

R-410A REFRIGERANT SYSTEM REPAIR

REFRIGERANT CHARGING



WARNING

ELECTRICAL SHOCK HAZARD
TURN OFF ELECTRIC POWER BEFORE SERVICE OR INSTALLATION.
UNIT MUST BE PROPERLY GROUNDED.
UNIT MUST HAVE CORRECT FUSE OR CIRCUIT BREAKER PROTECTION. UNIT'S SUPPLY CURCUIT MUST HAVE THE CORRECT WIRE CONDUCTOR SIZE. ALL ELECTRICAL CONNECTIONS AND WIRING MUST BE INSTALLED BY A QUALIFIED ELECTRICIAN AND CONFORM TO THE NATIONAL ELECTRICAL CODE AND ALL LOCAL CODES WHICH HAVE JURISDICTION. FAILURE TO DO SO CAN RESULT IN PROPERTY DAMAGE, PERSONAL INJURY AND/OR DEATH.



WARNING

HIGH PRESSURE HAZARD
SEALED REFRIGERATION SYSTEM CONTAINS REFRIGERANT AND OIL UNDER HIGH PRESSURE.
PROPER SAFETY PROCEDURES MUST BE FOLLOWED, AND PROPER PROTECTIVE CLOTHING MUST BE WORN WHEN WORKING WITH REFRIGERANTS.
FAILURE TO FOLLOW THESE PROCEDURES COULD RESULT IN SERIOUS INJURY OR DEATH.

NOTE: ALWAYS WEIGH IN REFRIGERANT BASED ON THE MODEL NAMEPLATE.

NOTE: BECAUSE THE REFRIGERANT SYSTEM IS A SEALED SYSTEM, SERVICE PROCESS TUBES WILL HAVE TO BE INSTALLED. FIRST INSTALL A LINE TAP AND REMOVE REFRIGERANT FROM SYSTEM. MAKE NECESSARY SEALED SYSTEM REPAIRS AND VACUUM SYSTEM. CRIMP PROCESS TUBE LINE AND SOLDER END SHUT. DO NOT LEAVE A SERVICE VALVE IN THE SEALED SYSTEM.

Proper refrigerant charge is essential to proper unit operation. Operating a unit with an improper refrigerant charge will result in reduced performance (capacity) and/or efficiency. Accordingly, the use of proper charging methods during servicing will insure that the unit is functioning as designed and that its compressor will not be damaged.

NOTE:FACTORY SEALED UNITS WILL NOT BE OVERCHARGED

Too much refrigerant (overcharge) in the system is just as bad (if not worse) than not enough refrigerant (undercharge), they both can be the source of certain compressor failures if they remain uncorrected for any period of time. Quite often, other problems (such as low air flow across evaporator, etc.) are misdiagnosed as refrigerant charge problems. The refrigerant circuit diagnosis chart will assist you in properly diagnosing the systems.

An overcharged unit will return liquid refrigerant (slugging) back to the suction side of the compressor eventually causing a mechanical failure within the compressor. This mechanical failure can manifest itself as valve failure, bearing failure, and/or other mechanical failure. The specific type of failure will be influenced by the amount of liquid being returned, and the length of time the slugging continues.

Not enough refrigerant (undercharge) on the other hand, will cause the temperature of the suction gas to increase to the point where it does not provide sufficient cooling for the compressor motor. When this occurs, the motor winding temperature will increase causing the motor to overheat and possibly cycle open the compressor overload protector. Continued overheating of the motor windings and/or cycling of the overload will eventually lead to compressor motor or overload failure.

R-410A REFRIGERANT SYSTEM REPAIR

SEALED SYSTEM METHOD OF CHARGING/ REPAIRS



WARNING

BURN HAZARD

PROPER SAFETY PROCEDURES MUST BE FOLLOWED, AND PROPER PROTECTIVE CLOTHING MUST BE WORN WHEN WORKING WITH A TORCH.

FAILURE TO FOLLOW THESE PROCEDURES COULD RESULT IN MODERATE OR SERIOUS INJURY.



WARNING

FREEZE HAZARD

PROPER SAFETY PROCEDURES MUST BE FOLLOWED, AND PROPER PROTECTIVE CLOTHING MUST BE WORN WHEN WORKING WITH A TORCH.

FAILURE TO FOLLOW THESE PROCEDURES COULD RESULT IN MINOR OR MODERATE INJURY.

The refrigerant cycle is critically charged. The only acceptable method for charging the sealed system is the Weighed in Charge Method.

The weighed in method should always be used whenever a charge is removed from a unit such as for a leak repair, compressor replacement, or when there is no refrigerant charge left in the unit. To charge by this method, requires the following steps:

1. Install a piercing valve to remove refrigerant from the sealed system. (Piercing valve must be removed from the system before recharging.)
2. Recover Refrigerant in accordance with EPA regulations.
3. Install a process tube to the sealed system.
4. Make necessary repairs to system.
5. Evacuate the system to 1500 microns
6. Repressurize to 500 PSI with nitrogen
7. Evacuate the system to 1000 microns
8. Repressurize to 500 PSI with nitrogen
9. Evacuate the system to below 500 microns
10. Weigh in the refrigerant charge with the property quantity of R-410A refrigerant per model nameplate.
11. Start unit, and verify performance.
12. Crimp the process tube and solder the end shut.

R-410A REFRIGERANT SYSTEM REPAIR

UNDERCHARGED REFRIGERANT SYSTEM



WARNING

ELECTRICAL SHOCK HAZARD

TURN OFF ELECTRIC POWER BEFORE SERVICE OR INSTALLATION.

UNIT MUST BE PROPERLY GROUNDED.

UNIT MUST HAVE CORRECT FUSE OR CIRCUIT BREAKER PROTECTION. UNIT'S SUPPLY CURCUIT MUST HAVE THE CORRECT WIRE CONDUCTOR SIZE. ALL ELECTRICAL CONNECTIONS AND WIRING MUST BE INSTALLED BY A QUALIFIED ELECTRICIAN AND CONFORM TO THE NATIONAL ELECTRICAL CODE AND ALL LOCAL CODES WHICH HAVE JURISDICTION. FAILURE TO DO SO CAN RESULT IN PROPERTY DAMAGE, PERSONAL INJURY AND/OR DEATH.



NOTE: ENSURE FAN IS ON HIGH SPEED DURING TESTING.

An undercharged system will result in poor performance (low pressures, etc.) in both the heating and cooling cycle.

Whenever you service a unit with an undercharge of refrigerant, always suspect a leak. The leak must be repaired before charging the unit.

To check for an undercharged system, turn the unit on, allow the compressor to run long enough to establish working pressures in the system (15 to 20 minutes).

During the cooling cycle you can listen carefully at the exit of the metering device into the evaporator; an intermittent hissing and gurgling sound indicates a low refrigerant charge. Intermittent frosting and thawing of the evaporator is another indication of a low charge, however, frosting and thawing can also be caused by insufficient air over the evaporator or partial restriction in the refrigeration system besides the metering device.

Checks for an undercharged system can be made at the compressor. If the compressor seems quieter than normal, it is an indication of a low refrigerant charge.

If the compressor reads low amperage and has a high discharge line temperature at the compressor, it is an indication of low system refrigerant.

A check of the amperage drawn by the compressor motor should show a lower reading. (Check the Unit Specification.) After the unit has run 10 to 15 minutes, check the gauge pressures. Gauges connected to system with an undercharge will have low head pressures and substantially low suction pressures.



WARNING

HIGH PRESSURE HAZARD

SEALED REFRIGERATION SYSTEM CONTAINS REFRIGERANT AND OIL UNDER HIGH PRESSURE.

PROPER SAFETY PROCEDURES MUST BE FOLLOWED, AND PROPER PROTECTIVE CLOTHING MUST BE WORN WHEN WORKING WITH REFRIGERANTS.

FAILURE TO FOLLOW THESE PROCEDURES COULD RESULT IN SERIOUS INJURY OR DEATH.

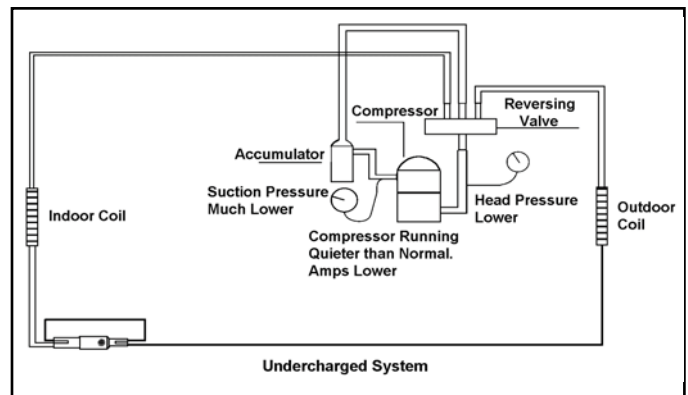

R-410A REFRIGERANT SYSTEM REPAIR

OVERCHARGED REFRIGERANT SYSTEMS



WARNING

ELECTRICAL SHOCK HAZARD

TURN OFF ELECTRIC POWER BEFORE SERVICE OR INSTALLATION.

UNIT MUST BE PROPERLY GROUNDED.

UNIT MUST HAVE CORRECT FUSE OR CIRCUIT BREAKER PROTECTION. UNIT'S SUPPLY CIRCUIT MUST HAVE THE CORRECT WIRE CONDUCTOR SIZE. ALL ELECTRICAL CONNECTIONS AND WIRING MUST BE INSTALLED BY A QUALIFIED ELECTRICIAN AND CONFORM TO THE NATIONAL ELECTRICAL CODE AND ALL LOCAL CODES WHICH HAVE JURISDICTION. FAILURE TO DO SO CAN RESULT IN PROPERTY DAMAGE, PERSONAL INJURY AND/OR DEATH.



WARNING

HIGH PRESSURE HAZARD

SEALED REFRIGERATION SYSTEM CONTAINS REFRIGERANT AND OIL UNDER HIGH PRESSURE.

PROPER SAFETY PROCEDURES MUST BE FOLLOWED, AND PROPER PROTECTIVE CLOTHING MUST BE WORN WHEN WORKING WITH REFRIGERANTS.

FAILURE TO FOLLOW THESE PROCEDURES COULD RESULT IN SERIOUS INJURY OR DEATH.

NOTE: ENSURE FAN IS ON HIGH SPEED DURING TESTING.

NOTE: A UNIT SEALED FROM THE FACTORY WILL NOT BE OVERCHARGED.

Whenever an overcharged system is indicated, always make sure that the problem is not caused by air flow problems. Improper air flow over the evaporator coil may indicate some of the same symptoms as an over charged system.

An overcharge can cause the compressor to fail, since it would be "slugged" with liquid refrigerant.

The charge for any system is critical. When the compressor is noisy, suspect an overcharge, when you are sure that the air quantity over the evaporator coil is correct. Icing of the evaporator will not be encountered because the refrigerant will boil later if at all. Gauges connected to system will usually have higher head pressure (depending upon amount of over charge). Suction pressure should be slightly higher.

Compressor amps will be near normal or higher. Noncondensables can also cause these symptoms. To confirm, reclaim some of the charge, if conditions improve, system may be overcharged. If conditions don't improve, Noncondensables are indicated.

R-410A REFRIGERANT SYSTEM REPAIR

RESTRICTED REFRIGERANT SYSTEM

NOTE: Ensure fan is on high speed during testing. Troubleshooting a restricted refrigerant system can be difficult. The following procedures are the more common problems and solutions to these problems. There are two types of refrigerant restrictions: Partial restrictions and complete restrictions.

A partial restriction allows some of the refrigerant to circulate through the system.

With a complete restriction there is no circulation of refrigerant in the system. Restricted refrigerant systems display the same symptoms as a "low-charge condition."

A quick check for either condition begins at the evaporator. With a partial restriction, there may be gurgling sounds at the metering device entrance to the evaporator. The evaporator in a partial restriction could be partially frosted or have an ice ball close to the entrance of the metering device. Frost may continue on the suction line back to the compressor.

Often a partial restriction of any type can be found by feel, as there is a temperature difference from one side of the restriction to the other. There will usually be a difference felt at the capillary tube. This does not indicate a restricted condition.

With a complete restriction, there will be no sound at the metering device entrance. An amperage check of the compressor with a partial restriction may show normal current when compared to the unit specification. With a complete restriction the current drawn may be considerably less than normal, as the compressor is running in a deep vacuum (no load.) Much of the area of the condenser will be relatively cool since most or all of the liquid refrigerant will be stored there.



Make all checks possible before tapping into the system and installing gauges.

When the unit is shut off, or the compressor disengages, the gauges may equalize very slowly.

The above conditions are based primarily on a system in the cooling mode.

R-410A REFRIGERANT SYSTEM REPAIR

COMPRESSOR REPLACEMENT

 WARNING	
<p>ELECTRICAL SHOCK HAZARD TURN OFF ELECTRIC POWER BEFORE SERVICE OR INSTALLATION. UNIT MUST BE PROPERLY GROUNDED. UNIT MUST HAVE CORRECT FUSE OR CIRCUIT BREAKER PROTECTION. UNIT'S SUPPLY CURCUIT MUST HAVE THE CORRECT WIRE CONDUCTOR SIZE. ALL ELECTRICAL CONNECTIONS AND WIRING MUST BE INSTALLED BY A QUALIFIED ELECTRICIAN AND CONFORM TO THE NATIONAL ELECTRICAL CODE AND ALL LOCAL CODES WHICH HAVE JURISDICTION. FAILURE TO DO SO CAN RESULT IN PROPERTY DAMAGE, PERSONAL INJURY AND/OR DEATH.</p>	

 WARNING
<p>HIGH PRESSURE HAZARD SEALED REFRIGERATION SYSTEM CONTAINS REFRIGERANT AND OIL UNDER HIGH PRESSURE. PROPER SAFETY PROCEDURES MUST BE FOLLOWED, AND PROPER PROTECTIVE CLOTHING MUST BE WORN WHEN WORKING WITH REFRIGERANTS. FAILURE TO FOLLOW THESE PROCEDURES COULD RESULT IN SERIOUS INJURY OR DEATH.</p>

 WARNING
<p>EXPLOSION HAZARD THE USE OF NITROGEN REQUIRES A PRESSURE REGULATOR. FOLLOW ALL SAFETY PROCEDURES AND WEAR PROTECTIVE SAFETY CLOTHING ETC. FAILURE TO FOLLOW PROPER SAFETY PROCEDURES COULD RESULT IN SERIOUS INJURY OR DEATH.</p>

 WARNING
<p>FREEZE HAZARD PROPER SAFETY PROCEDURES MUST BE FOLLOWED, AND PROPER PROTECTIVE CLOTHING MUST BE WORN WHEN WORKING WITH A TORCH. FAILURE TO FOLLOW THESE PROCEDURES COULD RESULT IN MINOR OR MODERATE INJURY.</p>

 WARNING
<p>NEVER, UNDER ANY CIRCUMSTANCES, LIQUID CHARGE A ROTARY-COMPRESSOR THROUGH THE LOW SIDE. DOING SO WOULD CAUSE PERMANENT DAMAGE TO THE NEW COMPRESSOR. USE A CHARGING ADAPTER.</p>

1. Be certain to perform all necessary electrical and refrigeration tests to be sure the compressor is actually defective before replacing.
2. Recover all refrigerant from the system through the process tubes.

PROPER HANDLING OF RECOVERED REFRIGERANT ACCORDING TO EPA REGULATIONS IS REQUIRED.

Do not use gauge manifold for this purpose if there has been a burnout. You will contaminate your manifold and hoses. Use a Schrader valve adapter and copper tubing for burnout failures.

3. After all refrigerant has been recovered, disconnect suction and discharge lines from the compressor and remove compressor. Be certain to have both suction and discharge process tubes open to atmosphere.
4. Carefully pour a small amount of oil from the suction stub of the defective compressor into a clean container.
5. Using an acid test kit (one shot or conventional kit), test the oil for acid content according to the instructions with the kit.
6. If any evidence of a burnout is found, no matter how slight, the system will need to be cleaned up following proper procedures.
7. Install the replacement compressor.

CAUTION: WHILE THE UNIT IS BEING EVACUATED, SEAL ALL OPENINGS ON THE DEFECTIVE COMPRESSOR. DO NOT DISTORT THE MANUFACTURERS TUBE CONNECTIONS.

8. Pressurize with trace amounts of R-410A and nitrogen to 550 psi and leak test all connections with a leak detector. Repair any leaks found.
 - 8a. If leak detector is unavailable remove all refrigerant from system and pressurize with nitrogen to 550 psi. Check that system holds pressure. Repeat Step 8 to ensure no more leaks are present
9. Evacuate the system with a good vacuum pump capable of a final vacuum of 300 microns or less. The system should be evacuated through both liquid line and suction line gauge ports.
 - 9a. Evacuate the system to 1500 microns.
 - 9b. Repressurize to 50 PSI with nitrogen.
 - 9c. Evacuate the system to 1000 microns.
 - 9d. Repressurize to 50 PSI with nitrogen.
 - 9e. Evacuate the system to below 500 microns.
10. Weigh in the refrigerant charge with the proper quantity of R-410A liquid refrigerant using digital scale per model nameplate.
11. Start unit, and verify performance.
12. Crimp the process tube and solder the end shut.

R-410A REFRIGERANT SYSTEM REPAIR

COMPRESSOR REPLACEMENT-SPECIAL PROCEDURE IN CASE OF COMPRESSOR BURNOUT



WARNING

ELECTRICAL SHOCK HAZARD

TURN OFF ELECTRIC POWER BEFORE SERVICE OR INSTALLATION.

UNIT MUST BE PROPERLY GROUNDED.

UNIT MUST HAVE CORRECT FUSE OR CIRCUIT BREAKER PROTECTION. UNIT'S SUPPLY CURCUIT MUST HAVE THE CORRECT WIRE CONDUCTOR SIZE. ALL ELECTRICAL CONNECTIONS AND WIRING MUST BE INSTALLED BY A QUALIFIED ELECTRICIAN AND CONFORM TO THE NATIONAL ELECTRICAL CODE AND ALL LOCAL CODES WHICH HAVE JURISDICTION. FAILURE TO DO SO CAN RESULT IN PROPERTY DAMAGE, PERSONAL INJURY AND/OR DEATH.



WARNING

HIGH PRESSURE HAZARD

SEALED REFRIGERATION SYSTEM CONTAINS REFRIGERANT AND OIL UNDER HIGH PRESSURE.

PROPER SAFETY PROCEDURES MUST BE FOLLOWED, AND PROPER PROTECTIVE CLOTHING MUST BE WORN WHEN WORKING WITH REFRIGERANTS.

FAILURE TO FOLLOW THESE PROCEDURES COULD RESULT IN SERIOUS INJURY OR DEATH.



WARNING

EXPLOSION HAZARD

THE USE OF NITROGEN REQUIRES A PRESSURE REGULATOR. FOLLOW ALL SAFETY PROCEDURES AND WEAR PROTECTIVE SAFETY CLOTHING ETC.

FAILURE TO FOLLOW PROPER SAFETY PROCEDURES COULD RESULT IN SERIOUS INJURY OR DEATH.



WARNING

FREEZE HAZARD

PROPER SAFETY PROCEDURES MUST BE FOLLOWED, AND PROPER PROTECTIVE CLOTHING MUST BE WORN WHEN WORKING WITH A TORCH.

FAILURE TO FOLLOW THESE PROCEDURES COULD RESULT IN MINOR OR MODERATE INJURY.



WARNING

NEVER, UNDER ANY CIRCUMSTANCES, LIQUID CHARGE A ROTARY-COMPRESSOR THROUGH THE LOW SIDE. DOING SO WOULD CAUSE PERMANENT DAMAGE TO THE NEW COMPRESSOR. USE A CHARGING ADAPTER.

1. Recover all refrigerant and oil from the system.
2. Remove compressor and TXV from the system.
3. Flush evaporator condenser and all connecting tubing with dry nitrogen or equivalent. Use approved flushing agent to remove all contamination from system. Inspect suction and discharge line for carbon deposits. Remove and clean if necessary. Ensure all acid is neutralized.
4. Reassemble the system, including new drier strainer and TXV.
5. Pressurize with trace amounts of R-410A and nitrogen to 550 psi and leak test all connections with a leak detector. Repair any leaks found.
 - 5a. If leak detector is unavailable remove all refrigerant from system and pressurize with nitrogen to 550 psi. Check that system holds pressure.

Repeat Step 5 to insure no more leaks are present.

NOTE: WHILE THE UNIT IS BEING EVACUATED, SEAL ALL OPENINGS ON THE DEFECTIVE COMPRESSOR. DO NOT DISTORT THE MANUFACTURERS TUBE CONNECTIONS.

6. Evacuate the system with a good vacuum pump capable of a final vacuum of 300 microns or less. The system should be evacuated through both liquid line and suction line gauge ports.
 - 6a. Evacuate the system to 1500 microns.
 - 6b. Repressurize to 50 PSI with nitrogen.
 - 6c. Evacuate the system to 1000 microns.
 - 6d. Repressurize to 50 PSI with nitrogen.
 - 6e. Evacuate the system to below 500 microns.
7. Recharge the system with the correct amount of liquid refrigerant. The proper refrigerant charge will be found on the unit rating plate. The use of an accurate measuring device, such as a charging cylinder, electronic scales or similar device is necessary.

R-410A REFRIGERANT SYSTEM REPAIR

REPLACE THE REVERSING VALVE



WARNING

HIGH PRESSURE HAZARD

SEALED REFRIGERATION SYSTEM CONTAINS REFRIGERANT AND OIL UNDER HIGH PRESSURE.

PROPER SAFETY PROCEDURES MUST BE FOLLOWED, AND PROPER PROTECTIVE CLOTHING MUST BE WORN WHEN WORKING WITH REFRIGERANTS.

FAILURE TO FOLLOW THESE PROCEDURES COULD RESULT IN SERIOUS INJURY OR DEATH.

1. Install Process Tubes. Recover refrigerant from sealed system. PROPER HANDLING OF RECOVERED REFRIGERANT ACCORDING TO EPA REGULATIONS IS REQUIRED.
2. Remove solenoid coil from reversing valve. If coil is to be reused, remove solenoid and protect from heat while changing valve.
3. Unbrazed all lines from reversing valve. (Flow nitrogen during the unbrazing process)
4. Clean all excess braze from all tubing so that they will slip into fittings on new valve.
5. Remove solenoid coil from new valve.
6. Protect new valve body from heat while brazing with plastic heat sink (Thermo Trap) or wrap valve body with wet rag.
7. Fit all lines into new valve and braze lines into new valve.



WARNING

EXPLOSION HAZARD

THE USE OF NITROGEN REQUIRES A PRESSURE REGULATOR. FOLLOW ALL SAFETY PROCEDURES AND WEAR PROTECTIVE SAFETY CLOTHING ETC.

FAILURE TO FOLLOW PROPER SAFETY PROCEDURES COULD RESULT IN SERIOUS INJURY OR DEATH.

8. Pressurize sealed system with trace amounts of R-410A and nitrogen up to 550 psi. Perform Triple evacuation, Refer to Sealed system method of charging. Leak check the system, using a suitable leak detector according to HVAC industry standards.
9. Once the sealed system is leak free, install solenoid coil on new valve and charge the sealed system by weighing in the proper amount and type of refrigerant as shown on rating plate. Crimp the process tubes and solder the ends shut. Do not leave Schrader or piercing valves in the sealed system.

NOTE: WHEN BRAZING A REVERSING VALVE INTO THE SYSTEM, IT IS OF EXTREME IMPORTANCE THAT THE TEMPERATURE OF THE VALVE DOES NOT EXCEED 250°F AT ANY TIME.



NOTICE

FIRE HAZARD

THE USE OF A TORCH REQUIRES EXTREME CARE AND PROPER JUDGMENT. FOLLOW ALL SAFETY RECOMMENDED PRECAUTIONS AND PROTECT SURROUNDING AREAS WITH FIRE PROOF MATERIALS. HAVE A FIRE EXTINGUISHER READILY AVAILABLE. FAILURE TO FOLLOW THIS NOTICE COULD RESULT IN MODERATE TO SERIOUS PROPERTY DAMAGE.

Wrap the reversing valve with a large rag saturated with water. "Re-wet" the rag and thoroughly cool the valve after each brazing operation of the four joints involved.

The wet rag around the reversing valve will eliminate conduction of heat to the valve body when brazing the line connection.

R-410A REFRIGERANT SYSTEM REPAIR

TXV REPLACEMENT



WARNING

HIGH PRESSURE HAZARD

SEALED REFRIGERATION SYSTEM CONTAINS REFRIGERANT AND OIL UNDER HIGH PRESSURE.

PROPER SAFETY PROCEDURES MUST BE FOLLOWED, AND PROPER PROTECTIVE CLOTHING MUST BE WORN WHEN WORKING WITH REFRIGERANTS.

FAILURE TO FOLLOW THESE PROCEDURES COULD RESULT IN SERIOUS INJURY OR DEATH.



NOTICE

FIRE HAZARD

THE USE OF A TORCH REQUIRES EXTREME CARE AND PROPER JUDGMENT. FOLLOW ALL SAFETY RECOMMENDED PRECAUTIONS AND PROTECT SURROUNDING AREAS WITH FIRE PROOF MATERIALS. HAVE A FIRE EXTINGUISHER READILY AVAILABLE. FAILURE TO FOLLOW THIS NOTICE COULD RESULT IN MODERATE TO SERIOUS PROPERTY DAMAGE.



WARNING

EXPLOSION HAZARD

THE USE OF NITROGEN REQUIRES A PRESSURE REGULATOR. FOLLOW ALL SAFETY PROCEDURES AND WEAR PROTECTIVE SAFETY CLOTHING ETC.

FAILURE TO FOLLOW PROPER SAFETY PROCEDURES COULD RESULT IN SERIOUS INJURY OR DEATH.

Please follow the steps below when replacing TXV:

1. Disassemble the front panel.
2. Remove the thermal bulb by undoing the insulation around it.

NOTE: Recover refrigerant from unit.

3. Remove the TXV from the liquid pipe with a welding torch. Be careful not to burn the liquid pipe. (Flow nitrogen during the unbrazing process).
4. Wrap the new TXV with a piece of wet cloth to prevent damage caused by heat from being too hot and connect the nitrogen flow to the liquid pipe to prevent it from being oxidized. Weld the TXV to the liquid pipe, (solder must be 5% or more silver content) and pay attention to the direction of the TXV, then weld the pressure pipe to the gas pipe.
5. When the repair has cooled, pressure test with 550 psi nitrogen, repair any leaks and Evacuate to hold at 300 microns and recharge to name plate quantity.
6. Secure the thermal bulb to the suction pipe with insulation strips.
7. Evacuate the system and charge. Refer to refrigeration charging.

Sensing Bulb

TXV



WARNING

HIGH VOLTAGE!

DISCONNECT ALL POWER BEFORE SERVICING OR INSTALLING THIS UNIT.
MULTIPLE POWER SOURCES MAY BE PRESENT. FAILURE TO DO SO MAY
CAUSE PROPERTY DAMAGE, PERSONAL INJURY OR DEATH.

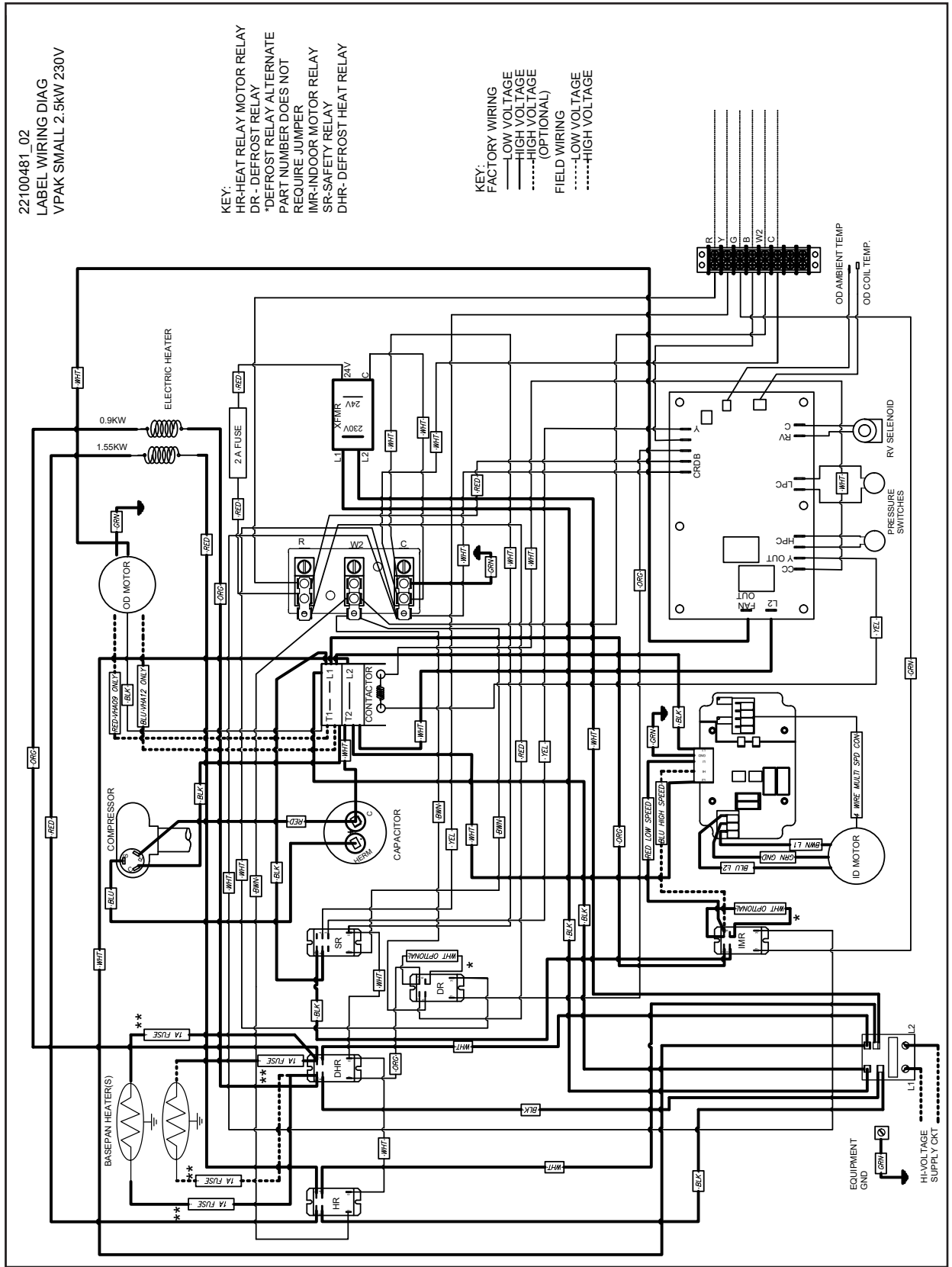

Wiring is subject to change. Always refer to the wiring diagram on the unit for the most up-to-date wiring.

WARNING

HIGH VOLTAGE!

DISCONNECT ALL POWER BEFORE SERVICING OR INSTALLING THIS UNIT.
MULTIPLE POWER SOURCES MAY BE PRESENT. FAILURE TO DO SO MAY
CAUSE PROPERTY DAMAGE, PERSONAL INJURY OR DEATH.

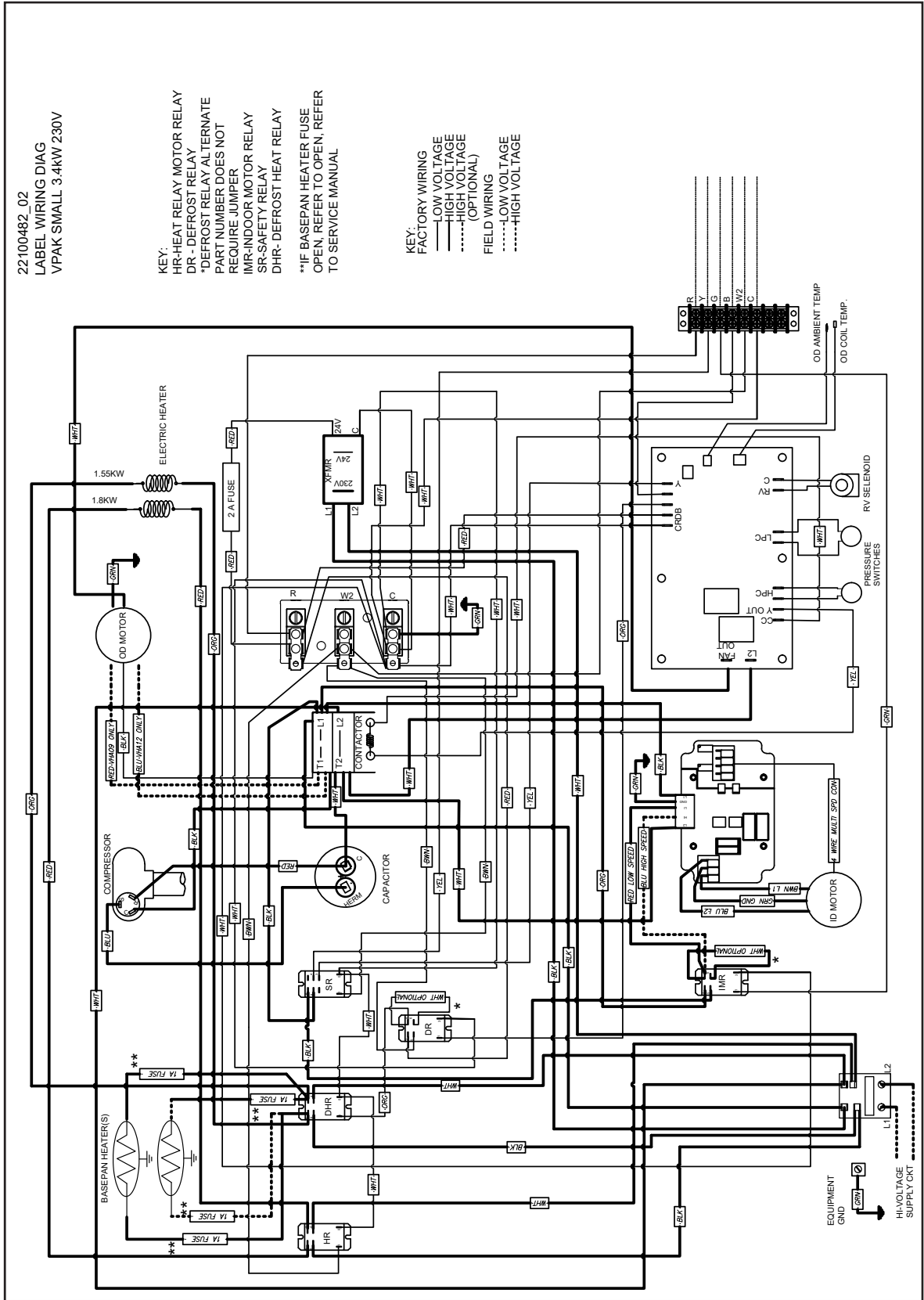

Wiring is subject to change. Always refer to the wiring diagram on the unit for the most up-to-date wiring.



WARNING
HIGH VOLTAGE!
 DISCONNECT ALL POWER BEFORE SERVICING OR INSTALLING THIS UNIT.
 MULTIPLE POWER SOURCES MAY BE PRESENT. FAILURE TO DO SO MAY
 CAUSE PROPERTY DAMAGE, PERSONAL INJURY OR DEATH.

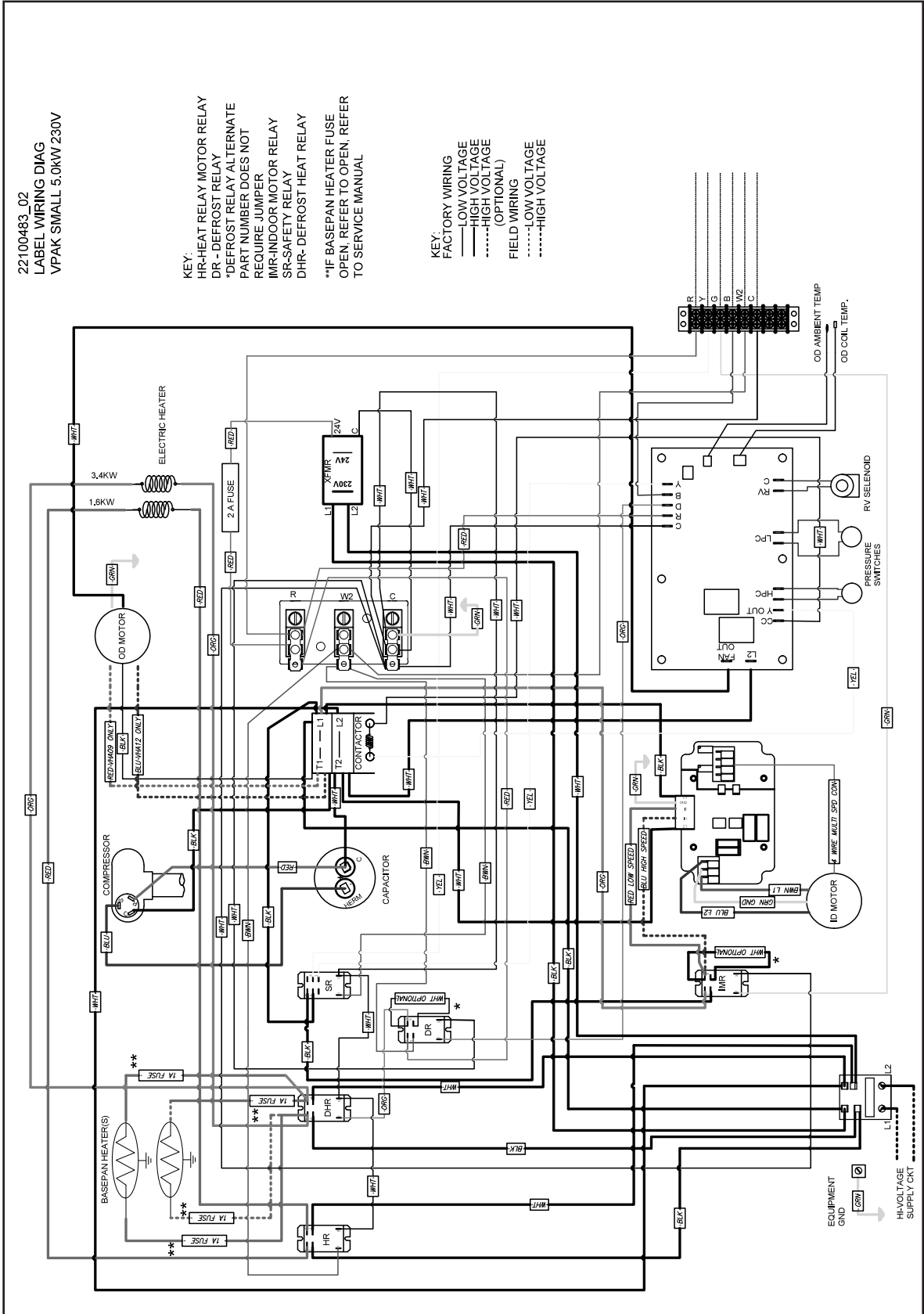

Wiring is subject to change. Always refer to the wiring diagram on the unit for the most up-to-date wiring.



WARNING
HIGH VOLTAGE!
 DISCONNECT ALL POWER BEFORE SERVICING OR INSTALLING THIS UNIT.
 MULTIPLE POWER SOURCES MAY BE PRESENT. FAILURE TO DO SO MAY
 CAUSE PROPERTY DAMAGE, PERSONAL INJURY OR DEATH.

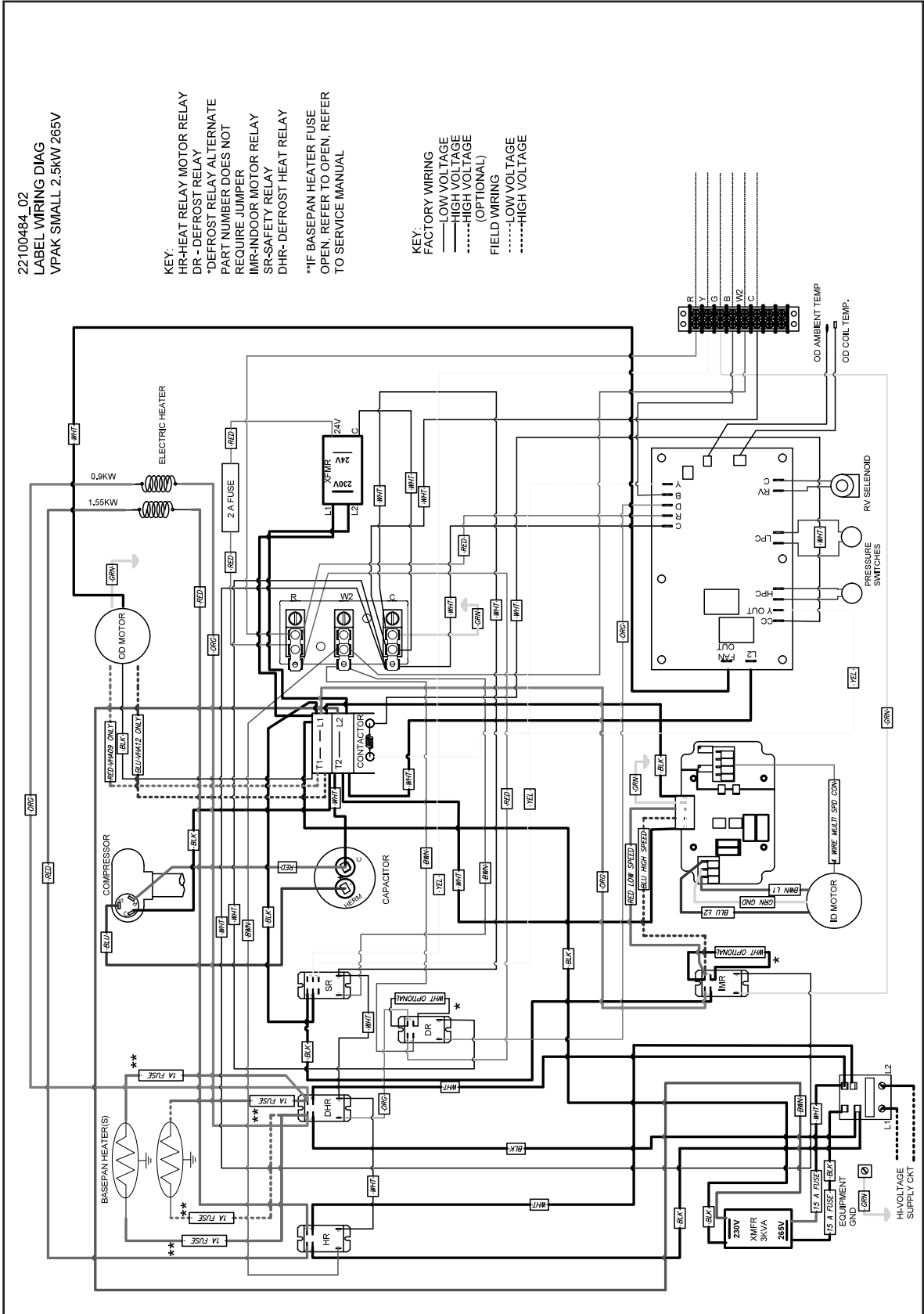

Wiring is subject to change. Always refer to the wiring diagram on the unit for the most up-to-date wiring.



WARNING
HIGH VOLTAGE!
 DISCONNECT ALL POWER BEFORE SERVICING OR INSTALLING THIS UNIT.
 MULTIPLE POWER SOURCES MAY BE PRESENT. FAILURE TO DO SO MAY
 CAUSE PROPERTY DAMAGE, PERSONAL INJURY OR DEATH.

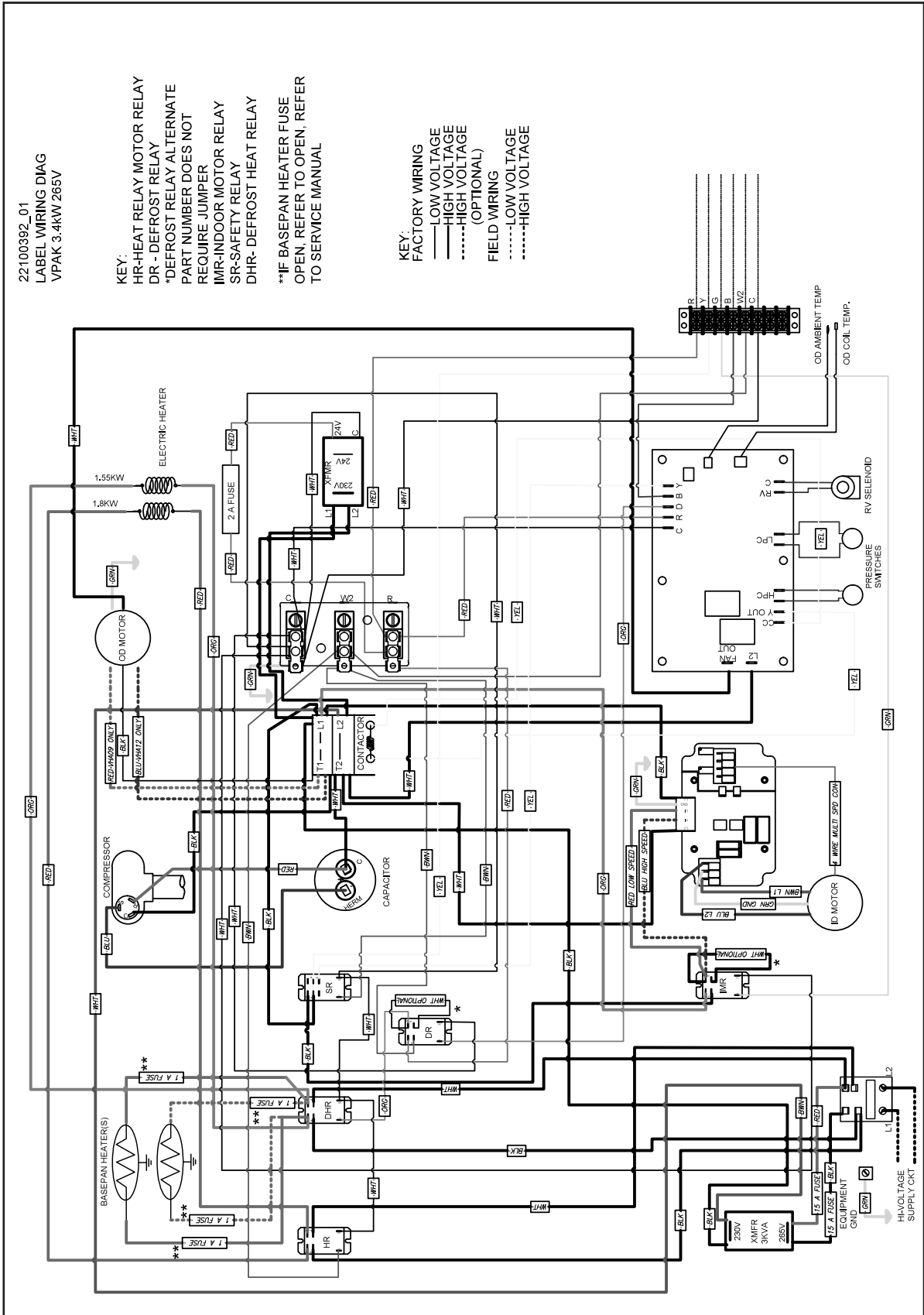

Wiring is subject to change. Always refer to the wiring diagram on the unit for the most up-to-date wiring.



WARNING
HIGH VOLTAGE!
 DISCONNECT ALL POWER BEFORE SERVICING OR INSTALLING THIS UNIT.
 MULTIPLE POWER SOURCES MAY BE PRESENT. FAILURE TO DO SO MAY
 CAUSE PROPERTY DAMAGE, PERSONAL INJURY OR DEATH.

22100486_02
 LABEL WIRING DIAG
 VPAK SMALL 5.0KW 265V

KEY:
 HR-HEAT RELAY MOTOR RELAY
 DR-DEFROST RELAY
 *DEFROST RELAY ALTERNATE
 PART NUMBER DOES NOT
 REQUIRE JUMPER
 IMR-INDOOR MOTOR RELAY
 SR-SAFETY RELAY
 DHR-DEFROST HEAT RELAY
 **IF BASEPAN HEATER FUSE
 OPEN, REFER TO OPEN, REFER
 TO SERVICE MANUAL

KEY:
 FACTORY WIRING
 ——— LOW VOLTAGE
 ——— HIGH VOLTAGE
 - - - - - (OPTIONAL)
 FIELD WIRING
 - - - - - LOW VOLTAGE
 - - - - - HIGH VOLTAGE

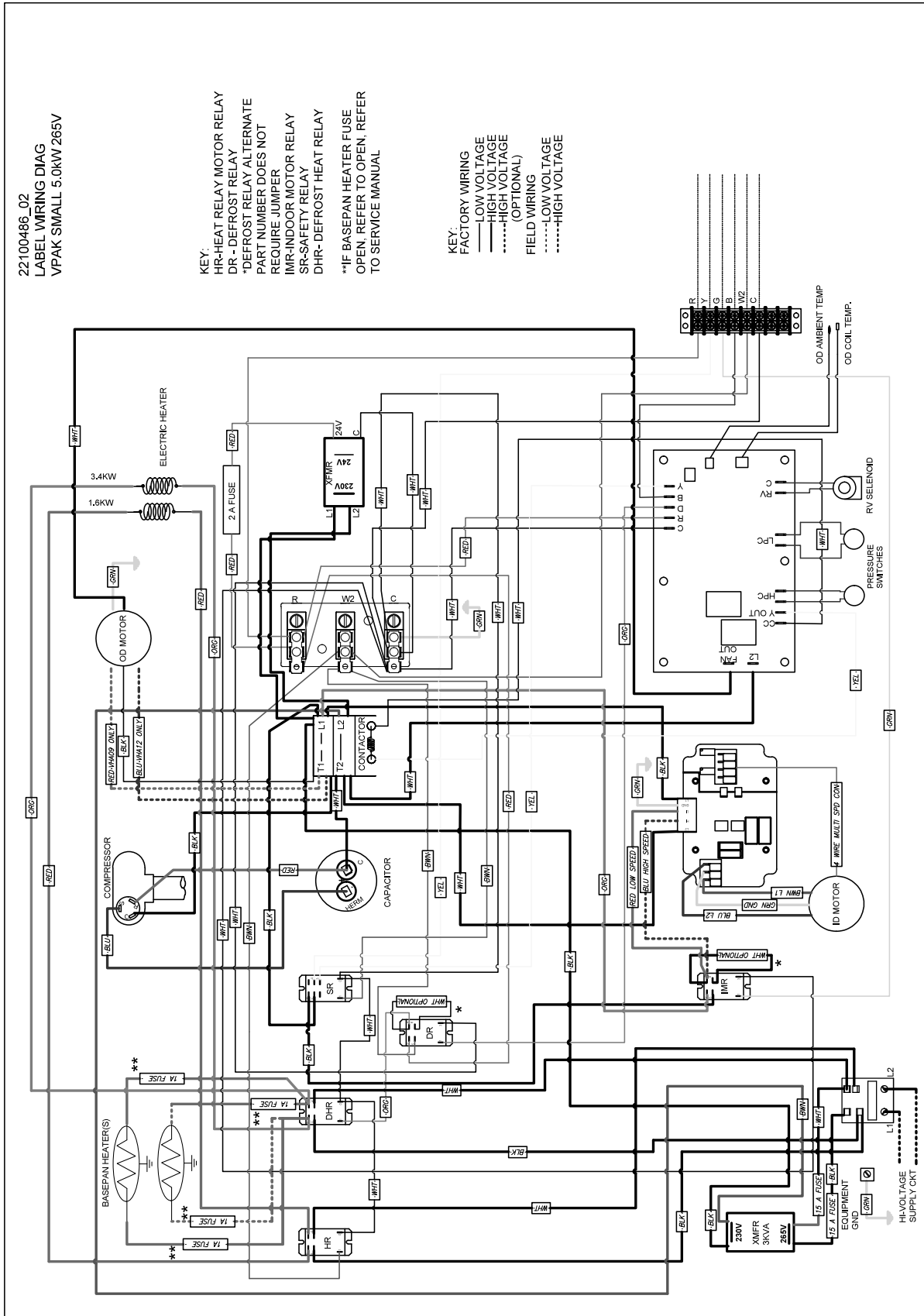

Wiring is subject to change. Always refer to the wiring diagram on the unit for the most up-to-date wiring.



WARNING
HIGH VOLTAGE!
 DISCONNECT ALL POWER BEFORE SERVICING OR INSTALLING THIS UNIT.
 MULTIPLE POWER SOURCES MAY BE PRESENT. FAILURE TO DO SO MAY
 CAUSE PROPERTY DAMAGE, PERSONAL INJURY OR DEATH.

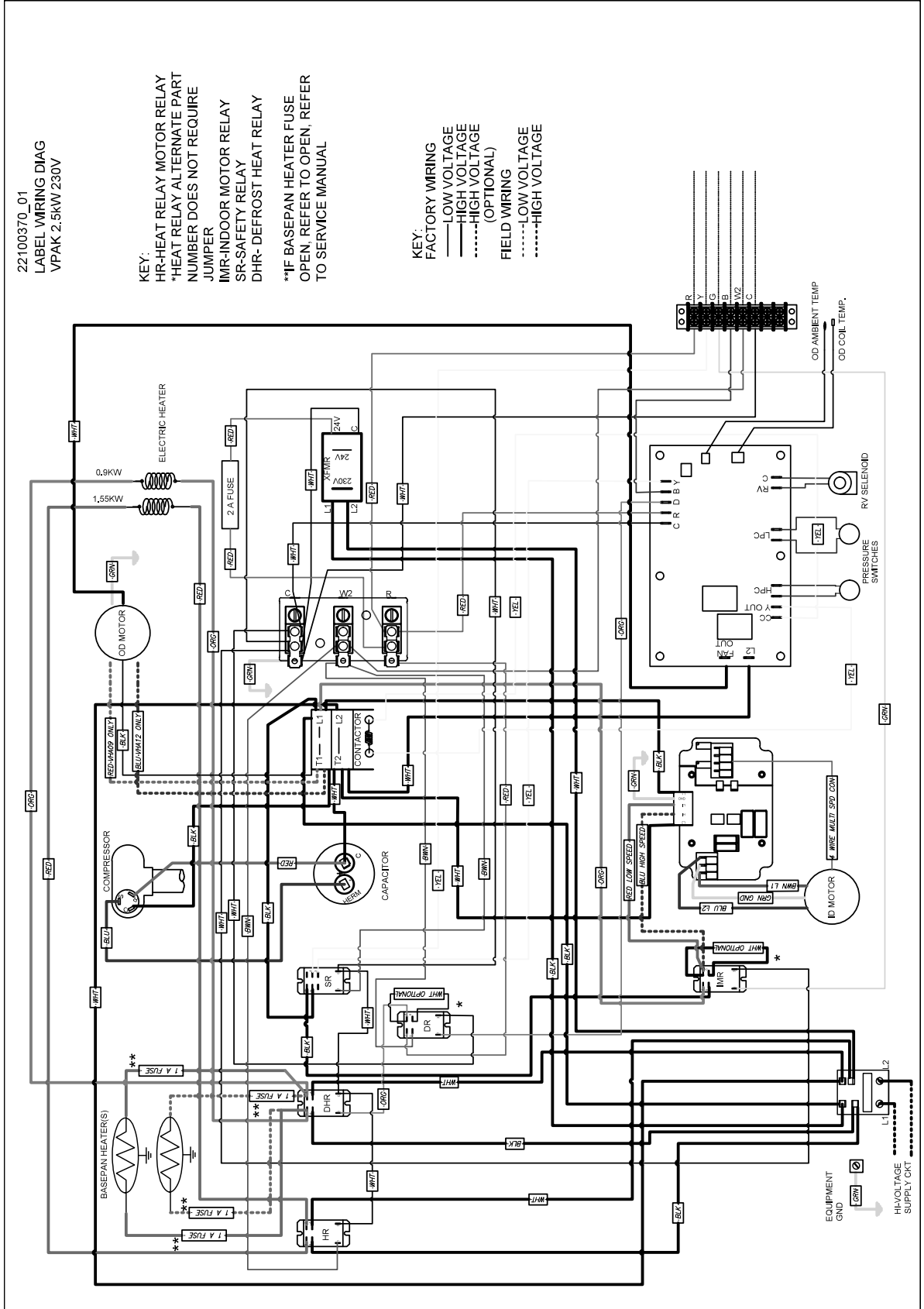

Wiring is subject to change. Always refer to the wiring diagram on the unit for the most up-to-date wiring.



WARNING
HIGH VOLTAGE!
 DISCONNECT ALL POWER BEFORE SERVICING OR INSTALLING THIS UNIT.
 MULTIPLE POWER SOURCES MAY BE PRESENT. FAILURE TO DO SO MAY
 CAUSE PROPERTY DAMAGE, PERSONAL INJURY OR DEATH.

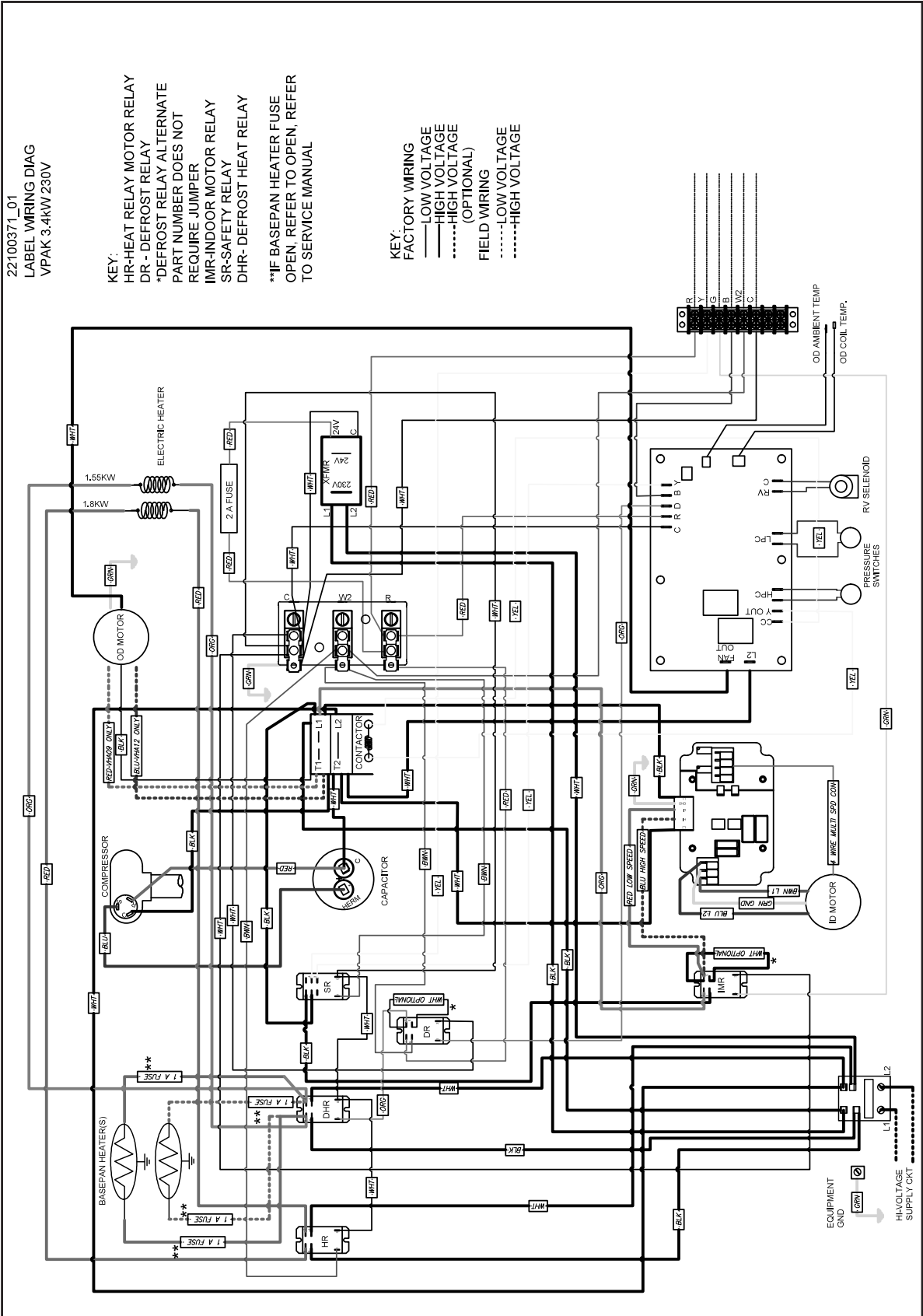

Wiring is subject to change. Always refer to the wiring diagram on the unit for the most up-to-date wiring.

WARNING

HIGH VOLTAGE!

DISCONNECT ALL POWER BEFORE SERVICING OR INSTALLING THIS UNIT.
MULTIPLE POWER SOURCES MAY BE PRESENT. FAILURE TO DO SO MAY
CAUSE PROPERTY DAMAGE, PERSONAL INJURY OR DEATH.

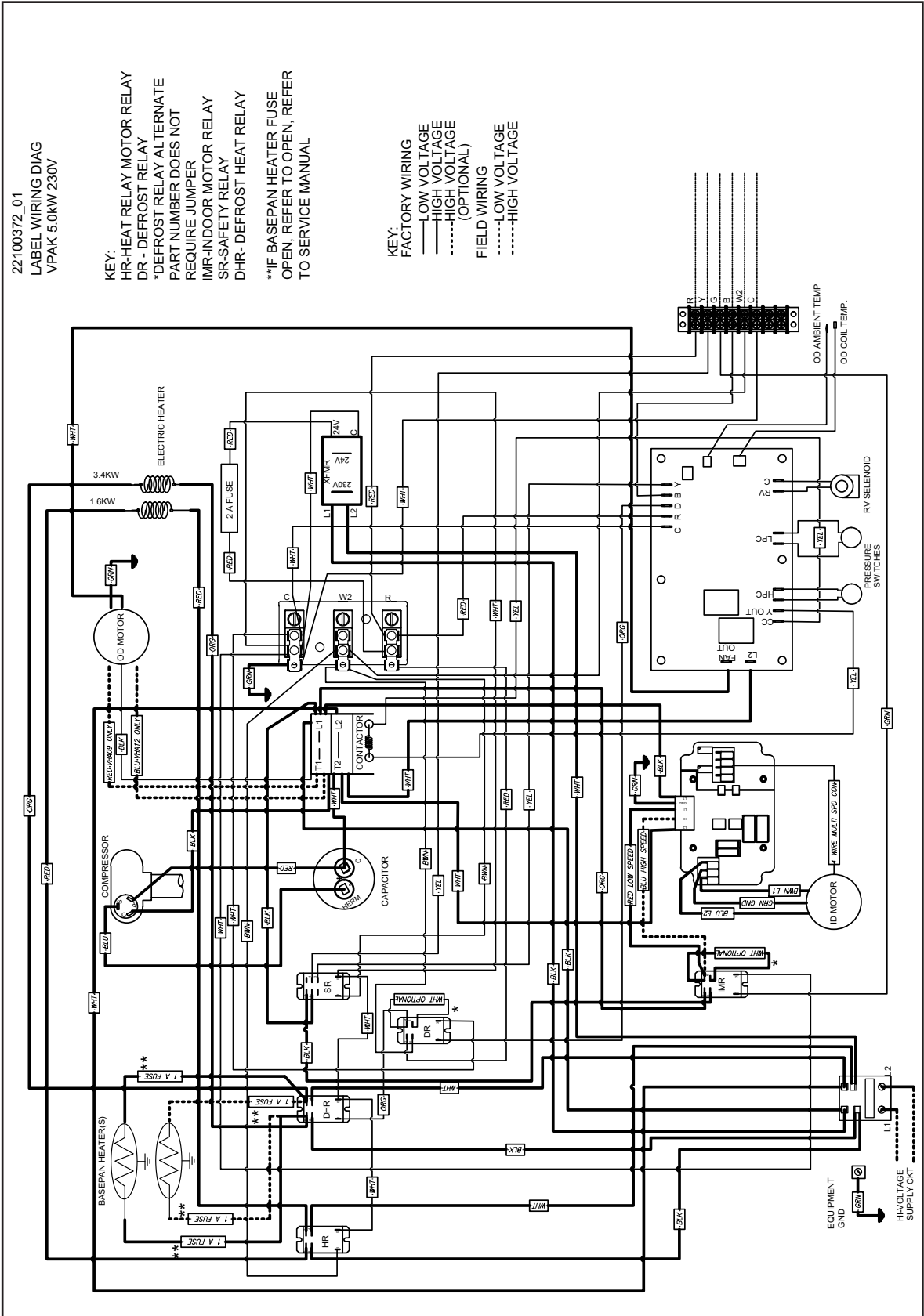

Wiring is subject to change. Always refer to the wiring diagram on the unit for the most up-to-date wiring.

WARNING

HIGH VOLTAGE!

DISCONNECT ALL POWER BEFORE SERVICING OR INSTALLING THIS UNIT.
MULTIPLE POWER SOURCES MAY BE PRESENT. FAILURE TO DO SO MAY
CAUSE PROPERTY DAMAGE, PERSONAL INJURY OR DEATH.

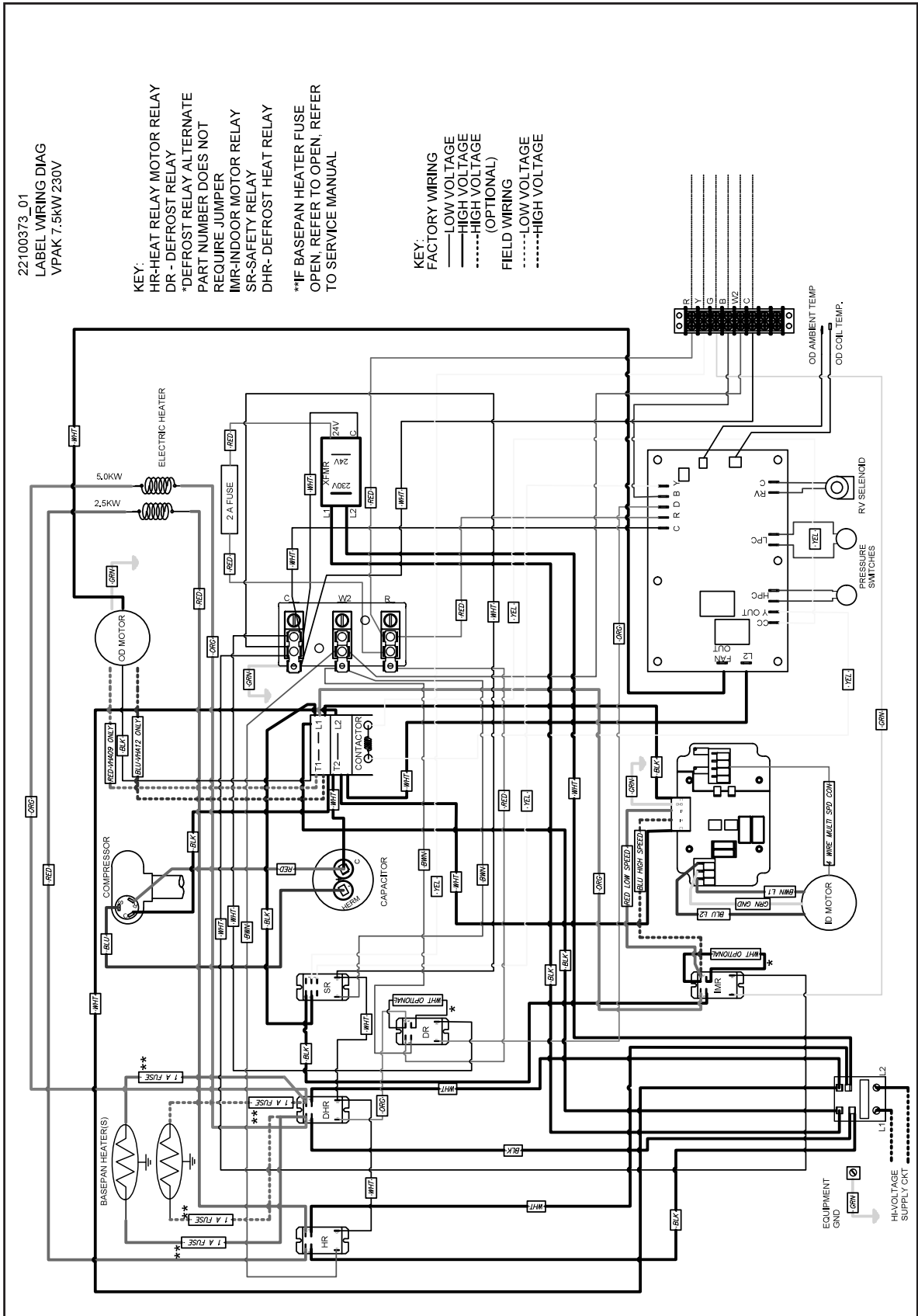

Wiring is subject to change. Always refer to the wiring diagram on the unit for the most up-to-date wiring.



WARNING

HIGH VOLTAGE!
DISCONNECT ALL POWER BEFORE SERVICING OR INSTALLING THIS UNIT.
MULTIPLE POWER SOURCES MAY BE PRESENT. FAILURE TO DO SO MAY
CAUSE PROPERTY DAMAGE, PERSONAL INJURY OR DEATH.

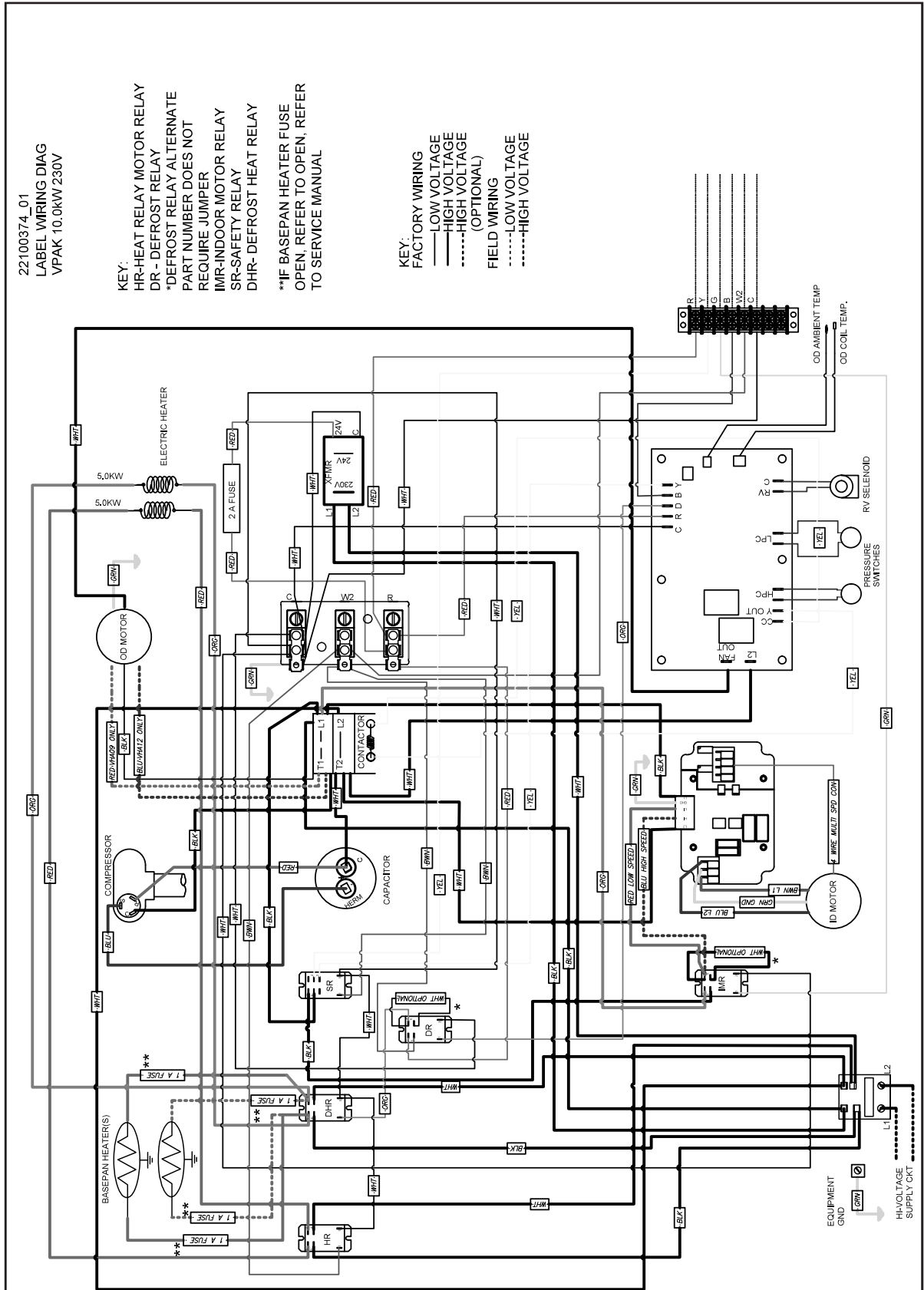

Wiring is subject to change. Always refer to the wiring diagram on the unit for the most up-to-date wiring.



HIGH VOLTAGE!
DISCONNECT ALL POWER BEFORE SERVICING OR INSTALLING THIS UNIT.
MULTIPLE POWER SOURCES MAY BE PRESENT. FAILURE TO DO SO MAY
CAUSE PROPERTY DAMAGE, PERSONAL INJURY OR DEATH.

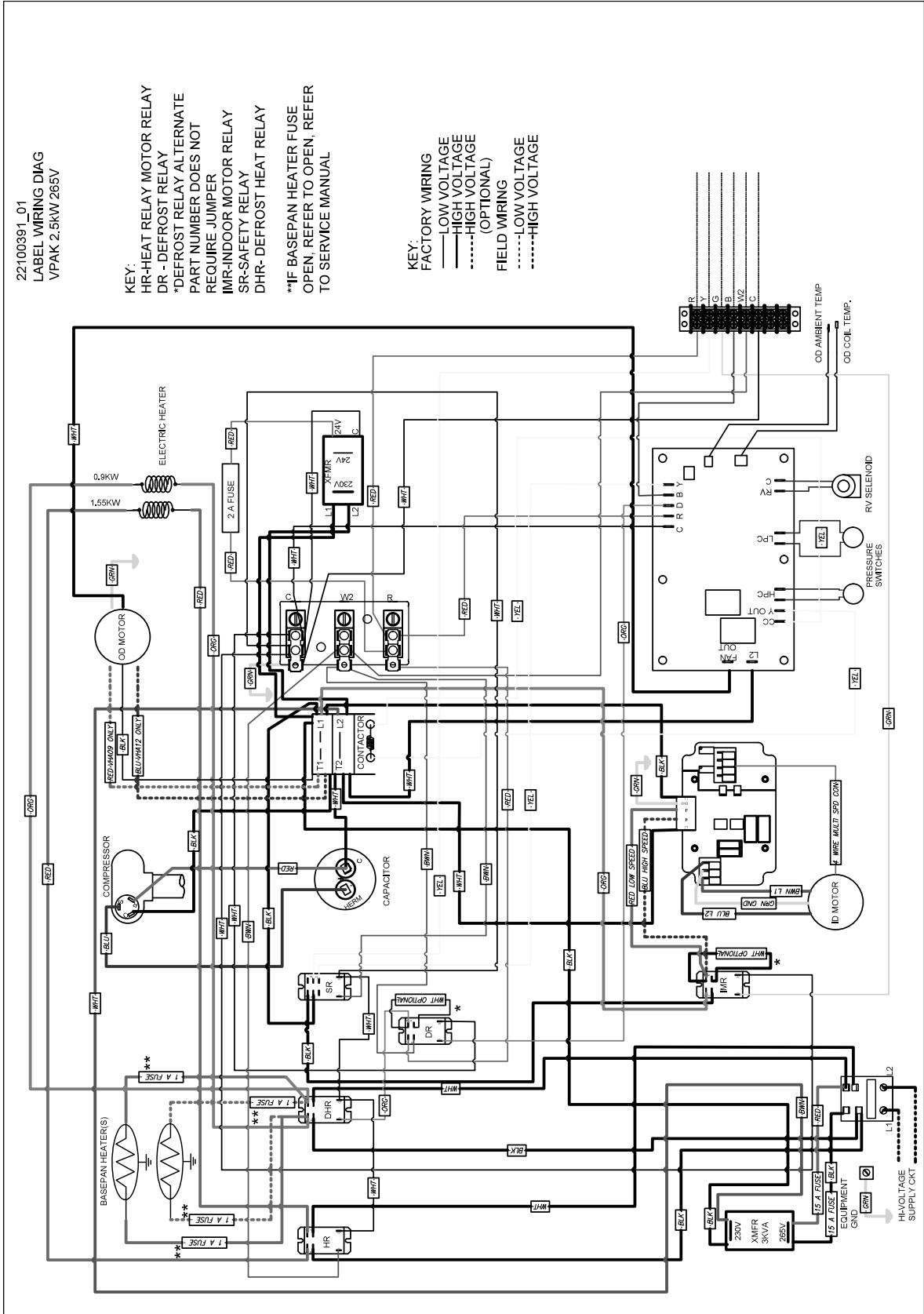

Wiring is subject to change. Always refer to the wiring diagram on the unit for the most up-to-date wiring.

WARNING

HIGH VOLTAGE!

DISCONNECT ALL POWER BEFORE SERVICING OR INSTALLING THIS UNIT.
MULTIPLE POWER SOURCES MAY BE PRESENT. FAILURE TO DO SO MAY
CAUSE PROPERTY DAMAGE, PERSONAL INJURY OR DEATH.

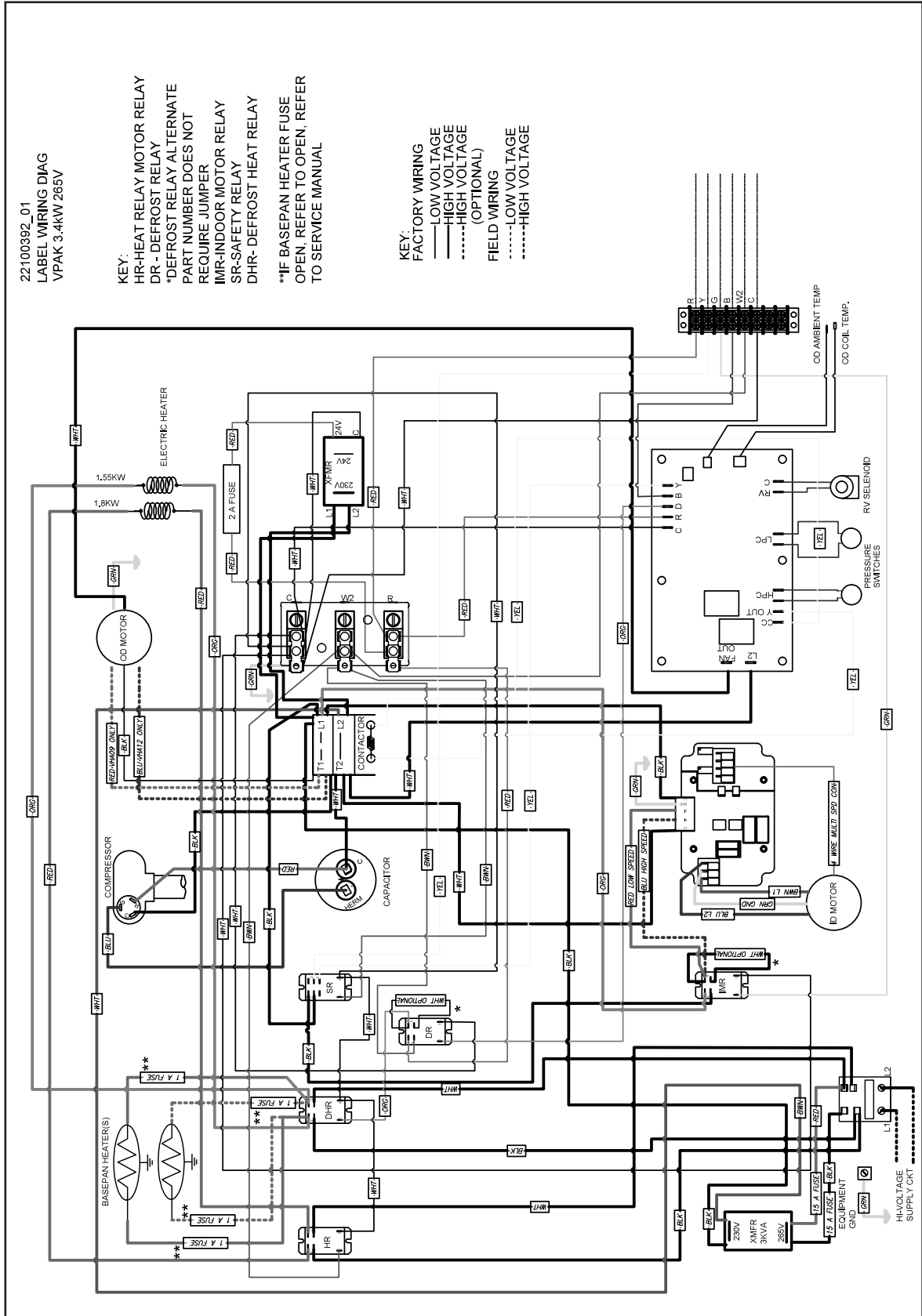

Wiring is subject to change. Always refer to the wiring diagram on the unit for the most up-to-date wiring.



WARNING
HIGH VOLTAGE!
 DISCONNECT ALL POWER BEFORE SERVICING OR INSTALLING THIS UNIT.
 MULTIPLE POWER SOURCES MAY BE PRESENT. FAILURE TO DO SO MAY
 CAUSE PROPERTY DAMAGE, PERSONAL INJURY OR DEATH.

22100393
 LABEL WIRING DIAG
 VPAK 5.0KW 265V

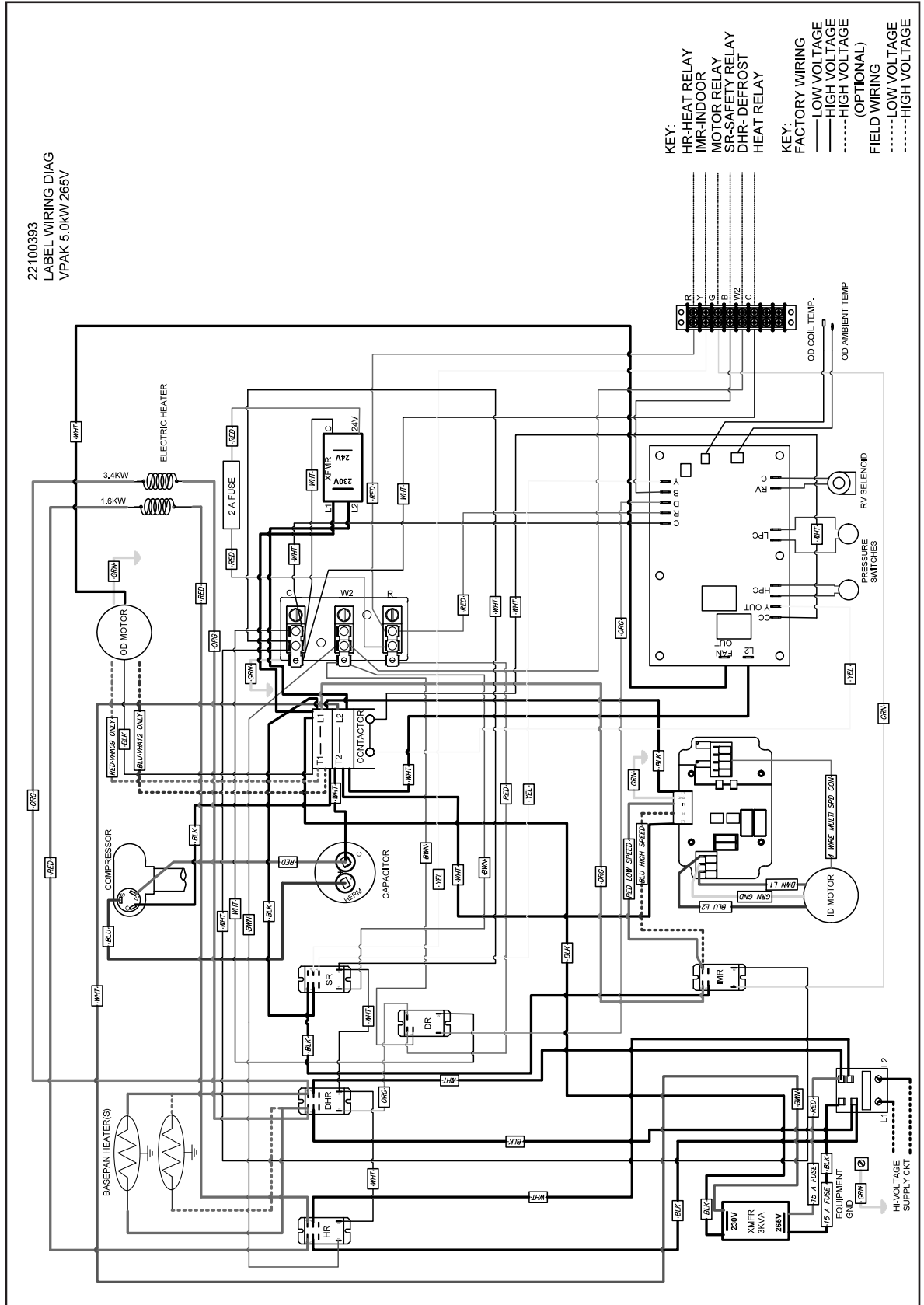

KEY:
 HR-HEAT RELAY
 IMP-INDOOR
 MOTOR RELAY
 SR-SAFETY RELAY
 DHR-DEFROST
 HEAT RELAY

KEY:
 FACTORY WIRING
 ——— LOW VOLTAGE
 ——— HIGH VOLTAGE
 HIGH VOLTAGE
 (OPTIONAL)
 FIELD WIRING
 - - - - - LOW VOLTAGE
 - - - - - HIGH VOLTAGE

Wiring is subject to change. Always refer to the wiring diagram on the unit for the most up-to-date wiring.



WARNING
HIGH VOLTAGE!
 DISCONNECT ALL POWER BEFORE SERVICING OR INSTALLING THIS UNIT.
 MULTIPLE POWER SOURCES MAY BE PRESENT. FAILURE TO DO SO MAY
 CAUSE PROPERTY DAMAGE, PERSONAL INJURY OR DEATH.

22100394_01
 LABEL WIRING DIAG
 VPAK 7.5KW 265V

KEY:
 HR-HEAT RELAY MOTOR RELAY
 DR - DEFROST RELAY
 *DEFROST RELAY ALTERNATE
 PART NUMBER DOES NOT
 REQUIRE JUMPER
 IMR-INDOOR MOTOR RELAY
 SR-SAFETY RELAY
 DHR- DEFROST HEAT RELAY
 **IF BASEPAN HEATER FUSE
 OPEN, REFER TO OPEN, REFER
 TO SERVICE MANUAL

KEY:
 FACTORY WIRING
 ——— LOW VOLTAGE
 ——— HIGH VOLTAGE
 - - - - - HIGH VOLTAGE
 (OPTIONAL)
 FIELD WIRING
 - - - - - LOW VOLTAGE
 - - - - - HIGH VOLTAGE

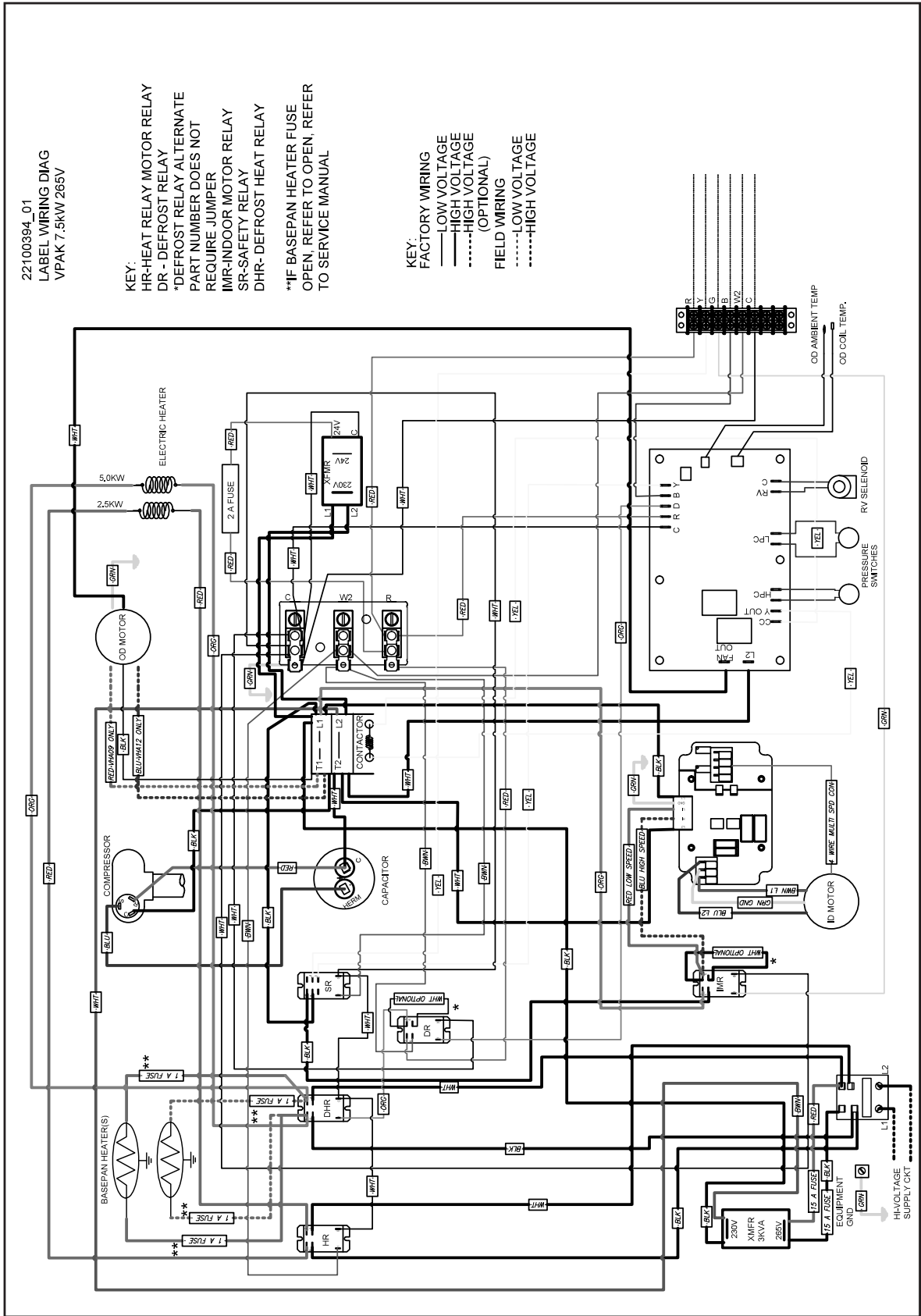

Wiring is subject to change. Always refer to the wiring diagram on the unit for the most up-to-date wiring.



WARNING
HIGH VOLTAGE!
 DISCONNECT ALL POWER BEFORE SERVICING OR INSTALLING THIS UNIT.
 MULTIPLE POWER SOURCES MAY BE PRESENT. FAILURE TO DO SO MAY
 CAUSE PROPERTY DAMAGE, PERSONAL INJURY OR DEATH.

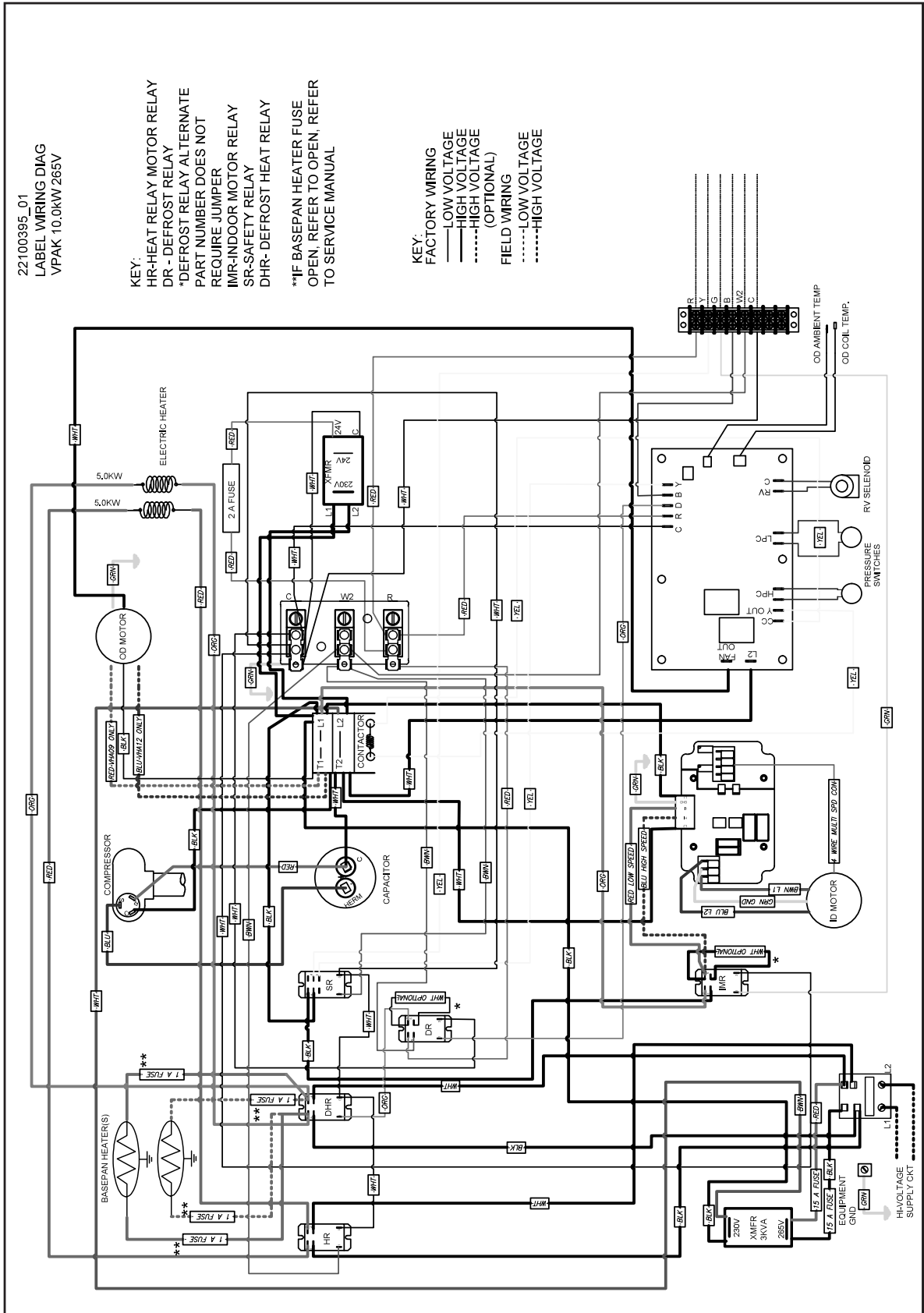

Wiring is subject to change. Always refer to the wiring diagram on the unit for the most up-to-date wiring.