



SiUS092411E

R-32

Service Manual

Inverter Pair RXT-A Series

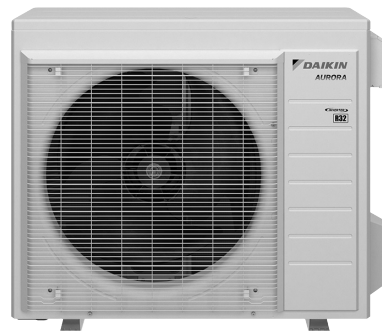

[Applied Models]

● Inverter Pair : Heat Pump

| | |
|---|-----------|
| Introduction | 1 |
| 1. Safety Cautions..... | 2 |
| 1.1 Warnings and Cautions Regarding Safety of Workers..... | 2 |
| 1.2 Warnings and Cautions Regarding Safety of Users..... | 7 |
| 2. Icons Used | 10 |
| 3. Revision History | 11 |
| | |
| Part 1 General Information | 12 |
| 1. Applicable Models | 13 |
| 2. Functions..... | 14 |
| | |
| Part 2 Specifications | 15 |
| 1. Specifications | 16 |
| | |
| Part 3 Printed Circuit Board Connector Wiring Diagram..... | 19 |
| 1. Indoor Unit..... | 20 |
| 2. Outdoor Unit..... | 22 |
| 2.1 RXT09AVJU9 | 22 |
| 2.2 RXT12AVJU9 | 24 |
| 2.3 RXT15/18/24AVJU9 | 25 |
| | |
| Part 4 Functions and Control | 26 |
| 1. Common Functions | 27 |
| 1.1 Temperature Control | 27 |
| 1.2 Frequency Principle..... | 27 |
| 1.3 Airflow Direction Control..... | 29 |
| 1.4 COMFORT AIRFLOW Operation | 30 |
| 1.5 Fan Speed Control for Indoor Unit | 31 |
| 1.6 Program Dry Operation | 32 |
| 1.7 Automatic Cooling/Heating Change-over | 33 |
| 1.8 Thermostat Control..... | 34 |
| 1.9 NIGHT SET Mode | 35 |
| 1.10 ECONO Operation | 35 |
| 1.11 POWERFUL Operation | 36 |
| 1.12 Brightness Setting of Indoor Unit Display | 37 |
| 1.13 Wireless LAN Connection | 38 |
| 1.14 Other Functions..... | 42 |
| 2. Thermistor Functions | 43 |
| 3. Control Specification | 44 |
| 3.1 Mode Hierarchy | 44 |
| 3.2 Frequency Control..... | 44 |
| 3.3 Controls at Mode Changing/Start-up..... | 46 |
| 3.4 Discharge Pipe Temperature Control..... | 48 |
| 3.5 Input Current Control..... | 49 |
| 3.6 High Pressure Protection Control..... | 50 |
| 3.7 Freeze-up Protection Control | 50 |
| 3.8 Heating Peak-cut Control | 51 |
| 3.9 Outdoor Fan Control..... | 52 |

| | |
|--|----|
| 3.10 Liquid Compression Protection Function..... | 52 |
| 3.11 Defrost Control | 53 |
| 3.12 Electronic Expansion Valve Control | 54 |
| 3.13 Malfunctions | 57 |

Part 5 Remote Controller 58

| | |
|---------------------------------------|----|
| 1. Applicable Remote Controller | 59 |
| 2. ARC480A83 | 60 |
| 3. BRC073A6 | 62 |
| 4. BRC944B2 | 66 |

Part 6 Service Diagnosis 67

| | |
|---|-----|
| 1. General Problem Symptoms and Check Items | 69 |
| 2. Troubleshooting with LED | 70 |
| 2.1 Indoor Unit..... | 70 |
| 2.2 Outdoor Unit..... | 70 |
| 3. Service Diagnosis | 71 |
| 3.1 ARC480 Series..... | 71 |
| 3.2 BRC073A6 | 74 |
| 4. Error Codes and Description | 76 |
| 5. Troubleshooting for Indoor Unit..... | 77 |
| 5.1 Indoor Unit PCB Abnormality | 77 |
| 5.2 Freeze-up Protection Control/Heating Peak-cut Control | 78 |
| 5.3 Indoor Fan Motor (DC Motor) or Related Abnormality | 79 |
| 5.4 Indoor Heat Exchanger Thermistor or Related Abnormality..... | 81 |
| 5.5 Room Temperature Sensor Abnormality/Humidity Sensor Abnormality | 82 |
| 5.6 Low-voltage Detection or Over-voltage Detection | 83 |
| 5.7 Signal Transmission Error (Between Indoor Unit and Outdoor Unit)..... | 85 |
| 5.8 Unspecified Voltage (Between Indoor Unit and Outdoor Unit)..... | 87 |
| 6. Troubleshooting for Outdoor Unit..... | 88 |
| 6.1 Outdoor Unit PCB Abnormality..... | 88 |
| 6.2 Actuation of High Pressure Switch | 89 |
| 6.3 OL Activation (Compressor Overload) | 90 |
| 6.4 Compressor Lock | 92 |
| 6.5 DC Fan Lock | 93 |
| 6.6 Input Overcurrent Detection | 94 |
| 6.7 Electronic Expansion Valve Coil Abnormality..... | 95 |
| 6.8 Four Way Valve Abnormality..... | 96 |
| 6.9 Discharge Pipe Temperature Control..... | 98 |
| 6.10 High Pressure Control in Cooling | 99 |
| 6.11 System Shutdown due to Temperature Abnormality in the Compressor..... | 101 |
| 6.12 Compressor Sensor System Abnormality | 102 |
| 6.13 High Pressure Switch System Abnormality | 103 |
| 6.14 Position Sensor Abnormality | 104 |
| 6.15 Fan IPM temperature error | 107 |
| 6.16 DC Voltage/Current Sensor Abnormality..... | 108 |
| 6.17 Thermistor or Related Abnormality (Outdoor Unit)..... | 109 |
| 6.18 Electrical Box Temperature Rise..... | 111 |

| | | |
|------|---|-----|
| 6.19 | Radiation Fin Temperature Rise | 112 |
| 6.20 | Output Overcurrent Detection | 113 |
| 6.21 | IGBT temperature error | 115 |
| 6.22 | Signal Transmission Error on Outdoor Unit PCB | 116 |
| 7. | Check | 117 |
| 7.1 | Thermistor Resistance Check | 117 |
| 7.2 | Indoor Fan Motor Connector Check | 118 |
| 7.3 | Power Supply Waveform Check..... | 118 |
| 7.4 | Electronic Expansion Valve Check..... | 119 |
| 7.5 | Four Way Valve Performance Check | 120 |
| 7.6 | Inverter Unit Refrigerant System Check..... | 120 |
| 7.7 | Inverter Analyzer Check | 121 |
| 7.8 | Outdoor Fan Motor Check..... | 123 |
| 7.9 | Installation Condition Check..... | 123 |
| 7.10 | Discharge Pressure Check..... | 124 |
| 7.11 | Outdoor Fan System Check | 124 |
| 7.12 | Main Circuit Short Check..... | 125 |
| 7.13 | Power Module Check | 127 |

Part 7 Trial Operation and Field Settings 129

| | | |
|-----|---|-----|
| 1. | Pump Down Operation..... | 130 |
| 2. | Forced Cooling Operation | 131 |
| 3. | Trial Operation | 132 |
| 4. | Field Settings | 134 |
| 4.1 | When 2 Units are Installed in 1 Room..... | 134 |
| 4.2 | Temperature Display Switch | 137 |
| 4.3 | Facility Setting (cooling at low outdoor temperature) | 138 |
| 4.4 | Warmer Airflow Setting..... | 139 |
| 4.5 | Drain Pan Heater..... | 140 |
| 4.6 | Service Mode of Wireless Remote Controller | 141 |
| 5. | Silicone Grease on Power Transistor/Diode Bridge..... | 143 |

Part 8 Appendix 144



| | | |
|-----|----------------------|-----|
| 1. | Piping Diagrams..... | 145 |
| 1.1 | Indoor Unit..... | 145 |
| 1.2 | Outdoor Unit..... | 146 |
| 2. | Wiring Diagrams..... | 149 |
| 2.1 | Indoor Unit..... | 149 |
| 2.2 | Outdoor Unit..... | 151 |
| 3. | Operation Limit..... | 154 |

Introduction

| | |
|--|----|
| 1. Safety Cautions..... | 2 |
| 1.1 Warnings and Cautions Regarding Safety of Workers..... | 2 |
| 1.2 Warnings and Cautions Regarding Safety of Users..... | 7 |
| 2. Icons Used | 10 |
| 3. Revision History | 11 |

1. Safety Cautions



Be sure to read the following safety cautions before conducting repair work. After the repair work is complete, be sure to conduct a test operation to ensure that the equipment operates normally, and explain the cautions for operating the product to the customer.

| | | | |
|---|--|---|-------------------------------------|
|  | This manual is for the person in charge of maintenance and inspection. |  Refrigerant Safety Group A2L | This appliance is filled with R-32. |
|---|--|---|-------------------------------------|







Caution Items





The caution items are classified into **Warning** and **Caution**. The **Warning** items are especially important since death or serious injury can result if they are not followed closely. The **Caution** items can also lead to serious accidents under some conditions if they are not followed. Therefore, be sure to observe all the safety caution items described below.









Pictograms

-  This symbol indicates an item for which caution must be exercised. The pictogram shows the item to which attention must be paid.
-  This symbol indicates a prohibited action. The prohibited item or action is shown in the illustration or near the symbol.
-  This symbol indicates an action that must be taken, or an instruction. The instruction is shown in the illustration or near the symbol.

1.1 Warnings and Cautions Regarding Safety of Workers

|  Warning | |
|--|---|
| <p>Do not store equipment in a room with fire sources (e.g., naked flames, gas appliances, electric heaters).</p> |  |
| <p>Be sure to disconnect the power cable from the socket before disassembling equipment for repair. Working on equipment that is connected to the power supply may cause an electrical shock. If it is necessary to supply power to the equipment to conduct the repair or inspect the circuits, do not touch any electrically charged sections of the equipment.</p> |  |
| <p>If refrigerant gas is discharged during repair work, do not touch the discharged refrigerant gas. Refrigerant gas may cause frostbite.</p> |  |
| <p>When disconnecting the suction or discharge pipe of the compressor at the welded section, evacuate the refrigerant gas completely at a well-ventilated place first. If there is gas remaining inside the compressor, the refrigerant gas or refrigerating machine oil discharges when the pipe is disconnected, and it may cause injury.</p> |  |
| <p>If refrigerant gas leaks during repair work, ventilate the area. Refrigerant gas may generate toxic gases when it contacts flames.</p> |  |
| <p>Be sure to discharge the capacitor completely before conducting repair work. The step-up capacitor supplies high-voltage electricity to the electrical components of the outdoor unit. A charged capacitor may cause an electrical shock.</p> |  |

|  Warning | |
|---|---|
| <p>Do not turn the air conditioner on or off by plugging in or unplugging the power cable. Plugging in or unplugging the power cable to operate the equipment may cause an electrical shock or fire.</p> |  |
| <p>Be sure to wear a safety helmet, gloves, and a safety belt when working in a high place (more than 2 m (6.5 ft)). Insufficient safety measures may cause a fall.</p> |  |
| <p>In case of R-32 / R-410A refrigerant models, be sure to use pipes, flare nuts and tools intended for the exclusive use with the R-32 / R-410A refrigerant. The use of materials for R-22 refrigerant models may cause a serious accident, such as a damage of refrigerant cycle or equipment failure.</p> |  |
| <p>Do not mix air or gas other than the specified refrigerant (R-32 / R-410A / R-22) in the refrigerant system. If air enters the refrigerant system, an excessively high pressure results, causing equipment damage and injury.</p> |  |

|  Caution | |
|--|---|
| <p>Do not repair electrical components with wet hands. Working on the equipment with wet hands may cause an electrical shock.</p> |  |
| <p>Do not clean the air conditioner with water. Washing the unit with water may cause an electrical shock.</p> |  |
| <p>Be sure to provide an earth / grounding when repairing the equipment in a humid or wet place, to avoid electrical shocks.</p> |  |
| <p>Be sure to turn off the power switch and unplug the power cable when cleaning the equipment. The internal fan rotates at a high speed, and may cause injury.</p> |  |
| <p>Be sure to conduct repair work with appropriate tools. The use of inappropriate tools may cause injury.</p> |  |
| <p>Be sure to check that the refrigerating cycle section has cooled down enough before conducting repair work. Working on the unit when the refrigerating cycle section is hot may cause burns.</p> |  |
| <p>Conduct welding work in a well-ventilated place. Using the welder in an enclosed room may cause oxygen deficiency.</p> |  |

■ Checks to the area

Prior to beginning work on systems containing flammable refrigerants, safety checks are necessary to ensure that the risk of ignition is minimized. For repair to the refrigerating system, provisions under **Work procedure to No ignition sources** below shall be completed prior to conducting work on the system.

■ Work procedure

Work shall be undertaken under a controlled procedure so as to minimize the risk of a flammable gas or vapor being present while the work is being performed.

■ General work area

All maintenance staff and others working in the local area shall be instructed on the nature of work being carried out. Work in confined spaces shall be avoided.

■ Checking for presence of refrigerant

The area shall be checked with an appropriate refrigerant detector prior to and during work, to ensure the technician is aware of potentially toxic or flammable atmospheres.

Ensure that the leak detection equipment being used is suitable for use with all applicable refrigerants, i.e. non-sparking, adequately sealed or intrinsically safe.

■ Presence of fire extinguisher

If any hot work is to be conducted on the refrigerating equipment or any associated parts, appropriate fire extinguishing equipment shall be available to hand. Have a dry powder or CO₂ fire extinguisher adjacent to the charging area.

■ No ignition sources

No person carrying out work in relation to a refrigerating system which involves exposing any pipe work shall use any sources of ignition in such a manner that it may lead to the risk of fire or explosion. All possible ignition sources, including cigarette smoking, should be kept sufficiently far away from the site of installation, repairing, removing and disposal, during which refrigerant can possibly be released to the surrounding space. Prior to work taking place, the area around the equipment is to be surveyed to make sure that there are no flammable hazards or ignition risks. "No Smoking" signs shall be displayed.

■ Ventilated area

Ensure that the area is in the open or that it is adequately ventilated before breaking into the system or conducting any hot work. A degree of ventilation shall continue during the period that the work is carried out. The ventilation should safely disperse any released refrigerant and preferably expel it externally into the atmosphere.

■ Checks to the refrigerating equipment

Where electrical components are being changed, they shall be fit for the purpose and to the correct specification.

At all times the manufacturer's maintenance and service guidelines shall be followed. If in doubt, consult the manufacturer's technical department for assistance.

The following checks shall be applied to installations using flammable refrigerants:

- The actual refrigerant charge is in accordance with the room size within which the refrigerant containing parts are installed;
- The ventilation machinery and outlets are operating adequately and are not obstructed;
- If an indirect refrigerating circuit is being used, the secondary circuit shall be checked for the presence of refrigerant;
- Marking to the equipment continues to be visible and legible. Markings and signs that are illegible shall be corrected;
- Refrigerating pipe or components are installed in a position where they are unlikely to be exposed to any substance which may corrode refrigerant containing components, unless the components are constructed of materials which are inherently resistant to being corroded or are suitably protected against being so corroded.

■ Checks to electrical devices

Repair and maintenance to electrical components shall include initial safety checks and component inspection procedures. If a fault exists that could compromise safety, then no electrical supply shall be connected to the circuit until it is satisfactorily dealt with. If the fault cannot be corrected immediately but it is necessary to continue operation, an adequate temporary solution shall be used. This shall be reported to the owner of the equipment so all parties are advised.

Initial safety checks shall include:

- that capacitors are discharged: this shall be done in a safe manner to avoid possibility of sparking;
- that no live electrical components and wiring are exposed while charging, recovering or purging the system;
- that there is continuity of earth bonding.

■ Repairs to sealed components

Sealed electrical components shall be replaced.

■ Repair to intrinsically safe components

Intrinsically safe components must be replaced.

■ Cabling

Check that cabling will not be subject to wear, corrosion, excessive pressure, vibration, sharp edges or any other adverse environmental effects. The check shall also take into account the effects of aging or continual vibration from sources such as compressors or fans.

■ Detection of flammable refrigerants

Under no circumstances shall potential sources of ignition be used in the searching for or detection of refrigerant leaks. A halide torch (or any other detector using a naked flame) shall not be used.

The following leak detection methods are deemed acceptable for all refrigerant systems. Electronic leak detectors may be used to detect refrigerant leaks but, in the case of flammable refrigerants, the sensitivity may not be adequate, or may need re-calibration. Ensure that the detector is not a potential source of ignition and is suitable for the refrigerant used. Leak detection equipment shall be set at a percentage of the LFL (lower flammability limit) of the refrigerant and shall be calibrated to the refrigerant employed, and the appropriate percentage of gas (25% maximum) is confirmed.

Leak detection fluids are also suitable for use with most refrigerants but the use of detergents containing chlorine shall be avoided as the chlorine may react with the refrigerant and corrode the copper pipe-work.

Note: Examples of leak detection fluids are

- bubble method,
- fluorescent method agents.

If a leak is suspected, all naked flames shall be removed/extinguished.

If a leakage of refrigerant is found which requires brazing, all of the refrigerant shall be recovered from the system, or isolated (by means of shut off valves) in a part of the system remote from the leak. Removal of refrigerant shall be according to the following clause,

Removal and evacuation.**■ Removal and evacuation**

When breaking into the refrigerant circuit to make repairs – or for any other purpose – conventional procedures shall be used. However, for flammable refrigerants it is important that best practice be followed, since flammability is a consideration. The following procedure shall be adhered to:

- safely remove refrigerant following local and national regulations;
- evacuate;
- purge the circuit with inert gas (optional for A2L);
- evacuate (optional for A2L);

- continuously flush or purge with inert gas when using flame to open circuit;
- open the circuit.

The refrigerant charge shall be recovered into the correct recovery cylinders if venting is not allowed by local and national codes. For appliances containing flammable refrigerants, the system shall be purged with oxygen-free nitrogen to render the appliance safe for flammable refrigerants. This process might need to be repeated several times. Compressed air or oxygen shall not be used for purging refrigerant systems.

For appliances containing flammable refrigerants, refrigerants purging shall be achieved by breaking the vacuum in the system with oxygen-free nitrogen and continuing to fill until the working pressure is achieved, then venting to atmosphere, and finally pulling down to a vacuum (optional for A2L). This process shall be repeated until no refrigerant is within the system (optional for A2L). When the final oxygen-free nitrogen charge is used, the system shall be vented down to atmospheric pressure to enable work to take place.

The outlet for the vacuum pump shall not be close to any potential ignition sources, and ventilation shall be available.

■ Charging procedures

In addition to conventional charging procedures, the following requirements shall be followed.

Ensure that contamination of different refrigerants does not occur when using charging equipment. Hoses or lines shall be as short as possible to minimize the amount of refrigerant contained in them.

- Cylinders shall be kept in an appropriate position according to the instructions.
- Ensure that the refrigerating system is earthed prior to charging the system with refrigerant.
- Label the system when charging is complete (if not already).
- Extreme care shall be taken not to overfill the refrigerating system.
- Prior to recharging the system, it shall be pressure-tested with the appropriate purging gas.

The system shall be leak-tested on completion of charging but prior to commissioning. A follow up leak test shall be carried out prior to leaving the site.

■ Decommissioning

Before carrying out this procedure, it is essential that the technician is completely familiar with the equipment and all its detail. It is recommended good practice that all refrigerants are recovered safely. Prior to the task being carried out, an oil and refrigerant sample shall be taken in case analysis is required prior to re-use of recovered refrigerant. It is essential that electrical power is available before the task is commenced.

- a) Become familiar with the equipment and its operation.
- b) Isolate system electrically.
- c) Before attempting the procedure, ensure that:
 - ◆ mechanical handling equipment is available, if required, for handling refrigerant cylinders;
 - ◆ all personal protective equipment is available and being used correctly;
 - ◆ the recovery process is supervised at all times by a competent person;
 - ◆ recovery equipment and cylinders conform to the appropriate standards.
- d) Pump down refrigerant system, if possible.
- e) If a vacuum is not possible, make a manifold so that refrigerant can be removed from various parts of the system.
- f) Make sure that cylinder is situated on the scales before recovery takes place.
- g) Start the recovery machine and operate in accordance with instructions.
- h) Do not overfill cylinders (no more than 80% volume liquid charge).
- i) Do not exceed the maximum working pressure of the cylinder, even temporarily.
- j) When the cylinders have been filled correctly and the process completed, make sure that the cylinders and the equipment are removed from site promptly and all isolation valves on the equipment are closed off.
- k) Recovered refrigerant shall not be charged into another refrigerating system unless it has been cleaned and checked.

■ **Labelling**

Equipment shall be labelled stating that it has been de-commissioned and emptied of refrigerant. The label shall be dated and signed. For appliances containing flammable refrigerants, ensure that there are labels on the equipment stating the equipment contains flammable refrigerant.

■ **Recovery**

When removing refrigerant from a system, either for servicing or decommissioning, it is recommended good practice that all refrigerants are removed safely.







When transferring refrigerant into cylinders, ensure that only appropriate refrigerant recovery cylinders are employed. Ensure that the correct number of cylinders for holding the total system charge is available. All cylinders to be used are designated for the recovered refrigerant and labelled for that refrigerant (i.e. special cylinders for the recovery of refrigerant). Cylinders shall be complete with pressure-relief valve and associated shut-off valves in good working order. Empty recovery cylinders are evacuated and, if possible, cooled before recovery occurs.









The recovery equipment shall be in good working order with a set of instructions concerning the equipment that is at hand and shall be suitable for the recovery of the flammable refrigerant. If in doubt, the manufacturer should be consulted. In addition, a set of calibrated weighing scales shall be available and in good working order. Hoses shall be complete with leak-free disconnect couplings and in good condition.





The recovered refrigerant shall be processed according to local legislation in the correct recovery cylinder, and the relevant waste transfer note arranged. Do not mix refrigerants in recovery units and especially not in cylinders.







If compressors or compressor oils are to be removed, ensure that they have been evacuated to an acceptable level to make certain that flammable refrigerant does not remain within the lubricant. The compressor body shall not be heated by an open flame or other ignition sources to accelerate this process. When oil is drained from a system, it shall be carried out safely.

1.2 Warnings and Cautions Regarding Safety of Users

|  Warning | |
|--|---|
| Do not store the equipment in a room with fire sources (e.g., naked flames, gas appliances, electric heaters). |  |
| Be sure to use parts listed in the service parts list of the applicable model and appropriate tools to conduct repair work. Never attempt to modify the equipment. The use of inappropriate parts or tools may cause an electrical shock, excessive heat generation or fire. |  |
| If the power cable and lead wires are scratched or have deteriorated, be sure to replace them. Damaged cable and wires may cause an electrical shock, excessive heat generation or fire. |  |
| Do not use a joined power cable or extension cable, or share the same power outlet with other electrical appliances, since it may cause an electrical shock, excessive heat generation or fire. |  |
| Be sure to use an exclusive power circuit for the equipment, and follow the local technical standards related to the electrical equipment, the internal wiring regulations, and the instruction manual for installation when conducting electrical work. Insufficient power circuit capacity and improper electrical work may cause an electrical shock or fire. |  |





|  Warning | |
|---|---|
| <p>Be sure to use the specified cable for wiring between the indoor and outdoor units. Make the connections securely and route the cable properly so that there is no force pulling the cable at the connection terminals. Improper connections may cause excessive heat generation or fire.</p> |  |
| <p>When wiring between the indoor and outdoor units, make sure that the terminal cover does not lift off or dismount because of the cable. If the cover is not mounted properly, the terminal connection section may cause an electrical shock, excessive heat generation or fire.</p> |  |
| <p>Do not damage or modify the power cable. Damaged or modified power cables may cause an electrical shock or fire. Placing heavy items on the power cable, or heating or pulling the power cable may damage it.</p> |  |
| <p>Do not mix air or gas other than the specified refrigerant (R-32 / R-410A / R-22) in the refrigerant system. If air enters the refrigerant system, an excessively high pressure results, causing equipment damage and injury.</p> |  |
| <p>If the refrigerant gas leaks, be sure to locate the leaking point and repair it before charging the refrigerant. After charging the refrigerant, make sure that there is no leak. If the leaking point cannot be located and the repair work must be stopped, be sure to pump-down, and close the service valve, to prevent refrigerant gas from leaking into the room. Refrigerant gas itself is harmless, but it may generate toxic gases when it contacts flames, such as those from fan type and other heaters, stoves and ranges.</p> |  |
| <p>When relocating the equipment, make sure that the new installation site has sufficient strength to withstand the weight of the equipment. If the installation site does not have sufficient strength or the installation work is not conducted securely, the equipment may fall and cause injury.</p> |  |
| <p>Check to make sure that the power cable plug is not dirty or loose, then insert the plug into a power outlet securely. If the plug is dusty or has a loose connection, it may cause an electrical shock or fire.</p> |  |
| <p>When replacing the coin battery in the remote controller, be sure to dispose of the old battery to prevent children from swallowing it. If a child swallows the coin battery, see a doctor immediately.</p> |  |

|  Caution | |
|--|---|
| <p>Installation of a leakage breaker is necessary in some cases depending on the conditions of the installation site, to prevent electrical shocks.</p> |  |
| <p>Do not install the equipment in a place where there is a possibility of combustible gas leaks. If combustible gas leaks and remains around the unit, it may cause a fire.</p> |  |
| <p>Check to see if parts and wires are mounted and connected properly, and if connections at the soldered or crimped terminals are secure. Improper installation and connections may cause excessive heat generation, fire or an electrical shock.</p> |  |

|  Caution | |
|--|--|
| <p>If the installation platform or frame has corroded, replace it. A corroded installation platform or frame may cause the unit to fall, resulting in injury.</p> |  |
| <p>Check the earth / grounding, and repair it if the equipment is not properly earthed / grounded. Improper earth / grounding may cause an electrical shock.</p> |  |
| <p>Be sure to measure insulation resistance after the repair, and make sure that the resistance is 1 MΩ or higher. Faulty insulation may cause an electrical shock.</p> |  |
| <p>Be sure to check the drainage of the indoor unit after the repair. Faulty drainage may cause water to enter the room and wet the furniture and floor.</p> |  |
| <p>Do not tilt the unit when removing it. The water inside the unit may spill and wet the furniture and floor.</p> |  |

2. Icons Used

The following icons are used to attract the attention of the reader to specific information.

| Icon | Type of Information | Description |
|---|---------------------|--|
|  Warning | Warning | Warning is used when there is danger of personal injury. |
|  Caution | Caution | Caution is used when there is danger that the reader, through incorrect manipulation, may damage equipment, lose data, get an unexpected result or have to restart (part of) a procedure. |
|  Note | Note | Note provides information that is not indispensable, but may nevertheless be valuable to the reader, such as tips and tricks. |
|  Reference | Reference | Reference guides the reader to other places in this binder or in this manual, where he/she will find additional information on a specific topic. |

3. Revision History

| Month/Year | Version | Revised contents |
|------------|-------------|------------------|
| 02 / 2025 | SiUS092411E | First edition |

Part 1

General Information

| | |
|----------------------------|----|
| 1. Applicable Models | 13 |
| 2. Functions..... | 14 |

1. Applicable Models

Indoor Unit

FTXV09AVJU9
FTXV12AVJU9
FTXV15AVJU9
FTXV18AVJU9
FTXV24AVJU9

Outdoor Unit

RXT09AVJU9
RXT12AVJU9
RXT15AVJU9
RXT18AVJU9
RXT24AVJU9

2. Functions

| Category | Functions | FTXV Series | | |
|---------------------------------------|--|-------------------|-----------------|-----------------|
| | | 09 class | 12 class | 15/18/24 class |
| Basic Function | Inverter (with inverter power control) | ● | ● | ● |
| | Operation limit | Refer to page 154 | | |
| | PAM control | — | ● | ● |
| | Standby electricity saving | — | — | — |
| Compressor | Swing compressor | ● | ● | ● |
| | Reluctance DC motor | ● | ● | ● |
| Comfortable Airflow | Power-airflow flap (horizontal blade) | ● | ● | — |
| | Power-airflow dual flaps (horizontal blades) | — | — | ● |
| | Wide-angle louvers (vertical blades) | ● | ● | ● |
| | Auto-swing (up and down) | ● | ● | ● |
| | Auto-swing (right and left) | — | — | — |
| | 3-D airflow | — | — | — |
| | COMFORT AIRFLOW operation | ● | ● | ● |
| Comfort Control | Auto fan speed | ● | ● | ● |
| | Switchable fan speed | ● | ● | ● |
| | Indoor unit quiet operation | ● | ● | ● |
| | OUTDOOR UNIT QUIET operation | — | — | — |
| | INTELLIGENT EYE operation (auto energy saving) | — | — | — |
| | Quick warming function | — | — | — |
| | Hot-start function | ● | ● | ● |
| | Automatic defrosting | ● | ● | ● |
| Operation | Automatic cooling/heating change-over | ● | ● | ● |
| | Program dry operation | ● | ● | ● |
| | Fan only | ● | ● | ● |
| Lifestyle Convenience | POWERFUL operation (inverter) | ● | ● | ● |
| | ECONO operation | ● | ● | ● |
| | Indoor unit ON/OFF switch | ● | ● | ● |
| | Signal receiving sign | ● | ● | ● |
| | R/C with back light | ● | ● | ● |
| Health and Cleanliness | Titanium apatite deodorizing filter | ● | ● | ● |
| | Mold proof air filter | ● | ● | ● |
| | Wipe-clean flat panel | ● | ● | ● |
| | Washable grille | — | — | — |
| Timer | WEEKLY TIMER operation | — | — | — |
| | 24-hour ON/OFF TIMER | — | — | — |
| | Count up-down ON/OFF timer | ● | ● | ● |
| | NIGHT SET mode | ● | ● | ● |
| Worry Free (Reliability & Durability) | Auto-restart (after power failure) | ● | ● | ● |
| | Self-diagnosis (R/C, LED) | ● | ● | ● |
| Flexibility | Chargeless | 49.2 ft. (15 m) | 49.2 ft. (15 m) | 49.2 ft. (15 m) |
| | Either side drain (left or right) | ● | ● | ● |
| | Low temperature cooling operation | 5°F (–15°C) | 5°F (–15°C) | 5°F (–15°C) |
| | °F/°C changeover R/C temperature display (factory setting: °F) | ● | ● | ● |
| Remote Control | Remote control adaptor (normal open pulse contact) | Option | Option | Option |
| | Remote control adaptor (normal open contact) | Option | Option | Option |
| | DIII-NET compatible (adaptor) | Option | Option | Option |
| | Wireless LAN connection | ● | ● | ● |
| Remote Controller | Wireless | ● | ● | ● |
| | Wired | Option | Option | Option |

● : Available

— : Not available

Part 2 Specifications

1. Specifications16

1. Specifications

| Model | Indoor Unit | | FTXV09AVJU9 | | FTXV12AVJU9 | |
|--|-----------------|---------------------------|--|-------------------------|--|-------------------------|
| | Outdoor Unit | | RXT09AVJU9 | | RXT12AVJU9 | |
| | | | Cooling | Heating | Cooling | Heating |
| Power Supply | | | 1 ϕ, 208 ~ 230 V, 60 Hz | | 1 ϕ, 208 ~ 230 V, 60 Hz | |
| Capacity Rated (Min. ~ Max.) | Btu/h | | 9,000 (4,400 ~ 11,200) | 10,900 (4,400 ~ 16,000) | 10,600 (4,400 ~ 14,600) | 13,500 (4,400 ~ 18,800) |
| Running Current (Rated) | A | | 4.34 - 3.93 | 3.97 - 3.59 | 4.35 - 3.94 | 5.50 - 4.98 |
| Power Consumption (Rated) | W | | 738 - 738 | 807 - 807 | 883 - 883 | 1,130 - 1,130 |
| Power Factor (Rated) | % | | 81.8 - 81.7 | 97.7 - 97.7 | 97.6 - 97.5 | 98.8 - 98.7 |
| SEER2 | | | 21.0 | — | 20.0 | — |
| HSPF2 | | | — | 10.2 | — | 10.2 |
| EER2 (Rated) | Btu/h·W | | 12.2 | — | 12.0 | — |
| COP2@5°F (Rated) | W/W | | — | 1.8 | — | 1.8 |
| Piping Connection | Liquid | in. (mm) | ϕ 1/4 (6.4) | | ϕ 1/4 (6.4) | |
| | Gas | in. (mm) | ϕ 3/8 (9.5) | | ϕ 3/8 (9.5) | |
| | Drain | in. (mm) | ϕ 5/8 (16) | | ϕ 5/8 (16) | |
| Heat Insulation | | | Both Liquid and Gas Pipes | | Both Liquid and Gas Pipes | |
| Max. Interunit Piping Length | ft (m) | | 65-5/8 (20) | | 65-5/8 (20) | |
| Max. Interunit Height Difference | ft (m) | | 49-1/4 (15) | | 49-1/4 (15) | |
| Chargeless | ft (m) | | 49-1/4 (15) | | 49-1/4 (15) | |
| Amount of Additional Charge of Refrigerant | oz/ft (g/m) | | 0.22 (20) | | 0.22 (20) | |
| Indoor Unit | | | FTXV09AVJU9 | | FTXV12AVJU9 | |
| Front Panel Color | | | White (N9.5) | | White (N9.5) | |
| Airflow Rates | H / M / L / SL | cfm | 381 / 272 / 230 / 124 | 385 / 304 / 230 / 194 | 392 / 293 / 226 / 120 | 438 / 318 / 240 / 205 |
| | | m ³ /min | 10.8 / 7.7 / 6.5 / 3.5 | 10.9 / 8.6 / 6.5 / 5.5 | 11.1 / 8.3 / 6.4 / 3.4 | 12.4 / 9.0 / 6.8 / 5.8 |
| Fan | Type | | Cross Flow Fan | | Cross Flow Fan | |
| | Drive Input | A | 0.20 | | 0.23 | |
| | Speed | Steps | 5 Steps, Quiet, Auto | | 5 Steps, Quiet, Auto | |
| Air Direction Control | | | Right, Left, Horizontal, Downward | | Right, Left, Horizontal, Downward | |
| Air Filter | | | Removable, Washable | | Removable, Washable | |
| Running Current (Rated) | A | | 0.14 - 0.13 | 0.13 - 0.12 | 0.17 - 0.15 | 0.20 - 0.18 |
| Power Consumption (Rated) | W | | 26 - 26 | 25 - 25 | 29 - 29 | 35 - 35 |
| Power Factor (Rated) | % | | 90.4 - 86.2 | 90.9 - 87.3 | 81.3 - 84.7 | 83.7 - 82.7 |
| Temperature Control | | | Microcomputer Control | | Microcomputer Control | |
| Dimensions (H × W × D) | in. (mm) | | 11-1/4 × 30-5/16 × 8-3/4 (286 × 770 × 223) | | 11-1/4 × 30-5/16 × 8-3/4 (286 × 770 × 223) | |
| Packaged Dimensions (H × W × D) | in. (mm) | | 12-5/8 × 32-11/16 × 14-3/16 (320 × 830 × 360) | | 12-5/8 × 32-11/16 × 14-3/16 (320 × 830 × 360) | |
| Weight (Mass) | lbs (kg) | | 19 (9) | | 19 (9) | |
| Gross Weight (Gross Mass) | lbs (kg) | | 24 (11) | | 24 (11) | |
| Sound Pressure Level | H / M / L / SL | dB(A) | 43 / 35 / 31 / 19 | 41 / 35 / 28 / 25 | 45 / 37 / 31 / 19 | 45 / 37 / 30 / 26 |
| Outdoor Unit | | | RXT09AVJU9 | | RXT12AVJU9 | |
| Casing Color | | | Ivory White | | Ivory White | |
| Heat Exchanger | Fin Spec / Tube | | Waffle Fin (PE) / ϕ 7 Hi-XSL Tube | | Waffle Fin (PE) / ϕ 7 Hi-XSL Tube | |
| Compressor | Type | | Hermetically Sealed Swing Type | | Hermetically Sealed Swing Type | |
| | Model | | 1Y091BKCX1A | | 2Y147BKBX1A | |
| Refrigerant Oil | Type | | FW68DA | | FW68DA | |
| | Charge | oz (L) | 12.68 (0.375) | | 21.98 (0.650) | |
| Refrigerant | Type | | R-32 | | R-32 | |
| | Charge | lbs (kg) | 1.65 (0.75) | | 1.74 (0.79) | |
| Airflow Rate | | cfm (m ³ /min) | 1,088 (30.8) | 1,006 (28.5) | 1,088 (30.8) | 1,126 (31.9) |
| Fan | Type | | Propeller | | Propeller | |
| | Drive Input | A | 0.15 | | 0.17 | |
| Running Current (Rated) | A | | 4.20 - 3.80 | 3.84 - 3.47 | 4.18 - 3.79 | 5.30 - 4.80 |
| Power Consumption (Rated) | W | | 712 - 712 | 782 - 782 | 854 - 854 | 1,095 - 1,095 |
| Power Factor (Rated) | % | | 81.5 - 81.5 | 98.0 - 98.0 | 98.3 - 98.1 | 99.3 - 99.2 |
| Dimensions (H × W × D) | in. (mm) | | 21-15/16 × 26-9/16 × 11-3/16 (557 × 675 × 284) | | 21-15/16 × 26-9/16 × 11-3/16 (557 × 675 × 284) | |
| Packaged Dimensions (H × W × D) | in. (mm) | | 24-7/16 × 31-1/4 × 14-1/8 (620 × 794 × 359) | | 24-7/16 × 31-1/4 × 14-1/8 (620 × 794 × 359) | |
| Weight (Mass) | lbs (kg) | | 63 (29) | | 73 (33) | |
| Gross Weight (Gross Mass) | lbs (kg) | | 68 (31) | | 77 (35) | |
| Sound Pressure Level | | dB(A) | 49 | 51 | 50 | 52 |
| Conditions Based on | Indoor | | 80.0°FDB (26.7°CDB) / 67.0°FWB (19.4°CWB) | | 80.0°FDB (26.7°CDB) / 67.0°FWB (19.4°CWB) | |
| | Outdoor | | 95.0°FDB (35.0°CDB) / 75.0°FWB (23.9°CWB) | | 95.0°FDB (35.0°CDB) / 75.0°FWB (23.9°CWB) | |
| | Piping Length | | 25 ft (7.5 m) | | 25 ft (7.5 m) | |
| Drawing No. | | | 3D153886B | | 3D153886B | |
| Note | | | SL: The quiet fan level of the airflow rate setting. | | | |

| Conversion Formulae |
|----------------------------------|
| kcal/h = kW × 860 |
| Btu/h = kW × 3412 |
| cfm = m ³ /min × 35.3 |

| Model | Indoor Unit | | FTXV15AVJU9 | | FTXV18AVJU9 | |
|--|---------------------------|---------------------|--|---------------------------|--|---------------------------|
| | Outdoor Unit | | RXT15AVJU9 | | RXT18AVJU9 | |
| | | | Cooling | Heating | Cooling | Heating |
| Power Supply | | | 1 ϕ , 208 ~ 230 V, 60 Hz | | 1 ϕ , 208 ~ 230 V, 60 Hz | |
| Capacity Rated (Min. ~ Max.) | Btu/h | | 15,000 (5,800 ~ 18,400) | 18,300 (5,800 ~ 24,600) | 18,000 (6,900 ~ 22,000) | 21,600 (5,800 ~ 28,000) |
| Running Current (Rated) | A | | 6.45 - 5.83 | 7.56 - 6.84 | 7.75 - 7.01 | 9.31 - 8.42 |
| Power Consumption (Rated) | W | | 1,230 - 1,230 | 1,490 - 1,490 | 1,500 - 1,500 | 1,918 - 1,918 |
| Power Factor (Rated) | % | | 91.7 - 91.7 | 94.8 - 94.7 | 93.1 - 93.1 | 99.0 - 99.0 |
| SEER2 | | | 21.0 | — | 21.0 | — |
| HSPF2 | | | — | 10.5 | — | 9.6 |
| EER2 (Rated) | Btu/h·W | | 12.2 | — | 12.0 | — |
| COP2@5°F (Rated) | W/W | | — | 1.8 | — | 1.8 |
| Piping Connection | Liquid | in. (mm) | ϕ 1/4 (6.4) | | ϕ 1/4 (6.4) | |
| | Gas | in. (mm) | ϕ 1/2 (12.7) | | ϕ 1/2 (12.7) | |
| | Drain | in. (mm) | ϕ 5/8 (16) | | ϕ 5/8 (16) | |
| Heat Insulation | | | Both Liquid and Gas Pipes | | Both Liquid and Gas Pipes | |
| Max. Interunit Piping Length | ft (m) | | 98-1/2 (30) | | 98-1/2 (30) | |
| Max. Interunit Height Difference | ft (m) | | 65-5/8 (20) | | 65-5/8 (20) | |
| Chargeless | ft (m) | | 49-1/4 (15) | | 49-1/4 (15) | |
| Amount of Additional Charge of Refrigerant | oz/ft (g/m) | | 0.22 (20) | | 0.22 (20) | |
| Indoor Unit | | | FTXV15AVJU9 | | FTXV18AVJU9 | |
| Front Panel Color | | | White (N9.5) | | White (N9.5) | |
| Airflow Rates | H / M / L / SL | cfm | 540 / 470 / 381 / 339 | 636 / 537 / 452 / 388 | 565 / 463 / 378 / 335 | 717 / 572 / 452 / 388 |
| | | m ³ /min | 15.3 / 13.3 / 10.8 / 9.6 | 18.0 / 15.2 / 12.8 / 11.0 | 16.0 / 13.1 / 10.7 / 9.5 | 20.3 / 16.2 / 12.8 / 11.0 |
| Fan | Type | Cross Flow Fan | | Cross Flow Fan | | |
| | Drive Input | A | | 0.31 | | |
| | Speed | Steps | | 5 Steps, Quiet, Auto | | |
| Air Direction Control | | | Right, Left, Horizontal, Downward | | Right, Left, Horizontal, Downward | |
| Air Filter | | | Removable, Washable | | Removable, Washable | |
| Running Current (Rated) | A | | 0.19 - 0.17 | 0.20 - 0.18 | 0.20 - 0.18 | 0.29 - 0.26 |
| Power Consumption (Rated) | W | | 36 - 36 | 39 - 39 | 39 - 39 | 54 - 54 |
| Power Factor (Rated) | % | | 91.1 - 93.5 | 93.8 - 92.3 | 93.8 - 92.5 | 89.5 - 89.3 |
| Temperature Control | | | Microcomputer Control | | Microcomputer Control | |
| Dimensions (H × W × D) | in. (mm) | | 11-5/8 × 39 × 10-3/8 (295 × 990 × 263) | | 11-5/8 × 39 × 10-3/8 (295 × 990 × 263) | |
| Packaged Dimensions (H × W × D) | in. (mm) | | 15-3/16 × 43-3/8 × 15-5/16 (386 × 1,102 × 389) | | 15-3/16 × 43-3/8 × 15-5/16 (386 × 1,102 × 389) | |
| Weight (Mass) | lbs (kg) | | 27 (13) | | 27 (13) | |
| Gross Weight (Gross Mass) | lbs (kg) | | 37 (17) | | 37 (17) | |
| Sound Pressure Level | H / M / L / SL | dB(A) | 45 / 41 / 36 / 33 | 45 / 41 / 37 / 33 | 48 / 43 / 38 / 33 | 49 / 42 / 37 / 33 |
| Outdoor Unit | | | RXT15AVJU9 | | RXT18AVJU9 | |
| Casing Color | | | Ivory White | | Ivory White | |
| Heat Exchanger | Fin Spec / Tube | | Waffle Fin (PE) / ϕ 7 Hi-XSL Tube | | Waffle Fin (PE) / ϕ 7 Hi-XSL Tube | |
| Compressor | Type | | Hermetically Sealed Swing Type | | Hermetically Sealed Swing Type | |
| | Model | | 2Y147BKBX1A | | 2Y260BPAX1A | |
| Refrigerant Oil | Type | | FW68DA | | FW68DA | |
| | Charge | oz (L) | 21.98 (0.65) | | 30.43 (0.90) | |
| Refrigerant | Type | | R-32 | | R-32 | |
| | Charge | lbs (kg) | 2.45 (1.11) | | 3.04 (1.38) | |
| Airflow Rate | cfm (m ³ /min) | | 2,097 (59.4) | 2,327 (65.9) | 2,383 (67.5) | 2,327 (65.9) |
| Fan | Type | | Propeller | | Propeller | |
| | Drive Input | A | | 0.38 | | 0.41 |
| Running Current (Rated) | A | | 6.26 - 5.66 | 7.36 - 6.66 | 7.55 - 6.83 | 9.02 - 8.16 |
| Power Consumption (Rated) | W | | 1,194 - 1,194 | 1,451 - 1,451 | 1,461 - 1,461 | 1,864 - 1,864 |
| Power Factor (Rated) | % | | 91.7 - 91.7 | 94.8 - 94.7 | 93.0 - 93.1 | 99.4 - 99.3 |
| Dimensions (H × W × D) | in. (mm) | | 29-1/2 × 34-1/4 × 12-5/8 (750 × 870 × 320) | | 29-1/2 × 34-1/4 × 12-5/8 (750 × 870 × 320) | |
| Packaged Dimensions (H × W × D) | in. (mm) | | 32-1/16 × 40-5/16 × 16 (814 × 1,024 × 406) | | 32-1/16 × 40-5/16 × 16 (814 × 1,024 × 406) | |
| Weight (Mass) | lbs (kg) | | 113 (52) | | 127 (58) | |
| Gross Weight (Gross Mass) | lbs (kg) | | 121 (55) | | 135 (61) | |
| Sound Pressure Level | dB(A) | | 52 | 57 | 55 | 57 |
| Conditions Based on | Indoor | | 80.0°FDB (26.7°CDB) / 67.0°FWB (19.4°CWB) | | 80.0°FDB (26.7°CDB) / 67.0°FWB (19.4°CWB) | |
| | Outdoor | | 95.0°FDB (35.0°CDB) / 75.0°FWB (23.9°CWB) | | 95.0°FDB (35.0°CDB) / 75.0°FWB (23.9°CWB) | |
| | Piping Length | | 25 ft (7.5 m) | | 25 ft (7.5 m) | |
| Drawing No. | | | 3D153395C | | 3D153395C | |
| Note | | | SL: The quiet fan level of the airflow rate setting. | | | |

| | |
|----------------------------------|--|
| Conversion Formulae | |
| kcal/h = kW × 860 | |
| Btu/h = kW × 3412 | |
| cfm = m ³ /min × 35.3 | |

| Model | Indoor Unit | | FTXV24AVJU9 | |
|--|--|--|--------------------------|---|
| | Outdoor Unit | | RXT24AVJU9 | |
| | | Cooling | | Heating |
| Power Supply | | 1 ϕ , 208 ~ 230 V, 60 Hz | | |
| Capacity Rated (Min. ~ Max.) | Btu/h | 22,400 (7,000 ~ 26,400) | | 24,000 (6,200 ~ 32,000) |
| Running Current (Rated) | A | 9.47 - 8.56 | | 11.35 - 10.27 |
| Power Consumption (Rated) | W | 1,867 - 1,867 | | 2,345 - 2,345 |
| Power Factor (Rated) | % | 94.8 - 94.8 | | 99.3 - 99.3 |
| SEER2 | | 21.0 | | — |
| HSPF2 | | — | | 9.5 |
| EER2 (Rated) | Btu/h·W | 12.0 | | — |
| COP2@5°F (Rated) | W/W | — | | 1.8 |
| Piping Connection | Liquid | in. (mm) | ϕ 1/4 (6.4) | |
| | Gas | in. (mm) | ϕ 5/8 (15.9) | |
| | Drain | in. (mm) | ϕ 5/8 (16) | |
| Heat Insulation | | Both Liquid and Gas Pipes | | |
| Max. Interunit Piping Length | ft (m) | 98-1/2 (30) | | |
| Max. Interunit Height Difference | ft (m) | 65-5/8 (20) | | |
| Chargeless | ft (m) | 49-1/4 (15) | | |
| Amount of Additional Charge of Refrigerant | oz/ft (g/m) | 0.22 (20) | | |
| Indoor Unit | | FTXV24AVJU9 | | |
| Front Panel Color | | White (N9.5) | | |
| Airflow Rates | H / M / L / SL | cfm | 629 / 501 / 378 / 335 | |
| | | m ³ /min | 17.8 / 14.2 / 10.7 / 9.5 | |
| Fan | Type | Cross Flow Fan | | |
| | Drive Input | A | | |
| | Speed | Steps | | |
| Air Direction Control | Right, Left, Horizontal, Downward | | | |
| Air Filter | Removable, Washable | | | |
| Running Current (Rated) | A | 0.31 - 0.28 | | 0.30 - 0.27 |
| Power Consumption (Rated) | W | 57 - 57 | | 55 - 55 |
| Power Factor (Rated) | % | 88.4 - 88.7 | | 88.1 - 89.3 |
| Temperature Control | | Microcomputer Control | | |
| Dimensions (H × W × D) | in. (mm) | 11-5/8 × 39 × 10-3/8 (295 × 990 × 263) | | |
| Packaged Dimensions (H × W × D) | in. (mm) | 15-3/16 × 43-3/8 × 15-5/16 (386 × 1,102 × 389) | | |
| Weight (Mass) | lbs (kg) | 27 (13) | | |
| Gross Weight (Gross Mass) | lbs (kg) | 37 (17) | | |
| Sound Pressure Level | H / M / L / SL | 52 / 45 / 39 / 34 | | 49 / 43 / 38 / 34 |
| Outdoor Unit | | RXT24AVJU9 | | |
| Casing Color | | Ivory White | | |
| Heat Exchanger | Fin Spec / Tube | Waffle Fin (PE) / ϕ 7 Hi-XSL Tube | | |
| Compressor | Type | Hermetically Sealed Swing Type | | |
| | Model | 2Y260BPAX1A | | |
| Refrigerant Oil | Type | FW68DA | | |
| | Charge | oz (L) | 30.43 (0.90) | |
| Refrigerant | Type | R-32 | | |
| | Charge | lbs (kg) | 3.04 (1.38) | |
| Airflow Rate | cfm (m ³ /min) | 2,383 (67.5) | | 2,327 (65.9) |
| Fan | Type | Propeller | | |
| | Drive Input | A | | |
| Running Current (Rated) | A | 9.16 - 8.28 | | 11.05 - 10.00 |
| Power Consumption (Rated) | W | 1,810 - 1,810 | | 2,290 - 2,290 |
| Power Factor (Rated) | % | 95.0 - 95.0 | | 99.6 - 99.6 |
| Dimensions (H × W × D) | in. (mm) | 29-1/2 × 34-1/4 × 12-5/8 (750 × 870 × 320) | | |
| Packaged Dimensions (H × W × D) | in. (mm) | 32-1/16 × 40-5/16 × 16 (814 × 1,024 × 406) | | |
| Weight (Mass) | lbs (kg) | 127 (58) | | |
| Gross Weight (Gross Mass) | lbs (kg) | 135 (61) | | |
| Sound Pressure Level | dB(A) | 55 | | 57 |
| Conditions Based on | Indoor | 80.0°FDB (26.7°CDB) / 67.0°FWB (19.4°CWB) | | 70.0°FDB (21.1°CDB) / 60.0°FWB (15.6°CWB) |
| | Outdoor | 95.0°FDB (35.0°CDB) / 75.0°FWB (23.9°CWB) | | 47.0°FDB (8.33°CDB) / 43.0°FWB (6.11°CWB) |
| | Piping Length | 25 ft (7.5 m) | | |
| Drawing No. | 3D153395C | | | |
| Note | SL: The quiet fan level of the airflow rate setting. | | | |

| Conversion Formulae |
|----------------------------------|
| kcal/h = kW × 860 |
| Btu/h = kW × 3412 |
| cfm = m ³ /min × 35.3 |

Part 3 Printed Circuit Board Connector Wiring Diagram

| | |
|----------------------------|----|
| 1. Indoor Unit..... | 20 |
| 2. Outdoor Unit..... | 22 |
| 2.1 RXT09AVJU9 | 22 |
| 2.2 RXT12AVJU9 | 24 |
| 2.3 RXT15/18/24AVJU9 | 25 |

1. Indoor Unit

Control PCB (A1P)

- | | | |
|-----|------|--|
| 1) | S1 | Connector for terminal strip |
| 2) | S6 | Connector for swing motor (horizontal blade) |
| 3) | S91 | Connector for humidity sensor PCB (A4P) |
| 4) | S200 | Connector for DC fan motor |
| 5) | S403 | Connector for optional adaptor |
| 6) | S430 | Connector for wireless LAN connection PCB (A3P) |
| 7) | S501 | Connector for indoor heat exchanger thermistor (R1T) |
| 8) | S800 | Connector for display/signal receiver PCB (A2P) |
| 9) | FG | Connector for terminal strip (frame ground) |
| 10) | FU1 | Fuse (3.15 A, 250 V) |
| 11) | V2 | Varistor |

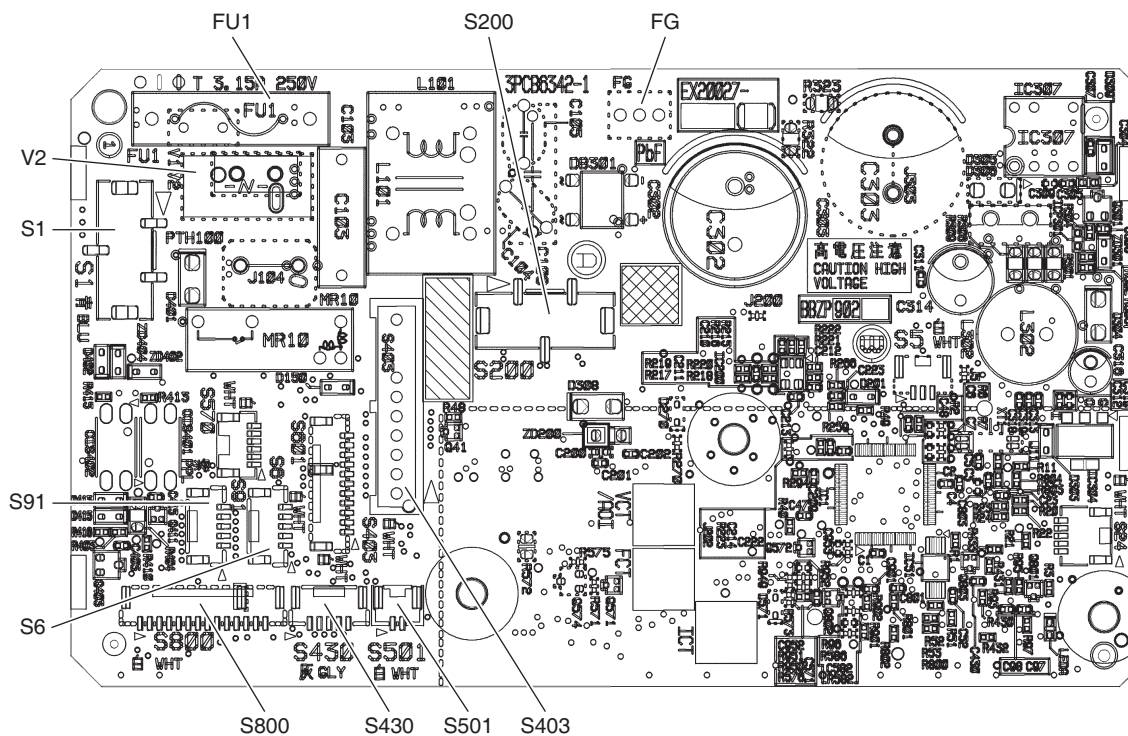

2P721387-10
2P721387-11

Display/Signal Receiver PCB (A2P)

- 1) S27 Connector for control PCB (A1P)
- 2) SW1 Indoor unit **ON/OFF** switch
- 3) LED1 LED for operation (green)
- 4) LED2 LED for timer (orange)
- 5) LED3 LED for wireless LAN connection (orange)

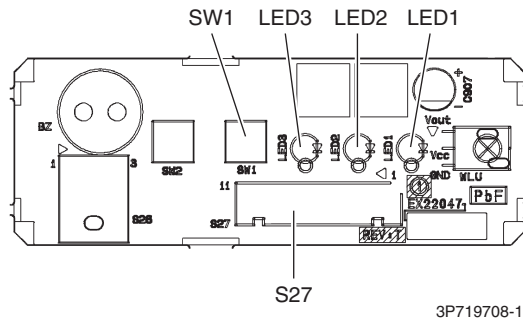

Wireless LAN connection PCB (A3P)

- 1) S90 Connector for control PCB (A1P)

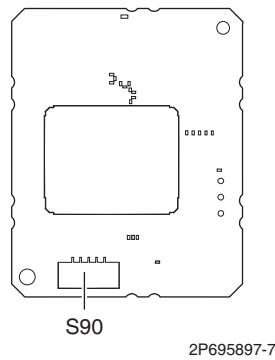

Humidity sensor PCB (A4P)

- 1) CON1 Connector for control PCB (A1P)

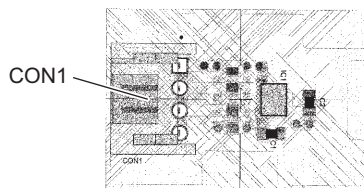

3E860031-1

2. Outdoor Unit

2.1 RXT09AVJU9

Main PCB (A1P)

| | | |
|-----|-----------------------|--|
| 1) | X100A | Connector for terminal strip |
| 2) | S | Faston tab for terminal strip |
| 3) | X200A | Connector for DC fan motor |
| 4) | X650A | Connector for compressor |
| 5) | X700A | Connector for electronic expansion valve coil |
| 6) | X800A | Connector for four way valve coil |
| 7) | X820A | Connector for overload protector and high pressure switch |
| 8) | X900A | Connector for thermistors (outdoor temperature, outdoor heat exchanger, discharge pipe) |
| 9) | E1 | Faston tab for ground |
| 10) | F1U | Fuse (20 A, 250 V) |
| 11) | F2U (F201UA) | Fuse (3.15 A, 250 V) |
| 12) | J5 | Jumper for warmer airflow setting Refer to page 139 for details. |
| 13) | J6 | Jumper for facility setting Refer to page 138 for details. |
| 14) | J9 | Jumper for drain pan heater Refer to page 140 for details. |
| 15) | LED | LED for service monitor (green) |
| 16) | R1V (V1), R2V (V2) | Varistor |

2.2 RXT12AVJU9

Main PCB (A1P)

- | | | |
|-----|--------------------------------------|--|
| 1) | LA, N, S | Faston tab for terminal strip |
| 2) | X10A | Connector for ground |
| 3) | X21A | Connector for electronic expansion valve coil |
| 4) | X30A | Connector for compressor |
| 5) | X40A | Connector for overload protector and high pressure switch |
| 6) | X70A | Connector for DC fan motor |
| 7) | X80A | Connector for four way valve coil |
| 8) | X90A | Connector for thermistors (outdoor temperature, outdoor heat exchanger, discharge pipe) |
| 9) | F1U | Fuse (30 A, 250 V) |
| 10) | F31U, F401U | Fuse (3.15 A, 250 V) |
| 11) | J5 | Jumper for warmer airflow setting Refer to page 139 for details. |
| 12) | J7 | Jumper for facility setting Refer to page 138 for details. |
| 13) | J9 | Jumper for drain pan heater Refer to page 140 for details. |
| 14) | LED | LED for service monitor (green) |
| 15) | R1V (V1), R2V (V2), R3V (V551) | Varistor |

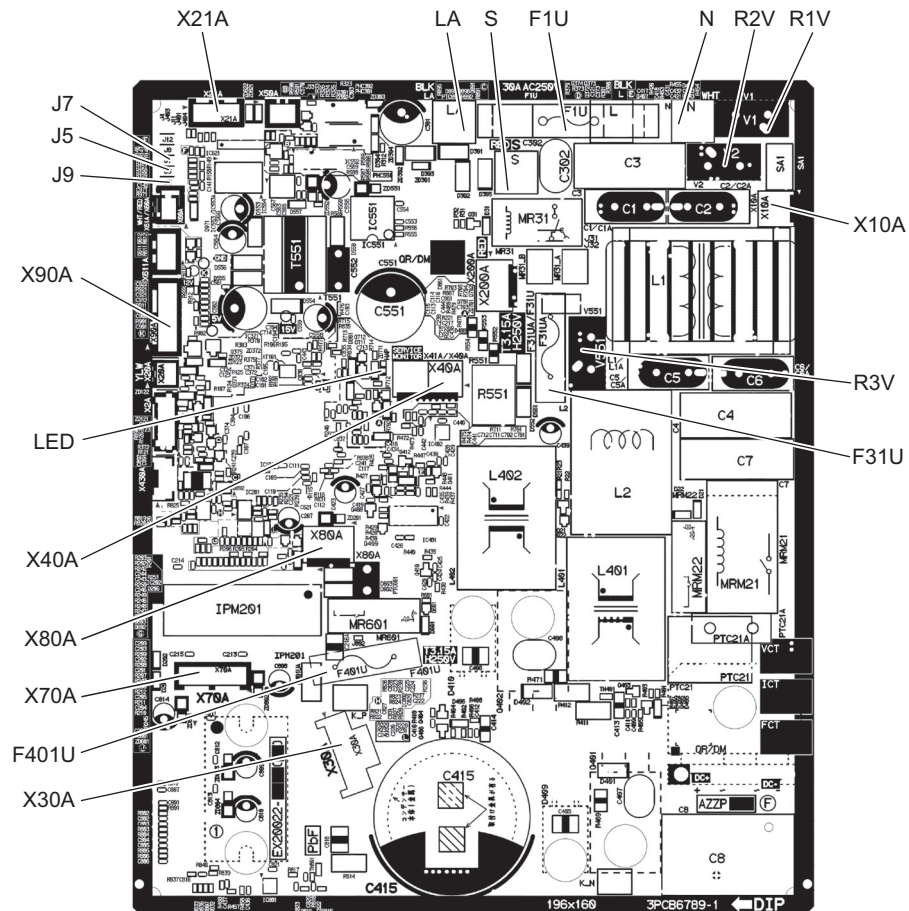

2P707243-20



Note

The symbols in the parenthesis are the names written on the PCB.

2.3 RXT15/18/24AVJU9

Main PCB (A1P)

- | | | |
|-----|-------------------------|--|
| 1) | X190A | Connector for ground wire |
| 2) | X200A | Connector for DC fan motor |
| 3) | X700A | Connector for electric expansion valve coil |
| 4) | X800A | Connector for four way valve coil |
| 5) | X820A | Connector for overload protector and high pressure switch |
| 6) | X900A | Connector for thermistors (outdoor temperature, outdoor heat exchanger, discharge pipe) |
| 7) | S, HL1, HN1 | Faston tab for terminal strip |
| 8) | U, V, W | Faston tab for compressor |
| 9) | DP1, DP2 | Faston tab for drain pan heater |
| 10) | F1U (FU1), F2U (FU2) | Fuse (3.15 A, 250 V) |
| 11) | F3U (FU3) | Fuse (30 A, 250 V) |
| 12) | J5 | Jumper for warmer airflow setting Refer to page 139 for details. |
| 13) | J7 | Jumper for facility setting Refer to page 138 for details. |
| 14) | J9 | Jumper for drain pan heater Refer to page 140 for details. |
| 15) | LED | LED for service monitor (green) |

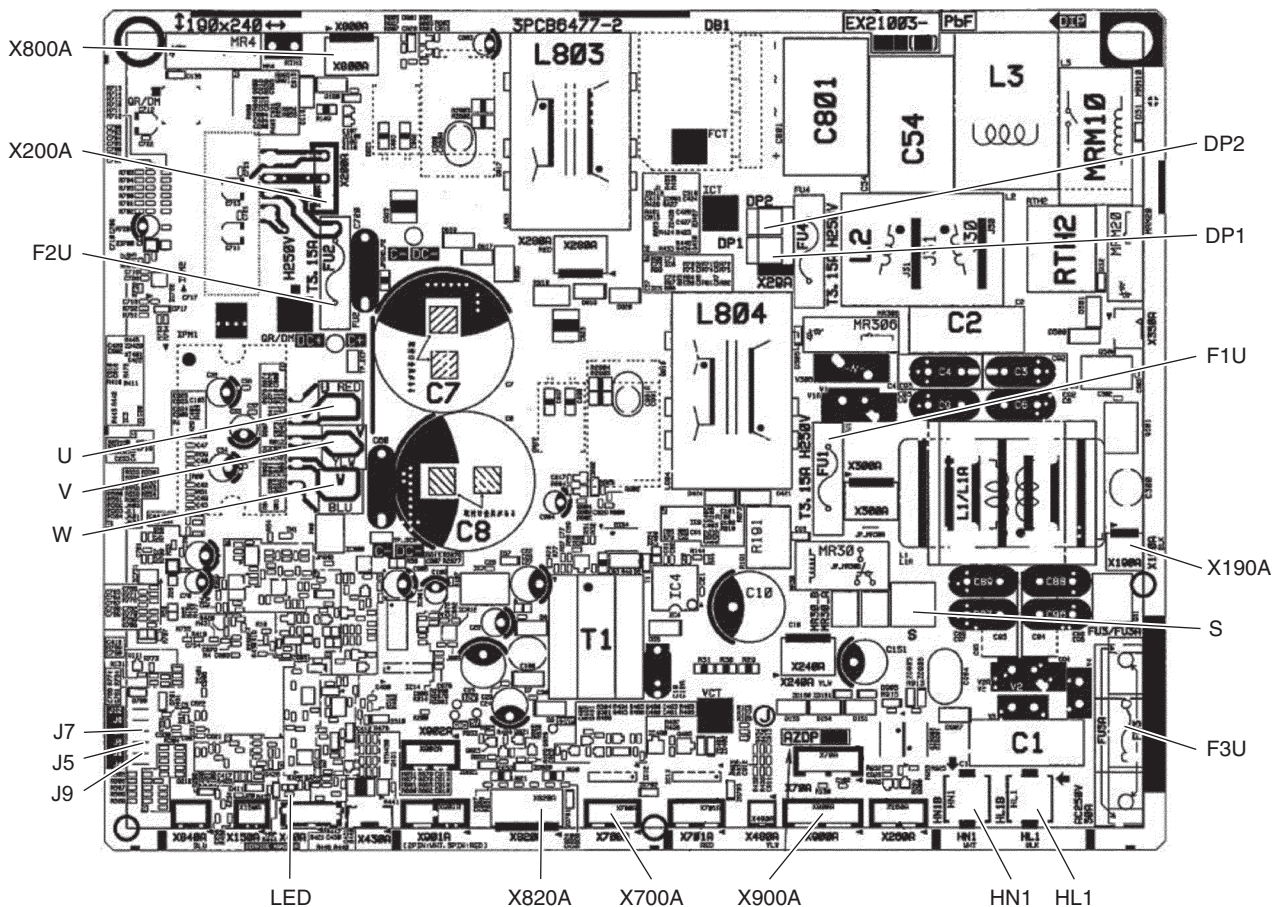

2P757473-6
2P757473-7



Note

The symbols in the parenthesis are the names written on the PCB.

Part 4

Functions and Control

| | |
|--|----|
| 1. Common Functions | 27 |
| 1.1 Temperature Control | 27 |
| 1.2 Frequency Principle | 27 |
| 1.3 Airflow Direction Control | 29 |
| 1.4 COMFORT AIRFLOW Operation | 30 |
| 1.5 Fan Speed Control for Indoor Unit | 31 |
| 1.6 Program Dry Operation | 32 |
| 1.7 Automatic Cooling/Heating Change-over | 33 |
| 1.8 Thermostat Control | 34 |
| 1.9 NIGHT SET Mode | 35 |
| 1.10 ECONO Operation | 35 |
| 1.11 POWERFUL Operation | 36 |
| 1.12 Brightness Setting of Indoor Unit Display | 37 |
| 1.13 Wireless LAN Connection | 38 |
| 1.14 Other Functions | 42 |
| 2. Thermistor Functions | 43 |
| 3. Control Specification | 44 |
| 3.1 Mode Hierarchy | 44 |
| 3.2 Frequency Control | 44 |
| 3.3 Controls at Mode Changing/Start-up | 46 |
| 3.4 Discharge Pipe Temperature Control | 48 |
| 3.5 Input Current Control | 49 |
| 3.6 High Pressure Protection Control | 50 |
| 3.7 Freeze-up Protection Control | 50 |
| 3.8 Heating Peak-cut Control | 51 |
| 3.9 Outdoor Fan Control | 52 |
| 3.10 Liquid Compression Protection Function | 52 |
| 3.11 Defrost Control | 53 |
| 3.12 Electronic Expansion Valve Control | 54 |
| 3.13 Malfunctions | 57 |

1. Common Functions

1.1 Temperature Control

Definitions of Temperatures

The definitions of temperatures are classified as following.

- Room temperature: temperature of lower part of the room
- Set temperature: temperature set by remote controller
- Room thermistor temperature: temperature detected by room temperature thermistor
- Target temperature: temperature determined by microcomputer

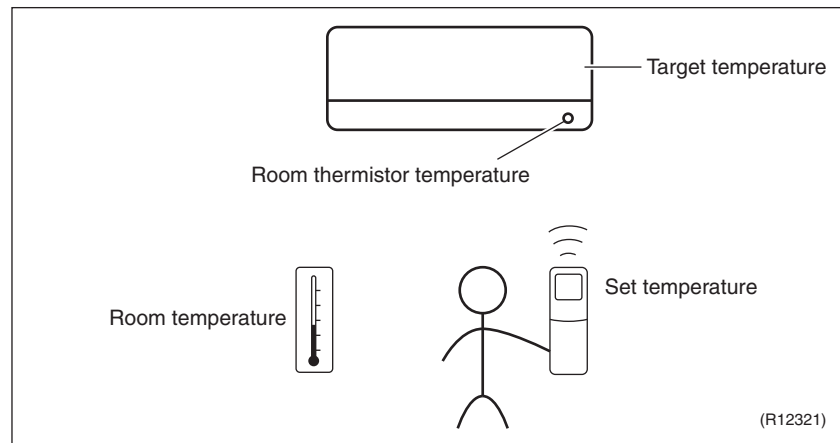

★ The illustration is for wall mounted type as representative.

Temperature Control

The temperature of the room is detected by the room temperature thermistor. However, there is a difference between the temperature detected by room temperature thermistor and the temperature of lower part of the room, depending on the type of the indoor unit or installation condition. In practice, the temperature control is done by the target temperature appropriately adjusted for the indoor unit and the temperature detected by room temperature thermistor.

1.2 Frequency Principle

Control Parameters

The frequency of the compressor is controlled by the following 2 parameters:

- The load condition of the operating indoor unit
- The difference between the room thermistor temperature and the target temperature

The target frequency is adapted by additional parameters in the following cases:

- Frequency restrictions
- Initial settings
- Forced cooling operation

Inverter Principle

To regulate the capacity, a frequency control is needed. The inverter makes it possible to control the rotation speed of the compressor. The followings explain the inverter principle:

Phase 1

The supplied AC power source is converted into the DC power source for the present.

Phase 2

The DC power source is reconverted into the three phase AC power source with variable frequency.

- When the frequency increases, the rotation speed of the compressor increases resulting in an increase of refrigerant circulation. This leads to a larger amount of heat exchange per unit.

- When the frequency decreases, the rotation speed of the compressor decreases resulting in a decrease of refrigerant circulation. This leads to a smaller amount of heat exchange per unit.

The following drawing shows a schematic view of the inverter principle:

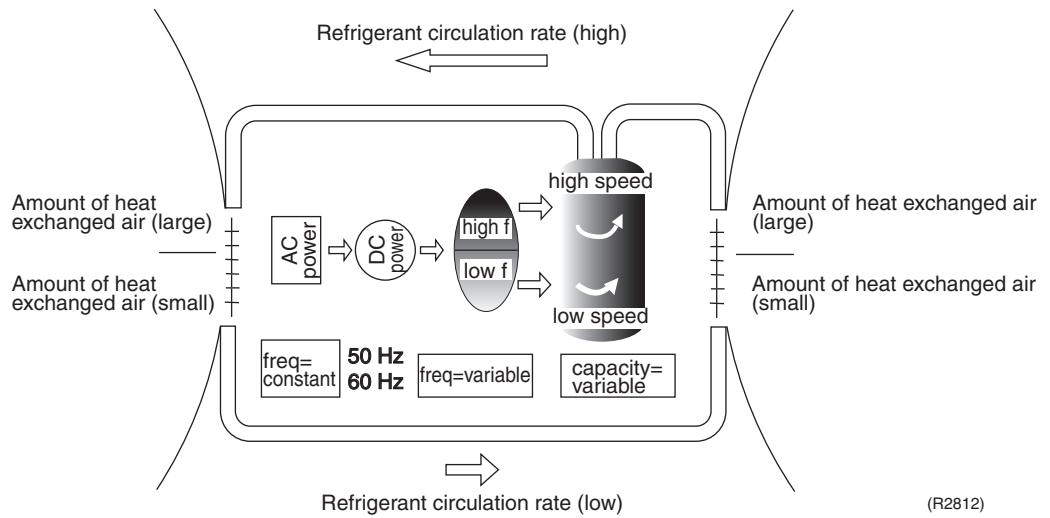

Inverter Features

The inverter provides the following features:

- The regulating capacity can be changed according to the changes in the outdoor temperature and cooling/heating load.
- Quick heating and quick cooling
The rotation speed of the compressor is increased when starting the heating (cooling). This enables to reach the set temperature quickly.
- Even during extreme cold weather, high capacity is achieved. It is maintained even when the outdoor temperature is 2°C (35.6°F).
- Comfortable air conditioning
A fine adjustment is integrated to keep the room temperature constant.
- Energy saving heating and cooling
Once the set temperature is reached, the energy saving operation enables to maintain the room temperature at low power.

Frequency Limits

The following functions regulate maximum frequency:

Low frequency

- Four way valve operation compensation. Refer to page 47.

High frequency

- Compressor protection function. Refer to page 47.
- Discharge pipe temperature control. Refer to page 48.
- Input current control. Refer to page 49.
- Freeze-up protection control. Refer to page 50.
- Heating peak-cut control. Refer to page 51.
- Defrost control. Refer to page 53.

Forced Cooling Operation

Refer to page 131 for details.

1.3 Airflow Direction Control

Power-Airflow (Dual) Flap(s)

The large flap sends a large volume of air downward to the floor and provides an optimum control in cooling, dry and heating operation.

Cooling/Dry

During cooling or dry operation, the flap retracts into the indoor unit. Then, cool air can be blown far and distributed all over the room.

Heating

During heating operation, the large flap directs airflow downward to spread the warm air to the entire room.

Wide-Angle Louvers

The louvers, made of elastic synthetic resin, provide a wide range of airflow that guarantees comfortable air distribution.

Auto-Swing

The following tables explain the auto-swing process for cooling, dry, heating and fan:

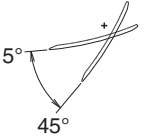
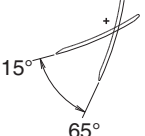
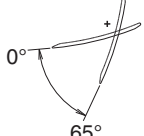
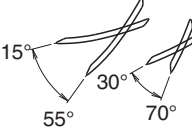
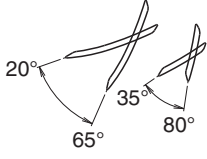
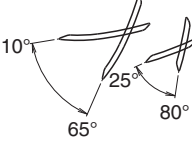
| | Flap (up and down) | | |
|-------------------|---|--|---|
| | Cooling/Dry | Heating | Fan |
| 09/12 class |  R4004115 |  (R21049) |  (R21050) |
| 15/18/24 class |  (R21651) |  (R21652) |  (R21653) |

1.4 COMFORT AIRFLOW Operation

Outline

The flow of air will be in the upward direction while in COOL/DRY operation and in the downward direction while in HEAT operation, which will provide a comfortable wind that will not come in direct contact with people.

Operation

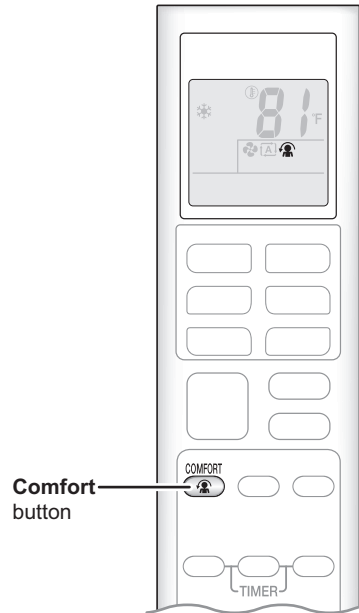

To start the operation:

- Press **Comfort** button.

The icon appears on the LCD of the remote controller.

| | | | |
|-----------------|----------------------|----------------|---------------|
| | COOL / DRY operation | HEAT operation | FAN operation |
| Flaps direction | Goes up | Goes down | Not available |
| Airflow rate | AUTO | | |

To stop the operation:

- Press **Comfort** button again.

The icon disappears from the LCD of the remote controller. The flaps will return to the memorized position before the start of COMFORT AIRFLOW operation



Note(s)

- POWERFUL operation and COMFORT AIRFLOW operation cannot be used at the same time.
- The airflow rate will be set to AUTO.
- If the upward and downward airflow direction is selected, the COMFORT AIRFLOW function will be canceled. Priority is given to the function of whichever button is pressed last.

1.5 Fan Speed Control for Indoor Unit

Outline

Phase control and fan speed control contains 9 steps: LLL, LL, SL, L, ML, M, MH, H, and HH. The airflow rate can be automatically controlled depending on the difference between the room thermistor temperature and the target temperature.

Automatic Fan Speed Control

In automatic fan speed operation, the step SL is not available.

| Step | Cooling | Heating |
|---------------|---------|---------|
| LLL | ↕ | ↕ |
| LL | | |
| L | | |
| ML | | |
| M | | |
| MH | | |
| H | | |
| HH (POWERFUL) | | |

↕ = The airflow rate is automatically controlled within this range when **FAN** setting button is set to automatic. R4003512

■ Cooling

The following drawing explains the principle of fan speed control for cooling.

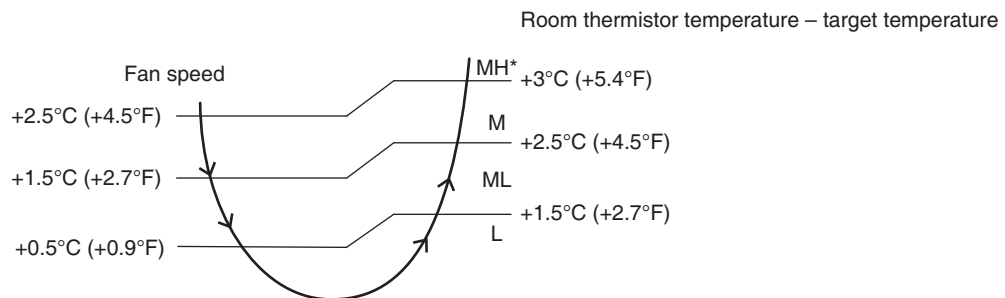

* The upper limit is at M tap in 30 minutes from the operation start. R4004133

■ Heating

In heating operation, the fan speed is regulated according to the indoor heat exchanger temperature and the difference between the room thermistor temperature and the target temperature.



Note(s)

The fan stops during defrost operation.

1.6 Program Dry Operation

Outline Program dry operation removes humidity while preventing the room temperature from lowering. Since the microcomputer controls both the temperature and airflow rate, the temperature adjustment and **FAN** setting buttons are inoperable.

Details The microcomputer automatically sets the temperature and airflow rate. The difference between the room thermistor temperature at start-up and the target temperature is divided into two zones. Then, the unit operates in an appropriate capacity for each zone to maintain the temperature and humidity at a comfortable level.

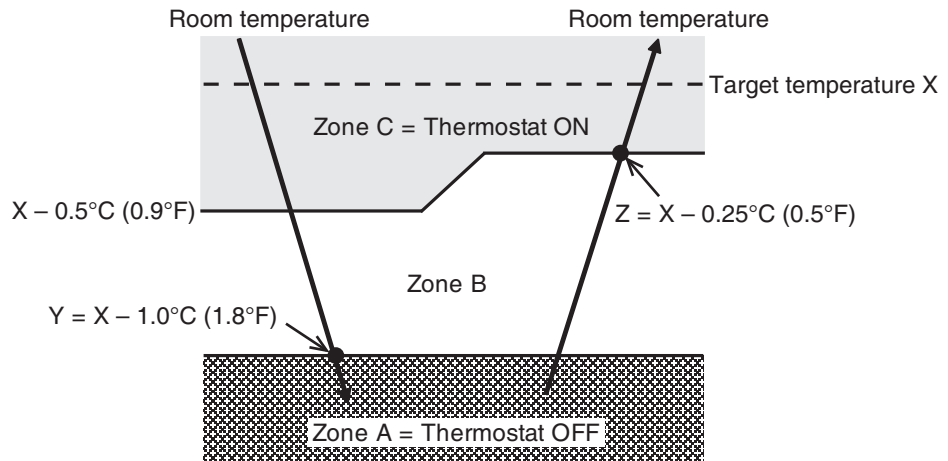

R4004134

| Room thermistor temperature at start-up | Target temperature X | Thermostat OFF point Y | Thermostat ON point Z ★ |
|---|---|---------------------------|--|
| 24°C or more (75.2°F or more) | Room thermistor temperature at start-up | X - 1.0°C (X - 1.8°F) | X - 0.25°C (X - 0.5°F) |
| 18 ~ 23.5°C (64.4 ~ 74.3°F) | | X - 0.75°C (X - 1.4°F) | X - 0.25°C (X - 0.5°F) |
| 17.5°C or less (63.5°F or less) | 18°C (64.4°F) | X - 0.75°C (X - 1.4°F) | X - 0.25°C = 17.75°C (X - 0.5°F = 63.9°F) |

★ Thermostat turns on also when the room temperature is in the zone B for 10 minutes.

1.7 Automatic Cooling/Heating Change-over

Outline

When the automatic operation is selected with the remote controller, the microcomputer automatically determines the operation mode as cooling or heating according to the room temperature and the set temperature at start-up.

The unit automatically switches the operation mode to maintain the room temperature at the set temperature.

Details

Ts: set temperature (set by remote controller)

Tt: target temperature (determined by microcomputer)

Tr: room thermistor temperature (detected by room temperature thermistor)

C: correction value

- The set temperature (Ts) determines the target temperature (Tt).
(Ts = 18 ~ 30°C (64.4 ~ 86°F))
- The target temperature (Tt) is calculated as;
Tt = Ts + C
where C is the correction value.
C = 0°C (0°F)
- Thermostat ON/OFF point and operation mode switching point are as follows.
 - Heating → Cooling switching point:
Tr ≥ Tt + 3.0°C (+ 5.4°F)
 - Cooling → Heating switching point:
Tr < Tt - 2.5°C (- 4.5°F)
 - Thermostat ON/OFF point is the same as the ON/OFF point of cooling or heating operation.
- During initial operation
Tr ≥ Ts : Cooling operation
Tr < Ts : Heating operation

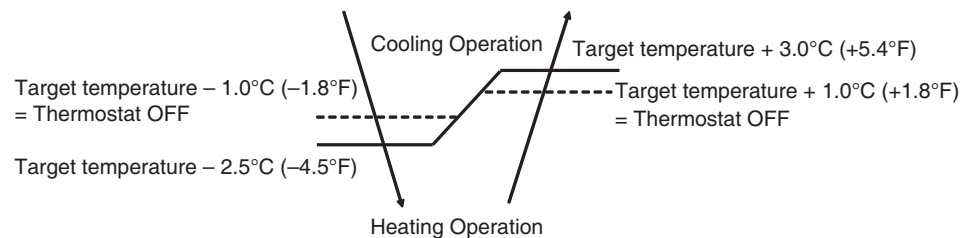

R4004135

Ex: When the target temperature is 25°C (77°F)

Cooling → 24°C (75.2°F): Thermostat OFF → 22.5°C (72.5°F): Switch to heating

Heating → 26°C (78.8°F): Thermostat OFF → 28°C (82.4°F): Switch to cooling

1.8 Thermostat Control

Outline Thermostat control is based on the difference between the room thermistor temperature and the target temperature.

- Details**
- Thermostat OFF Conditions**
- The temperature difference is in the zone A.
- Thermostat ON Conditions**
- The temperature difference returns to the zone C after being in the zone A.
 - The system resumes from defrost control in any zones except A.
 - The operation turns on in any zones except A.
 - The monitoring time has passed while the temperature difference is in the zone B.

| Cooling | Dry | Heating |
|------------|-------------|-------------|
| 10 minutes | 7.5 minutes | 180 seconds |

Cooling/Dry

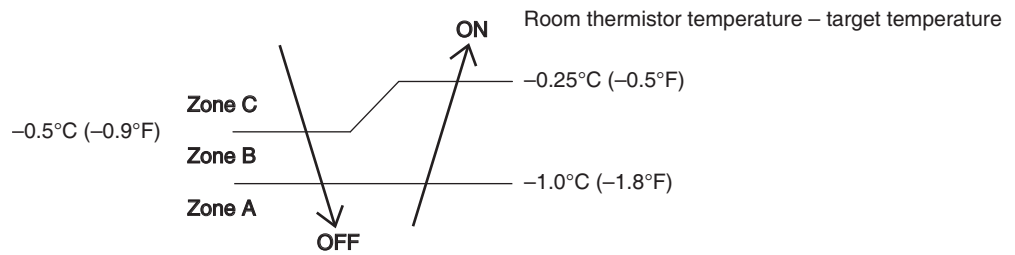

R4004136

Heating

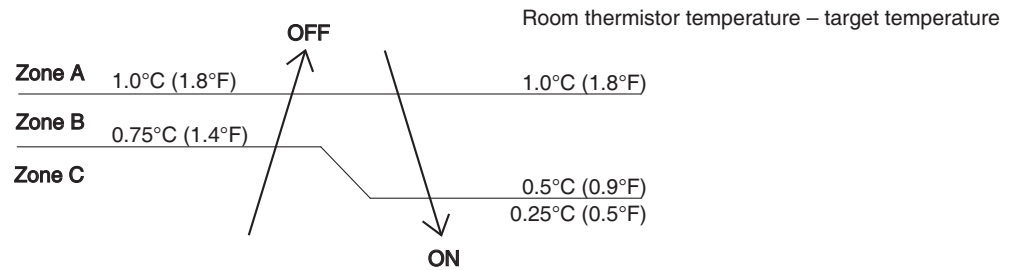

R4004137



Reference

Refer to Temperature Control on page 27 for details.

1.9 NIGHT SET Mode

Outline

When the OFF TIMER is set, NIGHT SET mode is automatically activated. NIGHT SET mode keeps the airflow rate setting.

Details

NIGHT SET mode continues operation at the target temperature for the first one hour, then automatically raises the target temperature slightly in the case of cooling, or lowers the target temperature slightly in the case of heating. This prevents excessive cooling in summer and excessive heating in winter to ensure comfortable sleeping conditions, and also conserves electricity.

Cooling

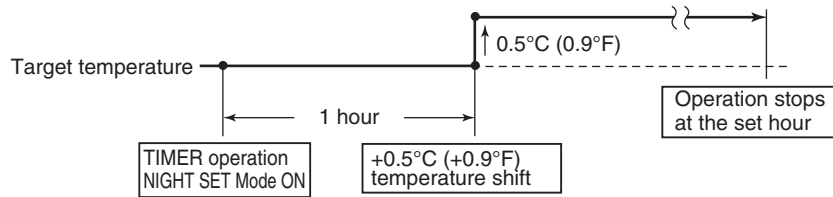

(R23917)

Heating

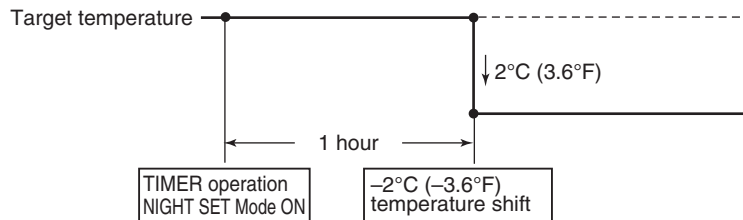

(R23918)

1.10 ECONO Operation

Outline

ECONO operation reduces the maximum operating current and the power consumption. This operation is particularly convenient for energy-saving. It is also a major bonus when breaker capacity does not allow the use of multiple electrical devices and air conditioners. It can be easily activated by pressing **ECONO** button on the wireless remote controller.

Details

- When this function is activated, the maximum capacity also decreases.
- The remote controller can send the ECONO command when the unit is in cooling, heating, dry, or automatic operation. This function can only be set when the unit is running. Pressing **ECONO** button on the remote controller cancels the function.
- This function and POWERFUL operation cannot be used at the same time. The latest command has the priority.

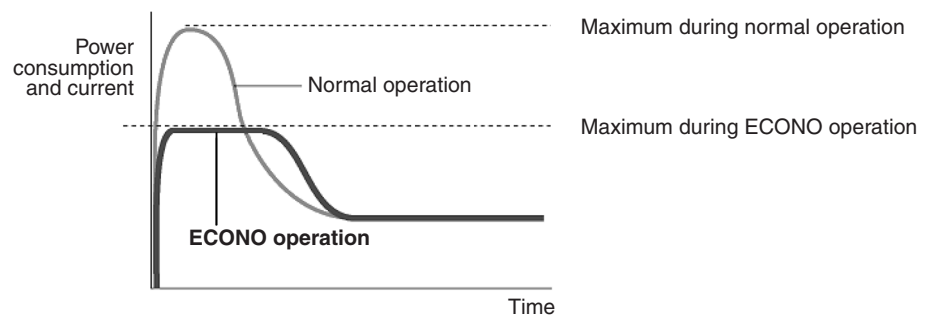

(R22012)

1.11 POWERFUL Operation

Outline

In order to exploit the cooling and heating capacity to full extent, the air conditioner can be operated by increasing the indoor fan rotating speed and the compressor frequency.

Details

When **POWERFUL** button is pressed, the fan speed and target temperature are converted to the following states for 20 minutes.

| Operation mode | Fan speed | Target temperature |
|----------------|---|---|
| COOL | H tap + A rpm | 18°C (64.4°F) |
| DRY | Dry rotating speed + A rpm | Lowered by 2.5°C (4.5°F) |
| HEAT | H tap + A rpm | 31°C (87.8°F) |
| FAN | H tap + A rpm | — |
| AUTO | Same as cooling/heating in POWERFUL operation | The target temperature is kept unchanged. |

A = 40 ~ 80 rpm (depending on the model)

Ex: POWERFUL operation in cooling

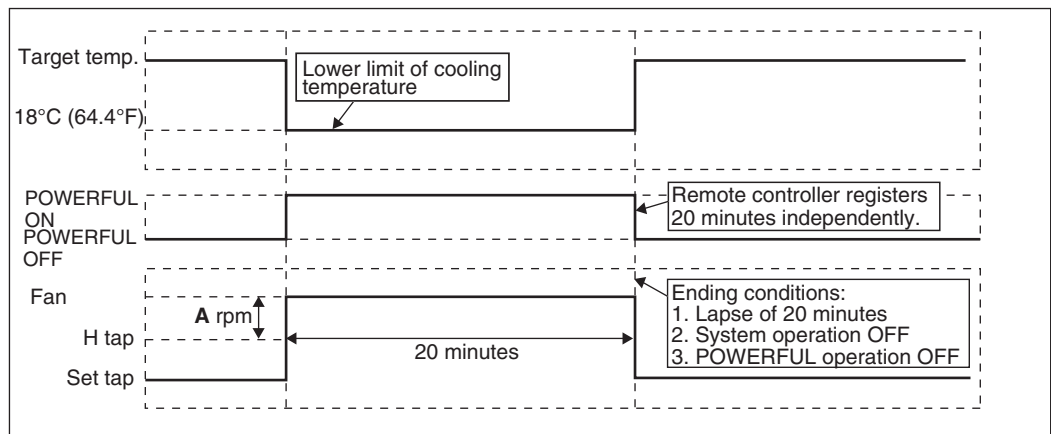

(R24589)



Note(s)

- During POWERFUL operation, the cooling/heating efficiency of the other rooms may be slightly reduced.
- POWERFUL operation cannot be used together with ECONO, COMFORT AIRFLOW operation.

1.12 Brightness Setting of Indoor Unit Display

Outline

The brightness of the indoor unit display can be adjusted as desired. Also, the display can be turned OFF.

Details

1. Press and hold **FAN** button for 5 seconds.
2. Press **TEMP ▲** button to select menu number 1.
LED appears and 1 blinks.

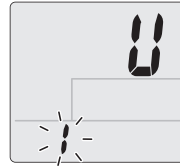

3. Press **FAN** button to confirm the select setting.
4. Press **TEMP ▲** or **TEMP ▼** button to change the setting as follows:

R4004121

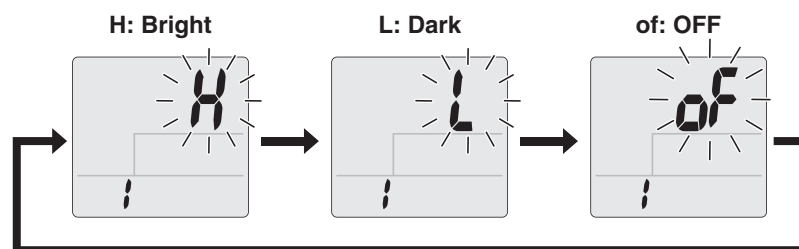

R4004122

5. Press **FAN** button again. Brightness will be set to the chosen value.
6. Press and hold **FAN** button for 5 seconds to return to the default screen.



Note(s)

The display automatically returns to the default screen after 60 seconds. To return to the default screen sooner, press **CANCEL** button twice.

1.13 Wireless LAN Connection

Operation

Wireless LAN connection adapter

The Wireless LAN connection adapter function requires the Daikin One Home for connecting to the air conditioner and controlling it via your smartphone or tablet over your network.

Attention

- **Wireless LAN sends and receives data using radio waves so there is a risk of transmitted data being subject to eavesdropping and illegal access. When using wireless LAN, manage the SSID/KEY of the wireless LAN connection adapter, the SSID/KEY of the wireless router, and the app login information so that they will not be known to others, and ensure that you have an adequate understanding of the risks involved. In the case that the product is accessed and operated illegally, turn off the wireless LAN connection adapter function.**
 - **Do not use this product near a microwave oven. (This can affect wireless LAN communications.)**
 - **This product cannot be directly connected to the communication line of a telecommunications carrier (internet service provider, etc.). When connecting to the internet, be sure to connect via a device such as a router.**
- When the wireless LAN connection adapter function is turned on, the right side of the air conditioner may become slightly warm, but this is not an abnormality.

WARNING

- While the Wireless LAN connection adapter operates, it may affect persons using cardiac pacemakers or defibrillators. This product may cause electromagnetic interference.
- While the Wireless LAN connection adapter operates, it may affect automatic doors or fire alarm equipment. This product may cause faulty behavior of the equipment.

Configuration

- The user is responsible for providing the following items before using this product:
 - Smartphone or tablet PC
 - Internet line and communicating device (Modem/router or similar device)
 - Wireless LAN access point
 - Application name: [Daikin One Home] (free)
- For details on the installation method for the Daikin One Home.

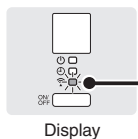

Wireless LAN connection adapter lamp (Orange)

- The Wireless LAN connection adapter lamp lights when connecting to a router (Wireless LAN access point).
- For Wireless LAN connection adapter operation.

WARNING

When operating an air conditioner from outside the home, it is not possible to check the air conditioner or the surroundings of the air conditioner, or the state of the people in the room. Therefore, make sure to adequately check for safety before use.

In some cases, there is a risk of death, severe injury, or property damage.

- **Check the following in advance (while at home)**
 - Timer settings or reservations that other users may have made. (There is a risk of causing harm to the health of people, animals, or plants in the home if operation starts and stops unexpectedly)
 - There are no signs of abnormality in the air conditioning. Harm will not be caused to people or to the room if there is a change in airflow. (For example, that there are no objects nearby that might blow over) (There is a risk of objects falling due to airflow and causing fire, bodily injury, or staining of household items)
 - **Check the following before/while operating a unit from outside the home**
 - If you know that there is someone at home, inform the person when turning the air conditioner on or off from outside the home. (If someone at home is standing on something such as a stool, the air conditioner turning on or off unexpectedly could surprise them and cause them to fall or topple over. Additionally, a sudden change in the indoor/outdoor temperature could harm the health of people at home)
 - The air conditioner can be turned off and temperature adjustment can be made using a remote controller in the home.
 - Do not use the function if the only people at home are persons who are unable to make adjustments to temperature or other settings themselves, such as young children, disabled persons, or elderly persons.
 - Regularly check the settings and operating status of the air conditioner. (Sudden changes in indoor/outdoor temperature pose a health hazard. There is a risk of harm to animals and plants)
- If an error occurs during operation, immediately turn off the air conditioner and contact your dealer.
Double check the display to confirm that the power is off.

Wireless LAN connection



Web site: <https://daikinone.com/ductless>

For instructions on how to connect your unit to wireless LAN and to your Daikin One Home application, please see the website above.

Contains FCC ID: VPYLB1YA

This device complies with part 15 of the FCC Rules. Operation is subject to the following two conditions:

- (1) This device may not cause harmful interference, and
- (2) This device must accept any interference received, including interference that may cause undesired operation.

FCC CAUTION

Changes or modifications not expressly approved by the party responsible for compliance could void the user's authority to operate the equipment. This transmitter must not be co-located or operated in conjunction with any other antenna or transmitter.

Contains IC: 772C-LB1YA

This device complies with Industry Canada's applicable licence-exempt RSSs.

Operation is subject to the following two conditions:

- (1) This device may not cause interference; and
- (2) This device must accept any interference, including interference that may cause undesired operation of the device.

This equipment complies with IC radiation exposure limits set forth for an uncontrolled environment and meets RSS-102 of the IC radio frequency (RF) Exposure rules. This equipment should be installed and operated keeping the radiator at least 7-7/8 inches (20cm) or more away from person's body.

The FCC responsible party is Daikin Comfort Technologies Manufacturing, L.P., and may be contacted by calling (713)-861-2500, or at 19001 Kermier Rd., Waller, TX 77484.

(<https://www.northamerica-daikin.com>)

This device, which was assembled by Daikin Comfort Technologies Manufacturing, L.P., contains a component that is classified as an intentional radiator.

This intentional radiator has been certified by the FCC: FCC ID VPYLB1YA.

And this intentional radiator has an industry Canada ID: IC 772C-LB1YA.

The manufacturer of the intentional radiator (model no. Type1YA) is Murata Manufacturing co., Ltd (www.murata.com).

This equipment complies with FCC radiation exposure limits set forth for an uncontrolled environment and meets the FCC radio frequency (RF) Exposure Guidelines. This equipment should be installed and operated keeping the radiator at least 7-7/8 inches (20cm) or more away from person's body.

Changes or modifications not expressly approved by the party responsible for compliance could void the user's authority to operate the equipment.

NOTE: This equipment has been tested and found to comply with the limits for a Class B digital device, pursuant to part 15 of the FCC Rules. These limits are designed to provide reasonable protection against harmful interference in a residential installation. This equipment generates, uses and can radiate radio frequency energy and, if not installed and used in accordance with the instructions, may cause harmful interference to radio communications. However, there is no guarantee that interference will not occur in a particular installation. If this equipment does cause harmful interference to radio or television reception, which can be determined by turning the equipment off and on, the user is encouraged to try to correct the interference by one or more of the following measures:

- Reorient or relocate the receiving antenna.
- Increase the separation between the equipment and receiver.
- Connect the equipment into an outlet on a circuit different from that to which the receiver is connected.
- Consult the dealer or an experienced radio/TV technician for help.

Application software installation

For Android Phones

- 1) Open [Google Play].
- 2) Search using the application name:
[Daikin One Home].
- 3) Follow the directions on the screen to install.

For iOS Phones

- 1) Open the [App Store].
- 2) Search using the application name:
[Daikin One Home].
- 3) Follow the directions on the screen to install.

Attention

- The actual application screen layout and content may differ from what is shown. The layout and content of the application screen is subject to change without notice.

Connect the air conditioner to your home network.

1. While operation is stopped, press  and hold the button for 5 seconds.

2. Press  or  and select menu number **3**.

- “SP” appears on the LCD.
- “3” blinks.

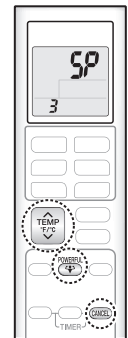

3. Press  to connect to the access point.

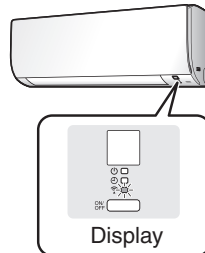



The wireless LAN connection adapter lamp blinks quickly.

4. Press  to return to the default screen.
No more settings need to be carried out from the remote controller.

5. Open Daikin One Home App and follow the instructions to set up the wireless LAN.

6. When the wireless LAN connection adapter lamp switches from blinking to lit, the connection is complete.

NOTE

- While “SP” is displayed, the options that can be selected using  and  are 1, 3, A, and OFF.
- Perform wireless LAN connection one indoor unit at a time.
- If you are unable to establish a network connection, refer the troubleshooting provided by the Daikin One Home App.
- When the lamp blinks slowly, the connection is not ready. Perform the connection procedure while it blinks quickly.

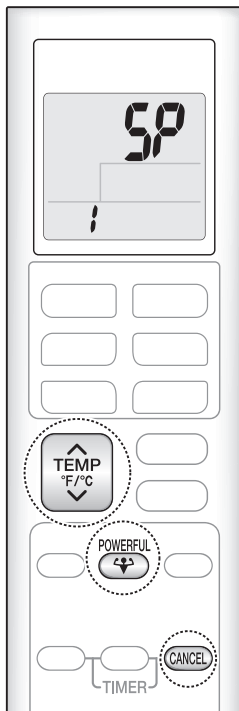

To confirm the wireless LAN connection adapter connection

■ To confirm

1. While operation is stopped, press and hold the button for 5 seconds.
2. Press to confirm the selected setting.

- “SP” appears on the LCD.
- “!” blinks.

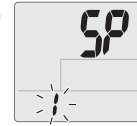

Check the indoor unit LED.

| Wireless LAN connection adapter lamp | Status |
|--------------------------------------|---|
| Blinking for 1 second | Connection is not ready |
| Blinking for 3 seconds | Please initialize the wireless LAN connection adapter |
| Does not blink or light | Communication is abnormal There is a possibility of equipment failure Please request repair |

To turn off the wireless connection

■ To use the remote controller

1. While operation is stopped, press and hold the button for 5 seconds.

2. Press or and select menu OFF.

- “SP” appears on the LCD.
- “OFF” blinks, and communication is OFF.



3. Press and hold the button for 2 seconds to confirm selected setting.

- The wireless LAN connection adapter lamp turn off.

4. Press to return to the default screen.

To reset the connection setting to the factory default

- If you want to reset the connection settings, it is possible to initialize the wireless LAN connection adapter to its factory default state. If initialized, data including the network settings and power consumption history will be erased.
- When discarding or transferring to another user, initialize the connection adapter to erase the internal data.

■ To reset

1. While operation is stopped, press and hold the button for 5 seconds.

2. Press or and select menu R.

- “SP” appears on the LCD.
- “R” blinks.

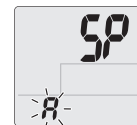

3. Press and hold the button for 2 seconds to confirm selected setting.

- The wireless LAN connection adapter lamp blinks for 1 second.

4. Press to return to the default screen.

1.14 Other Functions

1.14.1 Hot-Start Function

In order to prevent the cold air blast that normally occurs when heating operation is started, the temperature of the indoor heat exchanger is detected, and the airflow is either stopped or significantly weakened resulting in comfortable heating.



Note(s)

The cold air blast is prevented using similar control when defrost control starts or when the thermostat is turned ON.

1.14.2 Signal Receiving Sign

When the indoor unit receives a signal from the remote controller, the unit emits a signal receiving sound.

1.14.3 Indoor Unit ON/OFF Switch

ON/OFF switch is provided on the display of the unit.

- Press **ON/OFF** switch once to start operation. Press once again to stop it.
- **ON/OFF** switch is useful when the remote controller is missing or the battery has run out.

| Operation mode | Temperature setting | Airflow rate |
|----------------|---------------------|--------------|
| AUTO | 25°C (77°F) | Automatic |

■ **09/12 class**

■ **15/18/24 class**

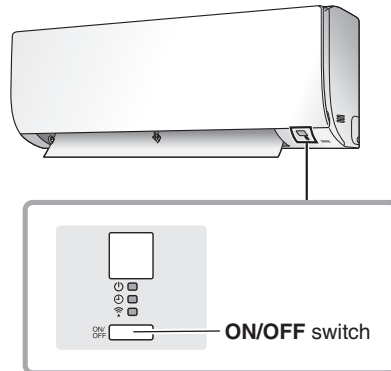

R4004127

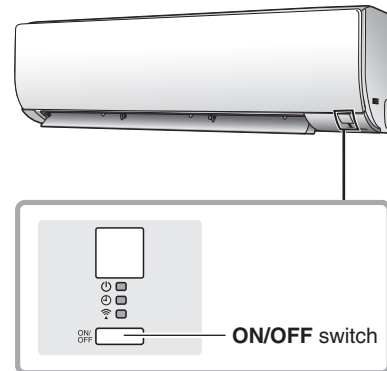

R4004128

1.14.4 Auto-restart Function

If a power failure (even a momentary one) occurs during the operation, the system restarts automatically in the same conditions as before when the power supply is restored to the conditions prior to the power failure.



Note

It takes 3 minutes to restart the operation because 3-minute standby function is activated.

2. Thermistor Functions

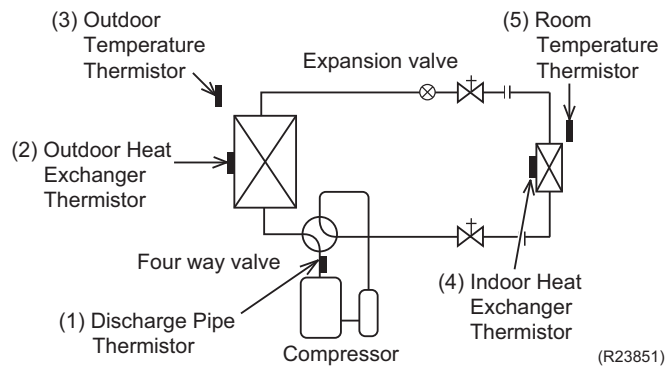

(1) Discharge Pipe Thermistor

- The discharge pipe thermistor is used for controlling discharge pipe temperature. If the discharge pipe temperature (used in place of the inner temperature of the compressor) rises abnormally, the operating frequency becomes lower or the operation halts.
- The discharge pipe thermistor is used for detecting disconnection of the discharge pipe thermistor.

(2) Outdoor Heat Exchanger Thermistor

- The outdoor heat exchanger thermistor is used for controlling the target discharge pipe temperature. The system sets the target discharge pipe temperature according to the outdoor and indoor heat exchanger temperature, and controls the electronic expansion valve opening so that the target discharge pipe temperature can be obtained.
- In cooling operation, the outdoor heat exchanger thermistor is used for detecting the disconnection of the discharge pipe thermistor. When the discharge pipe temperature drops below the outdoor heat exchanger temperature by more than a certain value, the discharge pipe thermistor is judged as disconnected.
- In cooling operation, the outdoor heat exchanger thermistor is used for high pressure protection.

(3) Outdoor Temperature Thermistor

- The outdoor temperature thermistor detects the outdoor air temperature and is used for refrigerant shortage detection, input current control, outdoor fan control, liquid compression protection function, and so on.

(4) Indoor Heat Exchanger Thermistor

- The indoor heat exchanger thermistor is used for controlling the target discharge pipe temperature. The system sets the target discharge pipe temperature according to the outdoor and indoor heat exchanger temperature, and controls the electronic expansion valve opening so that the target discharge pipe temperature can be obtained.
- In cooling operation, the indoor heat exchanger thermistor is used for freeze-up protection control. If the indoor heat exchanger temperature drops abnormally, the operating frequency becomes lower or the operation halts.
- In heating operation, the indoor heat exchanger thermistor is used for detecting the disconnection of the discharge pipe thermistor. When the discharge pipe temperature drops below the indoor heat exchanger temperature by more than a certain value, the discharge pipe thermistor is judged as disconnected.

(5) Room Temperature Thermistor

- The room temperature thermistor detects the room air temperature and is used for controlling the room air temperature.

3. Control Specification

3.1 Mode Hierarchy

Outline

The air conditioner control has normal operation mode, forced operation mode, and power transistor test mode for installation and servicing.

Details

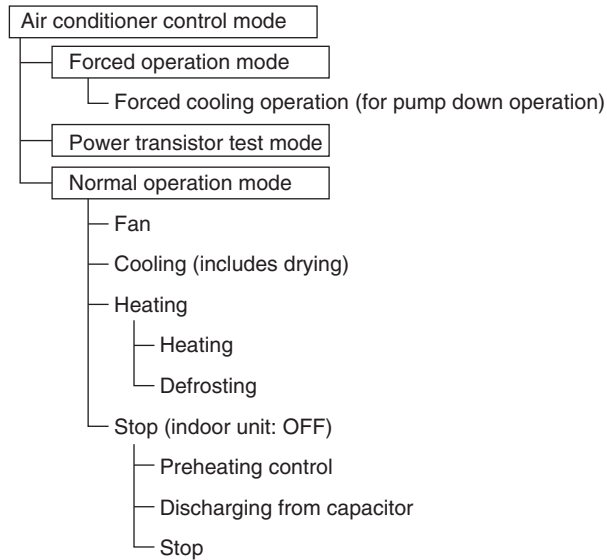

(R22375)

- Unless specified otherwise, dry operation command is regarded as cooling operation.

3.2 Frequency Control

Outline

The compressor frequency is determined according to the difference between the room thermistor temperature and the target temperature.

When the shift of the frequency is less than zero ($\Delta F < 0$) by PI control, the target frequency is used as the command frequency.

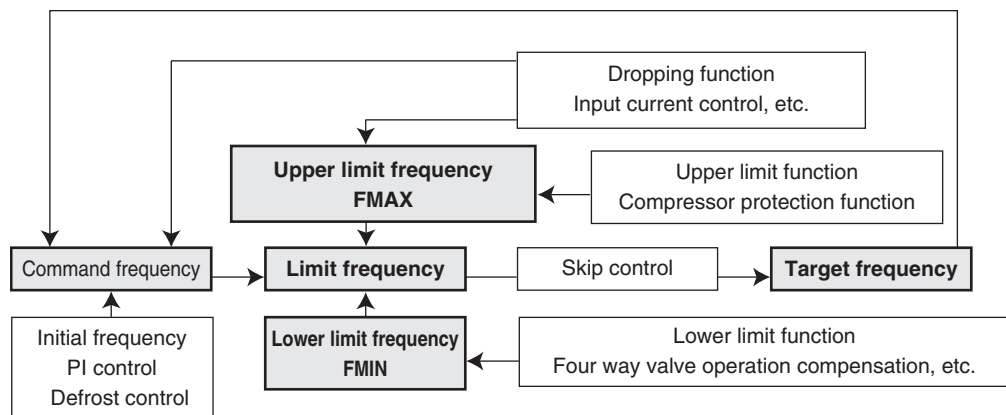

(R18023)

Details

1. Determine command frequency

Command frequency is determined in the following order of priority.

- (1) Limiting defrost control time
- (2) Forced cooling
- (3) Indoor frequency command

2. Determine upper limit frequency

The minimum value is set as an upper limit frequency among the frequency upper limits of the following functions:

Compressor protection, input current, discharge pipe temperature, heating peak-cut, freeze-up protection, defrost control.

3. Determine lower limit frequency

The maximum value is set as a lower limit frequency among the frequency lower limits of the following functions:

Four way valve operation compensation, draft prevention, pressure difference upkeep.

4. Determine prohibited frequency

There is a certain prohibited frequency such as a power supply frequency.

Initial Frequency

When starting the compressor, the frequency is initialized according to the ΔD value of the indoor unit.

 ΔD signal: Indoor frequency command

The difference between the room thermistor temperature and the target temperature is taken as the ΔD value and is used for ΔD signal of frequency command.

| Temperature difference | ΔD signal | Temperature difference | ΔD signal | Temperature difference | ΔD signal | Temperature difference | ΔD signal |
|------------------------|-------------------|------------------------|-------------------|------------------------|-------------------|------------------------|-------------------|
| -2.0°C (-3.6°F) | *OFF | 0°C (0°F) | 4 | 2.0°C (3.6°F) | 8 | 4.0°C (7.2°F) | 12 |
| -1.5°C (-2.7°F) | 1 | 0.5°C (0.9°F) | 5 | 2.5°C (4.5°F) | 9 | 4.5°C (8.1°F) | 13 |
| -1.0°C (-1.8°F) | 2 | 1.0°C (1.8°F) | 6 | 3.0°C (5.4°F) | 10 | 5.0°C (9.0°F) | 14 |
| -0.5°C (-0.9°F) | 3 | 1.5°C (2.7°F) | 7 | 3.5°C (6.3°F) | 11 | 5.5°C (9.9°F) | 15 |

* OFF = Thermostat OFF

PI Control**1. P control**

The ΔD value is calculated in each sampling time (20 seconds), and the frequency is adjusted according to its difference from the frequency previously calculated.

2. I control

If the operating frequency does not change for more than a certain fixed time, the frequency is adjusted according to the ΔD value.

When ΔD value is low, the frequency is lowered.

When ΔD value is high, the frequency is increased.

3. Frequency control when other controls are functioning

- When frequency is dropping:
Frequency control is carried out only when the frequency drops.
- For limiting lower limit:
Frequency control is carried out only when the frequency rises.

4. Upper and lower limit of frequency by PI control

The frequency upper and lower limits are set according to the command of the indoor unit. When the indoor unit quiet or QUIET OUTDOOR UNIT operation command comes from the indoor unit, the upper limit frequency is lower than the usual setting.

3.3 Controls at Mode Changing/Start-up

3.3.1 Preheating Control

Outline The inverter operation in open phase starts with the conditions of the outdoor temperature, the discharge pipe temperature, the radiation fin temperature and the preheating command from the indoor unit.

Details

- ON condition
 - Discharge pipe temperature < **A**
 - Outdoor temperature < **B**
 - Radiation fin temperature < 85°C (185°F)
- OFF condition
 - Discharge pipe temperature > **C**
 - Outdoor temperature > **D**
 - Radiation fin temperature ≥ 90°C (194°F)

| | A | | B | | C | | D | |
|-------------|----------|------|----------|------|----------|------|----------|------|
| | (°C) | (°F) | (°C) | (°F) | (°C) | (°F) | (°C) | (°F) |
| 09 class | 2.5 | 36.5 | 0 | 32 | 4 | 39.2 | 2 | 35.6 |
| 12 class | 10 | 50 | 0 | 32 | 12 | 53.6 | 2 | 35.6 |
| 15 class | 13.5 | 56.3 | 0 | 32 | 15.5 | 59.9 | 0 | 32 |
| 18/24 class | 6.5 | 43.7 | 5 | 41 | 9 | 48.2 | 7 | 44.6 |

3.3.2 Four Way Valve Switching

Outline The four way valve coil is energized/not energized depending on the operation mode. (Heating: ON, Cooling/Dry/Defrost: OFF)
In order to eliminate the switching sound as the four way valve coil switches from ON to OFF when the heating is stopped, the OFF delay switch of the four way valve is carried out.

Details

OFF delay switch of four way valve
The four way valve coil is energized for 160* seconds after the operation is stopped.
*10 seconds in heating operation when the outdoor temperature is lower than -9 °C (15.8°F)

3.3.3 Four Way Valve Operation Compensation

Outline

At the beginning of operation as the four way valve is switched, the pressure difference to activate the four way valve is acquired when the output frequency is higher than a certain fixed frequency, for a certain fixed time.

Details

Starting Conditions

1. When the compressor starts and the four way valve switches from OFF to ON
2. When the four way valve switches from ON to OFF during operation
3. When the compressor starts after resetting
4. When the compressor starts after the fault of four way valve switching

The lower limit of frequency keeps **A** Hz for **B** seconds for any of the conditions above.

When the outdoor temperature is above **C** in heating, the frequency decreases depending on the outdoor temperature.

| | 09 class | | 12 class | | 15 class | | 18/24 class | |
|--------------------|----------|---------|----------|---------|----------|---------|-------------|---------|
| | Cooling | Heating | Cooling | Heating | Cooling | Heating | Cooling | Heating |
| A (Hz) | 44 | 54 | 28 | 34 | 48 | | 28 | 30 |
| B (seconds) | 50 | | 60 | | 70 | | 70 | |
| C | (°C) | 10 | 10 | 10 | 15 | | 20 | |
| | (°F) | 50 | 50 | 50 | 59 | | 68 | |

3.3.4 3-Minute Standby

Turning on the compressor is prohibited for 3 minutes after turning off.
The function is not used when defrosting.

3.3.5 Compressor Protection Function

When turning the compressor from OFF to ON, the upper limit of frequency is set as follows.
The function is not used when defrosting.

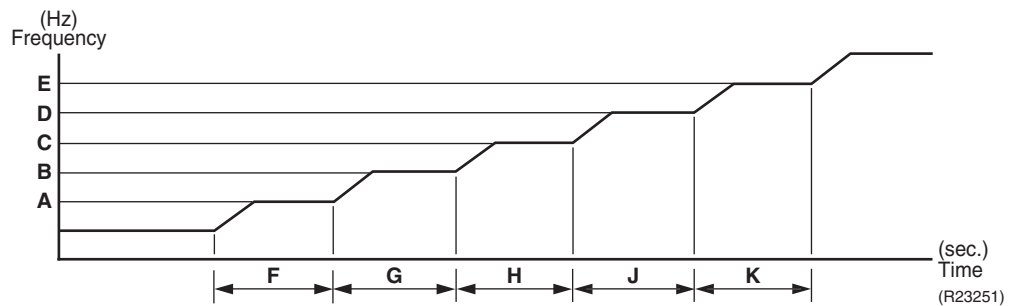

| | 09 class | 12 class | 15 class | 18/24 class |
|--------------------|----------|----------|----------|-------------|
| A (rps) | 40 | 36 | 52 | 30 |
| B (rps) | 54 | 48 | 68 | 48 |
| C (rps) | 72 | 68 | 80 | 62 |
| D (rps) | 90 | 80 | 98 | 80 |
| E (rps) | 112 | 110 | — | — |
| F (seconds) | 180 | 120 | 300 | 450 |
| G (seconds) | 420 | 420 | 200 | 450 |
| H (seconds) | 180 | 180 | 460 | 300 |
| J (seconds) | 300 | 180 | 200 | 470 |
| K (seconds) | 400 | 600 | — | — |

3.4 Discharge Pipe Temperature Control

Outline

The discharge pipe temperature is used as the internal temperature of the compressor. If the discharge pipe temperature rises above a certain level, the upper limit of frequency is set to keep the discharge pipe temperature from rising further.

Details

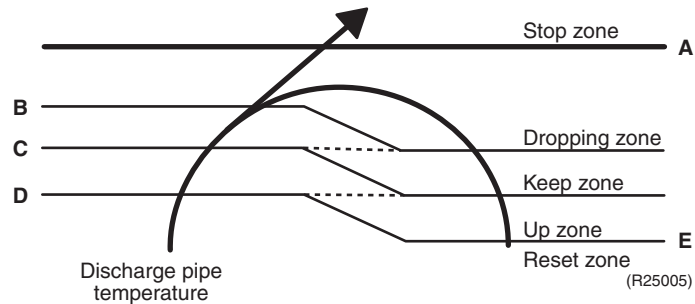

| Zone | Control |
|---------------|---|
| Stop zone | When the temperature reaches the stop zone, the compressor stops. |
| Dropping zone | The upper limit of frequency decreases. |
| Keep zone | The upper limit of frequency is kept. |
| Up zone | The upper limit of frequency increases. |
| Reset zone | The upper limit of frequency is canceled. |

| | 09 class | | 12 class | | 15/18/24 class | |
|----------|----------|-------|----------|-------|----------------|-------|
| | (°C) | (°F) | (°C) | (°F) | (°C) | (°F) |
| A | 110 | 230.0 | 118 | 244.4 | 118 | 244.4 |
| B | 103 | 217.4 | 105 | 221.0 | 108 | 226.4 |
| C | 98 | 208.4 | 98 | 208.4 | 103 | 217.4 |
| D | 93 | 199.4 | 91 | 195.8 | 97 | 206.6 |
| E | 88 | 190.4 | 79 | 174.2 | 85 | 185.0 |

3.5 Input Current Control

Outline

The microcomputer calculates the input current while the compressor is running, and sets the frequency upper limit based on the input current.

In case of heat pump models, this control is the upper limit control of the frequency and takes priority over the lower limit control of four way valve operation compensation.

Details

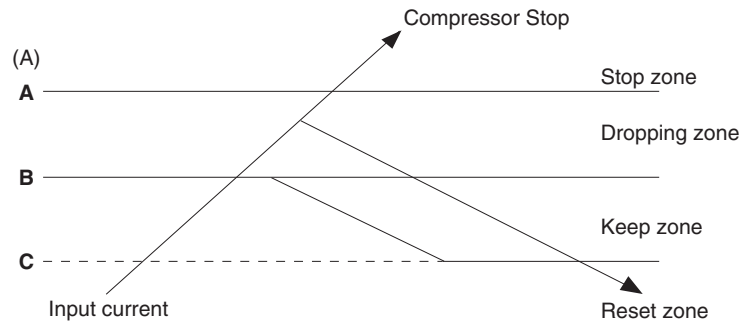

(R23249)

Frequency control in each zone

Stop zone

- After the input current remains in the stop zone for 2.5 seconds, the compressor is stopped.

Dropping zone

- The upper limit of the compressor frequency is defined as operation frequency – 2 Hz.
- After this, the output frequency is lowered by 2 Hz every second until it reaches the keep zone.

Keep zone

- The present maximum frequency goes on.

Reset zone

- Limit of the frequency is canceled.

| | 09 class | | 12 class | | 15 class | |
|--------------|----------|---------|----------|---------|----------|---------|
| | Cooling | Heating | Cooling | Heating | Cooling | Heating |
| A (A) | 12 | | 13 | 14 | 18 | |
| B (A) | 7.5 | 10.5 | 8.25 | 13.25 | 12 | 14.5 |
| C (A) | 6.5 | 9.5 | 7.5 | 12.5 | 11 | 13.5 |

| | 18 class | | 24 class | |
|--------------|----------|---------|----------|---------|
| | Cooling | Heating | Cooling | Heating |
| A (A) | 20 | | 20 | |
| B (A) | 16.25 | 19 | 16.25 | 19.25 |
| C (A) | 15.25 | 18 | 15.25 | 18.25 |

Limitation of current dropping and stop value according to the outdoor temperature

- ◆ The current drops when outdoor temperature becomes higher than a certain level (depending on the model).

3.6 High Pressure Protection Control

Outline

In order to prevent abnormal high pressures in the system and hence avoiding activation of the high pressure safety device the below control function will be activated.

Details

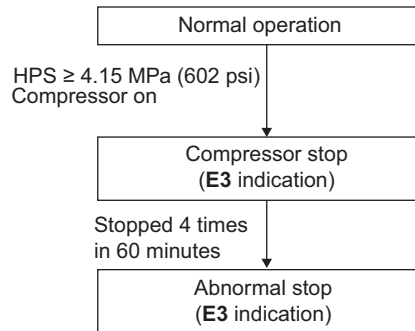
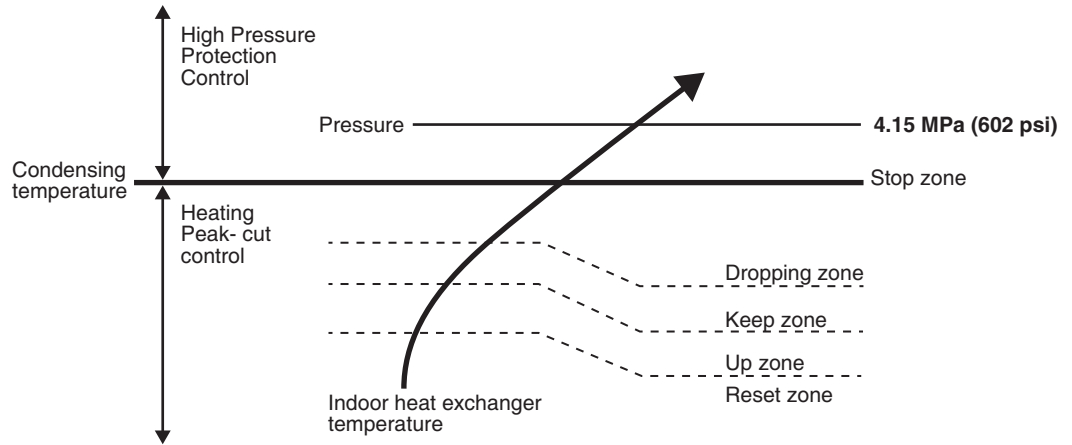

3.7 Freeze-up Protection Control

Outline

During cooling operation, the signal sent from the indoor unit determines the frequency upper limit and prevents freezing of the indoor heat exchanger. The signals from the indoor unit are divided into zones.

Details

The operating frequency limitation is judged with the indoor heat exchanger temperature.

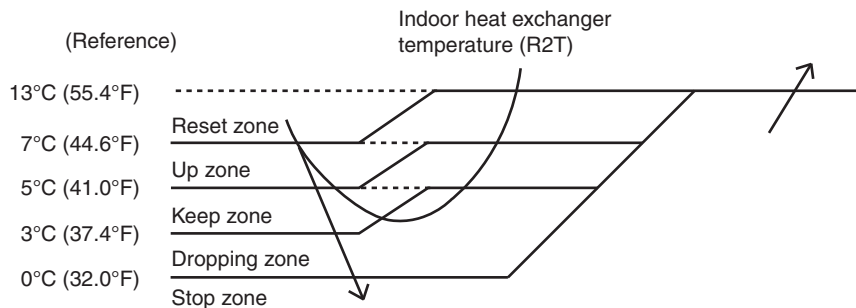

R4003644

3.8 Heating Peak-cut Control

During heating operation, the indoor heat exchanger temperature determines the frequency upper limit to prevent abnormal high pressure.

The operating frequency limitation is judged with the indoor heat exchanger temperature.

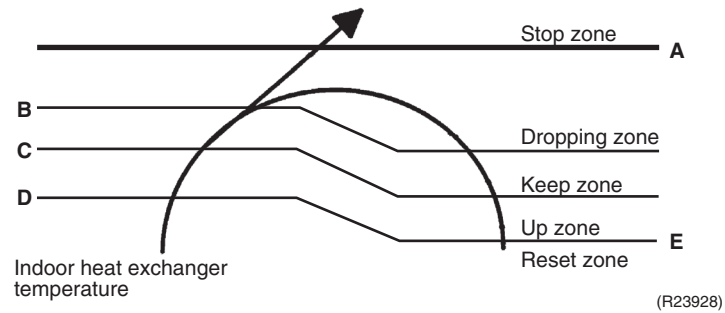

| Zone | Control |
|---------------|---|
| Stop zone | When the temperature reaches the stop zone, the compressor stops. |
| Dropping zone | The upper limit of frequency decreases. |
| Keep zone | The upper limit of frequency is kept. |
| Up zone | The upper limit of frequency increases. |
| Reset zone | The upper limit of frequency is canceled. |

| | 09 class | | 12 class | | 15/18/24 class | |
|------------|----------|-------|----------|-------|----------------|-------|
| | (°C) | (°F) | (°C) | (°F) | (°C) | (°F) |
| A | 59 | 138.2 | 59 | 138.2 | 59 | 138.2 |
| B ★ | 55 | 131.0 | 54 | 129.2 | 55 | 131.0 |
| C ★ | 52 | 125.6 | 51 | 123.8 | 52 | 125.6 |
| D ★ | 50 | 122.0 | 48 | 118.4 | 50 | 122.0 |
| E | 45 | 113.0 | 44 | 111.2 | 45 | 113.0 |

★: The valves might drop when the outdoor temperature is low to protect the compressor.

3.9 Outdoor Fan Control

1. **Fan ON control to cool down the electrical box**
The outdoor fan is turned ON when the electrical box temperature is high while the compressor is OFF.
2. **Fan OFF control during defrosting**
The outdoor fan is turned OFF while defrosting.
3. **Fan OFF delay when stopped**
The outdoor fan is turned OFF 60 ~ 70 seconds after the compressor stops.
4. **Fan speed control for pressure difference upkeep**
The rotation speed of the outdoor fan is controlled for keeping the pressure difference during cooling operation with low outdoor temperature.
 - When the pressure difference is low, the rotation speed of the outdoor fan is reduced.
 - When the pressure difference is high, the rotation speed of the outdoor fan is controlled as well as normal operation.
5. **Fan speed control during forced operation**
The outdoor fan is controlled as well as normal operation during forced operation.
6. **Fan speed control during POWERFUL operation**
The rotation speed of the outdoor fan is increased during POWERFUL operation.
7. **Fan speed control during indoor unit quiet/QUIET OUTDOOR UNIT operation**
The rotation speed of the outdoor fan is reduced by the command of the indoor unit quiet/QUIET OUTDOOR UNIT operation.
8. **Fan ON/OFF control when operation (cooling, heating, dry) starts/stops**
The outdoor fan is turned ON when the operation starts. The outdoor fan is turned OFF when the operation stops.

3.10 Liquid Compression Protection Function

Outline

The compressor stops according to the outdoor temperature for protection.

Details

Operation stops depending on the outdoor temperature.

The compressor turns off under the conditions that the system is in cooling operation and the outdoor temperature is below 0°C (32°F).

However, the operating range can be extended to the lowest temperature of -20°C (-4°F) by changing facility setting. Refer to page 138 for details of facility setting.

3.11 Defrost Control

Outline

Defrosting is carried out by the cooling cycle (reverse cycle). The defrosting time or outdoor heat exchanger temperature must be more than a certain value to finish defrosting.

Details

Conditions for Starting Defrost

- The starting conditions are determined with the outdoor temperature and the outdoor heat exchanger temperature.
- The system is in heating operation.
- The compressor operates for 6 minutes.
- More than **A** minutes (depending on the duration of the previous defrost control) of accumulated time have passed since the start of the operation, or ending the previous defrosting.

Conditions for Canceling Defrost

The judgment is made with the outdoor heat exchanger temperature (**B**).

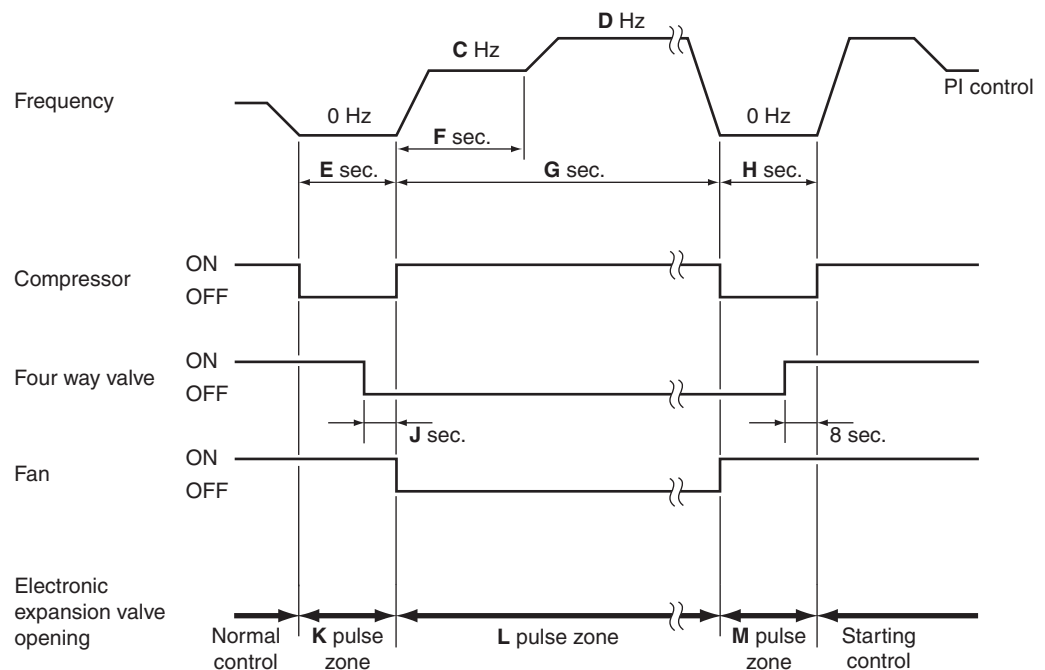

(R21661)

| | 09 class | 12 class | 15 class | 18/24 class |
|--------------------|----------|-------------|-------------|-------------|
| A (minute) | 20 ~ 25 | 20 ~ 25 | 44 | 48 |
| B | (°C) | 2 ~ 12 | 2 ~ 13 | 6 ~ 12 |
| | (°F) | 35.6 ~ 53.6 | 35.6 ~ 55.4 | 42.8 ~ 53.6 |
| C (Hz) | 58 | 40 | 52 | 48 |
| D (Hz) | 74 | 40 | 90 | 62 |
| E (seconds) | 40 | 40 | 60 | 40 |
| F (seconds) | 60 | 60 | 60 | 60 |
| G (seconds) | 690 | 720 | 630 | 460 |
| H (seconds) | 50 | 50 | 90 | 80 |
| J (seconds) | 8 | 8 | 8 | 8 |
| K (pulse) | 410 | 400 | 256 | 288 |
| L (pulse) | 350 | 350 | 120 ~ 200 | 320 |
| M (pulse) | 400 | 400 | 288 | 256 |

3.12 Electronic Expansion Valve Control

Outline

The following items are included in the electronic expansion valve control.

Electronic expansion valve is fully closed

1. Electronic expansion valve is fully closed when turning on the power.
2. Pressure equalizing control

Open Control

1. Electronic expansion valve control when starting operation
2. Electronic expansion valve control when the frequency changes
3. Electronic expansion valve control for defrosting
4. Electronic expansion valve control when the discharge pipe temperature is abnormally high
5. Electronic expansion valve control when the discharge pipe thermistor is disconnected

Feedback Control

Target discharge pipe temperature control

Details

The followings are the examples of electronic expansion valve control for each operation mode.

| Control | Status | | | | | | | |
|---|----------------------------|-----------------|---|--|--|---|--|------------------------|
| | Power on ; Compressor stop | Operation start | Frequency change under starting control | During target discharge pipe temperature control | Frequency change under target discharge pipe temperature control | Discharge pipe thermistor disconnection | Frequency change under discharge pipe thermistor disconnection control | During defrost control |
| Starting operation control | — | ● | — | — | — | — | — | — |
| Control when the frequency changes | — | — | ● | — | ● | — | — | — |
| Target discharge pipe temperature control | — | — | — | ● | — | — | — | — |
| Discharge pipe thermistor disconnection control | — | — | — | — | — | ● | ● | — |
| High discharge pipe temperature control | — | ● | ● | ● | ● | — | — | — |
| Defrost control (heating only) | — | — | — | — | — | — | — | ● |
| Pressure equalizing control | ● | — | — | — | — | — | — | — |
| Opening limit control | — | ● | ● | ● | ● | ● | ● | — |

- : Available
- : Not available

R4003560

3.12.1 Initialization as Power Supply On

The electronic expansion valve is initialized (fully closed) when the power is turned on. Then, the valve opening position is set and the pressure is equalized.

3.12.2 Pressure Equalizing Control

When the compressor is stopped, the pressure equalizing control is activated. The electronic expansion valve opens, and develops the pressure equalization.

3.12.3 Opening Limit Control

The maximum and minimum opening of the electronic expansion valve are limited.

| | 09/12 class | 15 class | 18/24 class |
|-------------------------|-------------|----------|-------------|
| Maximum opening (pulse) | 470 | 480 | 490 |
| Minimum opening (pulse) | 60 | 40 | 40 |

The electronic expansion valve is fully closed when cooling operation stops, and is opened at a fixed degree during defrosting.

3.12.4 Starting Operation Control

The electronic expansion valve opening is controlled when the operation starts, thus preventing superheating or liquid compression.

3.12.5 Control when the Frequency Changes

When the target discharge pipe temperature control is active, if the target frequency changes to a specified value in a certain time period, the target discharge pipe temperature control is canceled and the target opening of the electronic expansion valve is changed according to the frequency shift.

3.12.6 High Discharge Pipe Temperature Control

When the compressor is operating, if the discharge pipe temperature exceeds a certain value, the electronic expansion valve opens and the refrigerant runs to the low pressure side. This procedure lowers the discharge pipe temperature.

3.12.7 Discharge Pipe Thermistor Disconnection Control

Outline

The disconnection of the discharge pipe thermistor is detected by comparing the discharge pipe temperature with the condensation temperature. If the discharge pipe thermistor is disconnected, the electronic expansion valve opens according to the outdoor temperature and the operation frequency, operates for a specified time, and then stops.

After 3 minutes, the operation restarts and checks if the discharge pipe thermistor is disconnected. If the discharge pipe thermistor is disconnected, the system stops after operating for a specified time.

If the disconnection is detected repeatedly, the system is shut down. When the compressor runs for 60 minutes without any error, the error counter is reset.

Details

Determining thermistor disconnection

When the starting control finishes, the detection timer for disconnection of the discharge pipe thermistor (**A** seconds) starts. When the timer is over, the following adjustment is made.

1. When the operation mode is cooling

When the following condition is fulfilled, the discharge pipe thermistor disconnection is ascertained.

Discharge pipe temperature $+6^{\circ}\text{C}$ ($+10.8^{\circ}\text{F}$) $<$ outdoor heat exchanger temperature

2. When the operation mode is heating

When the following condition is fulfilled, the discharge pipe thermistor disconnection is ascertained.

Discharge pipe temperature $+6^{\circ}\text{C}$ ($+10.8^{\circ}\text{F}$) $<$ indoor heat exchanger temperature

| | A (seconds) | | |
|---|--------------------|----------|-------------|
| | 09/12 class | 15 class | 18/24 class |
| Other than below | 720 | 540 | 1020 |
| Heating (When outdoor temperature is below -15°C (5°F)) | 1200 | 1800 | 1800 |

When the thermistor is disconnected

When the disconnection is ascertained, the compressor continues operation for 9 minutes and then stops.

If the compressor stops repeatedly, the system is shut down.

3.12.8 Target Discharge Pipe Temperature Control

The target discharge pipe temperature is obtained from the indoor and outdoor heat exchanger temperature, and the electronic expansion valve opening is adjusted so that the actual discharge pipe temperature becomes close to the target discharge pipe temperature. (Indirect SH (superheating) control using the discharge pipe temperature)

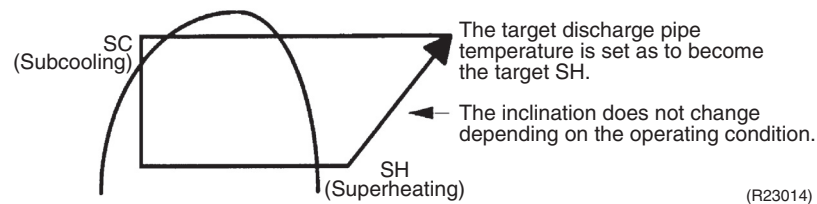

The electronic expansion valve opening and the target discharge pipe temperature are adjusted every **A** seconds. The opening degree of the electronic expansion valve is adjusted by the following.

- Target discharge pipe temperature
- Actual discharge pipe temperature
- Previous discharge pipe temperature

| | 09 class | 12 class | 15/18/24 class |
|--------------------|----------|----------|----------------|
| A (seconds) | 10 ~ 30★ | 10 ~ 20★ | 20 |

★ The time depends on the opening of the electronic expansion valve.

3.13 Malfunctions

3.13.1 Sensor Malfunction Detection

Sensor malfunction can be detected in the following thermistor:

1. Outdoor heat exchanger thermistor
2. Discharge pipe thermistor
3. Radiation fin thermistor
4. Outdoor temperature thermistor

3.13.2 Detection of Overcurrent and Overload

Outline

An excessive output current is detected and the OL temperature is observed to protect the compressor.

Details

- If the OL (compressor head) temperature exceeds 120 ~ 130°C (248 ~ 266°F) (depending on the model), the system shuts down the compressor.
- If the inverter current exceeds 12.0 ~ 20.0 A (depending on the model), the system shuts down the compressor.
The upper limit of the current decreases when the outdoor temperature exceeds a certain level.

Part 5

Remote Controller

| | |
|---------------------------------------|----|
| 1. Applicable Remote Controller | 59 |
| 2. ARC480A83 | 60 |
| 3. BRC073A6 | 62 |
| 4. BRC944B2 | 66 |

1. Applicable Remote Controller

| Model Name | Wireless R/C | Reference Page | Wired R/C | Reference Page |
|-------------|--------------|----------------|----------------------|----------------|
| FTXV09AVJU9 | ARC480A83 | 60 | BRC073A6 BRC944B2 | 62 66 |
| FTXV12AVJU9 | | | | |
| FTXV15AVJU9 | | | | |
| FTXV18AVJU9 | | | | |
| FTXV24AVJU9 | | | | |



Note

Refer to the operation manual of applicable model for details. You can download operation manuals from Daikin Business Portal:

Daikin Business Portal → Document Search → Item Category → Installation/Operation Manual
(URL: https://global1d.daikin.com/business_portal/login/)

2. ARC480A83

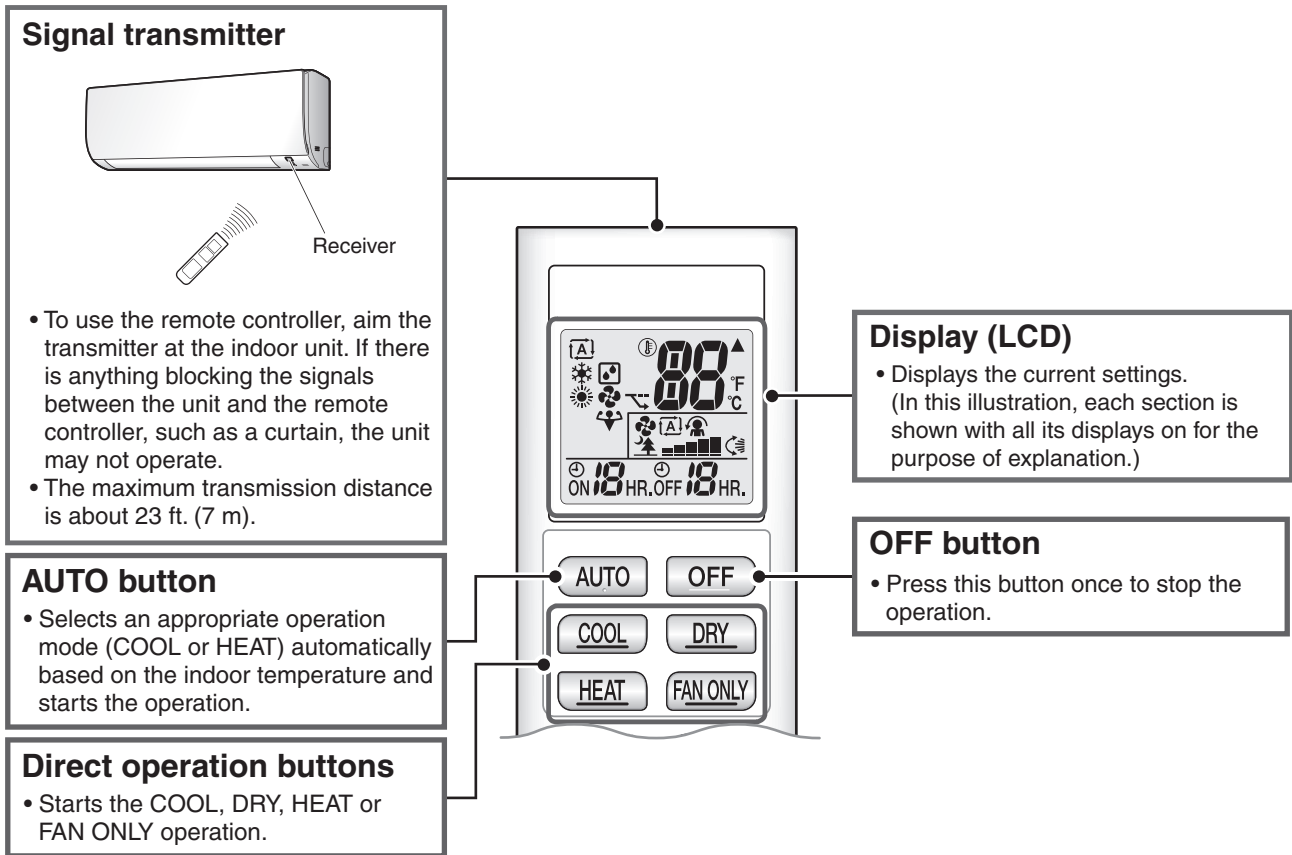

R5000453

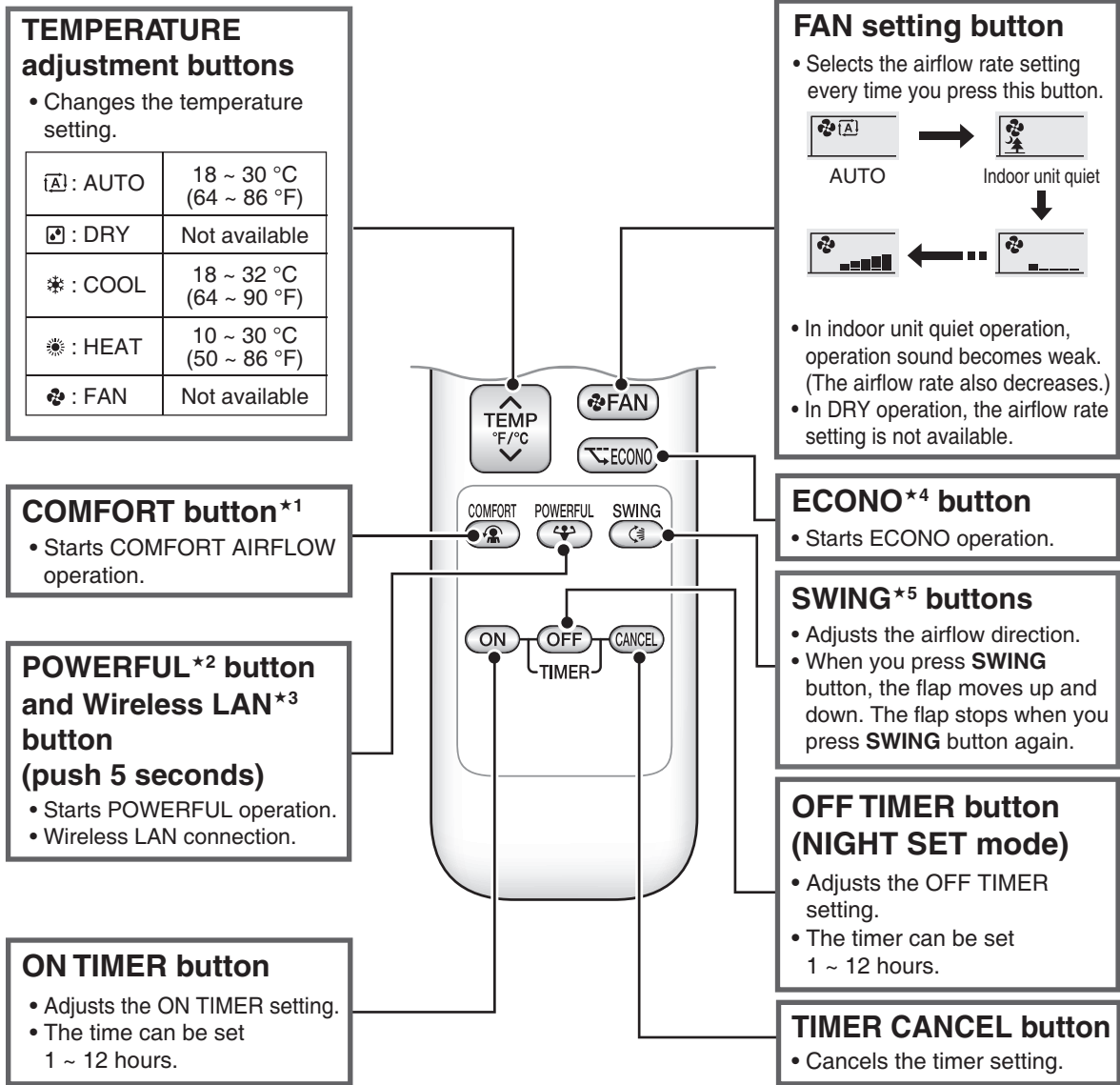

R5000461



Reference

Refer to the following pages for details.

- ★1 COMFORT AIRFLOW operation P.30
- ★2 POWERFUL operation P.36
- ★3 Wireless LAN connection P.38
- ★4 ECONO operation P.35
- ★5 Auto-swing P.29

3. BRC073A6

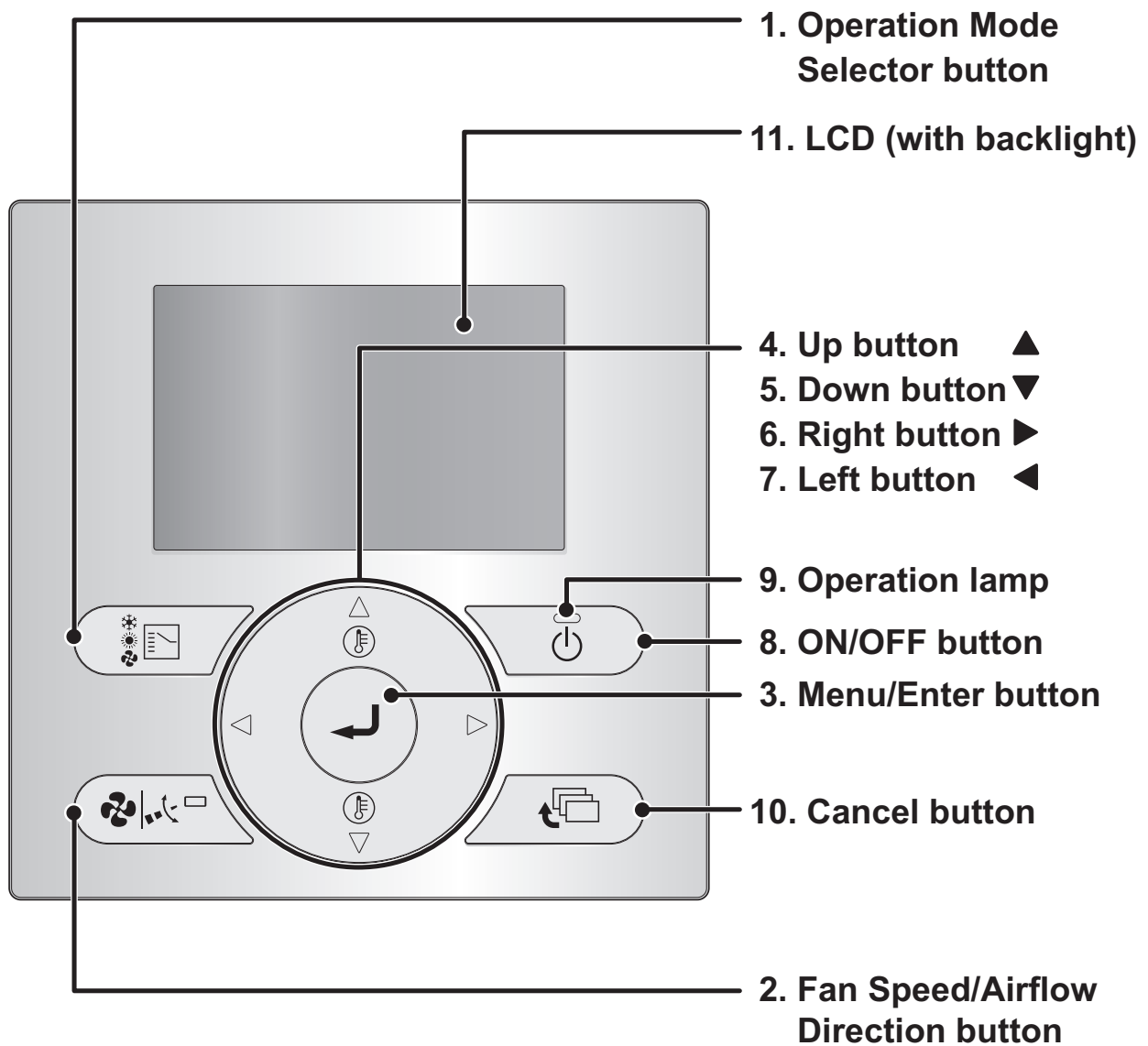

1. Operation Mode Selector button

- Press this button to select the operation mode of your preference.
- Available modes may vary with the connected model.

2. Fan Speed/Airflow Direction button

- Used to change the fan speed and airflow direction.
- Available fan speeds and airflow directions may vary with the connected model.

3. Menu/Enter button

- This button is enabled by default.
- Used to display the Main Menu or enter the selected item.

4. Up button ▲

- Used to raise the set temperature.
- The next item on the upper side will be highlighted.
(Keep pressing the button to cycle through the values or items).
- Used to change the selected item.

5. Down button ▼

- Used to lower the set temperature.
- The next item on the lower side will be highlighted.
(Keep pressing the button to cycle through the values or items).
- Used to change the selected item.

6. Right button ►

- Used to highlight the next items on the right-hand side.
- The display contents are changed to the next screen.

7. Left button ◀

- Used to highlight the next items on the left-hand side.
- The display contents are changed to the previous screen.

8. ON/OFF button

- Press to start or stop the air conditioner.

9. Operation lamp (Green)

- This lamp lights up during operation.
- This lamp is not lit when the unit operation is OFF.
- This lamp blink if an error or mode conflict occurs.

10. Cancel button

- This button is enabled by default.
- Used to return to the previous screen.

11. LCD (with backlight)

- The backlight will be lit for approximately 30 seconds when one of the buttons is pressed.
- The actions linked to the buttons, except for the ON/OFF button, are not carried out when the backlight is not lit.

Liquid Crystal Display

- There are four display methods for the liquid crystal display (LCD) available. The Standard display, which is used by default, and the Detailed display. There is also the possibility to use only Icon or Icon and Text mode (see the Installation manual).
- To change the active display method, select the desired display method in the Display Method screen.
- The displayed contents on the screen may vary with the operation mode of the connected models. (E.g.: The following display will appear when the air conditioner is in heating operation).

Standard display

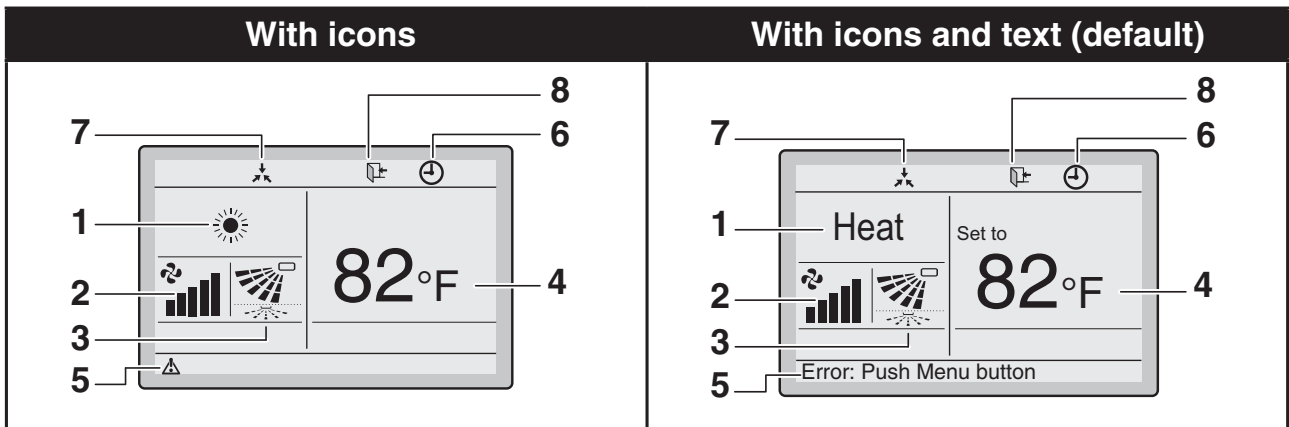





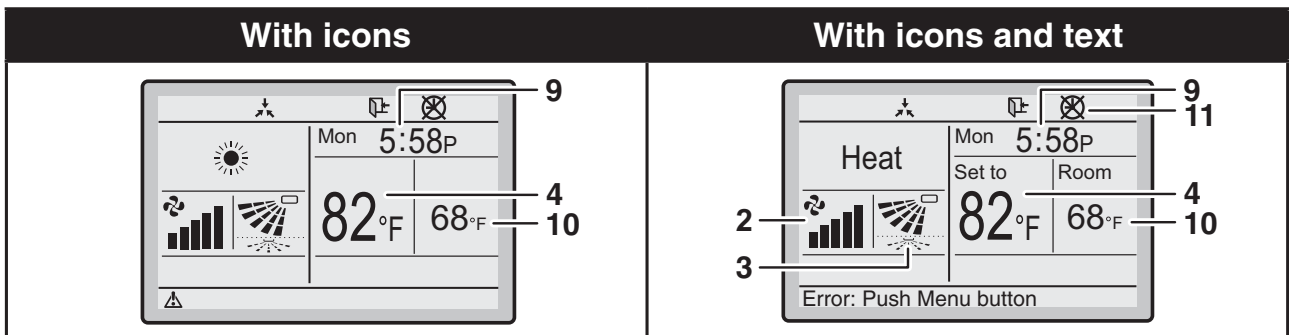

Detailed display

- The clock and Detailed selection items appear on the Detailed display in addition to the items appearing on the Standard display.



1. Operation mode

- Indicates the current operation mode.

| Operation Mode | | |
|---|---|---|
| Cool | Heat | Auto (Heat) |
|  |  |  |
| Fan | Dry | Auto (Cool) |
|  |  |  |

2. Fan Speed

- Indicates the fan speed that is set for the air conditioner.
- The fan speed will not be displayed if the air conditioner does not have the fan speed control function.

3. Airflow direction

- Displayed only when the air conditioner is in operation.
- Indicates the airflow direction that is set for the air conditioner.
- The possible directions depend on the indoor unit.

4. Set/Setback temperature display

- When the unit is turned ON, the temperature that is set for the air conditioner is displayed.
- When the unit is turned OFF and Setback is disabled, the temperature that is set for the air conditioner is displayed.
- When the unit is turned OFF and Setback is enabled, the temperature that is set for the setback function is displayed in smaller digits.

5. Error “”

- Indicates a unit error.

6. Timer enabled “”

- Indicates that the schedule timer or the OFF timer is enabled.

7. Under Centralised control “”

- Indicates that the air conditioner is under the management of central control equipment (optional accessories) and the operation of the system through the remote controller is prohibited.

8. Setback “”

- The setback icon flashes when the unit is turned on under the setback control.

9. Clock (12/24 hours real time clock)

- Indicates that the clock is set.
- If the clock is not set, “ -- : -- ” will be displayed.

10. Detailed selection

- Displayed when the detailed display mode is selected.
- No detailed items are selected by default.

11. Timer problem “”

- Indicates that the clock needs to be set again.
- The schedule timer function will not work unless the clock is set again.

4. BRC944B2

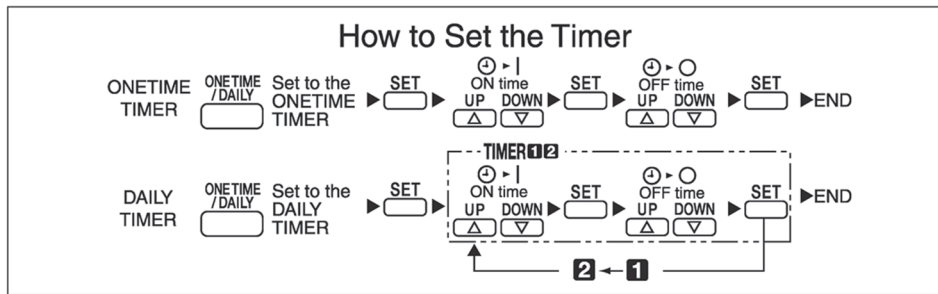
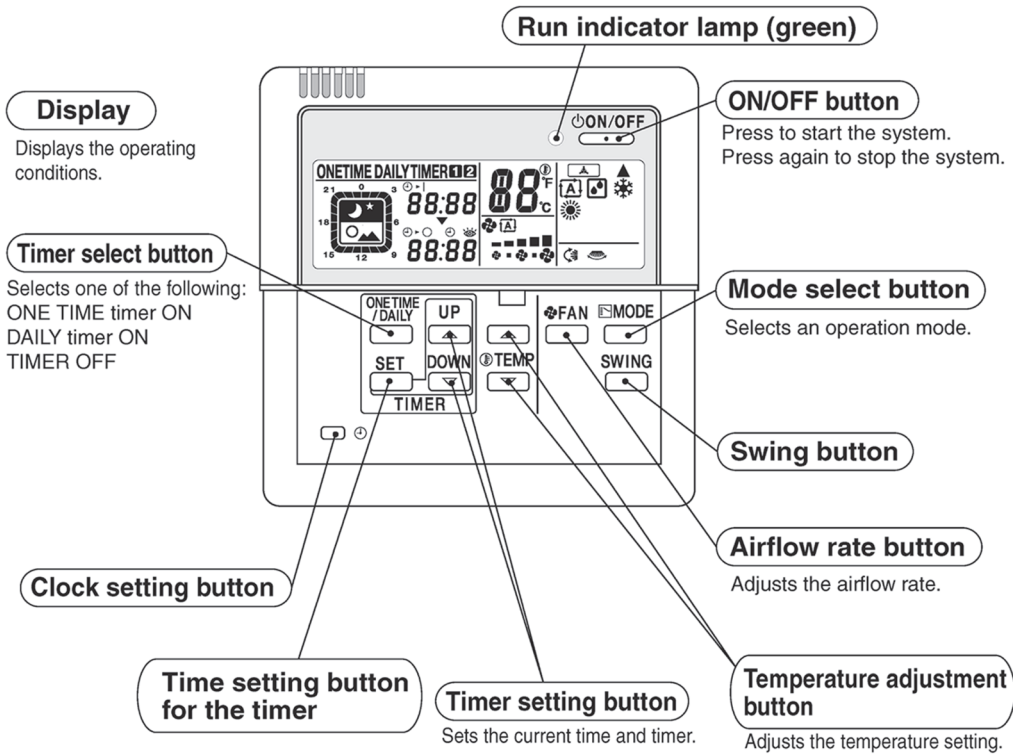

R5000214



Caution

This remote controller cannot be used together with a standard wireless remote controller. Otherwise, what appears on this remote controller's display may fail to correspond to actual operating conditions.

Part 6

Service Diagnosis

| | |
|---|-----|
| 1. General Problem Symptoms and Check Items | 69 |
| 2. Troubleshooting with LED | 70 |
| 2.1 Indoor Unit..... | 70 |
| 2.2 Outdoor Unit..... | 70 |
| 3. Service Diagnosis | 71 |
| 3.1 ARC480 Series..... | 71 |
| 3.2 BRC073A6 | 74 |
| 4. Error Codes and Description | 76 |
| 5. Troubleshooting for Indoor Unit..... | 77 |
| 5.1 Indoor Unit PCB Abnormality | 77 |
| 5.2 Freeze-up Protection Control/Heating Peak-cut Control | 78 |
| 5.3 Indoor Fan Motor (DC Motor) or Related Abnormality | 79 |
| 5.4 Indoor Heat Exchanger Thermistor or Related Abnormality..... | 81 |
| 5.5 Room Temperature Sensor Abnormality/Humidity Sensor Abnormality | 82 |
| 5.6 Low-voltage Detection or Over-voltage Detection | 83 |
| 5.7 Signal Transmission Error (Between Indoor Unit and Outdoor Unit)..... | 85 |
| 5.8 Unspecified Voltage (Between Indoor Unit and Outdoor Unit)..... | 87 |
| 6. Troubleshooting for Outdoor Unit..... | 88 |
| 6.1 Outdoor Unit PCB Abnormality..... | 88 |
| 6.2 Actuation of High Pressure Switch | 89 |
| 6.3 OL Activation (Compressor Overload) | 90 |
| 6.4 Compressor Lock | 92 |
| 6.5 DC Fan Lock | 93 |
| 6.6 Input Overcurrent Detection | 94 |
| 6.7 Electronic Expansion Valve Coil Abnormality..... | 95 |
| 6.8 Four Way Valve Abnormality..... | 96 |
| 6.9 Discharge Pipe Temperature Control..... | 98 |
| 6.10 High Pressure Control in Cooling | 99 |
| 6.11 System Shutdown due to Temperature Abnormality in the Compressor..... | 101 |
| 6.12 Compressor Sensor System Abnormality | 102 |
| 6.13 High Pressure Switch System Abnormality | 103 |
| 6.14 Position Sensor Abnormality | 104 |
| 6.15 Fan IPM temperature error..... | 107 |
| 6.16 DC Voltage/Current Sensor Abnormality..... | 108 |
| 6.17 Thermistor or Related Abnormality (Outdoor Unit)..... | 109 |
| 6.18 Electrical Box Temperature Rise..... | 111 |
| 6.19 Radiation Fin Temperature Rise | 112 |
| 6.20 Output Overcurrent Detection | 113 |
| 6.21 IGBT temperature error | 115 |
| 6.22 Signal Transmission Error on Outdoor Unit PCB | 116 |

| | |
|---|-----|
| 7. Check | 117 |
| 7.1 Thermistor Resistance Check | 117 |
| 7.2 Indoor Fan Motor Connector Check | 118 |
| 7.3 Power Supply Waveform Check..... | 118 |
| 7.4 Electronic Expansion Valve Check..... | 119 |
| 7.5 Four Way Valve Performance Check | 120 |
| 7.6 Inverter Unit Refrigerant System Check..... | 120 |
| 7.7 Inverter Analyzer Check | 121 |
| 7.8 Outdoor Fan Motor Check..... | 123 |
| 7.9 Installation Condition Check..... | 123 |
| 7.10 Discharge Pressure Check..... | 124 |
| 7.11 Outdoor Fan System Check | 124 |
| 7.12 Main Circuit Short Check..... | 125 |
| 7.13 Power Module Check | 127 |

1. General Problem Symptoms and Check Items

| Symptom | Check Item | Measures | Reference Page |
|--|--|--|----------------|
| The unit does not operate. | Check the power supply. | Check if the rated voltage is supplied. | — |
| | Check the type of the indoor unit. | Check if the indoor unit type is compatible with the outdoor unit. | — |
| | Check the outdoor temperature. | Heating/cooling operations are not available when the outdoor temperature is out of the operation limit. Check the reference page for the operation limit. | 154 |
| | Diagnose with remote controller indication. | — | 76 |
| | Check the remote controller addresses. | Check if address settings for the remote controller and indoor unit are correct. | 69 |
| Operation sometimes stops. | Check the power supply. | A power failure of 2 to 10 cycles stops air conditioner operation. (Operation lamp OFF) | — |
| | Check the outdoor temperature. | Heating/cooling operations are not available when the outdoor temperature is out of the operation limit. Check the reference page for the operation limit. | 154 |
| | Diagnose with remote controller indication. | — | 76 |
| The unit operates but does not cool, or does not heat. | Check for wiring and piping errors in the connection between the indoor unit and outdoor unit. | — | — |
| | Check for thermistor detection errors. | Check if the thermistor is mounted securely. | — |
| | Check for faulty operation of the electronic expansion valve. | Set the unit to cooling operation, and check the temperature of the liquid pipe to see if the electronic expansion valve works. | — |
| | Diagnose with remote controller indication. | — | 76 |
| | Diagnose by service port pressure and operating current. | Check for refrigerant shortage. | — |
| Large operating noise and vibrations | Check the resistance between the terminals of the power module. | — | 127 |
| | Check the power module. | — | — |
| | Check the installation condition. | Check if the required spaces for installation (specified in the installation manual) are provided. | — |

2. Troubleshooting with LED

2.1 Indoor Unit

Operation Lamp

The operation lamp blinks when any of the following errors is detected.

1. When a protection device of the indoor or outdoor unit is activated, or when the thermistor malfunctions.
2. When a signal transmission error occurs between the indoor and outdoor units.

In either case, conduct the diagnostic procedure described in the following pages.

09/12 class

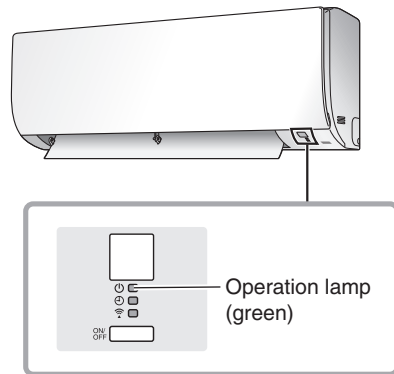

R6001149

15/18/24 class

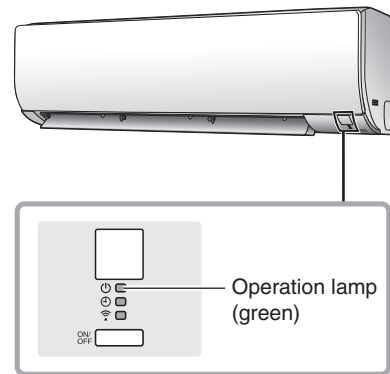

R6001150

2.2 Outdoor Unit

The outdoor unit has one green LED (LED A) on the PCB. When the microcomputer works in order, the LED A blinks. However, the LED A turns OFF while the standby electricity saving function is activated and the power supply is OFF.

Refer to page 22, 24, 25 for the location of LED A.

3. Service Diagnosis

3.1 ARC480 Series

3.1.1 Method 1

1. When **TIMER CANCEL** button is held down for 5 seconds, **00** is displayed on the temperature display screen.
2. Press **TIMER CANCEL** button repeatedly until a long beep sounds.

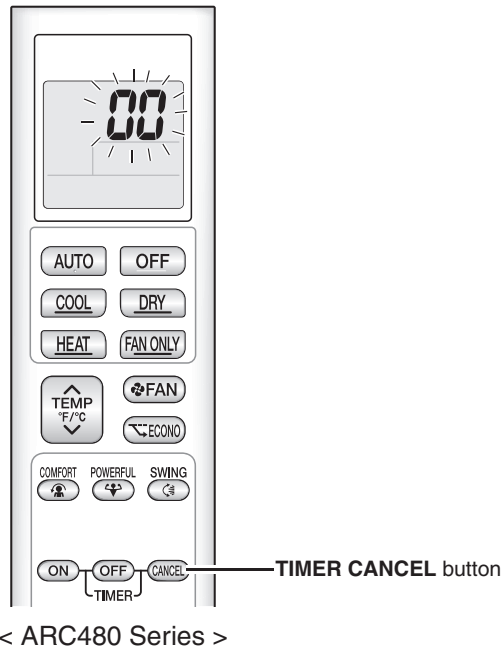

R6001152



Note(s)

1. A short beep or two consecutive beeps indicate non-corresponding codes.
2. To return to the normal mode, hold **TIMER CANCEL** button down for 5 seconds. When the remote controller is left untouched for 60 seconds, it also returns to the normal mode.
3. Not all the error codes are displayed. When you cannot find the error code, try method 2. Refer to page 72.

- The code indication changes in the sequence shown below.

ARC480A83

| No. | Code | No. | Code | No. | Code |
|-----|-----------|-----|-----------|-----|-----------|
| 1 | 00 | 16 | A3 | 31 | UF |
| 2 | A5 | 17 | H8 | 32 | UH |
| 3 | E7 | 18 | H9 | 33 | P4 |
| 4 | F3 | 19 | C9 | 34 | H7 |
| 5 | F6 | 20 | CC | 35 | U2 |
| 6 | L3 | 21 | C4 | 36 | EA |
| 7 | L4 | 22 | C5 | 37 | AH |
| 8 | L5 | 23 | J3 | 38 | E9 |
| 9 | U4 | 24 | J6 | 39 | FA |
| 10 | E6 | 25 | J8 | 40 | E8 |
| 11 | H6 | 26 | E5 | 41 | CH |
| 12 | H0 | 27 | A1 | 42 | J9 |
| 13 | A6 | 28 | E1 | 43 | E3 |
| 14 | U0 | 29 | UA | 44 | H3 |
| 15 | C7 | 30 | U3 | 45 | F8 |

3.1.2 Method 2

1. Press the center of **TEMP** button and **OFF** button at the same time.

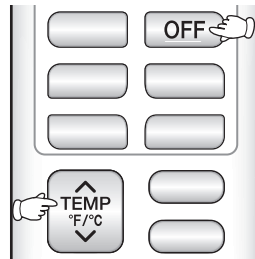

SC is displayed on the LCD.

R6001161

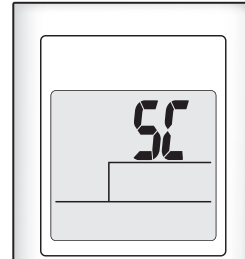

2. Select **SC** (service check) with **TEMP ▲** or **TEMP ▼** button.
3. Press **FAN** button to enter the service check mode.

R6001158

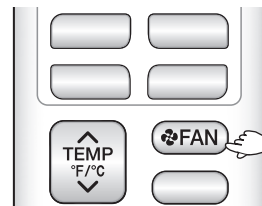

00 is displayed and the left-side number blinks.

R6001162

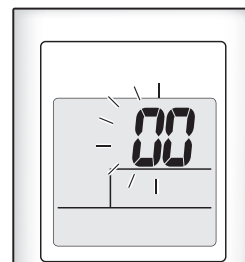

4. Press **TEMP ▲** or **TEMP ▼** button and change the number until you hear the two consecutive beeps or the long beep.

R6001159

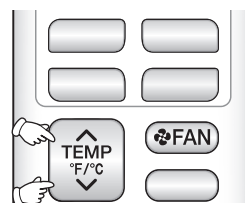

5. Diagnose by the sound.

R6001163

- Beep: The left-side number does not correspond with the error code.
- Two consecutive beeps: The left-side number corresponds with the error code but the right-side number does not.
- Long beep: Both the left-side and right-side numbers correspond with the error code. The numbers indicated when you hear the long beep are the error code. Refer to Error codes and description on page 76.

6. Press **FAN** button.

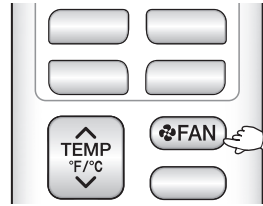

The right-side number blinks.

R6001162

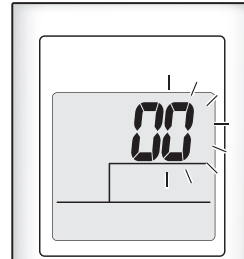

7. Press **TEMP ▲** or **TEMP ▼** button and change the number until you hear the long beep.

R6001160

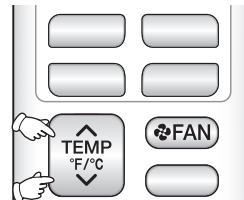

R6001163

8. Diagnose by the sound.

- Beep: The left-side number does not correspond with the error code.
- Two consecutive beeps: The left-side number corresponds with the error code but the right-side number does not.
- Long beep: Both the left-side and right-side numbers correspond with the error code.

9. Determine the error code.

The numbers indicated when you hear the long beep are the error code.
Refer to Error codes and description on page 76.

10. Press **FAN** button for 5 seconds to exit from the service check mode.

When the remote controller is left untouched for 60 seconds, it returns to the normal mode also.

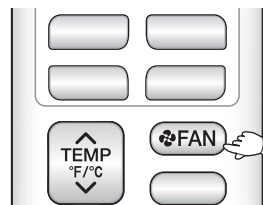

R6001162

3.2 BRC073A6

Relations Between Modes

On power-up, the message “Checking the connection. Please standby.” will be displayed on the remote controller screen temporarily and then the basic screen will be displayed. To access a mode from the basic screen, refer to the figure below.

When any of the operation buttons are pressed, the backlight will come on and remain lit for about 30 seconds. Be sure to press a button while the backlight is on.

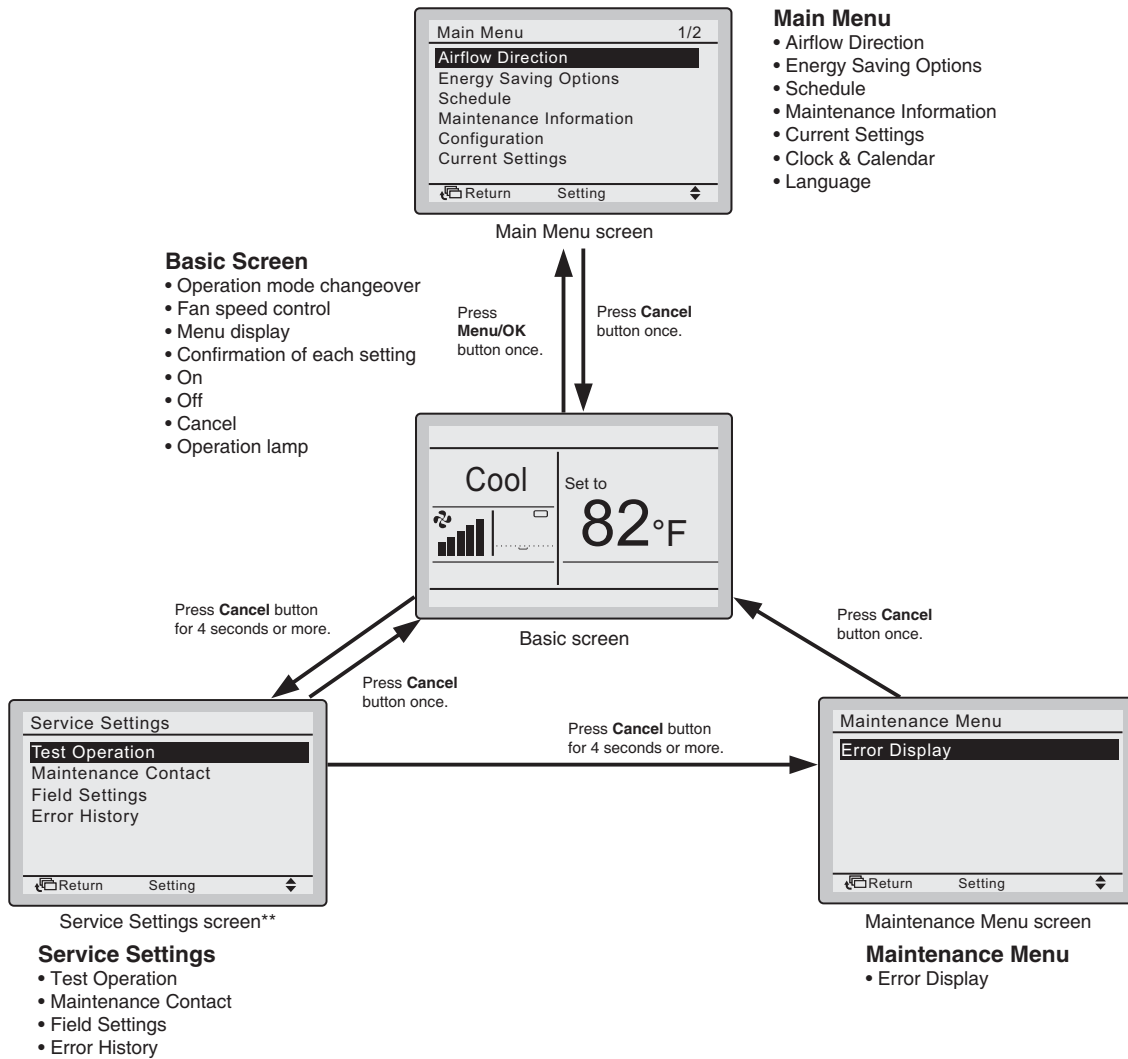

★ The items shown on the remote controller are different depending on the connected indoor unit.
 ** Not displayed in multi-split system.

Service Diagnosis

The following message is displayed on the screen when an error occurs during operation. Check the error code and take the corrective action specified for the particular model.

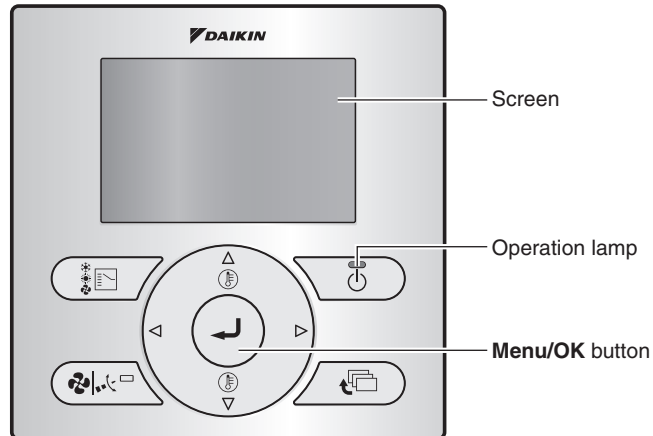

Operation Method

1

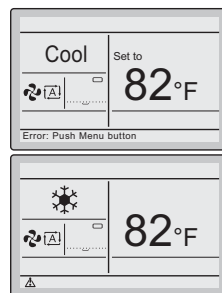

- If an error occurs, the error message or error icon and the operation lamp will blink.
- To display the error code and contact information, the Menu/Enter button needs to be enabled.
- Press the Menu/Enter button.

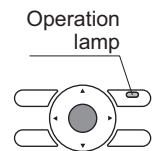

2

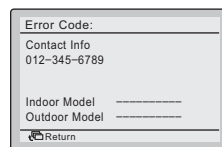

- The error code blinks and the contact address will appear.
- Notify your Daikin dealer of the Error code and Model name.

4. Error Codes and Description

| | Error Codes | Description | Reference Page |
|--------------|---|--|----------------|
| System | 00 | Normal | — |
| | U0 | Refrigerant shortage | — |
| | U2 | Low-voltage detection or over-voltage detection | 83 |
| | U4 | Signal transmission error (between indoor unit and outdoor unit) | 85 |
| | UA | Unspecified voltage (between indoor unit and outdoor unit) | 87 |
| Indoor Unit | A1 | Indoor unit PCB abnormality | 77 |
| | A5 | Freeze-up protection control/heating peak-cut control | 78 |
| | A6 | Indoor fan motor (DC motor) or related abnormality | 79 |
| | C4 | Indoor heat exchanger thermistor or related abnormality | 81 |
| | C9 | Room temperature thermistor or related abnormality | 82 |
| | CC | Humidity sensor abnormality | 82 |
| Outdoor Unit | E1 | Outdoor unit PCB abnormality | 88 |
| | E3 | Actuation of high pressure switch | 89 |
| | E5 | OL activation (compressor overload) | 90 |
| | E6 | Compressor lock | 92 |
| | E7 | DC fan lock | 93 |
| | E8 | Input overcurrent detection | 94 |
| | E9 | Electronic expansion valve abnormality | 95 |
| | EA | Four way valve abnormality | 96 |
| | F3 | Discharge pipe temperature control | 98 |
| | F6 | High pressure control in cooling | 99 |
| | F8 | System shutdown due to temperature abnormality in the compressor | 101 |
| | H0 | Compressor system sensor abnormality | 102 |
| | H3 | High pressure switch system abnormality | 103 |
| | H6 | Position sensor abnormality | 104 |
| | H7 | Fan IPM temperature error | 107 |
| | H8 | DC Voltage/Current Sensor Abnormality | 108 |
| | H9 | Outdoor temperature thermistor or related abnormality | 109 |
| | J3 | Discharge pipe thermistor or related abnormality | 109 |
| | J6 | Outdoor heat exchanger thermistor or related abnormality | 109 |
| | L3 | Electrical box temperature rise | 111 |
| | L4 | Radiation fin temperature rise | 112 |
| | L5 | Output overcurrent detection | 113 |
| | LA | IGBT temperature error | 115 |
| | P4 | Radiation fin thermistor or related abnormality | 109 |
| U7 | Signal transmission error on outdoor unit PCB | 116 | |

5. Troubleshooting for Indoor Unit

5.1 Indoor Unit PCB Abnormality

| | |
|----------------------------------|---|
| Error Code | A1 |
| Method of Error Detection | The system checks if the circuit works properly within the microcomputer of the indoor unit. |
| Error Decision Conditions | The system cannot set the internal settings. |
| Supposed Causes | <ul style="list-style-type: none"> ■ Wrong models interconnected ■ Defective indoor unit PCB ■ Disconnection of connector ■ Reduction of power supply voltage |

Troubleshooting

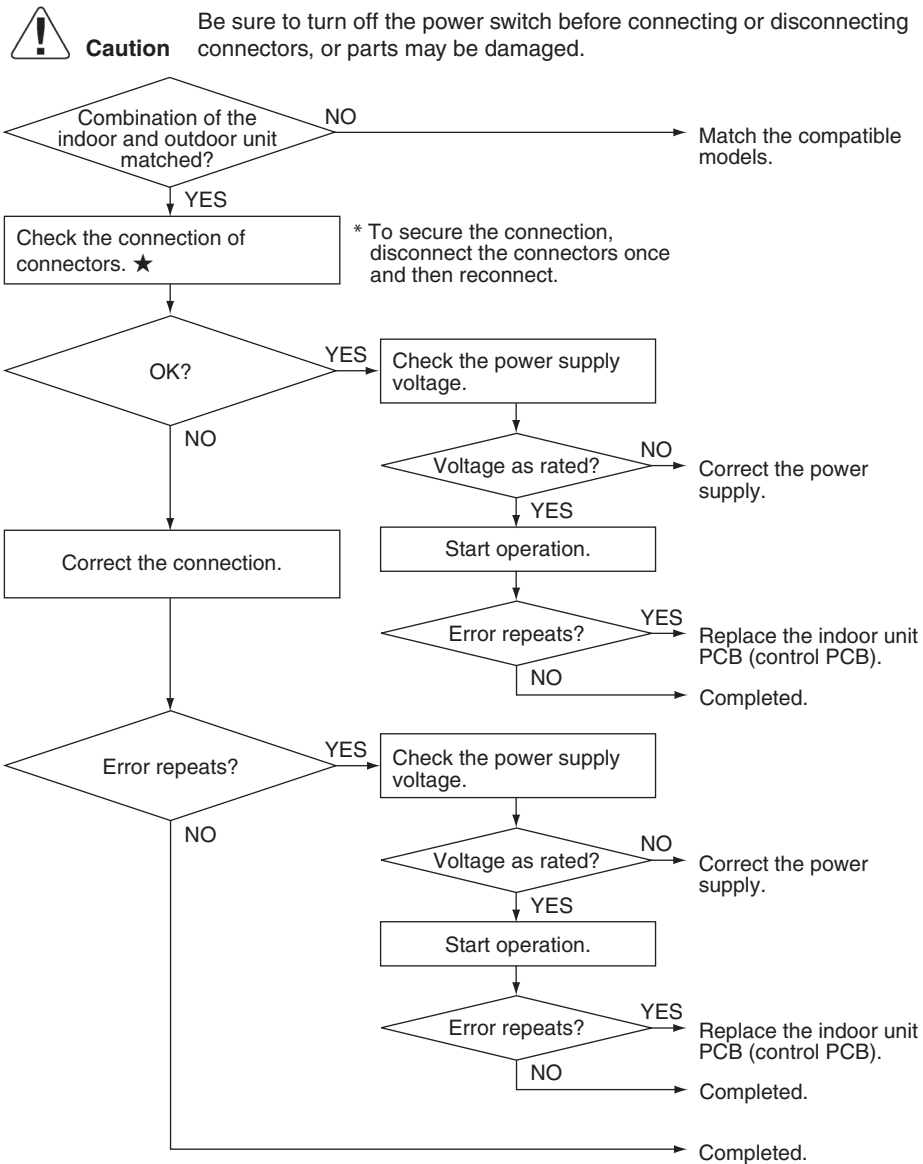

(R23407)



Note

★ Wire Harness (Connector): Terminal strip ~ Control PCB (S1)

5.2 Freeze-up Protection Control/Heating Peak-cut Control

| | |
|----------------------------------|---|
| Error Code | A5 |
| Method of Error Detection | <ul style="list-style-type: none"> ■ Freeze-up protection control During cooling operation, the freeze-up protection control (operation halt) is activated according to the temperature detected by the indoor heat exchanger thermistor. ■ Heating peak-cut control During heating operation, the temperature detected by the indoor heat exchanger thermistor is used for the heating peak-cut control (operation halt, outdoor fan stop, etc.) |
| Error Decision Conditions | <ul style="list-style-type: none"> ■ Freeze-up protection control During cooling operation, the indoor heat exchanger temperature is below 0°C (32°F). ■ Heating peak-cut control During heating operation, the indoor heat exchanger temperature is above 59 ~ 60°C (138.2 ~ 140°F). |
| Supposed Causes | <ul style="list-style-type: none"> ■ Short-circuited air ■ Clogged air filter of the indoor unit ■ Dust accumulation on the indoor heat exchanger ■ Defective indoor heat exchanger thermistor ■ Defective indoor unit PCB |

Troubleshooting

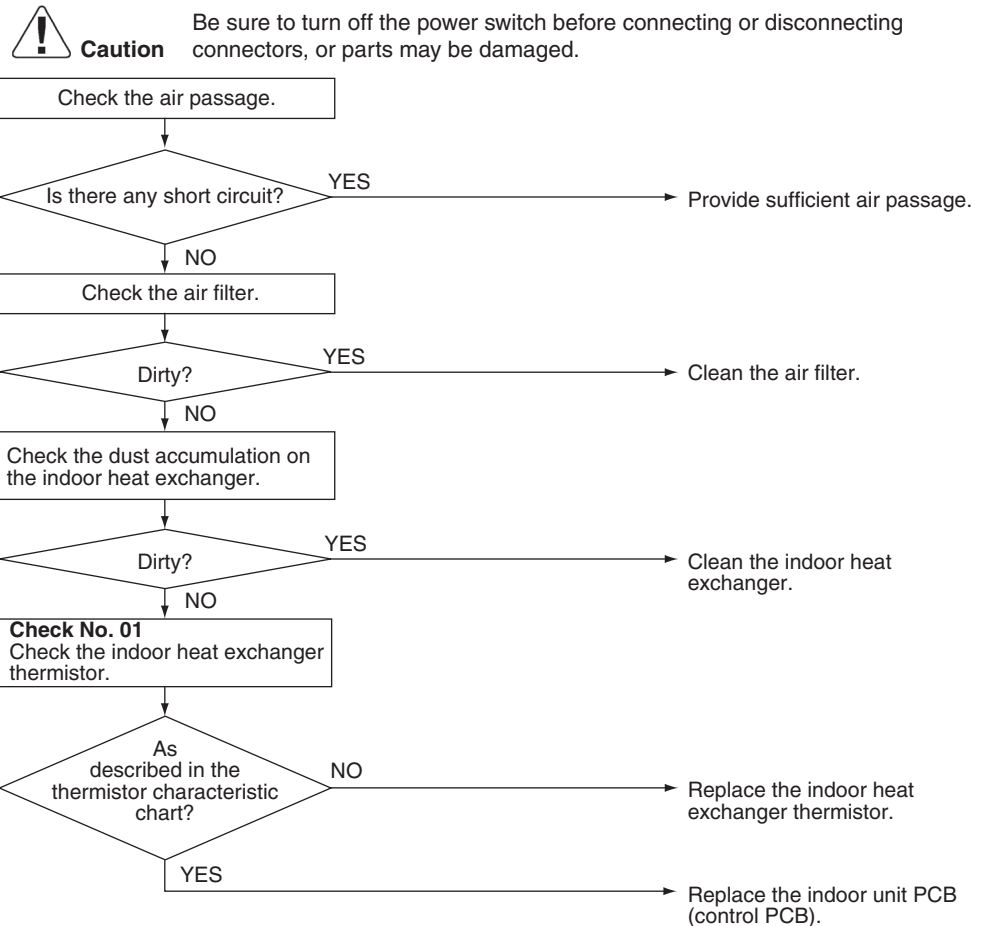

(R21064)



Reference

Check No.01 Refer to P.117

5.3 Indoor Fan Motor (DC Motor) or Related Abnormality

| | |
|----------------------------------|---|
| Error Code | A6 |
| Method of Error Detection | The rotation speed detected by the Hall IC during fan motor operation determines abnormal fan motor operation. |
| Error Decision Conditions | The detected rotation speed does not reach the demanded rotation speed of the target tap, and is less than 50% of the maximum fan motor rotation speed. |
| Supposed Causes | <ul style="list-style-type: none"> ■ Remarkable decrease in power supply voltage ■ Layer short inside the fan motor winding ■ Breaking of wire inside the fan motor ■ Breaking of the fan motor lead wires ■ Defective capacitor of the fan motor ■ Defective indoor unit PCB |

Troubleshooting

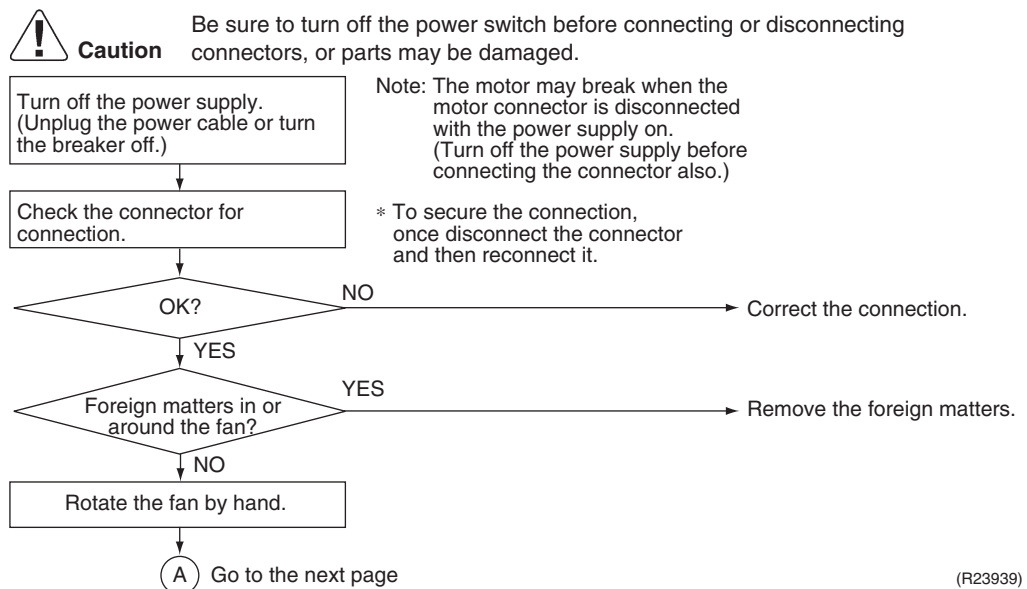

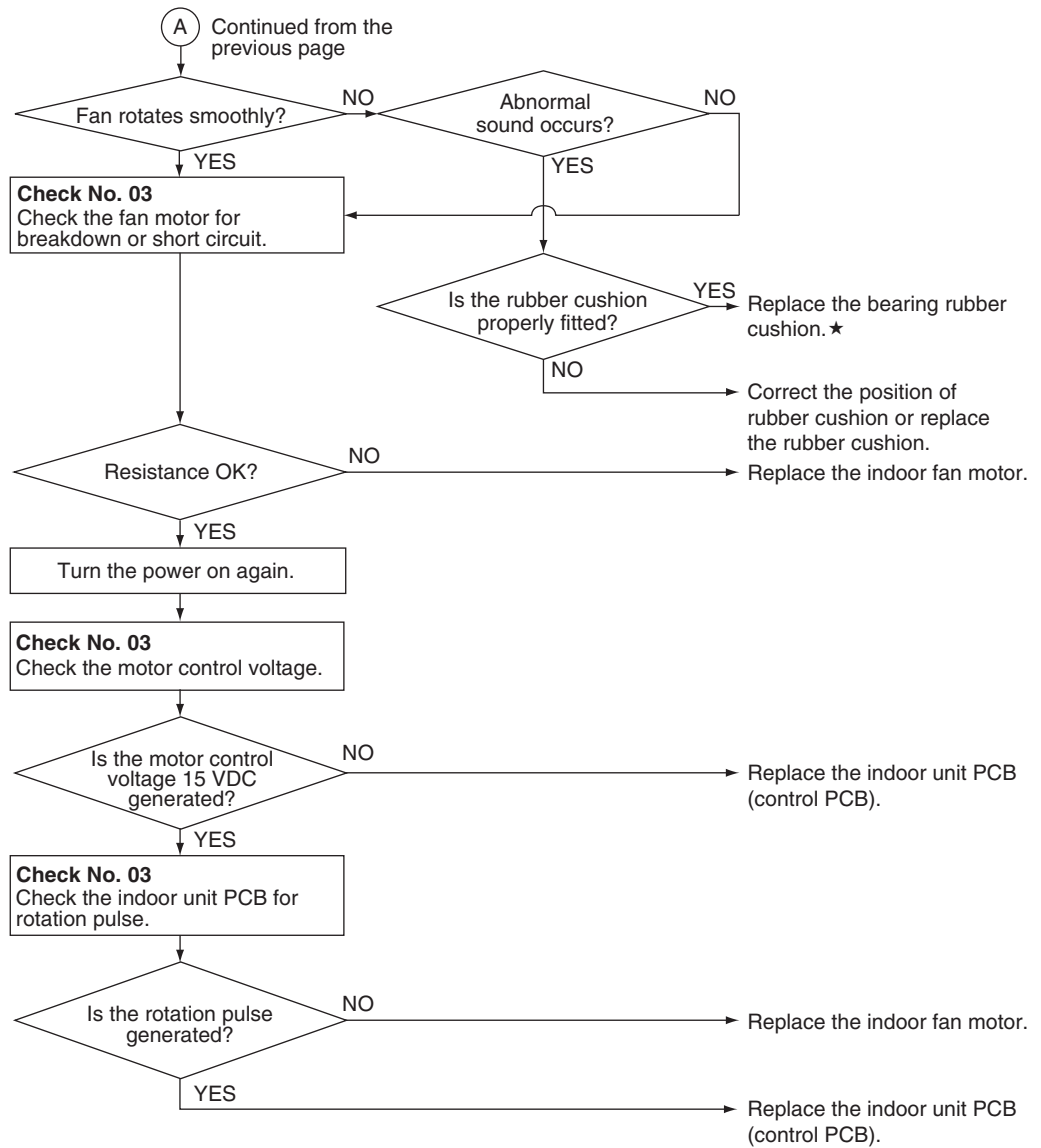

(R24945)

★Rubber cushion
09/12 class

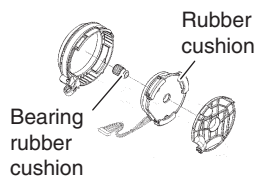

15/18/24 class

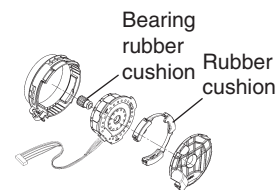

R6000581

R6000306



Reference Check No.03 Refer to P.118

5.4 Indoor Heat Exchanger Thermistor or Related Abnormality

| | |
|----------------------------------|--|
| Error Code | C4 |
| Method of Error Detection | The temperatures detected by the thermistors determine thermistor errors. |
| Error Decision Conditions | The voltage between the both ends of the thermistor is either 4.96 V or more, or 0.04 V or less with the power on. |
| Supposed Causes | <ul style="list-style-type: none"> ■ Disconnection of connector ■ Defective thermistor(s) ■ Defective indoor unit PCB |

Troubleshooting

Caution

Be sure to turn off the power switch before connecting or disconnecting connectors, or parts may be damaged.

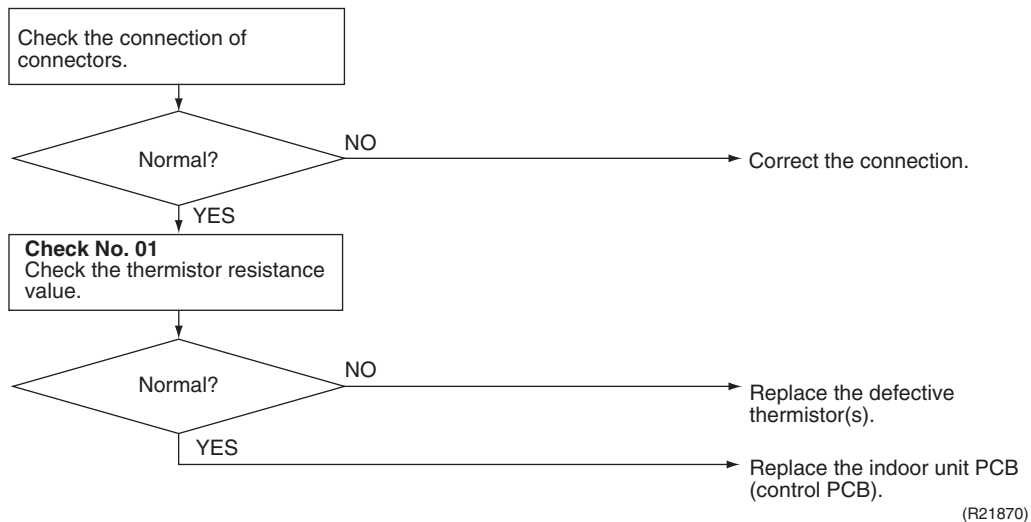

(R21870)

C4 : Indoor heat exchanger thermistor



Reference

Check No.01 Refer to P.117

5.5 Room Temperature Sensor Abnormality/Humidity Sensor Abnormality

| | |
|----------------------------------|--|
| Error Code | C9, CC |
| Method of Error Detection | Sensor abnormality is detected by input value. |
| Error Decision Conditions | The input from the humidity sensor is 4.96 V and more or 0.04 V and less. |
| Supposed Causes | <ul style="list-style-type: none"> ■ Disconnection of connector ■ Defective humidity sensor ■ Defective indoor unit PCB |

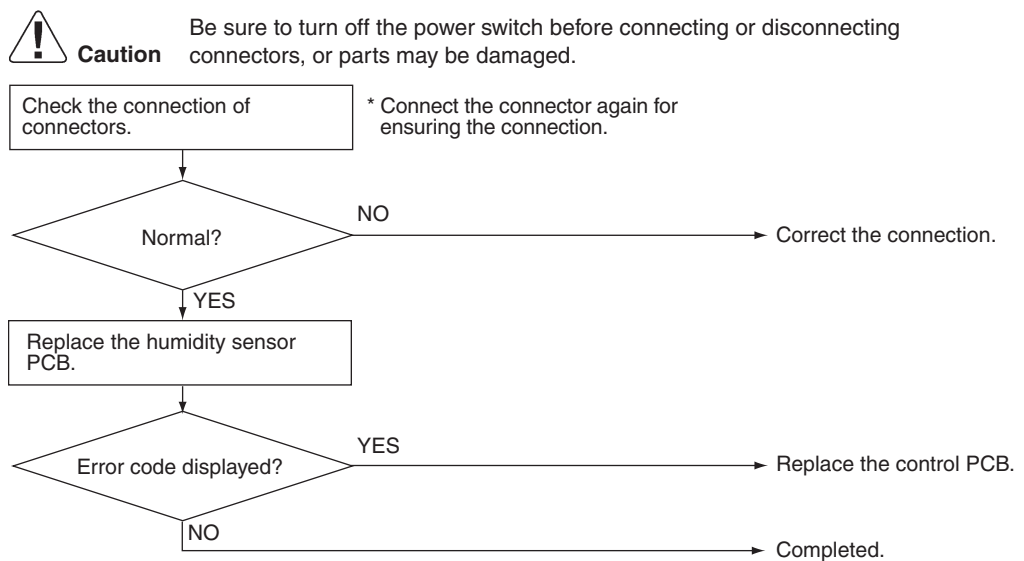
Troubleshooting



C9 : Room temperature sensor
CC : Humidity sensor

R6000515

5.6 Low-voltage Detection or Over-voltage Detection

| | |
|----------------------------------|---|
| Error Code | U2 |
| Method of Error Detection | <p>Low-voltage detection: An abnormal voltage drop is detected by the DC voltage detection circuit.</p> <p>Over-voltage detection: An abnormal voltage rise is detected by the over-voltage detection circuit.</p> |
| Error Decision Conditions | <p>Low-voltage detection:</p> <ul style="list-style-type: none"> ■ The voltage detected by the DC voltage detection circuit is below 170 V (depending on the model). ■ The compressor stops if the error occurs, and restarts automatically after 3-minute standby. <p>Over-voltage detection:</p> <ul style="list-style-type: none"> ■ An over-voltage signal is fed from the over-voltage detection circuit to the microcomputer (over 458 ~ 478 V, depending on the model). ■ The compressor stops if the error occurs, and restarts automatically after 3-minute standby. |
| Supposed Causes | <ul style="list-style-type: none"> ■ Power supply voltage out of specification ■ Defective DC voltage detection circuit ■ Defective over-voltage detection circuit ■ Defective PAM control part ■ Disconnection of compressor harness ■ Short circuit inside the fan motor winding ■ Noise ■ Momentary drop of voltage ■ Momentary power failure ■ Defective outdoor unit PCB |

Troubleshooting

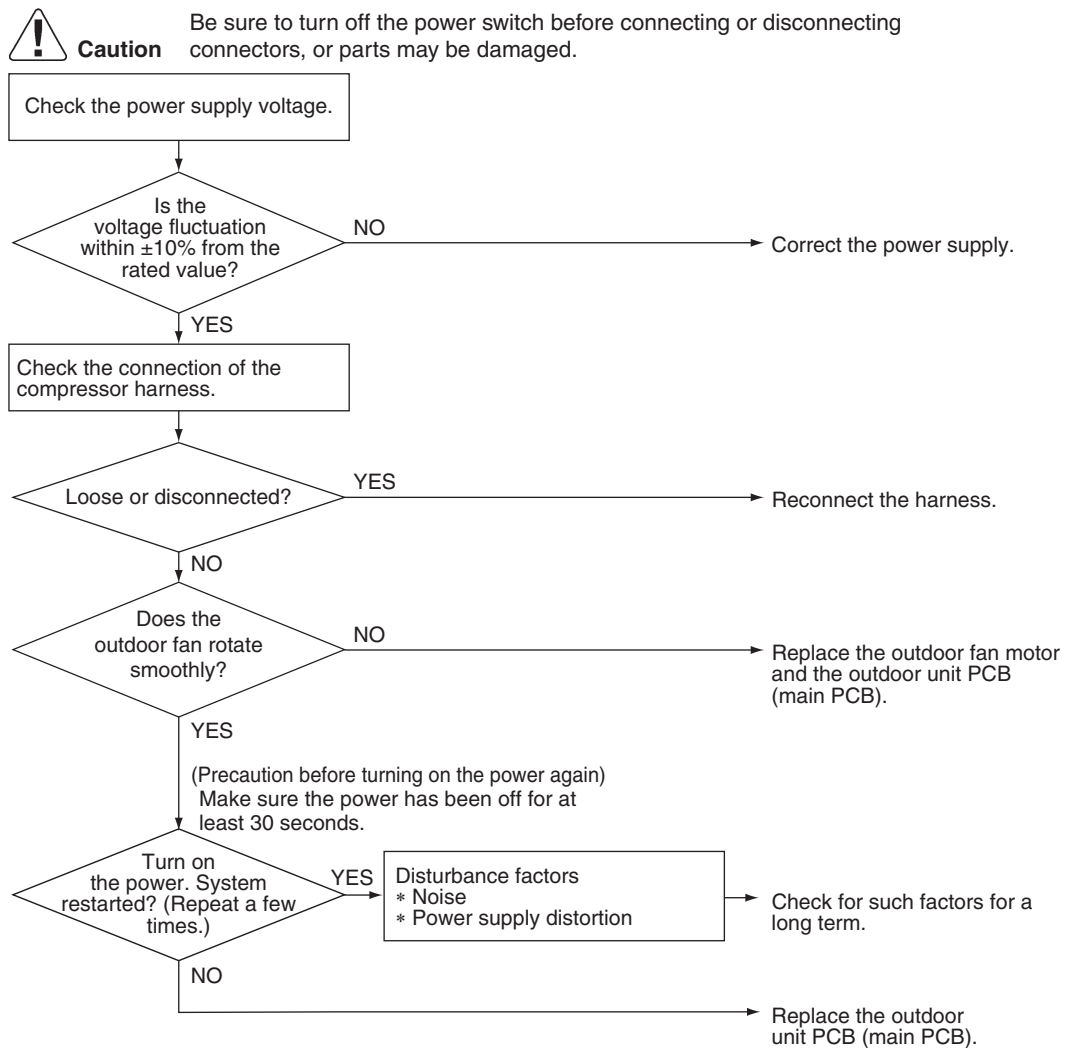

(R22445)

5.7 Signal Transmission Error (Between Indoor Unit and Outdoor Unit)

| | |
|----------------------------------|---|
| Error Code | U4 |
| Method of Error Detection | The signal transmission data received from the outdoor unit is checked whether it is normal. |
| Error Decision Conditions | The data sent from the outdoor unit cannot be received normally, or the content of the data is abnormal. |
| Supposed Causes | <ul style="list-style-type: none">■ Power supply voltage not as specified■ Reduction of power supply voltage■ Wiring error■ Breaking of the connection wires between the indoor and outdoor units (wire No. 3)■ Defective outdoor unit PCB■ Short circuit inside the fan motor winding■ Defective indoor unit PCB■ Disturbed power supply waveform |

Troubleshooting



Caution Be sure to turn off the power switch before connecting or disconnecting connectors, or parts may be damaged.

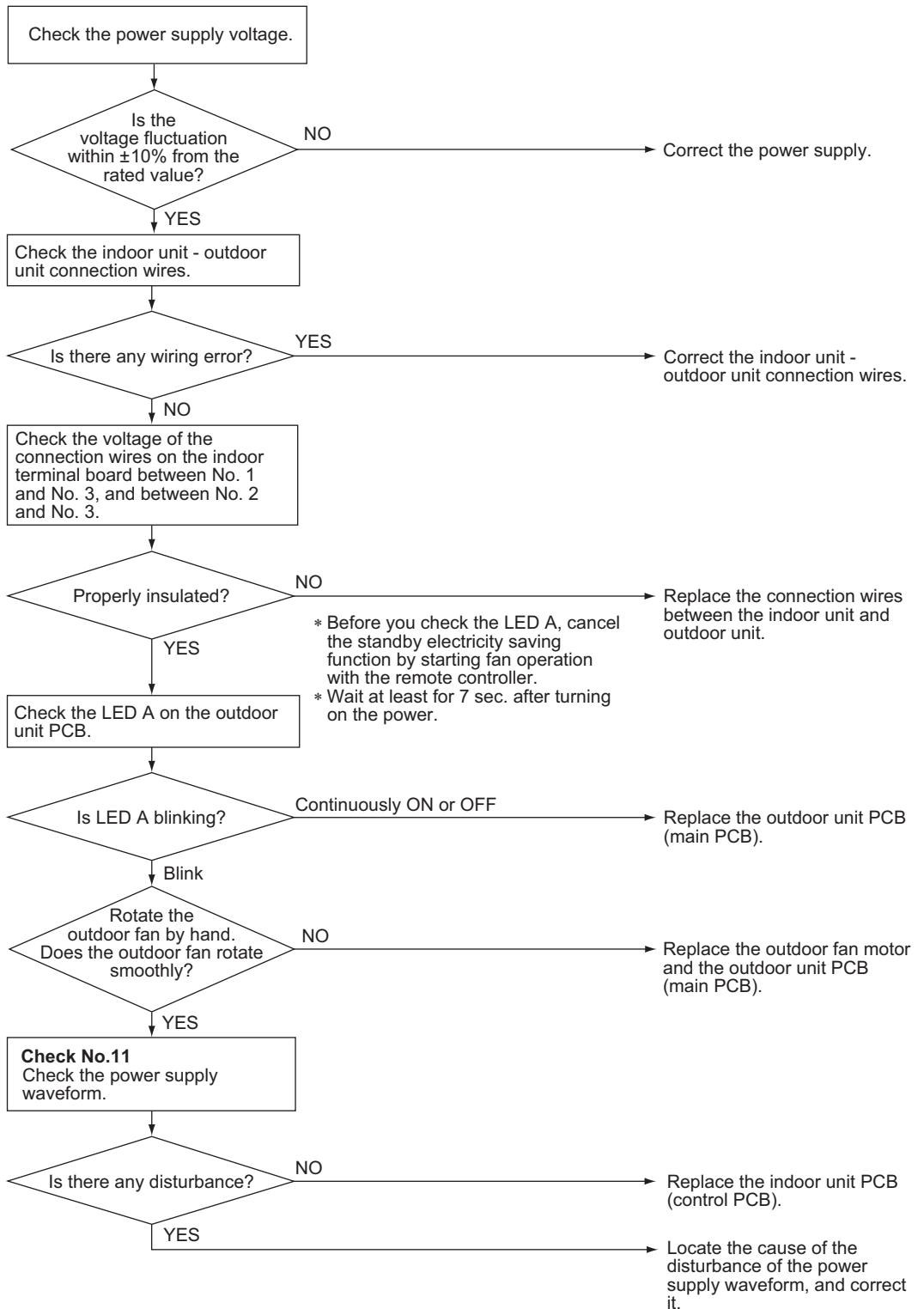

(R21189)



Reference

Check No.11 Refer to P.118

5.8 Unspecified Voltage (Between Indoor Unit and Outdoor Unit)

Error Code

UA

Method of Error Detection

The supply power is detected for its requirements (pair type is different from multi type) by the indoor/outdoor transmission signal.

Error Decision Conditions

The pair type and multi type are interconnected.

Supposed Causes

- Wrong models interconnected
- Wrong wiring of connecting wires
- Wrong indoor unit PCB or outdoor unit PCB mounted
- Defective indoor unit PCB
- Defective outdoor unit PCB

Troubleshooting



Caution

Be sure to turn off the power switch before connecting or disconnecting connectors, or parts may be damaged.

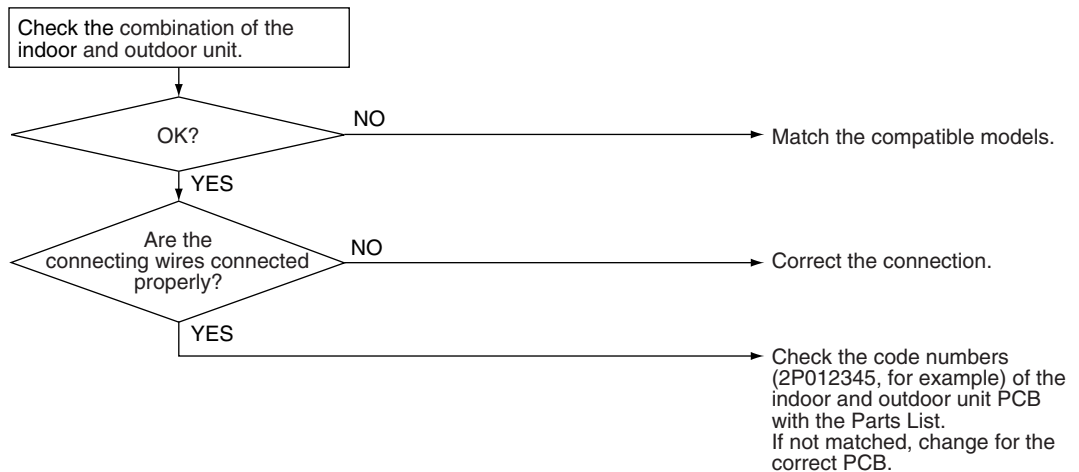

6. Troubleshooting for Outdoor Unit

6.1 Outdoor Unit PCB Abnormality

| | |
|----------------------------------|---|
| Error Code | E1 |
| Method of Error Detection | <ul style="list-style-type: none"> ■ The system checks if the microprocessor is working in order. ■ The system checks if the zero-cross signal comes in properly. |
| Error Decision Conditions | <ul style="list-style-type: none"> ■ The microprocessor program runs out of control. ■ The zero-cross signal is not detected. |
| Supposed Causes | <ul style="list-style-type: none"> ■ Defective outdoor unit PCB ■ Defective electronic expansion valve driver ■ Defective IGBT temperature detection thermistor circuit (15-24 class only) ■ Defective Fan IPM temperature detection thermistor circuit (15-24 class only) ■ Noise ■ Momentary drop of voltage ■ Momentary power failure |

Troubleshooting

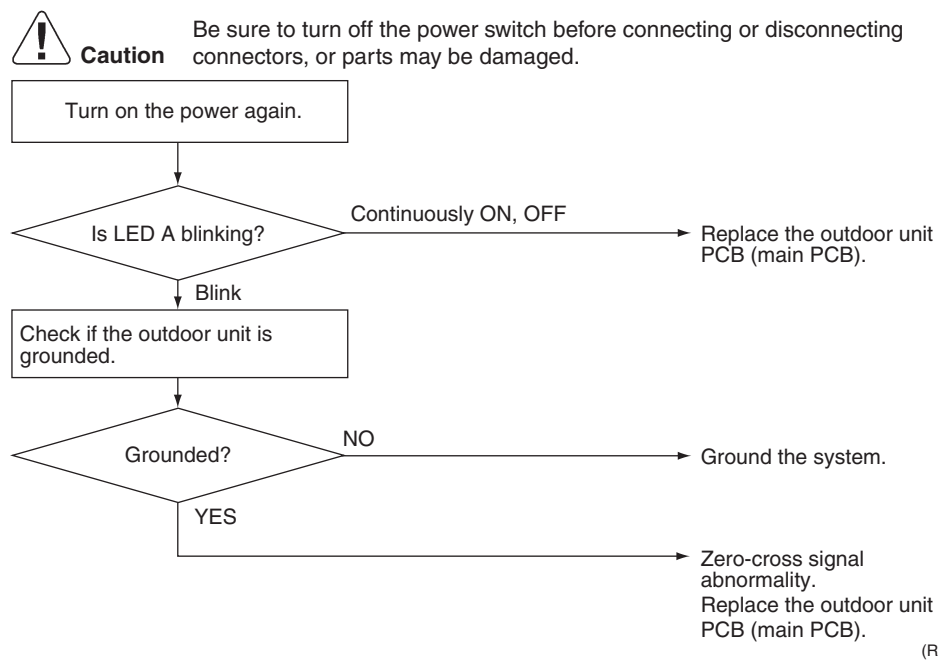

6.2 Actuation of High Pressure Switch

| | |
|----------------------------------|--|
| Error Code | E3 |
| Method of Error Detection | Abnormality is detected when the contact of the high pressure switch opens. |
| Error Decision Conditions | <ul style="list-style-type: none"> ■ High pressure switch (S1PH) activating pressure: 4.15 MPa (602 psi) ■ High pressure switch (S1PH) recovery pressure: 3.2 MPa (464 psi) |
| Supposed Causes | <ul style="list-style-type: none"> ■ Actuation of high pressure switch (S1PH) ■ Closed stop valve ■ Disconnection of connector X40A or X820A ■ Disconnection of 2 terminals of high pressure switch (S1PH) ■ Defective outdoor unit PCB ■ Broken S1PH harness ■ Defective high pressure switch (S1PH) |

Troubleshooting

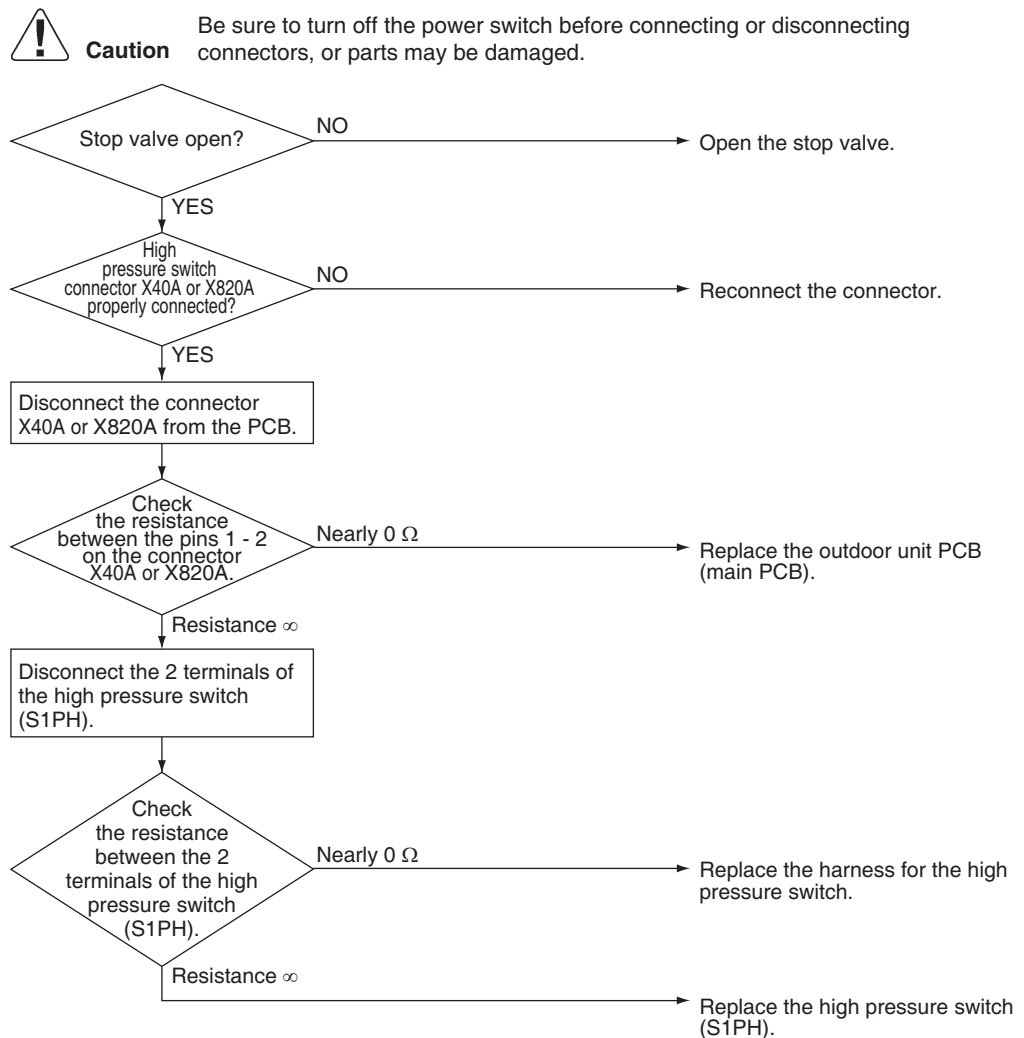

R6001215

6.3 OL Activation (Compressor Overload)

| | |
|----------------------------------|--|
| Error Code | E5 |
| Method of Error Detection | A compressor overload is detected through compressor OL. |
| Error Decision Conditions | <ul style="list-style-type: none"> ■ If the error repeats, the system is shut down. ■ Reset condition: Continuous run for about 60 minutes without any other error |
| Supposed Causes | <ul style="list-style-type: none"> ■ Disconnection of discharge pipe thermistor ■ Defective discharge pipe thermistor ■ Disconnection of connector X40A or X820A ■ Disconnection of 2 terminals of OL (Q1M) ■ Defective OL (Q1M) ■ Broken OL harness ■ Defective electronic expansion valve or coil ■ Defective four way valve or coil ■ Defective outdoor unit PCB ■ Refrigerant shortage ■ Water mixed in refrigerant ■ Defective stop valve |

Troubleshooting



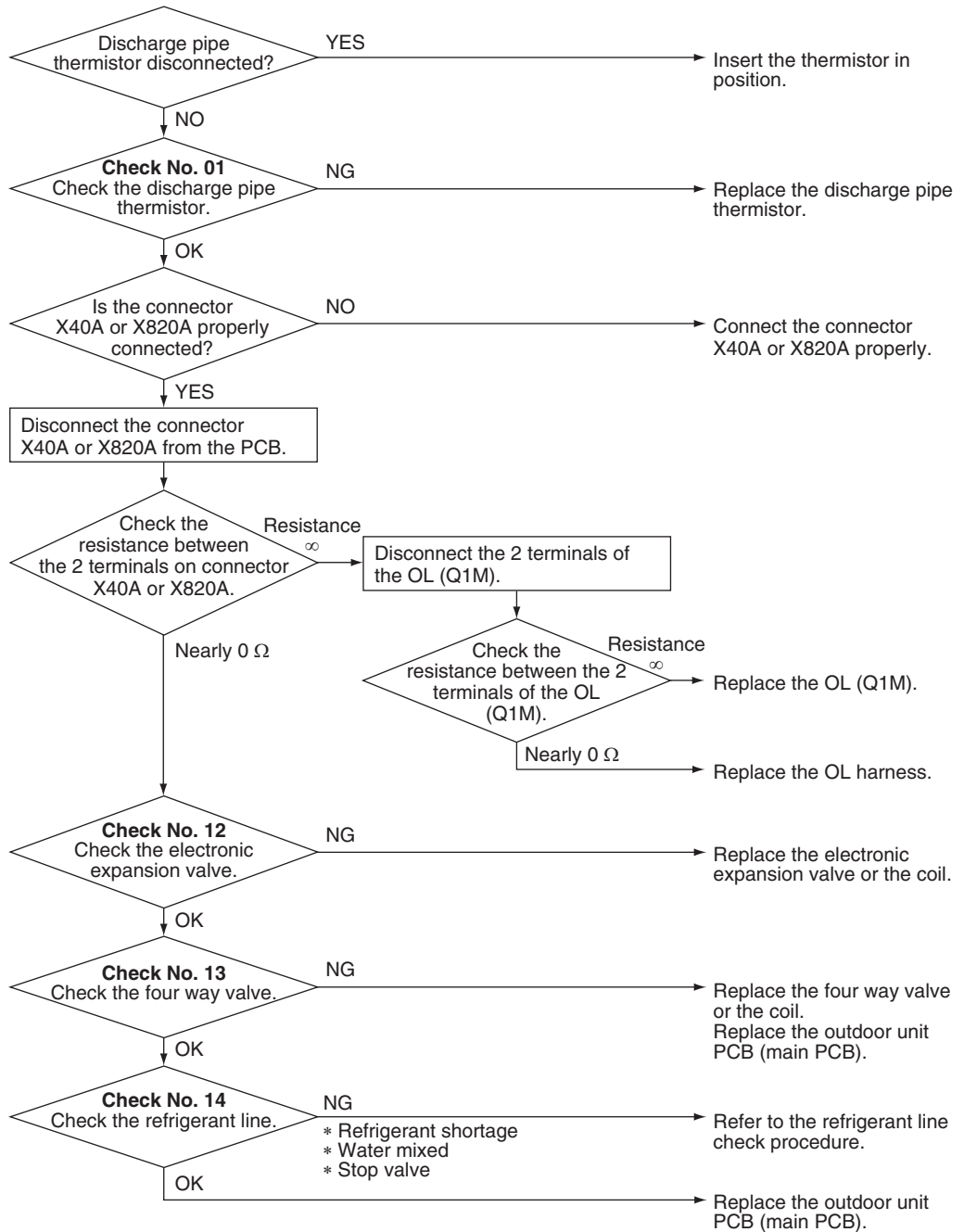

 **Caution** Be sure to turn off the power switch before connecting or disconnecting connectors, or parts may be damaged.



R6001216

 **Notes**

OL (Q1M) activating temperature: 120 ~ 130°C (248 ~ 266°F)
 OL (Q1M) activating temperature: 110°C (230°F)

-  **Reference** **Check No.01** Refer to P.117
-  **Reference** **Check No.12** Refer to P.119
-  **Reference** **Check No.13** Refer to P.120
-  **Reference** **Check No.14** Refer to P.120

6.4 Compressor Lock

| | |
|----------------------------------|---|
| Error Code | E6 |
| Method of Error Detection | A compressor lock is detected by the current waveform generated when applying high-frequency voltage to the motor. |
| Error Decision Conditions | <ul style="list-style-type: none"> ■ If the error repeats, the system is shut down. ■ Reset condition: Continuous run for about 11 minutes without any other error |
| Supposed Causes | <ul style="list-style-type: none"> ■ Closed stop valve ■ Compressor locked ■ Disconnection of compressor harness ■ Defective electronic expansion valve |

Troubleshooting

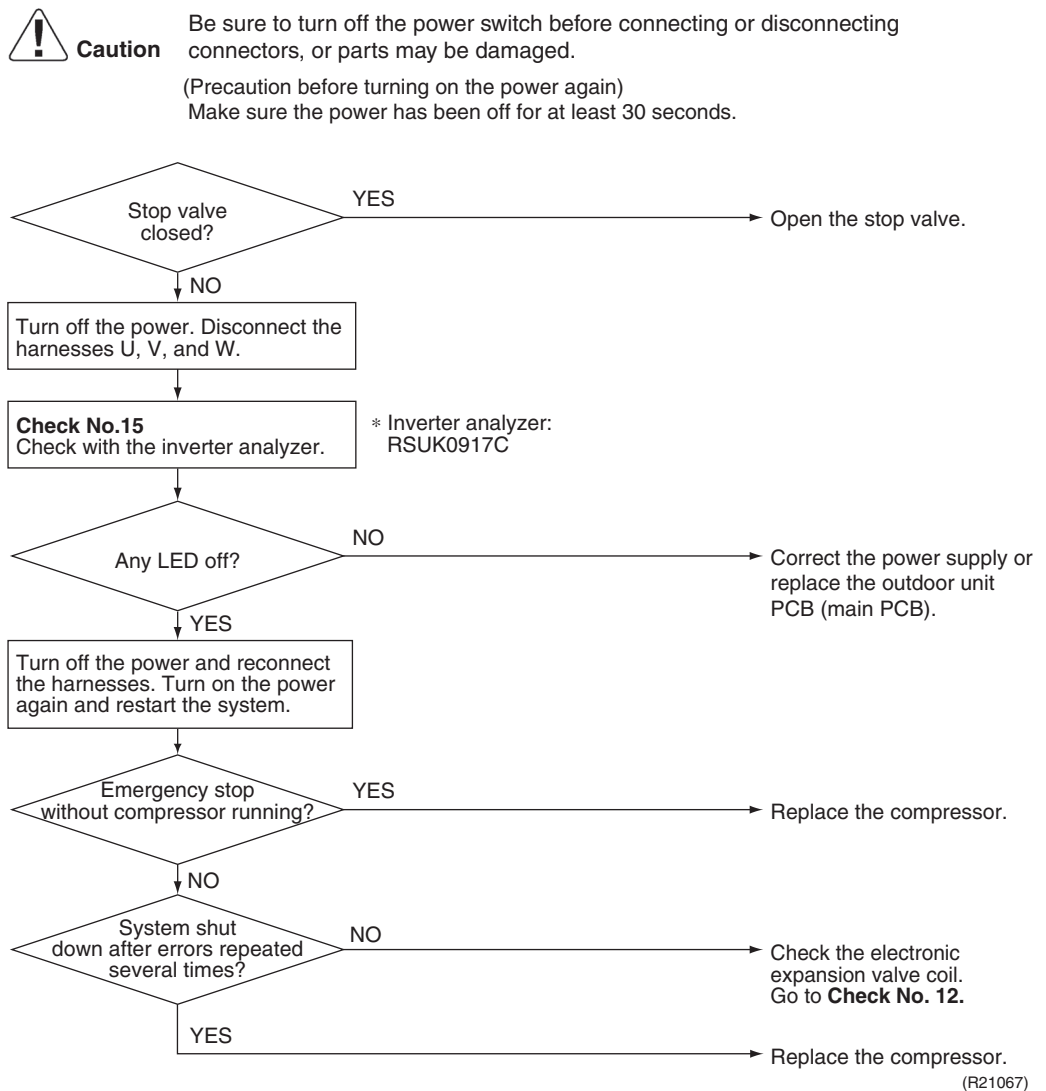

 **Reference** **Check No.12** Refer to P.119

 **Reference** **Check No.15** Refer to P.121

6.5 DC Fan Lock

| | |
|----------------------------------|---|
| Error Code | E7 |
| Method of Error Detection | An error is determined with the high-voltage fan motor rotation speed detected by the Hall IC. |
| Error Decision Conditions | <ul style="list-style-type: none"> ■ The fan does not start in 15 ~ 30 seconds even when the fan motor is running. ■ If the error repeats, the system is shut down. ■ Reset condition: Continuous run for about 11 minutes without any other error |
| Supposed Causes | <ul style="list-style-type: none"> ■ Disconnection of the fan motor ■ Foreign matter stuck in the fan ■ Defective fan motor ■ Defective outdoor unit PCB |

Troubleshooting

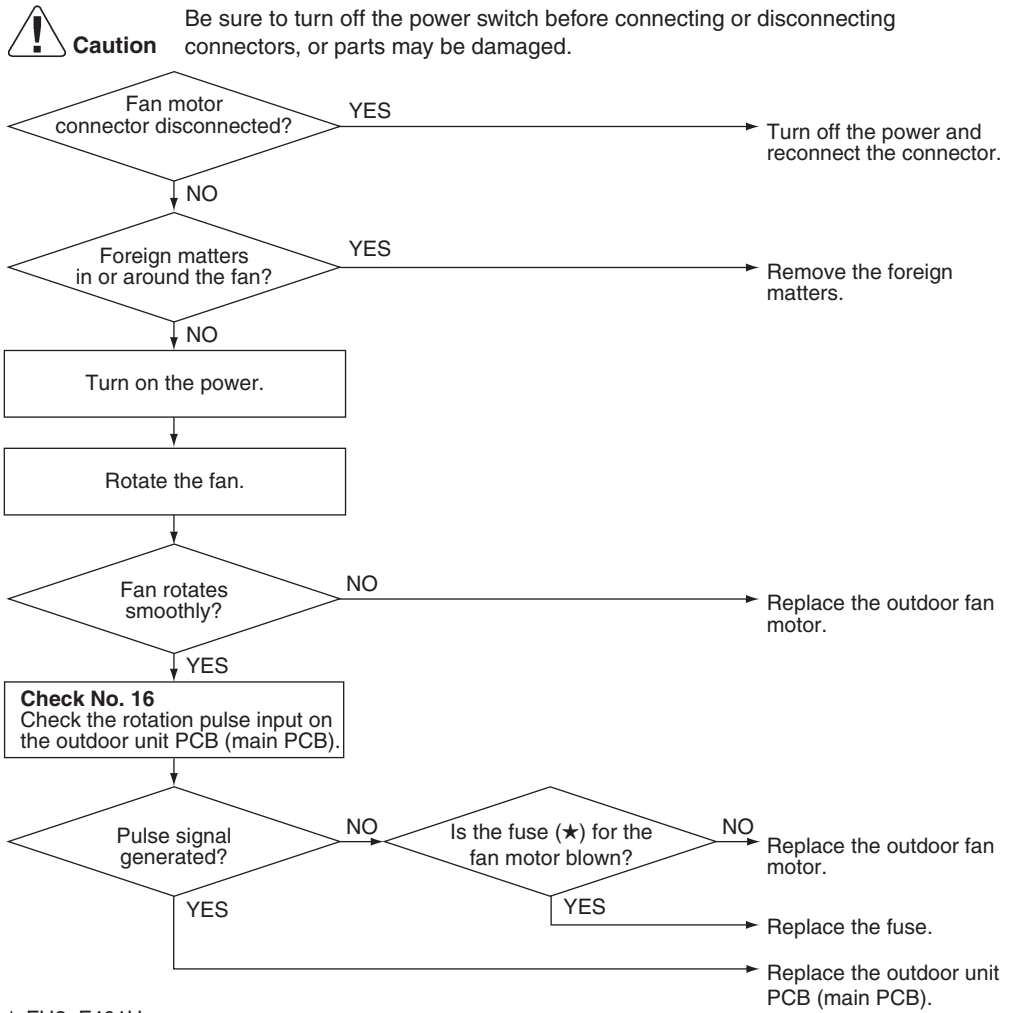

Reference



Check No.16 Refer to P.123

6.6 Input Overcurrent Detection

| | |
|----------------------------------|---|
| Error Code | E8 |
| Method of Error Detection | An input overcurrent is detected by checking the input current value with the compressor running. |
| Error Decision Conditions | The current exceeds about 12.0 ~ 20.0 A (depending on the model) for 2.5 seconds with the compressor running. The upper limit of the current decreases when the outdoor temperature exceeds a certain level. |
| Supposed Causes | <ul style="list-style-type: none"> ■ Outdoor temperature is out of operation range. ■ Defective compressor ■ Defective power module ■ Defective outdoor unit PCB ■ Short circuit |

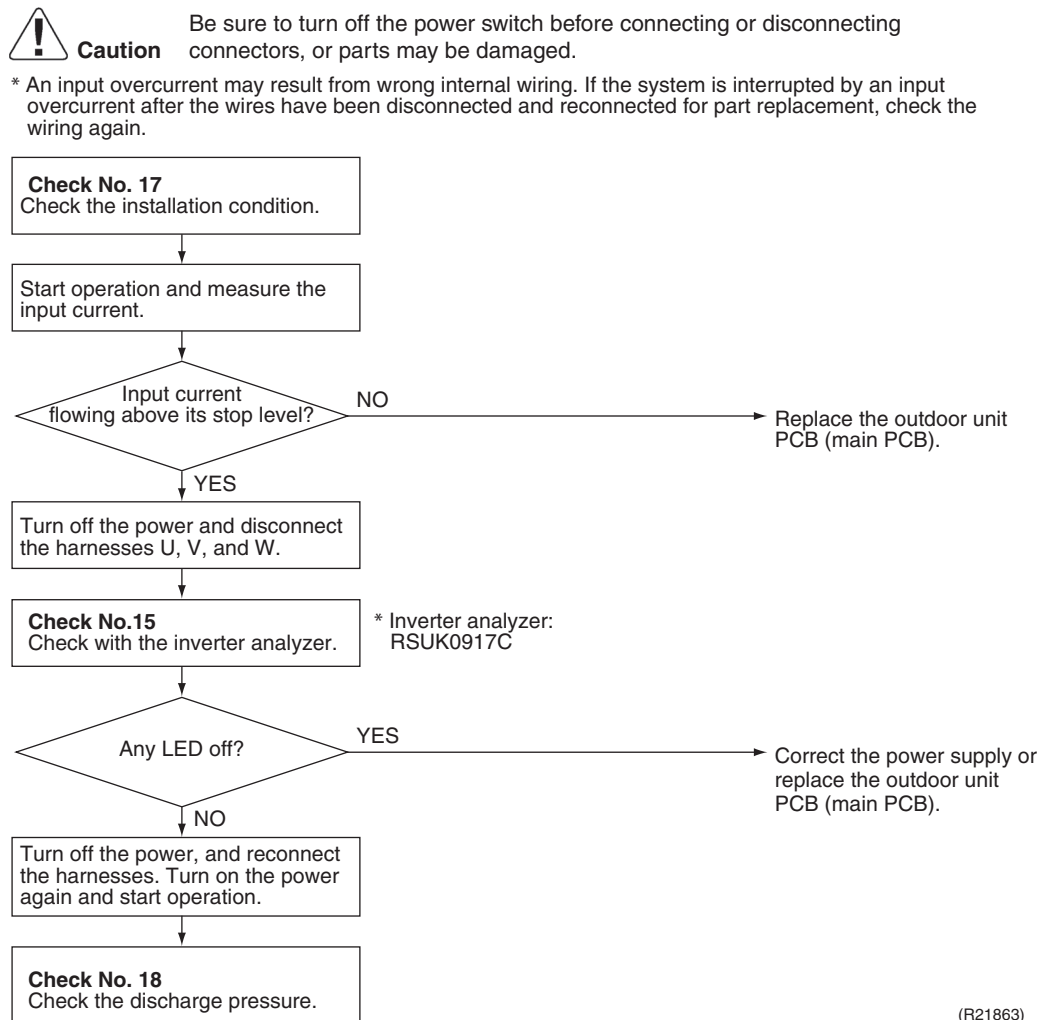
Troubleshooting



-  **Reference** **Check No.15** Refer to P.121
-  **Reference** **Check No.17** Refer to P.123
-  **Reference** **Check No.18** Refer to P.124

6.7 Electronic Expansion Valve Coil Abnormality

| | |
|----------------------------------|---|
| Error Code | E9 |
| Method of Error Detection | Detect errors based on check of continuity of the electronic expansion valve. |
| Error Decision Conditions | <ul style="list-style-type: none"> ■ High input voltage from electronic expansion valve to the microcomputer due to overcurrent. ■ Low input voltage from electronic expansion valve to the microcomputer due to disconnected connectors. |
| Supposed Causes | <ul style="list-style-type: none"> ■ Defective electronic expansion coil ■ Broken harness of electronic expansion coil ■ Defective connection of electronic expansion coil connector ■ Defective outdoor unit main PCB |

Troubleshooting

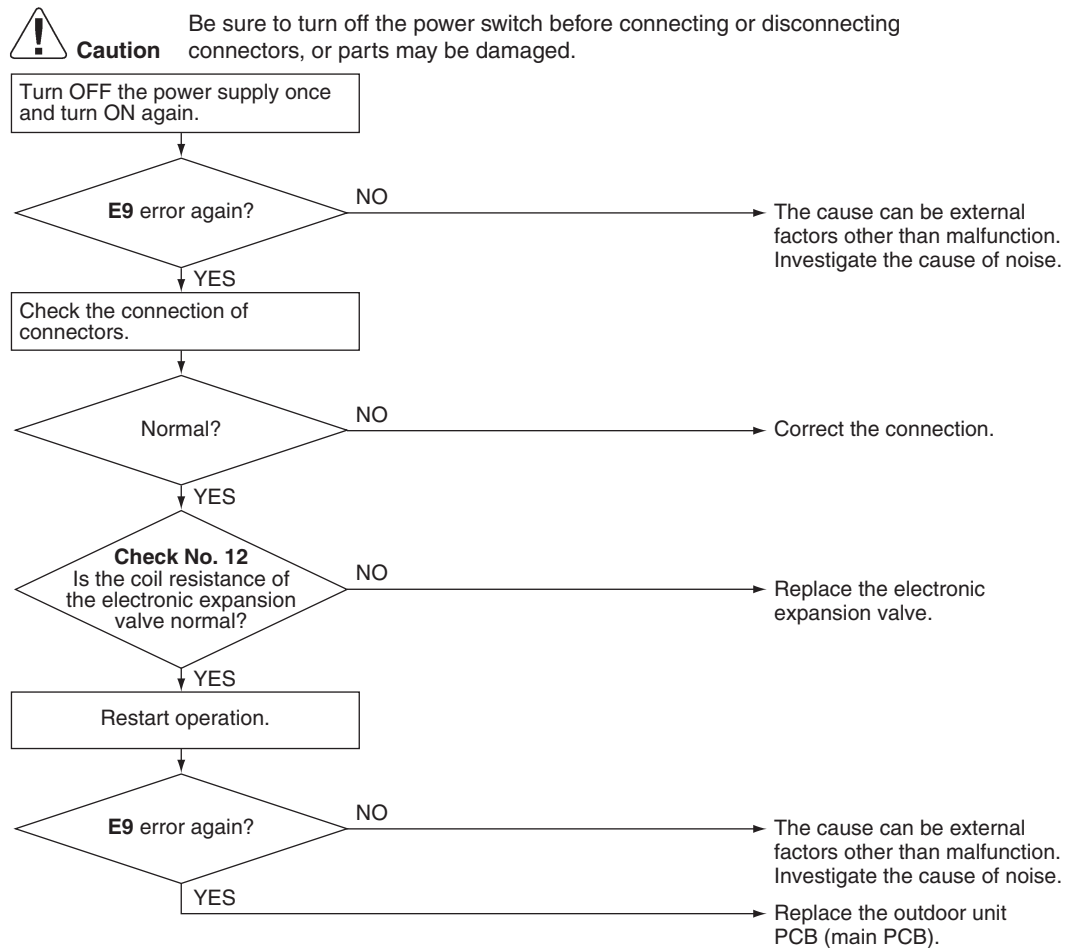

R6001235



Reference

Check No.12 Refer to P.119

6.8 Four Way Valve Abnormality

| Error Code | EA | | | | | | | | | | | | | | | | | | | | | | | | | | | |
|----------------------------------|--|----------|----------|----------|----------|---------------------|-------------|--|--|--|--|----------|----------|----------|----------|----------|-----------------------|-----|-----|-----|-----|-----|------------------------|-----|-----|------|------|------|
| Method of Error Detection | The room temperature thermistor and the indoor heat exchanger thermistor are checked if they function within their normal ranges in each operation mode. | | | | | | | | | | | | | | | | | | | | | | | | | | | |
| Error Decision Conditions | <p>The following condition continues over C seconds after operating for 5 minutes.</p> <ul style="list-style-type: none"> ■ Cooling/Dry $A - B < -5^{\circ}\text{C}$ ($A - B < -9^{\circ}\text{F}$) ■ Heating $B - A < -5^{\circ}\text{C}$ ($B - A < -9^{\circ}\text{F}$) <p>A: Room thermistor temperature B: Indoor heat exchanger temperature</p> <table border="1" style="width: 100%; border-collapse: collapse; text-align: center;"> <thead> <tr> <th rowspan="2">Outdoor temperature</th> <th colspan="5">C (seconds)</th> </tr> <tr> <th>09 class</th> <th>12 class</th> <th>15 class</th> <th>18 class</th> <th>24 class</th> </tr> </thead> <tbody> <tr> <td>-15°C (5°F) or higher</td> <td>300</td> <td>300</td> <td>300</td> <td>300</td> <td>300</td> </tr> <tr> <td>Lower than -15°C (5°F)</td> <td>600</td> <td>300</td> <td>1400</td> <td>1400</td> <td>1400</td> </tr> </tbody> </table> | | | | | Outdoor temperature | C (seconds) | | | | | 09 class | 12 class | 15 class | 18 class | 24 class | -15°C (5°F) or higher | 300 | 300 | 300 | 300 | 300 | Lower than -15°C (5°F) | 600 | 300 | 1400 | 1400 | 1400 |
| Outdoor temperature | C (seconds) | | | | | | | | | | | | | | | | | | | | | | | | | | | |
| | 09 class | 12 class | 15 class | 18 class | 24 class | | | | | | | | | | | | | | | | | | | | | | | |
| -15°C (5°F) or higher | 300 | 300 | 300 | 300 | 300 | | | | | | | | | | | | | | | | | | | | | | | |
| Lower than -15°C (5°F) | 600 | 300 | 1400 | 1400 | 1400 | | | | | | | | | | | | | | | | | | | | | | | |
| Supposed Causes | <ul style="list-style-type: none"> ■ If the error repeats, the system is shut down. ■ Reset condition: Continuous run for about 60 minutes without any other error <hr/> <ul style="list-style-type: none"> ■ Disconnection of four way valve coil ■ Defective four way valve, coil, or harness ■ Defective outdoor unit PCB ■ Defective thermistor(s) ■ Refrigerant shortage ■ Water mixed in refrigerant ■ Defective stop valve | | | | | | | | | | | | | | | | | | | | | | | | | | | |

Troubleshooting



Caution Be sure to turn off the power switch before connecting or disconnecting connectors, or parts may be damaged.

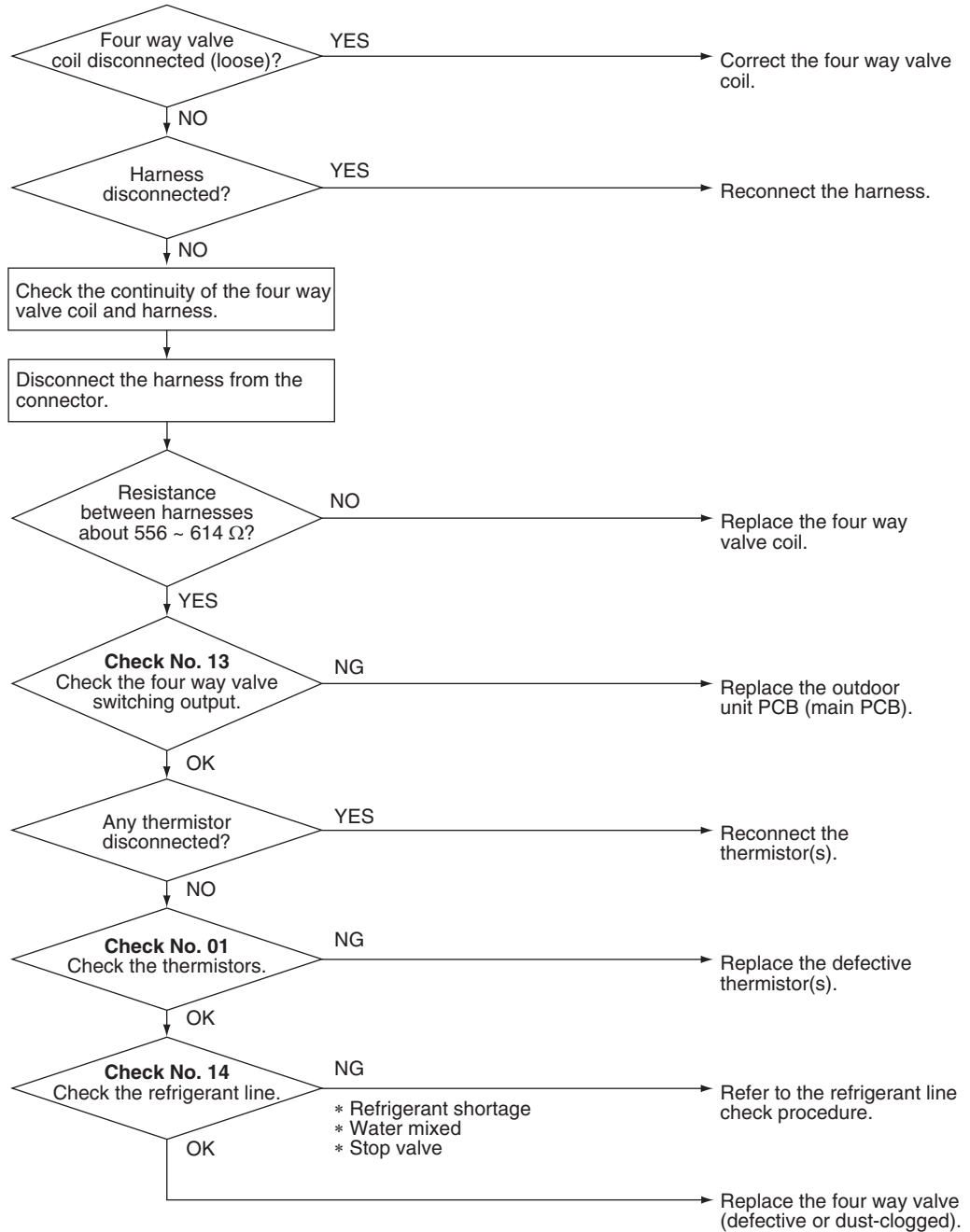

R6001164



Reference Check No.01 Refer to P.117



Reference Check No.13 Refer to P.120







Reference Check No.14 Refer to P.120

6.9 Discharge Pipe Temperature Control

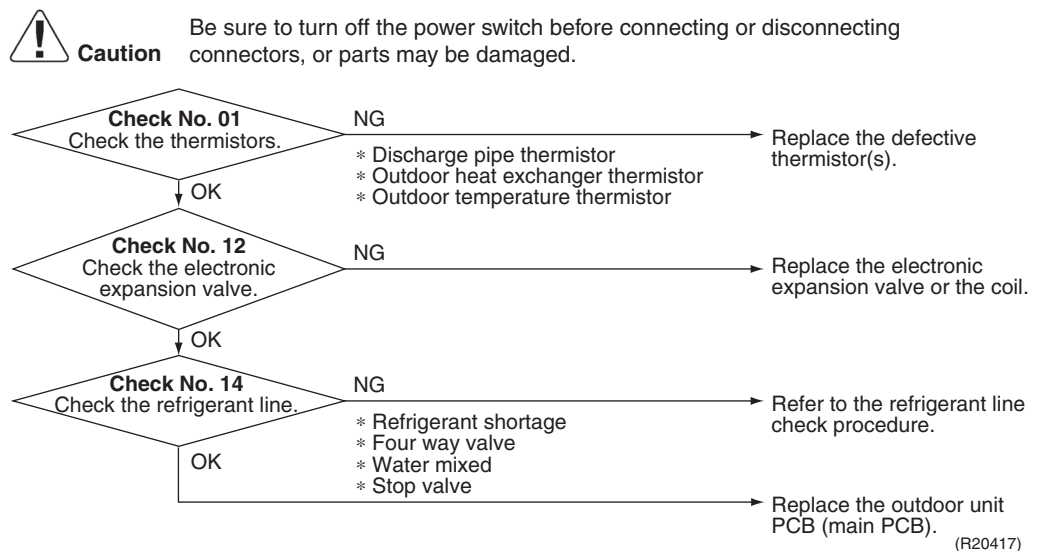
| Error Code | F3 | | | | | | | | | | | | | | | | | | | | | | | | |
|----------------------------------|--|-------|----|-------|---|--|----|----|----|----|----------|-----|-----|----|-------|----------|-----|-------|----|-------|----------------|-----|-------|----|-----|
| Method of Error Detection | An error is determined with the temperature detected by the discharge pipe thermistor. | | | | | | | | | | | | | | | | | | | | | | | | |
| Error Decision Conditions | <ul style="list-style-type: none"> ■ If the temperature detected by the discharge pipe thermistor rises above A, the compressor stops. ■ The error is cleared when the discharge pipe temperature has dropped below B. ■ If the error repeats, the system is shut down. ■ Reset condition: Continuous run for about 60 minutes without any other error | | | | | | | | | | | | | | | | | | | | | | | | |
| | <table border="1"> <thead> <tr> <th rowspan="2"></th> <th colspan="2">A</th> <th colspan="2">B</th> </tr> <tr> <th>°C</th> <th>°F</th> <th>°C</th> <th>°F</th> </tr> </thead> <tbody> <tr> <td>09 class</td> <td>110</td> <td>230</td> <td>88</td> <td>190.4</td> </tr> <tr> <td>12 class</td> <td>118</td> <td>244.4</td> <td>79</td> <td>174.2</td> </tr> <tr> <td>15/18/24 class</td> <td>118</td> <td>244.4</td> <td>85</td> <td>185</td> </tr> </tbody> </table> <p>★ If the frequency drops, the temperature is lowered in compensation.</p> | | A | | B | | °C | °F | °C | °F | 09 class | 110 | 230 | 88 | 190.4 | 12 class | 118 | 244.4 | 79 | 174.2 | 15/18/24 class | 118 | 244.4 | 85 | 185 |
| | A | | B | | | | | | | | | | | | | | | | | | | | | | |
| | °C | °F | °C | °F | | | | | | | | | | | | | | | | | | | | | |
| 09 class | 110 | 230 | 88 | 190.4 | | | | | | | | | | | | | | | | | | | | | |
| 12 class | 118 | 244.4 | 79 | 174.2 | | | | | | | | | | | | | | | | | | | | | |
| 15/18/24 class | 118 | 244.4 | 85 | 185 | | | | | | | | | | | | | | | | | | | | | |
| Supposed Causes | <ul style="list-style-type: none"> ■ Defective discharge pipe thermistor (Defective outdoor heat exchanger thermistor or outdoor temperature thermistor) ■ Defective electronic expansion valve or coil ■ Refrigerant shortage ■ Defective four way valve ■ Water mixed in refrigerant ■ Defective stop valve ■ Defective outdoor unit PCB | | | | | | | | | | | | | | | | | | | | | | | | |

Troubleshooting



-  **Reference** **Check No.01** Refer to P.117
-  **Reference** **Check No.12** Refer to P.119
-  **Reference** **Check No.14** Refer to P.120



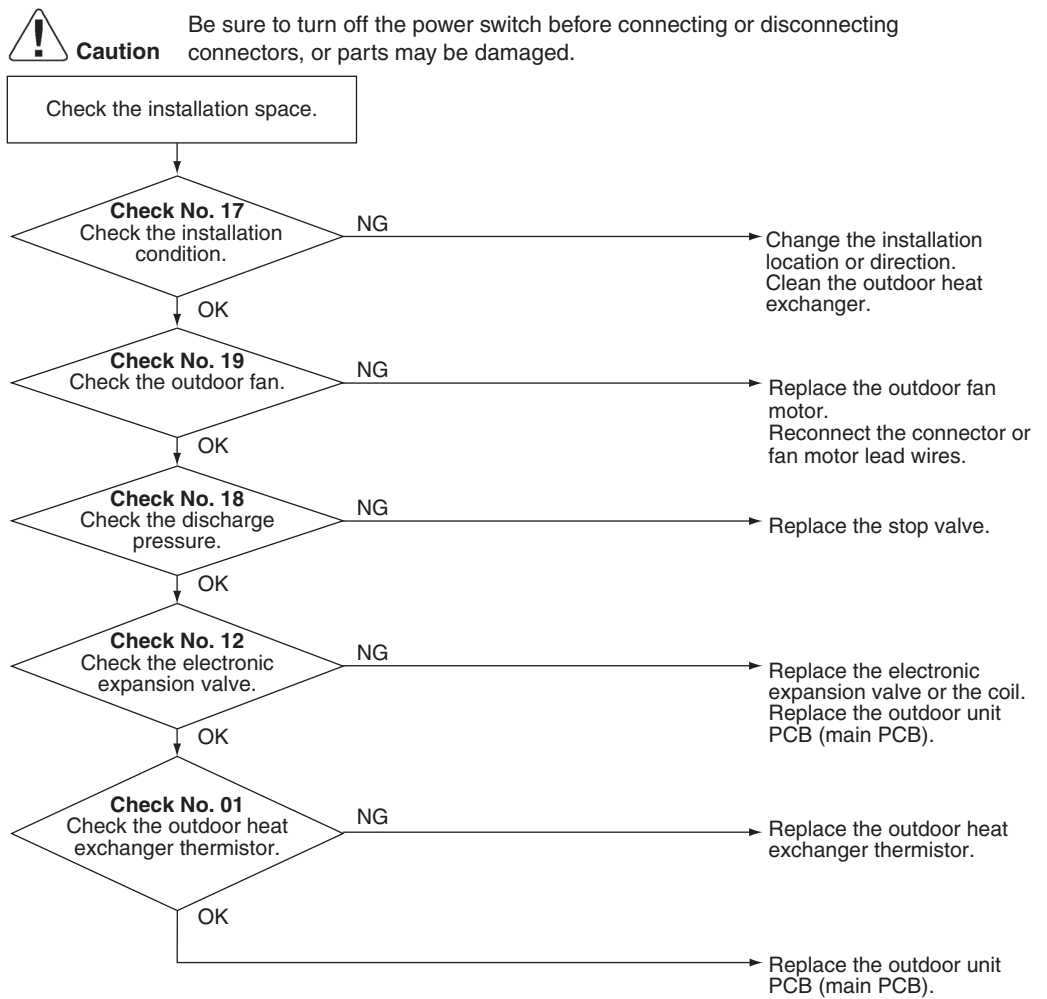

6.10 High Pressure Control in Cooling

| | |
|----------------------------------|---|
| Error Code | F6 |
| Method of Error Detection | High-pressure control (operation halt, frequency drop, etc.) is activated in cooling operation if the temperature sensed by the outdoor heat exchanger thermistor exceeds the limit. |
| Error Decision Conditions | <ul style="list-style-type: none">■ The temperature sensed by the outdoor heat exchanger thermistor rises above 60 ~ 62°C (140 ~ 143.6°F) (depending on the model).■ The error is cleared when the temperature drops below 48.5 ~ 52°C (119.3 ~ 125.6°F) (depending on the model). |
| Supposed Causes | <ul style="list-style-type: none">■ Installation space not large enough■ Dirty outdoor heat exchanger■ Defective outdoor fan motor■ Defective stop valve■ Defective electronic expansion valve or coil■ Defective outdoor heat exchanger thermistor■ Defective outdoor unit PCB |

Troubleshooting



(R20418)

-  **Reference** **Check No.01** Refer to P.117
-  **Reference** **Check No.12** Refer to P.119
-  **Reference** **Check No.17** Refer to P.123
-  **Reference** **Check No.18** Refer to P.124
-  **Reference** **Check No.19** Refer to P.124

6.11 System Shutdown due to Temperature Abnormality in the Compressor

Error Code

F8

Method of Error Detection

Operation is halted when the temperature detected by the discharge pipe thermistor exceeds the determined limit.

Error Decision Conditions

Temperature exceeds the detection threshold of 127.5°C (261.5°F) during forced cooling operation.

Supposed Causes

- Abnormal operation due to air intrusion
- Defective discharge pipe thermistor

Troubleshooting



Caution

Be sure to turn off the power switch before connecting or disconnecting connectors, or parts may be damaged.

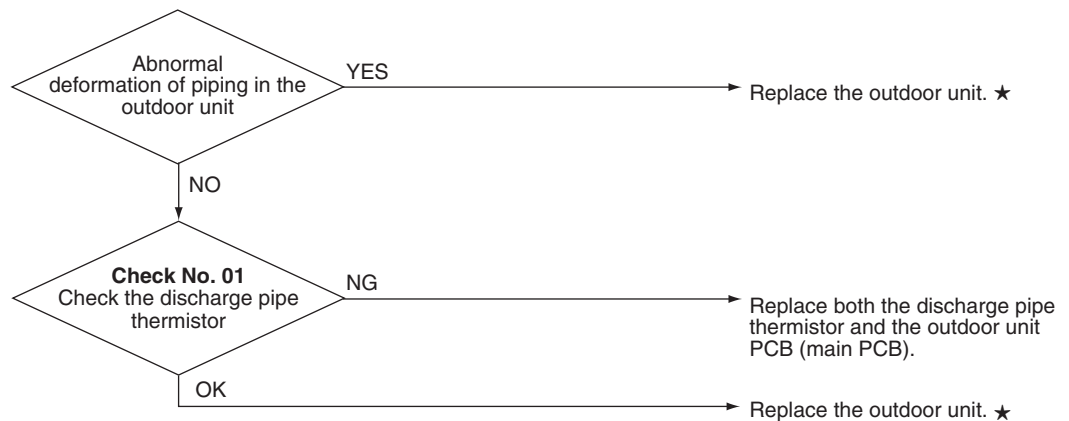

★ Replace the unit as directed in the installation manual, making sure that air does not intrude into the refrigerant piping.

(R23655)



Reference

Check No.01 Refer to P.117

6.12 Compressor Sensor System Abnormality

| | |
|----------------------------------|---|
| Error Code | H0 |
| Method of Error Detection | The system checks the DC current before the compressor starts. |
| Error Decision Conditions | <ul style="list-style-type: none"> ■ The voltage converted from the DC current before compressor start-up is out of the range 0.5 ~ 4.5 V. ■ The DC voltage before compressor start-up is below 50 V. |
| Supposed Causes | <ul style="list-style-type: none"> ■ Broken or disconnected harness ■ Defective outdoor unit PCB |

Troubleshooting

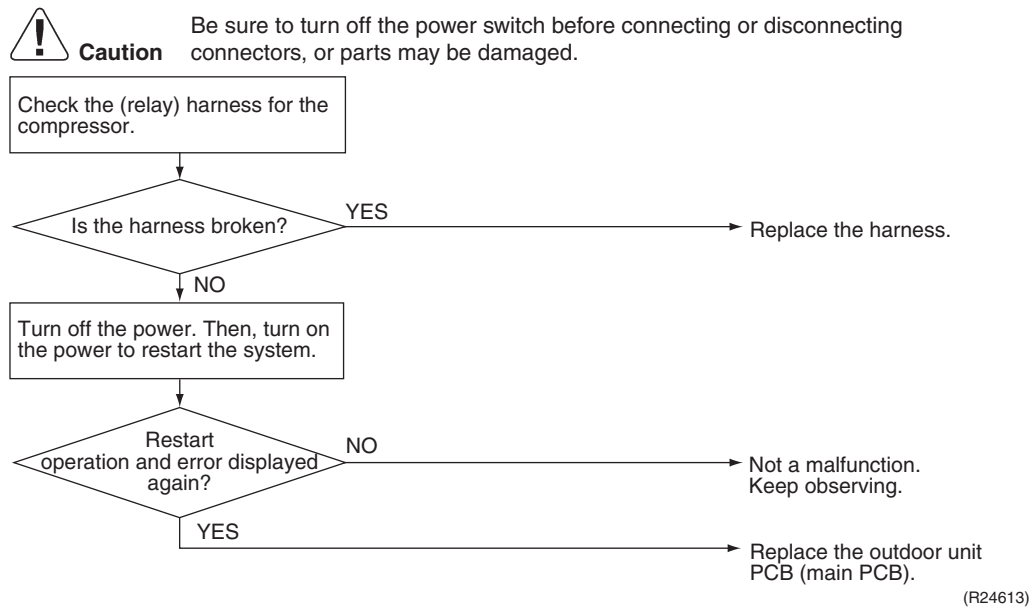

6.13 High Pressure Switch System Abnormality

| | |
|----------------------------------|---|
| Error Code | H3 |
| Method of Error Detection | The protection device circuit checks continuity in the high pressure switch. |
| Error Decision Conditions | There is no continuity in the high pressure switch when the compressor stops operating. |
| Supposed Causes | <ul style="list-style-type: none"> ■ Defective high pressure switch ■ Defective connection of high pressure switch connector ■ Defective outdoor unit main PCB ■ Disconnected lead wire |

Troubleshooting

 **Caution** Be sure to turn off the power switch before connecting or disconnecting connectors, or parts may be damaged.

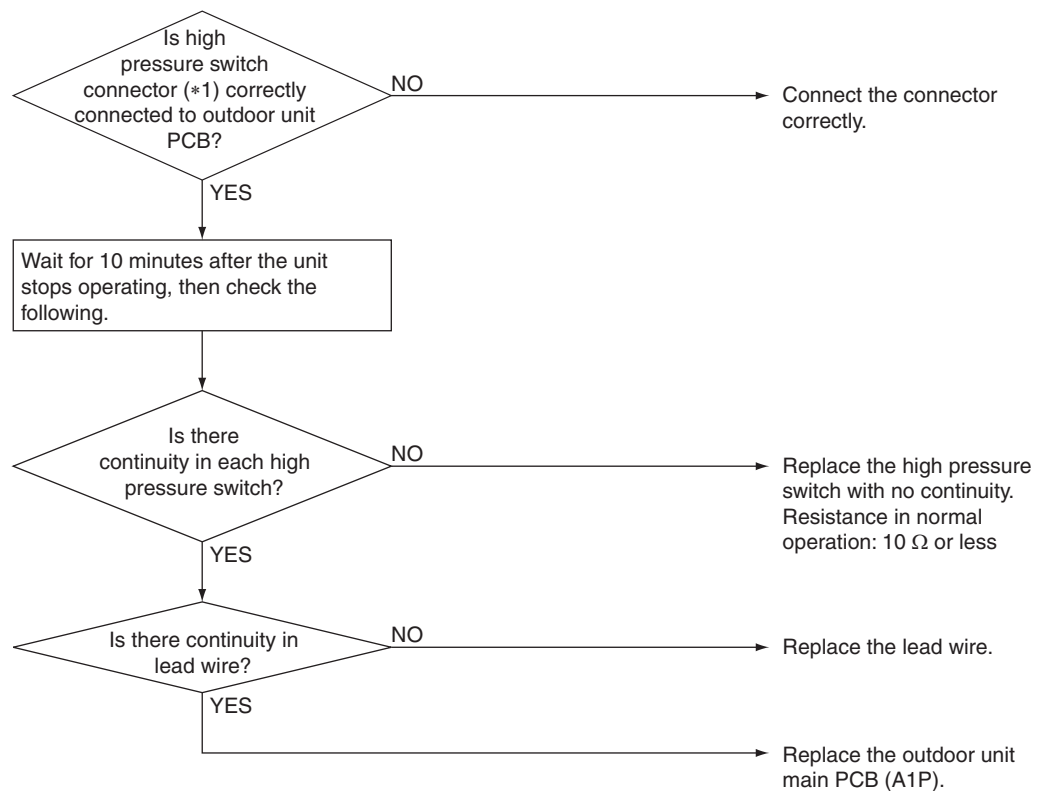

R6001112

 **Note(s)** *1. Connector and high pressure switch

| High pressure switch | Connector for high pressure switch | Activation pressure |
|----------------------|------------------------------------|---------------------|
| S1PH | X40A or X820A | 4.15 MPa (602 psi) |

6.14 Position Sensor Abnormality

| | |
|----------------------------------|--|
| Error Code | H6 |
| Method of Error Detection | A compressor start-up failure is detected by checking the compressor running condition through the position detection circuit. |
| Error Decision Conditions | <ul style="list-style-type: none">■ If the error repeats, the system is shut down.■ Reset condition: Continuous run for about 11 minutes without any other error |
| Supposed Causes | <ul style="list-style-type: none">■ Power supply voltage out of specification■ Disconnection of the compressor harness■ Defective compressor■ Defective outdoor unit PCB■ Start-up failure caused by the closed stop valve■ Input voltage outside the specified range |

Troubleshooting

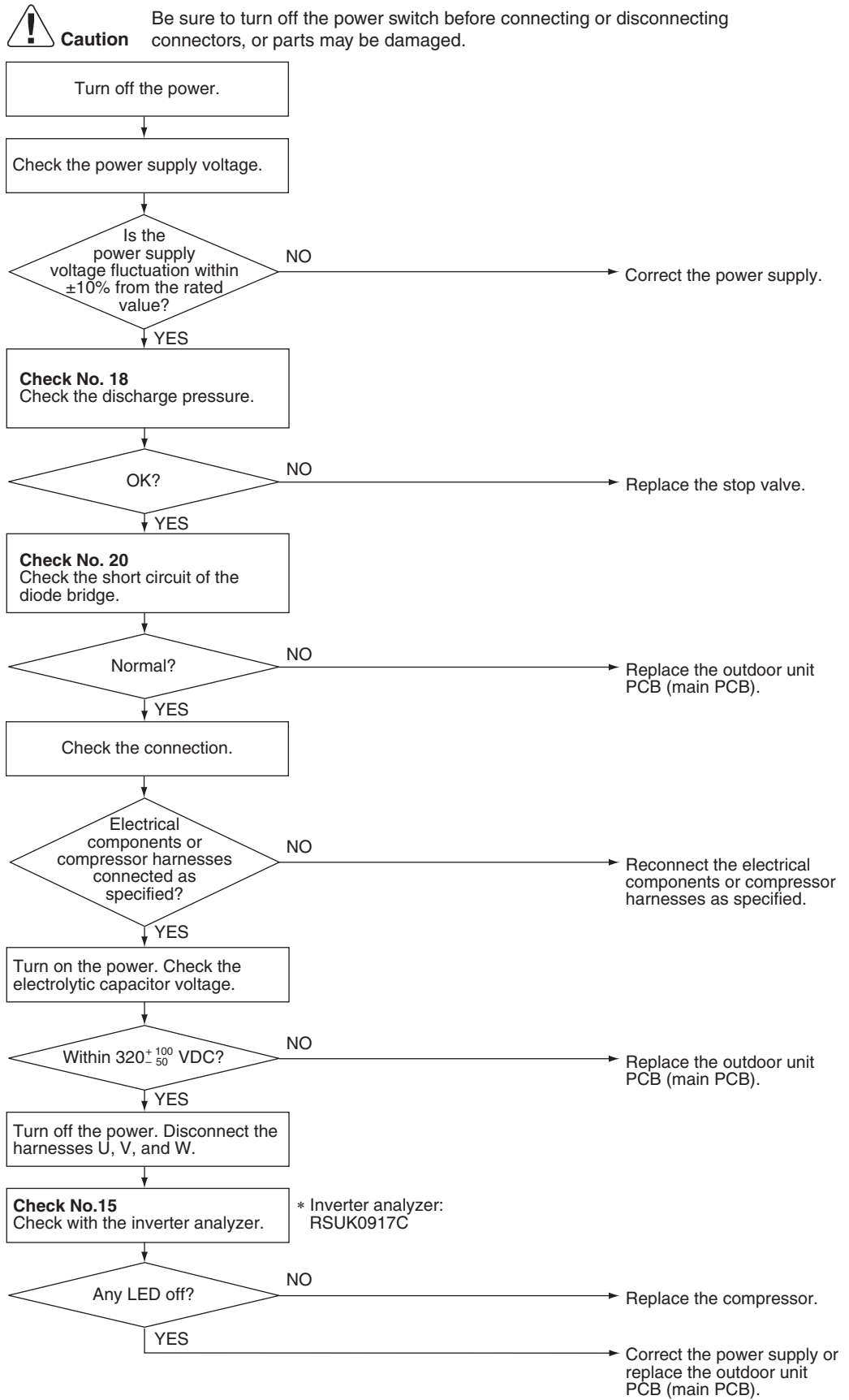

(R22764)

 **Reference** Check No.15 Refer to P.121

 **Reference** Check No.18 Refer to P.124



Reference **Check No.20** Refer to P.125

6.15 Fan IPM temperature error

Applicable Models

RXT15/18/24AVJU9

Error Code

H7

Method of Error Detection

A radiation fin temperature rise is detected by checking the radiation fin temperature with the compressor on.

Error Decision Conditions

- The radiation fin temperature with the compressor on is above **A**.
- The error is cleared when the temperature drops below **B**.
- If the error repeats, the system is shut down.
- Reset condition: Continuous run for about 60 minutes without any other error

| | °C | °F |
|----------|-----|-----|
| A | 100 | 212 |
| B | 90 | 194 |

Supposed Causes

- Defective outdoor fan motor
- Short circuit
- Defective radiation fin thermistor
- Disconnection of connector
- Defective outdoor unit PCB
- Silicone grease not applied properly on the radiation fin after replacing the outdoor unit PCB

Troubleshooting



Caution

Be sure to turn off the power switch before connecting or disconnecting connectors, or parts may be damaged.

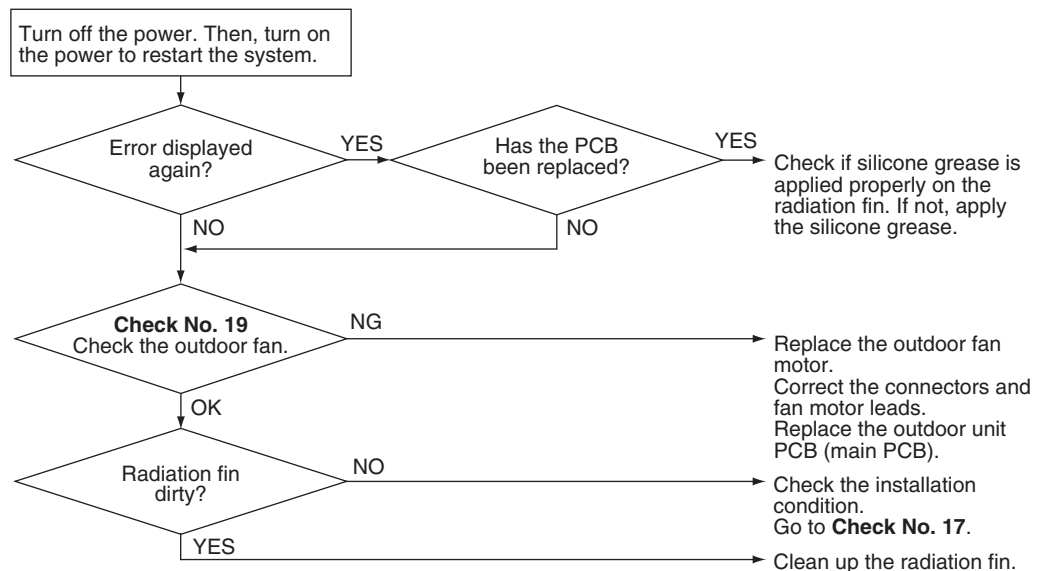

R6001182



Reference

Check No.17 Refer to P.123



Reference

Check No.19 Refer to P.124

6.16 DC Voltage/Current Sensor Abnormality

| | |
|----------------------------------|--|
| Applicable Models | RXT09AVJU9 |
| Error Code | H8 |
| Method of Error Detection | DC voltage or DC current sensor abnormality is identified based on the compressor running frequency and the input current. |
| Error Decision Conditions | <ul style="list-style-type: none"> ■ If the error repeats, the system is shut down. ■ Reset condition: Continuous run for about 60 minutes without any other error |
| Supposed Causes | <ul style="list-style-type: none"> ■ Defective outdoor unit PCB |
| Troubleshooting | |



Caution

Be sure to turn off the power switch before connecting or disconnecting connectors, or parts may be damaged.

Replace the outdoor unit PCB (main PCB).

6.17 Thermistor or Related Abnormality (Outdoor Unit)

| | |
|----------------------------------|--|
| Error Code | H9, J3, J6, P4 |
| Method of Error Detection | This fault is identified based on the thermistor input voltage to the microcomputer. A thermistor fault is identified based on the temperature sensed by each thermistor. |
| Error Decision Conditions | <ul style="list-style-type: none"> ■ The voltage between the both ends of the thermistor is either 4.96 V or more, or 0.04 V or less with the power on. ■ J3 error is judged if the discharge pipe temperature is lower than the heat exchanger temperature. |
| Supposed Causes | <ul style="list-style-type: none"> ■ Disconnection of the connector for the thermistor ■ Defective thermistor(s) ■ Defective heat exchanger thermistor in the case of J3 error (outdoor heat exchanger thermistor in cooling operation, or indoor heat exchanger thermistor in heating operation) ■ Defective outdoor unit PCB |
| Troubleshooting | <p>In case of P4</p> <div style="display: flex; align-items: center; margin-bottom: 10px;"> <div style="text-align: center; margin-right: 10px;">  <p>Caution</p> </div> <div> <p>Be sure to turn off the power switch before connecting or disconnecting connectors, or parts may be damaged.</p> </div> </div> <p>Replace the outdoor unit PCB (main PCB).</p> <p>P4 : Radiation fin thermistor</p> |

Troubleshooting In case of H9, J3, J6



Caution

Be sure to turn off the power switch before connecting or disconnecting connectors, or parts may be damaged.

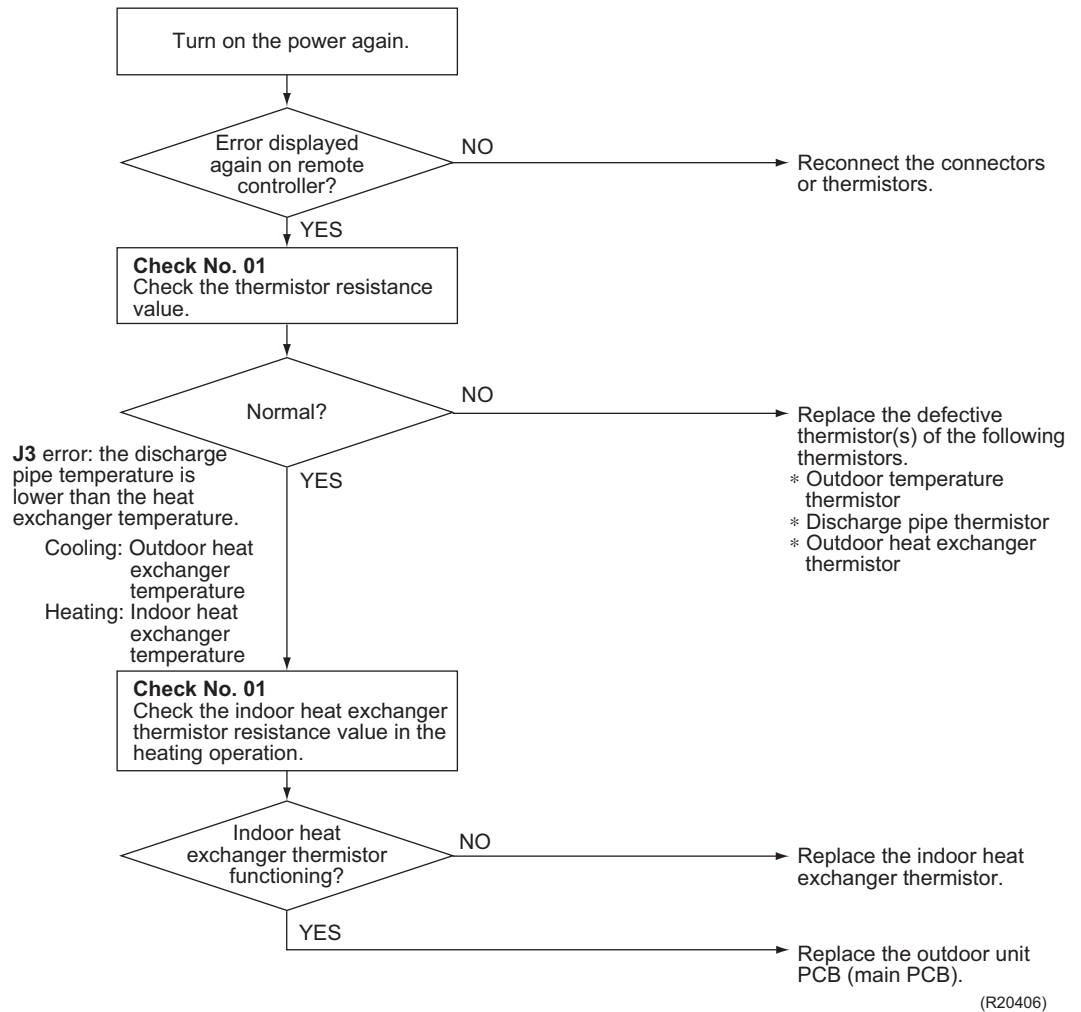

(R20406)

- H9** : Outdoor temperature thermistor
- J3** : Discharge pipe thermistor
- J6** : Outdoor heat exchanger thermistor



Reference

Check No.01 Refer to P.117

6.18 Electrical Box Temperature Rise

| | | | | | | |
|----------------------------------|--|-------|----------|------|----------|-------|
| Error Code | L3 | | | | | |
| Method of Error Detection | An electrical box temperature rise is detected by checking the radiation fin thermistor with the compressor off. | | | | | |
| Error Decision Conditions | <ul style="list-style-type: none"> ■ With the compressor off, the radiation fin temperature is above A. ■ The error is cleared when the radiation fin temperature drops below B. ■ To cool the electrical components, the outdoor fan starts when the radiation fin temperature rises above C and stops when the radiation fin temperature drops below B. | | | | | |
| | A | | B | | C | |
| | (°C) | (°F) | (°C) | (°F) | (°C) | (°F) |
| 09 class | 82 | 179.6 | 65 | 149 | 70 | 158 |
| 12 class | 90 | 194 | 75 | 167 | 81 | 177.8 |
| 15/18/24 class | 100 | 212 | 70 | 158 | 77 | 170.6 |
| Supposed Causes | <ul style="list-style-type: none"> ■ Defective outdoor fan motor ■ Short circuit ■ Defective radiation fin thermistor ■ Disconnection of connector ■ Defective outdoor unit PCB | | | | | |

Troubleshooting

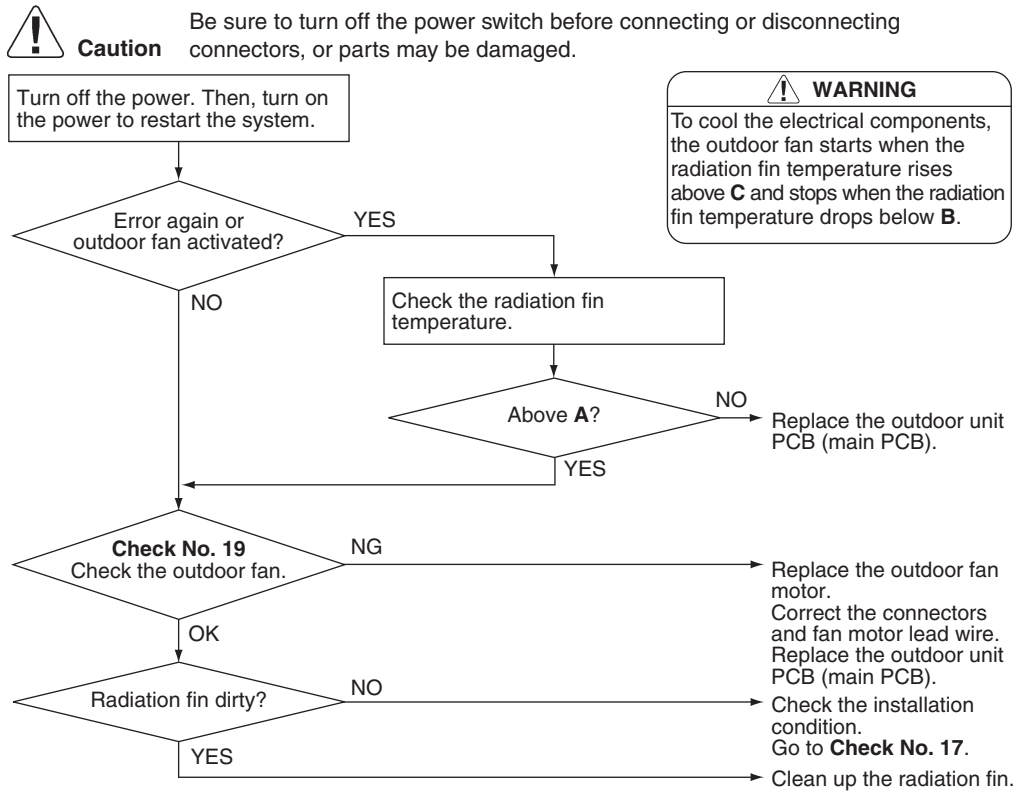

(R22998)

Reference **Check No.17** Refer to P.123

Reference **Check No.19** Refer to P.124

6.19 Radiation Fin Temperature Rise

Error Code **L4**

Method of Error Detection A radiation fin temperature rise is detected by checking the radiation fin thermistor with the compressor on.

Error Decision Conditions

- If the radiation fin temperature with the compressor on is above **A**.
- The error is cleared when the radiation fin temperature drops below **B**.
- If the error repeats, the system is shut down.
- Reset condition: Continuous run for about 60 minutes without any other error

| | A | | B | |
|----------------|----------|-------|----------|-------|
| | (°C) | (°F) | (°C) | (°F) |
| 09 class | 99 | 210.2 | 70 | 158 |
| 12 class | 90 | 194 | 84 | 183.2 |
| 15/18/24 class | 95 | 203 | 85 | 185 |

Supposed Causes

- Defective outdoor fan motor
- Short circuit
- Defective radiation fin thermistor
- Disconnection of connector
- Defective outdoor unit PCB
- Silicone grease not applied properly on the radiation fin after replacing the outdoor unit PCB

Troubleshooting

 **Caution** Be sure to turn off the power switch before connecting or disconnecting connectors, or parts may be damaged.

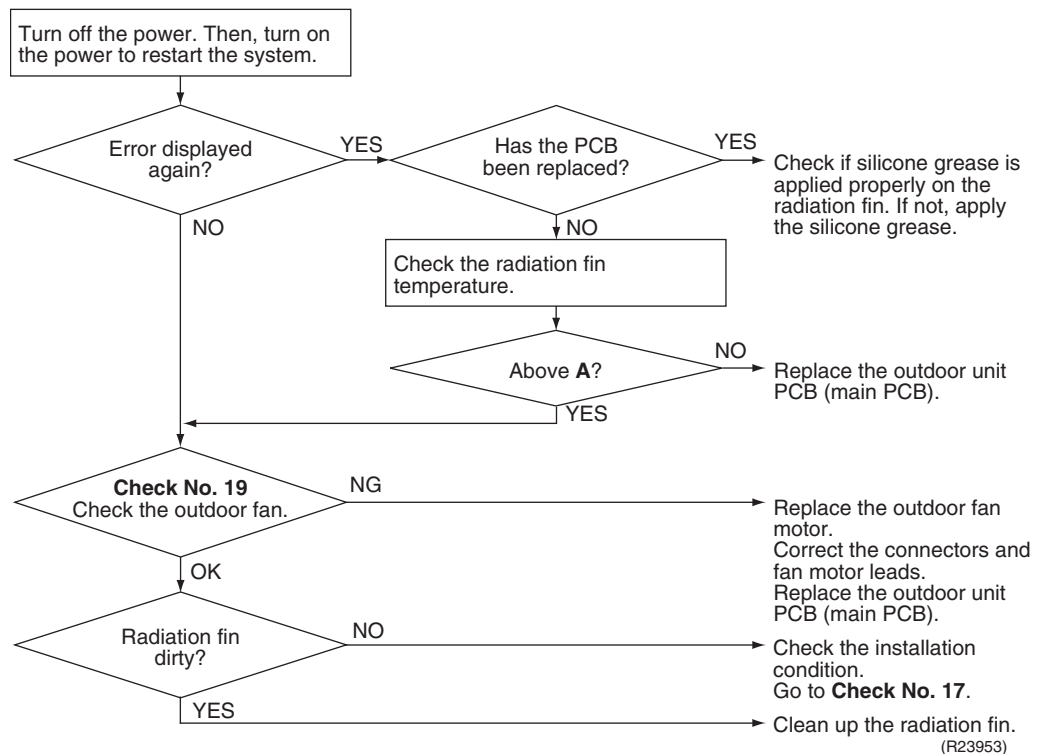

 **Note** Refer to Silicone Grease on Power Transistor/Diode Bridge on page 143 for details.

 **Reference** **Check No.17** Refer to P.123

 **Reference** **Check No.19** Refer to P.124

6.20 Output Overcurrent Detection

| | |
|----------------------------------|--|
| Error Code | L5 |
| Method of Error Detection | An output overcurrent is detected by checking the current that flows in the inverter DC section. |
| Error Decision Conditions | <ul style="list-style-type: none"> ■ A position signal error occurs while the compressor is running. ■ A rotation speed error occurs while the compressor is running. ■ An output overcurrent signal is fed from the output overcurrent detection circuit to the microcomputer. ■ If the error repeats, the system is shut down. ■ Reset condition: Continuous run for about 11 minutes without any other error |
| Supposed Causes | <ul style="list-style-type: none"> ■ Poor installation condition ■ Closed stop valve ■ Defective power module ■ Wrong internal wiring ■ Abnormal power supply voltage ■ Defective outdoor unit PCB ■ Power supply voltage out of specification ■ Defective compressor |

Troubleshooting

 **Caution** Be sure to turn off the power switch before connecting or disconnecting connectors, or parts may be damaged.



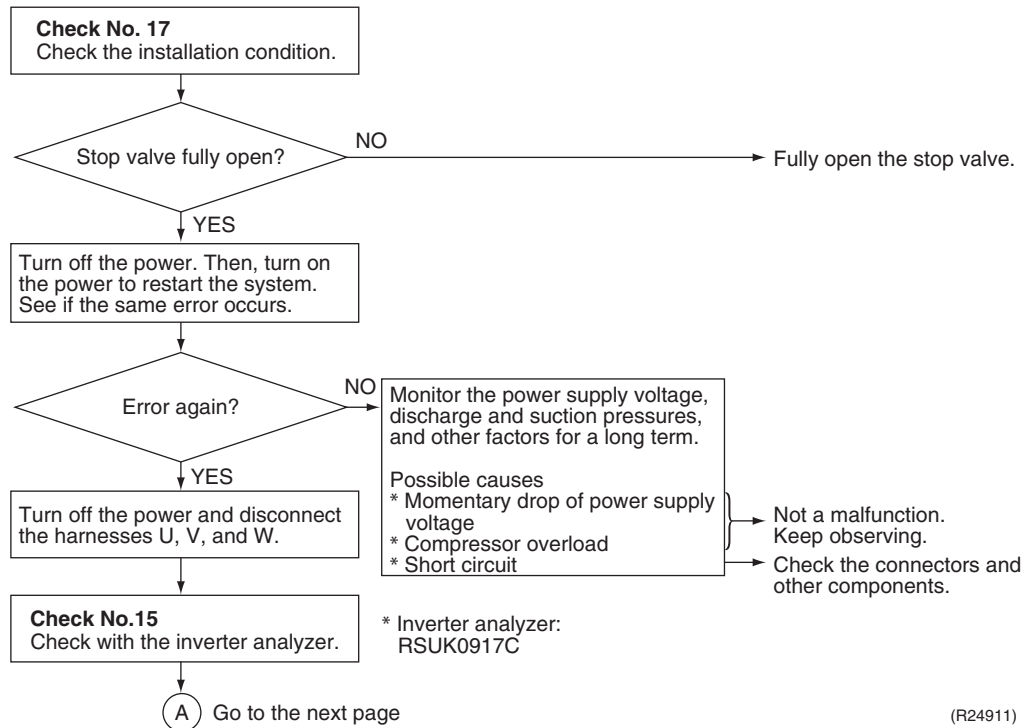

* An output overcurrent may result from wrong internal wiring. If the system is interrupted by an output overcurrent after the wires have been disconnected and reconnected for part replacement, check the wiring again.

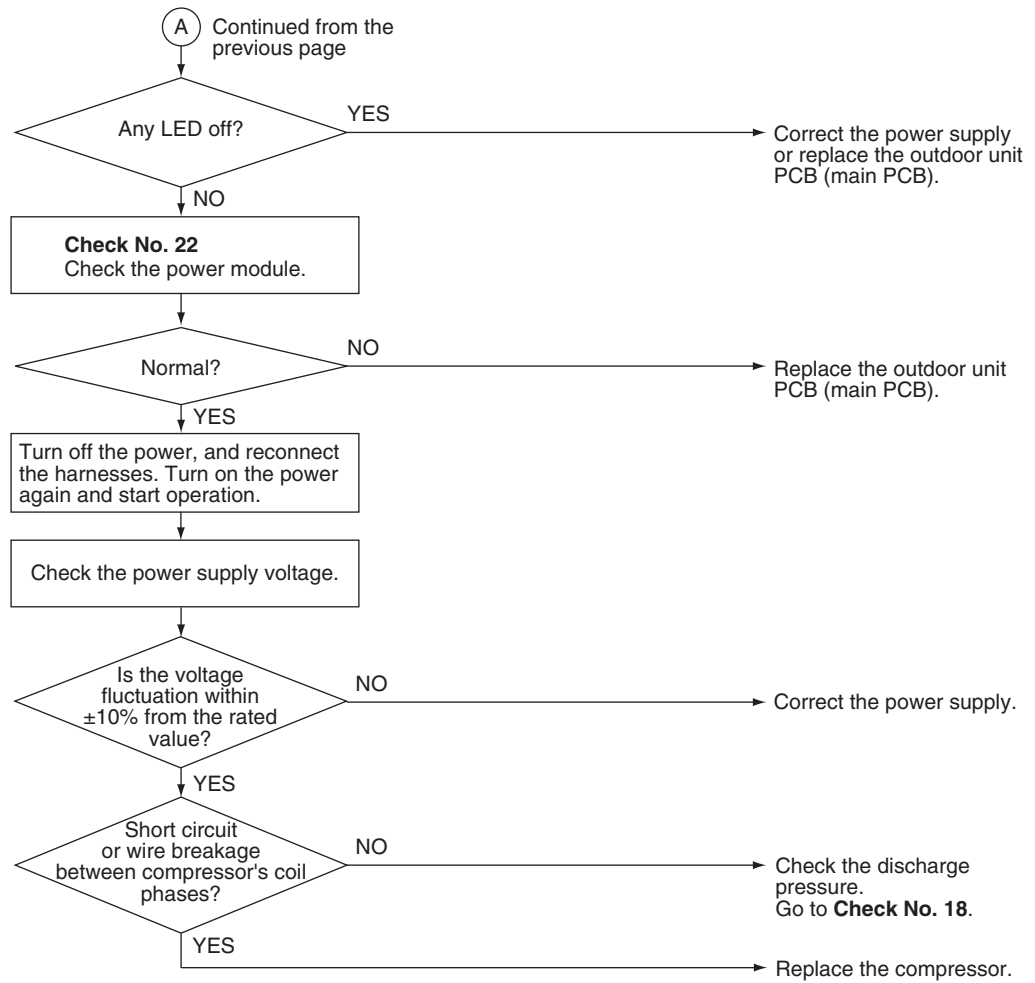

(R24911)



(R24912)

-  **Reference** **Check No.15** Refer to P.121
-  **Reference** **Check No.17** Refer to P.123
-  **Reference** **Check No.18** Refer to P.124
-  **Reference** **Check No.22** Refer to P.127

6.21 IGBT temperature error

Applicable Models

RXT15/18/24AVJU9

Error Code

LA

Method of Error Detection

A radiation fin temperature rise is detected by checking the radiation fin temperature with the compressor on.

Error Decision Conditions

- The radiation fin temperature with the compressor on is above **A**.
- The error is cleared when the temperature drops below **B**.
- If the error repeats, the system is shut down.
- Reset condition: Continuous run for about 60 minutes without any other error

| | °C | °F |
|----------|----|-----|
| A | 90 | 194 |
| B | 85 | 185 |

Supposed Causes

- Defective outdoor fan motor
- Short circuit
- Defective radiation fin thermistor
- Disconnection of connector
- Defective outdoor unit PCB
- Silicone grease not applied properly on the radiation fin after replacing the outdoor unit PCB

Troubleshooting



Caution

Be sure to turn off the power switch before connecting or disconnecting connectors, or parts may be damaged.

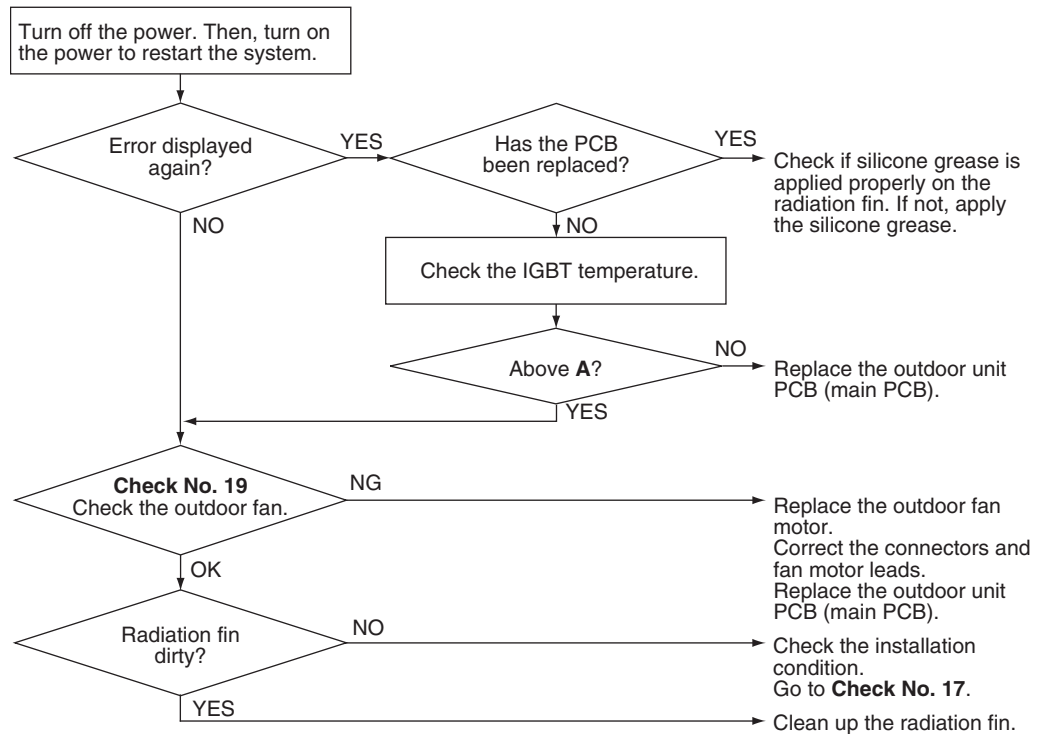

R6001154



Reference

Check No.17 Refer to P.123



Reference

Check No.19 Refer to P.124

6.22 Signal Transmission Error on Outdoor Unit PCB

| | |
|----------------------------------|--|
| Error Code | U7 |
| Method of Error Detection | Communication error between microcomputer mounted on the main PCB and PM1. |
| Error Decision Conditions | <ul style="list-style-type: none"> ■ The abnormality is determined when the data sent from the PM1 cannot be received for 9 seconds. ■ The error counter is reset when the data from the PM1 can be successfully received. |
| Supposed Causes | <ul style="list-style-type: none"> ■ Defective outdoor unit PCB |

Troubleshooting



Caution

Be sure to turn off the power switch before connecting or disconnecting connectors, or parts may be damaged.

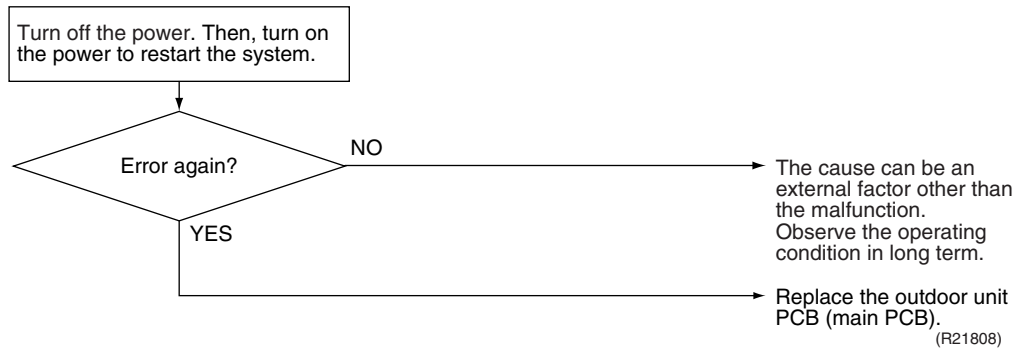

7. Check

7.1 Thermistor Resistance Check

Check No.01

Measure the resistance of each thermistor using multimeter.

The resistance values are defined by below table.

If the measured resistance value does not match the listed value, the thermistor must be replaced.

- Disconnect the connector of thermistor ASSY from the PCB to measure the resistance between the pins using multimeter.
- To check the thermistor soldered on a PCB, disconnect the PCB from other PCB/parts, and measure the resistance between the both ends of soldered thermistor.

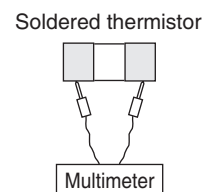
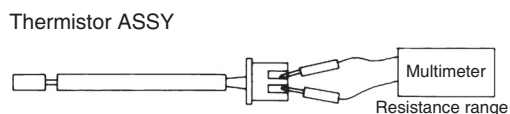

| Thermistor temperature | | Resistance (kΩ) |
|------------------------|-----|---|
| °C | °F | $R(25^{\circ}\text{C} / 77^{\circ}\text{F}) = 20 \text{ k}\Omega$ $B = 3950 \text{ K}$ |
| -20 | -4 | 197.8 |
| -15 | 5 | 148.2 |
| -10 | 14 | 112.1 |
| -5 | 23 | 85.60 |
| 0 | 32 | 65.93 |
| 5 | 41 | 51.14 |
| 10 | 50 | 39.99 |
| 15 | 59 | 31.52 |
| 20 | 68 | 25.02 |
| 25 | 77 | 20.00 |
| 30 | 86 | 16.10 |
| 35 | 95 | 13.04 |
| 40 | 104 | 10.62 |
| 45 | 113 | 8.707 |
| 50 | 122 | 7.176 |

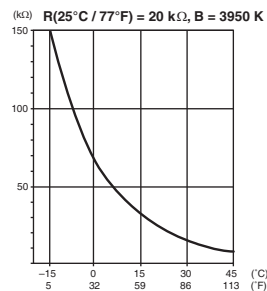

R6001195



Note(s) When replacing the defective thermistor(s), replace the thermistor as ASSY.

7.2 Indoor Fan Motor Connector Check

Check No.03

- Check the connection of connector.
 1. Check connector the for connection.
 2. Turn the power off.
 3. Check if each resistance at the phases U - V and V - W is within specified rage in the table below.

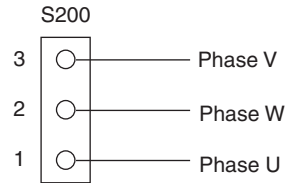

R6001148

| | U - V/V - W Resistance (Ω) |
|----------------|-------------------------------------|
| 09/12 class | 70.9 ~ 78.3 |
| 15/18/24 class | 42.9 ~ 47.5 |

7.3 Power Supply Waveform Check

Check No.11

Measure the power supply waveform between No. 1 and No. 2 on the terminal strip, and check the waveform disturbance.

- Check if the power supply waveform is a sine wave (Fig.1).
- Check if there is waveform disturbance near the zero-cross (sections circled in Fig.2).

[Fig.1]

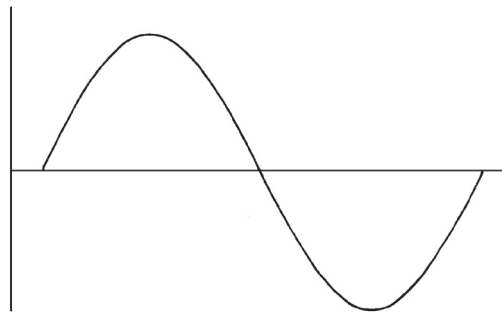

(R1736)

[Fig.2]

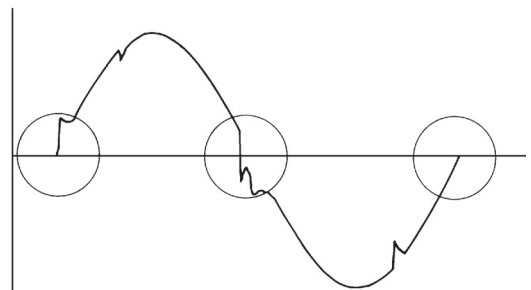

(R1444)

7.4 Electronic Expansion Valve Check

Check No.12

Conduct the following to check the electronic expansion valve (EV).

1. Check if the EV connector is correctly connected to the PCB.
2. Turn the power off and on again, and check if the EV generates a latching sound.
3. If the EV does not generate a latching sound in step 2, disconnect the connector and check the continuity using a multimeter.
4. Check the continuity between the pins 5 - 1, 5 - 2, 5 - 3, 5 - 4. If there is no continuity between the pins, the EV coil is faulty.
5. If the continuity is confirmed in step 3, the outdoor unit PCB (main PCB) is faulty.

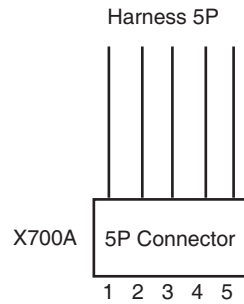

Check {

- 5 - 1
- 5 - 2
- 5 - 3
- 5 - 4

R6000952

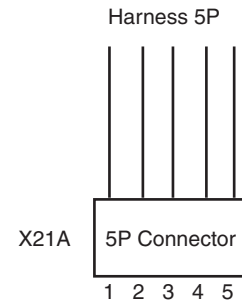

Check {

- 5 - 1
- 5 - 2
- 5 - 3
- 5 - 4

R6001211

7.5 Four Way Valve Performance Check

Check No.13

< Caution on resetting the power supply >

* Be sure to wait for 30 sec. or more after turning off the power.

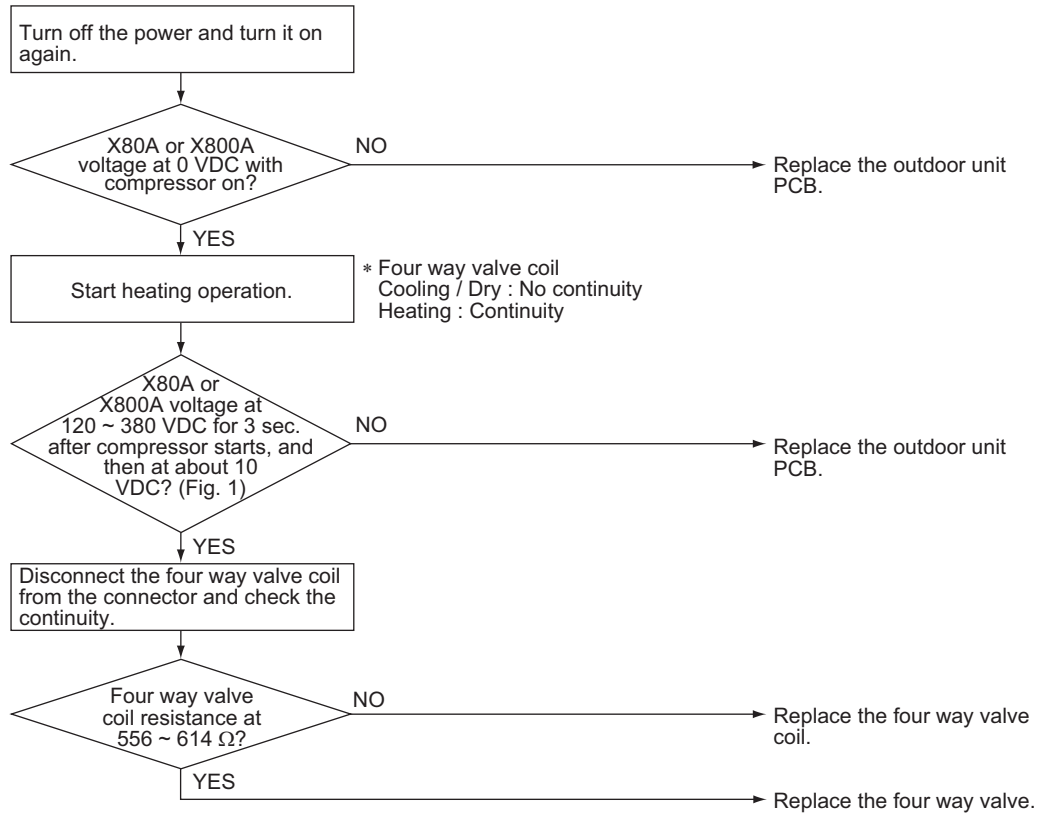

(Fig. 1)

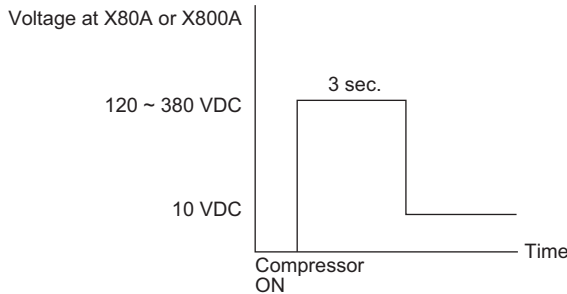

R6001212

7.6 Inverter Unit Refrigerant System Check

Check No.14

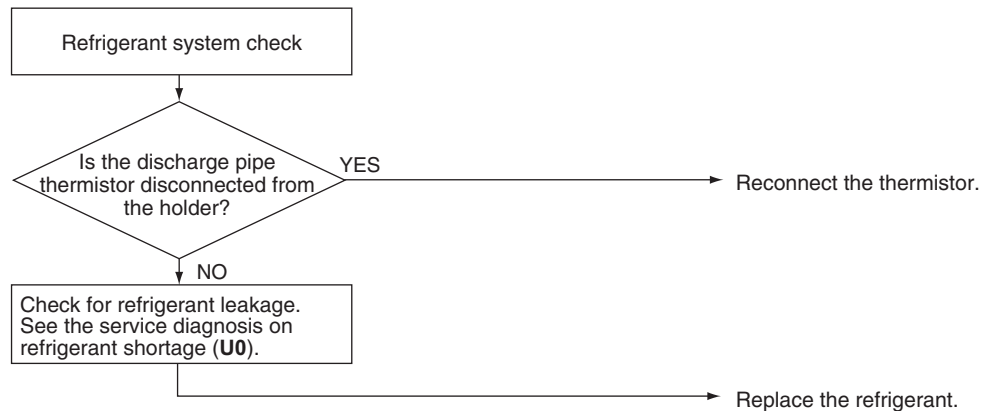

R6000874

7.7 Inverter Analyzer Check

Check No.15

■ Characteristics

Inverter analyzer: RSUK0917C

If an abnormal stop occurs due to compressor startup failure or overcurrent output when using an inverter unit, it is difficult to judge whether the stop is caused by the compressor failure or some other failure (main PCB, power module, etc.). The inverter analyzer makes it possible to judge the cause of trouble easily and securely. Connect an inverter analyzer as a quasi-compressor instead of compressor and check the output of the inverter.

■ Operation Method

Step 1

Be sure to turn the power off.

Step 2

Install an inverter analyzer instead of a compressor.

Note:

Make sure the charged voltage of the built-in smoothing electrolytic capacitor drops to 10 VDC or below before carrying out the service work.

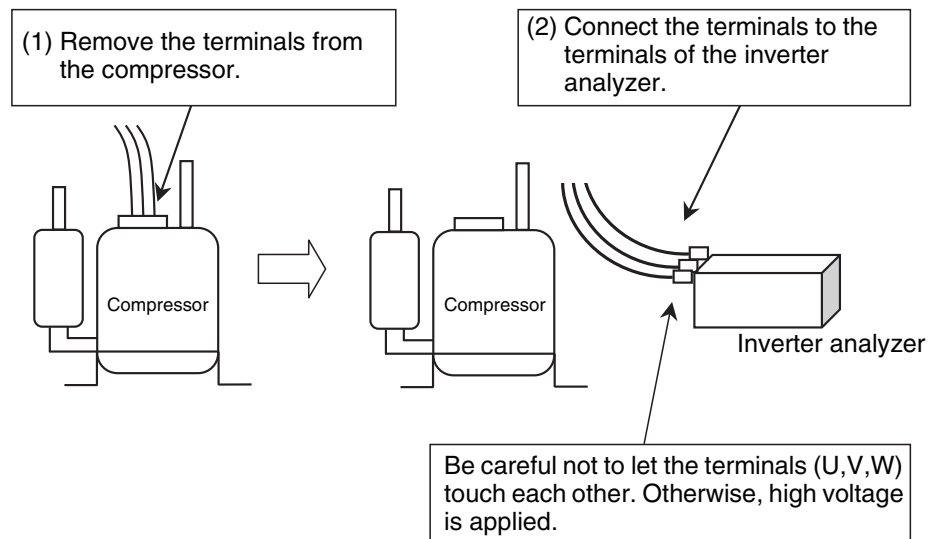

Reference:

If the terminals of the compressor are not FASTON terminals (difficult to remove the wire on the terminals), it is possible to connect wires available on site to the outdoor unit from output side of PCB. Do not connect them to the compressor at the same time, otherwise it may result in incorrect detection.

Step 3

Activate the power transistor test



Note

Power transistor test operation can be activated only once after turning on the power supply. If reactivation of the power supply transistor operation is needed, turn the power supply off and then on again.

1. Turn the power on.
2. Press the center of **TEMP** button and **OFF** button on the remote controller at the same time.
3. Select **T** with **TEMP** ^ or **TEMP** v button.
4. Press **FAN** button.
5. Press **FAN ONLY** button to start the power transistor test operation.

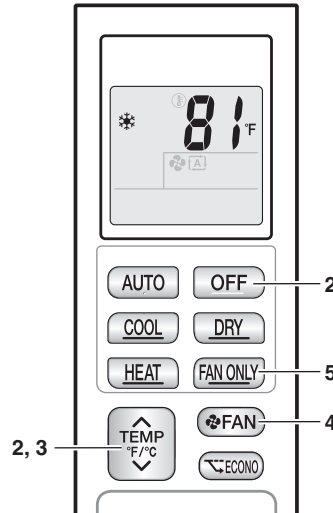

R6000683

■ **Diagnose method (Diagnose according to 6 LEDs lighting status.)**

1. If all the LEDs are lit uniformly, the compressor is defective.
→ Replace the compressor.
2. If the LEDs are not lit uniformly, check the power module.
→ Refer to **Check No.22**.
3. If NG in **Check No.22**, replace the power module.
(Replace the main PCB. The power module (IPM1) is united with the main PCB.)
If OK in **Check No.22**, check if there is any solder cracking on the PCB.
4. If any solder cracking is found, replace the PCB or repair the soldered section.
If there is no solder cracking, replace the PCB.

 **Caution**

1. When the output frequency is low, the LEDs blink slowly. As the output frequency increases, the LEDs blink quicker. (The LEDs look like they are lit.)
2. On completion of the inverter analyzer diagnosis, be sure to re-crimp the FASTON terminals. Otherwise, the terminals may be burned due to loosening.

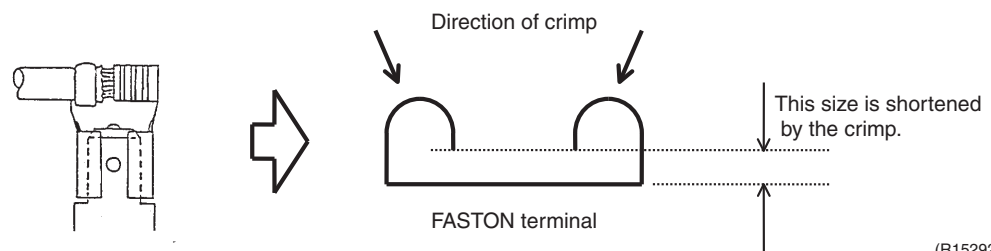

(R15292)

7.8 Outdoor Fan Motor Check

Check No.16

Outdoor fan motor

Check if the sinusoidal voltage is generated between pins 1 - 3 and 3 - 5 when the fan motor is manually rotated once.

■ 09/15/18/24 class

■ 12 class

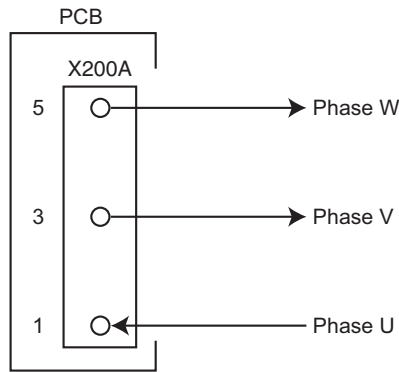

R6001127

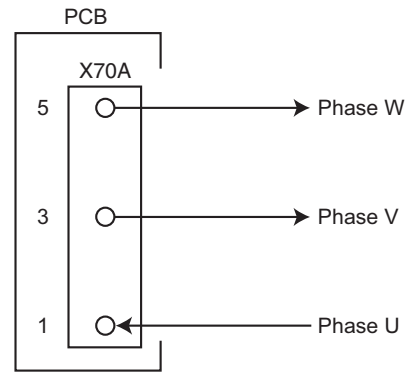

R6001180

7.9 Installation Condition Check

Check No.17

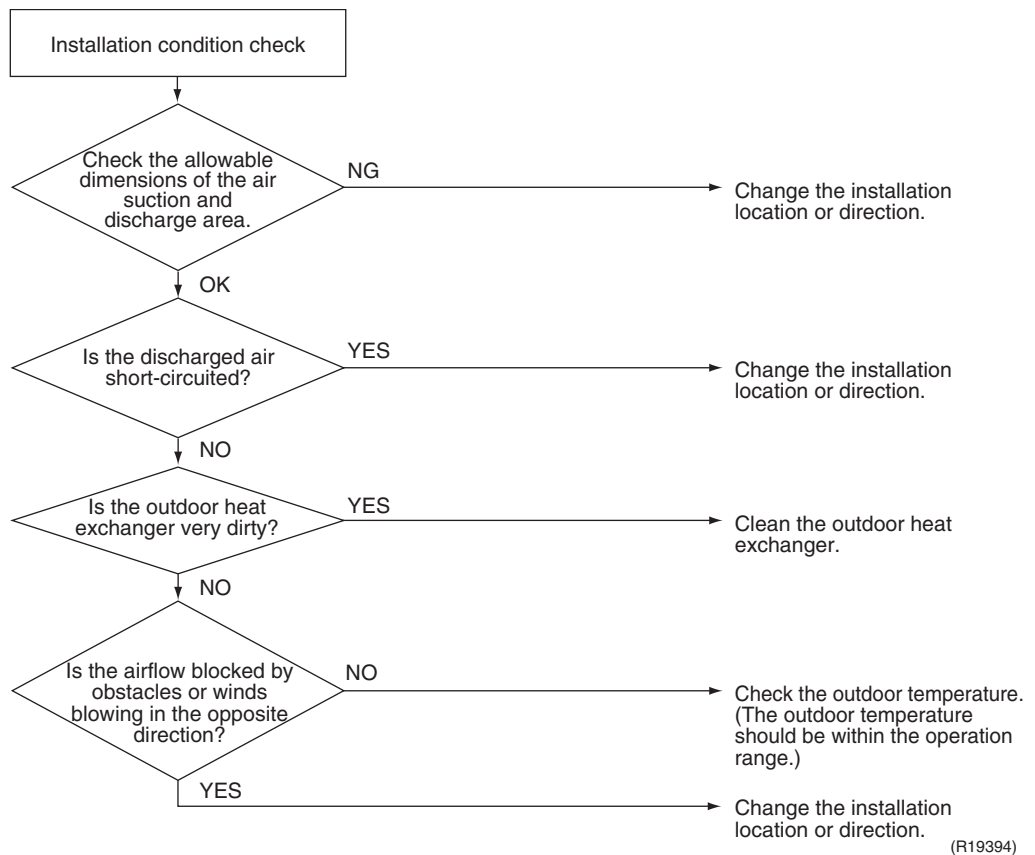

7.10 Discharge Pressure Check

Check No.18

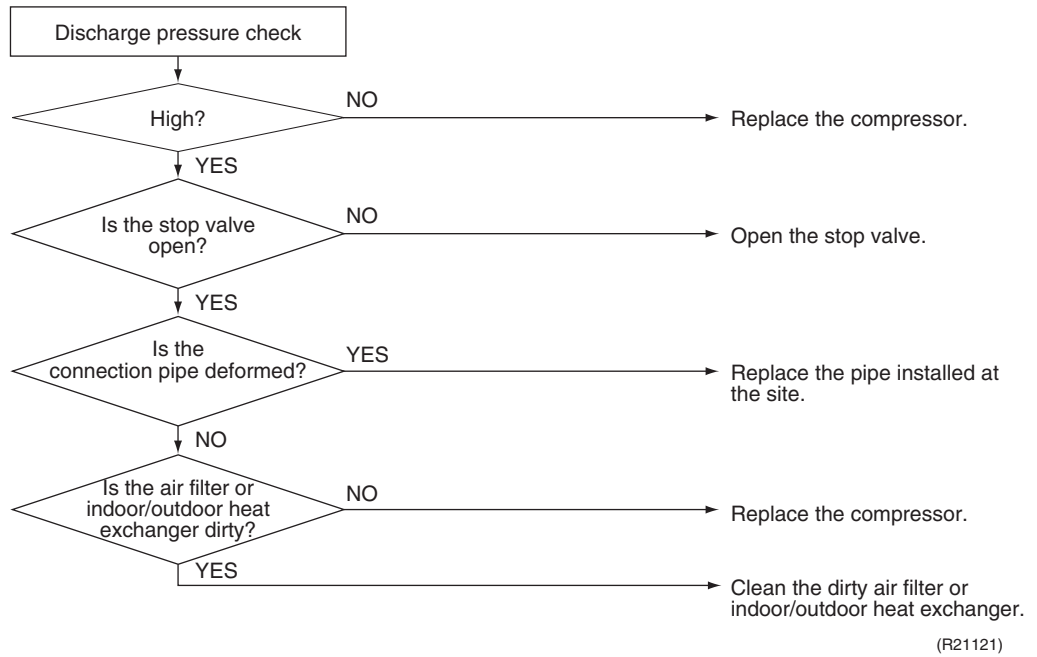

7.11 Outdoor Fan System Check

Check No.19

DC motor

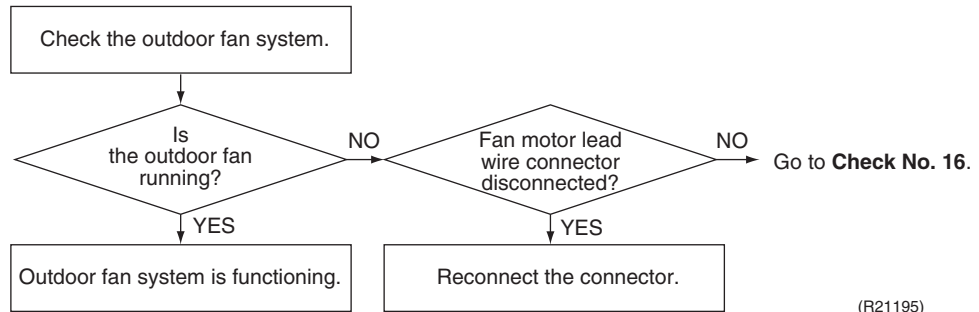

7.12 Main Circuit Short Check

Check No.20

Check to make sure that the voltage between (+) and (-) of the diode bridge (DB1) is about 0 V before checking

- Measure the resistance between the pins of the DB1 referring to the table below.
- If the resistance is ∞ or less than 1 k Ω , short circuit occurs on the main circuit.

| | | | | |
|---|---|----------|----------|----------|
| Positive terminal (+) of digital multimeter | ~ (2, 3) | + (4) | ~ (2, 3) | – (1) |
| Negative terminal (–) of digital multimeter | + (4) | ~ (2, 3) | – (1) | ~ (2, 3) |
| Resistance is OK. | several k Ω ~ several M Ω | | | |
| Resistance is NG. | 0 Ω or ∞ | | | |

■ 09 class

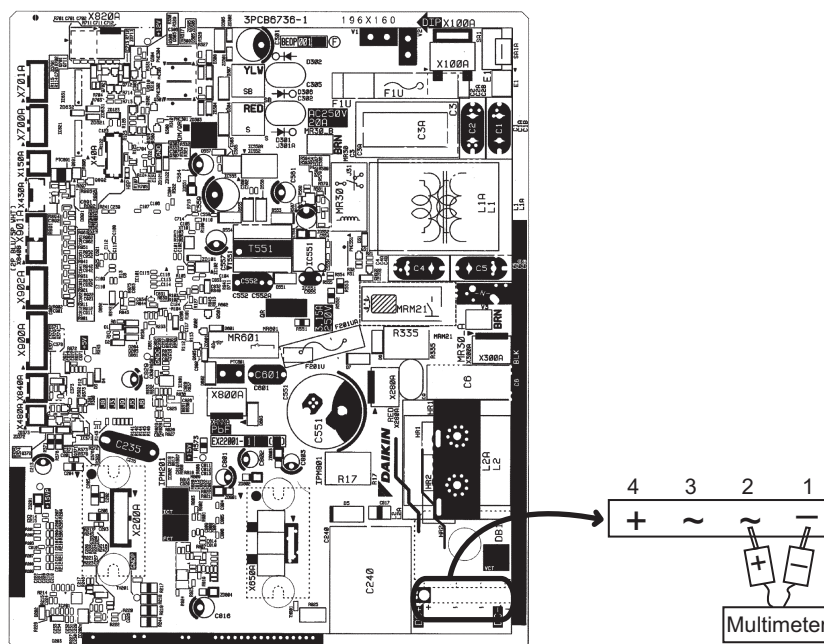

R6001098

■ 12 class

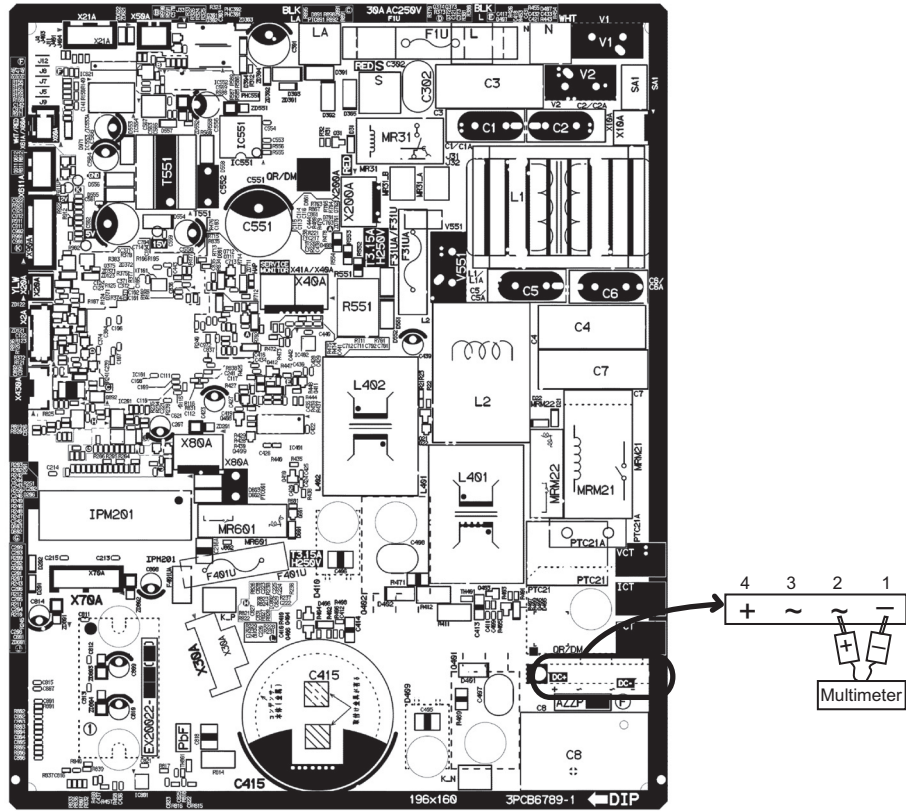

R6001208

■ 15/18/24 class

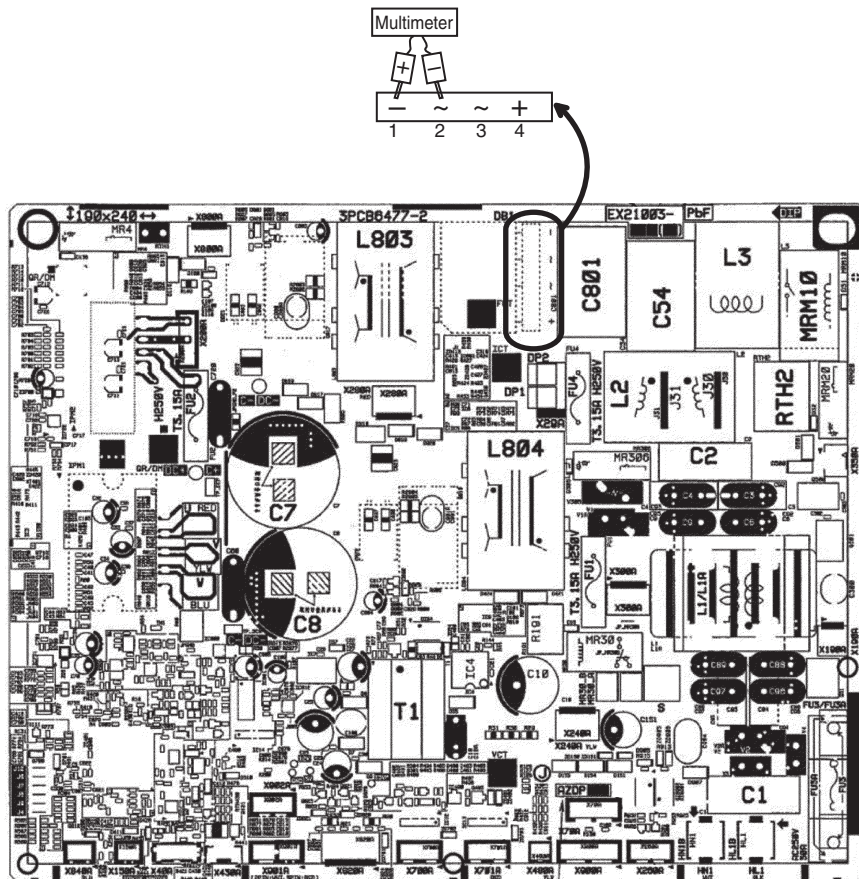

R6001213

7.13 Power Module Check

Check No.22

Check to make sure that the voltage between (+) and (-) of the power module is about 0 V before checking.

- Disconnect the compressor harness connector from the outdoor unit PCB. To disengage the connector, press the protrusion on the connector.
- Follow the procedure below to measure resistance between the terminals of the power module and the terminals of the compressor with a multimeter. Evaluate the measurement results referring to the following table.

| | | | | |
|---|-------------------------|------------------|------------------|------------------|
| Positive terminal (+) of digital multimeter | Power module (+) | UVW | Power module (-) | UVW |
| Negative terminal (-) of digital multimeter | UVW | Power module (+) | UVW | Power module (-) |
| Resistance is OK. | several kΩ ~ several MΩ | | | |
| Resistance is NG. | 0 Ω or ∞ | | | |

■ 09 class

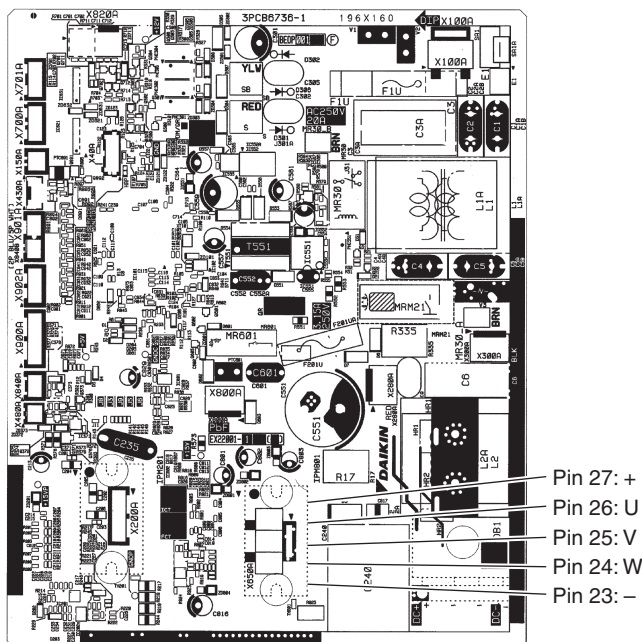

R6001240

■ 12 class

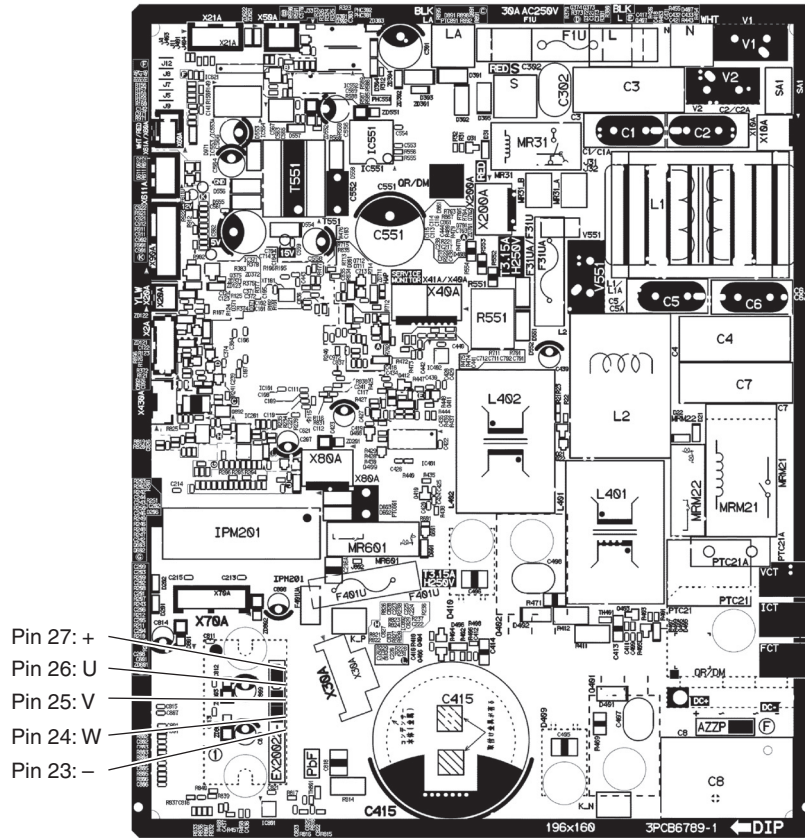

■ 15/18/24 class

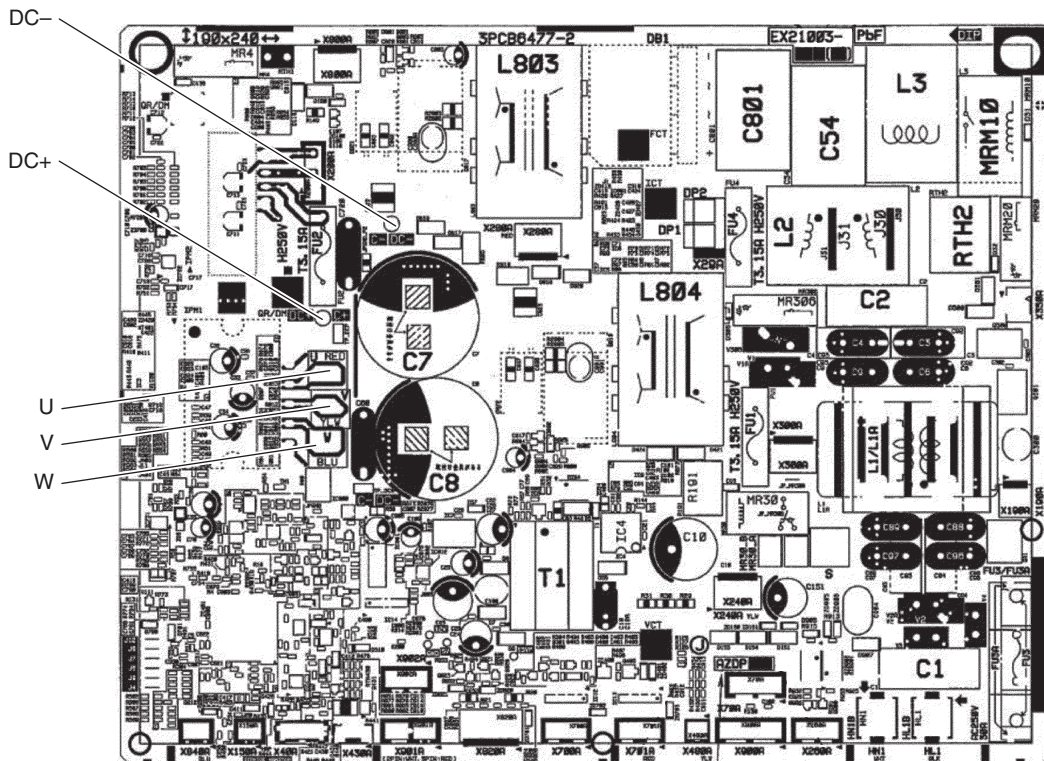

R6001214

Part 7

Trial Operation and Field Settings

| | |
|---|-----|
| 1. Pump Down Operation..... | 130 |
| 2. Forced Cooling Operation..... | 131 |
| 3. Trial Operation | 132 |
| 4. Field Settings | 134 |
| 4.1 When 2 Units are Installed in 1 Room..... | 134 |
| 4.2 Temperature Display Switch | 137 |
| 4.3 Facility Setting (cooling at low outdoor temperature) | 138 |
| 4.4 Warmer Airflow Setting..... | 139 |
| 4.5 Drain Pan Heater..... | 140 |
| 4.6 Service Mode of Wireless Remote Controller | 141 |
| 5. Silicone Grease on Power Transistor/Diode Bridge..... | 143 |

1. Pump Down Operation

Outline

In order to protect the environment, be sure to conduct pump down operation when relocating or disposing of the unit.

Details

1. Remove the valve caps from the liquid stop valve and the gas stop valve.
2. Carry out forced cooling operation.
3. After 5 to 10 minutes, close the liquid stop valve with a hexagonal wrench.
4. After 2 to 3 minutes, close the gas stop valve and stop the forced cooling operation.
5. Attach the valve cap once procedures are complete.

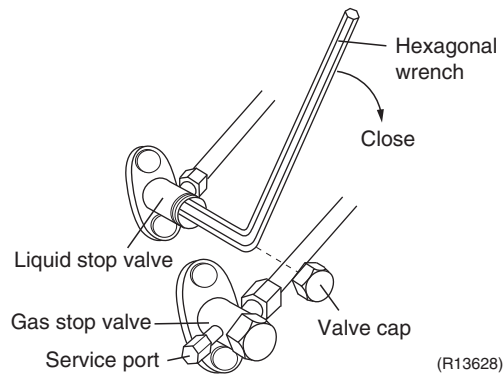

Reference

Refer to Forced Cooling Operation on page 131 for details.

2. Forced Cooling Operation

Outline

The forced cooling operation is allowed when both the following conditions are met.

1. The outdoor unit is not abnormal and not in the 3-minute standby mode.
2. The outdoor unit is not operating.

Protection functions have priority over all other functions during forced cooling operation.

Details

■ With indoor unit ON/OFF switch

Press indoor unit **ON/OFF** switch for at least 5 seconds. The operation will start.

Forced cooling operation will stop automatically after about 15 minutes.

To stop the operation, press indoor unit **ON/OFF** switch.

■ 09/12 class

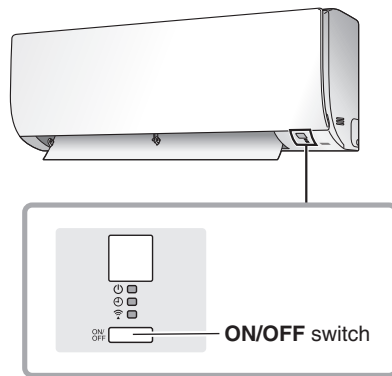

R4004127

■ 15/18/24 class

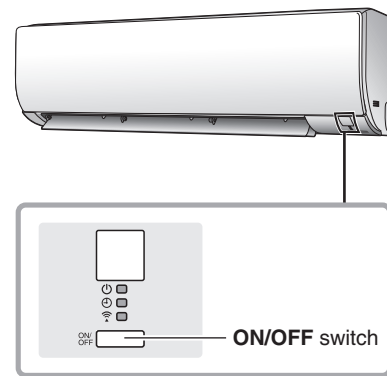

R4004128

3. Trial Operation

Outline

- Trial operation should be carried out in either cooling or heating operation.
 1. Measure the supply voltage and make sure that it is within the specified range.
 2. In cooling operation, select the lowest programmable temperature; in heating operation, select the highest programmable temperature.
 3. Carry out the trial operation in accordance with the operation manual to ensure that all functions and parts, such as louvers movement, are working properly.
 - For protection, the system disables restart operation for 3 minutes after the system has been turned off.
 4. After trial operation is complete, set the temperature to a normal level (26 ~ 28°C (78 ~ 82°F) in cooling, 20 ~ 24°C (68 ~ 75°F) in heating).

Procedure

When operating the air conditioner in COOL operation in winter, or HEAT operation in summer, set it to the trial operation mode using the following method.

■ ARC480 Series

1. Press the center of **TEMP** button and **OFF** button on the remote controller at the same time.
2. Select **T** (trial operation) with **Temp** \wedge , or \vee button.
3. Press **FAN** button to enter the trial operation mode.
4. Press **COOL** or **HEAT** button to start trial operation.
5. Trial operation terminates in about 30 minutes and switches into normal mode.
To quit trial operation, press **OFF** button.

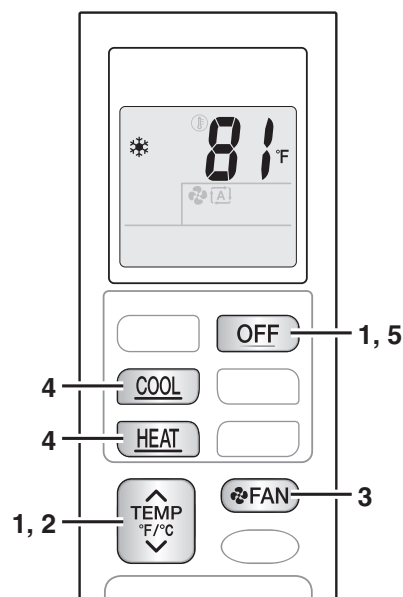

R7000277



Note(s)

- The air conditioner draws a small amount of power in its standby mode. If the system is not to be used for some time after installation, shut off the circuit breaker to eliminate unnecessary power consumption.
- If the circuit breaker trips to shut off the power to the air conditioner, the system will restore the original operation mode when the circuit breaker is opened again.

Test Items

| Test items | Symptoms |
|--|--|
| Indoor and outdoor units are installed securely. | Fall, vibration, noise |
| No refrigerant gas leaks. | Incomplete cooling/heating function |
| Refrigerant gas and liquid pipes and indoor drain hose extension are thermally insulated. | Water leakage |
| Draining line is properly installed. | Water leakage |
| System is properly grounded. | Electrical leakage |
| Only specified wires are used for all wiring, and all wires are connected correctly. | No operation or burn damage |
| Indoor or outdoor unit's air inlet or air outlet are unobstructed. | Incomplete cooling/heating function |
| Stop valves are opened. | Incomplete cooling/heating function |
| Indoor unit properly receives remote control commands. | No operation |
| Explain to the user that when using a smartphone for operation, it is necessary to prepare a repeater, or similar device, if the signal from the wireless LAN router is weak near the air conditioner. | Air conditioner not responding to smartphone |

4. Field Settings

4.1 When 2 Units are Installed in 1 Room

Outline

When 2 indoor units are installed in one room, the 2 wireless remote controllers can be set for different addresses. Change the address setting of one of the 2 units.

Procedure

■ ARC480A83 Wireless Remote Controller

1. Remove the battery cover of the remote controller.
2. Cut the address jumper.
3. Press the center of **TEMP** button and **OFF** button on the remote controller at the same time.
4. Press **TEMP ▲** or **TEMP ▼** button to select **A** (address setting).
5. Press **FAN** button to enter the address setting mode.
Then, the indoor unit OPERATION lamp will blink for about 1 minute.
6. Press the indoor unit **ON/OFF** switch while the OPERATION lamp is blinking.
7. Press **FAN** button on the remote controller for 5 seconds to return to the previous display.

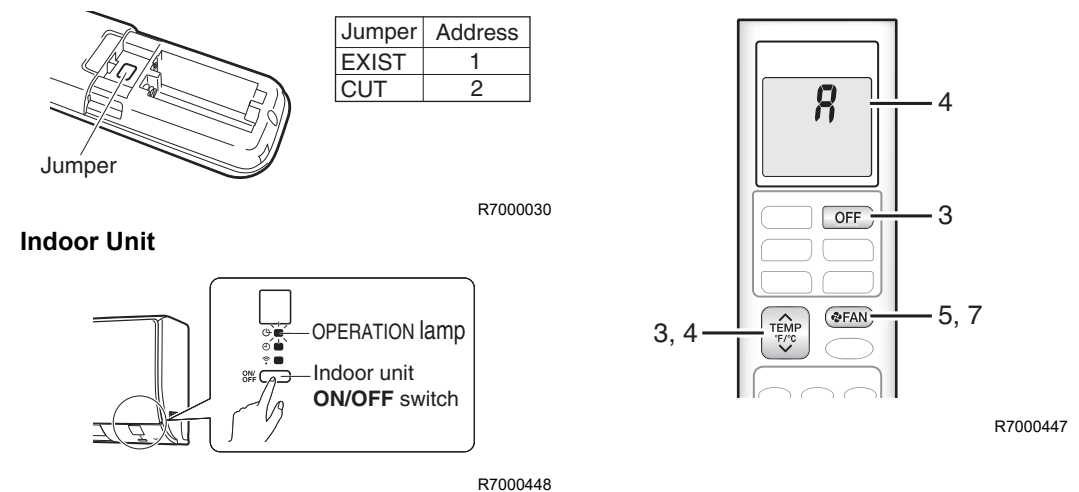

Note(s)

If setting could not be carried out completely while the OPERATION lamp was blinking, carry out the setting process once again from the beginning.



Caution

Replace the remote controller if you cut a jumper unintentionally.

Jumpers are necessary for electronic circuit. Improper operation may occur if you cut any of them.

Procedure

■ BRC073A6 Wired Remote Controller

6-1 Press and hold the Cancel button for 4 seconds or longer. **6-1** The Service Settings menu is displayed.

<Basic screen>

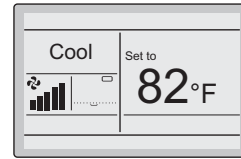

6-2 Select **Field Settings** and press the Menu/Enter button. **6-2**

<Service Settings>

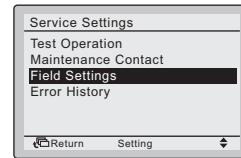

<Field settings>

6-3 Highlight the "Mode No.", and select the desired "Mode No." by using the ▲▼ (Up/Down) buttons. **6-3**

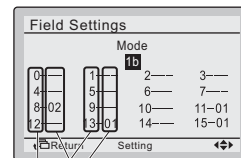

SECOND CODE NO.
FIRST CODE (SW) NO.

- The current settings are displayed.
- CODE NO. " -- " means that there is no function available.

6-4 Highlight the SECOND CODE of the FIRST CODE NO. to be changed and select the desired SECOND CODE NO. by using the ▲▼ (Up/Down) buttons. Multiple identical mode number settings are available.

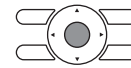

Press the Menu/Enter button.



6-5 Press the Menu/Enter button. The confirmation screen is displayed. **6-5**

6-6 Select **Yes** and press the Menu/Enter button. The settings are saved and the Field settings screen returns. **6-6**

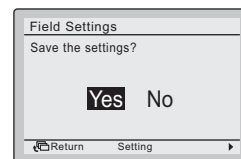

<Field Settings>

- 6-7** After all changes are completed, press the Cancel button twice.
- 6-8** The backlight goes out and "Checking the connection. Please stand by" is displayed during initialization. After the initialization, the Basic screen returns.

| Mode No. | First Code No. | Description of the setting | Second code No. | | | |
|----------|----------------|----------------------------|-----------------|-----------|-----------|----------------|
| | | | 01 | 02 | 03 | 04 |
| 1b | 8 | Daylight Saving Time | Disable | Enable* | — | — |
| | 11 | (Private use) | NA* | NA | — | — |
| | 13 | Basic screen display | Icon+Text* | Icon | — | — |
| | 15 | (Private use) | NA* | NA | — | — |
| 1c | 0 | (Private use) | NA | NA* | — | — |
| | 2 | (Private use) | NA | NA* | — | — |
| | 4 | (Private use) | NA | NA* | — | — |
| | 5 | (Private use) | NA* | — | — | — |
| | 6 | (Private use) | NA* | — | — | — |
| | 14 | (Private use) | NA* | NA | — | — |
| 1e | 1 | (Private use) | NA | NA* | — | — |
| | 2 | Setback function | Do not use | Heat only | Cool only | Cool and Heat* |
| | 5 | (Private use) | NA | NA* | — | — |
| | 6 | (Private use) | NA | NA* | — | — |
| | 8 | (Private use) | NA* | — | — | — |
| | 9 | (Private use) | NA | NA* | — | — |
| | a | (Private use) | NA* | — | — | — |

* Factory default setting

4.2 Temperature Display Switch

ARC480A83

- You can select Fahrenheit or Celsius for temperature display.
- Press **TEMP ▲** button and **ON TIMER** buttons simultaneously for 5 seconds to change the unit of temperature display.

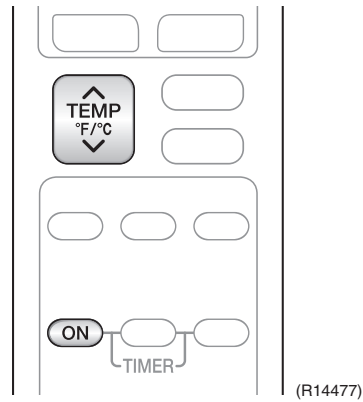

BRC073A6

You can select Fahrenheit or Celsius for temperature display.

- Display the Configuration menu.
- Press the ▲ or ▼ buttons to select "**Celsius / Fahrenheit**" and press the **Menu/Enter** button.

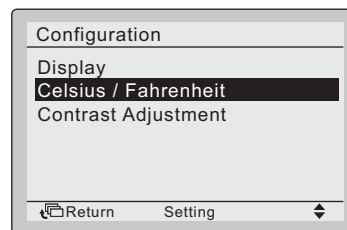

- Press the ▲ or ▼ buttons to select **Celsius** or **Fahrenheit**.
- Press the **Menu/Enter** button to confirm the settings and to return to the Basic Screen.

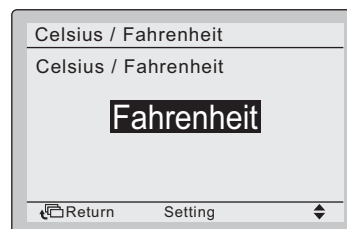

4.3 Facility Setting (cooling at low outdoor temperature)

Outline

This function is limited only for facilities (the target of air conditioning is equipment such as computers). Never use it in a residence or office (the space where there is a human).

Details

09/12 class

Cutting the Jumper 6 (J6) for RXT09, Jumper 7 (J7) for RXT12 on the circuit board will expand the operation range down to 14°F (−10°C). Installing an air direction adjustment grille (sold separately) will further extend the operation range to −4°F (−20°C). In these cases, the unit will stop operating if the outdoor temperature falls below −4°F (−20°C), restarting once the temperature rises above this level.

- (1) Remove the top plate of the outdoor unit. (4 screws)
- (2) Remove the front plate. (5 screws)
- (3) Cut the Jumper 6 (J6) for RXT09, Jumper 7 (J7) for RXT12 of the PCB inside.

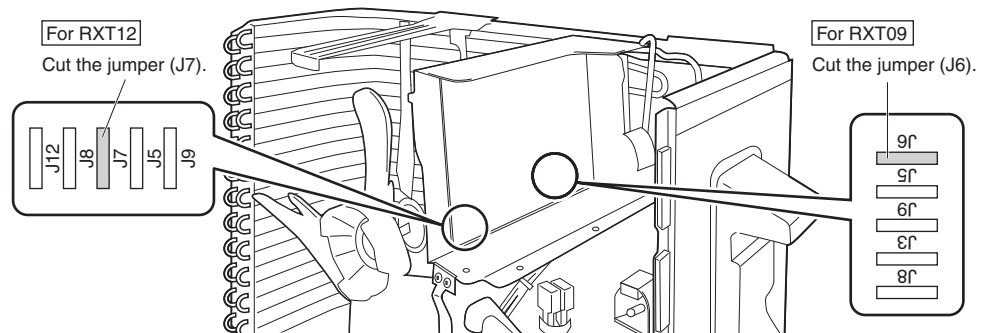

R7000455

15/18/24 class

Cutting jumper 7 (J7) on the PCB will extend the operation range to 14°F (−10°C). Installing an air direction adjustment grille (sold separately) will further extend the operation range to −4°F (−20°C). In these cases, the unit will stop operating if the outdoor temperature falls below −4°F (−20°C), restarting once the temperature rises above this level.

- (1) Remove the top plate of the outdoor unit. (6 screws)
- (2) Remove the front plate. (10 screws)
- (3) Remove the anti-drip cover.
- (4) Cut the jumper (J7) of the PCB inside.

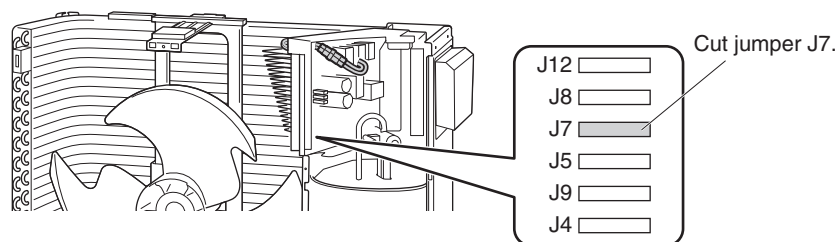

R7000456



Reference

For the location of the jumper, refer to pages 22, 24, 25.



Caution

- If the outdoor unit is installed where the heat exchanger of the unit is exposed to direct wind, provide a windbreak wall.
- Intermittent noises may be produced by the indoor unit due to the outdoor fan turning on and off when using facility settings.
- Do not place humidifiers or other items which might raise the humidity in rooms where facility settings are being used.
A humidifier might cause dew jumping from the indoor unit outlet vent.

- Activating the facility setting sets the indoor fan tap to the highest position. Notify the user about this.



Caution

Replace the PCB if you cut a jumper unintentionally.

Jumpers are necessary for electronic circuit. Improper operation may occur if you cut any of them.

4.4 Warmer Airflow Setting

Outline

The temperature of discharge airflow in heating operation can be adjusted warmer.

- The room temperature will be high when getting close to the set temperature.
- The discharge airflow does not become warmer in other than heating operation.

Procedure

Warmer airflow can be enabled/disabled from remote controller or outdoor unit.

From remote controller

Refer to page 141 for details of setting procedure.

Cut the jumper (J5) of the PCB inside.

■ 09/12 class

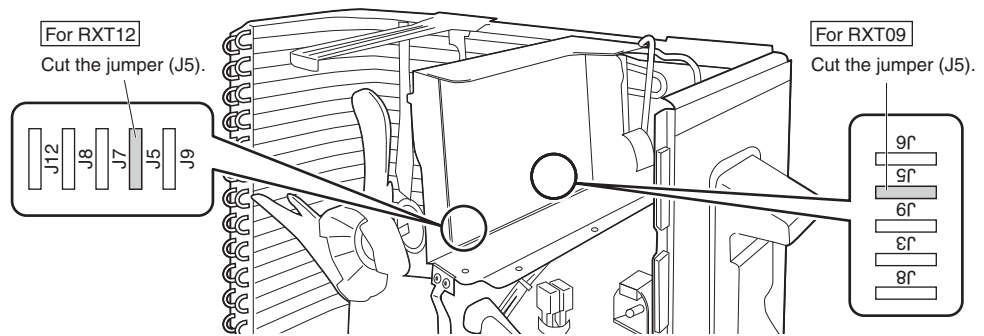

R7000457

■ 15/18/24 class

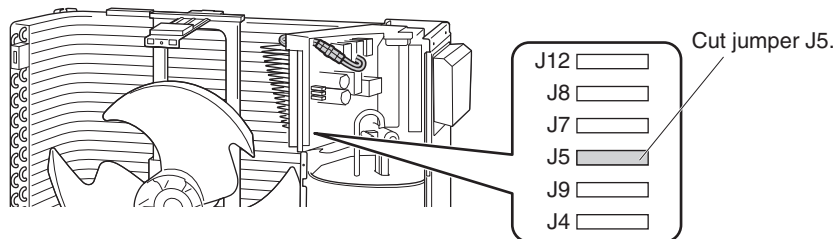

R7000458



Reference

For the location of the jumper, refer to page 22, 24, 25.



Note(s)

Warmer airflow can be enabled from either indoor or outdoor unit. Warmer airflow becomes available when either one of the RC or outdoor unit setting is enabled. For example, if the outdoor unit has the switch for warmer airflow, it can be set even when it is disabled on the indoor unit.

Also, for the wireless remote controller with field setting function, warmer airflow is enabled when set on indoor unit with the remote controller field setting, even when it is disabled on outdoor unit.

4.5 Drain Pan Heater

In high humidity areas or heavy snow areas, it is recommended to attach a drain pan heater to prevent ice build-up from the bottom frame.

1. Attach the drain pan heater in accordance with the installation manual included with the drain pan heater.
2. Cut the jumper (J9) of the PCB inside.

■ 09/12 class

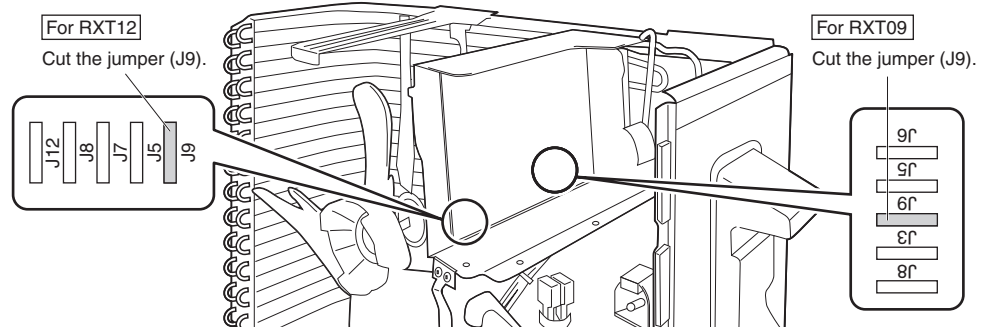

R7000459

■ 15/18/24 class

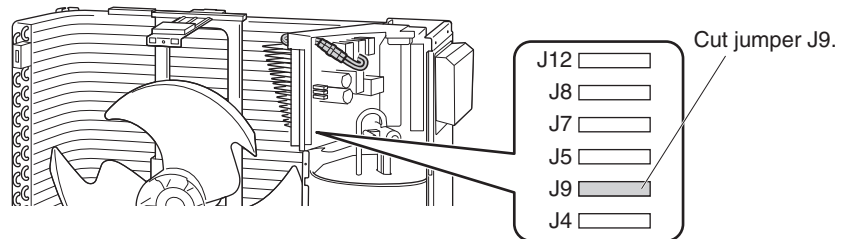

R7000460



Reference

For the location of the jumper, refer to page 22, 24, 25.

4.6 Service Mode of Wireless Remote Controller

The remote controller mode is hierarchized by special conditions and operation content. Refer below for the main hierarchy of the menu.

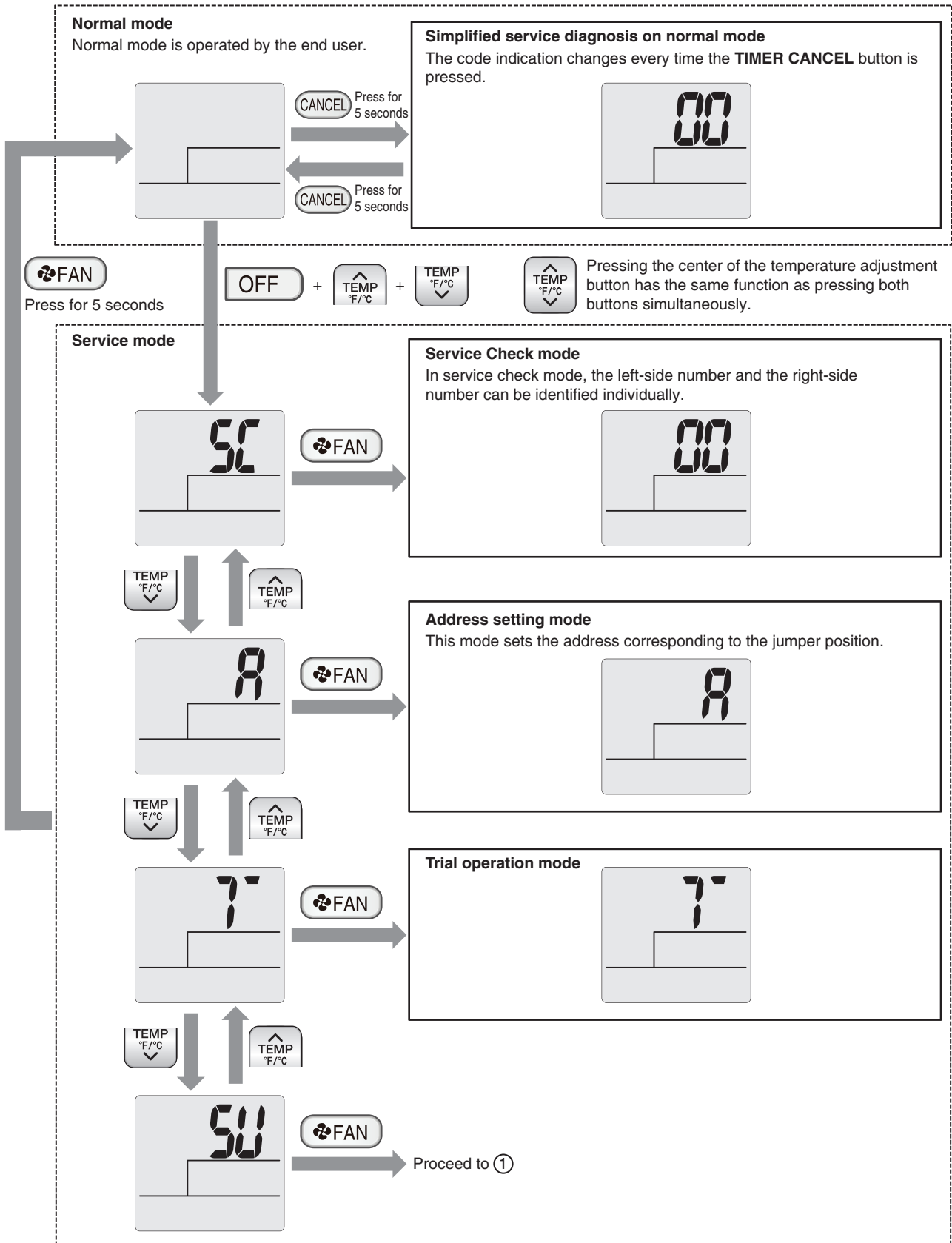

R5000463

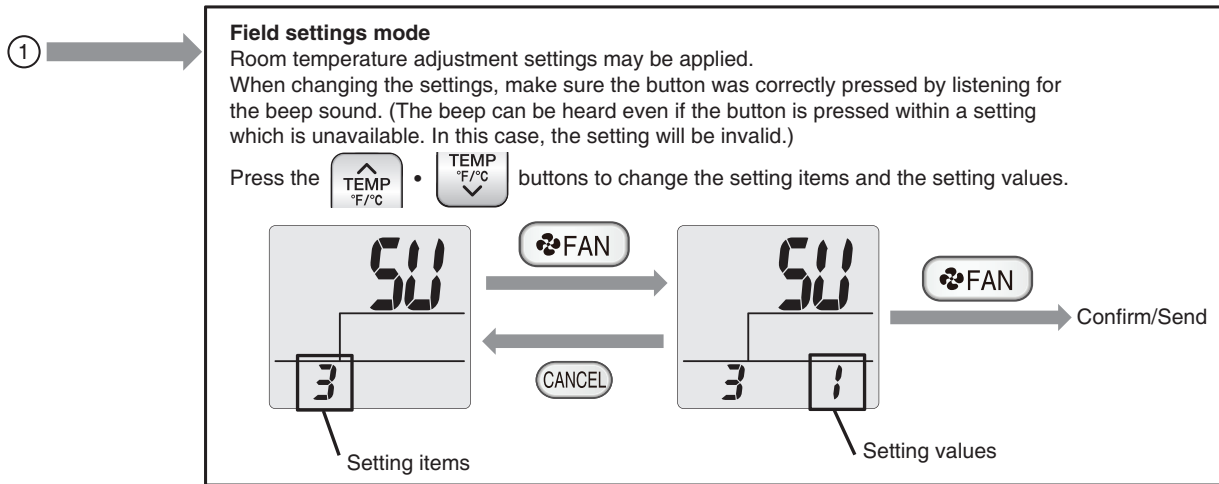

R5000462

Overview of Settings

| Setting items | Setting options | Factory Setting | Contents |
|---------------|--|-----------------|--|
| 3 | Suspend 0: OFF 1: ON | 1 | Activation/Deactivation of Standby electricity saving (suspend function) 0: Power will still be supplied to the outdoor unit PCB after the unit operation stopped. 1: Three minutes after the unit operation stops, the power supply to the outdoor unit PCB is shut off. (This function is only available on certain models.) |
| 4 | Dry keep 0: OFF 1: ON | 0 | Stops the airflow of indoor unit when the thermostat is OFF to prevent increase of room humidity. 0: When thermostat is OFF, the fan rotor will still be OPERATING, hence there is airflow. 1: When thermostat is OFF, the fan rotor will be STOPPED, hence there is no airflow. |
| 5 | Preheating control 0: OFF 1: ON | 1 | Activation/Deactivation of compressor preheating 0: Deactivation of compressor preheating 1: Activation of compressor preheating |
| 6 | Room temperature adjustment (cooling) 0: Low 2 (-2°C) 1: Low 1 (-1°C) 2: Standard (0°C) 3: High 1 (+1°C) 4: High 2 (+2°C) | 2 | Adjustment of indoor temperature thermistor in cooling operation. Used for adjustment of room temperature control. |
| 7 | Room temperature adjustment (heating) 0: Low 2 (-2°C) 1: Low 1 (-1°C) 2: Standard (0°C) 3: High 1 (+1°C) 4: High 2 (+2°C) | 2 | Adjustment of indoor temperature thermistor in heating operation. Used for adjustment of room temperature control. |
| 10 | Auto-restart 0: OFF 1: ON | 1 | This setting decides the operation of the unit when the power supply resumed after a power supply shutdown (i.e. power failure). 0: When the power supply resumes, the unit remains in stopped operation. 1: When the power supply resumes, the unit resumes the operation before the shutdown of power supply. |
| 12 | Warmer airflow setting 0: OFF 1: ON | 0 | This setting makes the discharge airflow temperature warmer. |



Note(s)

After replacing the indoor unit PCB, all the values are returned to the factory settings. Use the remote controller to change the settings again. When only the remote controller is replaced, the values stored in the PCB remain the same. There is no hassle to the end user.

5. Silicone Grease on Power Transistor/Diode Bridge

Outline

Apply the specified silicone grease to the heat generation part of a power transistor/diode bridge when you replace an outdoor unit PCB. The silicone grease encourages the heat dissipation of a power transistor/diode bridge.

Details

1. Wipe off the old silicone grease completely.
2. Apply the silicone grease evenly. See the illustrations below for examples of application.
3. Tighten the screws of the power transistor/diode bridge.
4. Make sure that the heat generation parts are firmly contacted to the radiation fin.

Note: Smoke emission may be caused by bad heat radiation when the silicone grease is not appropriately applied.

- OK: Evenly applied

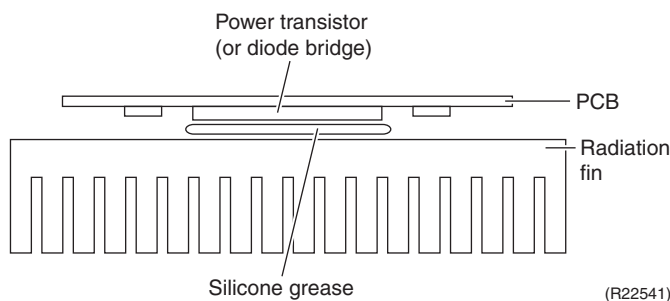

- NG: Not evenly applied

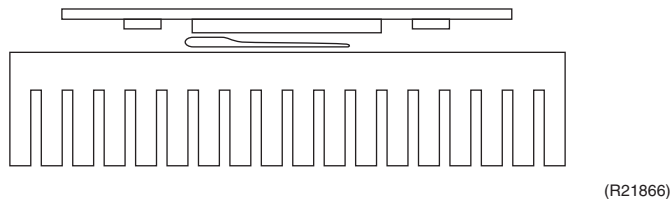

- NG: Foreign matter is stuck.

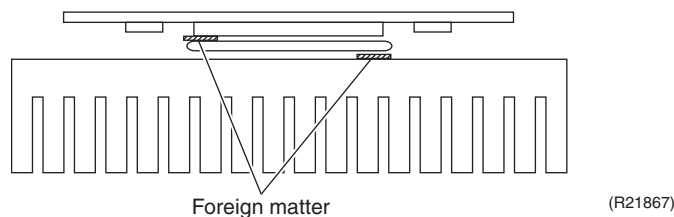

Part 8 Appendix

| | |
|-------------------------|-----|
| 1. Piping Diagrams..... | 145 |
| 1.1 Indoor Unit..... | 145 |
| 1.2 Outdoor Unit..... | 146 |
| 2. Wiring Diagrams..... | 149 |
| 2.1 Indoor Unit..... | 149 |
| 2.2 Outdoor Unit..... | 151 |
| 3. Operation Limit..... | 154 |

1. Piping Diagrams

1.1 Indoor Unit

FTXV09/12AVJU9

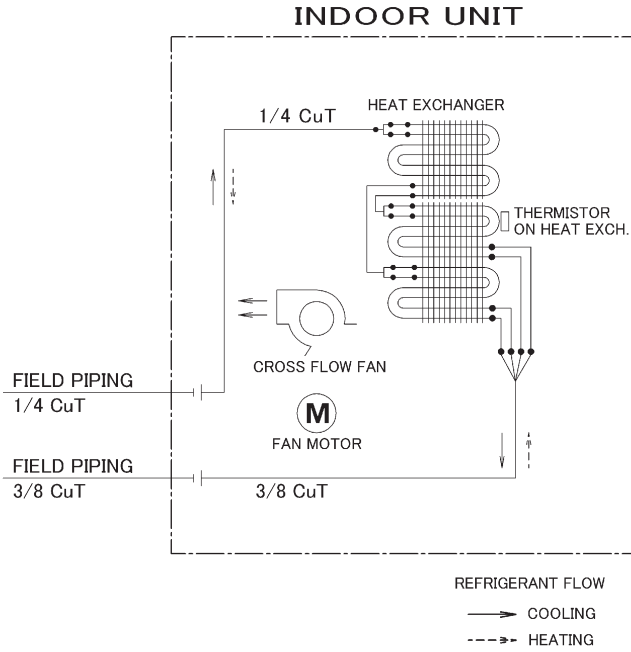

4D150950

FTXV15/18AVJU9

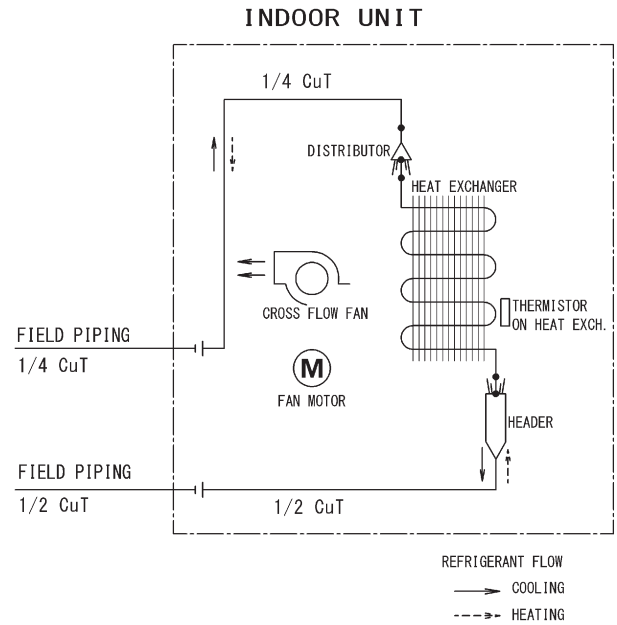

4D091769E

FTXV24AVJU9

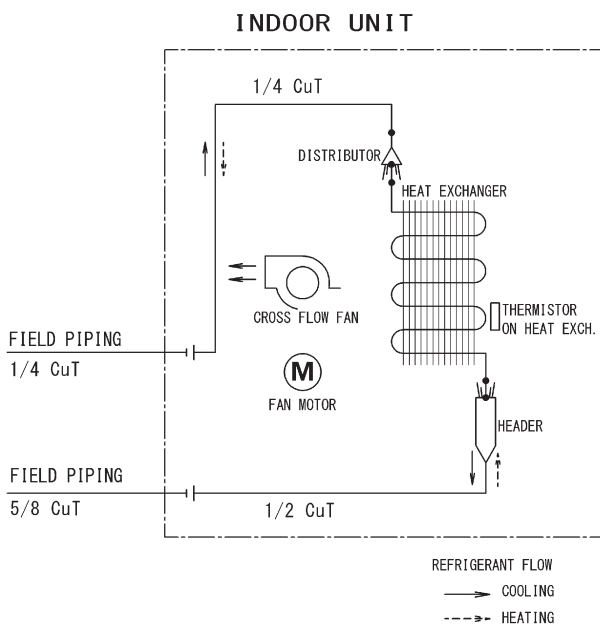

4D091768C

1.2 Outdoor Unit

RXT09AVJU9

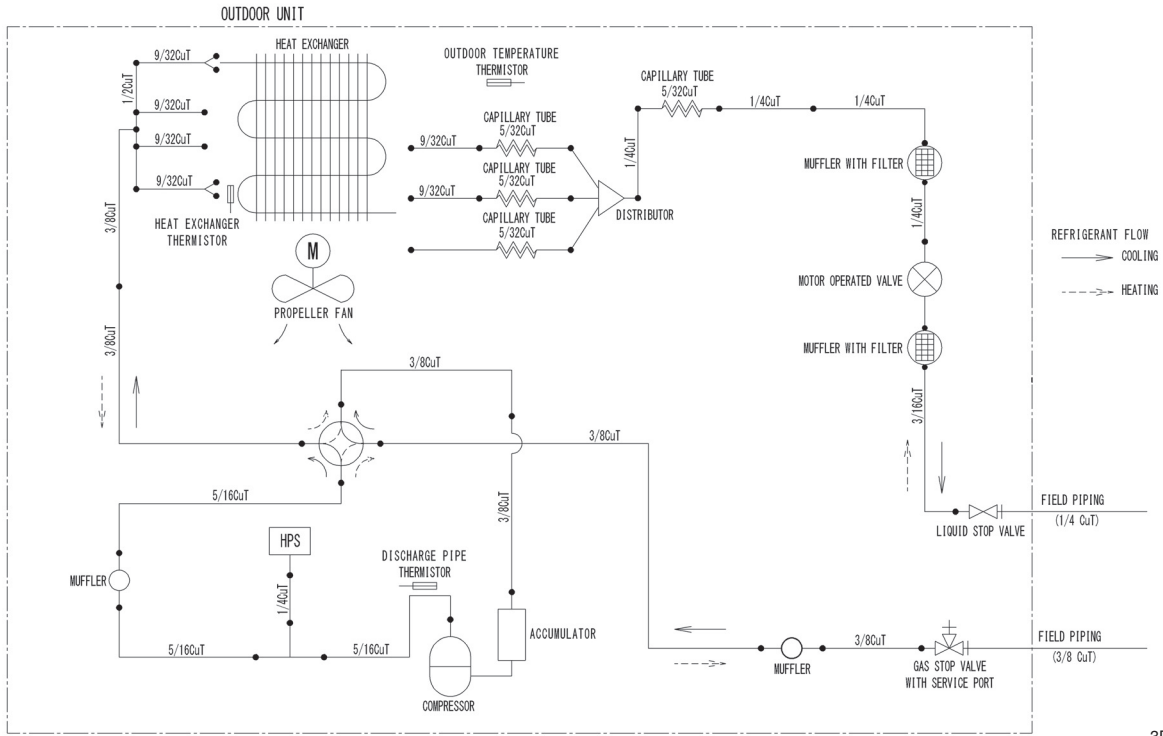

3D150194

RXT12AVJU9

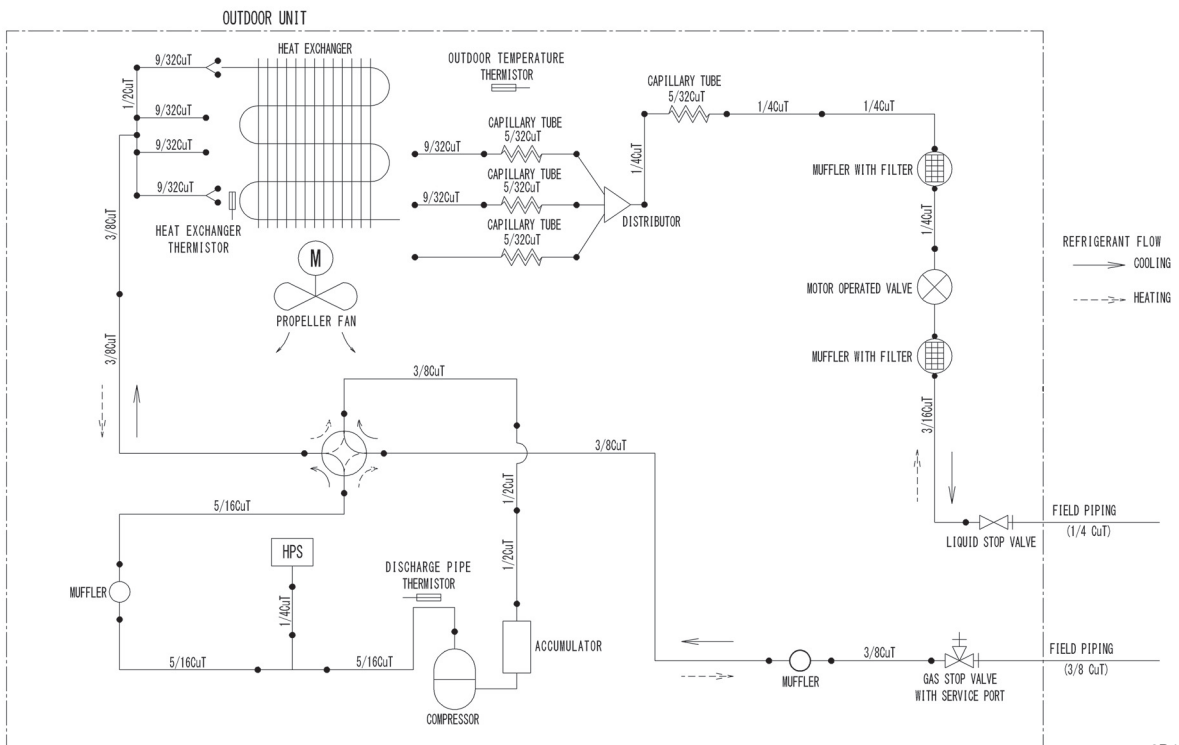

3D150947

RXT15AVJU9

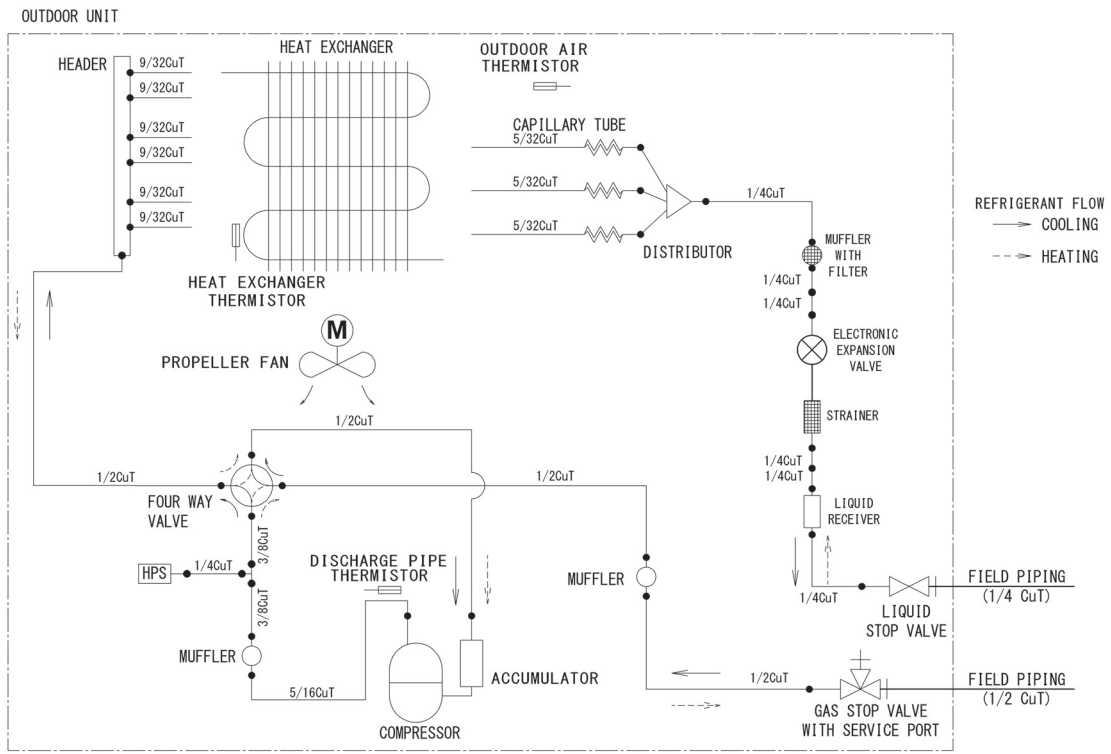

3D150094

RXT18AVJU9

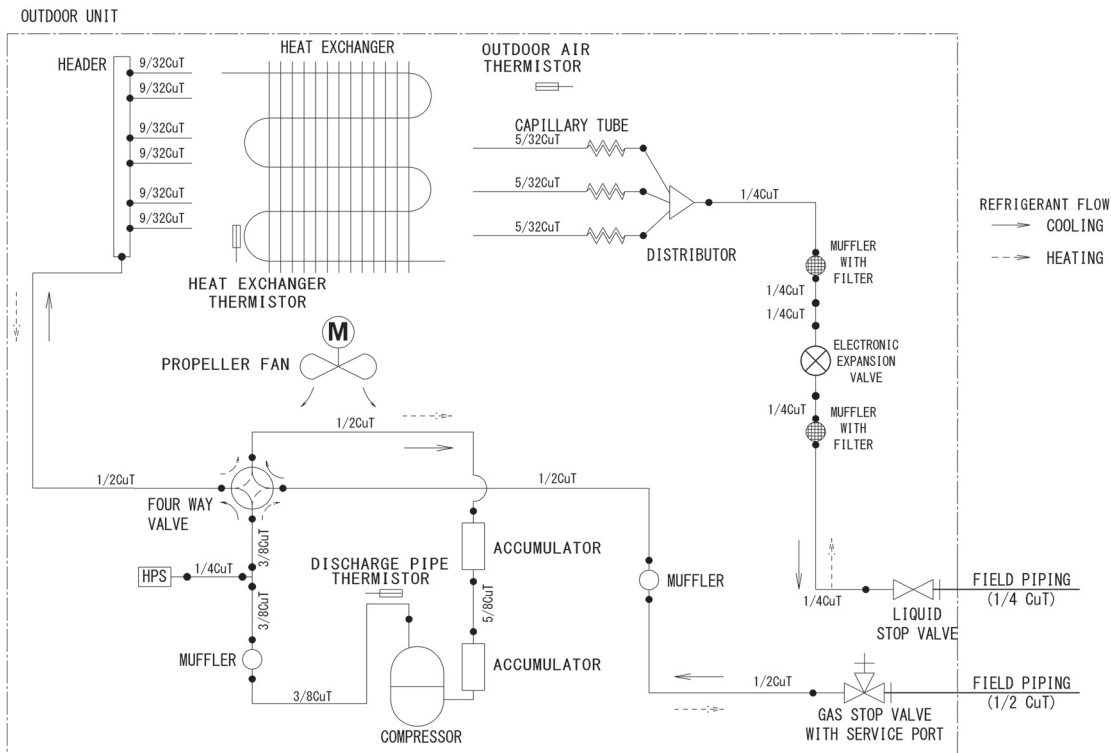

3D150095

RXT24AVJU9

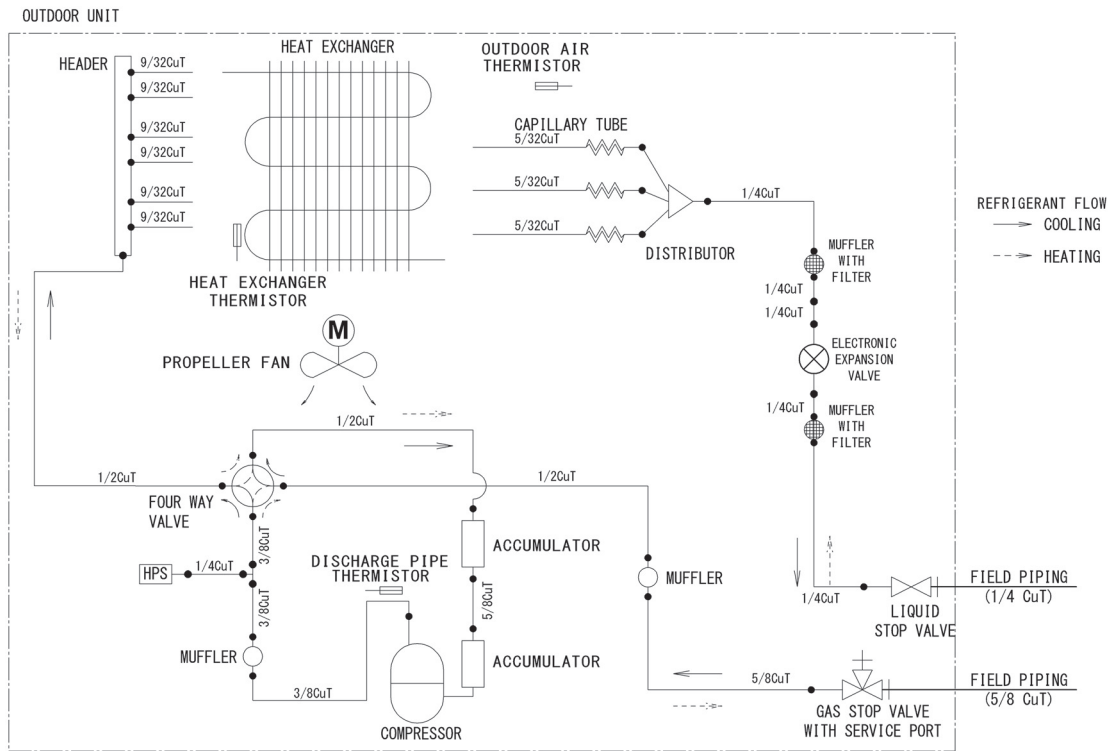

2. Wiring Diagrams

2.1 Indoor Unit

FTXV09/12AVJU9

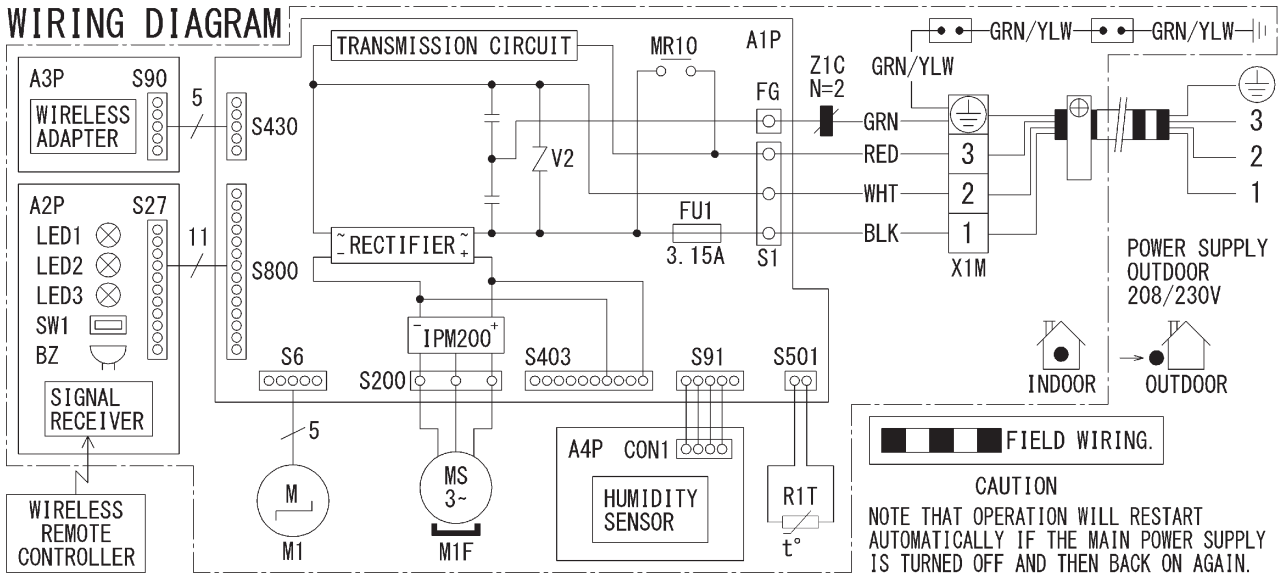

A1P~A4P :PRINTED CIRCUIT BOARD
 BZ :BUZZER
 FG :FRAME GROUND
 FU1 :FUSE
 LED1~LED3 :LIGHT-EMITTING DIODE
 M1F :FAN MOTOR

M1 :SWING MOTOR
 MR10 :RELAY
 R1T :THERMISTOR
 S1~S800, CON1 :CONNECTOR
 SW1 :OPERATION SWITCH

V2 :VARISTOR
 X1M :TERMINAL STRIP
 Z1C :FERRITE CORE
 ⊕ :PROTECTIVE EARTH (GROUND)

3D147521A



Note

A1P: Control PCB
 A2P: Display/signal receiver PCB
 A3P: Wireless LAN connection PCB
 A4P: Humidity sensor PCB
 Refer to page 20 for Printed Circuit Board Connector Wiring Diagram.

FTXV15/18/24AVJU9

WIRING DIAGRAM

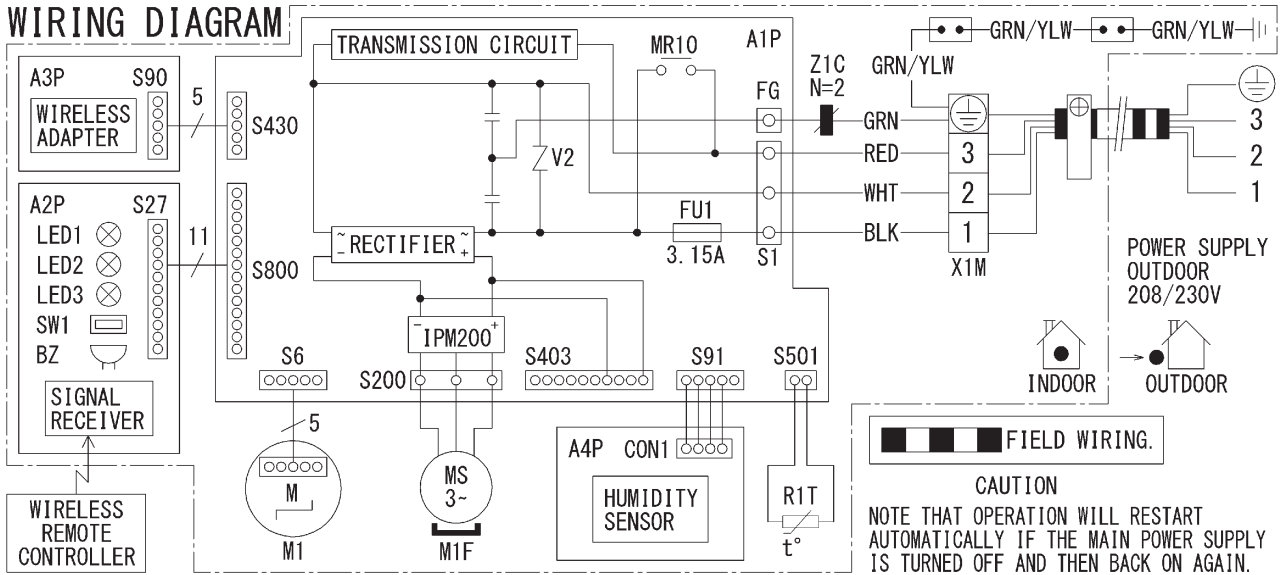

CAUTION
NOTE THAT OPERATION WILL RESTART AUTOMATICALLY IF THE MAIN POWER SUPPLY IS TURNED OFF AND THEN BACK ON AGAIN.

- | | | |
|----------------------------------|---------------------------|-------------------------------|
| A1P~A4P : PRINTED CIRCUIT BOARD | M1 : SWING MOTOR | V2 : VARISTOR |
| BZ : BUZZER | MR10 : RELAY | X1M : TERMINAL STRIP |
| FG : FRAME GROUND | R1T : THERMISTOR | Z1C : FERRITE CORE |
| FU1 : FUSE | S1~S800, CON1 : CONNECTOR | ⊕ : PROTECTIVE EARTH (GROUND) |
| LED1~LED3 : LIGHT-EMITTING DIODE | SW1 : OPERATION SWITCH | |
| M1F : FAN MOTOR | | |

3D147460B



Note

A1P: Control PCB
 A2P: Display/signal receiver PCB
 A3P: Wireless LAN connection PCB
 A4P: Humidity sensor PCB
 Refer to page 20 for Printed Circuit Board Connector Wiring Diagram.

2.2 Outdoor Unit

RXT09AVJU9

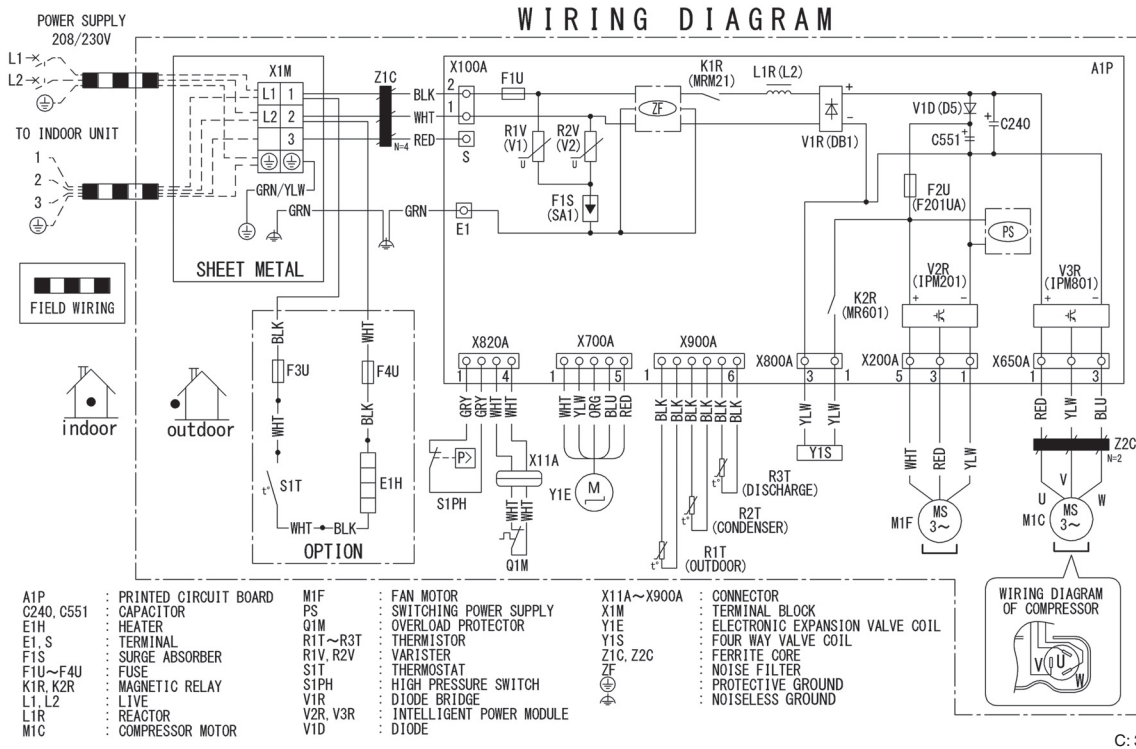

Note(s)

PCB1: Main PCB

Refer to page 22 for Printed Circuit Board Connector Wiring Diagram.

RXT12AVJU9

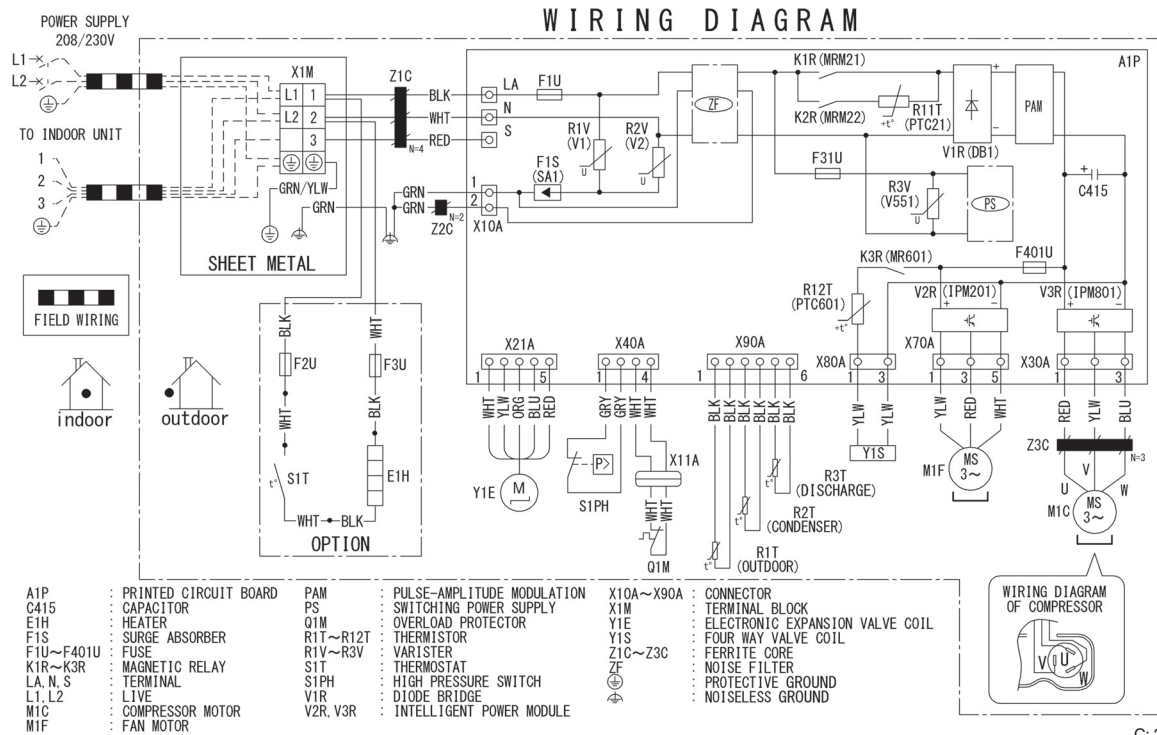

Note(s)

A1P: Main PCB
 Refer to page 24 for Printed Circuit Board Connector Wiring Diagram.

RXT15/18/24AVJU9

WIRING DIAGRAM

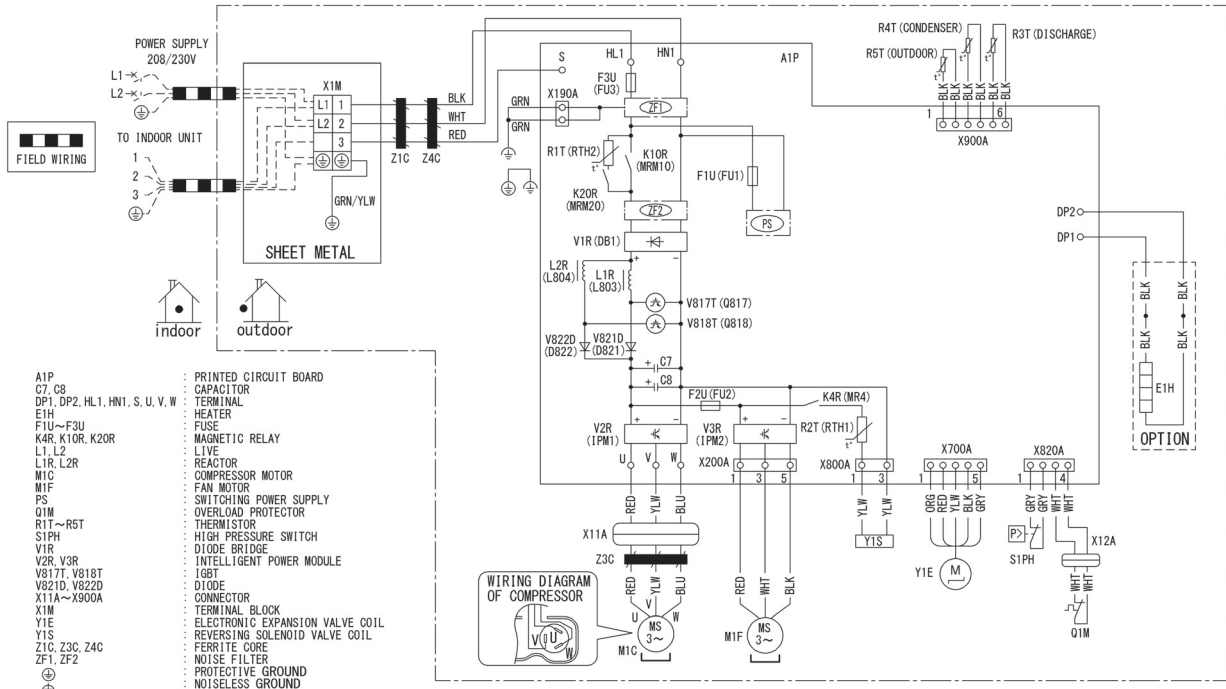

C: 3D149181



Note(s)

PCB: Main PCB
Refer to page 25 for Printed Circuit Board Connector Wiring Diagram.

3. Operation Limit

RXT09/12/15/18/24AVJU9

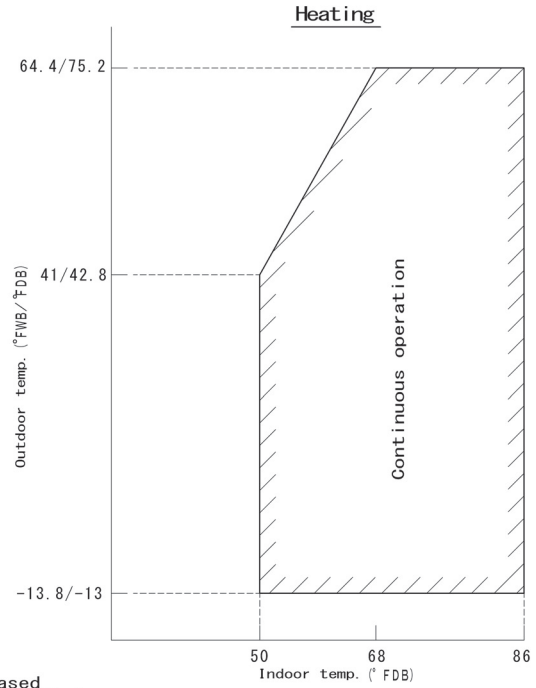
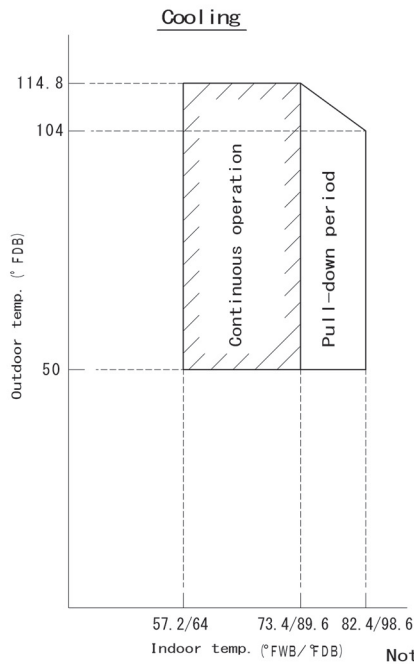

Notes:
The graphs are based on the following conditions.
• Equivalent piping length 25ft
• Level difference 0ft
• Air flow rate High

3D152633A

Warning

- Daikin products are manufactured for export to numerous countries throughout the world. Prior to purchase, please confirm with your local authorized importer, distributor and/or retailer whether this product conforms to the applicable standards, and is suitable for use, in the region where the product will be used. This statement does not purport to exclude, restrict or modify the application of any local legislation.
- Ask a qualified installer or contractor to install this product. Do not try to install the product yourself. Improper installation can result in water or refrigerant leakage, electrical shock, fire or explosion.
- Use only those parts and accessories supplied or specified by Daikin. Ask a qualified installer or contractor to install those parts and accessories. Use of unauthorized parts and accessories or improper installation of parts and accessories can result in water or refrigerant leakage, electrical shock, fire or explosion.
- Read the user's manual carefully before using this product. The user's manual provides important safety instructions and warnings. Be sure to follow these instructions and warnings.

If you have any inquiries, please contact your local importer, distributor and/or retailer.

Cautions on product corrosion

1. Air conditioners should not be installed in areas where corrosive gases, such as acid gas or alkaline gas, are produced.
2. If the outdoor unit is to be installed close to the sea shore, direct exposure to the sea breeze should be avoided. If you need to install the outdoor unit close to the sea shore, contact your local distributor.

© All rights reserved