

# Service Instructions

**GXV6S\*\*\*1\*A\* / GXV9SA\*\*1\*A\* / GZV6SA\*\*1\*A\* / GZV7SA\*\*1\*A\***  
**Inverter Outdoor Units,**  
**AHVE\*\* EEV Air Handlers & CAPEA\* / CHPEA\* EEV Cased Coils**  
**with R32 Refrigerant**



## WARNING

ONLY PERSONNEL THAT HAVE BEEN TRAINED TO INSTALL, ADJUST, SERVICE, MAINTENANCE OR REPAIR (HEREINAFTER, "SERVICE") THE EQUIPMENT SPECIFIED IN THIS MANUAL SHOULD SERVICE THE EQUIPMENT.  
THIS EQUIPMENT IS NOT INTENDED FOR USE BY PERSONS (INCLUDING CHILDREN) WITH REDUCED PHYSICAL, SENSORY OR MENTAL CAPABILITIES, OR LACK OF EXPERIENCE AND KNOWLEDGE, UNLESS THEY HAVE BEEN GIVEN SUPERVISION OR INSTRUCTION CONCERNING USE OF THE APPLIANCE BY A PERSON RESPONSIBLE FOR THEIR SAFETY.  
CHILDREN SHOULD BE SUPERVISED TO ENSURE THAT THEY DO NOT PLAY WITH THE EQUIPMENT.  
THE MANUFACTURER WILL NOT BE RESPONSIBLE FOR ANY INJURY OR PROPERTY DAMAGE ARISING FROM IMPROPER SUPERVISION, SERVICE OR SERVICE PROCEDURES. IF YOU SERVICE THIS UNIT, YOU ASSUME RESPONSIBILITY FOR ANY INJURY OR PROPERTY DAMAGE WHICH MAY RESULT. IN ADDITION, IN JURISDICTIONS THAT REQUIRE ONE OR MORE LICENSES TO SERVICE THE EQUIPMENT SPECIFIED IN THIS MANUAL, ONLY LICENSED PERSONNEL SHOULD SERVICE THE EQUIPMENT. IMPROPER SUPERVISION, INSTALLATION, ADJUSTMENT, SERVICING, MAINTENANCE OR REPAIR OF THE EQUIPMENT SPECIFIED IN THIS MANUAL, OR ATTEMPTING TO INSTALL, ADJUST, SERVICE OR REPAIR THE EQUIPMENT SPECIFIED IN THIS MANUAL WITHOUT PROPER SUPERVISION OR TRAINING MAY RESULT IN PRODUCT DAMAGE, PROPERTY DAMAGE, PERSONAL INJURY OR DEATH.

## WARNING

DO NOT BYPASS SAFETY DEVICES

# IMPORTANT INFORMATION

IMPORTANT INFORMATION .....	2 - 4
TESTING CAPACITOR DC VOLTAGE .....	5 - 6
SYSTEM OPERATION .....	7 - 11
SERVICING.....	12 - 34
FAULT RECALL (EEV INDOOR UNITS) .....	24
2-DIGIT 7 SEGMENT DISPLAYS (EEV INDOOR UNITS).....	25 - 26
SETTING THE MODE DISPLAY (EEV INDOOR UNITS) .....	27 - 28
INDOOR UNIT ERROR CODES (EEV INDOOR UNITS) .....	29 - 30
EMERGENCY MODE FOR EEV APPLICABLE INDOOR UNIT .....	31 - 34
SETTING THE MODE DISPLAY .....	35 - 40
7-SEGMENT DISPLAY .....	41 - 43
TROUBLESHOOTING - OUTDOOR UNIT .....	44 - 58
TROUBLESHOOTING - INDOOR UNIT .....	59 - 68
TROUBLESHOOTING .....	69 - 70
THERMISTOR RESISTANCE & TEMPERATURE CHARACTERISTICS.....	71
PRESSURE VS TEMPERATURE CHART.....	72
LIQUID LINE TEMPERATURE CHART .....	73
WIRING DIAGRAMS .....	74 - 82
REMOVAL & REASSEMBLY PROCEDURE.....	83 - 129
1.5 - 3.0 ton models and 2.0 ton Enhanced Capacity/ High Efficiency models.....	83 - 106
3.5 - 5.0 ton models and 3.0 - 4.0 ton Enhanced Capacity/ High Efficiency models.....	107 - 129
D-CHECKER ADDENDUM.....	130 - 135

## NOTICE

THIS MANUAL MAINLY DESCRIBES THE SERVICE CONTENTS OF OUTDOOR UNIT, EEV AIR HANDLER AND EEV CASED COIL. FOR INFORMATION ON GAS FURNACE AND MODULAR BLOWER, PLEASE REFER TO A SERVICE MANUAL OF EACH MODEL.

## IMPORTANT NOTICES FOR CONSUMERS AND SERVICERS

### RECOGNIZE SAFETY SYMBOLS, WORDS AND LABELS

#### WARNING

#### HIGH VOLTAGE !

DISCONNECT ALL POWER BEFORE SERVICING.  
MULTIPLE POWER SOURCES MAY BE PRESENT. FAILURE TO DO SO MAY CAUSE PROPERTY DAMAGE, PERSONAL INJURY OR DEATH.



#### WARNING

DO NOT CONNECT TO OR USE ANY DEVICE THAT IS NOT DESIGN CERTIFIED BY THE MANUFACTURER FOR USE WITH THIS UNIT. SERIOUS PROPERTY DAMAGE, PERSONAL INJURY, REDUCED UNIT PERFORMANCE AND/OR HAZARDOUS CONDITIONS MAY RESULT FROM THE USE OF SUCH NON-APPROVED DEVICES.

#### WARNING

TO PREVENT THE RISK OF PROPERTY DAMAGE, PERSONAL INJURY, OR DEATH, DO NOT STORE COMBUSTIBLE MATERIALS OR USE GASOLINE OR OTHER FLAMMABLE LIQUIDS OR VAPORS IN THE VICINITY OF THIS APPLIANCE.

Pride and workmanship go into every product to provide our customers with quality products. It is possible, however, that during its lifetime a product may require service. Products should be serviced only by a qualified service technician who is familiar with the safety procedures required in the repair and who is equipped with the proper tools, parts, testing instruments and the appropriate service manual. **REVIEW ALL SERVICE INFORMATION IN THE APPROPRIATE SERVICE MANUAL BEFORE BEGINNING REPAIRS.**

*To locate an authorized servicer, please consult your telephone book or the dealer from whom you purchased this product. For further assistance, please contact:*

#### CONSUMER INFORMATION LINE - DAIKIN BRAND PRODUCTS

**TOLL FREE 1-855-770-5678** (U.S. only)

email us at: [customerservice@daikincomfort.com](mailto:customerservice@daikincomfort.com)

fax us at: **(713) 856-1821**

*(Not a technical assistance line for dealers.)*

Outside the U.S., call 1-713-861-2500.  
*(Not a technical assistance line for dealers.)*  
our telephone company will bill you for the call.

#### SAFE REFRIGERANT HANDLING

While these items will not cover every conceivable situation, they should serve as a useful guide.

#### WARNING

REFRIGERANTS ARE HEAVIER THAN AIR. THEY CAN "PUSH OUT" THE OXYGEN IN YOUR LUNGS OR IN ANY ENCLOSED SPACE. TO AVOID POSSIBLE DIFFICULTY IN BREATHING OR DEATH:

- NEVER PURGE REFRIGERANT INTO AN ENCLOSED ROOM OR SPACE. BY LAW, ALL REFRIGERANTS MUST BE RECLAIMED.
- IF AN INDOOR LEAK IS SUSPECTED, THOROUGHLY VENTILATE THE AREA BEFORE BEGINNING WORK.
- LIQUID REFRIGERANT CAN BE VERY COLD. TO AVOID POSSIBLE FROST BITE OR BLINDNESS, AVOID CONTACT AND WEAR GLOVES AND GOGGLES. IF LIQUID REFRIGERANT DOES CONTACT YOUR SKIN OR EYES, SEEK MEDICAL HELP IMMEDIATELY.
- ALWAYS FOLLOW EPA REGULATIONS. NEVER BURN REFRIGERANT, AS POISONOUS GAS WILL BE PRODUCED.

# IMPORTANT INFORMATION

## WARNING

THE UNITED STATES ENVIRONMENTAL PROTECTION AGENCY ("EPA") HAS ISSUED VARIOUS REGULATIONS REGARDING THE INTRODUCTION AND DISPOSAL OF REFRIGERANTS INTRODUCED INTO THIS UNIT. FAILURE TO FOLLOW THESE REGULATIONS MAY HARM THE ENVIRONMENT AND CAN LEAD TO THE IMPOSITION OF SUBSTANTIAL FINES. THESE REGULATIONS MAY VARY BY JURISDICTION. SHOULD QUESTIONS ARISE, CONTACT YOUR LOCAL EPA OFFICE.

## WARNING

TO AVOID POSSIBLE EXPLOSION:

- NEVER APPLY FLAME OR STEAM TO A REFRIGERANT CYLINDER. IF YOU MUST HEAT A CYLINDER FOR FASTER CHARGING, PARTIALLY IMMERSE IT IN WARM WATER.
- NEVER FILL A CYLINDER MORE THAN 80% FULL OF LIQUID REFRIGERANT.
- NEVER ADD ANYTHING OTHER THAN R32 TO A RETURNABLE R32 CYLINDER. THE SERVICE EQUIPMENT USED MUST BE LISTED OR CERTIFIED FOR THE TYPE OF REFRIGERANT USE.
- STORE CYLINDERS IN A COOL, DRY PLACE. NEVER USE A CYLINDER AS A PLATFORM OR A ROLLER.

## WARNING

TO AVOID POSSIBLE EXPLOSION:

- USE ONLY RETURNABLE (NOT DISPOSABLE) SERVICE CYLINDERS WHEN REMOVING REFRIGERANT FROM A SYSTEM.
- ENSURE THE CYLINDER IS FREE OF DAMAGE WHICH COULD LEAD TO A LEAK OR EXPLOSION.
- ENSURE THE HYDROSTATIC TEST DATE DOES NOT EXCEED 5 YEARS.
- ENSURE THE PRESSURE RATING MEETS OR EXCEEDS 400 PSIG.

WHEN IN DOUBT, DO NOT USE THE CYLINDER.

## WARNING

TO AVOID POSSIBLE INJURY, EXPLOSION OR DEATH, PRACTICE SAFE HANDLING OF REFRIGERANTS.

## CAUTION

THE COMPRESSOR PVE OIL FOR R32 UNITS IS EXTREMELY SUSCEPTIBLE TO MOISTURE ABSORPTION AND COULD CAUSE COMPRESSOR FAILURE. DO NOT LEAVE SYSTEM OPEN TO ATMOSPHERE ANY LONGER THAN NECESSARY FOR INSTALLATION.

## NOTICE

THE ENTIRE SYSTEM (COMBINATION OF INDOOR AND OUTDOOR SECTIONS) MUST BE MANUFACTURER APPROVED AND AIR-CONDITIONING, HEATING, AND REFRIGERATION INSTITUTE (AHRI) LISTED.

NOTE: INSTALLATION OF UNMATCHED SYSTEMS IS NOT PERMITTED. DAMAGE OR REPAIRS DUE TO INSTALLATION OF UNMATCHED SYSTEMS IS NOT COVERED UNDER THE WARRANTY.

## NOTICE

APPROVED COMMUNICATING THERMOSTATS ARE GOODMAN GTST CONNECTED THERMOSTAT (HEREINAFTER REFERRED TO AS "THERMOSTAT")

## WARNING

SYSTEM CONTAMINANTS, IMPROPER SERVICE PROCEDURE AND/OR PHYSICAL ABUSE AFFECTING HERMETIC COMPRESSOR ELECTRICAL TERMINALS MAY CAUSE DANGEROUS SYSTEM VENTING.

## ELECTROSTATIC DISCHARGE (ESD) PRECAUTIONS

**NOTE:** Discharge body's static electricity before touching unit. Electrostatics can adversely affect electrical components.

Use the following precautions during units installation and servicing to protect the integrated control module from damage. By putting the units, the control, and the person at the same electrostatic potential, these steps will help avoid exposing the integrated control module to electrostatic discharge. This procedure is applicable to both installed and uninstalled (ungrounded) units.

1. Disconnect all power to the units. Do not touch the integrated control module or any wire connected to the control prior to discharging your body's electrostatic charge to ground.
2. Firmly touch a clean, unpainted, metal surface of the units near the control. Any tools held in a person's hand during grounding will be discharged.
3. Service integrated control module or connecting wiring following the discharge process in step 2. Use caution not to recharge your body with static electricity; (i.e., do not move or shuffle your feet, do not touch ungrounded objects, etc.). If you come in contact with an ungrounded object, repeat step 2 before touching control or wires.
4. Discharge your body to ground before removing a new integrated control module from its container. Follow steps 1 through 3 if installing the integrated control module on the units. Return any old or new integrated control modules to their containers before touching any ungrounded object.

# IMPORTANT INFORMATION

**NOTICE:** When the outdoor unit is connected to main power, the inverter control board has a small current flowing into it to be prepared for operation when needed. Due to this, the control board components have to be cooled even when the unit is not running. For this cooling operation, the outdoor unit fan may come on at any time, including in the winter months. Any obstruction to the outdoor fan should be avoided at all times when the unit is powered to prevent damage.

The successful development of hermetically sealed refrigeration compressors has completely sealed the compressor's moving parts and electric motor inside a common housing, minimizing refrigerant leaks and the hazards sometimes associated with moving belts, pulleys or couplings.

Fundamental to the design of hermetic compressors is a method whereby electrical current is transmitted to the compressor motor through terminal conductors which pass through the compressor housing wall. These terminals are sealed in a dielectric material which insulates them from the housing and maintains the pressure tight integrity of the hermetic compressor. The terminals and their dielectric embedment are strongly constructed, but are vulnerable to careless compressor installation or maintenance procedures and equally vulnerable to internal electrical short circuits caused by excessive system contaminants.

In either of these instances, an electrical short between the terminal and the compressor housing may result in the loss of integrity between the terminal and its dielectric embedment. This loss may cause the terminals to be expelled, thereby venting the vaporous and liquid contents of the compressor housing and system.

A venting compressor terminal normally presents no danger to anyone, providing the terminal protective cover is properly in place.

If, however, the terminal protective cover is not properly in place, a venting terminal may discharge a combination of

- (a) hot lubricating oil and refrigerant
- (b) flammable mixture (if system is contaminated with air)

in a stream of spray which may be dangerous to anyone in the vicinity. Death or serious bodily injury could occur.

Under no circumstances is a hermetic compressor to be electrically energized and/or operated without having the terminal protective cover properly in place.

See Service Section S-17 for proper servicing.

# TESTING CAPACITOR DC VOLTAGE



## WARNING

AVOID CONTACT WITH THE CHARGED AREA.

• NEVER TOUCH THE CHARGED AREA BEFORE CONFIRMING THAT THE RESIDUAL VOLTAGE IS 50 VOLTS OR LESS.

1. SHUT DOWN THE POWER AND LEAVE THE CONTROL BOX FOR 10 MINUTES.
2. MAKE SURE TO TOUCH THE EARTH GROUND TERMINAL TO RELEASE THE STATIC ELECTRICITY FROM YOUR BODY (TO PREVENT FAILURE OF THE CONTROL BOARD).
3. MEASURE THE RESIDUAL VOLTAGE IN THE SPECIFIED MEASUREMENT POSITION USING A VOM WHILE PAYING ATTENTION NOT TO TOUCH THE CHARGED AREA.
4. IMMEDIATELY AFTER MEASURING THE RESIDUAL VOLTAGE, DISCONNECT THE CONNECTORS OF THE OUTDOOR UNIT'S FAN MOTOR. (IF THE FAN BLADE ROTATES BY STRONG WIND BLOWING AGAINST IT, THE CAPACITOR WILL BE CHARGED, CAUSING THE DANGER OF ELECTRICAL SHOCK.)

## 1.5 - 3.0 ton models and 2.0 ton Enhanced Capacity/High Efficiency models

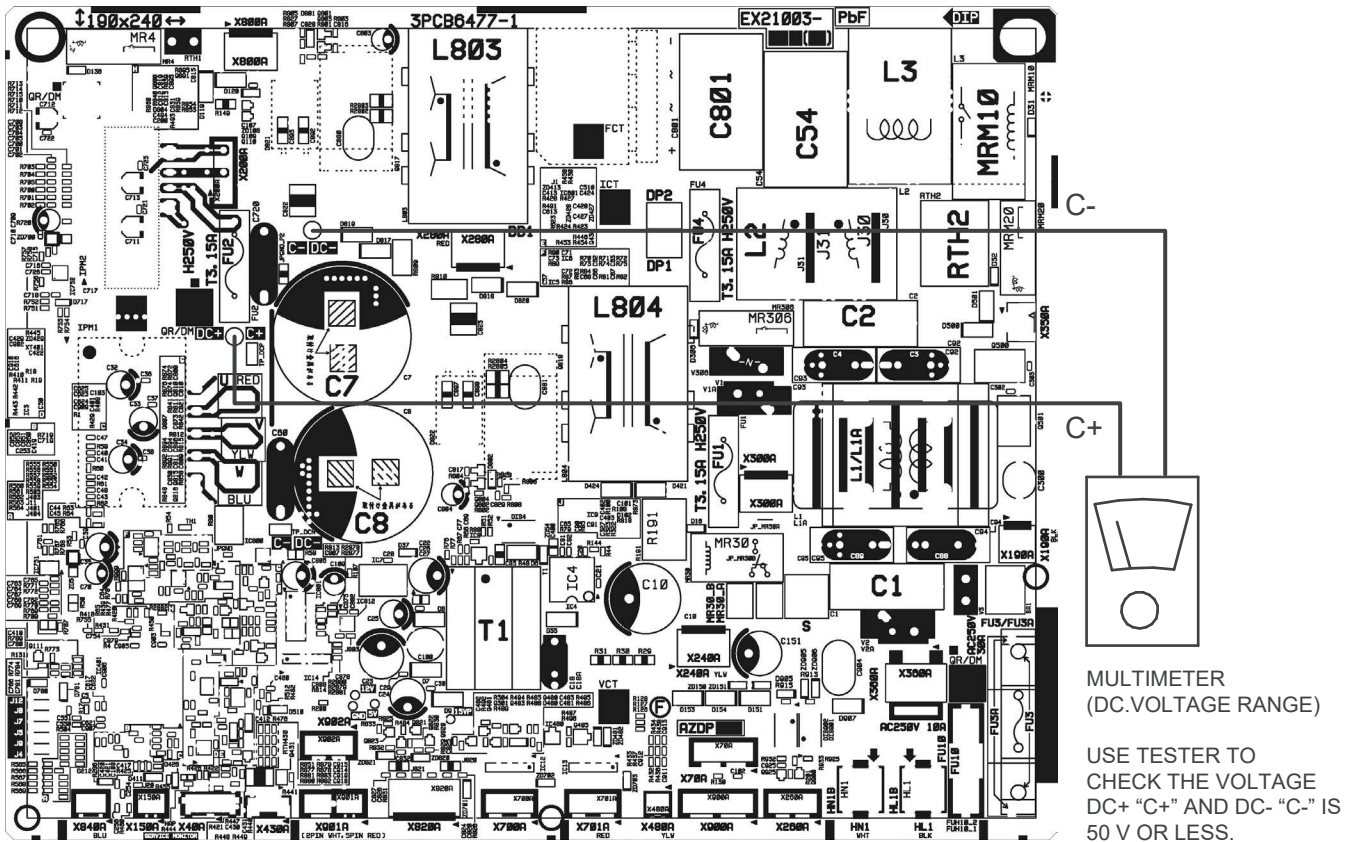

Capacitor Voltage



# SYSTEM OPERATION

This section gives a basic description of unit operation, its various components and their basic operation. Ensure your system is properly sized for heat gain and loss according to methods of the Air Conditioning Contractors Association (ACCA) or equivalent.

## CONDENSING UNIT

The outdoor air is pulled through the outdoor coil by a direct drive propeller fan. This outdoor air is discharged to the side of the cabinet. These units are designed for free air discharge, so no additional resistance, like duct work, shall be attached.

The gas and liquid line connections are brazing type for field piping with refrigerant type copper. Stop valves are factory installed to accept the field run copper.

Outdoor AC and HP models are available in 1.5 through 5.0 ton sizes and use R32 refrigerant. They are designed for 208/230 volt single phase applications.

Outdoor AC and HP R32 model units use a Daikin rotary compressor.

There are a number of design characteristics which are different from the traditional reciprocating and/or scroll compressors.

Outdoor AC and HP models use "FW68DE" which is **NOT** compatible with mineral oil based lubricants like 3GS. "FW68DE" oil (required by the manufacturer) must be used if additional oil is required.

## COOLING

The refrigerant used in the system is R32. It is a clear, colorless, non-toxic and non-irritating liquid. R32 is a single-component refrigerant. The boiling point at atmospheric pressure is **-61.06°F**.

A few of the important principles that make the refrigeration cycle possible are: heat always flows from a warmer to a cooler body. Under lower pressure, a refrigerant will absorb heat and vaporize at a low temperature. The vapors may be drawn off and condensed at a higher pressure and temperature to be used again.

The indoor evaporator coil functions to cool and dehumidify the air conditioned spaces through the evaporative process taking place within the coil tubes.

Liquid refrigerant at condensing pressure and temperatures leaves the outdoor condenser coil through the drier and is metered into the indoor coil through the metering device. As the cool, low pressure, saturated refrigerant enters the tubes of the indoor coil, a portion of the liquid immediately vaporizes. It continues to soak up heat and vaporizes as it proceeds through the coil.

Heat is continually being transferred to the cool fins and tubes of the indoor evaporator coil by the warm system air. This warming process causes the refrigerant to boil. The heat removed from the air is carried off by the vapor.

As the vapor passes through the last tubes of the coil, it becomes superheated. That is, it absorbs more heat than is necessary to vaporize it. This is assurance that only dry gas will reach the compressor. Liquid reaching the compressor can weaken or break compressor valves.

The compressor increases the pressure of the gas, thus adding more heat, and discharges hot, high pressure superheated gas into the outdoor condenser coil.

In the condenser coil, the hot refrigerant gas, being warmer than the outdoor air, first loses its superheat by heat transferred from the gas through the tubes and fins of the coil. The refrigerant now becomes saturated, part liquid, part vapor and then continues to give up heat until it condenses to a liquid alone. Once the vapor is fully liquefied, it continues to give up heat which subcools the liquid, and it is ready to repeat the cycle.

The inverter system can stop the compressor or outdoor fan to protect the unit. The inverter system can run higher compressor speed than required from thermostat to recover compressor oil that flows.

## HEATING

The heating portion of the refrigeration cycle is similar to the cooling cycle. By de-energizing the reversing valve solenoid coil, the flow of the refrigerant is reversed. The indoor coil now becomes the condenser coil, and the outdoor coil becomes the evaporator coil. The check valve at the outdoor coil will be forced closed by the refrigerant flow, thereby utilizing the outdoor expansion device. An electronic expansion valve meters the condensed refrigerant to the outdoor coil.

## DEFROST CYCLE

The defrosting of the outdoor coil is controlled by the control board. Defrost timing periods of 30, 60, 90 or 120 minutes may be selected via the thermostat setting. Control board will initiate time defrost at the interval selected from the thermostat. During operation, the microprocessor on the control board checks the coil. When the control board detects the coil temperature to be high enough, the defrost cycle is terminated and the timing period is reset. The field service personnel can also advance a heat pump to the defrost cycle by selecting "force defrost" option from thermostat.

## SH CONTROL

The target Super Heat (SH) is obtained from following, and the Electronic Expansion Valve (EEV) opening is adjusted so that the actual SH approaches the target SH.

[SH Control (1)]

Target SH = 5°C (9°F)\*

SH = Indoor gas temp. – Evaporator temp.

\*When outdoor air temperature is less than 21°C (70°F), target SH is 8°C (14°F).

[SH Control (2)]

Target SH = 4°C (7°F)

SH = Suction temp – Outdoor coil middle temp.

	Cooling	Heating
Indoor EEV	SH Control (1)	Fully open (480 pls)
Outdoor EEV	Fully open (480 pls)	SH Control (2)

# SYSTEM OPERATION

## PIPING DIAGRAMS

### AC 1.5 - 3.0 ton models

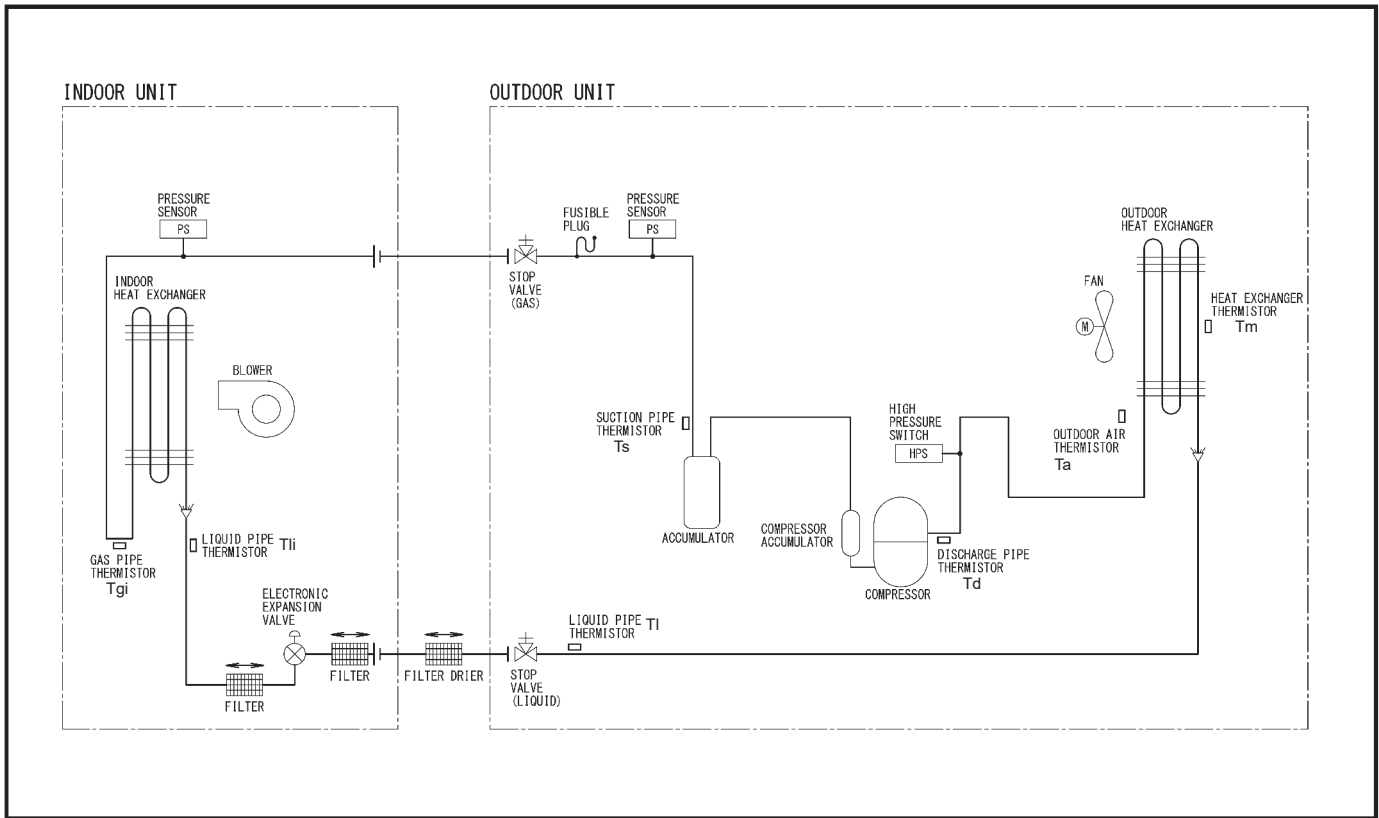

### AC 3.5 - 5.0 ton models

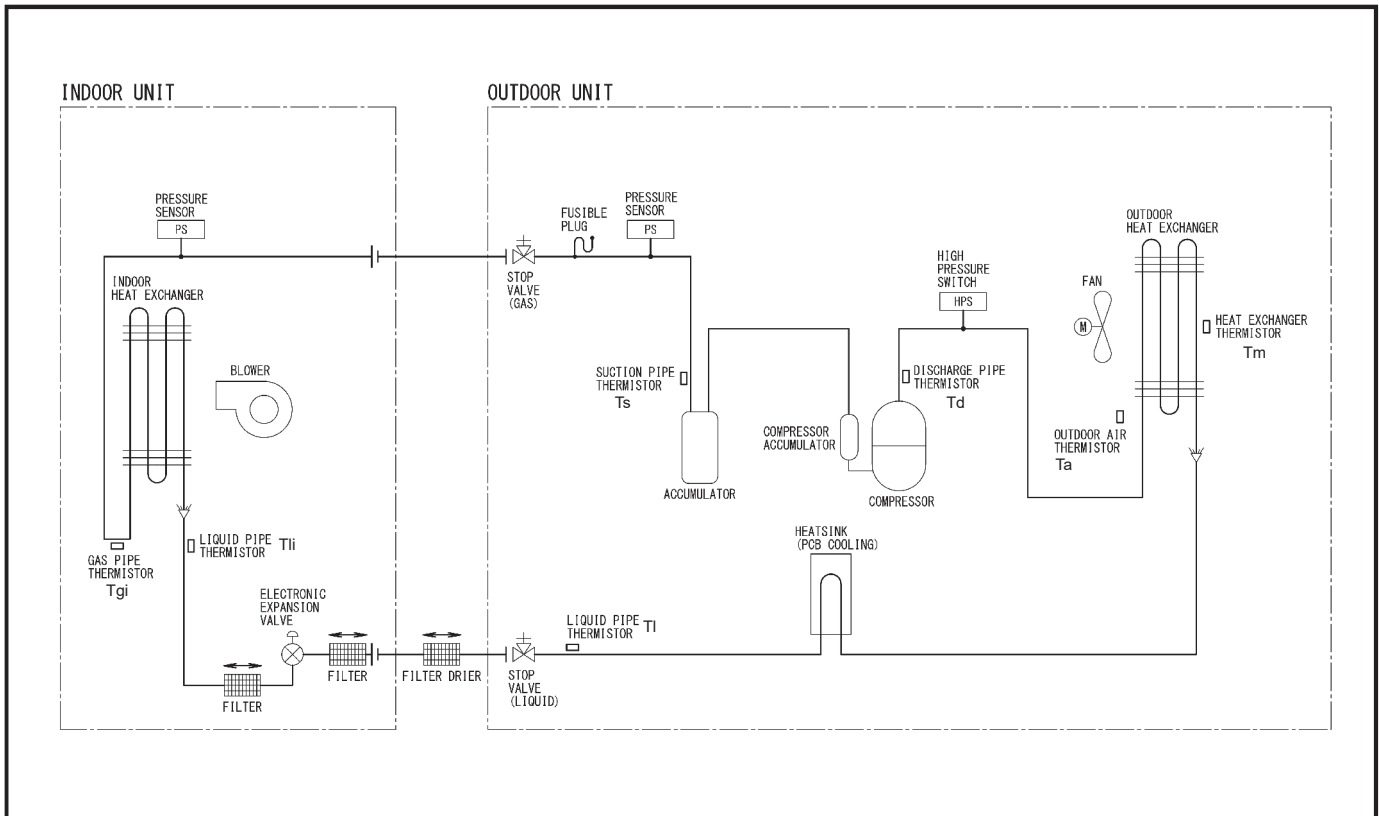

# SYSTEM OPERATION

## PIPING DIAGRAMS

### 1.5 - 3.0 ton models HP and 2.0 ton Enhanced Capacity models

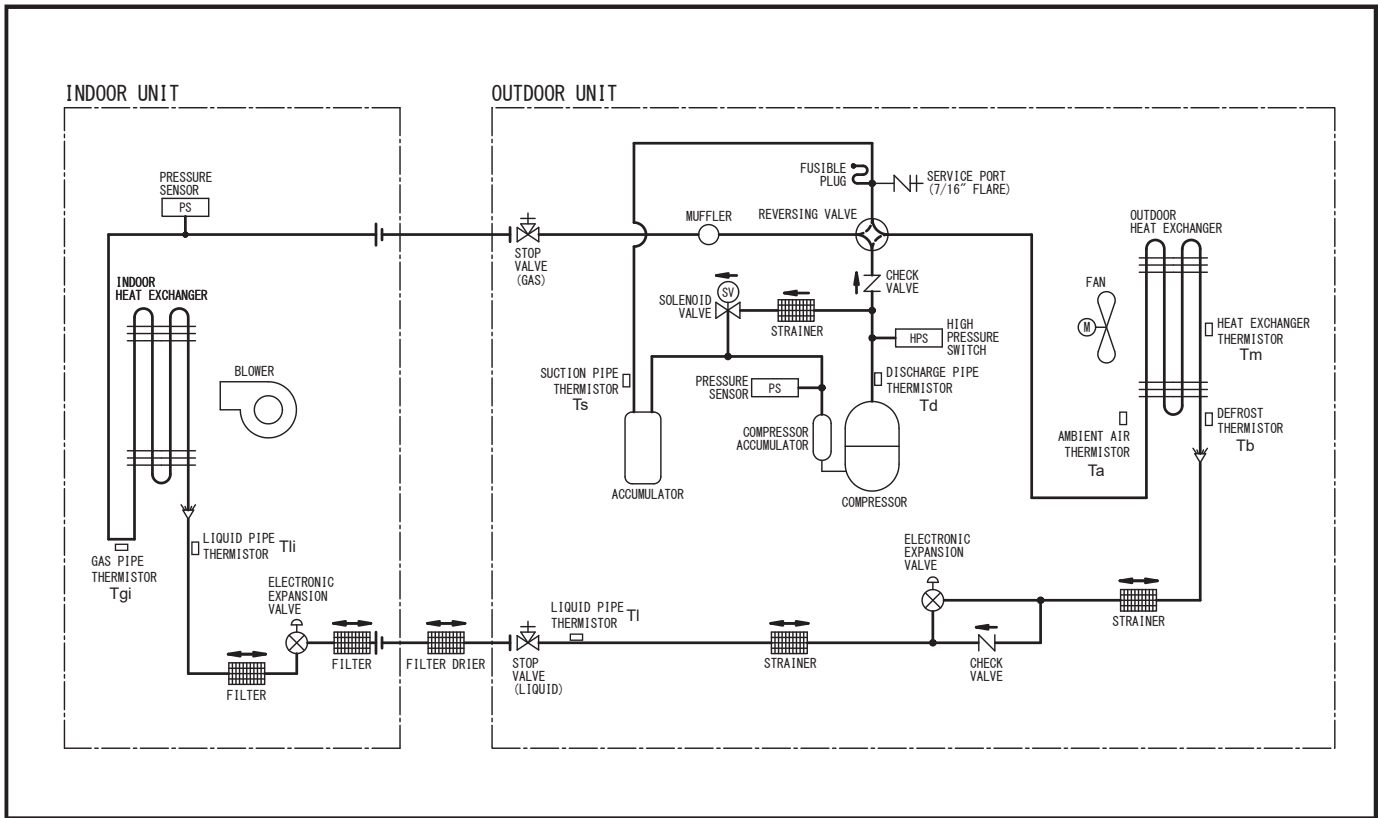

### 3.5 - 5.0 ton models HP and 3.0 - 4.0 ton Enhanced Capacity models

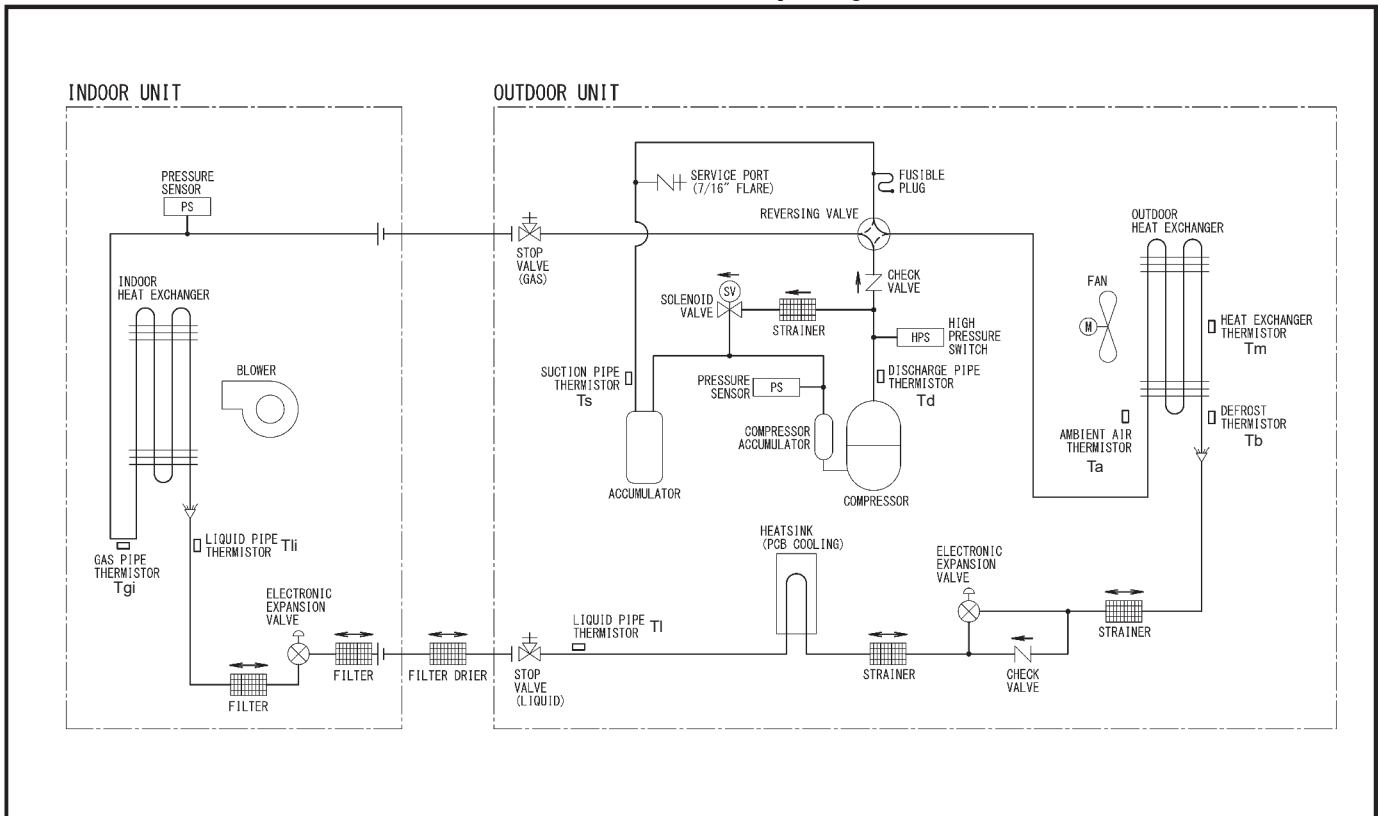

# SYSTEM OPERATION

## COOLING OPERATION FLOW

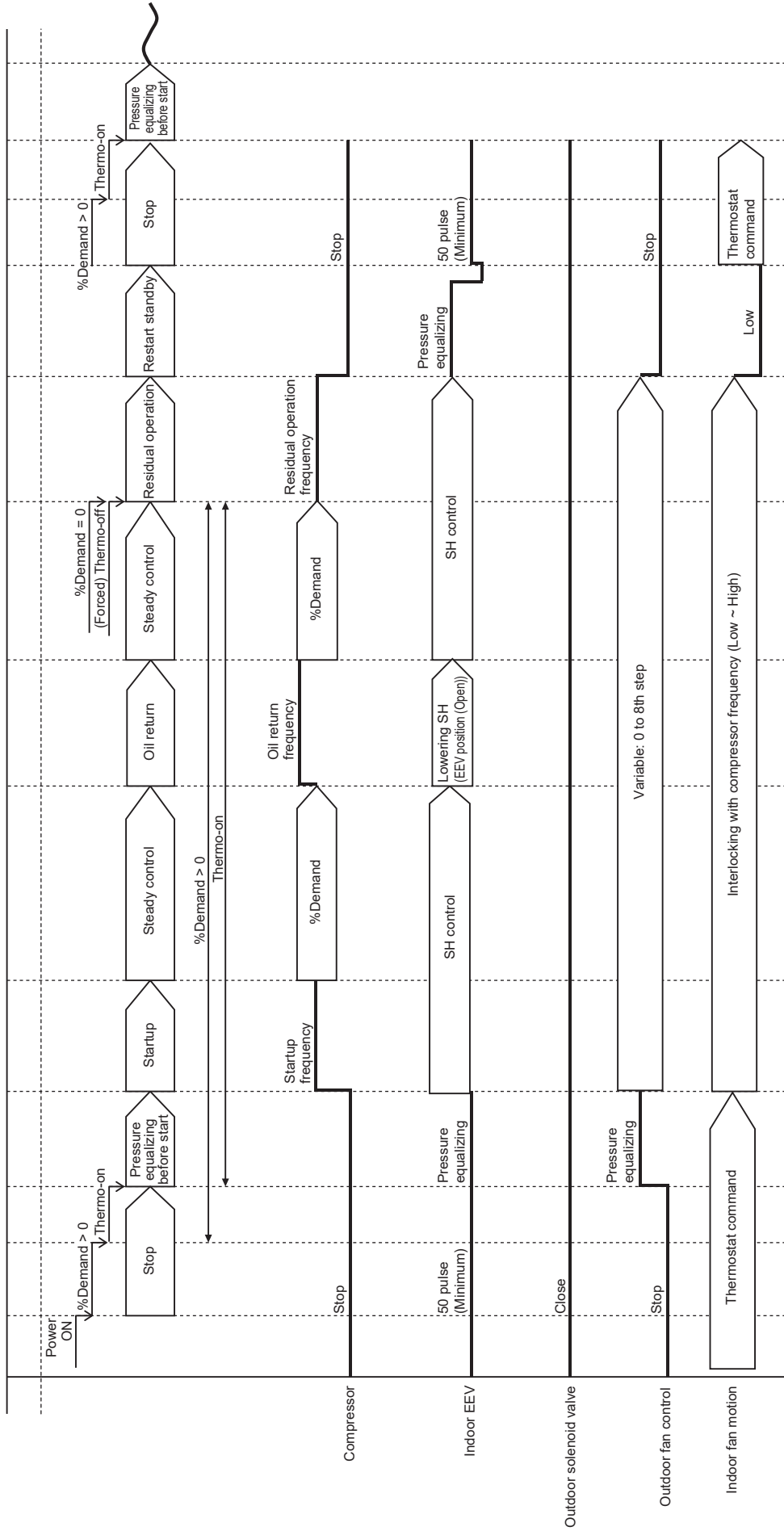

# SYSTEM OPERATION

## HEATING OPERATION FLOW

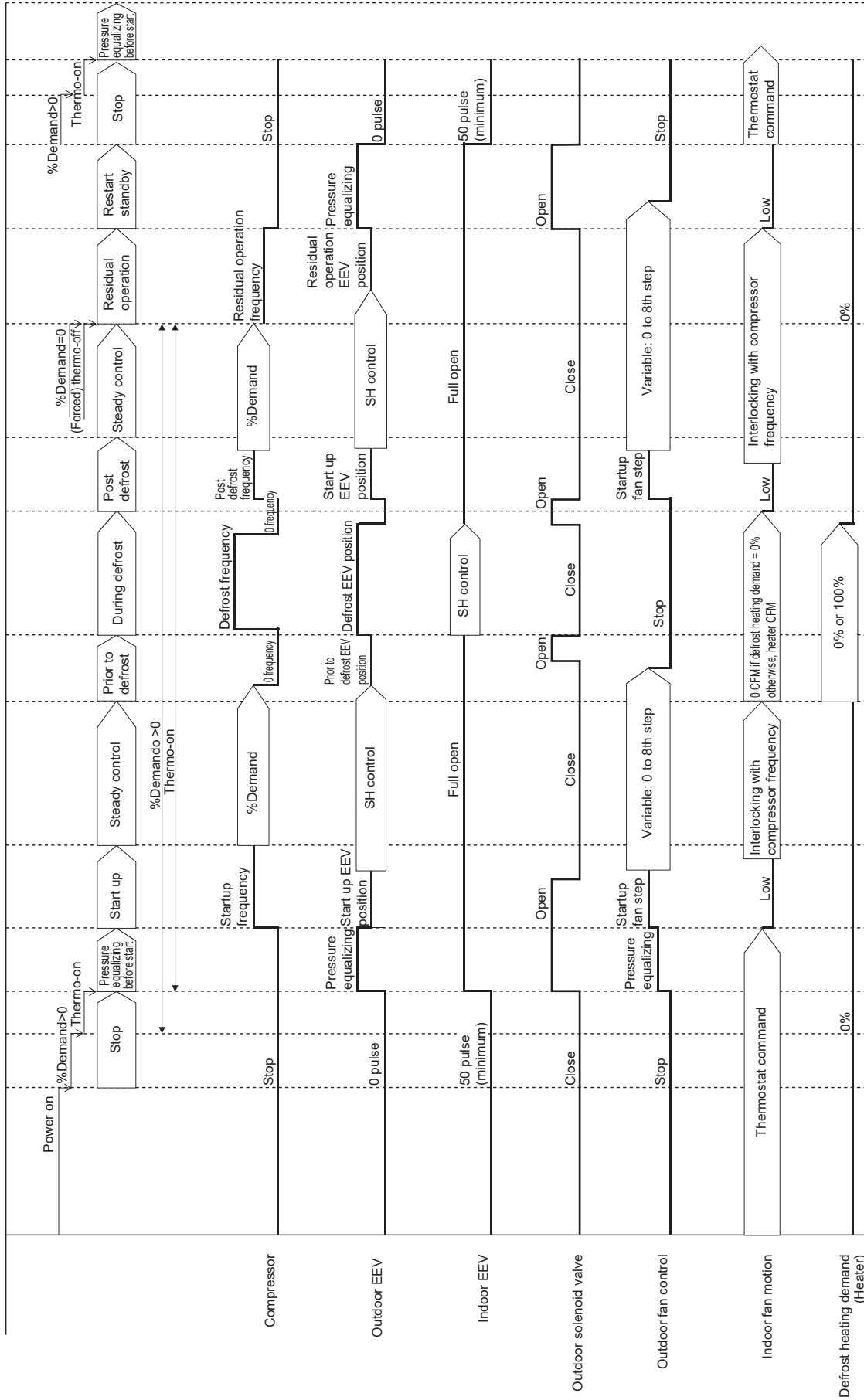

# SERVICING

## TABLE OF CONTENTS

S-1	CHECKING VOLTAGE .....	13	S-26	TESTING THERMISTOR, EEV COIL AND SOLENOID VALVE COIL RESISTANCE .....	19
S-2	CHECKING WIRING .....	13	S-100	REFRIGERATION REPAIR PRACTICE .....	20
S-3E	GOODMAN GTST CONNECTED THERMOSTAT .....	13	S-104	CHECKING COMPRESSOR EFFICIENCY...	20
S-4	CHECKING TRANSFORMER AND CONTROL CIRCUIT .....	14	S-114	NON-CONDENSABLE .....	21
S-12	CHECKING HIGH PRESSURE SWITCH .....	14	S-115	COMPRESSOR BURNOUT.....	21
S-13	CHECKING INDOOR UNIT / OUTDOOR UNIT PRESSURE SENSOR.....	15	S-202	DUCT STATIC PRESSURES AND/OR STATIC PRESSURE DROP ACROSS COILS .....	21
S-16G	CHECKING ECM MOTORS .....	15	S-203	AIR HANDLER EXTERNAL STATIC .....	21
S-17	CHECKING COMPRESSOR .....	18	S-203A	TWO PIECE INDOOR UNIT EXTERNAL STATIC .....	22
S-17A	RESISTANCE TEST .....	18		CHECKING LEAK DETECTION OUTPUT (AIR HANDLER).....	23
S-17B	GROUND TEST .....	19			

**NOTE:** Please refer to the Service Manual of each unit about the Gas Furnaces and Modular Blower.



### WARNING

#### HIGH VOLTAGE!

Disconnect ALL power before servicing or installing. Multiple power sources may be present. Failure to do so may cause property damage, personal injury or death.



# SERVICING

## S-1 CHECKING VOLTAGE

1. Remove outer case, control panel cover, etc., from unit being tested.

With power ON:



**WARNING**

**LINE VOLTAGE NOW PRESENT.**

2. Using a voltmeter, measure the voltage across L1 and L2 terminals of outdoor unit or at the field connections for the indoor units or heaters.
3. No reading - indicates open wiring, open fuse(s), no power or etc., from unit to fused disconnect service. Repair as needed.
4. With ample voltage at line voltage connectors, energize the unit.

Unit Type	Unit Supply Voltage (VAC)		
	Voltage	Min.	Max.
EEV Air Handler, Modular Blower	208/230	197	253
115 V EEV Air Handler	115	103	126
Gas Furnaces	115	103 </td <td>126</td>	126
EEV Cased Coil	24	22.6	25.5
Outdoor Unit	208/230	197	253

## S-2 CHECKING WIRING

**WARNING**

**HIGH VOLTAGE !**

**DISCONNECT ALL POWER BEFORE SERVICING OR INSTALLING. MULTIPLE POWER SOURCES MAY BE PRESENT. FAILURE TO DO SO MAY CAUSE PROPERTY DAMAGE, PERSONAL INJURY OR DEATH.**



1. Check wiring visually for signs of overheating, damaged insulation and loose connections.
2. Use an ohmmeter to check continuity of any suspected open wires.
3. If any wires must be replaced, replace with comparable gauge and insulation thickness.

## S-3E GOODMAN GTST CONNECTED THERMOSTAT

Typical wiring will consist of two wires between the indoor unit and outdoor unit, and four wires between the indoor unit and thermostat. The figure that follows shows the required wires: data lines, 1 and 2; "R" (24 VAC hot) and "C" (24 VAC common).

### <In Case of EEV Air Handler>

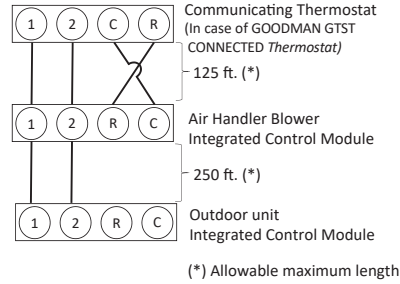

### <In Case of EEV Cased Coil>

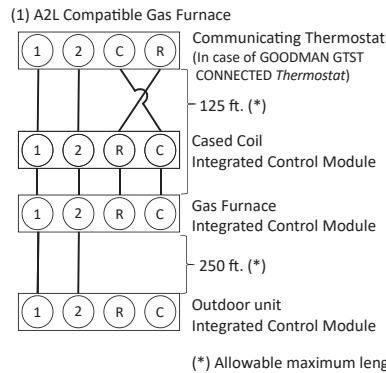

### (2) Non-A2L Compatible Gas Furnace or Modular Blower (\*1)

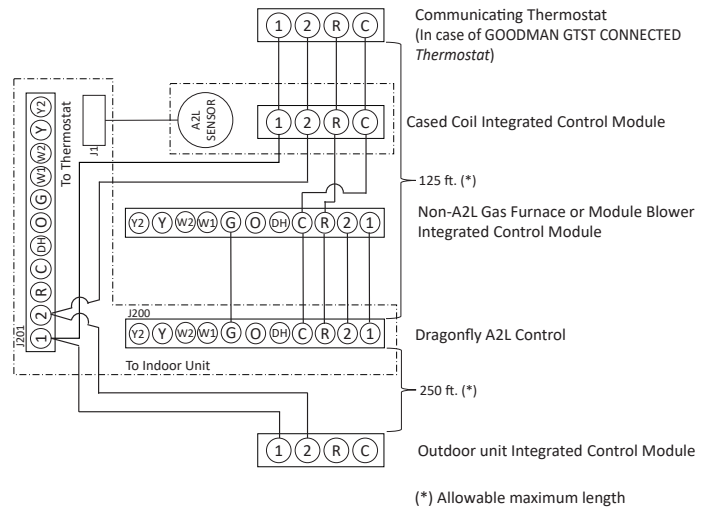

(\*1) NOTE: In case of using non-A2L Compatible gas furnace or modular blower, refer to "NON-A2L GAS FURNACE INTEGRATION KIT (DRAGONFLY KIT)" for details.

It is **strongly** recommended that you do not connect more than two wires into a single terminal in the field because there is a risk of the wires becoming loose, which may result in intermittent operation.

To wire the system components, it is strongly recommended to use the same type and same gauge for the wires prepared in the field. (For best results, use 18 AWG.) However, communications reliability may be improved by using a high quality, shielded, twisted pair cable for the data transmission lines. Finally, be sure to confirm that the wires do not come off each terminal after all connections are finished.

# SERVICING

## S-4 CHECKING TRANSFORMER AND CONTROL CIRCUIT

 **WARNING**

**HIGH VOLTAGE !**  
DISCONNECT ALL POWER BEFORE SERVICING OR INSTALLING. MULTIPLE POWER SOURCES MAY BE PRESENT. FAILURE TO DO SO MAY CAUSE PROPERTY DAMAGE, PERSONAL INJURY OR DEATH.



A step-down transformer (208/230 or 115 volt primary to 24 volt secondary) is provided with each indoor unit. This allow ample capacity for use with resistant heaters only for 208/230 V Air Handler models. Air Handler with 115 V transformer cannot be installed with any heater kit. The outdoor sections do not contain a transformer (see indoor unit WIRING DIAGRAMS on page 80 to 82).

 **WARNING**

**DISCONNECT ALL POWER BEFORE SERVICING.**

1. Remove control panel cover, or etc., to gain access to transformer.

With power ON:

 **WARNING**

**LINE VOLTAGE NOW PRESENT.**

2. Using a voltmeter, check voltage across secondary voltage side of transformer (R to C).
3. No voltage indicates faulty transformer, bad wiring, or bad splices.
4. Check transformer primary voltage at incoming line voltage connections and/or splices.
5. If line voltage available at primary voltage side of transformer and wiring and splices are good, transformer is inoperative. Replace the transformer.

## S-12 CHECKING HIGH PRESSURE SWITCH

 **WARNING**

**HIGH VOLTAGE !**  
DISCONNECT ALL POWER BEFORE SERVICING OR INSTALLING. MULTIPLE POWER SOURCES MAY BE PRESENT. FAILURE TO DO SO MAY CAUSE PROPERTY DAMAGE, PERSONAL INJURY OR DEATH.



The high pressure switch senses the pressure in the compressor discharge line. If abnormally high condensing pressures develop, the contacts of the switch open, breaking the control circuit before the compressor motor overloads. The high pressure switch cut off pressure is 4.2 MPa (605 PSIG) and cut in pressure is 3.2 MPa (465 PSIG), however this control is not automatically reset and will need to turn main power OFF to reset.

Using an ohmmeter, check across PCB side terminals of high pressure switch wiring with wire on PCB side removed. If not continuous, the circuit is open. Replace if necessary.

# SERVICING

## S-13 CHECKING INDOOR UNIT / OUTDOOR UNIT PRESSURE SENSOR

With power ON:

 **WARNING**

LINE VOLTAGE NOW PRESENT.

The outdoor and indoor pressure sensor senses low pressure or high pressure.

Follow the following sequence to check the pressure sensor.

1. Connect a voltmeter across the sensor terminals between black and white wirings. The voltmeter should show the voltage in the following table.
2. Replace the sensor if the sensor is open, shorted or outside the valid voltage range.

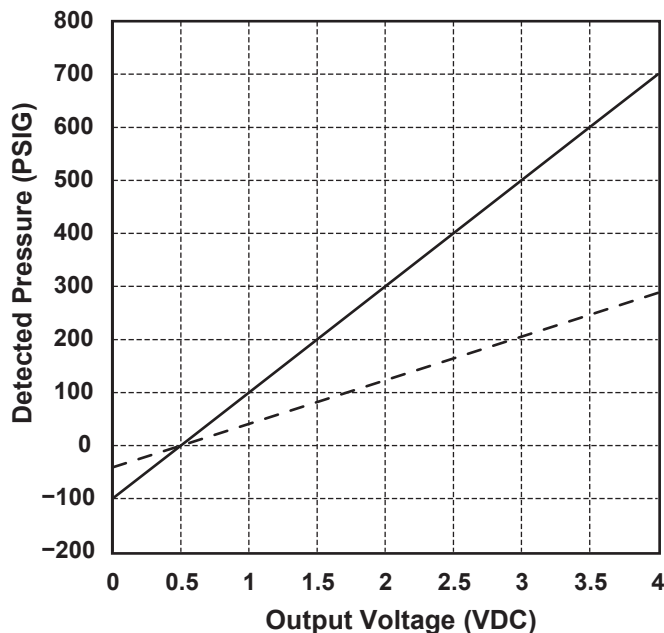

- Outdoor unit (3.5 - 5.0 ton models and 3.0 - 4.0 ton Enhanced Capacity/High Efficiency models) and Indoor unit.
- - - Outdoor unit (1.5 - 3.0 ton models and 2.0 ton Enhanced Capacity/High Efficiency models)

### VOLTAGE VS PRESSURE CHARACTERISTICS

## S-16G CHECKING ECM MOTORS

### DESCRIPTION

The indoor unit utilizes a 4-wire variable speed ECM blower motor. The ECM blower motor provides constant CFM.

The motor is a serially communicating variable speed motor. Only four wires are required to control the motor: +Vdc, Common, Receive, and Transmit

The +Vdc and Common wires provide power to the motor's low voltage control circuits.

### General Checks/Considerations

1. Check power supply to the indoor unit. Ensure power supply is within the range specified on rating plate. See section S-1.
2. Check motor power harness. Ensure wires are continuous and make good contact when seated in the connectors. Repair or replace as needed.
3. Check motor control harness. Ensure wires are continuous and make good contact when seated in the connectors. Repair or replace as needed.
4. Check thermostat and thermostat wiring. Ensure thermostat is providing proper cooling/heating/continuous fan demands. Repair or replace as needed.
5. Check blower wheel. Confirm wheel is properly seated on motor shaft. Set screw must be on shaft flat and torqued to 165 in-lbs minimum. Confirm wheel has no broken or loose blades. Repair or replace as needed.
6. Ensure motor and wheel turn freely. Check for interference between wheel and housing or wheel and motor. Repair or replace as needed.
7. Check housing for cracks and/or corrosion. Repair or replace as needed.
8. Check motor mounting bracket. Ensure mounting bracket is tightly secured to the housing. Ensure bracket is not cracked or broken.

### Nidec UltraCheck-EZ™ Diagnostic Tool

The Nidec UltraCheck-EZ™ diagnostic tool may be used to diagnose the ECM motor.

 **WARNING**

**HIGH VOLTAGE!**  
Disconnect ALL power before servicing or installing. Multiple power sources may be present. Failure to do so may cause property damage, personal injury or death.



# SERVICING

To use the diagnostic tool, perform the following steps:

1. Disconnect power to the indoor unit.
2. Disconnect the 4-circuit control harness from the motor.
3. Plug the 4-circuit connector from the diagnostic tool into the motor control connector.
4. Connect one alligator clip from the diagnostic tool to a ground source.
5. Connect the other alligator clip to a 24VAC source.

**NOTE:** The alligator clips are NOT polarized.

**NOTE:** The UltraCheck-EZ™ diagnostic tool is equipped with a nonreplaceable fuse. Connecting the tool to a source other than 24VAC could damage the tool and cause the fuse to open. Doing so will render the diagnostic tool inoperable.

6. Turn on power to the indoor unit.



**WARNING**  
Line Voltage now present.

7. Depress the orange power button on the diagnostic tool to send a run signal to the motor. Allow up to 5 seconds for the motor to start.

**NOTE:** If the orange power button does not illuminate when depressed, the tool either has an open fuse or is not properly connected to a 24VAC source.

8. The green LED on the diagnostic tool will blink indicating communications between the tool and motor. See table below for indications of tool indicators and motor actions. Replace or repair as needed.

Power Button	Green LED	Motor Action	Indication(s)
OFF	OFF	Not Rotating	Confirm 24VAC to UltraCheck-EZ™ tool. If 24VAC is confirmed, diagnostic tool is inoperable.
ON	Blinking	Rotating	Motor and control/end bell are functioning properly.
ON	OFF	Rotating	Replace motor control/end bell.
ON	Blinking	Not Rotating	Check motor (see <i>Motor Checks</i> on page 17).
ON	OFF	Not Rotating	Replace motor control/end bell; verify motor (see <i>Motor Checks</i> on page 17).

9. Depress the orange power button to turn off motor.
10. Disconnect power. Disconnect diagnostic tool.
11. Reconnect the 4-wire harness from control board to motor.

## Electrical Checks - High Voltage Power Circuits



**WARNING**  
**HIGH VOLTAGE!**  
Disconnect ALL power before servicing or installing. Multiple power sources may be present. Failure to do so may cause property damage, personal injury or death.



1. Disconnect power to the indoor unit.
2. Disconnect the 5-circuit power connector to the ECM motor.
3. Turn on power to the indoor unit.



**WARNING**  
Line Voltage now present.

4. Measure voltage between pins 4 and 5 on the 5-circuit connector. Measured voltage should be the same as the supply voltage to the indoor unit.

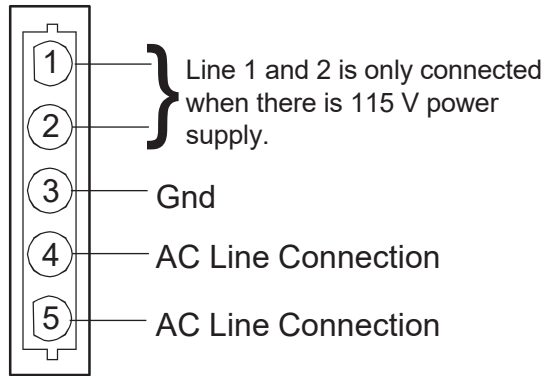

5. Measure voltage between pins 4 and 3. Voltage should be approximately half of the voltage measured in step 4.
6. Measure voltage between pins 5 and 3. Voltage should be approximately half of the voltage measured in step 4.
7. If no voltage is present, check supply voltage to the indoor unit. See section S-1.
8. Disconnect power to the indoor unit. Reconnect the 5-circuit power harness disconnected in step 2.

# SERVICING

## Electrical Checks - Low Voltage Control Circuits

1. Turn on power to the indoor unit.



### WARNING

Line Voltage now present.

2. Check voltage between pins on the 4-wire motor control harness between the motor and control board.
3. Voltage on pins should read:  
Pins 1 to 4 = 3.3 VDC  
Pins 1 to 2 = 3.3 VDC  
Pins 3 to 4 = 15 VDC

## Motor Control/End Bell Checks



### WARNING

#### HIGH VOLTAGE!

Disconnect ALL power before servicing or installing. Multiple power sources may be present. Failure to do so may cause property damage, personal injury or death.



1. Disconnect power to the indoor unit.

**NOTE:** Motor contains capacitors that can hold a charge for several minutes after disconnecting power. Wait 5 minutes after removing power to allow capacitors to discharge.

2. Disconnect the motor control harness and motor power harness.
3. Remove the blower assembly from the indoor unit.
4. Remove the (3) screws securing the control/end bell to the motor. Separate the control/end bell. Disconnect the 3-circuit harness from the control/end bell to remove the control/end bell from the motor.
5. Inspect the NTC thermistor inside the control/end bell (see figure below). Replace control/end bell if thermistor is cracked or broken.

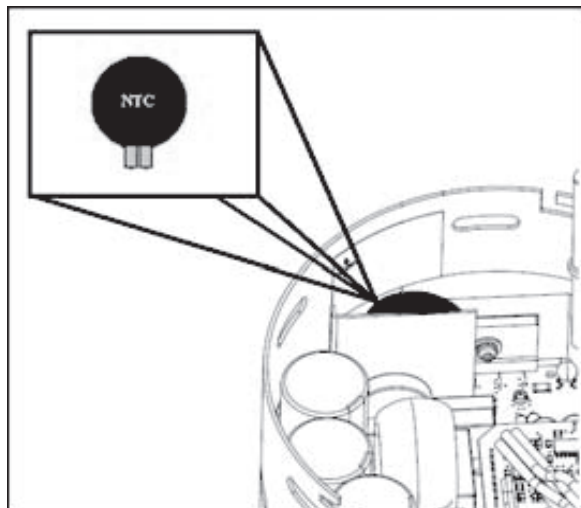

6. Inspect the large capacitors inside the control/end bell (see figure below). Replace the control/end bell if any of the capacitors are bulging or swollen.

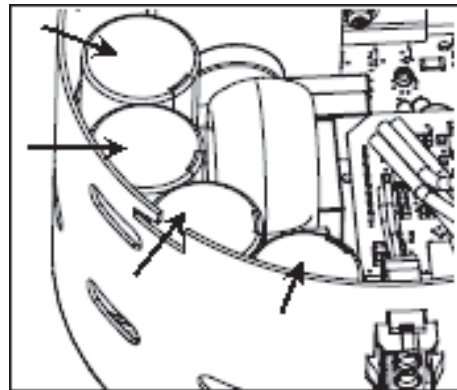

7. Locate the 3-circuit connector in the control/end bell. Using an ohmmeter, check the resistance between each terminal in the connector. If the resistance is 1 MΩ or greater, the control/end bell is functioning properly. Replace the control/end bell if the resistance is lower than 1 MΩ.
8. Reassemble motor and control/end bell in reverse of disassembly. Replace blower assembly into air handler or modular blower.

## Motor Checks



### WARNING

#### HIGH VOLTAGE!

Disconnect ALL power before servicing or installing. Multiple power sources may be present. Failure to do so may cause property damage, personal injury or death.



1. Disconnect power to air handler or modular blower.

**NOTE:** Motor contains capacitors that can hold a charge for several minutes after disconnecting power. Wait 5 minutes after removing power to allow capacitors to discharge.

2. Disassemble motor as described in steps 2 through 4 above.
3. Locate the 3-circuit harness from the motor. Using an ohmmeter, measure the resistance between each motor phase winding. The resistance levels should be equal. Replace the motor if the resistance levels are unequal, open circuited or short circuited.
4. Measure the resistance between each motor phase winding and the motor shell. Replace the motor if any phase winding is short circuited to the motor shell.
5. Reassemble motor and control/end bell in reverse of disassembly. Replace blower assembly into air handler or modular blower.

# SERVICING

## S-17 CHECKING COMPRESSOR

### WARNING

Hermetic compressor electrical terminal venting can be dangerous. When insulating material which supports a hermetic compressor or electrical terminal suddenly disintegrates due to physical abuse or as a result of an electrical short between the terminal and the compressor housing, the terminal may be expelled, venting the vapor and liquid contents of the compressor housing and system.

If the compressor terminal PROTECTIVE COVER and gasket (if required) are not properly in place and secured, there is a remote possibility if a terminal vents, that the vaporous and liquid discharge can be ignited, spouting flames several feet, causing potentially severe or fatal injury to anyone in its path.

This discharge can be ignited external to the compressor if the terminal cover is not properly in place and if the discharge impinges on a sufficient heat source.

Ignition of the discharge can also occur at the venting terminal or inside the compressor, if there is sufficient contaminant air present in the system and an electrical arc occurs as the terminal vents.

Ignition cannot occur at the venting terminal without the presence of contaminant air, and cannot occur externally from the venting terminal without the presence of an external ignition source.

Therefore, proper evacuation of a hermetic system is essential at the time of manufacture and during servicing.

To reduce the possibility of external ignition, all open flame, electrical power, and other heat sources should be extinguished or turned off prior to servicing a system.

## S-17A RESISTANCE TEST

Inverter on the outdoor unit control board takes the position signal from the UVW line connected with the compressor. When the system detects the malfunction on the compressor, check the insulation resistance in accordance with the following procedure.

### WARNING

**HIGH VOLTAGE!**  
Disconnect ALL power before servicing or installing. Multiple power sources may be present. Failure to do so may cause property damage, personal injury or death.



1. Remove the leads from the compressor terminals.

### WARNING

See warnings S-17 before removing compressor terminal cover.

2. Check the wiring connection of UVW on compressor terminal. (The terminal indicated label located on the top of compressor.)
3. Check the insulation resistance of compressor between the compressor terminal and unpainted refrigerant piping.

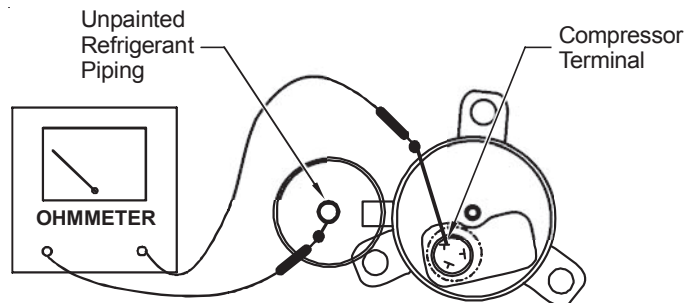

### TESTING COMPRESSOR WINDINGS

**NOTE:** The compressor has terminal on the top.

4. If the insulation resistance of compressor is less than 30 MΩ, replace the compressor.

# SERVICING

## S-17B GROUND TEST

If fuse, circuit breaker, etc., has tripped, this is a strong indication that an electrical problem exists and must be found and corrected. The circuit protective device rating must be checked, and its maximum rating should coincide with that marked on the equipment nameplate.

With the terminal protective cover in place, it is acceptable to replace the fuse or reset the circuit breaker ONE TIME ONLY to see if it was just a nuisance opening. If it opens again, DO NOT continue to reset.

**Disconnect all power to unit**, making sure that **all** power legs are open.

1. DO NOT remove protective terminal cover. Disconnect the three leads going to the compressor terminals at the nearest point to the compressor.
2. Identify the leads and using an ohmmeter on the R x 10,000 scale or the highest resistance scale on your ohmmeter check the resistance between each of the three leads separately to ground (such as an unpainted tube on the compressor).
3. If a ground is indicated, then carefully remove the compressor terminal protective cover and inspect for loose leads or insulation breaks in the lead wires.
4. If no visual problems indicated, carefully remove the leads at the compressor terminals.
5. Carefully retest for ground, directly between compressor terminals and ground.
6. If ground is indicated, replace the compressor. The resistance reading should be infinity. If there is any reading on meter, there is some continuity to ground and compressor should be considered defective.



**WARNING**

Damage can occur to the glass embedded terminals if the leads are not properly removed. This can result in terminal and hot oil discharging.

## S-26 TESTING THERMISTOR, EEV COIL AND SOLENOID VALVE COIL RESISTANCE

Outdoor units and EEV indoor units are factory equipped with:

- (Ta) an outdoor air thermistor
- (Tm) an outdoor heat exchanger thermistor
- (TI) an outdoor liquid thermistor
- (Td) an outdoor discharge thermistor
- (Tb) an outdoor coil defrost thermistor
- (Ts) an outdoor suction thermistor
- (Tgi) an indoor gas thermistor
- (Tli) an indoor liquid thermistor

To check these thermistors:



**WARNING**

**HIGH VOLTAGE!**  
Disconnect ALL power before servicing or installing. Multiple power sources may be present. Failure to do so may cause property damage, personal injury or death.



1. Disconnect power to all equipments.
2. Disconnect the thermistor connector from the control board.
3. Connect an ohmmeter across the thermistor terminals. The ohmmeter should read the resistance shown in the table THERMISTOR RESISTANCE AND TEMPERATURE CHARACTERISTICS. Replace the thermistor if the thermistor is open, shorted, or outside the valid resistance range.

### Testing EEV Coil Resistance

To check the resistance of the EEV coil, first disconnect the EEV cable from the control board. Read resistance between the connector pins, and then make sure the resistance falls in the range of 40 to 50 Ω.

Outdoor unit (HP): 1.5 - 3.0 ton models and 2.0 ton Enhanced Capacity/High Efficiency models.

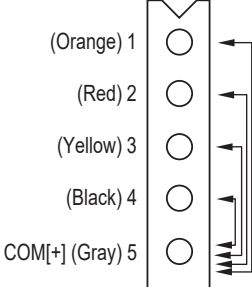

Measuring points	Judgement criteria
1-5	40~50Ω
2-5	
3-5	
4-5	

Outdoor unit (HP): 3.5 - 5.0 ton models and 3.0 - 4.0 ton Enhanced Capacity/High Efficiency models, Indoor unit

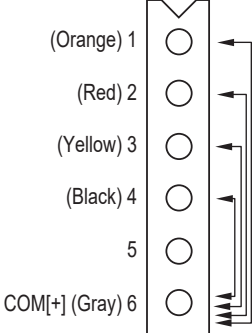

Measuring points	Judgement criteria
1-6	40~50Ω
2-6	
3-6	
4-6	

### Testing Solenoid Valve Coil Resistance

To check the resistance of the solenoid valve coil, first disconnect the cable from the control board. Read resistance between the connector pins, and then make sure the resistance falls in the range of 1,480 to 1,820 Ω.

# SERVICING

## S-100 REFRIGERATION REPAIR PRACTICE



### DANGER

Always remove the refrigerant charge in a proper manner before applying heat to the system.



### NOTICE

There is no specific "Pump down" function. When the unit needs to be removed/relocated, please recover all refrigerant from the system. Use the service ports (2 locations) on the stop valves to recover refrigerant. You may not recover all refrigerant unless you use the 2 service ports.

When repairing the refrigeration system:



### WARNING

#### HIGH VOLTAGE!

Disconnect ALL power before servicing or installing. Multiple power sources may be present. Failure to do so may cause property damage, personal injury or death.



1. Never open a system that is under vacuum. Air and moisture will be drawn in.
2. Plug or cap all openings.
3. Remove all burrs and clean the brazing surfaces of the tubing with sand cloth or paper. Brazing materials do not flow well on oxidized or oily surfaces.
4. Clean the inside of all new tubing to remove oils and pipe chips.
5. When brazing, sweep the tubing with dry nitrogen to prevent the formation of oxides on the inside surfaces.
6. Complete any repair by replacing the liquid line drier in the system, evacuate and charge.

### BRAZING MATERIALS

**IMPORTANT NOTE:** Torch heat required to braze tubes of various sizes is proportional to the size of the tube. Tubes of smaller size require less heat to bring the tube to brazing temperature before adding brazing alloy. Applying too much heat to any tube can melt the tube. Service personnel must use the appropriate heat level for the size of the tube being brazed.

**NOTE:** The use of a heat shield when brazing is recommended to avoid burning the serial plate or the finish on the unit. Heat trap or wet rags should be used to protect heat sensitive components such as stop valves, EEV and filters.

**Copper to Copper Joints** - Sil-Fos used without flux (alloy of 15% silver, 80% copper, and 5% phosphorous). Recommended heat 1400°F.

**Copper to Steel Joints** - Silver Solder used without a flux (alloy of 30% silver, 38% copper, 32% zinc). Recommended heat - 1200°F.

## S-104 CHECKING COMPRESSOR EFFICIENCY

The reason for compressor inefficiency is that the compressor is broken or damaged, reducing the ability of the compressor to pump refrigerant vapor.

Confirm the following points before testing compressor:

1. Indoor airflow is correct, and static is not too high.
2. Outdoor coil has no debris lodged in the fins and is clean.
3. There is no air re-circulation, and installation clearance is sufficient.
4. There is no leak in the system and the refrigerant charge is correct.

If all the above points are confirmed, proceed with the compressor test using the below instructions:

1. Attach gauges to high and low side of the system.
2. Start the system and run Charge Verification Test. Give the system 20-25 minutes to stabilize.
3. Check the thermostat display to make sure it isn't displaying "Comp speed out of range". If so, refer to the Charge Verification test troubleshooting section in this manual for possible corrective actions.
4. Check the following during the test:
  - a. Convert high side pressure measured to temperature using R32 pressure-temperature chart provided in this manual. This temperature should be at least 10°F higher than AMBIENT temperature (5°F if it is a 1.5 ton unit).
  - b. Convert low side pressure to temperature using R32 pressure-temperature chart provided in this manual. This temperature should be at least 15°F lower than INDOOR temperature, this temperature should be measured ~12" from inlet to indoor unit.

If any one OR both of (a) & (b) don't satisfy, compressor might be faulty.

**NOTE:** Using Charge Verification Test for the above purpose is only advised from 65°F-115°F Ambient temperatures, while Subcooling adjustment using Charge Verification Test is only valid from 65°F-105°F Ambient temperatures.

# SERVICING

## S-114 NON-CONDENSABLE

If non-condensable is suspected, measure the pressure in the condenser (coil on high temperature side). If the pressure is abnormally high during normal operation, non-condensable may be present.

Non-condensable is removed from the system by first removing the refrigerant charge, replacing and/or installing liquid line drier, evacuating and recharging.

## S-115 COMPRESSOR BURNOUT

When a compressor burns out, high temperature develops causing the refrigerant, oil and motor insulation to decompose forming acids and sludge.

If a compressor is suspected of being burned out, confirm by analyzing an oil sample using an Oil acid test kit.

If acid level is unacceptable, replace the compressor and the system must be cleaned by using the clean-up drier method.

**NOTICE**  
Violation of EPA regulations may result in fines or other penalties.

**CAUTION**  
Do not allow the sludge or oil to contact the skin. Severe burns may result.

## S-202 DUCT STATIC PRESSURES AND/OR STATIC PRESSURE DROP ACROSS COILS

This minimum and maximum allowable duct static pressure for the indoor sections are found in the specifications section.

Tables are also provided for each coil, listing quantity of air (CFM) versus static pressure drop across the coil.

Too great an external static pressure will result in insufficient air that can cause icing of the coil. Too much air can cause poor humidity control and condensate to be pulled off the evaporator coil causing condensate leakage. Too much air can also cause motor overloading and in many cases this constitutes a poorly designed system.

## S-203 AIR HANDLER EXTERNAL STATIC

To determine proper air movement, proceed as follows:

1. Using a draft gauge (inclined manometer), measure the static pressure of the return duct at the inlet of the unit, (Negative Pressure).

**NOTE:** If an air filter is installed, measure the static pressure between an air filter and air handler.

2. Measure the static pressure of the supply duct, (Positive Pressure).

3. Add the two (2) readings together for total absolute value of external static pressure (for example,  $|-0.30 \text{ inH}_2\text{O}| + |0.20 \text{ inH}_2\text{O}| = 0.50 \text{ inH}_2\text{O}$  ( $|-74.7 \text{ Pa}| + |49.8 \text{ Pa}| = 124.5 \text{ Pa}$ ) total static pressure).

**NOTE:** Both readings may be taken simultaneously and read directly on the manometer if so desired.

4. Consult proper table for quantity of air.

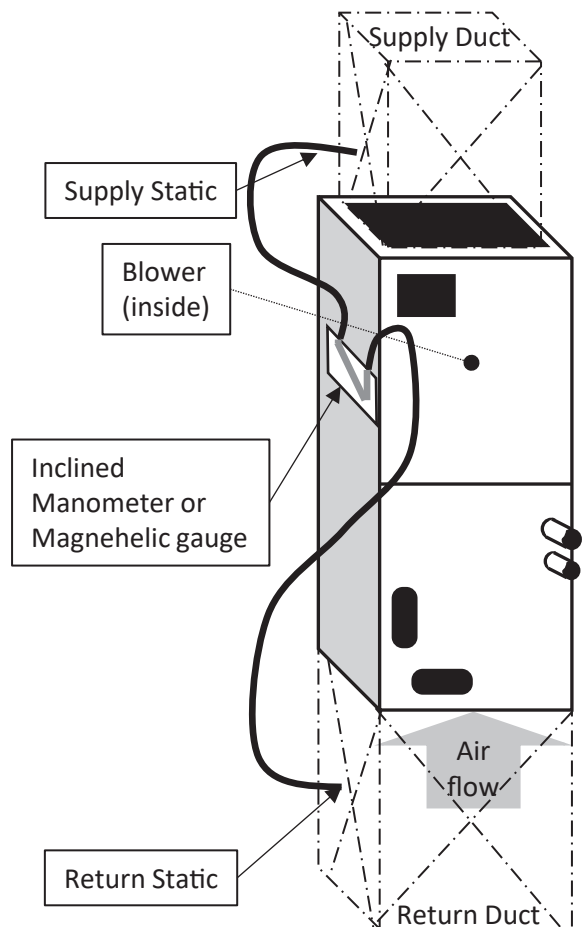

**TOTAL EXTERNAL STATIC**

# SERVICING

## S-203A TWO PIECE INDOOR UNIT EXTERNAL STATIC

Two piece indoor unit refers to EEV cased coil with Gas Furnace/Modular Blower.

To determine proper air movement, proceed as follows:

1. With clean filters in the indoor unit, use a draft gauge (inclined Manometer or Magnehelic gauge) to measure the static pressure of the return duct at the inlet of the Gas Furnace or Modular Blower, this will be a negative pressure (for example,  $-0.30 \text{ inH}_2\text{O}$  ( $-74.7 \text{ Pa}$ )).

**NOTE:** If an air filter is installed with gas furnace, measure the static pressure between an air filter and gas furnace.

2. Measure the static pressure of the supply duct at the outlet of the Gas Furnace or Modular Blower, this should be a positive pressure (for example,  $0.20 \text{ inH}_2\text{O}$  ( $49.8 \text{ Pa}$ )).

3. Add the two (2) readings together for total absolute value of external static pressure (for example,  $|-0.30 \text{ inH}_2\text{O}| + |0.20 \text{ inH}_2\text{O}| = 0.50 \text{ inH}_2\text{O}$  ( $|-74.7 \text{ Pa}| + |49.8 \text{ Pa}| = 124.5 \text{ Pa}$ ) total static pressure).

**NOTE:** Both readings may be taken simultaneously and read directly on the manometer if so desired.

If an Electronic Air Cleaner is used in conjunction with the indoor unit, the readings must also include these components.

4. Consult proper Gas Furnace or Modular Blower airflow chart for quantity of air (CFM) at the measured external static pressure.

If the total external static pressure exceeds the minimum or maximum allowable statics, check for closed dampers, registers, undersized and/or oversized poorly laid out duct work.

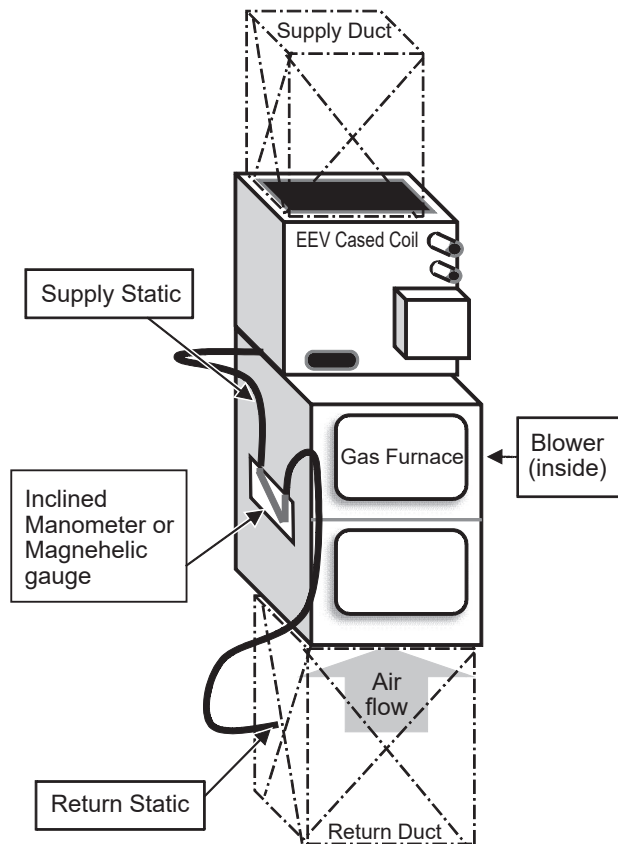

In Case of EEV Cased Coil + Gas Furnace

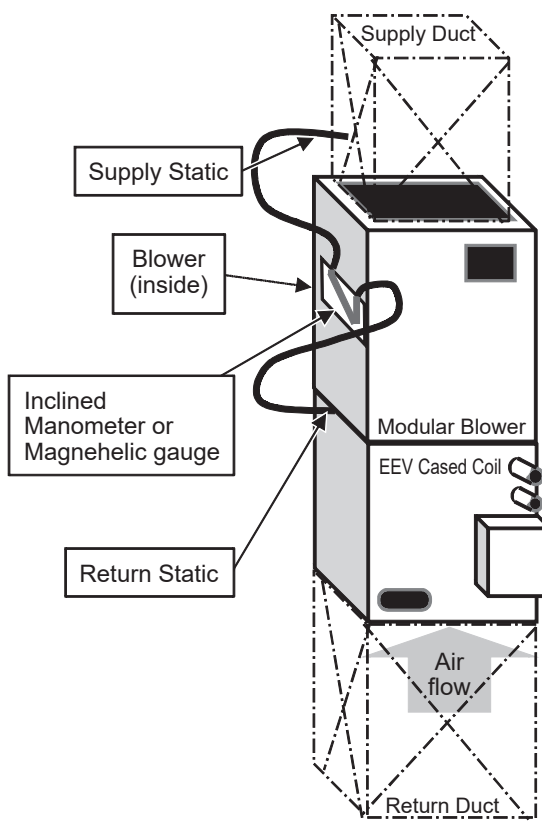

In Case of EEV Cased Coil + Modular Blower

# SERVICING

## CHECKING LEAK DETECTION OUTPUT (AIR HANDLER)

This section applies only to optional damper, UV light and ventilator. In case of using multiple dampers, use an optional kit of A2L ACCESSORY / ZONING CONTROL KIT from EWC.

Please refer to Installation manual of “R-32 ACCESSORY AND ZONING CONTROL KIT” for details.

In case of A2L system, damper must be fully opened and accessories that could be a source of ignition must be turned off if refrigerant leak is detected.

The control board of the air handler unit is equipped with three Refrigerant Leak Detection terminals (dry contact), labeled TB11, TB12 and TB13 that are used for the control of optional kits (damper, UV light, ventilator) when refrigerant leak is detected, the error codes being A0, A1 and AF and when “Refrigerant leak test” is activated through thermostat (\*1).

Following the steps below, conduct Refrigerant Leak Test to check that damper and/or UV light are installed properly.

\*1) When a refrigerant leak is detected, make sure that the damper is fully opened and the circuit is designed to shut down any equipment that could be a source of ignition.

1. Turn on power to the indoor unit
2. Be sure that there is no error code displayed on 7-segment display. If any error codes are shown on 7-segement display, refer to Troubleshooting section.
- 3-1. Using continuity mode on a multimeter, check the electrical connection across TB11 and TB12 AND TB11 and TB13.
- 3-2. Continuity across TB11 and TB12 AND no continuity across TB11 and TB13 indicate normal condition. The conditions other than that, indicate faulty PCB. Replace it as needed. Refer to the table for terminals' outputs.
- 4-1. Using Refrigerant Leak Test through GOODMAN GTST CONNECTED Thermostat and continuity mode on a multimeter, check the electrical connection across TB11 and TB12 AND TB11 and TB13. Refer to the following section, [How start Refrigerant Leak Test].
- 4-2. No continuity across TB11 and TB12 AND continuity across TB11 and TB13 indicate normal condition. The conditions other than that, indicate faulty PCB. Replace it as needed. Refer to the table for terminals' outputs.

Items	When A0/A1/AF not issued	When A0/A1/AF issued and/or “Refrigerant Leak Test” is activated
TB11-TB12 (NC)	CLOSE	OPEN
TB11-TB13 (NO)	OPEN	CLOSE



Leak Detect Output

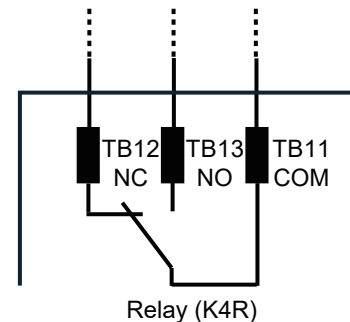

[How start Refrigerant Leak Test]

1. Turn on power to the indoor unit.
2. Go to “Refrigerant Leak Detection” menu under “4 System Optimization” on the thermostat’s commissioning menu.
3. Switch “Refrigerant leak test” setting to “Run test” to start the refrigerant leak test (\*).

(\*) The following actions are activated: the blower runs, electric heater is switched off, the zoning damper fully opens, and the UV light is switched off. After confirming these actions, change the “Refrigerant leak test” setting to “Stop” to finish the test.

**NOTE:** The refrigerant leak test is automatically turn off after 1 hour, even if you do not set it to “stop”.

# SERVICING

## FAULT RECALL (EEV INDOOR UNITS)

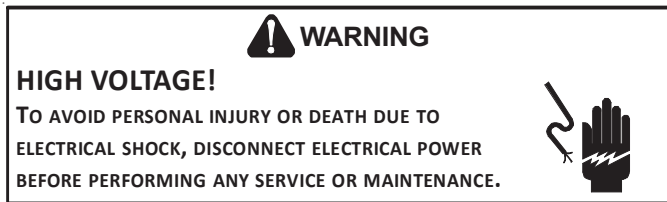

The integrated control module is equipped with a momentary push-button switch that can be used to display the last six faults on the 7 segment LED display. To display the faults, follow the steps below.

**NOTE:** The integrated control module must be in Standby Mode (no thermostat inputs).

1. Press FAULT RECALL button (for 2 to 5 seconds).  
The 7 segment LED display will show solid "--".

**NOTE:** If FAULT RECALL button is not pressed long enough (for 2 to 5 seconds), the control goes back to Standby Mode.

2. Release the FAULT RECALL button. The 7 segment LED display will show the most recent fault.
3. Subsequent pressing of the FAULT RECALL button will recall a previous fault. At the end of the faults, the 7 segment LED display will show "--" and go back to Standby Mode.

**NOTE:** Consecutively repeated faults are displayed a maximum of three times. If the FAULT RECALL button is left untouched longer than 3 minutes, the control goes back to Standby Mode.

To clear the error code history:

1. Press FAULT RECALL button until the 7 segment LED display blinks "--".
2. Release the FAULT RECALL button. The 7 segment LED display will show "88" and clear the faults.

**NOTE:** If FAULT RECALL button is pressed for longer than 15 seconds, control goes back to Standby Mode.

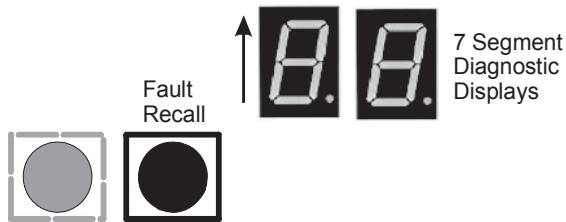

**NOTE:** For the cased coil application, the active error codes displayed on this control board are information related only to EEV cased coil.

The active error codes of gas furnaces and modular blowers are displayed on the control board installed in each unit.

When trouble of the indoor unit occurs, check the active error codes on control board of each unit.

Please refer to the Service Manual of each unit about the Troubleshooting Gas Furnace and Modular Blower.

# SERVICING

## 2-DIGIT 7 SEGMENT DISPLAYS (EEV INDOOR UNITS)



**WARNING**

**HIGH VOLTAGE!**

TO AVOID PERSONAL INJURY OR DEATH DUE TO ELECTRICAL SHOCK, DISCONNECT ELECTRICAL POWER BEFORE PERFORMING ANY SERVICE OR MAINTENANCE.



When the indoor unit is energized power supply, 2-digit 7 segment displays on control board show current status of state and error code.

(※EEV cased coil does not indicate airflow.)

1. State shows current operation status of indoor unit described in right table.

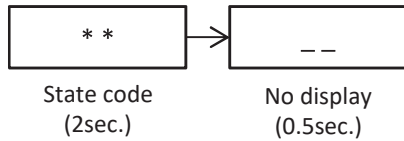

7 Segment LED Display (State)	Description of Condition
(No display)	INTERNAL CONTROL FAULT / NO POWER
On	STANDBY, NORMAL MODE
h1 <sup>(1,2)</sup>	ELECTRIC HEAT STAGE 1 (HEAT PUMP SYSTEM) (EXCLUDING EMERGENCY HEATING)
h2 <sup>(1,2)</sup>	ELECTRIC HEAT STAGE 2 (HEAT PUMP SYSTEM) (EXCLUDING EMERGENCY HEATING)
h3 <sup>(1,2)</sup>	ELECTRIC HEAT STAGE 3 (HEAT PUMP SYSTEM) (EXCLUDING EMERGENCY HEATING)
FC <sup>(1)</sup>	FAN COOL (COMMUNICATING MODE ONLY)
FH <sup>(1)</sup>	FAN HEAT (HEAT PUMP SYSTEM) (COMMUNICATING MODE ONLY)
_F <sup>(1)</sup>	FAN ONLY
H1 <sup>(1,2)</sup>	ELECTRIC HEAT STAGE 1 (AC SYSTEM) (EXCLUDING EMERGENCY HEATING)
H2 <sup>(1,2)</sup>	ELECTRIC HEAT STAGE 2 (AC SYSTEM) (EXCLUDING EMERGENCY HEATING)
H3 <sup>(1,2)</sup>	ELECTRIC HEAT STAGE 3 (AC SYSTEM) (EXCLUDING EMERGENCY HEATING)
dF <sup>(1)</sup>	DEFROST MODE
EE	EMERGENCY MODE
Hu <sup>(1)</sup>	HUMIDIFIER RUNNING WITHOUT HEATING

\*1: EEV cased coil does not indicate.

\*2: 115 V Air Handler does not indicate.

2. Error code shows current error indoor unit has. To see the previous error code, please follow the instruction of fault recall. For more information of error code, please see the table of indoor unit error code.

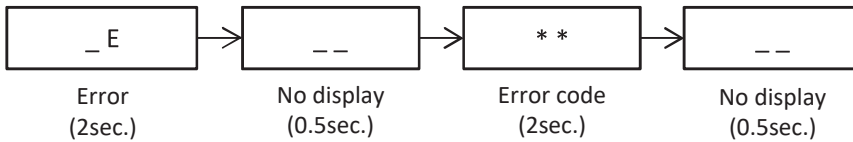

3. Airflow shows estimated CFM of indoor unit. For example, if the CFM is 1240 CFM, 7 segment display shows "A...12...40..."

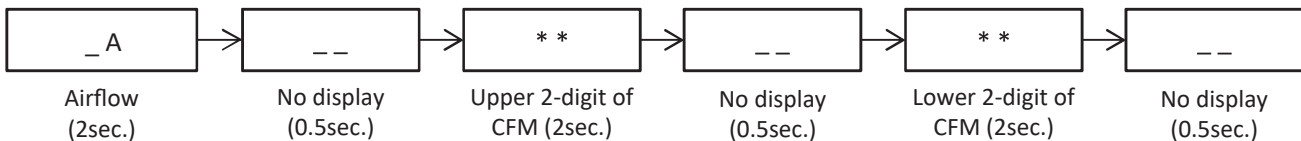

The contents indicated at 7 segment display vary according to operation mode and status of indoor unit. In the event of showing some error code, please follow the instruction in the table of indoor unit error code to solve the error.

1. When the unit is running in normal mode, 2-digit 7 segment displays show state and airflow status.

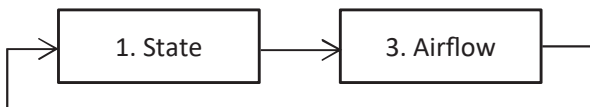

# SERVICING

## 2-DIGIT 7 SEGMENT DISPLAYS (EEV INDOOR UNITS)

- When the unit is having some major and minor error code in standby normal mode, 2-digit 7 segment displays keep showing error code.

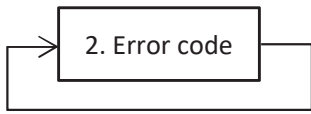

- When the unit is having some minor error code in normal mode, 2-digit 7 segment displays show error code and airflow status.

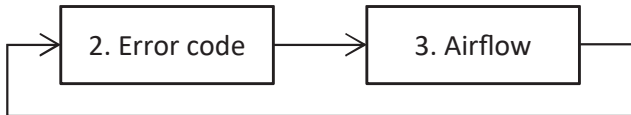

- When the unit is having some minor error code during defrost operation in normal mode, 2-digit 7 segment displays show state "dF," error code and airflow status.



- When the unit is having some minor error code during Emergency mode, 2-digit 7 segment displays show state "EE" and error code.

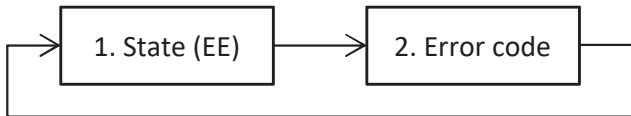

# SERVICING

## SETTING THE MODE DISPLAY (EEV INDOOR UNITS)

### MODE DISPLAY INTRODUCTION

A 2-digit display is provided on the control board as a backup tool to the thermostat for accessing error codes and erasing error code history of the EEV indoor units. Follow the information provided in this section to learn how to use the mode display.

### DISPLAY

The display consists of 2 digits.

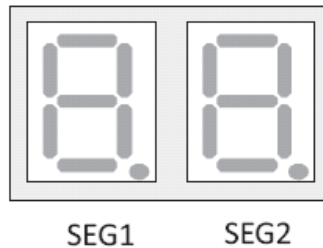

### DISPLAY BUTTON LAYOUT

The display buttons shown can be used to navigate and select items:

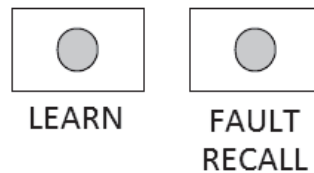

*Example of button layout is shown above*

### ERROR CODE HISTORY NAVIGATION

This mode will allow the user to see the six most recent EEV indoor units faults. Please follow the flowchart to navigate to error codes from screen zero.

For a list of the error codes, please see the TROUBLESHOOTING tables in this document.

It is also possible to erase all the diagnostics codes from this menu.

# SERVICING

## SETTING THE MODE DISPLAY (EEV INDOOR UNITS)

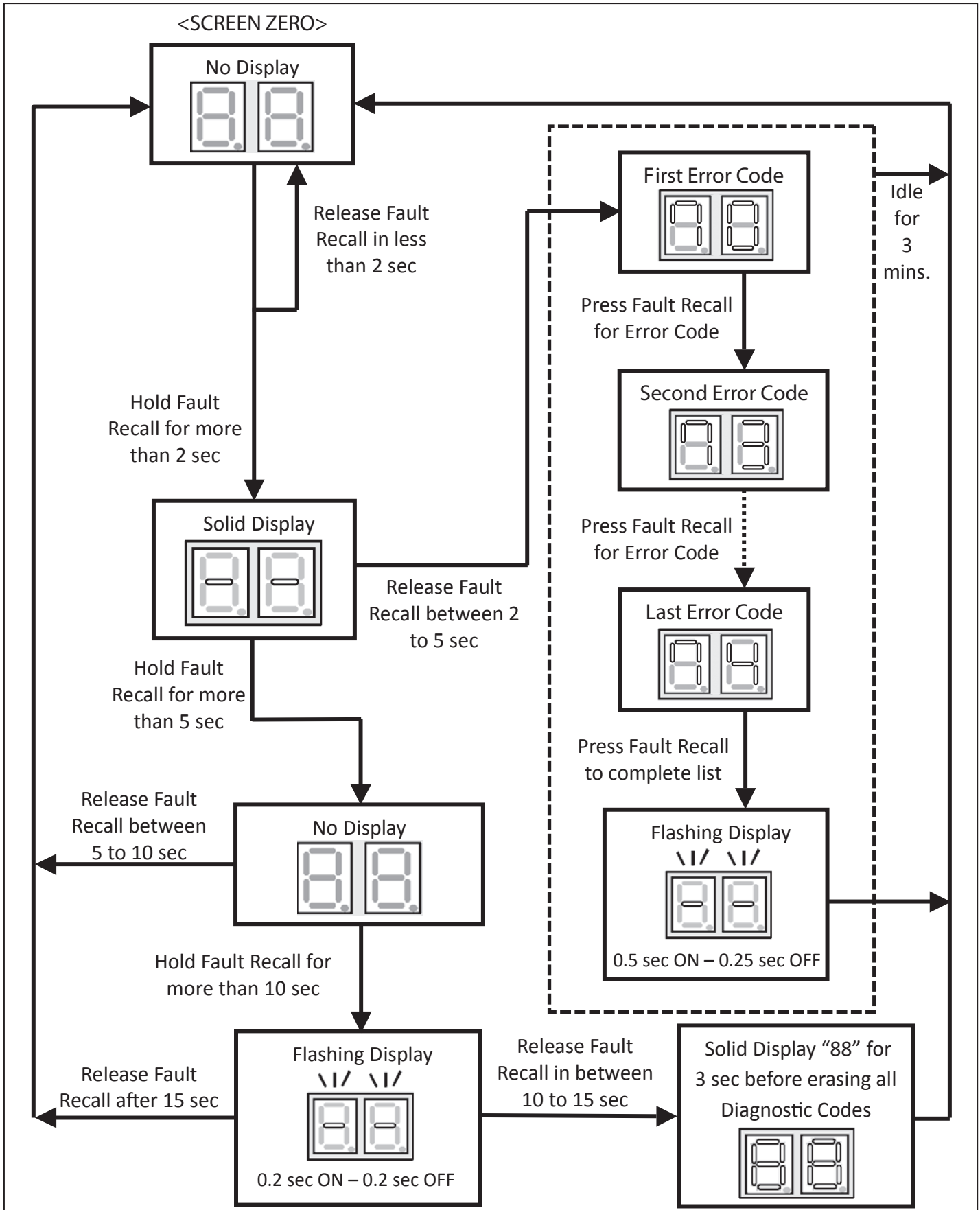

### TROUBLESHOOTING

Error Code	Control board LED Display	Description	Possible Causes	Corrective Actions
EE	No display*1	<ul style="list-style-type: none"> <li>No 24 volt power to control board</li> <li>Blown fuse or circuit breaker</li> <li>Control board has an internal fault</li> </ul>	<ul style="list-style-type: none"> <li>Manual disconnect switch OFF</li> <li>No 24 volt power to control board</li> <li>Blown fuse or faulty circuit breaker</li> <li>Control board has internal fault</li> </ul>	<ul style="list-style-type: none"> <li>Assure 115/208/230 volt and 24 volt power to blower and control board.</li> <li>Check fuse F2U on control board.</li> <li>Check for possible short in 115/208/230 volt and 24 volt circuits. Repair as necessary.</li> <li>Replace the control board.</li> </ul>
Eb	E_Eb	Selecting "no heater kit" and receiving electric heat demand	<ul style="list-style-type: none"> <li>No heater kit selected</li> </ul>	<ul style="list-style-type: none"> <li>Select the valid heater kit on thermostat</li> <li>Valid dip switch selection (heater kit selection out of range of the unit configuration)</li> <li>The operation utilizing the heater kit is configured within the indoor unit even when the heater kit is not physically connected to it. (For example, in a 115 V Air Handler system, the "Defrost Heat" setting of the outdoor unit or "Backup Defrost Heat" setting of the thermostat are set to other than "OFF".)</li> </ul>
Ed	E_Ed	Heater kit dip switches not set properly	<ul style="list-style-type: none"> <li>Invalid heater kit selected</li> </ul>	<ul style="list-style-type: none"> <li>Set correct dip switches</li> </ul>
E5	E_E5	Fuse open	<ul style="list-style-type: none"> <li>Fuse (F1U) is blown</li> <li>Connector TB10 is open</li> </ul>	<ul style="list-style-type: none"> <li>Replace fuse</li> <li>Check wiring to AUX alarm, heater kit, communication connection.</li> <li>Replace the control board</li> </ul>
EF	E_EF	Auxiliary switch open	<ul style="list-style-type: none"> <li>High water level in the evaporation coil</li> <li>The connected alarm device is activated</li> <li>Auxiliary alarm terminals (TB4, TB5) are open</li> </ul>	<ul style="list-style-type: none"> <li>Check water level in drain pan</li> <li>Check alarm device.</li> <li>Close auxiliary terminals TB4 and TB5 if not used</li> </ul>
d0	E_d0	Data not on network	<ul style="list-style-type: none"> <li>No shared data on the network</li> </ul>	<ul style="list-style-type: none"> <li>Populate shared data set using memory card.</li> </ul>
d1	E_d1	Invalid data on network	<ul style="list-style-type: none"> <li>Wrong shared data on the network</li> </ul>	<ul style="list-style-type: none"> <li>Populate shared data set using memory card.</li> </ul>
d4	E_d4	Invalid memory card data	<ul style="list-style-type: none"> <li>Wrong memory card data</li> </ul>	<ul style="list-style-type: none"> <li>Replace control board</li> <li>Rewrite data using the correct memory card</li> </ul>
b0	E_b0	Blower motor not running	<ul style="list-style-type: none"> <li>Fan/motor obstruction</li> <li>Power interruption (low voltage)</li> <li>Incorrect/loose wiring</li> </ul>	<ul style="list-style-type: none"> <li>Check for obstruction on the fan/motor</li> <li>Verify the input voltage at the motor</li> <li>Check wiring or tighten wiring connections if needed</li> <li>Replace control board or motor</li> </ul>
b1	E_b1	Blower motor communication error	<ul style="list-style-type: none"> <li>Incorrect/loose wiring</li> <li>Power interruption (low voltage)</li> </ul>	<ul style="list-style-type: none"> <li>Check wiring or tighten wiring connections if needed</li> <li>Verify the input voltage at the motor</li> <li>Replace control board or motor</li> </ul>
b2	E_b2	Blower motor HP mismatch	<ul style="list-style-type: none"> <li>Incorrect size motor</li> <li>Invalid shared data</li> </ul>	<ul style="list-style-type: none"> <li>Correct motor installation</li> <li>Populate shared data set using memory card.</li> </ul>
b3	E_b3	Blower motor operating in power, Temp or speed limiting conditions	<ul style="list-style-type: none"> <li>Fan/motor obstruction or blocked filters</li> <li>Power interruption (low voltage)</li> <li>Incorrect wiring</li> <li>Blockage in the airflow (ductwork) or ductwork undersized</li> </ul>	<ul style="list-style-type: none"> <li>Check for obstruction on the fan/motor/ductwork, clean filters</li> <li>Verify the input voltage at the motor</li> <li>Check wiring</li> <li>Replace motor</li> </ul>

\*1: When "EE" is displayed on the LED display, it indicates the state of Emergency mode.

### TROUBLESHOOTING

Error Code	Control Board LED Display	Description	Possible Causes	Corrective Actions
b9	E_b9	Low indoor airflow (without electric heat mode)	<ul style="list-style-type: none"> <li>Fan/motor obstruction or blocked filters</li> <li>Restrictive ductwork or ductwork undersized</li> <li>ID motor failure</li> </ul>	<ul style="list-style-type: none"> <li>Check for obstruction on the fan/motor</li> <li>Check ductwork/filter for blockage, clean filters</li> <li>Remove obstruction. Verify all registers are fully open</li> <li>Check the connections and the rotation of the motor</li> <li>Verify the input voltage at the motor</li> <li>Verify ductwork is appropriately sized for system. Resize/replace ductwork if needed</li> <li>Replace motor</li> </ul>
9b	E_9b	Low indoor airflow (with electric heat mode)	<ul style="list-style-type: none"> <li>Fan/motor obstruction or blocked filters</li> <li>Restrictive ductwork or ductwork undersized</li> <li>ID motor failure</li> <li>Combination mistake of outdoor unit and indoor unit</li> </ul>	<ul style="list-style-type: none"> <li>Check for obstruction on the fan/motor</li> <li>Check ductwork/filter for blockage, clean filters</li> <li>Remove obstruction. Verify all registers are fully open</li> <li>Check the connections and the rotation of the motor</li> <li>Verify the input voltage at the motor</li> <li>Verify ductwork is appropriately sized for system. Resize/replace ductwork if needed</li> <li>Replace motor</li> </ul>
70	E_70	EEV disconnection detected	<ul style="list-style-type: none"> <li>Indoor EEV coil not connected</li> <li>Incorrect wiring to EEV</li> </ul>	<ul style="list-style-type: none"> <li>Check indoor EEV coil connection (control board and junction connector)</li> <li>Replace EEV coil</li> <li>Check the resistance value of EEV coil</li> <li>Replace the control board</li> </ul>
73	E_73	Liquid side thermistor abnormality	<ul style="list-style-type: none"> <li>Open or short circuit of the liquid thermistor (X5A)</li> <li>Liquid thermistor reading incorrect or values outside the normal range</li> </ul>	<ul style="list-style-type: none"> <li>Check the connection to liquid thermistor (control board and junction connector)</li> <li>Check the resistance value of the thermistor</li> <li>Replace thermistor</li> <li>Replace the control board</li> </ul>
74	E_74	Gas side thermistor abnormality	<ul style="list-style-type: none"> <li>Open or short circuit of the gas thermistor (X5A)</li> <li>Gas thermistor reading incorrect or values outside the normal range</li> </ul>	<ul style="list-style-type: none"> <li>Check the connection to gas thermistor (control board and junction connector)</li> <li>Check the resistance value of the thermistor</li> <li>Replace thermistor</li> <li>Replace the control board</li> </ul>
75	E_75	Pressure sensor abnormality	<ul style="list-style-type: none"> <li>Open or short circuit of the pressure sensor (X15A)</li> <li>Pressure sensor reading incorrect or values outside the normal range</li> </ul>	<ul style="list-style-type: none"> <li>Check the connection to pressure sensor (control board and junction connector)</li> <li>Check the output voltage of the pressure sensor</li> <li>Replace pressure sensor</li> <li>Replace the control board</li> </ul>
76 <sup>*2</sup>	E_76	Indoor unit - outdoor unit, gas furnace or blower unit communication error (during operation)	<ul style="list-style-type: none"> <li>Open communication circuit</li> <li>Incorrect wiring between OD unit, gas furnace or modular blower</li> <li>No power supply to OD unit, gas furnace or modular blower</li> </ul>	<ul style="list-style-type: none"> <li>Check for indoor unit and other unit wiring.</li> <li>Replace the control board</li> <li>Check power supply to OD unit, gas furnace or modular blower</li> </ul>
77 <sup>*2</sup>	E_77	Indoor unit - thermostat communication error (start-up & during operation)	<ul style="list-style-type: none"> <li>Incorrect wiring between ID unit and thermostat. The system may have the communication error without error code 77 on the indoor unit control board.</li> <li>Thermostat failure</li> <li>Power interruption (low voltage)</li> </ul>	<ul style="list-style-type: none"> <li>Check for thermostat and indoor unit wiring</li> <li>Verify the input voltage at the ID unit and thermostat</li> <li>Replace the control board or thermostat</li> <li>Press "LEARN" button on control board for more than 5 seconds to reestablish network</li> </ul>
78 <sup>*2</sup>	E_78	Indoor unit - outdoor unit, gas furnace or blower unit communication error (startup operation)	<ul style="list-style-type: none"> <li>Open communication circuit</li> <li>Incorrect wiring between OD unit, gas furnace or modular blower</li> <li>No power supply to OD unit, gas furnace or modular blower</li> </ul>	<ul style="list-style-type: none"> <li>Check for indoor unit and other unit wiring.</li> <li>Replace the control board</li> <li>Check power supply to OD unit, gas furnace or modular blower</li> </ul>
A0	E_A0	A2L Refrigerant Leak Error (*1)	<ul style="list-style-type: none"> <li>Refrigerant Leak</li> <li>A2L sensor failure</li> </ul>	<ul style="list-style-type: none"> <li>Ventilate the room before conducting any actions</li> <li>Check tubing and coil leakage</li> <li>Remove refrigerant from system and replace coil</li> </ul>
A1	E_A1	A2L Sensor Internal Error (*1)	<ul style="list-style-type: none"> <li>A2L sensor failure</li> </ul>	<ul style="list-style-type: none"> <li>Replace A2L sensor</li> <li>Replace control board</li> </ul>
AF	E_AF	A2L Sensor Communication Error (*1)	<ul style="list-style-type: none"> <li>A2L sensor not connected</li> <li>Incorrect wiring of A2L sensor</li> </ul>	<ul style="list-style-type: none"> <li>Check the connection of A2L sensor</li> <li>Replace A2L sensor</li> <li>Replace control board</li> </ul>

(\*1) The following actions are conducted when the error code A0, A1 or AF is issued:

• Fan running for mitigating leaked refrigerant

• Leak Detection Output (Relay: K4R) energized (Refer to CHECKING LEAK DETECTION OUTPUT (AIR HANDLER).)

Refer to gas furnace's installation & operating instructions and/or service manual for operation of A2L compatible gas furnace system

\*2: Network communication error (Refer to "NETWORK TROUBLESHOOTING")

**Note:** Heater kits cannot be connected to Air Handler with 115 V specifications. If an error related to the heater kit is displayed, please check whether any functions using the heater kit are configured. Kindly disable all the heater kit functions for these models.

# SERVICING

## EMERGENCY MODE FOR EEV APPLICABLE INDOOR UNIT

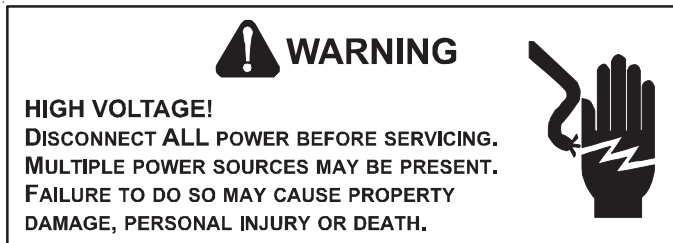

Emergency mode is to only be used in a situation where communication between equipment (broken wires) or a failed thermostat cannot be immediately corrected or replaced. This mode will allow for cooling or heating to be activated without the need of communication wires or a thermostat. Once corrections have been made to wiring or the thermostat, emergency mode must be turned off and the system returned to normal operation (this applies to both the indoor and outdoor units). **NOTE:** Emergency mode does not control to a specific room temperature set point. Exact room temperature achieved is related to the building load at the time emergency mode is activated. This is only a temporary solution.

At first inspection, if the outdoor unit is displaying one of the following error codes: E51 (outdoor communication error) or the EEV indoor unit is displaying one of the following error codes: E76 (no outdoor unit or indoor unit communications), E77 (no thermostat communications), E78 (no outdoor unit or indoor unit communications), it is acceptable to use emergency mode if the equipment cannot be immediately fixed. Cycling power to the equipment may temporarily clear error codes but doing so may not fix the underlying problem. **NOTE:** If after initial power up communication issues occur due to faulty wires or a thermostat these error codes may not be displayed.

In emergency mode, the unit will operate according to the mode selected on the appropriate dip switches. Operation in emergency mode must be limited to a minimum and should be viewed as a temporary solution before the issue with the unit is resolved and system operates in normal mode.

**NOTE:** In the emergency operation, the operating status will not be shown in the thermostat status menu or on the outdoor 7-segment displays. The 7-segment displays on the EEV indoor unit control board will display "EE".

## 1. HEATING EMERGENCY MODE

Emergency Heating Mode is to be used when communication between each equipment is not functioning properly.

There are the following steps to setup Heating Emergency Mode.



### FOR EEV CASED COIL

This mode uses Gas Furnace or Modular Blower (electric heater).

- 1) Remove the thermostat communication wirings (1, 2, R and C) of all connected equipment (EEV cased coil, Gas Furnace/Modular Blower, Outdoor unit and thermostat) from the communication terminals. Communication terminals are on control board inside each equipment.

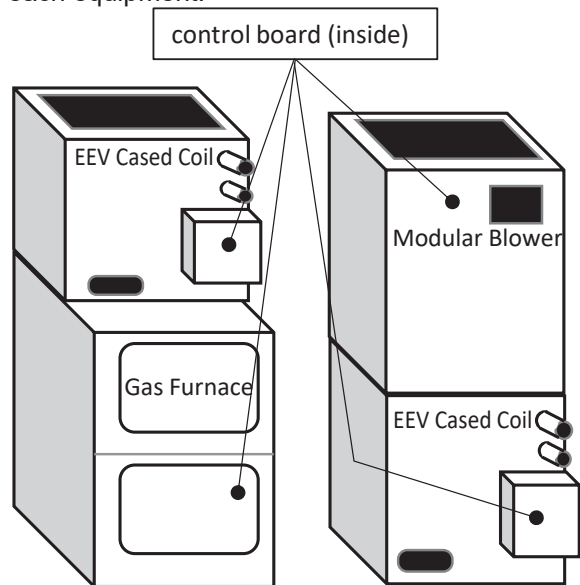

Case of EEV Cased Coil+Gas Furnace      Case of EEV Cased Coil+Modular Blower

- 2) Reconnect the wirings to the communication terminal of the Gas Furnace or Modular Blower. (Short-circuit the communication terminal with wirings.) Connect the wiring so that the Gas Furnace or Modular Blower alone operates in the Heating Emergency Mode without using the Thermostat. Refer to the service manual of the Gas Furnace or Modular Blower for wiring connection points in the Heating Emergency Mode.
- 3) Set the EEV cased coil to Heating Emergency Mode. (Set dip switches S-21 to OFF and S-22 to ON of switch bank DS-6 on the EEV cased coil control board.)
- 4) Operation starts in Heating Emergency Mode when the power of the equipment is turned on. (It is not necessary to set the Heating Emergency Mode with the dip switch in the outdoor unit.)

**NOTE:** During the Heating Emergency Mode, outdoor unit must stop operation. When proper communication is established, these settings must be restored to default. You must also restore the thermostat communication wirings of all the equipment.

# SERVICING

## FOR EEV AIR HANDLER

This mode will run the electric heat strips independently of any thermostat in one of two modes: High Heat Level or Low Heat Level.

- 1) Dip Switch Bank DS-6 (specifically dipswitches S-21 and S-22) on the indoor unit control board is used to engage emergency heating mode. Default setting for these two dip switches are in the OFF position (S21 set to ON and S22 set to ON will enable Low Heat Level Emergency Mode. S21 set to OFF and S22 set to ON will enable High Heat Level Emergency Mode). Note: once equipment has been fixed, these dip switches must be placed back in the OFF position. During operation, the indoor fan and electric heater kit will be turned on and off at following intervals based on the Heat Level selected. 2 stage electric heater kits will be energized in stage 2. 3 stage electric heater kits will be energized in stage 3.

	Heating On	Heating Off
High Heat Level	8 minutes	8 minutes
Low Heat Level	7 minutes	15 minutes

- 2) Emergency Heat Mode Airflow: DIP switches S-9, S-10, S-11 and S-12 must be set to the correct size electric heater kit that has been installed. These are located on dip switch bank DS-3 of the indoor unit control board. See the switch bank DS-3 indoor unit control board settings table to properly select heater kit size.

**NOTE:** During the heating emergency mode, outdoor unit must stop operation. Once the communication is established, heating emergency mode must be terminated so that the system resumes operation in normal mode. To eliminate the heating emergency mode, dip switches S-21 and S-22 from dip switch bank DS-6 on the indoor unit control board must be set back to default factory settings (normal operating mode).

**NOTE:** Upon start up in emergency mode the control board may display an “Ed” error. This is an indication that the DIP switches on the control board need to be configured in accordance with the Electric Heating Airflow Table. Configuring the DIP switches to the unit will clear the error code.

**NOTE:** The 115 V Air Handler does not have a heater kit, so this model is not supported.

## 2. COOLING EMERGENCY MODE

Cooling Emergency Mode is to be used when communication between the indoor and outdoor units is not functioning properly and temporary cooling operation is required. This mode enables the outdoor unit and indoor unit to run independently of each other. There are the following steps to setup Cooling Emergency Mode.

The compressor speed will automatically adjust based on the outdoor ambient temperature.

If ambient temperature is higher than 95°F, the outdoor unit can operate at 100% compressor speed.

If ambient temperature is lower than 70°F, the unit will run at 50% compressor speed.

Between 95°F and 70°F, the compressor speed will adjust linearly as shown.

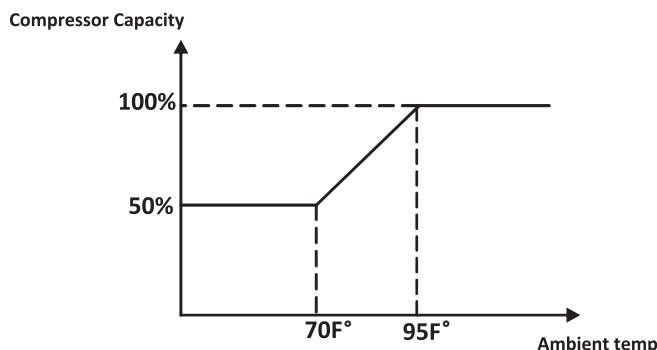

During operation the indoor unit will provide constant airflow as selected (even if the compressor has stopped). The indoor unit will continue to operate the electronic expansion valve for refrigerant superheat control and the compressor will cycle at the specific interval.



### WARNING

WHEN SETTING AND WIRING, BE SURE TO TURN OFF THE POWER OF EQUIPMENT.

# SERVICING

## For EEV CASED COIL

There are the following steps to setup Cooling Emergency Mode.

- 1) Remove the thermostat communication wirings (1, 2, R and C) of all connected equipment (EEV cased coil, Gas Furnace/Modular Blower, Outdoor unit and thermostat) from the communication terminals. Communication terminals are on control board inside each equipment.
- 2) Reconnect the wirings to the communication terminal of the Gas Furnace or Modular Blower. (Short-circuit the communication terminal with wirings.) Connect the wiring so that the Gas Furnace or Modular Blower alone operates in the Cooling Emergency Mode without using the Thermostat. Refer to the service manual of the Gas Furnace or Modular Blower for wiring connection points in the Cooling Emergency Mode.
- 3) Set the EEV cased coil to Cooling Emergency Mode. (Set dip switches S-21 to ON and S-22 to OFF of switch bank DS-6 on Cased Coil control board.)
- 4) Select the desired cooling level at the outdoor unit (there are 3 levels available: Low Cool Level, Medium Cool Level, High Cool Level selectable by dip switch bank DS-2 on the outdoor unit). See Dip Switch Position S-1 and S-2 Table for cooling level selection.
- 5) Operation starts in Cooling Emergency Mode when the power of the equipment is turned on.

**NOTE:** Reconnect the Emergency cooling mode wirings to the communication terminal of Gas Furnace or Modular Blower before setting outdoor DS-2 dip switch settings. Otherwise, the compressor may be damaged in operation.

**NOTE:** When proper communication is established, these switches must be restored to default. You must also restore the thermostat communication wirings of all the equipment.

## For EEV AIR HANDLER

There are two key steps to setup Cooling Emergency Mode.

- 1) Select the appropriate airflow on the indoor unit and enable emergency indoor airflow operation (using Dip switches S-13 and S-14 of Switch Bank DS-4 on the indoor unit to select desired 25%, 50%, 75% or 100% airflow. In addition, set switch bank DS-6 dip switches S-21 to ON and S-22 to OFF enabling emergency indoor fan).
- 2) Select the desired cooling level at the outdoor unit (there are 3 levels available: Low Cool Level, Medium Cool Level, High Cool Level selectable by dip switch bank DS-2 on the outdoor unit). See Dip Switch Position DS2-1 and DS2-2 Table for cooling level selection.

**NOTE:** When proper communication is established, these switches must be returned to default settings

Switch Bank DS-3 EEV Air Handler Control Board Settings									
EEV Air Handler Nominal Capacity  Heater Kit Selection	Heater kW					Dip Switch Setting			
	24	35, 36	42	47, 48	59, 60	S-9	S-10	S-11	S-12
No Heater	-	-	-	-	-	OFF*	OFF*	OFF*	OFF*
First	3	3/5	3/5	3/5	3/5	ON	ON	ON	ON
Second	5	6	6	6	6	ON	ON	ON	OFF
Third	6	8	8	8	8	ON	ON	OFF	ON
Fourth	8	10	10	10	10	ON	ON	OFF	OFF
Fifth	10	15	15	15	15	ON	OFF	ON	ON
Sixth		19	19	20	20	ON	OFF	ON	OFF
Seventh					25	ON	OFF	OFF	ON

**NOTE:** Default factory settings are marked with \*.

**NOTE:** Not applicable for 115 V Air Handler. (All dip switches should be "OFF".)

# SERVICING

Switch Bank DS-4 EEV Air Handler Fan Settings			
Function	Value	S-13	S-14
Fan Only Speed	25%	OFF	OFF
	50%	ON*	OFF*
	75%	OFF	ON
	100%	ON	ON

Switch Bank DS-6 EEV Air Handler and Cased Coil Control Board Settings			
Function		S-21	S-22
Normal operation		OFF*	OFF*
Emergency Mode	Cooling Emergency mode	ON	OFF
	Heating Emergency mode (High) *2	OFF	ON
	Heating Emergency mode (Low) *1 *2	ON	ON

\*1. EEV Cased Coil does not have this function.

\*2. 115 V Air Handler does not have this function.

Switch Bank DS-2 Outdoor Unit Control Board Settings			
Function		S-1	S-2
Normal operation		OFF*	OFF*
Emergency Mode	Cooling Emergency mode (Low)	ON	OFF
	Cooling Emergency mode (Medium)	OFF	ON
	Cooling Emergency mode (High)	ON	ON

**NOTE:** Default factory settings are marked with \*.

Dip Switch Default Factory Settings			
Switch #	Setting	Function	
Indoor unit DS-1	1	OFF	No Use
	2	OFF	No Use
	3	OFF	No Use
	4	OFF	No Use
Indoor unit DS-2	5	OFF	No Use
	6	OFF	No Use
	7	OFF	No Use
	8	OFF	No Use
Indoor unit DS-3	9	OFF	Heater Kit Selection in Emergency Mode (Only for EEV Air Handler)***
	10	OFF	Heater Kit Selection in Emergency Mode (Only for EEV Air Handler)***
	11	OFF	Heater Kit Selection in Emergency Mode (Only for EEV Air Handler)***
	12	OFF	Heater Kit Selection in Emergency Mode (Only for EEV Air Handler)***
Indoor unit DS-4	13	ON	Allow in Emergency Mode [Fan Emergency Mode] (Only for EEV Air Handler)*
	14	OFF	Allow in Emergency Mode [Fan Emergency Mode] (Only for EEV Air Handler)*
	15	ON	EEV Enable**
	16	OFF	No Use
Indoor unit DS-5	17	OFF	No Use
	18	OFF	No Use
	19	OFF	No Use
	20	OFF	No Use
Indoor unit DS-6	21	OFF	Emergency mode (Cooling & Heating Emergency Mode)*
	22	OFF	Emergency mode (Cooling & Heating Emergency Mode)*
	23	OFF	No Use
	24	OFF	No Use
Indoor unit DS-7	1	ON	Termination resistance (refer to [NETWORK TROUBLESHOOTING])
	2	ON	Termination resistance (refer to [NETWORK TROUBLESHOOTING])
Outdoor unit DS-1	1	ON	Termination Resistor
	2	ON	Termination Resistor
Outdoor unit DS-2	1	OFF	Cooling Emergency mode*
	2	OFF	Cooling Emergency mode*

\* Must be set at factory setting to operate the normal mode.

\*\* Must be set at factory setting in indoor unit with EEV. It's prohibited to change setting.

\*\*\* 115 V Air Handler does not have this function.

# SETTING THE MODE DISPLAY

## MODE DISPLAY INTRODUCTION

A 3-digit display is provided on the control board as a backup tool to the thermostat for reading faults, error code history, monitoring and setting up the outdoor unit. Follow the information provided in this section to learn how to use the mode display.

## DISPLAY

The display consists of 3 digits.

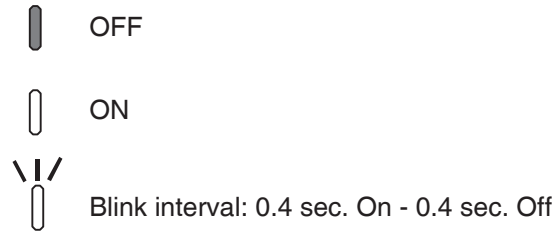
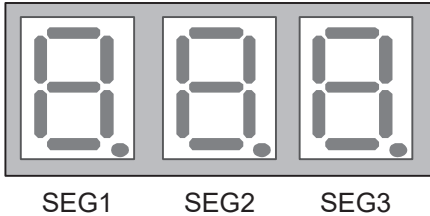

## DISPLAY BUTTON LAYOUT

The display buttons shown can be used to navigate and select items:

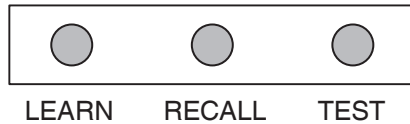

## MODES

There are 5 modes which can be accessed using the setting display:  
Error code display, Error code history, Monitoring mode, Setting mode 1, Setting mode 2.

To enter any of these modes, use the schemes shown in this section. Each mode has its own corresponding "Screen #" within the display itself which allows the user to navigate and use the features. (Example: The Error code display is accessed and displayed from "Screen Zero" of the 7-segment display. The Error code history is accessed and displayed using "Screen One" of the display, etc.)

<b><u>MODE</u></b>	<b><u>FUNCTION</u></b>	<b><u>DISPLAY SCREEN #</u></b>
<i>Error code display</i>	Present fault (if any).	0 (Default)
<i>Error code history</i>	6 Recent faults stored.	1
<i>Monitoring mode</i>	*Monitors system values.	2
<i>Setting mode 1</i>	*Can change system settings	3
<i>Setting mode 2</i>	*Can change system settings.	4

*\*See tables at the end of this section.*

# SETTING THE MODE DISPLAY

## NAVIGATING THROUGH THE DISPLAY SCREENS

- SCREEN 0** The home or default screen on the display. This shows the most recent fault.
- SCREEN 1** To access, hold the "RECALL" button from screen 0 - 5 seconds.
- SCREEN 2** To access, hold the "RECALL" button from screen 1 - 5 seconds.
- SCREEN 3** To access, hold the "RECALL" button from screen 2 - 5 seconds.
- SCREEN 4** To access, hold the "RECALL" and "TEST" buttons simultaneously - 5 seconds.

To return to SCREEN 0 of the display, press the LEARN button.

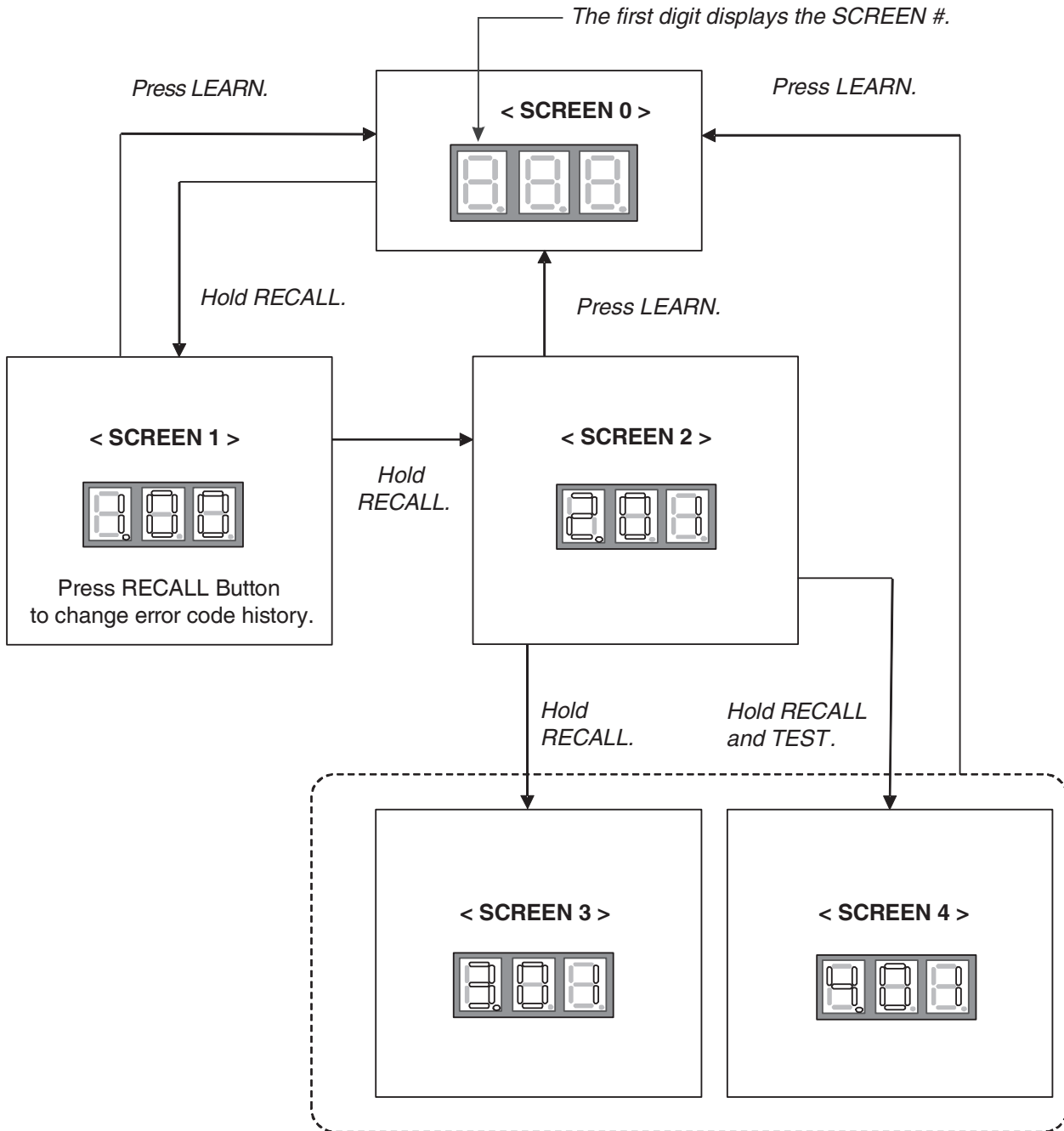

# SETTING THE MODE DISPLAY

## ERROR CODE HISTORY NAVIGATION

### < SCREEN 1 >

This mode will allow the user to see the six most recent system faults.  
For a list of the error codes, please see the TROUBLESHOOTING tables in this document.

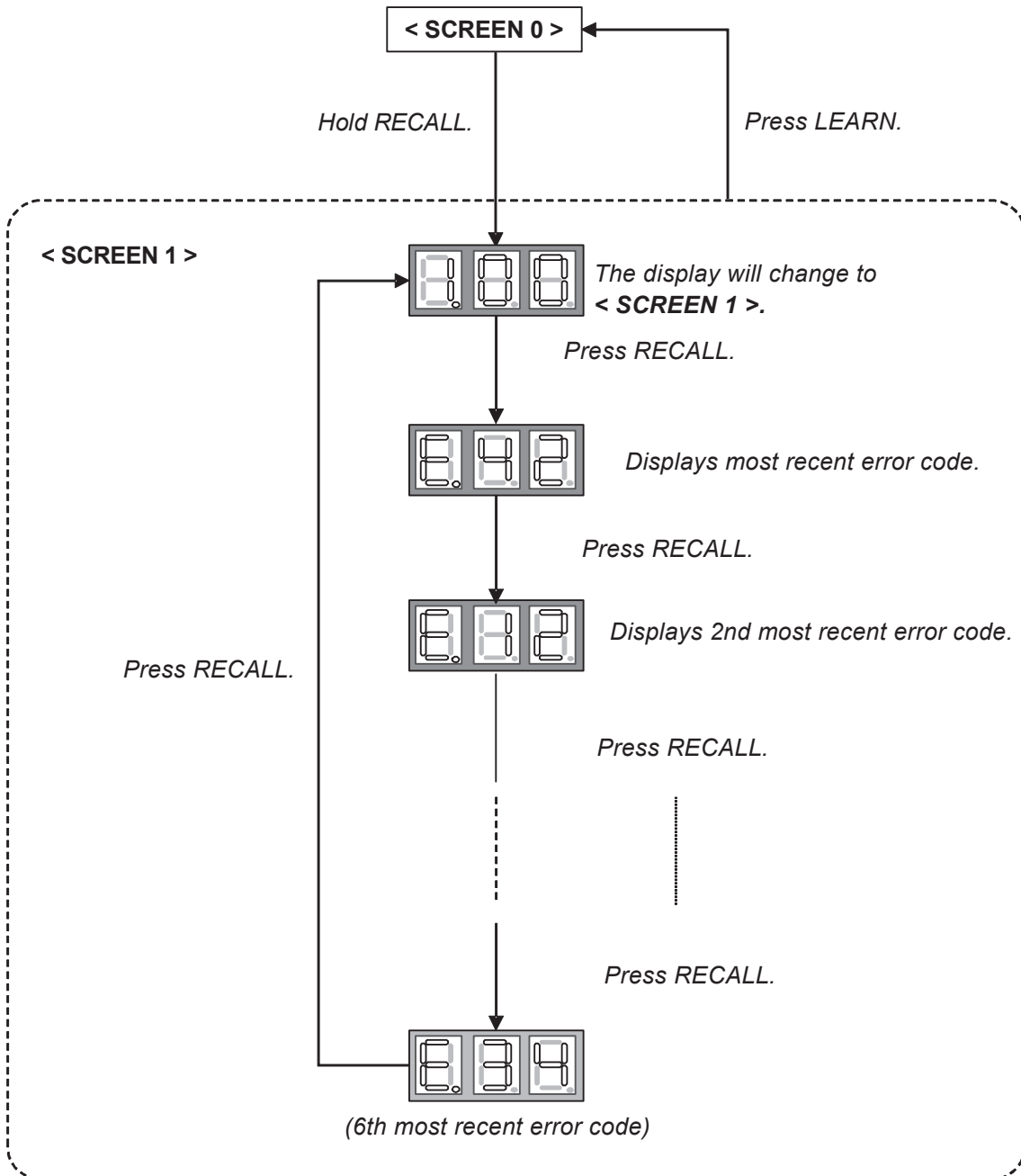



# SETTING THE MODE DISPLAY

## SETTINGS MODE 1 NAVIGATION

< SCREEN 3 >

Setting Mode 1 allows the user to adjust system settings as shown in the tables at the end of this section.

< SCREEN 0 >

OFF

ON



Blink interval:  
0.4 sec. On - 0.4 sec. Off

< SCREEN 2 >

Hold RECALL.

Press LEARN.

< SCREEN 3 >

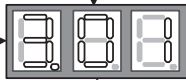

Press RECALL  
to increase the value.

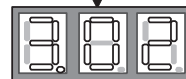

Press RECALL.

Press  
RECALL.

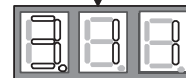

Press RECALL.

Press TEST  
to change setting.

Press RECALL.

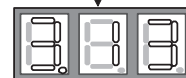

< Changing Setting Display >

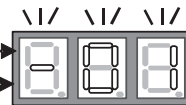

Press RECALL  
to increase the value.

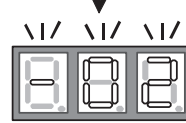

Press TEST.

Press  
RECALL.

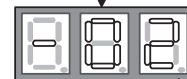

Press RECALL.

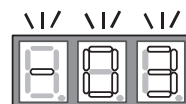

Press RECALL.

Press TEST to complete setting and return to setting mode.

# SETTING THE MODE DISPLAY

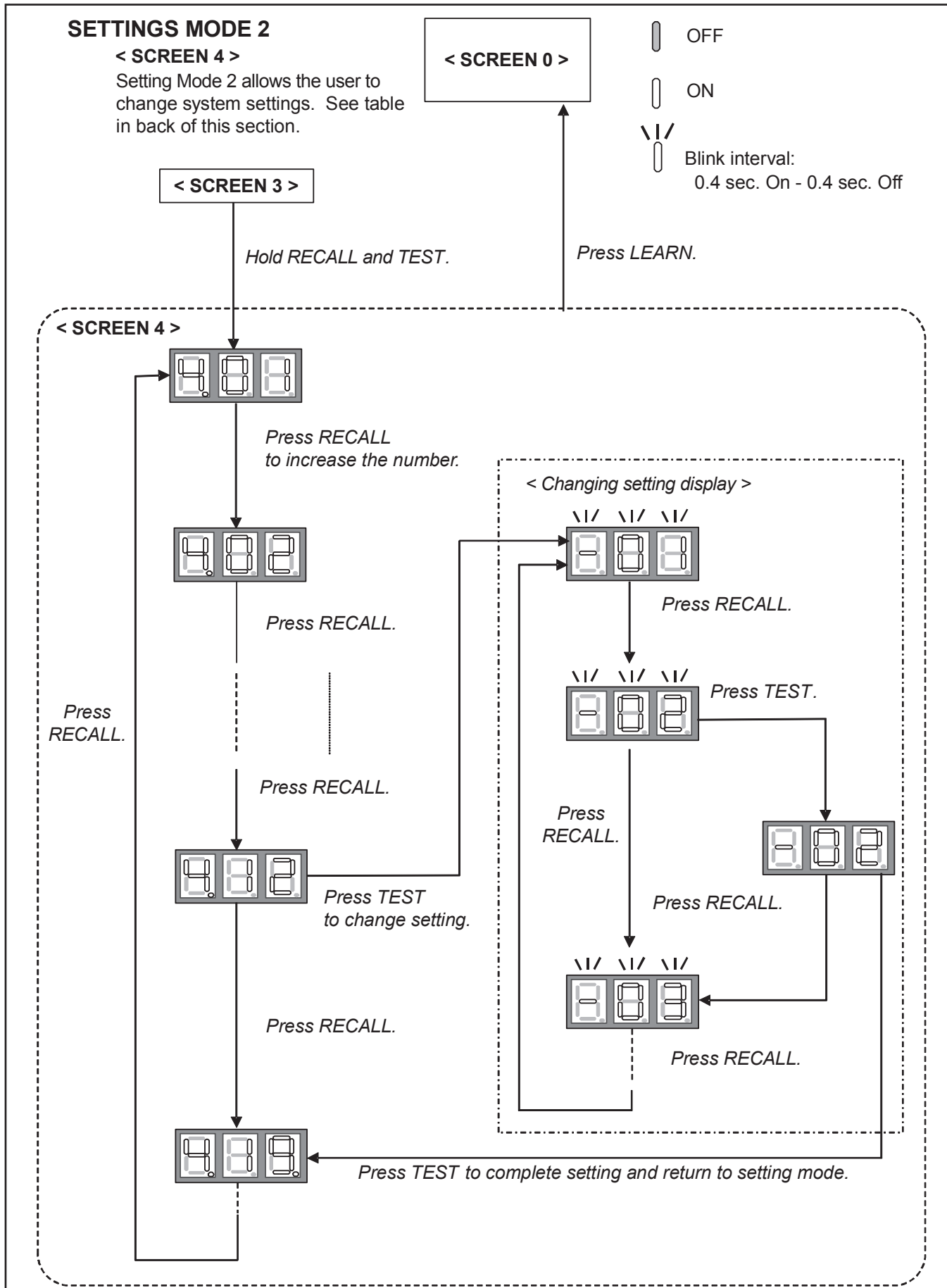

# 7-SEGMENT DISPLAY

## SCREEN 0 (Error code display)

Setting No.	Contents	Notes
1	Error code (present)	

## SCREEN 1 (Error code history)

Setting No.	Contents	Notes
1	Error code (latest)	Latest
2	Error code (2nd)	2nd
3	Error code (3rd)	3rd
4	Error code (4th)	4th
5	Error code (5th)	5th
6	Error code (6th)	6th

## SCREEN 2 (Monitoring mode)

Setting No.	Contents	Notes
1	Compressor operation time	unit: hr (Multiply by 200)
2	Operation code	0: Stop 1: Cooling Start-up 2: Heating Start-up* <sup>1</sup> 3: Oil Return Operation 4: Heating Operation* <sup>1</sup> 5: Defrost Operation* <sup>1</sup> 6: Cooling Operation
3	Compressor Reduction Mode	0:OFF, 1: ON
4	% Demand	unit: % (Cut off the decimal first place)
5	Act % demand	unit: % (Cut off the decimal first place)
6	Requested ID CFM	unit: CFM (Multiply by 10)
7	Reported ID CFM	unit: CFM (Multiply by 10)
8	Outdoor FAN RPM	unit: RPM (Multiply by 10)
9	Ta (Outdoor Air Temperature)	unit: F
10	Td (Outdoor Discharge Temperature)	unit: F
11	Tm (Outdoor Coil Temperature)	unit: F
12	Tb (Outdoor Coil Defrost Temperature)* <sup>1</sup>	unit: F
13	TI (Outdoor Liquid Temperature)	unit: F
14	Pressure sensor	unit: PSIG
15	Ts (Outdoor Suction Temperature)	unit: F

\*<sup>1</sup> HP only

# 7-SEGMENT DISPLAY

## SCREEN 3 (Setting mode 1)

Setting No.	Contents	Setting <sup>*2</sup>				Installer/ Serviceman Notes
1	Cool Airflow Trim High	0:-15% 1:-10% 2:-5% <b><u>3:0%</u></b>	4:5% 5:10% 6:15%			
2	Cool Airflow Trim Int	0:-15% 1:-10% 2:-5% <b><u>3:0%</u></b>	4:5% 5:10% 6:15% 7:20%	8:30% 9:Full		
3	Cool Airflow Trim Low	0:-15% 1:-10% 2:-5% <b><u>3:0%</u></b>	4:5% 5:10% 6:15% 7:20%	8:30% 9:Full		
4	Cool Profiles	0:A 1:B	2:C	<b><u>3:D</u></b>		
5	Cool Airflow ON Delay	<b><u>0:5sec.</u></b> 1:10sec.	2:20sec.	3:30sec.		
6	Cool Airflow OFF Delay	<b><u>0:30sec.</u></b> 1:60sec.	2:90sec.	3:120sec.		
7	Dehumidification	<b><u>0:STD</u></b>	1:OFF	2:A	3:B	4:C
8	Heat Airflow Trim High <sup>*1</sup>	0:-15% 1:-10% 2:-5% <b><u>3:0%</u></b>	4:5% 5:10% 6:15%			
9	Heat Airflow Trim Int <sup>*1</sup>	0:-15% 1:-10% 2:-5% <b><u>3:0%</u></b>	4:5% 5:10% 6:15%			
10	Heat Airflow Trim Low <sup>*1</sup>	0:-15% 1:-10% 2:-5% <b><u>3:0%</u></b>	4:5% 5:10% 6:15%			
11	Heat Airflow ON Delay <sup>*1</sup>	<b><u>0:5sec.</u></b>	1:10sec.	2:15sec.		
12	Heat Airflow OFF Delay <sup>*1</sup>	<b><u>0:30sec.</u></b> 1:50sec.	2:70sec.	3:90sec.		
13	Airflow Trim Offset <sup>*3</sup>	<b><u>0:0%</u></b>	1:+2.5%			
14	Zoning Mode	<b><u>0:OFF</u></b>	1:ON			
15	Circulation Selection	0:OFF	<b><u>1:ON</u></b>			

**NOTE:** Parameters as per factory setting are highlighted in bold and underlined.

<sup>\*1</sup> HP only

<sup>\*2</sup> The setting items can be different from this table depending on the outdoor unit model revision.

To confirm the setting specifications implemented, please see the attached installation manual, or the setting items displayed on the thermostat.

<sup>\*3</sup> Used for additional trim setting by adding 2.5% to basic airflow trim setting. This setting affects all trim settings except +15% High (cooling or heating).

# 7-SEGMENT DISPLAY

## SCREEN 4 (Setting mode 2)

Setting No.	Contents	Setting	Installer/ Serviceman Notes
1	Maximum Defrost Interval <sup>*1</sup>	0: 30min. 1: 60min. 2: 90min. <b>3: 120min.</b>	
4	System Verification Test (System test)	0:ON <b>1:OFF</b>	
7	Force Defrost Cycle <sup>*1</sup>	0:ON <b>1:OFF</b>	
9	Charge Verification Test	0:ON <b>1:OFF</b>	
10	Maximum Compressor RPS for Cooling	0: -10.0 RPS 1: -9.5 RPS 2: -9.0 RPS 3: -8.5 RPS 4: -8.0 RPS 5: -7.5 RPS 6: -7.0 RPS 7: -6.5 RPS 8: -6.0 RPS 9: -5.5 RPS 10: -5.0 RPS 11: -4.5 RPS 12: -4.0 RPS 13: -3.5 RPS 14: -3.0 RPS 15: -2.5 RPS 16: -2.0 RPS 17: -1.5 RPS 18: -1.0 RPS 19: -0.5 RPS <b>20: 0.0 RPS</b> 21: 0.5 RPS 22: 1.0 RPS 23: 1.5 RPS 24: 2.0 RPS 25: 2.5 RPS 26: 3.0 RPS 27: 3.5 RPS 28: 4.0 RPS 29: 4.5 RPS 30: 5.0 RPS 31: 5.5 RPS 32: 6.0 RPS 33: 6.5 RPS 34: 7.0 RPS 35: 7.5 RPS 36: 8.0 RPS 37: 8.5 RPS 38: 9.0 RPS 39: 9.5 RPS 40: 10.0 RPS	Can adjust comp RPS in each 0.5 RPS.
11	Maximum Compressor RPS for Heating <sup>*1</sup>		Can adjust comp RPS in each 0.5 RPS.
12	COOLING BOOST MODE Selection	<b>0:ON</b> 1:OFF	
13	COOLING BOOST MODE Temperature	0:105F, <b>1:100F</b> , 2:95F, 3:90F, 4:85F, 5:80F, 6:75F, 7:70F, 8:Always ON	
22	DEFROST HEAT <sup>*1 *2</sup>	0:Always ON, 1:30F, 2:35F, 3:40F, 4:45F, 5:50F, 6:55F, 7:60F, 8:65F, <b>9:OFF</b>	
28	HEATING BOOST MODE <sup>*1</sup>	<b>0:OFF</b> 1:ON	

<sup>\*1</sup> HP only

<sup>\*2</sup> 115 V Air Handler does not support this function. Set to "OFF".

**NOTE:** Parameters as per factory setting are highlighted in bold and underlined.

# TROUBLESHOOTING

## OUTDOOR UNIT ERROR CODES

Thermostat display	Control board LED Display	Description	Probable Causes	Corrective Actions
12	E12	Indicates a general memory error.	<ul style="list-style-type: none"> <li>High electrical noise</li> <li>Faulty control board</li> </ul>	<ul style="list-style-type: none"> <li>Replace control board if necessary</li> </ul>
13	E13	This error indicates the equipment is experiencing frequent high pressure faults. (CRITICAL)	<ul style="list-style-type: none"> <li>Blocked/restricted outdoor unit coil and/or lines</li> <li>Stop valve not completely open</li> <li>Overcharge</li> <li>Outdoor fan not running</li> <li>High pressure switch (HPS) inoperable</li> <li>Faulty indoor and outdoor EEV coil</li> <li>Faulty indoor and outdoor EEV</li> <li>Faulty control board</li> </ul>	<ul style="list-style-type: none"> <li>Check and clean outdoor unit coil and/or lines</li> <li>Check the opening of stop valve, should be full open; Repair/replace if needed</li> <li>Check refrigerant charge level; Adjust if needed</li> <li>Check outdoor fan motor &amp; wiring; Repair/replace if needed</li> <li>Check indoor and outdoor EEV; Replace if needed</li> <li>Check indoor and outdoor EEV coil; Replace if needed</li> <li>Replace control board if necessary</li> </ul>
14	-	This error indicates the equipment is experiencing frequent high pressure faults. Control has determined continued operation is acceptable. This indicates they may be a problem with the equipment. (MINOR)	<ul style="list-style-type: none"> <li>Blocked/restricted outdoor unit coil and/or lines</li> <li>Stop valve not completely open</li> <li>Overcharge</li> <li>Outdoor fan not running</li> <li>High pressure switch (HPS) inoperable</li> <li>Faulty indoor and outdoor EEV coil</li> <li>Faulty indoor and outdoor EEV</li> <li>Faulty control board</li> </ul>	<ul style="list-style-type: none"> <li>Check and clean outdoor unit coil and/or lines</li> <li>Check the opening of stop valve, should be full open; Repair/replace if needed</li> <li>Check refrigerant charge level; Adjust if needed</li> <li>Check outdoor fan motor &amp; wiring; Repair/replace if needed</li> <li>Check indoor and outdoor EEV; Replace if needed</li> <li>Check indoor and outdoor EEV coil; Replace if needed</li> <li>Replace control board if necessary</li> </ul>
15	E15	This error indicates the equipment is experiencing frequent low pressure faults. (CRITICAL)	<ul style="list-style-type: none"> <li>Stop valve not completely open</li> <li>Restriction in refrigerant lines</li> <li>Low refrigerant charge</li> <li>Refrigerant leak</li> <li>Pressure sensor inoperable or not properly connected</li> <li>Indoor fan motor not functioning correctly</li> <li>Faulty indoor and outdoor EEV coil</li> <li>Faulty indoor and outdoor EEV</li> <li>Faulty control board</li> </ul>	<ul style="list-style-type: none"> <li>Check the opening of stop valve, should be full open; Repair/replace if needed</li> <li>Check for restrictions in refrigerant line; Repair/replace if needed</li> <li>Check refrigerant charge level; Adjust if needed</li> <li>Test for system leaks using leak test procedure</li> <li>Check the connection to pressure sensor; Repair/replace if needed</li> <li>Check indoor and outdoor EEV; Replace if needed</li> <li>Check indoor and outdoor EEV coil; Replace if needed</li> <li>Check indoor blower motor &amp; wiring; Repair/replace if needed</li> <li>Replace control board if necessary</li> </ul>
16	-	This error indicates the equipment is experiencing frequent low pressure faults. Control has determined continued operation is acceptable. This indicates they may be a problem with the equipment. (MINOR)	<ul style="list-style-type: none"> <li>Stop valve not completely open</li> <li>Restriction in refrigerant lines</li> <li>Low refrigerant charge</li> <li>Refrigerant leak</li> <li>Pressure sensor inoperable or not properly connected</li> <li>Indoor fan motor not functioning correctly</li> <li>Faulty indoor and outdoor EEV coil</li> <li>Faulty indoor and outdoor EEV</li> <li>Faulty control board</li> </ul>	<ul style="list-style-type: none"> <li>Check the opening of stop valve, should be full open; Repair/replace if needed</li> <li>Check for restrictions in refrigerant line; Repair/replace if needed</li> <li>Check refrigerant charge level; Adjust if needed</li> <li>Test for system leaks using leak test procedure</li> <li>Check the connection to pressure sensor; Repair/replace if needed</li> <li>Check indoor and outdoor EEV; Replace if needed</li> <li>Check indoor and outdoor EEV coil; Replace if needed</li> <li>Check indoor blower motor &amp; wiring; Repair/replace if needed</li> <li>Replace control board if necessary</li> </ul>
17	E17	This error indicates the equipment is experiencing frequent compressor faults.	<ul style="list-style-type: none"> <li>Stop valve not completely open</li> <li>Faulty outdoor solenoid valve coil</li> <li>Faulty outdoor solenoid valve</li> <li>The compressor wire is lost phase</li> <li>Compressor motor failure</li> </ul>	<ul style="list-style-type: none"> <li>Check the opening of stop valve, should be full open; Repair/replace if needed</li> <li>Check outdoor solenoid valve coil; Repair/replace if needed</li> <li>Check outdoor solenoid valve; Replace/repair if needed</li> <li>Check the wire between control board and compressor</li> <li>Inspect compressor motor for proper function; Replace if necessary</li> </ul>
18	E18	Indicates the control board may need to be replaced.	<ul style="list-style-type: none"> <li>Outdoor fan motor not connected properly</li> <li>Faulty control board</li> <li>Electrical Noise</li> </ul>	<ul style="list-style-type: none"> <li>Check wiring from Outdoor fan motor to control board; Repair if needed</li> <li>Replace control board if necessary</li> </ul>
19	E19	This error indicates the equipment is experiencing frequent outdoor unit control board and/or motor faults.	<ul style="list-style-type: none"> <li>Obstruction in fan rotation</li> <li>Outdoor fan motor not connected properly</li> <li>Outdoor fan not running</li> <li>Faulty control board</li> <li>Electrical Noise</li> </ul>	<ul style="list-style-type: none"> <li>Check and clean grille of any debris</li> <li>Check wiring from Outdoor fan motor to control board; Repair if needed</li> <li>Check outdoor fan motor &amp; wiring; Repair/replace if needed</li> <li>Replace control board if necessary</li> </ul>
20	E20	This error indicates the equipment is experiencing outdoor EEV fault.	<ul style="list-style-type: none"> <li>Outdoor EEV coil is not connected</li> <li>Faulty outdoor EEV coil</li> <li>Faulty control board</li> </ul>	<ul style="list-style-type: none"> <li>Check outdoor EEV coil connection</li> <li>Repair/replace as needed</li> <li>Replace control board if necessary</li> </ul>
21	E21	This error indicates the equipment is experiencing frequent low discharge superheat faults.	<ul style="list-style-type: none"> <li>Thermistors inoperable or improperly connected</li> <li>Faulty indoor and outdoor EEV coil</li> <li>Faulty indoor and outdoor EEV</li> <li>Over charge</li> <li>Faulty pressure sensor</li> <li>Faulty control board</li> </ul>	<ul style="list-style-type: none"> <li>Check the connection to thermistors; Repair/replace if needed</li> <li>Check indoor and outdoor EEV coil; Repair/replace if needed</li> <li>Check indoor and outdoor EEV; Replace/repair if needed</li> <li>Check refrigerant charge level; Adjust if needed</li> <li>Check pressure sensor; Repair/replace if needed</li> <li>Replace control board if necessary</li> </ul>
22	E22	This error indicates the equipment is experiencing frequent high discharge temperature faults. Discharge thermistor is not put in correct position.	<ul style="list-style-type: none"> <li>Faulty outdoor solenoid valve coil</li> <li>Faulty outdoor solenoid valve</li> <li>Discharge thermistor inoperable or improperly connected</li> <li>Discharge thermistor is put in incorrect position or off</li> <li>The compressor enclosure temperature is too high</li> <li>Low refrigerant charge</li> <li>Overcharge</li> <li>Faulty compressor</li> </ul>	<ul style="list-style-type: none"> <li>Check outdoor solenoid valve coil; Repair/replace if needed</li> <li>Check outdoor solenoid valve; Replace/repair if needed</li> <li>Check discharge thermistor resistance and connections; Repair/replace as needed</li> <li>Check discharge thermistor position</li> <li>Check refrigerant charge level; Adjust if needed</li> <li>Check the compressor; Repair/replace if needed</li> </ul>
23	E23	The control has detected that the Discharge thermistor is out of range.	<ul style="list-style-type: none"> <li>Discharge thermistor inoperable or improperly connected</li> </ul>	<ul style="list-style-type: none"> <li>Check discharge thermistor resistance and connections; Repair/replace as needed</li> </ul>
24	E24	The high pressure switch is open.	<ul style="list-style-type: none"> <li>High pressure switch (HPS) inoperable</li> </ul>	<ul style="list-style-type: none"> <li>Check resistance on HPS to verify operation; Replace if needed</li> </ul>

# TROUBLESHOOTING

## OUTDOOR UNIT ERROR CODES

Thermostat display	Control board LED Display	Description	Probable Causes	Corrective Actions
25	E25	The outdoor air thermistor is open or shorted.	<ul style="list-style-type: none"> <li>Faulty outdoor air thermistor or not properly connected</li> </ul>	<ul style="list-style-type: none"> <li>Check the connection to outdoor air thermistor; Repair/replace if needed</li> </ul>
26	E26	The control determines that the pressure sensor is not reacting properly.	<ul style="list-style-type: none"> <li>Pressure sensor inoperable or not properly connected</li> </ul>	<ul style="list-style-type: none"> <li>Check the connection to pressure sensor; Repair/replace if needed</li> </ul>
27	E27	The control has detected that the Outdoor Coil Defrost thermistor is out of range.	<ul style="list-style-type: none"> <li>Outdoor coil defrost thermistor inoperable or not properly connected</li> </ul>	<ul style="list-style-type: none"> <li>Check the connection to OD coil defrost thermistor; Repair/replace if needed</li> </ul>
28	E28	The control has detected that the Outdoor heat exchanger thermistor is out of range.	<ul style="list-style-type: none"> <li>Outdoor heat exchanger thermistor inoperable or not properly connected</li> </ul>	<ul style="list-style-type: none"> <li>Check the connection to OD heat exchanger thermistor; Repair/replace if needed</li> </ul>
29	E29	The control has detected that the Liquid thermistor is out of range.	<ul style="list-style-type: none"> <li>Liquid thermistor inoperable or not properly connected</li> </ul>	<ul style="list-style-type: none"> <li>Check the connection to liquid thermistor; Repair/replace if needed</li> </ul>
30	E30	Indicates the control board may need to be replaced.	<ul style="list-style-type: none"> <li>Wiring to control board disconnected</li> <li>Faulty control board</li> <li>Electrical Noise</li> </ul>	<ul style="list-style-type: none"> <li>Check wiring to control board; Repair as needed</li> <li>Replace control board if necessary</li> </ul>
32	E32	This error indicates the equipment is experiencing high temperature faults on the outdoor unit control board.	<ul style="list-style-type: none"> <li>Ambient air conditions too high</li> <li>Stop valve not completely open</li> <li>Cooling bracket screw(s) missing or not properly fastened &lt;3.5 - 5.0 ton models and 3.0 - 4.0 ton Enhanced Capacity models only&gt;</li> <li>No or poor thermal grease coating between cooling plumbing and cooling bracket on control board &lt;3.5 - 5.0 ton models and 3.0 - 4.0 ton Enhanced Capacity models only&gt;</li> <li>No flow or limited flow through control board cooling circuit (potential restriction in line or low refrigerant) &lt;3.5 - 5.0 ton models and 3.0 - 4.0 ton Enhanced Capacity models only&gt;</li> </ul>	<ul style="list-style-type: none"> <li>Cycle power; re-try during usable ambient temperature range</li> <li>Check grease applying condition &lt;3.5 - 5.0 ton models and 3.0 - 4.0 ton Enhanced Capacity models only&gt;</li> <li>Check screw tightening condition &lt;3.5 - 5.0 ton models and 3.0 - 4.0 ton Enhanced Capacity models only&gt;</li> <li>Check for restriction in line</li> <li>Check refrigerant charge level; Adjust if needed</li> <li>Check the opening of stop valve, should be full open; Repair/replace if needed</li> </ul>
33	-	This error indicates the equipment is experiencing high temperature faults on the outdoor unit control board. Control has determined continued operation is acceptable. This indicates they may be a problem with the equipment.	<ul style="list-style-type: none"> <li>Ambient air conditions too high</li> <li>Stop valve not completely open</li> <li>Cooling bracket screw(s) missing or not properly fastened &lt;3.5 - 5.0 ton models and 3.0 - 4.0 ton Enhanced Capacity models only&gt;</li> <li>No or poor thermal grease coating between cooling plumbing and cooling bracket on control board &lt;3.5 - 5.0 ton models and 3.0 - 4.0 ton Enhanced Capacity models only&gt;</li> <li>No flow or limited flow through control board cooling circuit (potential restriction in line or low refrigerant) &lt;3.5 - 5.0 ton models and 3.0 - 4.0 ton Enhanced Capacity models only&gt;</li> </ul>	<ul style="list-style-type: none"> <li>Cycle power; re-try during usable ambient temperature range</li> <li>Check grease applying condition &lt;3.5 - 5.0 ton models and 3.0 - 4.0 ton Enhanced Capacity models only&gt;</li> <li>Check screw tightening condition &lt;3.5 - 5.0 ton models and 3.0 - 4.0 ton Enhanced Capacity models only&gt;</li> <li>Check for restriction in line</li> <li>Check refrigerant charge level; Adjust if needed</li> <li>Check the opening of stop valve, should be full open; Repair/replace if needed</li> </ul>
34	E34	Control board detected a high current condition. This indicates the potential for a short circuit.	<ul style="list-style-type: none"> <li>Current spike in supply</li> <li>Stop valve not completely open</li> <li>The compressor wire is lost phase</li> <li>Faulty control board</li> <li>Faulty compressor</li> </ul>	<ul style="list-style-type: none"> <li>Check power supply for in-rush current during start-up or steady state operation</li> <li>Check the opening of stop valve, should be full open; Repair/replace if needed</li> <li>Check the wire between control board and compressor</li> <li>Replace control board if necessary</li> <li>Check the compressor; Repair/replace if needed</li> </ul>
35	E35	Control board detected a high current condition.	<ul style="list-style-type: none"> <li>Air re-circulation on outdoor unit</li> <li>Stop valve not completely open</li> <li>Overcharge</li> <li>Faulty control board</li> <li>Faulty compressor</li> </ul>	<ul style="list-style-type: none"> <li>Check installation clearances.</li> <li>Check the opening of stop valve, should be full open; Repair/replace if needed</li> <li>Check refrigerant charge level; Adjust if needed</li> <li>Replace control board if necessary</li> <li>Check the compressor; Repair/replace if needed.</li> </ul>
36	E36	The control encountered an abnormal condition during the startup procedure.	<ul style="list-style-type: none"> <li>Faulty outdoor solenoid valve coil</li> <li>Faulty outdoor solenoid valve</li> <li>Blocked/restricted outdoor unit coil and/or lines</li> <li>The compressor wire is lost phase</li> <li>Inconsistent compressor load</li> <li>Faulty control board</li> </ul>	<ul style="list-style-type: none"> <li>Check outdoor solenoid valve coil; Repair /replace if needed</li> <li>Check outdoor solenoid valve; Replace /repair if needed</li> <li>Check and clean outdoor unit coil and/or lines</li> <li>Check the wire between control board and compressor</li> <li>Replace control board if necessary</li> </ul>
37	E37	Indicates the control board may need to be replaced.	<ul style="list-style-type: none"> <li>Outdoor fan motor not connected properly</li> <li>Faulty control board</li> </ul>	<ul style="list-style-type: none"> <li>Check wiring from Outdoor fan motor to control board; Repair if needed</li> <li>Replace control board if necessary</li> </ul>
38	E38	The control has detected a voltage related issue with the compressor.	<ul style="list-style-type: none"> <li>High or low voltage from supply</li> <li>The compressor wire is lost phase</li> <li>Faulty control board</li> </ul>	<ul style="list-style-type: none"> <li>Correct low/high line voltage condition; Contact local utility if needed</li> <li>Check the wire between control board and compressor</li> <li>Replace control board if necessary</li> </ul>
39	E39	Indicates the control board may need to be replaced.	<ul style="list-style-type: none"> <li>Thermistors inoperable or improperly connected</li> <li>Faulty control board</li> </ul>	<ul style="list-style-type: none"> <li>Check the connection to thermistors; Repair/replace if needed</li> <li>Replace control board if necessary</li> </ul>
40	E40	Control determines that its compressor requirement is different than the compressor capability.	<ul style="list-style-type: none"> <li>Memory card not correct</li> <li>Control board mismatch</li> </ul>	<ul style="list-style-type: none"> <li>Check memory card data vs. outdoor unit model</li> <li>Verify control board size vs. outdoor unit model; Replace control board if necessary</li> </ul>
41	E41	The control has detected a low refrigerant condition.	<ul style="list-style-type: none"> <li>Refrigerant leak</li> <li>Low refrigerant charge</li> <li>Thermistors inoperable or not properly connected</li> <li>Faulty outdoor solenoid valve coil</li> <li>Faulty outdoor solenoid valve</li> </ul>	<ul style="list-style-type: none"> <li>Test for system leaks using leak test procedure</li> <li>Check refrigerant charge level; Adjust if needed</li> <li>Check the connection to thermistor; Repair/replace if needed</li> <li>Check outdoor solenoid valve coil; Repair /replace if needed</li> <li>Check outdoor solenoid valve; Replace /repair if needed</li> </ul>
42	E42	Control detects a low power supply voltage condition.	<ul style="list-style-type: none"> <li>Low line voltage supply</li> </ul>	<ul style="list-style-type: none"> <li>Check circuit breakers and fuses; Replace if needed</li> <li>Verify unit is connected to power supply as specified on rating plate</li> <li>Correct low line voltage condition; Contact local utility if needed</li> </ul>

# TROUBLESHOOTING

## OUTDOOR UNIT ERROR CODES

Thermostat display	Control board LED Display	Description	Probable Causes	Corrective Actions
43	E43	Control detects a high power supply voltage condition.	<ul style="list-style-type: none"> <li>High line voltage supply</li> </ul>	<ul style="list-style-type: none"> <li>Verify unit is connected to power supply as specified on rating plate</li> <li>Correct high line voltage condition; Contact local utility if needed</li> </ul>
44	E44	The control detects the outdoor temperature outside recommended operational range. Unit may continue to operate normally.	<ul style="list-style-type: none"> <li>Ambient air conditions too high or low</li> </ul>	<ul style="list-style-type: none"> <li>Cycle power; re-try during usable ambient temperature range</li> </ul>
47	E47	The control is unable to start the System Verification test because indoor heat has been turned on by thermostat. Please set thermostat to off position.	<ul style="list-style-type: none"> <li>Heat provided by secondary heating source</li> </ul>	<ul style="list-style-type: none"> <li>Turn off Furnace or heater using thermostat before operation</li> </ul>
49	E49	The control is unable to enter Charging Mode because indoor heat has been turned on by thermostat. Please set thermostat to off position.	<ul style="list-style-type: none"> <li>Heat provided by secondary heating source</li> </ul>	<ul style="list-style-type: none"> <li>Turn off heater using thermostat before operation</li> </ul>
50	E50	This indicates there is a voltage issue on the control board. See service manual for troubleshooting information.	<ul style="list-style-type: none"> <li>High or low voltage from supply voltage or frequency</li> <li>Faulty control board</li> <li>Noise</li> </ul>	<ul style="list-style-type: none"> <li>Correct low/high line voltage condition; Contact local utility if needed</li> <li>Replace control board if necessary</li> <li>Contact local utility if needed</li> </ul>
51 <sup>*1</sup>	E51	This indicates potential communication issues have been detected by the outdoor unit control board.	<ul style="list-style-type: none"> <li>Communication wiring disconnected</li> </ul>	<ul style="list-style-type: none"> <li>Check communication wiring; Repair as needed</li> </ul>
52	-	This error indicates the equipment is experiencing frequent compressor faults. Control has determined continued operation is acceptable. This indicates they may be a problem with the equipment.	<ul style="list-style-type: none"> <li>Stop valve not completely open</li> <li>The compressor wire is lost phase</li> <li>Compressor motor failure</li> </ul>	<ul style="list-style-type: none"> <li>Check the opening of stop valve, should be full open; Repair/replace if needed</li> <li>Check the wire between control board and compressor</li> <li>Inspect compressor motor for proper function; Replace if necessary</li> </ul>
53	-	This error indicates the equipment is experiencing frequent outdoor unit control board and/or motor faults. Control has determined continued operation is acceptable. This indicates they may be a problem with the equipment.	<ul style="list-style-type: none"> <li>Obstruction in fan rotation</li> <li>Outdoor fan motor not connected properly</li> <li>Outdoor fan not running</li> <li>Faulty control board</li> <li>Noise</li> </ul>	<ul style="list-style-type: none"> <li>Check and clean grille of any debris</li> <li>Check wiring from Outdoor fan motor to control board; Repair if needed</li> <li>Check outdoor fan motor &amp; wiring; Repair/replace if needed</li> <li>Replace control board if necessary</li> </ul>
54	-	This error indicates the equipment is experiencing frequent low discharge superheat faults. Control has determined continued operation is acceptable. This indicates they may be a problem with the equipment.	<ul style="list-style-type: none"> <li>Thermistors inoperable or improperly connected</li> <li>Faulty indoor EEV or indoor EEV coil (when cooling)</li> <li>Faulty control board</li> <li>Faulty outdoor EEV or outdoor EEV coil (when heating)</li> </ul>	<ul style="list-style-type: none"> <li>Check the connection to thermistors; Repair/replace if needed</li> <li>Check indoor EEV; Replace if needed</li> <li>Check indoor EEV coil; Replace if needed</li> <li>Replace control board if necessary</li> <li>Check outdoor EEV; Replace if needed</li> <li>Check outdoor EEV coil; Replace if needed</li> </ul>
55	-	This error indicates the equipment is experiencing frequent high discharge temperature faults. Control has determined continued operation is acceptable. This indicates they may be a problem with the equipment.	<ul style="list-style-type: none"> <li>Discharge thermistor inoperable or improperly connected</li> <li>Discharge thermistor is put in incorrect position or off</li> <li>Low refrigerant charge</li> <li>Overcharge</li> <li>Faulty compressor</li> </ul>	<ul style="list-style-type: none"> <li>Check discharge thermistor resistance and connections; Repair/replace as needed</li> <li>Check discharge thermistor position</li> <li>Check refrigerant charge level; Adjust if needed</li> <li>Check the compressor; Repair/replace if needed</li> </ul>
56	E56	The control has detected if the Outdoor Suction thermistor is out of range.	<ul style="list-style-type: none"> <li>Outdoor suction thermistor inoperable or not properly connected</li> <li>Faulty reversing valve</li> </ul>	<ul style="list-style-type: none"> <li>Check the connection to outdoor suction thermistor; Repair/replace if needed</li> <li>Check reversing valve; Replace if needed</li> </ul>
-	E57 <sup>*2</sup>	This indicates the control is sensing sweating on the cooling loop. <3.5 - 5.0 ton models and 3.0 - 4.0 ton Enhanced Capacity models only>	<ul style="list-style-type: none"> <li>Refrigerant Leak</li> <li>Low refrigerant charge</li> <li>Faulty indoor EEV or indoor EEV coil</li> <li>Thermistors inoperable or improperly connection</li> </ul>	<ul style="list-style-type: none"> <li>Test for system leaks using leak test procedure</li> <li>Check refrigerant charge level; Adjust if needed</li> <li>Check indoor EEV; Replace if needed</li> <li>Check indoor EEV coil; Replace if needed</li> <li>Check the connection to thermistors; Repair/replace if needed</li> </ul>

(\*1) Network communication error (Refer to "NETWORK TROUBLESHOOTING")

(\*2) Check the error code history of the outdoor unit, when it is not displayed on the thermostat.

# TROUBLESHOOTING

## OUTDOOR UNIT ERROR CODES

Thermostat display	Control board LED Display	Description	Probable Causes	Corrective Actions
58	E58	The Overload Protection sensor for Compressor is opened.	<ul style="list-style-type: none"> <li>Overload protection (OL) sensor inoperable</li> <li>OL sensor (X33A) is put in incorrect position or off</li> </ul>	<ul style="list-style-type: none"> <li>Check resistance on OL sensor to verify operation; Replace if needed.</li> <li>Check OL sensor position on compressor body.</li> <li>Check OL sensor connection (X33A)</li> </ul>
B0	Eb0	The estimated airflow from indoor subsystem is near to 0 CFM.	<ul style="list-style-type: none"> <li>Failed indoor blower motor</li> <li>Indoor fan motor not properly connected</li> <li>Too much static pressure</li> </ul>	<ul style="list-style-type: none"> <li>Check ID fan motor wiring and connectors; Repair/replace if needed</li> <li>Check ID fan motor; Replace if needed</li> <li>Check the obstruction inside duct work.</li> </ul>
B9	Eb9	Estimated airflow from motor is lower than the airflow requirement.	<ul style="list-style-type: none"> <li>Failed indoor blower motor</li> <li>Indoor fan motor not properly connected</li> <li>Too much static pressure</li> </ul>	<ul style="list-style-type: none"> <li>Check ID fan motor wiring and connectors; Repair/replace if needed</li> <li>Check ID fan motor; Replace if needed</li> </ul>
D0	Ed0	Control board does not have the necessary data for it to properly perform its functions.	<ul style="list-style-type: none"> <li>Outdoor unit is wired as part of a communicating system and integrated control module does not contain any shared data.</li> </ul>	<ul style="list-style-type: none"> <li>Replace control board if necessary</li> </ul>
D1	Ed1	Control board does not have the appropriate data needed to properly perform its functions.	<ul style="list-style-type: none"> <li>Outdoor unit is wired as part of a communicating system and integrated control module contains invalid shared data or network data is invalid for the integrated control module.</li> </ul>	<ul style="list-style-type: none"> <li>Replace control board if necessary</li> </ul>
D2	Ed2	The airflow requirement is greater than the airflow capability of the indoor subsystem.	<ul style="list-style-type: none"> <li>Outdoor unit is wired as part of a communicating system and outdoor unit requires airflow greater than indoor unit's airflow capability, or a type of indoor unit without EEV is connected to the system.</li> <li>Shared data is incompatible the system or missing parameters</li> <li>Communication wiring with indoor unit has loose connection.</li> <li>Airflow trim setting is out of range.</li> </ul>	<ul style="list-style-type: none"> <li>Check combination to be matched with rating list; correct if needed.</li> <li>Verify shared data is correct for your specific model; Repopulate data if required</li> <li>Check communication wiring and power supply wiring of indoor unit. Repair as needed.</li> <li>Verify airflow trim setting and adjust if needed. Refer to page 58 for the range of airflow trim setting.</li> </ul>
D3	Ed3	There is a mismatch between the shared data and the control physical hardware.	<ul style="list-style-type: none"> <li>Shared data sent to integrated control module does not match hardware configuration.</li> </ul>	<ul style="list-style-type: none"> <li>Verify shared data is correct for your specific model; Repopulate data if required</li> </ul>
D4	Ed4	The memory card data has been rejected.	<ul style="list-style-type: none"> <li>Shared data on memory card has been rejected.</li> </ul>	<ul style="list-style-type: none"> <li>Verify shared data is correct for your specific model; Repopulate data if required</li> </ul>

Items below are messages only displayed on the thermostat screen.

11	E11	This test is required at startup. Installer should navigate to the thermostat menu to run SYSTEM START-UP TEST. This code will clear once testing is complete.	<ul style="list-style-type: none"> <li>Incomplete SYSTEM START-UP TEST</li> <li>SYSTEM START-UP TEST is running</li> </ul>	Run the SYSTEM START-UP TEST. (See the installation manual of the outdoor unit, "STEP3. SYSTEM START-UP TEST")
----	-----	--	--	--

Error Code

# E13

## High pressure error

### 1 Applicable Models

Outdoor AC  
Outdoor HP

### 2 Method of Error Detection

[Cooling]

Heat exchanger thermistor

[Heating]

ID pressure sensor

### 3 Error Decision Conditions

When the pressure is higher than 4.2 MPa (605 PSIG).

### 4 Supposed Causes

- Blocked/restricted outdoor unit coil and/or lines
- Stop valve not completely open
- Overcharge
- Outdoor fan not running
- High pressure switch (HPS) inoperable
- Faulty indoor and outdoor EEV coil
- Faulty indoor and outdoor EEV
- Faulty control board

### 5. Troubleshooting

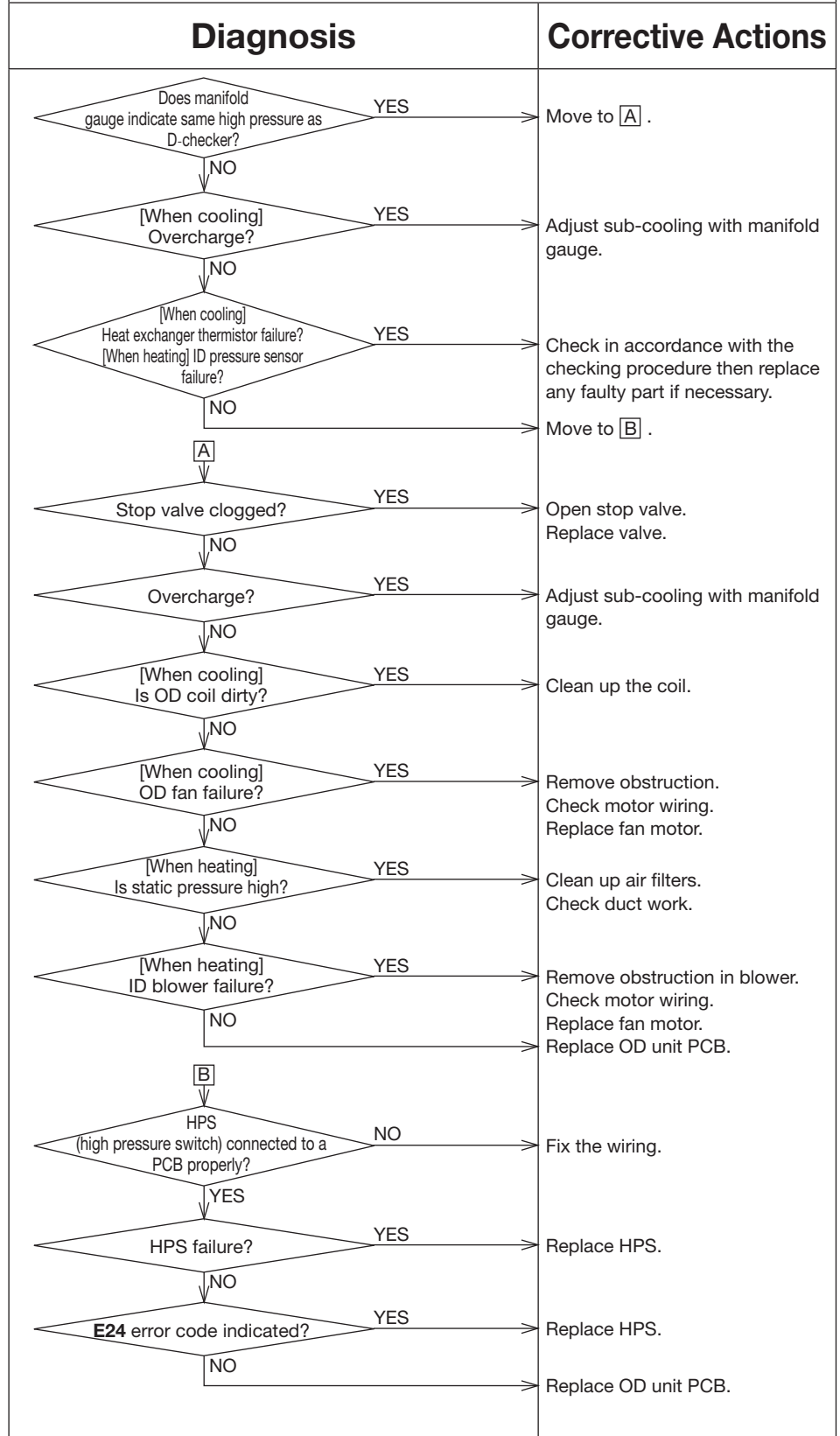

Error Code <b>E15</b>	<b>Low pressure error</b>
--------------------------	---------------------------

1 Applicable Models	5. Troubleshooting	
Outdoor AC Outdoor HP	<b>Diagnosis</b>	<b>Corrective Actions</b>
<b>2 Method of Error Detection</b>	<pre>                     graph TD                         Q1{Does manifold gauge indicate same low pressure as D-checker?} -- YES --&gt; A1[Move to A.]                         Q1 -- NO --&gt; Q2{OD pressure sensor failure?}                         Q2 -- YES --&gt; A2[Check in accordance with the checking procedure then replace any faulty part if necessary. Replace OD unit PCB.]                         Q2 -- NO --&gt; A[A]                         A --&gt; Q3{Stop valve clogged?}                         Q3 -- YES --&gt; A3[Open stop valve. Replace valve.]                         Q3 -- NO --&gt; Q4{Undercharge?}                         Q4 -- YES --&gt; A4[Adjust sub-cooling with manifold gauge. Check refrigerant leak.]                         Q4 -- NO --&gt; Q5{Is the following thermistor failure? [in cooling] Indoor gas temp [in heating] Suction temp}                         Q5 -- YES --&gt; A5[Replace the faulty thermistor.]                         Q5 -- NO --&gt; Q6{Is there temperature differential between before and after EEV? [in cooling] OD EEV [in heating] ID EEV}                         Q6 -- YES --&gt; A6[Check EEV coil then replace if necessary. Replace EEV if EEV coil have no failure.]                         Q6 -- NO --&gt; Q7{Is there temperature differential between before and after EEV? [in cooling] ID EEV [in heating] OD EEV}                         Q7 -- YES --&gt; A7[Check EEV coil then replace if necessary. Replace EEV if EEV coil have no failure.]                         Q7 -- NO --&gt; Q8{Check all refrigerant filter and dryer in circuit, also check any kink in piping. Clogging suspected?}                         Q8 -- YES --&gt; A8[Replace the clogged parts.]                         Q8 -- NO --&gt; Q9{[When cooling] ID fan failure? Is static pressure high? [When heating] OD fan failure?}                         Q9 -- YES --&gt; A9[Remove obstruction. Check motor wiring. Replace fan motor. Clean up air filters. Check duct work.]                         Q9 -- NO --&gt; A10[Replace OD unit PCB.]                     </pre>	
<b>3 Error Decision Conditions</b>		
When the pressure is less than criteria for 5 minutes. <b>[Cooling]</b> 0.12 MPa (17 PSIG) <b>[Heating]</b> 0.12 MPa (17 PSIG)		
<b>4 Supposed Causes</b>		
<ul style="list-style-type: none"> <li>● Stop valve not completely open</li> <li>● Restriction in refrigerant lines</li> <li>● Low refrigerant charge</li> <li>● Refrigerant leak</li> <li>● Pressure sensor inoperable or not properly connected</li> <li>● Indoor fan motor not functioning correctly</li> <li>● Faulty indoor and outdoor EEV coil</li> <li>● Faulty indoor and outdoor EEV</li> <li>● Faulty control board</li> </ul>		

Error Code

# E21

## EEV control error

### 1 Applicable Models

Outdoor AC  
Outdoor HP

### 2 Method of Error Detection

Detected by discharge pipe superheat and EEV pulse.

### 3 Error Decision Conditions

When discharge pipe superheat became excessive low (< 5°C (9°F)) and EEV pulse is minimum.

### 4 Supposed Causes

- Thermistors inoperable or improperly connected
- Faulty indoor and outdoor EEV coil
- Faulty indoor and outdoor EEV
- Overcharge
- Faulty pressure sensor
- Faulty control board

### 5. Troubleshooting

Diagnosis	Corrective Actions
<p>Charge amount of refrigerant is correct?</p> <p>NO →</p> <p>YES ↓</p>	<p>Charge refrigerant correctly.</p>
<p>Indoor and outdoor EEV coils are connected to PCB properly?</p> <p>NO →</p> <p>YES ↓</p>	<p>Connect properly.</p>
<p>Indoor and outdoor EEV coils are attached to EEV body properly? (*1)</p> <p>NO →</p> <p>YES ↓</p>	<p>Attach EEV coil properly.</p>
<p>Coil resistance of EEV is normal?</p> <p>NO →</p> <p>YES ↓</p>	<p>Replace EEV coil.</p>
<p>Thermistors are connected properly?</p> <p>NO →</p> <p>YES ↓</p>	<p>Connect properly.</p>
<p>Characteristics of thermistors are normal?</p> <p>NO →</p> <p>YES ↓</p>	<p>Replace thermistors.</p>
<p>Characteristic of pressure sensor is normal?</p> <p>NO →</p> <p>YES ↓</p>	<p>Replace pressure sensor.</p>
	<p>Replace PCB.</p>

\*1: Check if EEV coil is correctly secured to EEV body. Protrusion on EEV coil should be clicked into place on dimple of EEV body.

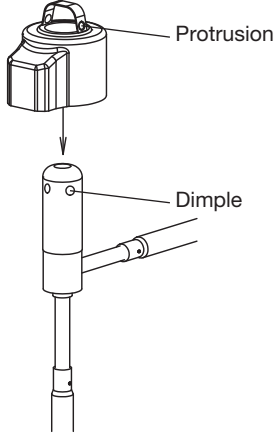

Error Code <b>E22</b>	<b>High discharge temperature error</b>
--------------------------	---

<b>1 Applicable Models</b>
Outdoor AC Outdoor HP
<b>2 Method of Error Detection</b>
Detected by discharge temperature.
<b>3 Error Decision Conditions</b>
When discharge temperature became excessive high.
<b>4 Supposed Causes</b>
<ul style="list-style-type: none"> <li>● Discharge thermistor inoperable or improperly connected</li> <li>● Discharge thermistor is put in incorrect position or off</li> <li>● OL sensor is put in incorrect position or off</li> <li>● The compressor enclosure temperature is too high</li> <li>● Low refrigerant charge</li> <li>● Overcharge</li> <li>● Faulty compressor</li> </ul>

<b>5. Troubleshooting</b>	
Diagnosis	Corrective Actions
Discharge temperature is higher than the criterion (120°C (248°F)).	YES → Check refrigerant leak. Check compressor fault.
NO → Discharge thermistor is connected to PCB properly?	NO → Connect properly.
YES → Discharge thermistor is connected to discharge pipe properly?	NO → Connect properly.
YES → Characteristic of discharge thermistor is normal?	NO → Replace thermistors.
YES → Indoor and outdoor EEV coils are connected to PCB properly?	NO → Connect properly.
YES → Indoor and outdoor EEV coils are attached to EEV body properly? (*1)	NO → Attach EEV coil properly.
YES → Coil resistance of EEV is normal?	NO → Replace EEV coil.
YES →	Replace PCB.
*1: Check if EEV coil is correctly secured to EEV body. Protrusion on EEV coil should be clicked into place on dimple of EEV body.	

Error Code

# E32

## Outdoor PCB high temperature error

### 1 Applicable Models

Outdoor AC 1.5 - 3.0 ton  
 Outdoor HP 1.5 - 3.0 ton  
 Outdoor Enhanced HP 2.0 ton  
 Outdoor High Efficiency AC 2.0 ton

### 2 Method of Error Detection

Detected by thermistor on inverter cooling fin.

### 3 Error Decision Conditions

When the temperature became excessive high.

### 4 Supposed Causes

- Ambient air conditions too high
- Poor cooling of cooling fin
- Inlet or outlet of air path is clogged.
- Dirty cooling fin
- Outdoor PCB malfunction

### 5. Troubleshooting

#### Diagnosis

Check inverter fin temperature with D-checker. **E32** occurs when the temperature exceeds or is close to the reference value.  
 Criteria: 101°C (214°F)

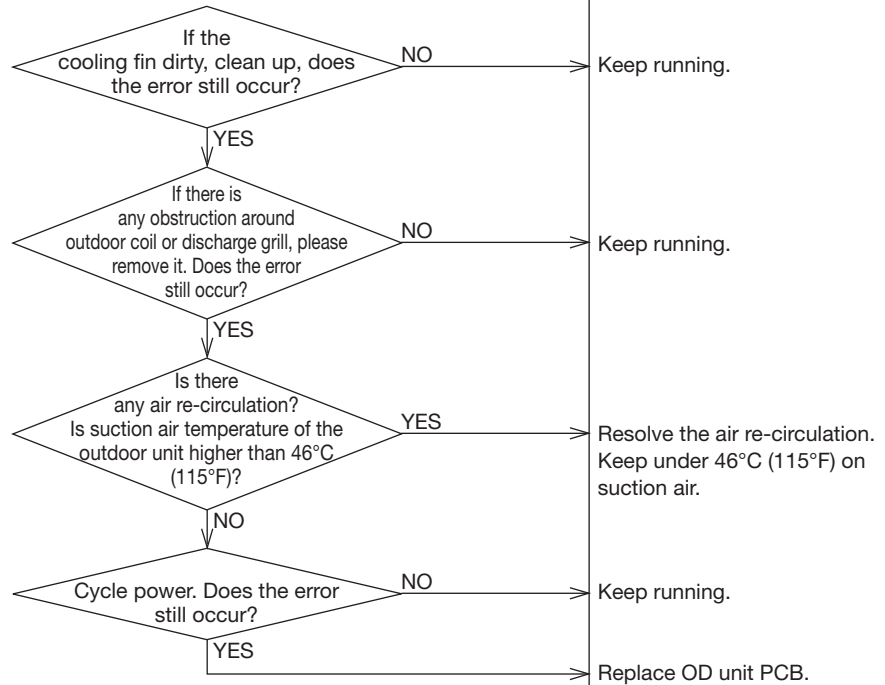

#### Corrective Actions

Error Code <b>E32</b>	<b>Outdoor PCB high temperature error</b>
--------------------------	---

1 Applicable Models	5. Troubleshooting	
Outdoor AC 3.5 - 5.0 ton Outdoor HP 3.5 - 5.0 ton Outdoor Enhanced HP 3.0 - 4.0 ton Outdoor High Efficiency AC 3.0 - 4.0 ton	Diagnosis	Corrective Actions
<b>2 Method of Error Detection</b> Detected by thermistor on inverter cooling plate.	<div style="border: 1px solid black; padding: 5px; margin-bottom: 10px;">                         Check inverter fin temperature with D-checker. <b>E32</b> occurs when the temperature exceeds or is close to the reference value.                          Criteria: 110°C (230°F)                     </div> <pre>                     graph TD                         Q1{Is the liquid tubing all the way contacting to a cooling plate?}                         Q2{All four nails of cooling plate have hooked into square holes? All screws of cooling plate cover tightened with proper torque 1.59±0.20 N·m (1.17±0.15 lb-ft)?}                         Q3{Have grease already been replaced to new grease on a cooling plate?}                         Q4{Is the R7T thermistor connected to a connector on a PCB correctly?}                         Q5{Clogging refrigerant circuit?}                         Q6{Is amount of charge correct? SH is proper?}                         Q7{Is there any air re-circulation? Is suction air temperature of the outdoor unit higher than 46°C (115°F)?}                         Q8{Cycle power. Does the error still occur?}                          Q1 -- NO --&gt; A1[Fix the liquid tubing to contact surely to cooling plate.]                         Q1 -- YES --&gt; Q2                         Q2 -- NO --&gt; A2[Secure the cooling plate cover with proper torque.]                         Q2 -- YES --&gt; Q3                         Q3 -- NO --&gt; A3[Replace the grease.]                         Q3 -- YES --&gt; Q4                         Q4 -- NO --&gt; A4[Correct the miss-connection.]                         Q4 -- YES --&gt; Q5                         Q5 -- YES --&gt; A5[Resolve the clogging.]                         Q5 -- NO --&gt; Q6                         Q6 -- NO --&gt; A6[Adjust charge per IO manual.]                         Q6 -- YES --&gt; Q7                         Q7 -- YES --&gt; A7[Resolve the air re-circulation. Keep under 46°C (115°F) on suction air.]                         Q7 -- NO --&gt; Q8                         Q8 -- NO --&gt; A8[Keep running.]                         Q8 -- YES --&gt; A9[Replace OD unit PCB.]                     </pre>	
<b>3 Error Decision Conditions</b> When the temperature became excessive high.		
<b>4 Supposed Causes</b> <ul style="list-style-type: none"> <li>● Ambient air conditions too high</li> <li>● Stop valve not completely open</li> <li>● Cooling bracket screw(s) missing or not properly fastened</li> <li>● No or poor thermal grease coating between refrigerant tubing and cooling plate on control board</li> <li>● No refrigerant flow or limited flow (any restriction in circuit or undercharge)</li> <li>● Outdoor PCB malfunction</li> </ul>		

Error Code <b>E41</b>	<b>Refrigerant shortage</b>
--------------------------	-----------------------------

<h3>1 Applicable Models</h3> <p>Outdoor AC Outdoor HP</p>	<h3>5. Troubleshooting</h3>						
<h3>2 Method of Error Detection</h3> <p><b>[Cooling]</b> OD pressure sensor ID liquid thermistor</p> <p><b>[Heating]</b> OD discharge thermistor OD liquid thermistor OD outdoor air thermistor ID pressure sensor</p>	<table border="1" style="width: 100%;"> <thead> <tr> <th style="width: 50%;">Diagnosis</th> <th style="width: 50%;">Corrective Actions</th> </tr> </thead> <tbody> <tr> <td> <p><b>Cooling</b></p> <p>Is amount of charge correct? SH is proper?</p> <p>NO → Adjust charge per IO manual.</p> <p>YES → Check any clogging in refrigerant circuit.</p> </td> <td></td> </tr> <tr> <td> <p><b>Heating</b></p> <p>For compressor wiring, any open circuit or connected to a wrong terminal?</p> <p>YES → Fix the wiring issue.</p> <p>NO</p> <p>Is amount of charge correct? SH is proper?</p> <p>NO → Adjust charge per IO manual.</p> <p>YES</p> <p>Clogging refrigerant circuit?</p> <p>YES → Resolve the clogging.</p> <p>NO</p> <p>Check D-checker data</p> <p>Other → Replace OD unit PCB.</p> <p>Disch temp. - Cond temp. &gt; 75°C (135°F)</p> <p>Measure discharge temp and high pressure then compare with D-checker data. Obviously different?</p> <p>YES → Replace failed sensor if necessary.</p> <p>NO → Replace OD unit PCB.</p> <p><b>&amp;</b> [ 3.5 - 5.0 ton models and 3.0 - 4.0 ton Enhanced Capacity/High Efficiency models Outdoor air temp. - 2°C (4°F) &gt; Liquid pipe temp.</p> <p>Measure OD air temperature then compare with D-checker data. Obviously different?</p> <p>YES → Replace failed sensor if necessary.</p> <p>NO</p> <p>Measure liquid tubing temp beside of OD liquid thermistor then compare with D-checker data. Obviously different?</p> <p>YES → Replace failed sensor if necessary.</p> <p>NO → Install thermal insulation onto liquid tubing exposed to outdoor to keep warm.</p> </td> <td></td> </tr> </tbody> </table>	Diagnosis	Corrective Actions	<p><b>Cooling</b></p> <p>Is amount of charge correct? SH is proper?</p> <p>NO → Adjust charge per IO manual.</p> <p>YES → Check any clogging in refrigerant circuit.</p>		<p><b>Heating</b></p> <p>For compressor wiring, any open circuit or connected to a wrong terminal?</p> <p>YES → Fix the wiring issue.</p> <p>NO</p> <p>Is amount of charge correct? SH is proper?</p> <p>NO → Adjust charge per IO manual.</p> <p>YES</p> <p>Clogging refrigerant circuit?</p> <p>YES → Resolve the clogging.</p> <p>NO</p> <p>Check D-checker data</p> <p>Other → Replace OD unit PCB.</p> <p>Disch temp. - Cond temp. &gt; 75°C (135°F)</p> <p>Measure discharge temp and high pressure then compare with D-checker data. Obviously different?</p> <p>YES → Replace failed sensor if necessary.</p> <p>NO → Replace OD unit PCB.</p> <p><b>&amp;</b> [ 3.5 - 5.0 ton models and 3.0 - 4.0 ton Enhanced Capacity/High Efficiency models Outdoor air temp. - 2°C (4°F) &gt; Liquid pipe temp.</p> <p>Measure OD air temperature then compare with D-checker data. Obviously different?</p> <p>YES → Replace failed sensor if necessary.</p> <p>NO</p> <p>Measure liquid tubing temp beside of OD liquid thermistor then compare with D-checker data. Obviously different?</p> <p>YES → Replace failed sensor if necessary.</p> <p>NO → Install thermal insulation onto liquid tubing exposed to outdoor to keep warm.</p>	
Diagnosis	Corrective Actions						
<p><b>Cooling</b></p> <p>Is amount of charge correct? SH is proper?</p> <p>NO → Adjust charge per IO manual.</p> <p>YES → Check any clogging in refrigerant circuit.</p>							
<p><b>Heating</b></p> <p>For compressor wiring, any open circuit or connected to a wrong terminal?</p> <p>YES → Fix the wiring issue.</p> <p>NO</p> <p>Is amount of charge correct? SH is proper?</p> <p>NO → Adjust charge per IO manual.</p> <p>YES</p> <p>Clogging refrigerant circuit?</p> <p>YES → Resolve the clogging.</p> <p>NO</p> <p>Check D-checker data</p> <p>Other → Replace OD unit PCB.</p> <p>Disch temp. - Cond temp. &gt; 75°C (135°F)</p> <p>Measure discharge temp and high pressure then compare with D-checker data. Obviously different?</p> <p>YES → Replace failed sensor if necessary.</p> <p>NO → Replace OD unit PCB.</p> <p><b>&amp;</b> [ 3.5 - 5.0 ton models and 3.0 - 4.0 ton Enhanced Capacity/High Efficiency models Outdoor air temp. - 2°C (4°F) &gt; Liquid pipe temp.</p> <p>Measure OD air temperature then compare with D-checker data. Obviously different?</p> <p>YES → Replace failed sensor if necessary.</p> <p>NO</p> <p>Measure liquid tubing temp beside of OD liquid thermistor then compare with D-checker data. Obviously different?</p> <p>YES → Replace failed sensor if necessary.</p> <p>NO → Install thermal insulation onto liquid tubing exposed to outdoor to keep warm.</p>							
<h3>3 Error Decision Conditions</h3> <p><b>[Cooling]</b> When evaporating pressure is excessive low.</p> <p><b>[Heating]</b> When discharge SH is high or liquid pipe temp is low.</p>							
<h3>4 Supposed Causes</h3> <ul style="list-style-type: none"> <li>● Refrigerant leak</li> <li>● Low refrigerant charge</li> <li>● Thermistors inoperable or not properly connected</li> <li>● Pressure sensor inoperable or not properly connected</li> <li>● Wrong compressor wiring</li> <li>● Closing stop valve</li> <li>● Clogged refrigerant circuit</li> </ul>							

Error Code <b>E44</b>	<b>Outdoor temperature outside of range</b>
--------------------------	---

<h3>1 Applicable Models</h3> <p>Outdoor AC Outdoor HP</p>	<h3>5. Troubleshooting</h3>					
<h3>2 Method of Error Detection</h3> <p>OD outdoor air thermistor</p>	<table border="1" style="width: 100%;"> <thead> <tr> <th style="width: 50%;">Diagnosis</th> <th style="width: 50%;">Corrective Actions</th> </tr> </thead> <tbody> <tr> <td> <div style="border: 1px solid black; padding: 5px;">                     Actual outdoor temperature                     <div style="float: right; margin-top: -15px;">Other →</div> </div> </td> <td>Move to <b>[A]</b>.</td> </tr> <tr> <td> <div style="border: 1px solid black; padding: 5px;">                     or                     <div style="display: inline-block; vertical-align: middle; margin-left: 10px;">                         &amp;                         <div style="display: inline-block; vertical-align: middle; margin-left: 5px;">                             Cooling mode                             <div style="display: inline-block; vertical-align: middle; margin-left: 5px;">                                 or                                 <div style="display: inline-block; vertical-align: middle; margin-left: 5px;">                                     Outdoor temperature &gt; 55°C (131°F)                                 </div> </div> </div> </div> </div> </td></tr></tbody></table>	Diagnosis	Corrective Actions	<div style="border: 1px solid black; padding: 5px;">                     Actual outdoor temperature                     <div style="float: right; margin-top: -15px;">Other →</div> </div>	Move to <b>[A]</b> .	<div style="border: 1px solid black; padding: 5px;">                     or                     <div style="display: inline-block; vertical-align: middle; margin-left: 10px;">                         &amp;                         <div style="display: inline-block; vertical-align: middle; margin-left: 5px;">                             Cooling mode                             <div style="display: inline-block; vertical-align: middle; margin-left: 5px;">                                 or                                 <div style="display: inline-block; vertical-align: middle; margin-left: 5px;">                                     Outdoor temperature &gt; 55°C (131°F)                                 </div> </div> </div> </div> </div>
Diagnosis	Corrective Actions					
<div style="border: 1px solid black; padding: 5px;">                     Actual outdoor temperature                     <div style="float: right; margin-top: -15px;">Other →</div> </div>	Move to <b>[A]</b> .					
<div style="border: 1px solid black; padding: 5px;">                     or                     <div style="display: inline-block; vertical-align: middle; margin-left: 10px;">                         &amp;                         <div style="display: inline-block; vertical-align: middle; margin-left: 5px;">                             Cooling mode                             <div style="display: inline-block; vertical-align: middle; margin-left: 5px;">                                 or                                 <div style="display: inline-block; vertical-align: middle; margin-left: 5px;">                                     Outdoor temperature &gt; 55°C (131°F)                                 </div> </div> </div> </div> </div>						

Error Code

# E57

## Refrigerant cooling sweat error

### 1 Applicable Models

Outdoor HP 3.5 - 5.0 ton  
Outdoor Enhanced HP 3.0 - 4.0 ton

### 2 Method of Error Detection

Detected by outdoor liquid temperature.

### 3 Error Decision Conditions

When liquid pipe temperature is less than outdoor temperature minus 2°C (3.6°F) for continuous 420 seconds or less than outdoor temperature minus 5°C (9°F) for continuous 100 seconds during heating operation.

### 4 Supposed Causes

- Refrigerant Leak
- Low refrigerant charge
- Faulty indoor EEV or indoor EEV coil
- Thermistors inoperable or improper connection

### 5. Troubleshooting

Diagnosis	Corrective Actions
<p>Charge amount of refrigerant is correct?</p> <p>NO →</p> <p>YES ↓</p>	<p>Check refrigerant leak. Charge refrigerant correctly.</p> <p>Connect properly.</p> <p>Attach EEV coil properly.</p> <p>Replace EEV coil.</p> <p>Connect properly.</p> <p>Replace thermistor.</p> <p>Replace PCB.</p>
<p>Indoor EEV coil is connected to PCB properly?</p> <p>NO →</p> <p>YES ↓</p>	
<p>Indoor and outdoor EEV coils are attached to EEV body properly? (*1)</p> <p>NO →</p> <p>YES ↓</p>	
<p>Coil resistance of EEV is normal?</p> <p>NO →</p> <p>YES ↓</p>	
<p>Outdoor liquid thermistor is connected properly?</p> <p>NO →</p> <p>YES ↓</p>	
<p>Characteristic of outdoor liquid thermistor is normal?</p> <p>NO →</p> <p>YES →</p>	

\*1: Check if EEV coil is correctly secured to EEV body. Protrusion on EEV coil should be clicked into place on dimple of EEV body.

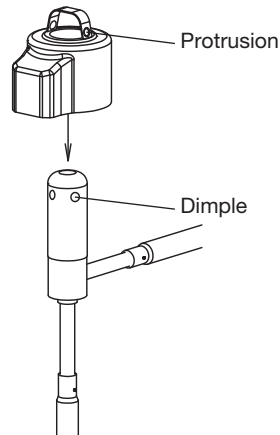

Error Code <h1 style="margin: 0;">E58</h1>	<h2 style="margin: 0;">Overload protection sensor open error</h2>
---	---

<h3 style="margin: 0;">1 Applicable Models</h3> <p style="margin: 5px 0;">Outdoor AC Outdoor HP</p>	<h3 style="margin: 0;">5. Troubleshooting</h3> <table border="1" style="width: 100%; border-collapse: collapse;"> <thead> <tr> <th style="width: 60%; padding: 5px;">Diagnosis</th> <th style="width: 40%; padding: 5px;">Corrective Actions</th> </tr> </thead> <tbody> <tr> <td style="padding: 5px; text-align: center;"> <div style="display: flex; justify-content: center; align-items: center;"> <div style="border: 1px solid black; width: 150px; height: 30px; margin: 0 auto 10px auto;"></div> <div style="text-align: left; margin-left: 10px;">                     OL is connected to PCB properly?                 </div> </div> <div style="display: flex; justify-content: space-between; margin-left: 100px;"> <span>NO</span> <span>→</span> </div> <div style="display: flex; justify-content: center; align-items: center; margin: 5px 0;"> <div style="border: 1px solid black; width: 30px; height: 15px; margin: 0 auto;"></div> <div style="text-align: left; margin-left: 5px;">                     YES                 </div> </div> <div style="display: flex; justify-content: center; align-items: center;"> <div style="border: 1px solid black; width: 150px; height: 30px; margin: 0 auto 10px auto;"></div> <div style="text-align: left; margin-left: 10px;">                     OL switch is opened?                 </div> </div> <div style="display: flex; justify-content: space-between; margin-left: 100px;"> <span>NO</span> <span>→</span> </div> <div style="display: flex; justify-content: center; align-items: center; margin: 5px 0;"> <div style="border: 1px solid black; width: 30px; height: 15px; margin: 0 auto;"></div> <div style="text-align: left; margin-left: 5px;">                     YES                 </div> </div> <div style="display: flex; justify-content: space-between; margin-left: 100px;"> <span>→</span> <span>→</span> </div> </td> <td style="padding: 5px; vertical-align: top;"> <p style="margin: 0;">Connect properly.</p> <p style="margin: 0;">Replace PCB.</p> <p style="margin: 0;">Replace OL switch.</p> </td> </tr> </tbody> </table>	Diagnosis	Corrective Actions	<div style="display: flex; justify-content: center; align-items: center;"> <div style="border: 1px solid black; width: 150px; height: 30px; margin: 0 auto 10px auto;"></div> <div style="text-align: left; margin-left: 10px;">                     OL is connected to PCB properly?                 </div> </div> <div style="display: flex; justify-content: space-between; margin-left: 100px;"> <span>NO</span> <span>→</span> </div> <div style="display: flex; justify-content: center; align-items: center; margin: 5px 0;"> <div style="border: 1px solid black; width: 30px; height: 15px; margin: 0 auto;"></div> <div style="text-align: left; margin-left: 5px;">                     YES                 </div> </div> <div style="display: flex; justify-content: center; align-items: center;"> <div style="border: 1px solid black; width: 150px; height: 30px; margin: 0 auto 10px auto;"></div> <div style="text-align: left; margin-left: 10px;">                     OL switch is opened?                 </div> </div> <div style="display: flex; justify-content: space-between; margin-left: 100px;"> <span>NO</span> <span>→</span> </div> <div style="display: flex; justify-content: center; align-items: center; margin: 5px 0;"> <div style="border: 1px solid black; width: 30px; height: 15px; margin: 0 auto;"></div> <div style="text-align: left; margin-left: 5px;">                     YES                 </div> </div> <div style="display: flex; justify-content: space-between; margin-left: 100px;"> <span>→</span> <span>→</span> </div>	<p style="margin: 0;">Connect properly.</p> <p style="margin: 0;">Replace PCB.</p> <p style="margin: 0;">Replace OL switch.</p>
Diagnosis	Corrective Actions				
<div style="display: flex; justify-content: center; align-items: center;"> <div style="border: 1px solid black; width: 150px; height: 30px; margin: 0 auto 10px auto;"></div> <div style="text-align: left; margin-left: 10px;">                     OL is connected to PCB properly?                 </div> </div> <div style="display: flex; justify-content: space-between; margin-left: 100px;"> <span>NO</span> <span>→</span> </div> <div style="display: flex; justify-content: center; align-items: center; margin: 5px 0;"> <div style="border: 1px solid black; width: 30px; height: 15px; margin: 0 auto;"></div> <div style="text-align: left; margin-left: 5px;">                     YES                 </div> </div> <div style="display: flex; justify-content: center; align-items: center;"> <div style="border: 1px solid black; width: 150px; height: 30px; margin: 0 auto 10px auto;"></div> <div style="text-align: left; margin-left: 10px;">                     OL switch is opened?                 </div> </div> <div style="display: flex; justify-content: space-between; margin-left: 100px;"> <span>NO</span> <span>→</span> </div> <div style="display: flex; justify-content: center; align-items: center; margin: 5px 0;"> <div style="border: 1px solid black; width: 30px; height: 15px; margin: 0 auto;"></div> <div style="text-align: left; margin-left: 5px;">                     YES                 </div> </div> <div style="display: flex; justify-content: space-between; margin-left: 100px;"> <span>→</span> <span>→</span> </div>	<p style="margin: 0;">Connect properly.</p> <p style="margin: 0;">Replace PCB.</p> <p style="margin: 0;">Replace OL switch.</p>				
<h3 style="margin: 0;">2 Method of Error Detection</h3> <p style="margin: 5px 0;">Detected by continuity of OL switch.</p>					
<h3 style="margin: 0;">3 Error Decision Conditions</h3> <p style="margin: 5px 0;">When there is no continuity in OL switch at the start of compressor operation.</p>					
<h3 style="margin: 0;">4 Supposed Causes</h3> <ul style="list-style-type: none"> <li>● Overload protection (OL) switch inoperable</li> </ul>					

Error Code

# Ed2

## System mismatch

### 1 Applicable Models

Outdoor AC  
Outdoor HP

### 2 Method of Error Detection

Communication data from indoor unit

### 3 Error Decision Conditions

When required CFM exceeds maximum CFM limit of the indoor unit.

When a connected indoor unit is not EEV type.

### 4 Supposed Causes

- Airflow trim setting is set to prohibited setting value.
- Uncertified indoor unit have been connected.

### 5. Troubleshooting

#### Diagnosis

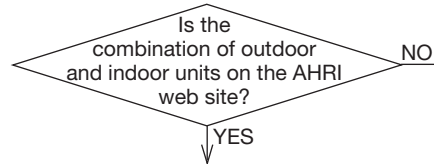

Make sure the airflow trim setting have not set to prohibited value.

Outdoor Unit	GXV6S*361*A* GZV6S*361*A*	Trim more than 10% settings are invalid. Trimmed up CFM makes mismatch error.
Indoor Unit	G*VT960403B / 0603B G*VM970603B G*VT800603B / 0803B MBVK12BP G*VS960603BU	
Outdoor Unit	GXV6S*601*A* GZV6S*601*A* GZV7S*421*A* GZV7S*481*A* GXV9S*481*A*	Trim more than 5% settings are invalid. Trimmed up CFM makes mismatch error.
Indoor Unit	G*VT960804C G*VM970804C G*VT800804C	

#### Corrective Actions

Replace to certified combination.

Error Code <b>b9</b>	<b>Low indoor airflow (without electric heat mode)</b>
-------------------------	--

<h3>1 Applicable Models</h3> <p>EEV air handler</p>	<h3>5. Troubleshooting</h3> <table border="1" style="width: 100%;"> <thead> <tr> <th style="width: 50%;">Diagnosis</th> <th style="width: 50%;">Corrective Actions</th> </tr> </thead> <tbody> <tr> <td colspan="2"> <p><b>⚠ CAUTION</b>                      Be sure to turn off the power switch before connecting or disconnecting connectors, or parts may be damaged.</p> </td> </tr> <tr> <td style="text-align: center;"> <p>Obstacles are touching the blower/motor, or blocked filters?</p> <p>YES →</p> <p>NO ↓</p> </td> <td style="vertical-align: top;"> <p>Remove obstacles from a blower/motor or filters.</p> </td> </tr> <tr> <td style="text-align: center;"> <p>Blockage in the airflow (duct work)?</p> <p>YES →</p> <p>NO ↓</p> </td> <td style="vertical-align: top;"> <p>Remove obstacles from the duct.</p> </td> </tr> <tr> <td style="text-align: center;"> <p>Ducts are undersized. External static pressure is more than 0.9 inH<sub>2</sub>O (224 Pa)?</p> <p>YES →</p> <p>NO ↓</p> </td> <td style="vertical-align: top;"> <p>Redesign the duct so that the external static pressure is less than 0.9 inH<sub>2</sub>O (224 Pa).</p> </td> </tr> <tr> <td style="text-align: center;"> <p>NO →</p> </td> <td style="vertical-align: top;"> <p>Replace control board or motor.</p> </td> </tr> </tbody> </table>	Diagnosis	Corrective Actions	<p><b>⚠ CAUTION</b>                      Be sure to turn off the power switch before connecting or disconnecting connectors, or parts may be damaged.</p>		<p>Obstacles are touching the blower/motor, or blocked filters?</p> <p>YES →</p> <p>NO ↓</p>	<p>Remove obstacles from a blower/motor or filters.</p>	<p>Blockage in the airflow (duct work)?</p> <p>YES →</p> <p>NO ↓</p>	<p>Remove obstacles from the duct.</p>	<p>Ducts are undersized. External static pressure is more than 0.9 inH<sub>2</sub>O (224 Pa)?</p> <p>YES →</p> <p>NO ↓</p>	<p>Redesign the duct so that the external static pressure is less than 0.9 inH<sub>2</sub>O (224 Pa).</p>	<p>NO →</p>	<p>Replace control board or motor.</p>
Diagnosis	Corrective Actions												
<p><b>⚠ CAUTION</b>                      Be sure to turn off the power switch before connecting or disconnecting connectors, or parts may be damaged.</p>													
<p>Obstacles are touching the blower/motor, or blocked filters?</p> <p>YES →</p> <p>NO ↓</p>	<p>Remove obstacles from a blower/motor or filters.</p>												
<p>Blockage in the airflow (duct work)?</p> <p>YES →</p> <p>NO ↓</p>	<p>Remove obstacles from the duct.</p>												
<p>Ducts are undersized. External static pressure is more than 0.9 inH<sub>2</sub>O (224 Pa)?</p> <p>YES →</p> <p>NO ↓</p>	<p>Redesign the duct so that the external static pressure is less than 0.9 inH<sub>2</sub>O (224 Pa).</p>												
<p>NO →</p>	<p>Replace control board or motor.</p>												
<h3>2 Method of Error Detection</h3> <p>Number of revolutions of the blower motor</p>													
<h3>3 Error Decision Conditions</h3> <p>When no EH demand is active and the below conditions.</p> <ul style="list-style-type: none"> <li>● When the following status is detected for 10 times consecutively  <math>50 \text{ rpm} &lt; \text{Feedback rpm} \leq \text{Min rpm}</math>                      (150 rpm)</li> </ul> <p style="text-align: center;">OR</p> <ul style="list-style-type: none"> <li>● When the above condition is detected 360 times while checking 720 times.</li> </ul>													
<h3>4 Supposed Causes</h3> <ul style="list-style-type: none"> <li>● Fan/motor obstruction or blocked filters</li> <li>● Restrictive ductwork or ductwork undersized</li> <li>● ID motor or control board failure</li> </ul>													

Error Code

# 9b

## Low indoor airflow (with electric heat mode)

### 1 Applicable Models

EEV air handler

### 2 Method of Error Detection

Number of revolutions of the blower motor

### 3 Error Decision Conditions

When EH demand is active and the below conditions.

- When the following status is detected for 10 times consecutively  
 $50 \text{ rpm} < \text{Feedback rpm} \leq \text{Min rpm}$   
 (150 rpm)
- OR
- When the above condition is detected 360 times while checking 720 times.

### 4 Supposed Causes

- Fan/motor obstruction or blocked filters
- Restrictive ductwork or ductwork undersized
- ID motor or control board failure

### 5. Troubleshooting

#### Diagnosis

#### Corrective Actions

#### CAUTION

Be sure to turn off the power switch before connecting or disconnecting connectors, or parts may be damaged.

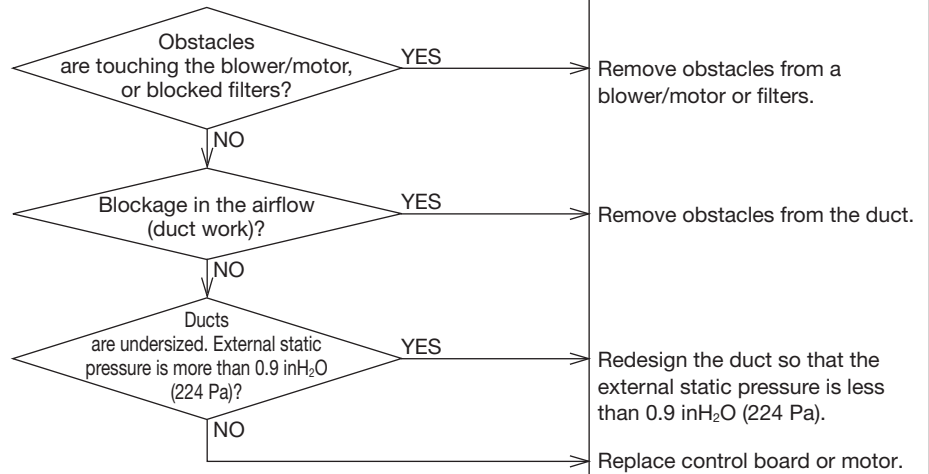

Error Code <h1 style="font-size: 2em;">70</h1>	<h2>EEV disconnection detected</h2>
---	-------------------------------------

<h3>1 Applicable Models</h3> <p>EEV air handler EEV cased coil</p>	<h3>5. Troubleshooting</h3>																																
<h3>2 Method of Error Detection</h3> <p>Check Indoor EEV coil connection (X3A)</p>	<table border="1" style="width: 100%;"> <thead> <tr> <th style="text-align: center;">Diagnosis</th> <th style="text-align: center;">Corrective Actions</th> </tr> </thead> <tbody> <tr> <td colspan="2"> <p><b>⚠ CAUTION</b> Be sure to turn off the power switch before connecting or disconnecting connectors, or parts may be damaged.</p> </td> </tr> <tr> <td colspan="2" style="text-align: center;"> </td> </tr> <tr> <td colspan="2"> <p>*1: EEV coil connector</p> <table style="display: inline-table; vertical-align: middle;"> <tr> <td style="text-align: right;">Orange (1)</td> <td>○</td> <td rowspan="6" style="text-align: center;"> </td> </tr> <tr> <td style="text-align: right;">Red (2)</td> <td>○</td> </tr> <tr> <td style="text-align: right;">Yellow (3)</td> <td>○</td> </tr> <tr> <td style="text-align: right;">Black (4)</td> <td>○</td> </tr> <tr> <td style="text-align: right;">— (5)</td> <td>○</td> </tr> <tr> <td style="text-align: right;">COM[+] Gray (6)</td> <td>○</td> </tr> </table> <table border="1" style="display: inline-table; vertical-align: middle; margin-left: 20px;"> <thead> <tr> <th style="text-align: center;">Measuring points</th> <th style="text-align: center;">Judgment criteria</th> </tr> </thead> <tbody> <tr> <td style="text-align: center;">1 - 6</td> <td rowspan="4" style="text-align: center;">40-50 Ω</td> </tr> <tr> <td style="text-align: center;">2 - 6</td> </tr> <tr> <td style="text-align: center;">3 - 6</td> </tr> <tr> <td style="text-align: center;">4 - 6</td> </tr> </tbody> </table> </td> </tr> <tr> <td style="vertical-align: top;"> <h3>3 Error Decision Conditions</h3> <p>EEV connector not detected</p> </td> <td style="vertical-align: top;"> </td> </tr> <tr> <td style="vertical-align: top;"> <h3>4 Supposed Causes</h3> <ul style="list-style-type: none"> <li>● Indoor EEV coil not connected (control board and junction connector)</li> <li>● Incorrect wiring to EEV</li> <li>● ID control board failure</li> </ul> </td> <td style="vertical-align: top;"> </td> </tr> </tbody></table>	Diagnosis	Corrective Actions	<p><b>⚠ CAUTION</b> Be sure to turn off the power switch before connecting or disconnecting connectors, or parts may be damaged.</p>				<p>*1: EEV coil connector</p> <table style="display: inline-table; vertical-align: middle;"> <tr> <td style="text-align: right;">Orange (1)</td> <td>○</td> <td rowspan="6" style="text-align: center;"> </td> </tr> <tr> <td style="text-align: right;">Red (2)</td> <td>○</td> </tr> <tr> <td style="text-align: right;">Yellow (3)</td> <td>○</td> </tr> <tr> <td style="text-align: right;">Black (4)</td> <td>○</td> </tr> <tr> <td style="text-align: right;">— (5)</td> <td>○</td> </tr> <tr> <td style="text-align: right;">COM[+] Gray (6)</td> <td>○</td> </tr> </table> <table border="1" style="display: inline-table; vertical-align: middle; margin-left: 20px;"> <thead> <tr> <th style="text-align: center;">Measuring points</th> <th style="text-align: center;">Judgment criteria</th> </tr> </thead> <tbody> <tr> <td style="text-align: center;">1 - 6</td> <td rowspan="4" style="text-align: center;">40-50 Ω</td> </tr> <tr> <td style="text-align: center;">2 - 6</td> </tr> <tr> <td style="text-align: center;">3 - 6</td> </tr> <tr> <td style="text-align: center;">4 - 6</td> </tr> </tbody> </table>		Orange (1)	○		Red (2)	○	Yellow (3)	○	Black (4)	○	— (5)	○	COM[+] Gray (6)	○	Measuring points	Judgment criteria	1 - 6	40-50 Ω	2 - 6	3 - 6	4 - 6	<h3>3 Error Decision Conditions</h3> <p>EEV connector not detected</p>		<h3>4 Supposed Causes</h3> <ul style="list-style-type: none"> <li>● Indoor EEV coil not connected (control board and junction connector)</li> <li>● Incorrect wiring to EEV</li> <li>● ID control board failure</li> </ul>	
Diagnosis	Corrective Actions																																
<p><b>⚠ CAUTION</b> Be sure to turn off the power switch before connecting or disconnecting connectors, or parts may be damaged.</p>																																	
<p>*1: EEV coil connector</p> <table style="display: inline-table; vertical-align: middle;"> <tr> <td style="text-align: right;">Orange (1)</td> <td>○</td> <td rowspan="6" style="text-align: center;"> </td> </tr> <tr> <td style="text-align: right;">Red (2)</td> <td>○</td> </tr> <tr> <td style="text-align: right;">Yellow (3)</td> <td>○</td> </tr> <tr> <td style="text-align: right;">Black (4)</td> <td>○</td> </tr> <tr> <td style="text-align: right;">— (5)</td> <td>○</td> </tr> <tr> <td style="text-align: right;">COM[+] Gray (6)</td> <td>○</td> </tr> </table> <table border="1" style="display: inline-table; vertical-align: middle; margin-left: 20px;"> <thead> <tr> <th style="text-align: center;">Measuring points</th> <th style="text-align: center;">Judgment criteria</th> </tr> </thead> <tbody> <tr> <td style="text-align: center;">1 - 6</td> <td rowspan="4" style="text-align: center;">40-50 Ω</td> </tr> <tr> <td style="text-align: center;">2 - 6</td> </tr> <tr> <td style="text-align: center;">3 - 6</td> </tr> <tr> <td style="text-align: center;">4 - 6</td> </tr> </tbody> </table>		Orange (1)	○		Red (2)	○	Yellow (3)	○	Black (4)	○	— (5)		○	COM[+] Gray (6)	○	Measuring points	Judgment criteria	1 - 6	40-50 Ω	2 - 6	3 - 6	4 - 6											
Orange (1)	○																																
Red (2)	○																																
Yellow (3)	○																																
Black (4)	○																																
— (5)	○																																
COM[+] Gray (6)	○																																
Measuring points	Judgment criteria																																
1 - 6	40-50 Ω																																
2 - 6																																	
3 - 6																																	
4 - 6																																	
<h3>3 Error Decision Conditions</h3> <p>EEV connector not detected</p>																																	
<h3>4 Supposed Causes</h3> <ul style="list-style-type: none"> <li>● Indoor EEV coil not connected (control board and junction connector)</li> <li>● Incorrect wiring to EEV</li> <li>● ID control board failure</li> </ul>																																	

Error Code

# 73

## Liquid side thermistor abnormality

### 1 Applicable Models

EEV air handler  
EEV cased coil

### 2 Method of Error Detection

Check indoor thermistor resistance value  
(X5A, 3 and 4 pin)

### 3 Error Decision Conditions

- Open or short circuit of the thermistor
- When thermistor detects about less than  $-43.6^{\circ}\text{C}$  ( $-46.48^{\circ}\text{F}$ ) or more than  $90^{\circ}\text{C}$  ( $194^{\circ}\text{F}$ ) for continuous 20 seconds.
  - When thermistor resistance is less than  $1342\ \Omega$  or more than  $1.7\ \text{M}\Omega$ .

### 4 Supposed Causes

- Open or short circuit of the liquid thermistor (X5A)
- Liquid thermistor reading incorrect or values outside the normal range
- ID control board failure

### 5. Troubleshooting

#### Diagnosis

#### Corrective Actions



#### CAUTION

Be sure to turn off the power switch before connecting or disconnecting connectors, or parts may be damaged.

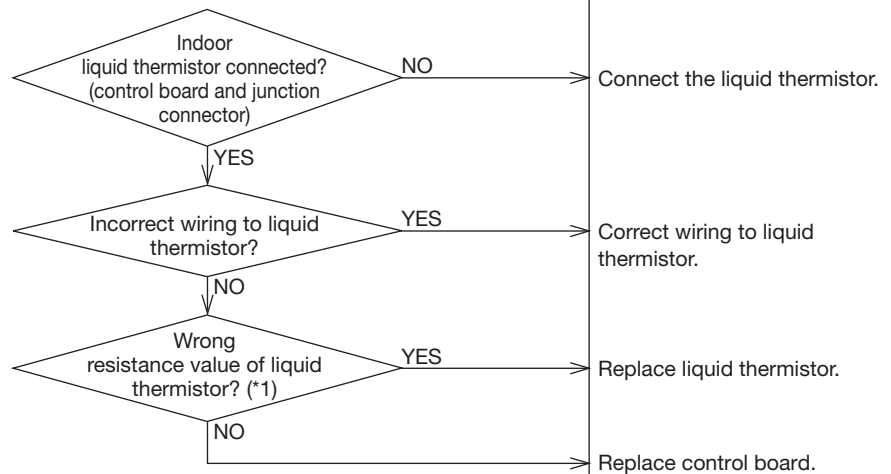

\*1: Resistance value

TEMP	TEMP	Thermistor Resistance	Volts	TEMP	TEMP	Thermistor Resistance	Volts
$^{\circ}\text{C}$	$^{\circ}\text{F}$	k $\Omega$	VDC	$^{\circ}\text{C}$	$^{\circ}\text{F}$	k $\Omega$	VDC
-30	-22	364.43	4.58	65	149	4.16	0.56
-25	-13	267.00	4.45	70	158	3.50	0.48
-20	-4	197.81	4.29	75	167	2.96	0.41
-15	5	148.10	4.09	80	176	2.51	0.35
-10	14	111.99	3.86	85	185	2.14	0.30
-5	23	85.49	3.61	90	194	1.83	0.26
0	32	65.84	3.33	95	203	1.58	0.23
5	41	51.09	3.04	100	212	1.36	0.20
10	50	39.96	2.74	105	221	1.18	0.17
15	59	31.50	2.44	110	230	1.02	0.15
20	68	25.01	2.16	115	239	0.89	0.13
25	77	20.00	1.89	120	248	0.78	0.12
30	86	16.10	1.64	125	257	0.68	0.10
35	95	13.04	1.42	130	266	0.60	0.09
40	104	10.63	1.22	135	275	0.53	0.08
45	113	8.71	1.04	140	284	0.47	0.07
50	122	7.18	0.89	145	293	0.42	0.06
55	131	5.95	0.76	150	302	0.37	0.06
60	140	4.96	0.65				

Error Code <h1 style="font-size: 2em;">74</h1>	<h2 style="font-size: 1.2em;">Gas side thermistor abnormality</h2>
---	--

<h3>1 Applicable Models</h3>
EEV air handler EEV cased coil
<h3>2 Method of Error Detection</h3>
Check indoor thermistor resistance value (X5A, 1 and 2 pin)
<h3>3 Error Decision Conditions</h3>
Open or short circuit of the thermistor <ul style="list-style-type: none"> <li>● When thermistor detects about less than -43.6°C (-46.48°F) or more than 165°C (329°F) for continuous 20 seconds.</li> <li>● When output voltage is about less than 0.04 VDC.</li> <li>● When thermistor resistance is less than 309 Ω or more than 1.7 MΩ.</li> </ul>
<h3>4 Supposed Causes</h3>
<ul style="list-style-type: none"> <li>● Open or short circuit of the gas thermistor (X5A)</li> <li>● Gas thermistor reading incorrect or values outside the normal range</li> <li>● ID control board failure</li> </ul>

<h3>5. Troubleshooting</h3>																																																																																																																																																																									
<h4>Diagnosis</h4>	<h4>Corrective Actions</h4>																																																																																																																																																																								
<p><b>⚠ CAUTION</b>                  Be sure to turn off the power switch before connecting or disconnecting connectors, or parts may be damaged.</p>																																																																																																																																																																									
<pre>                 graph TD                     A{Indoor gas thermistor connected? (control board and junction connector)} -- NO --&gt; B[Connect the gas thermistor.]                     A -- YES --&gt; C{Incorrect wiring to gas thermistor?}                     C -- YES --&gt; D[Correct wiring to gas thermistor.]                     C -- NO --&gt; E{Wrong resistance value of gas thermistor? (*1)}                     E -- YES --&gt; F[Replace gas thermistor.]                     E -- NO --&gt; G[Replace control board.]                 </pre>																																																																																																																																																																									
<p>*1: Resistance value</p> <table border="1" style="width: 100%; border-collapse: collapse; text-align: center;"> <thead> <tr> <th>TEMP</th><th>TEMP</th><th>Thermistor Resistance</th><th>Volts</th><th>TEMP</th><th>TEMP</th><th>Thermistor Resistance</th><th>Volts</th> </tr> <tr> <th>°C</th><th>°F</th><th>kΩ</th><th>VDC</th><th>°C</th><th>°F</th><th>kΩ</th><th>VDC</th> </tr> </thead> <tbody> <tr><td>-30</td><td>-22</td><td>364.43</td><td>4.58</td><td>65</td><td>149</td><td>4.16</td><td>0.56</td></tr> <tr><td>-25</td><td>-13</td><td>267.00</td><td>4.45</td><td>70</td><td>158</td><td>3.50</td><td>0.48</td></tr> <tr><td>-20</td><td>-4</td><td>197.81</td><td>4.29</td><td>75</td><td>167</td><td>2.96</td><td>0.41</td></tr> <tr><td>-15</td><td>5</td><td>148.10</td><td>4.09</td><td>80</td><td>176</td><td>2.51</td><td>0.35</td></tr> <tr><td>-10</td><td>14</td><td>111.99</td><td>3.86</td><td>85</td><td>185</td><td>2.14</td><td>0.30</td></tr> <tr><td>-5</td><td>23</td><td>85.49</td><td>3.61</td><td>90</td><td>194</td><td>1.83</td><td>0.26</td></tr> <tr><td>0</td><td>32</td><td>65.84</td><td>3.33</td><td>95</td><td>203</td><td>1.58</td><td>0.23</td></tr> <tr><td>5</td><td>41</td><td>51.09</td><td>3.04</td><td>100</td><td>212</td><td>1.36</td><td>0.20</td></tr> <tr><td>10</td><td>50</td><td>39.96</td><td>2.74</td><td>105</td><td>221</td><td>1.18</td><td>0.17</td></tr> <tr><td>15</td><td>59</td><td>31.50</td><td>2.44</td><td>110</td><td>230</td><td>1.02</td><td>0.15</td></tr> <tr><td>20</td><td>68</td><td>25.01</td><td>2.16</td><td>115</td><td>239</td><td>0.89</td><td>0.13</td></tr> <tr><td>25</td><td>77</td><td>20.00</td><td>1.89</td><td>120</td><td>248</td><td>0.78</td><td>0.12</td></tr> <tr><td>30</td><td>86</td><td>16.10</td><td>1.64</td><td>125</td><td>257</td><td>0.68</td><td>0.10</td></tr> <tr><td>35</td><td>95</td><td>13.04</td><td>1.42</td><td>130</td><td>266</td><td>0.60</td><td>0.09</td></tr> <tr><td>40</td><td>104</td><td>10.63</td><td>1.22</td><td>135</td><td>275</td><td>0.53</td><td>0.08</td></tr> <tr><td>45</td><td>113</td><td>8.71</td><td>1.04</td><td>140</td><td>284</td><td>0.47</td><td>0.07</td></tr> <tr><td>50</td><td>122</td><td>7.18</td><td>0.89</td><td>145</td><td>293</td><td>0.42</td><td>0.06</td></tr> <tr><td>55</td><td>131</td><td>5.95</td><td>0.76</td><td>150</td><td>302</td><td>0.37</td><td>0.06</td></tr> <tr><td>60</td><td>140</td><td>4.96</td><td>0.65</td><td></td><td></td><td></td><td></td></tr> </tbody> </table>		TEMP	TEMP	Thermistor Resistance	Volts	TEMP	TEMP	Thermistor Resistance	Volts	°C	°F	kΩ	VDC	°C	°F	kΩ	VDC	-30	-22	364.43	4.58	65	149	4.16	0.56	-25	-13	267.00	4.45	70	158	3.50	0.48	-20	-4	197.81	4.29	75	167	2.96	0.41	-15	5	148.10	4.09	80	176	2.51	0.35	-10	14	111.99	3.86	85	185	2.14	0.30	-5	23	85.49	3.61	90	194	1.83	0.26	0	32	65.84	3.33	95	203	1.58	0.23	5	41	51.09	3.04	100	212	1.36	0.20	10	50	39.96	2.74	105	221	1.18	0.17	15	59	31.50	2.44	110	230	1.02	0.15	20	68	25.01	2.16	115	239	0.89	0.13	25	77	20.00	1.89	120	248	0.78	0.12	30	86	16.10	1.64	125	257	0.68	0.10	35	95	13.04	1.42	130	266	0.60	0.09	40	104	10.63	1.22	135	275	0.53	0.08	45	113	8.71	1.04	140	284	0.47	0.07	50	122	7.18	0.89	145	293	0.42	0.06	55	131	5.95	0.76	150	302	0.37	0.06	60	140	4.96	0.65				
TEMP	TEMP	Thermistor Resistance	Volts	TEMP	TEMP	Thermistor Resistance	Volts																																																																																																																																																																		
°C	°F	kΩ	VDC	°C	°F	kΩ	VDC																																																																																																																																																																		
-30	-22	364.43	4.58	65	149	4.16	0.56																																																																																																																																																																		
-25	-13	267.00	4.45	70	158	3.50	0.48																																																																																																																																																																		
-20	-4	197.81	4.29	75	167	2.96	0.41																																																																																																																																																																		
-15	5	148.10	4.09	80	176	2.51	0.35																																																																																																																																																																		
-10	14	111.99	3.86	85	185	2.14	0.30																																																																																																																																																																		
-5	23	85.49	3.61	90	194	1.83	0.26																																																																																																																																																																		
0	32	65.84	3.33	95	203	1.58	0.23																																																																																																																																																																		
5	41	51.09	3.04	100	212	1.36	0.20																																																																																																																																																																		
10	50	39.96	2.74	105	221	1.18	0.17																																																																																																																																																																		
15	59	31.50	2.44	110	230	1.02	0.15																																																																																																																																																																		
20	68	25.01	2.16	115	239	0.89	0.13																																																																																																																																																																		
25	77	20.00	1.89	120	248	0.78	0.12																																																																																																																																																																		
30	86	16.10	1.64	125	257	0.68	0.10																																																																																																																																																																		
35	95	13.04	1.42	130	266	0.60	0.09																																																																																																																																																																		
40	104	10.63	1.22	135	275	0.53	0.08																																																																																																																																																																		
45	113	8.71	1.04	140	284	0.47	0.07																																																																																																																																																																		
50	122	7.18	0.89	145	293	0.42	0.06																																																																																																																																																																		
55	131	5.95	0.76	150	302	0.37	0.06																																																																																																																																																																		
60	140	4.96	0.65																																																																																																																																																																						

Error Code

# 75

## Pressure sensor abnormality

### 1 Applicable Models

EEV air handler  
EEV cased coil

### 2 Method of Error Detection

Check indoor pressure sensor voltage value  
(X15A, 3 and 1 pin)

### 3 Error Decision Conditions

Open or short circuit of the pressure sensor

- When sensor detects less than -0.049 MPa (-7.11 PSIG) or more than 4.41 MPa (640 PSIG) for continuous 5 minutes.
- When output voltage is about less than 0.13 VDC or more than 4.63 VDC.

### 4 Supposed Causes

- Open or short circuit of the pressure sensor (X15A)
- Pressure sensor reading incorrect or values outside the normal range
- ID control board failure

### 5. Troubleshooting

#### Diagnosis

#### Corrective Actions



#### CAUTION

Be sure to turn off the power switch before connecting or disconnecting connectors, or parts may be damaged.

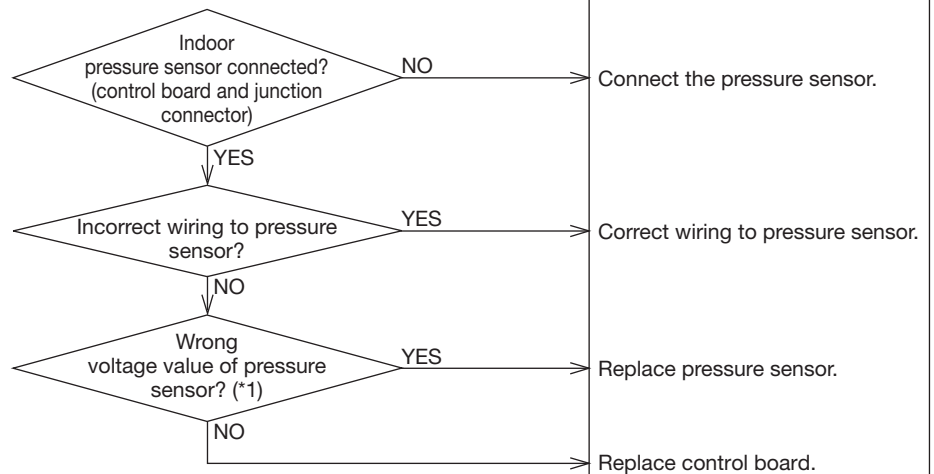

\*1: Voltage vs pressure characteristics between pins 3 (black) and 1 (white)

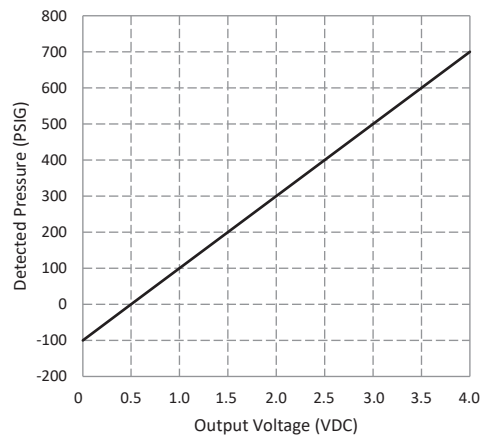

Error Code <h1 style="font-size: 2em;">76</h1>	<b>Indoor unit - outdoor unit, Gas furnace or blower unit communication error (during operation)</b>
---	--

<h3>1 Applicable Models</h3>
EEV cased coil
<h3>2 Method of Error Detection</h3>
Check communication error
<h3>3 Error Decision Conditions</h3>
When OD or ID drop off from node list after “system matching state”. (Error judgment time : The error is informed immediately after receiving latest node list.)
<h3>4 Supposed Causes</h3>
<ul style="list-style-type: none"> <li>● Open communication circuit</li> <li>● Incorrect wiring between OD unit, gas furnace or modular blower</li> <li>● No power supply to OD unit, gas furnace or modular blower.</li> <li>● Lost communication between Dragonfly board due to refrigerant leak detected</li> <li>● A2L sensor communication failure (Dragonfly board)</li> <li>● A2L sensor failure (Dragonfly board)</li> <li>● Control board failure</li> </ul>

<h3>5. Troubleshooting</h3>	
<h4>Diagnosis</h4>	<h4>Corrective Actions</h4>
<p><b>⚠ CAUTION</b>                  Be sure to turn off the power switch before connecting or disconnecting connectors, or parts may be damaged.</p>	
<p>(*1) Refer to Dragonfly's manual for its detailed actions.</p>	

Error Code

# 77

### Indoor unit – thermostat communication error (start-up & during operation)

#### 1 Applicable Models

EEV air handler  
EEV cased coil

#### 2 Method of Error Detection

Check communication connection

#### 3 Error Decision Conditions

When a thermostat cannot be recognized on a node list even if it passes for 60 seconds after a node list is received.

When receiving a node list newly during the above judgment, 60 seconds are recounted once again.

#### 4 Supposed Causes

- Incorrect wiring between ID unit and thermostat.  
The system may have the communication error without error code 77 on the indoor control board.
- Thermostat failure
- Power interruption (low voltage)
- Thermostat or control board failure

#### 5. Troubleshooting

##### Diagnosis

##### Corrective Actions

#### CAUTION

Be sure to turn off the power switch before connecting or disconnecting connectors, or parts may be damaged.

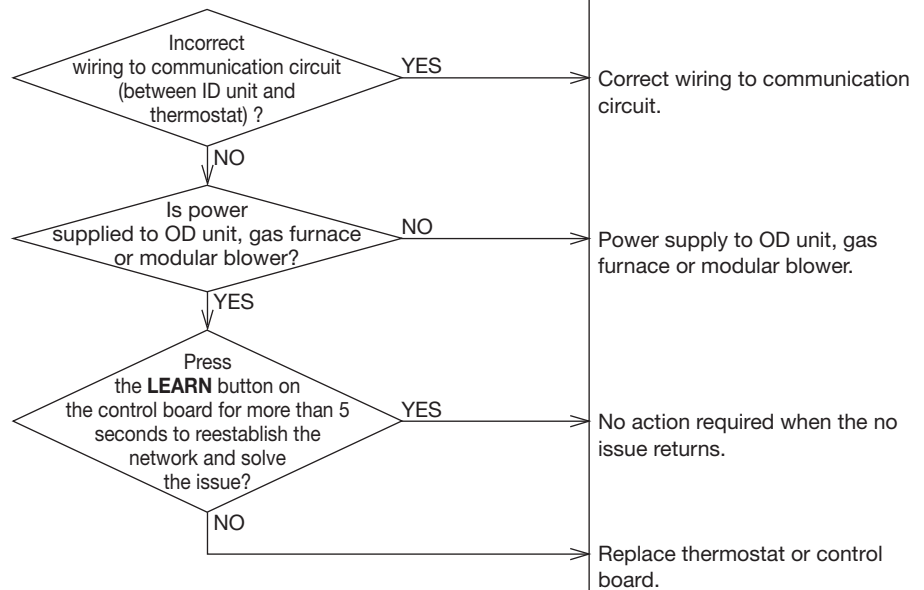

Error Code <b>78</b>	<b>Indoor unit - outdoor unit, gas furnace or blower unit communication error (startup operation)</b>
-------------------------	---

<h3>1 Applicable Models</h3> <p>EEV air handler EEV cased coil</p>	<h3>5. Troubleshooting</h3> <table border="1" style="width: 100%;"> <thead> <tr> <th style="width: 60%;">Diagnosis</th> <th style="width: 40%;">Corrective Actions</th> </tr> </thead> <tbody> <tr> <td colspan="2"> <p><b>⚠ CAUTION</b> Be sure to turn off the power switch before connecting or disconnecting connectors, or parts may be damaged.</p> </td> </tr> <tr> <td style="text-align: center;"> <p>Communication circuit connected?</p> <p>NO →</p> <p>YES ↓</p> </td> <td rowspan="3" style="vertical-align: top;"> <p>Connect the communication circuit.</p> </td> </tr> <tr> <td style="text-align: center;"> <p>Incorrect wiring to communication circuit ?</p> <p>YES →</p> <p>NO ↓</p> </td> </tr> <tr> <td style="text-align: center;"> <p>Is power supplied to OD unit, gas furnace or modular blower?</p> <p>NO →</p> <p>YES ↓</p> </td> </tr> <tr> <td colspan="2" style="text-align: right;"> <p>Correct wiring to communication circuit.</p> <p>Power supply to OD unit, gas furnace or modular blower.</p> <p>Replace control board.</p> </td> </tr> </tbody> </table>	Diagnosis	Corrective Actions	<p><b>⚠ CAUTION</b> Be sure to turn off the power switch before connecting or disconnecting connectors, or parts may be damaged.</p>		<p>Communication circuit connected?</p> <p>NO →</p> <p>YES ↓</p>	<p>Connect the communication circuit.</p>	<p>Incorrect wiring to communication circuit ?</p> <p>YES →</p> <p>NO ↓</p>	<p>Is power supplied to OD unit, gas furnace or modular blower?</p> <p>NO →</p> <p>YES ↓</p>	<p>Correct wiring to communication circuit.</p> <p>Power supply to OD unit, gas furnace or modular blower.</p> <p>Replace control board.</p>	
Diagnosis	Corrective Actions										
<p><b>⚠ CAUTION</b> Be sure to turn off the power switch before connecting or disconnecting connectors, or parts may be damaged.</p>											
<p>Communication circuit connected?</p> <p>NO →</p> <p>YES ↓</p>	<p>Connect the communication circuit.</p>										
<p>Incorrect wiring to communication circuit ?</p> <p>YES →</p> <p>NO ↓</p>											
<p>Is power supplied to OD unit, gas furnace or modular blower?</p> <p>NO →</p> <p>YES ↓</p>											
<p>Correct wiring to communication circuit.</p> <p>Power supply to OD unit, gas furnace or modular blower.</p> <p>Replace control board.</p>											
<h3>2 Method of Error Detection</h3> <p>Check communication connection</p>											
<h3>3 Error Decision Conditions</h3> <p>When the state never be “system matching state” from power ON. (Error judgment time : The error is informed keeping the error condition during 5 minutes after receiving latest node list. )</p>											
<h3>4 Supposed Causes</h3> <ul style="list-style-type: none"> <li>● Open communication circuit</li> <li>● Incorrect wiring between OD unit, gas furnace or modular blower</li> <li>● No power supply to OD unit, gas furnace or modular blower</li> <li>● Control board failure</li> </ul>											

Error Code

# A0

## Refrigerant Leakage Error

### 1 Applicable Models

EEV air handler  
A2L compatible gas furnace

### 2 Method of Error Detection

Refrigerant leak detected by A2L sensor

### 3 Error Decision Conditions

When an A2L sensor detects more than 7% LFL refrigerant leak.

When the unit is in the 5-min mitigation mode.

### 4 Supposed Causes

- Refrigerant Leaking
- Control board failure
- A2L sensor failure

### 5. Troubleshooting

#### Diagnosis

#### Corrective Actions



#### CAUTION

Be sure to turn off the power switch before connecting or disconnecting connectors, or parts may be damaged.

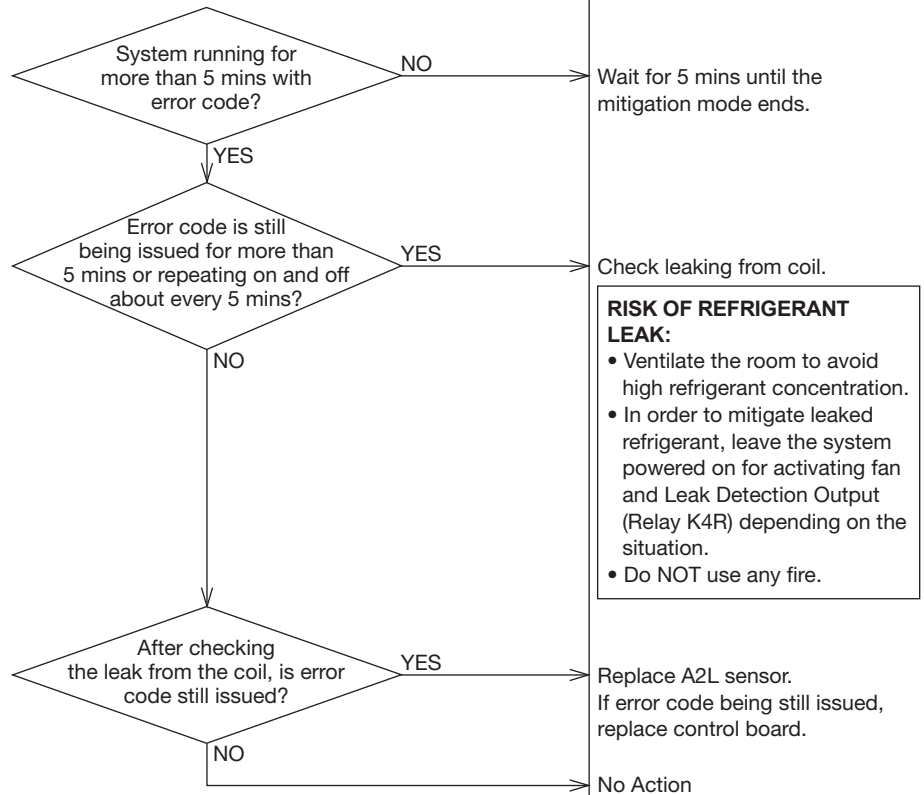

# TROUBLESHOOTING

## NETWORK TROUBLESHOOTING

If a network communication error code has occurred, use the following steps to help troubleshoot the system. (For network communication error codes, refer to the table below and the tables of error codes for outdoor unit and indoor unit.)

After any wiring changes have been made or DS1 dip switches on the outdoor unit control board have been changed, apply power to the system and see if the error codes have cleared.

1. Confirm low voltage wiring is correct per installation instructions. Check for miswiring. (i.e. Terminal 1 and 2 is reversed.)

**NOTE:** A removable plug connector is provided with the control to make thermostat wire connections. This plug may be removed, wire connections made to the plug, and replaced. It is **strongly** recommended that you do not connect more than two wires into a single terminal in the field because there is a risk of the wires becoming loose, which may result in intermittent operation.

2. Check wires for damage. (i.e. Broken wire at terminal, broken inside wire nuts or damaged cable between units.)
3. Perform continuity check on wires to make sure cable is OK. Replace the cable if necessary.
4. Change both dip switch 1 and 2 of DS1 on the outdoor unit control board. In case the indoor unit control board has DS7, refer to the following table. Try the combinations of dip switches for DS1 and DS7 on the outdoor and indoor unit control board, respectively, one by one. Check that any combinations clear the communication error. If the correct combinations are selected, the communication error is cleared immediately. Power reset is not necessary. These dip switches change the termination resistance value of the communication circuit.

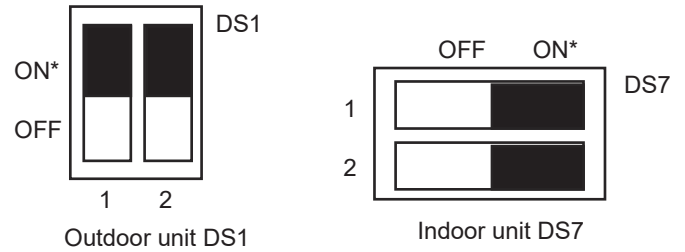

(\*) Default factory setting

Dip Switch Setting Combinations

Setting Combinations	DS1 on the outdoor unit control board	DS7 on the indoor unit control board
1*	(both) ON	(both) ON
2	(both) OFF	(both) ON
3	(both) ON	(both) OFF
4	(both) OFF	(both) OFF

(\*) Default factory setting

The integrated control module has some onboard tools that can be used to troubleshoot the network. These tools are: red communications LED, green receive (Rx) LED, and the learn button.

- Red communications LED – Indicates the status of the network. The table below indicates the LED status and the corresponding potential problem.
- Green receive LED – Indicates network traffic. The table below indicates the LED status and the corresponding potential problem.
- LEARN button – Used to reset the network. Press the button for approximately 5 seconds to reset the network.

LED COLOR	LED Status	Indication	Probable Causes	Corrective Actions
Red Communications LED Outdoor unit control board: (H1P) Indoor unit control board: (H2P)	Off	Normal condition	• None	• None
	1 Flash	Communications failure	• Unknown packet is received • Communications failure	• Depress learn button • Verify wiring connection
	2 Flash	Out-of-box reset	• Control power up • Learn button depressed	• None
Green Receive LED Outdoor unit control board: (H2P) Indoor unit control board: (H3P)	Off	No power Communications error	• No power to unit • Open fuse • Communication error	• Check circuit breakers and fuses; Reset/Replace if needed • Reset network by depressing learn button • Check communication wires (terminal 1/terminal 2 wires); Replace if needed • Check for shorts in low voltage wiring.
	1 Steady Flash	No network found	• Broken/disconnected communication wire(s) • Unit is installed as a legacy/traditional system	• Check communication wires (terminal 1/terminal 2 wires); Replace if needed • Check installation type (legacy/traditional or communicating)
	Rapid Flashing	Normal network traffic	• Control is "talking" on network as expected	• None
	On Solid	Terminal 1/Terminal 2 miss-wire	• Terminal 1 and Terminal 2 wires reversed at indoor unit, thermostat, or outdoor unit • Short between terminal 1 and terminal 2 wires • Short between terminal 1 or terminal 2 two wires and terminal C (24VAC) or terminal R (24VAC, COM)	• Check communication wires (terminal 1/terminal 2 wires); Replace if needed

# TROUBLESHOOTING

## CHARGE VERIFICATION TEST TROUBLESHOOTING

Charge Verification Test runs the unit at approximately 50% capacity for a duration of 2 hours (unless stopped earlier). This test is meant to help accurately adjust the amount of refrigerant charge for optimum performance. Once the test is started, it is expected to take about 20-25 mins for the unit to get stable and start displaying the Subcooling at liquid service valve (in Fahrenheit) on the thermostat AND on the outdoor unit PCB. Should it fail to do so, one or more of the below messages shall be displayed on the thermostat screen (along with blinking “cha” on the outdoor unit PCB). Please refer to the below mentioned probable causes and corrective actions corresponding to the message being displayed.

Items below are messages only displayed on the thermostat screen DURING CHARGE VERIFICATION TEST			
Thermostat Display	Description	Probable causes	Corrective actions
Compressor speed out of range	Compressor is running at a lower/higher frequency than the specified charge verification frequency	<ul style="list-style-type: none"> <li>Air re-circulation on Outdoor Unit</li> <li>Severe refrigerant overcharge/undercharge</li> <li>Ambient air thermistor improperly installed</li> <li>Discharge thermistor improperly installed</li> <li>Suction thermistor improperly installed</li> <li>Heat exchanger thermistor improperly installed</li> </ul>	<ul style="list-style-type: none"> <li>Confirm all required installation clearances for the outdoor unit are maintained (refer to installation manual). If not, increase clearances accordingly.</li> <li>Re-confirm the refrigerant addition/removal amount calculation using installation manual and ensure correct charge amount is weighed in as per lineset length. Fix any leaks in the system.</li> <li>Check the subcooling at liquid service valve by using manifold gauge.</li> <li>Ensure the ambient air thermistor is not touching heat exchanger coil</li> <li>Ensure discharge thermistor is secured in housing and there is nothing trapping heat around it.</li> <li>Ensure suction thermistor is properly installed and well insulated.</li> <li>Ensure heat exchanger thermistor is secured in housing and there is nothing trapping heat around it.</li> </ul>
ID SH out of range	Superheat obtained at the Indoor coil outlet is outside the specified range for charge verification	<ul style="list-style-type: none"> <li>Severe refrigerant undercharge</li> <li>Indoor Gas thermistor improperly installed</li> <li>Discharge thermistor improperly installed</li> <li>Indoor EEV improperly installed to EEV body</li> <li>Indoor airflow unstable</li> <li>Dip switch for Indoor EEV (located on Indoor unit PCB) set incorrectly</li> </ul>	<ul style="list-style-type: none"> <li>Re-confirm the refrigerant addition/removal amount calculation using installation manual and ensure correct charge amount is weighed in as per lineset length. Fix any leaks in the system.</li> <li>Check the subcooling at liquid service valve by using manifold gauge.</li> <li>Ensure Indoor gas thermistor is secured in housing and well insulated.</li> <li>Ensure discharge thermistor is secured in housing and there is nothing trapping heat around it.</li> <li>Check if EEV coil is correctly secured to EEV body. Protrusion on EEV coil should be clicked into place on dimple of EEV body.</li> <li>Check for any obstructions/leaks in the ducting</li> <li>Check if the dipswitches are set correctly on the Indoor unit PCB with the help of the following section in this manual : Servicing - Emergency Mode for EEV applicable Indoor unit</li> </ul>
Outdoor temp out of range - Please weigh in charge	Outdoor temperature is currently not within 65°F to 105°F, and thus refrigerant should be weighed in instead of using Subcool adjustment	<p>[ONLY IF COMES UP FALSELY]</p> <ul style="list-style-type: none"> <li>Air re-circulation on Outdoor Unit</li> <li>Ambient air thermistor improperly installed</li> </ul>	<ul style="list-style-type: none"> <li>Confirm all required installation clearances for the outdoor unit are maintained (refer to installation manual). If not, increase clearances accordingly.</li> <li>Ensure the ambient air thermistor is not touching heat exchanger coil</li> </ul>

# THERMISTOR RESISTANCE & TEMPERATURE CHARACTERISTICS

		<b>Tm : Coil</b> <b>Tl : Liquid</b> <b>Ts : Suction</b> <b>Tb : Defrost (*)</b> <b>Tgi: Indoor Gas</b> <b>Tli: Indoor Liquid</b>		<b>Td : Discharge</b>		<b>Ta : Outdoor air</b>	
TEMP	TEMP	Thermistor Resistance	Volts	Thermistor Resistance	Volts	Thermistor Resistance	Volts
(°C)	(°F)	R (kΩ)	DC (V)	R (kΩ)	DC (V)	R (kΩ)	DC (V)
-30	-22	364.43	4.58	4759.15	4.96	362.48	4.58
-25	-13	267.00	4.45	3454.24	4.94	265.99	4.45
-20	-4	197.81	4.29	2533.62	4.92	197.31	4.28
-15	5	148.10	4.09	1877.01	4.90	147.86	4.09
-10	14	111.99	3.86	1403.82	4.86	111.88	3.86
-5	23	85.49	3.61	1059.45	4.82	85.43	3.61
0	32	65.84	3.33	806.47	4.77	65.80	3.33
5	41	51.09	3.04	618.95	4.70	51.10	3.04
10	50	39.96	2.74	478.76	4.62	39.99	2.74
15	59	31.50	2.44	373.11	4.53	31.54	2.44
20	68	25.01	2.16	292.86	4.41	25.06	2.16
25	77	20.00	1.89	231.44	4.28	20.04	1.89
30	86	16.10	1.64	184.11	4.13	16.13	1.64
35	95	13.04	1.42	147.37	3.95	13.07	1.42
40	104	10.63	1.22	118.68	3.76	10.65	1.22
45	113	8.71	1.04	96.13	3.56	8.73	1.05
50	122	7.18	0.89	78.29	3.34	7.18	0.89
55	131	5.95	0.76	64.10	3.11	-	-
60	140	4.96	0.65	52.76	2.87	-	-
65	149	4.16	0.56	43.63	2.64	-	-
70	158	3.50	0.48	36.26	2.41	-	-
75	167	2.96	0.41	30.27	2.18	-	-
80	176	2.51	0.35	25.38	1.97	-	-
85	185	2.14	0.30	21.37	1.77	-	-
90	194	1.83	0.26	18.06	1.58	-	-
95	203	1.58	0.23	15.33	1.41	-	-
100	212	1.36	0.20	13.06	1.25	-	-
105	221	1.18	0.17	11.17	1.11	-	-
110	230	1.02	0.15	9.59	0.99	-	-
115	239	0.89	0.13	8.25	0.87	-	-
120	248	0.78	0.12	7.13	0.77	-	-
125	257	0.68	0.10	6.18	0.68	-	-
130	266	0.60	0.09	5.37	0.61	-	-
135	275	0.53	0.08	4.69	0.54	-	-
140	284	0.47	0.07	4.10	0.48	-	-
145	293	0.42	0.06	3.59	0.42	-	-
150	302	0.37	0.06	3.16	0.37	-	-

(\*) HP only.

# PRESSURE VS TEMPERATURE CHART

## R32 Pressure vs. Temperature Chart

PSIG	°F	PSIG	°F	PSIG	°F	PSIG	°F	PSIG	°F	PSIG	°F
2.0	-119.58	102.0	23.99	202.0	64.31	302.0	91.41	402.0	112.37	502.0	129.66
4.0	-101.58	104.0	25.04	204.0	64.95	304.0	91.88	404.0	112.75	504.0	129.97
6.0	-89.98	106.0	26.08	206.0	65.57	306.0	92.34	406.0	113.12	506.0	130.29
8.0	-81.20	108.0	27.11	208.0	66.20	308.0	92.81	408.0	113.50	508.0	130.60
10.0	-74.06	110.0	28.12	210.0	66.82	310.0	93.27	410.0	113.87	510.0	130.92
12.0	-67.99	112.0	29.12	212.0	67.43	312.0	93.73	412.0	114.24	512.0	131.23
14.0	-62.68	114.0	30.10	214.0	68.04	314.0	94.18	414.0	114.61	514.0	131.55
16.0	-57.94	116.0	31.07	216.0	68.65	316.0	94.64	416.0	114.98	516.0	131.86
18.0	-53.66	118.0	32.03	218.0	69.25	318.0	95.09	418.0	115.34	518.0	132.17
20.0	-49.74	120.0	32.98	220.0	69.84	320.0	95.54	420.0	115.71	520.0	132.48
22.0	-46.12	122.0	33.91	222.0	70.44	322.0	95.99	422.0	116.07	522.0	132.79
24.0	-42.74	124.0	34.84	224.0	71.03	324.0	96.43	424.0	116.44	524.0	133.09
26.0	-39.59	126.0	35.75	226.0	71.61	326.0	96.87	426.0	116.80	526.0	133.40
28.0	-36.62	128.0	36.65	228.0	72.19	328.0	97.32	428.0	117.16	528.0	133.71
30.0	-33.81	130.0	37.54	230.0	72.77	330.0	97.75	430.0	117.52	530.0	134.01
32.0	-31.14	132.0	38.42	232.0	73.34	332.0	98.19	432.0	117.87	532.0	134.32
34.0	-28.60	134.0	39.29	234.0	73.91	334.0	98.63	434.0	118.23	534.0	134.62
36.0	-26.18	136.0	40.15	236.0	74.48	336.0	99.06	436.0	118.59	536.0	134.92
38.0	-23.86	138.0	41.00	238.0	75.04	338.0	99.49	438.0	118.94	538.0	135.22
40.0	-21.63	140.0	41.84	240.0	75.60	340.0	99.92	440.0	119.29	540.0	135.52
42.0	-19.48	142.0	42.68	242.0	76.16	342.0	100.35	442.0	119.64	542.0	135.82
44.0	-17.42	144.0	43.50	244.0	76.71	344.0	100.77	444.0	119.99	544.0	136.12
46.0	-15.42	146.0	44.31	246.0	77.26	346.0	101.20	446.0	120.34	546.0	136.42
48.0	-13.49	148.0	45.12	248.0	77.80	348.0	101.62	448.0	120.69	548.0	136.72
50.0	-11.63	150.0	45.92	250.0	78.35	350.0	102.04	450.0	121.04	550.0	137.02
52.0	-9.82	152.0	46.71	252.0	78.88	352.0	102.46	452.0	121.38	552.0	137.31
54.0	-8.06	154.0	47.49	254.0	79.42	354.0	102.87	454.0	121.73	554.0	137.61
56.0	-6.35	156.0	48.27	256.0	79.95	356.0	103.29	456.0	122.07	556.0	137.90
58.0	-4.69	158.0	49.03	258.0	80.48	358.0	103.70	458.0	122.41	558.0	138.19
60.0	-3.07	160.0	49.79	260.0	81.01	360.0	104.11	460.0	122.75	560.0	138.48
62.0	-1.50	162.0	50.55	262.0	81.53	362.0	104.52	462.0	123.09	562.0	138.78
64.0	0.04	164.0	51.29	264.0	82.05	364.0	104.93	464.0	123.43	564.0	139.07
66.0	1.54	166.0	52.03	266.0	82.57	366.0	105.34	466.0	123.77	566.0	139.36
68.0	3.01	168.0	52.77	268.0	83.08	368.0	105.74	468.0	124.10	568.0	139.64
70.0	4.44	170.0	53.49	270.0	83.59	370.0	106.14	470.0	124.44	570.0	139.93
72.0	5.85	172.0	54.21	272.0	84.10	372.0	106.54	472.0	124.77	572.0	140.22
74.0	7.22	174.0	54.92	274.0	84.61	374.0	106.94	474.0	125.11	574.0	140.51
76.0	8.56	176.0	55.63	276.0	85.11	376.0	107.34	476.0	125.44	576.0	140.79
78.0	9.88	178.0	56.33	278.0	85.61	378.0	107.74	478.0	125.77	578.0	141.08
80.0	11.18	180.0	57.03	280.0	86.11	380.0	108.13	480.0	126.10	580.0	141.36
82.0	12.44	182.0	57.72	282.0	86.60	382.0	108.52	482.0	126.43	582.0	141.64
84.0	13.69	184.0	58.40	284.0	87.10	384.0	108.92	484.0	126.75	584.0	141.93
86.0	14.91	186.0	59.08	286.0	87.59	386.0	109.31	486.0	127.08	586.0	142.21
88.0	16.11	188.0	59.75	288.0	88.07	388.0	109.69	488.0	127.41	588.0	142.49
90.0	17.29	190.0	60.42	290.0	88.56	390.0	110.08	490.0	127.73	590.0	142.77
92.0	18.46	192.0	61.08	292.0	89.04	392.0	110.47	492.0	128.05	592.0	143.05
94.0	19.60	194.0	61.74	294.0	89.52	394.0	110.85	494.0	128.38	594.0	143.33
96.0	20.72	196.0	62.39	296.0	90.00	396.0	111.23	496.0	128.70	596.0	143.61
98.0	21.83	198.0	63.04	298.0	90.47	398.0	111.61	498.0	129.02	598.0	143.88
100.0	22.91	200.0	63.68	300.0	90.94	400.0	111.99	500.0	129.34	600.0	144.16

# LIQUID LINE TEMPERATURE CHART

Required Liquid Line Temperature						
LIQUID PRESSURE AT STOP VALVE (PSIG)	REQUIRED SUBCOOLING TEMPERATURE (°F)					
	6	8	10	12	14	16
189	59	57	55	53	51	49
195	61	59	57	55	53	51
202	63	61	59	57	55	53
208	65	63	61	59	57	55
215	67	65	63	61	59	57
222	69	67	65	63	61	59
229	71	69	67	65	63	61
236	73	71	69	67	65	63
243	74	72	70	68	66	64
251	76	74	72	70	68	66
259	79	77	75	73	71	69
266	80	78	76	74	72	70
274	82	80	78	76	74	72
283	84	82	80	78	76	74
291	86	84	82	80	78	76
299	88	86	84	82	80	78
308	90	88	86	84	82	80
317	92	90	88	86	84	82
326	94	92	90	88	86	84
335	96	94	92	90	88	86
345	98	96	94	92	90	88
354	100	98	96	94	92	90
364	102	100	98	96	94	92
374	104	102	100	98	96	94
384	106	104	102	100	98	96
395	108	106	104	102	100	98
406	110	108	106	104	102	100
416	112	110	108	106	104	102
427	114	112	110	108	106	104
439	116	114	112	110	108	106
450	118	116	114	112	110	108
462	120	118	116	114	112	110
474	122	120	118	116	114	112
486	123	121	119	117	115	113
499	123	121	119	117	115	113
511	123	121	119	117	115	113

# WIRING DIAGRAMS

## Outdoor AC 1.5 - 3.0 ton



**WARNING**

HIGH VOLTAGE!  
DISCONNECT ALL POWER BEFORE SERVICING OR INSTALLING THIS UNIT. MULTIPLE POWER SOURCES MAY BE PRESENT. FAILURE TO DO SO MAY CAUSE PROPERTY DAMAGE, PERSONAL INJURY OR DEATH.

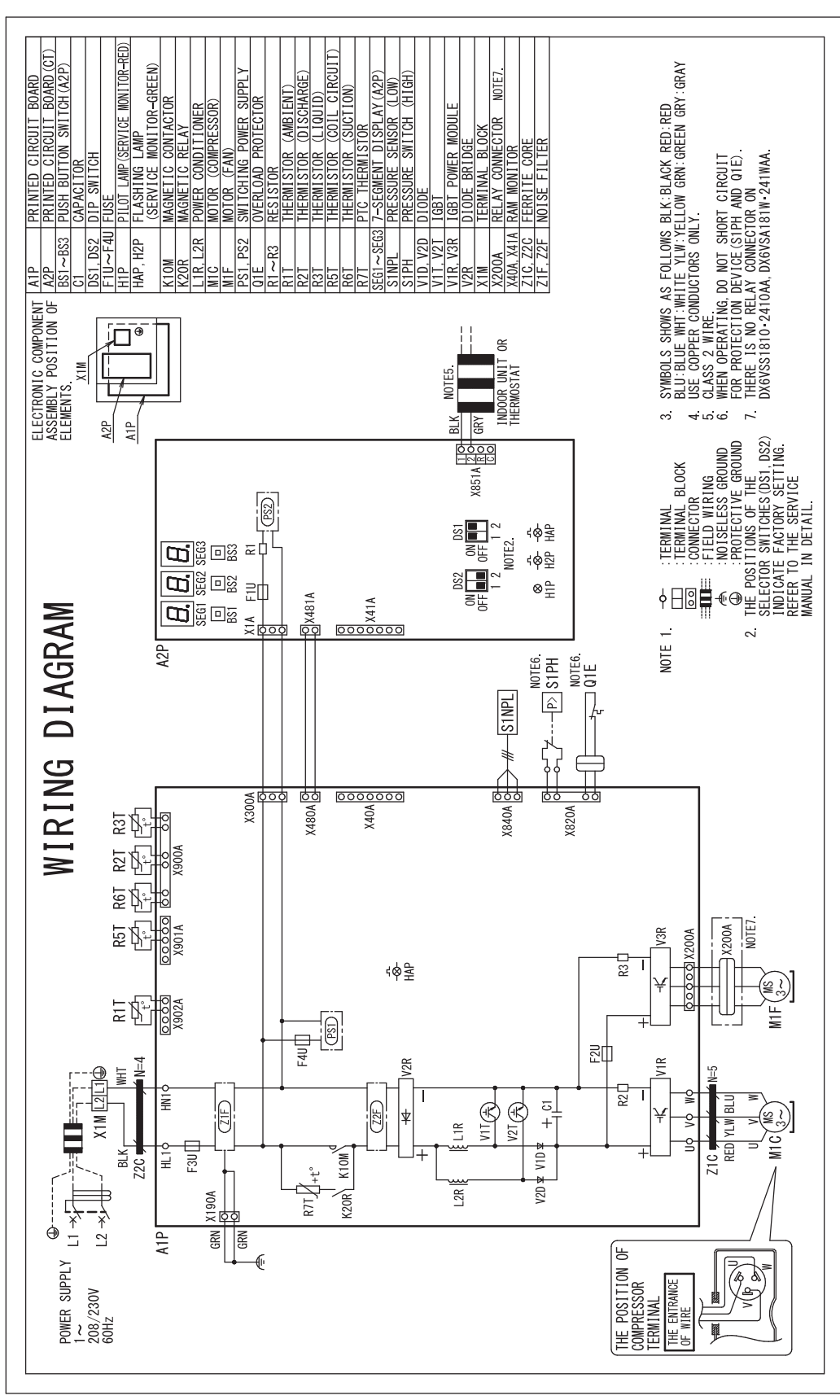

Wiring is subject to change. Always refer to the wiring diagram on the unit for the most up-to-date wiring.



# WIRING DIAGRAMS

## Outdoor HP 1.5 - 3.0 ton

**WARNING**

HIGH VOLTAGE!  
DISCONNECT ALL POWER BEFORE SERVICING OR INSTALLING THIS UNIT. MULTIPLE POWER SOURCES MAY BE PRESENT. FAILURE TO DO SO MAY CAUSE PROPERTY DAMAGE, PERSONAL INJURY OR DEATH.

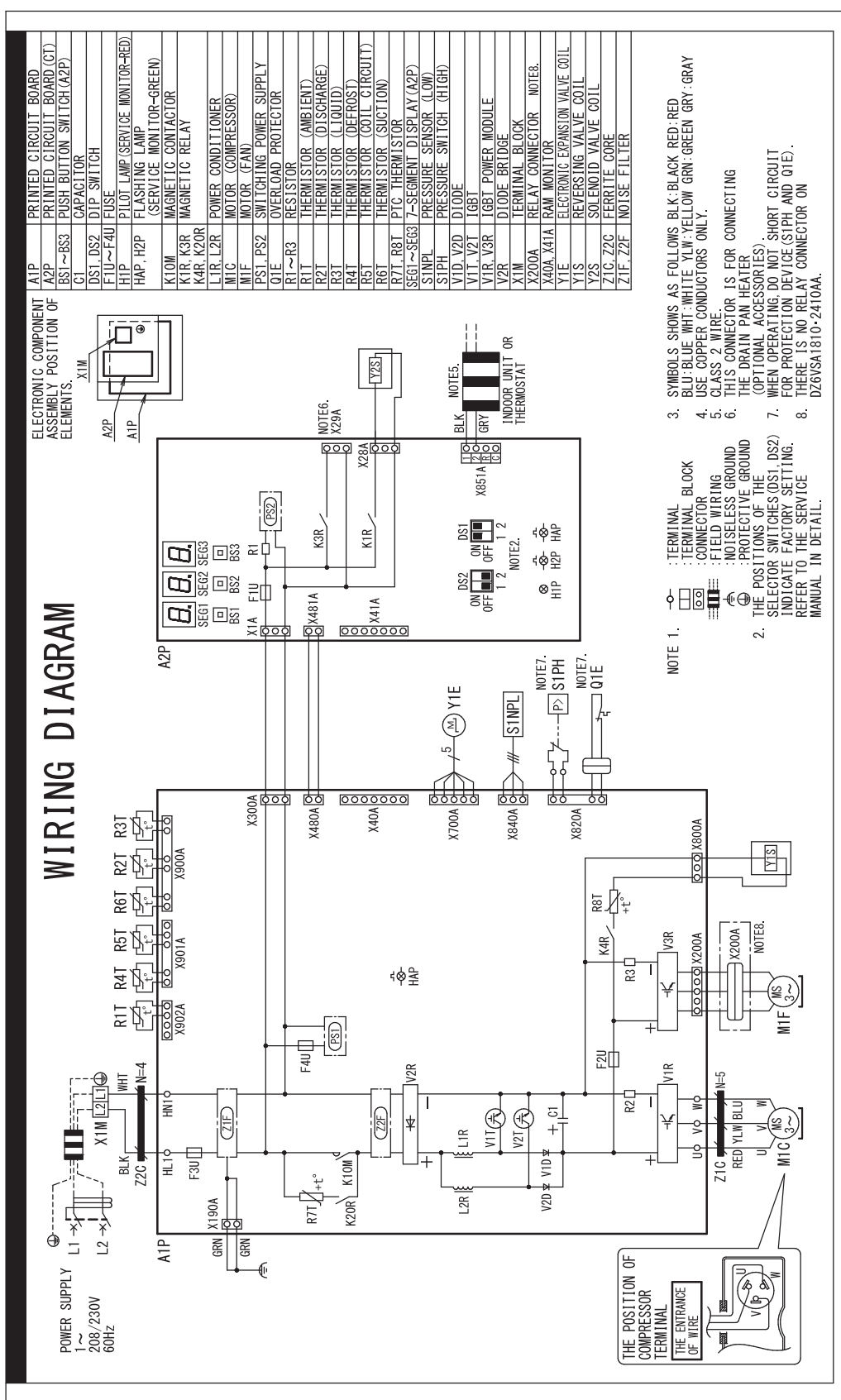

Wiring is subject to change. Always refer to the wiring diagram on the unit for the most up-to-date wiring.

# WIRING DIAGRAMS

## Outdoor HP 3.5 - 5.0 ton

**WARNING**

HIGH VOLTAGE!  
DISCONNECT ALL POWER BEFORE SERVICING OR INSTALLING THIS UNIT. MULTIPLE POWER SOURCES MAY BE PRESENT. FAILURE TO DO SO MAY CAUSE PROPERTY DAMAGE, PERSONAL INJURY OR DEATH.

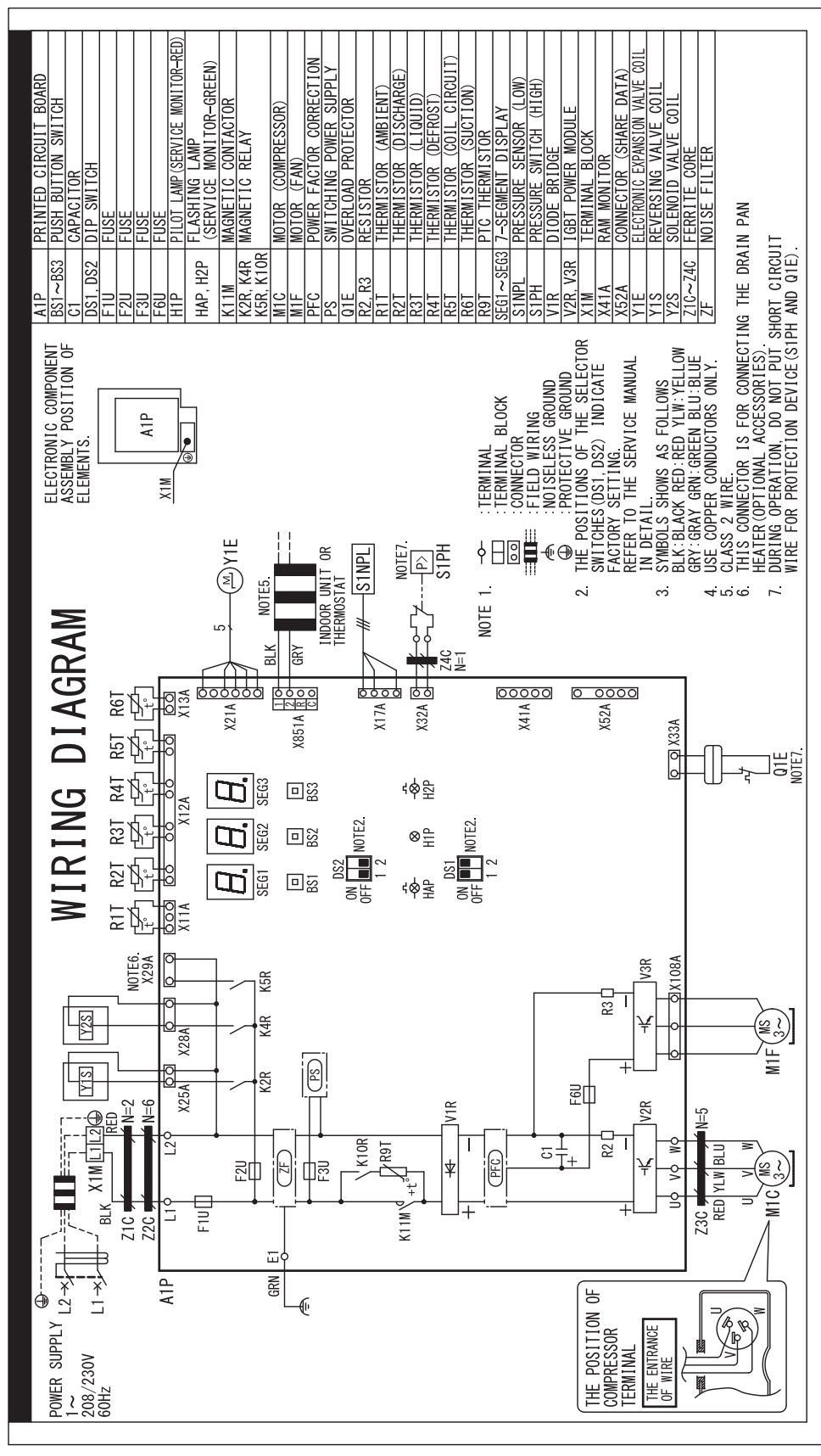

Wiring is subject to change. Always refer to the wiring diagram on the unit for the most up-to-date wiring.

# WIRING DIAGRAMS

## Outdoor Enhanced Capacity HP 2.0 ton & High Efficiency AC 2.0 ton

**WARNING**

HIGH VOLTAGE!  
DISCONNECT ALL POWER BEFORE SERVICING OR INSTALLING THIS UNIT. MULTIPLE POWER SOURCES MAY BE PRESENT. FAILURE TO DO SO MAY CAUSE PROPERTY DAMAGE, PERSONAL INJURY OR DEATH.

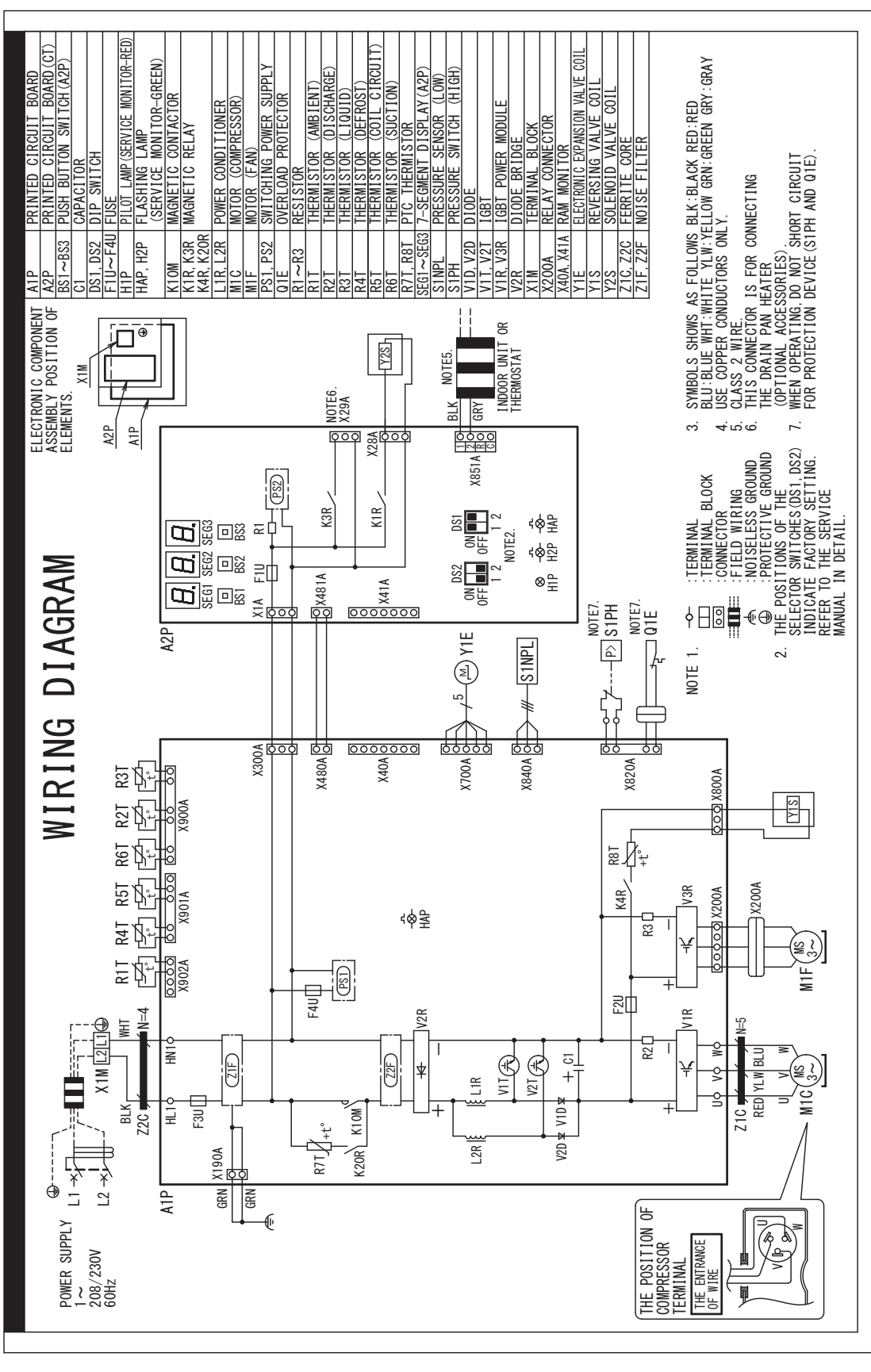

Wiring is subject to change. Always refer to the wiring diagram on the unit for the most up-to-date wiring.

# WIRING DIAGRAMS

## Outdoor Enhanced Capacity HP 3.0 - 4.0 ton & High Efficiency AC 3.0 - 4.0 ton

**WARNING**

HIGH VOLTAGE!  
DISCONNECT ALL POWER BEFORE SERVICING OR INSTALLING THIS UNIT. MULTIPLE POWER SOURCES MAY BE PRESENT. FAILURE TO DO SO MAY CAUSE PROPERTY DAMAGE, PERSONAL INJURY OR DEATH.

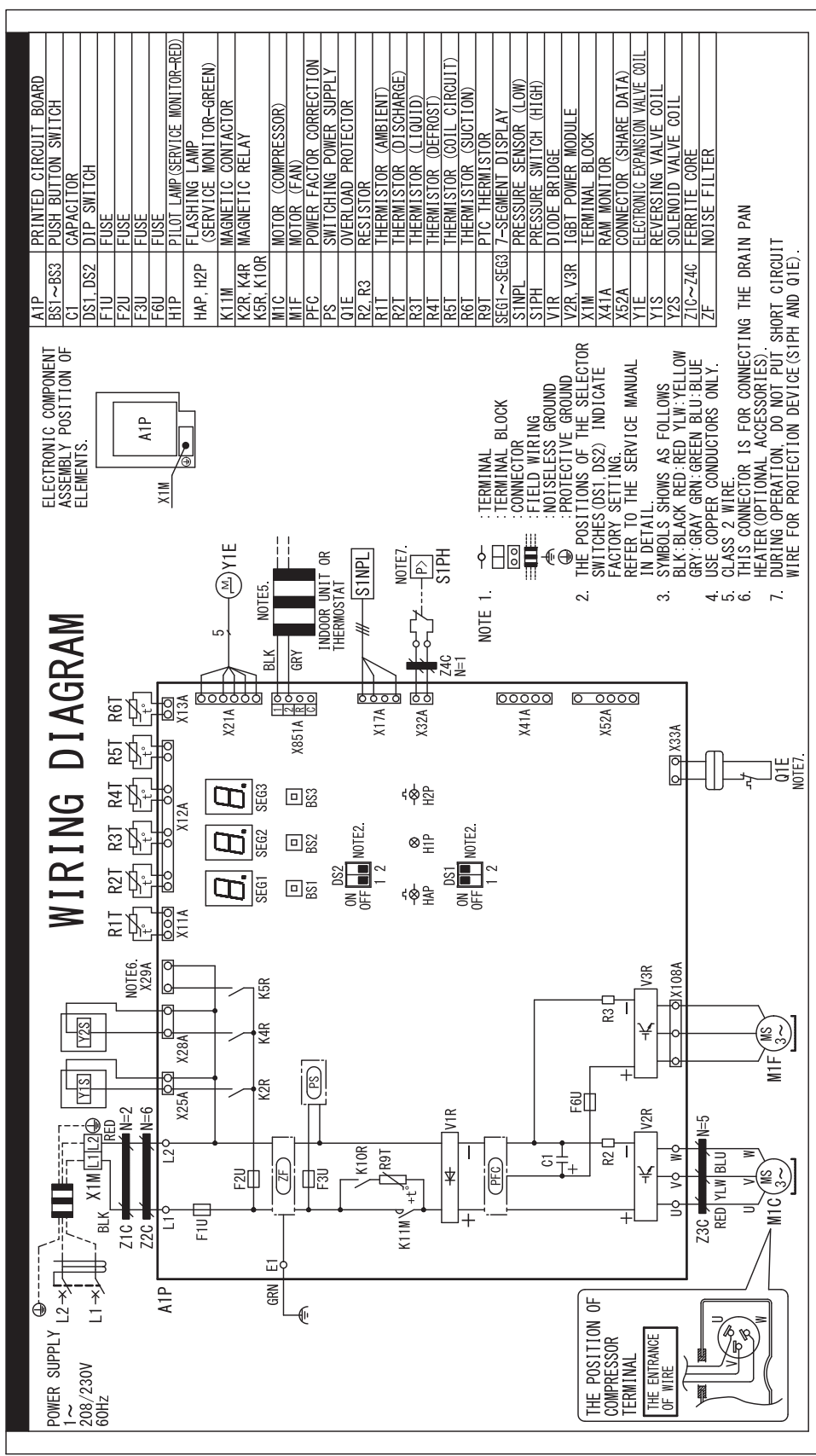

Wiring is subject to change. Always refer to the wiring diagram on the unit for the most up-to-date wiring.

# WIRING DIAGRAMS

## 208/230 V EEV Air Handler



### WARNING

HIGH VOLTAGE! DISCONNECT ALL POWER BEFORE SERVICING. MULTIPLE POWER SOURCES MAY BE PRESENT. FAILURE TO DO SO MAY CAUSE PROPERTY DAMAGE, PERSONAL INJURY OR DEATH.



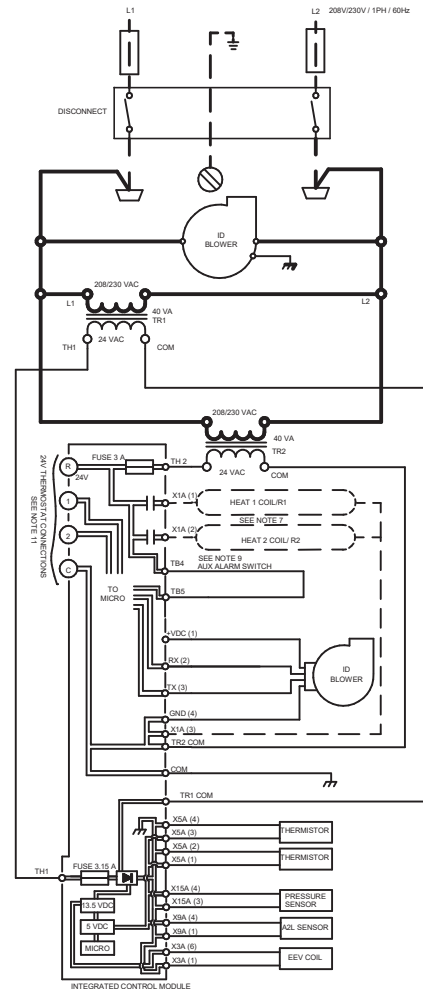
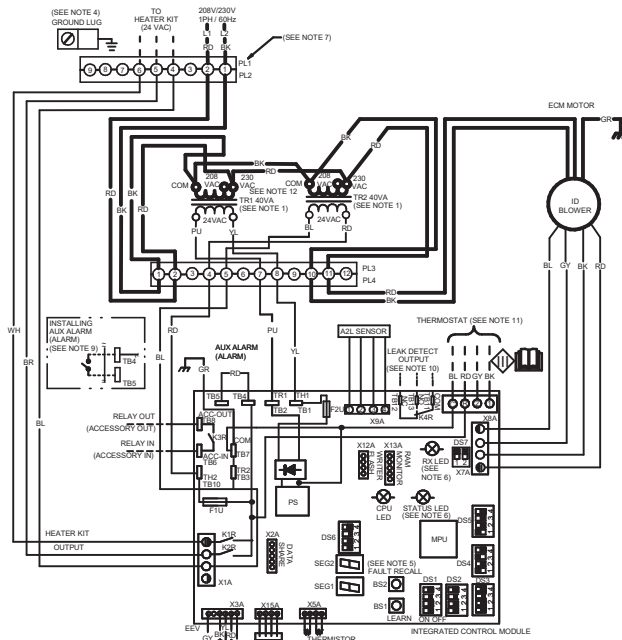

- NOTES:**
1. PLACE RED WIRES ON 208 V TERMINAL OF 2-TRANSFORMER (TR1/TR2) FOR 208 VAC OPERATION.
  2. MANUFACTURER'S SPECIFIED REPLACEMENT PARTS MUST BE USED WHEN SERVICING.
  3. IF ANY OF THE ORIGINAL WIRES AS SUPPLIED WITH THIS UNIT MUST BE REPLACED, IT MUST BE REPLACED WITH WIRING MATERIAL HAVING A TEMPERATURE RATING OF AT LEAST 105°C. USE COPPER CONDUCTORS ONLY.
  4. UNIT MUST BE PERMANENTLY GROUNDED AND CONFORM TO N.E.C AND LOCAL CODES.
  5. TO RECALL THE LAST 6 FAULTS, MOST RECENT TO LEAST RECENT, DEPRESS FAULT RECALL BUTTON FOR MORE THAN 2 SECONDS WHILE IN STANDBY (NO THERMOSTAT INPUTS)
  6. RED STATUS LED PROVIDES NETWORK STATUS. GREEN RX LED INDICATES NETWORK TRAFFIC. USE LEARN BUTTON TO RESET NETWORK.
  7. DISCARD CONNECTOR PL1 WHEN INSTALLING OPTIONAL HEAT KIT.
  8. THE POSITION OF SELECTOR SWITCHES (DS1 - DS7) INDICATE FACTORY SETTING.
  9. REMOVE SHORT RED CIRCUITING WIRE AND PUT AUX ALARM SWITCH WHEN INSTALLING AUX ALARM SWITCH, CONDENSATE SWITCH, ETC.
  10. THIS OUTPUT OPERATES WHEN A REFRIGERANT LEAK IS DETECTED. (DRY CONTACT) USE THIS CONTACT WHEN INTERLOCKING UV LIGHT, DAMPER, ETC.
  11. USE N.E.C CLASS 2 WIRE.
  12. LOW VOLTAGE TRANSFORMER RATED 24VAC OUTPUT 40VA @1.667 AMP.

COMPONENT LEGEND:		COMPONENT CODES:	
LOW VOLTAGE	—	PL1, PL2	POWER/HEATER CONNECTOR
LOW VOLTAGE FIELD	—	DS1 - DS7	SELECTOR SWITCH
HIGH VOLTAGE	—	TR	TRANSFORMER
HIGH VOLTAGE FIELD	—	PL3, PL4	TRANSFORMER CONNECTOR
JUNCTION	⊕	ID	INDOOR
TERMINAL	○	AUX	AUXILIARY
INTERNAL CONNECTIONS	—	COM	24V COMMON
RESISTOR	⊞	COLOR CODES:	
FUSE (F1U, F2U)	⊞	BL	BLUE
PLUG CONNECTION	⊞	RD	RED
EQUIPMENT GROUND	⊞	YL	YELLOW
FIELD GROUND	⊞	OR	ORANGE
DIP SWITCH(OFF)	⊞	BR	BROWN
ON/OFF	⊞	GR	GREEN
READ THE INSTRUCTIONS	⊞	PU	PURPLE
FIELD SPLICE	⊞	WH	WHITE
CLASS III	⊞		

Wiring is subject to change. Always refer to the wiring diagram on the unit for the most up-to-date wiring.



# WIRING DIAGRAMS

## EEV cased coil



### WARNING

HIGH VOLTAGE! DISCONNECT ALL POWER BEFORE SERVICING. MULTIPLE POWER SOURCES MAY BE PRESENT. FAILURE TO DO SO MAY CAUSE PROPERTY DAMAGE, PERSONAL INJURY OR DEATH.



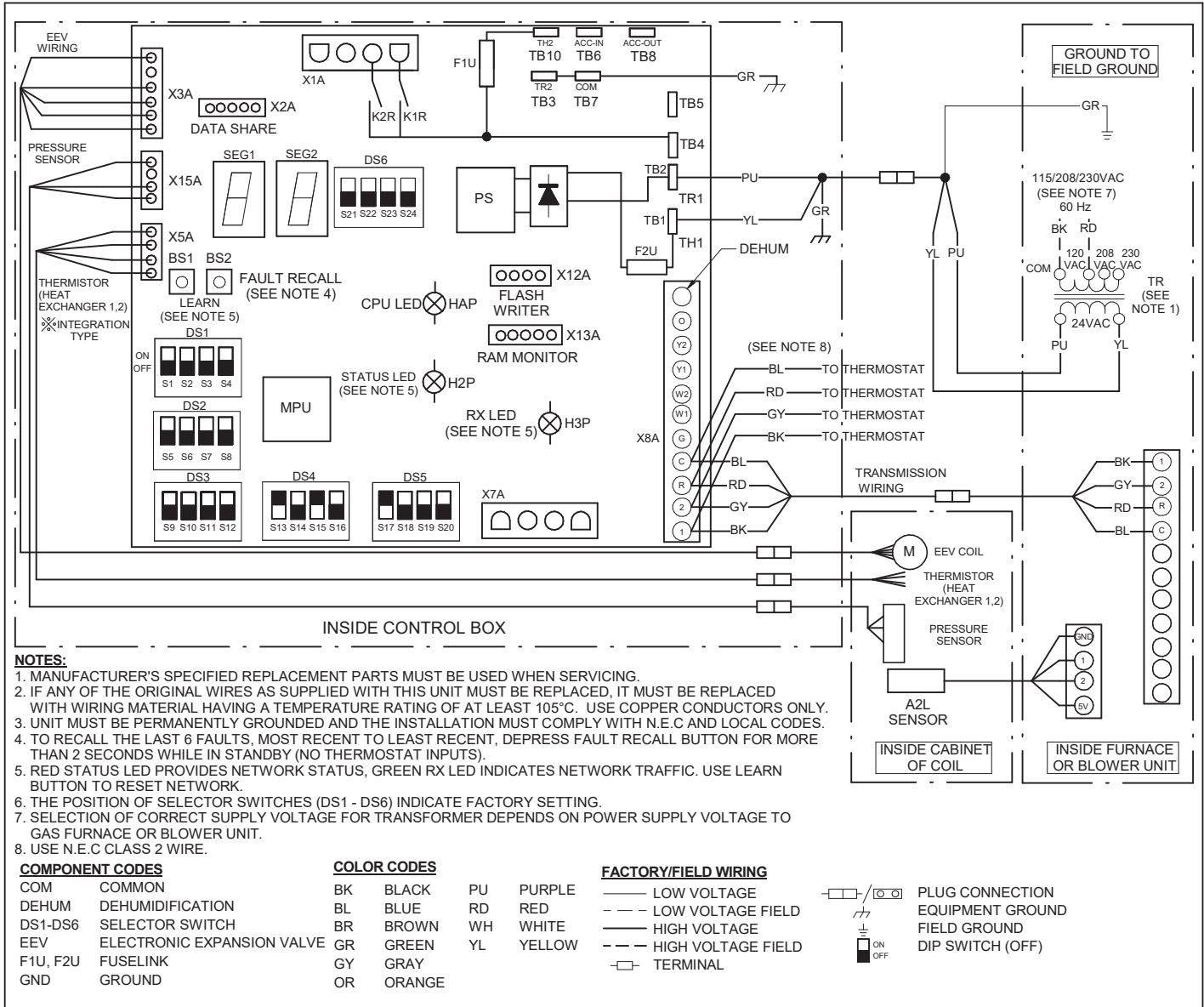

**NOTE:** For systems using the "NON-A2L FURNACE INTEGRATION (DRAGON FLY) KIT", refer to the wiring diagram in the installation manual of this kit.

Wiring is subject to change. Always refer to the wiring diagram on the unit for the most up-to-date wiring.

# REMOVAL & REASSEMBLY PROCEDURE

1.5 - 3.0 ton models HP & AC and 2.0 ton HP Enhanced Capacity and 2.0 ton AC High Efficiency models

## 1.5 - 3.0 ton models and 2.0 ton Enhanced Capacity/High Efficiency models

### 1. Panels

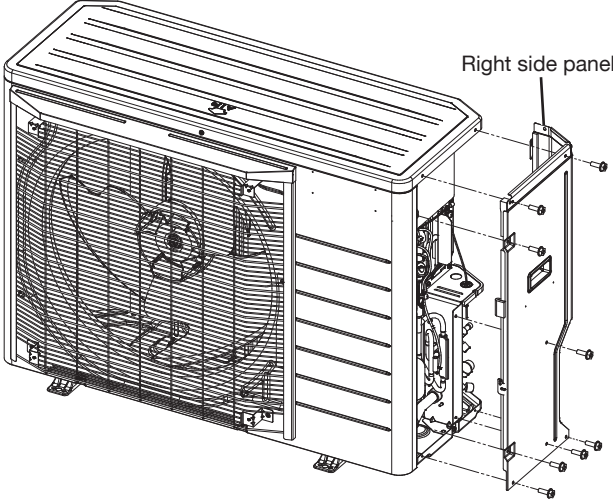
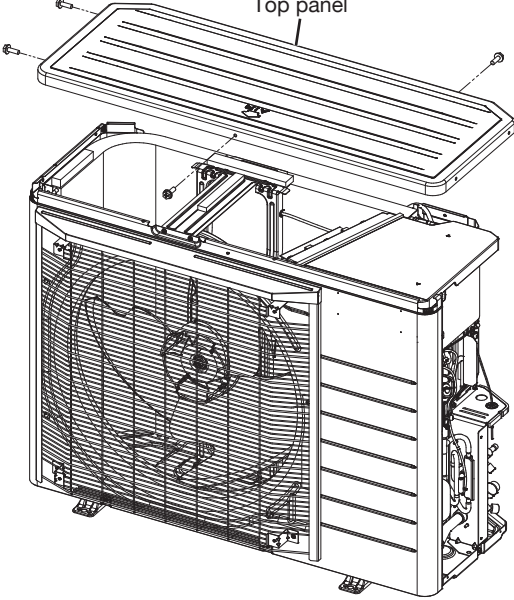
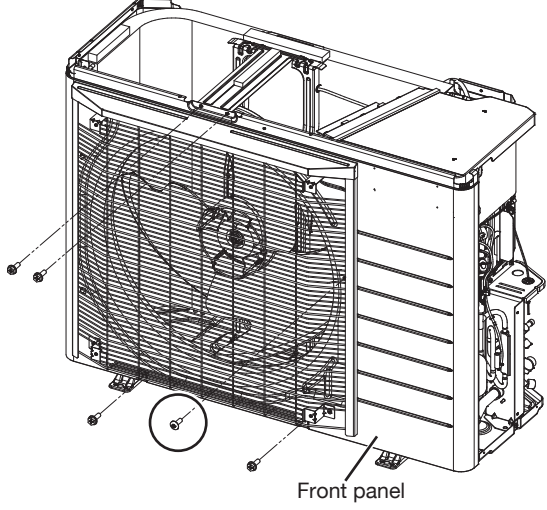
Step	Procedure	Procedure	Points
1	Remove 8 screws and remove the right side panel.		<ul style="list-style-type: none"> <li>■ When reassembling, perform the procedures in inverse order.</li> <li>■ All screws that are not mentioned are hexagon flanged screws (M4 × 12).</li> </ul>
2	Remove 4 screws and remove the top panel.		
3	Remove 5 screws and remove the front panel.		<ul style="list-style-type: none"> <li>■ The screw circled in the illustration is a truss head tapping screw or a hex head screw.</li> </ul>

# REMOVAL & REASSEMBLY PROCEDURE

1.5 - 3.0 ton models HP & AC and 2.0 ton HP Enhanced Capacity and 2.0 ton AC High Efficiency models

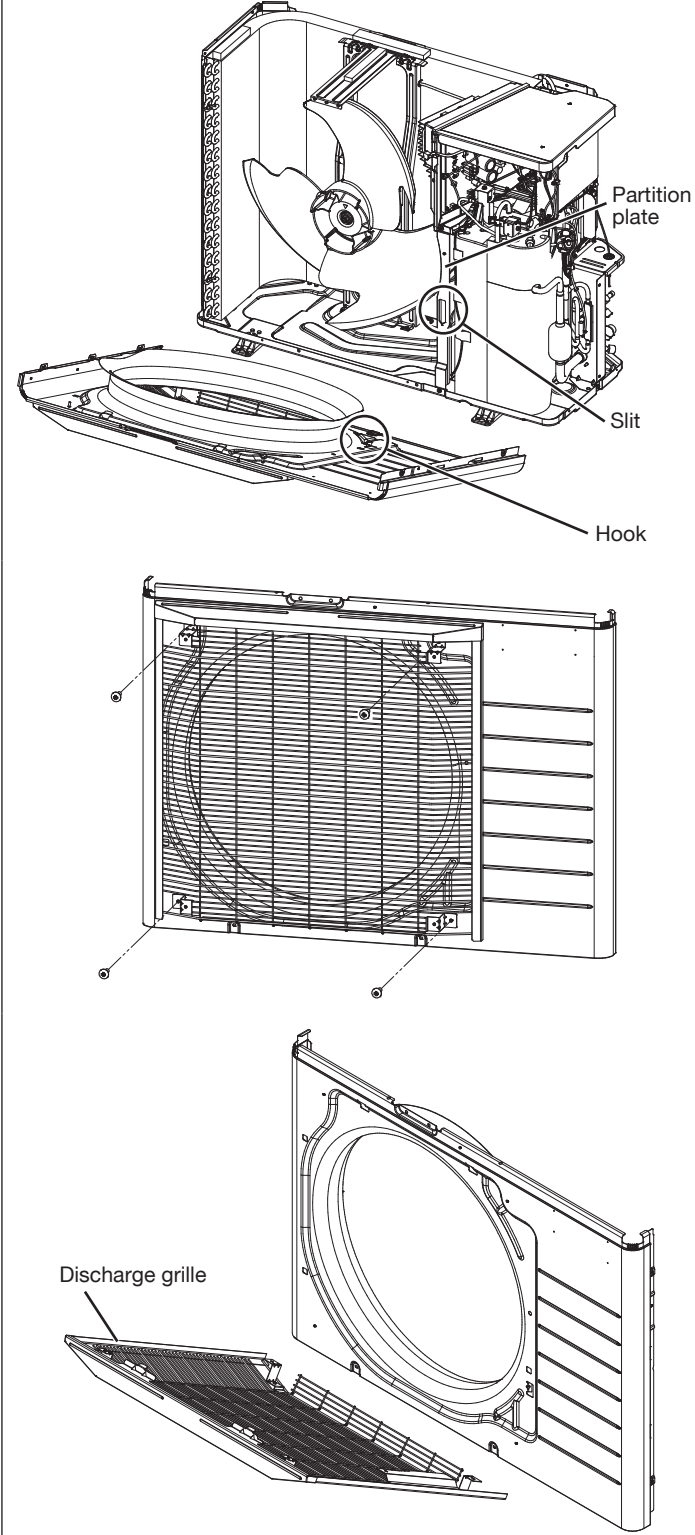
Step	Procedure	Points
4	<p data-bbox="142 746 407 842">Remove 4 screws and remove the discharge grille.</p> 	<ul data-bbox="1141 172 1495 842" style="list-style-type: none"><li>■ When reassembling, insert the hook of the front panel into the slit of the partition plate.</li><li>■ The discharge grille screws are truss head tapping screws or hex head screws.</li></ul>

# REMOVAL & REASSEMBLY PROCEDURE

1.5 - 3.0 ton models HP & AC and 2.0 ton HP Enhanced Capacity and 2.0 ton AC High Efficiency models

Step	Procedure	Points
5	<p>Cut the 2 clamps, remove 3 screws and disconnect the external power supply, ground and communication wires from the terminal block.</p>	<p>■ The 3 screws are pan head tapping screws.                      (a) 1 pc: M5 × 12                      (b) 2 pc: M4 × 10</p>
6	<p>Remove 7 screws and remove the rear plate.</p>	

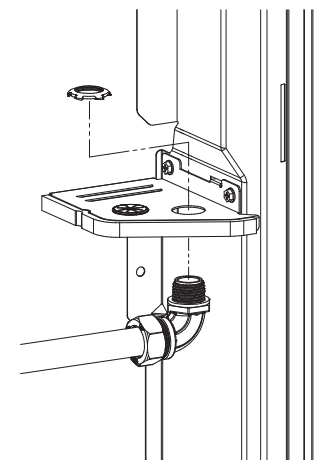
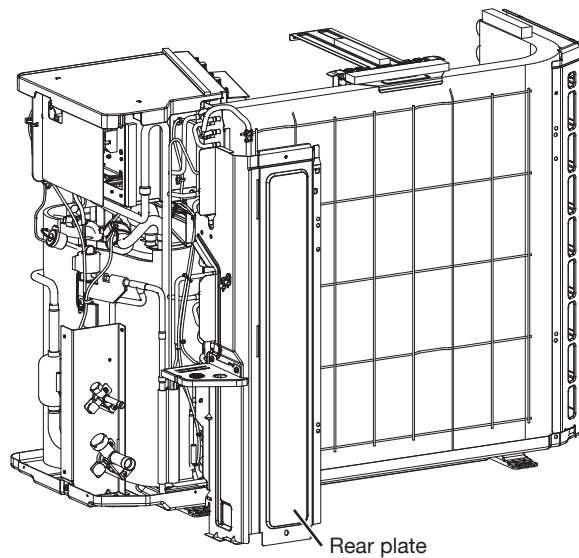
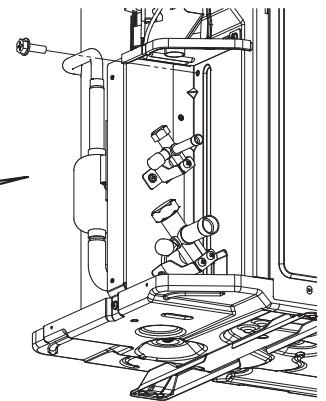
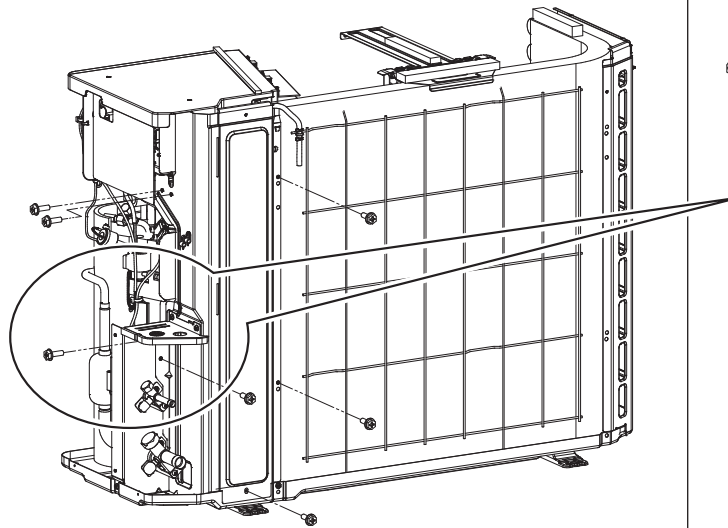
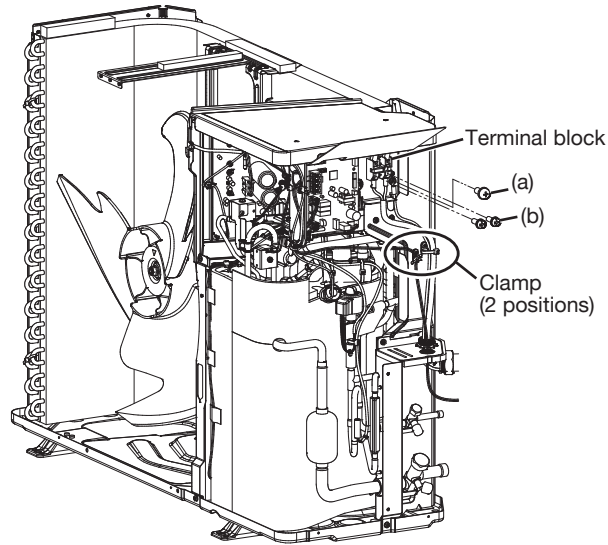

# REMOVAL & REASSEMBLY PROCEDURE

1.5 - 3.0 ton models HP & AC and 2.0 ton HP Enhanced Capacity and 2.0 ton AC High Efficiency models

## 2. Fan and Fan motor

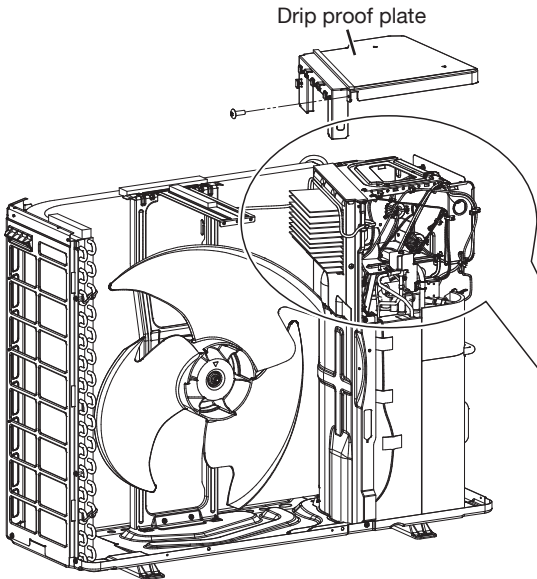
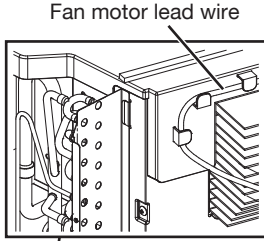
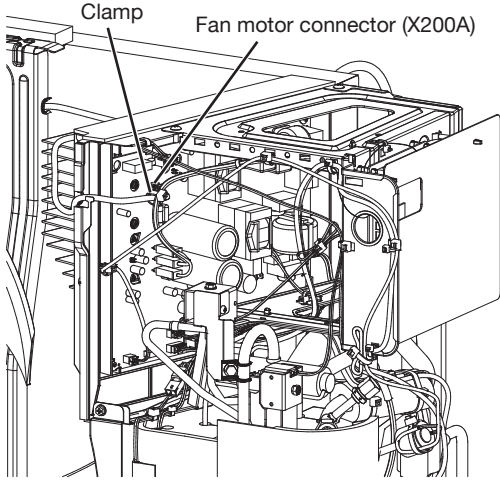
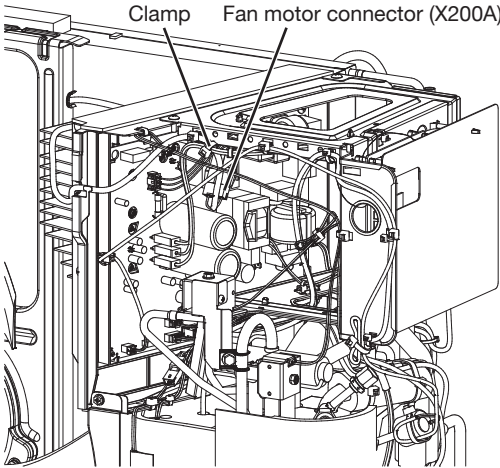
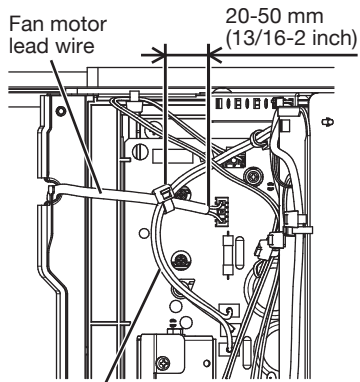
Step		Procedure	Points
1	<p>Remove the 1 screw and remove the drip proof cover.</p> <p>Remove the fan motor lead wire from hook of drip proof cover.</p>	 <p>Drip proof plate</p>	<ul style="list-style-type: none"> <li>■ The screw is a truss head tapping screw.</li> <li>■ When reassembling, fit the fan motor lead wire firmly into the groove of the resin electrical component box.</li> </ul>  <p>Fan motor lead wire</p>
2	<p>Cut the clamp and disconnect the fan motor lead wire.</p>	<p>■ <b>1.5/2.0 ton</b></p>  <p>Clamp Fan motor connector (X200A)</p> <p>■ <b>2.5/3.0 ton and 2.0 ton Enhanced Capacity/High Efficiency models</b></p>  <p>Clamp Fan motor connector (X200A)</p>  <p>Fan motor lead wire 20-50 mm (13/16-2 inch)</p> <p>Compressor lead wire</p>	<p>■ For 1.5/2.0 ton models: When reassembling, clamp the compressor lead wires to position about 20-50 mm (13/16-2 inch) from the end of the protective tube of the fan motor lead wire. Ensure that the compressor lead wires are not under tension.</p>

# REMOVAL & REASSEMBLY PROCEDURE

1.5 - 3.0 ton models HP & AC and 2.0 ton HP Enhanced Capacity and 2.0 ton AC High Efficiency models

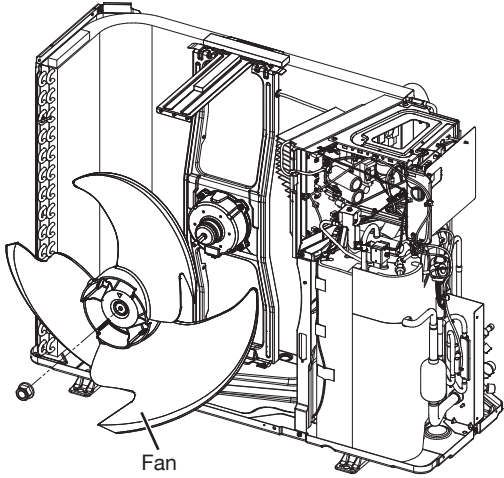
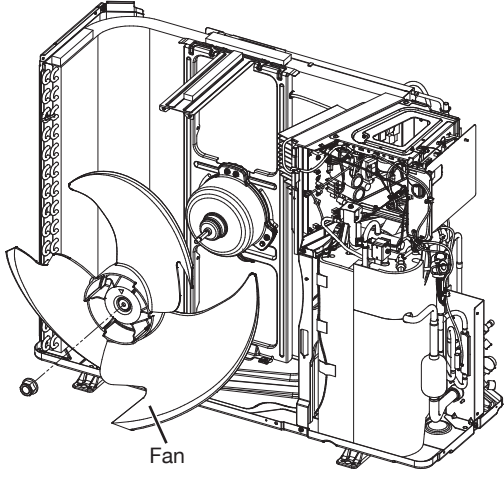
Step	Procedure	Points
3	Remove the nut and remove the fan.	<ul style="list-style-type: none"><li>■ <b>1.5/2.0 ton</b></li></ul>  <p>Fan</p> <ul style="list-style-type: none"><li>■ <b>2.5/3.0 ton and 2.0 ton Enhanced Capacity/High Efficiency models</b></li></ul>  <p>Fan</p>

# REMOVAL & REASSEMBLY PROCEDURE

1.5 - 3.0 ton models HP & AC and 2.0 ton HP Enhanced Capacity and 2.0 ton AC High Efficiency models

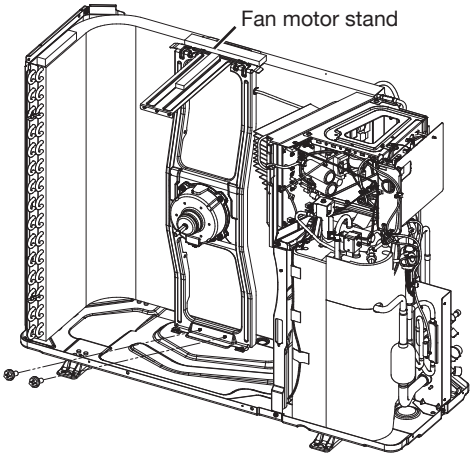
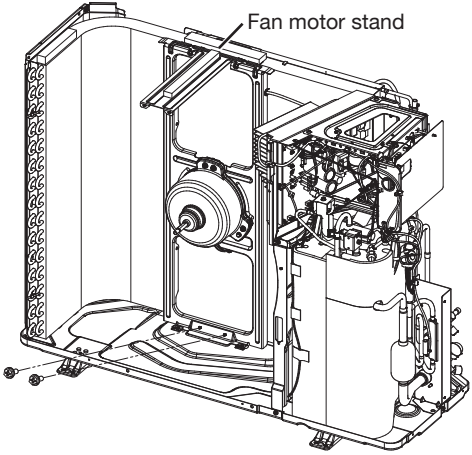
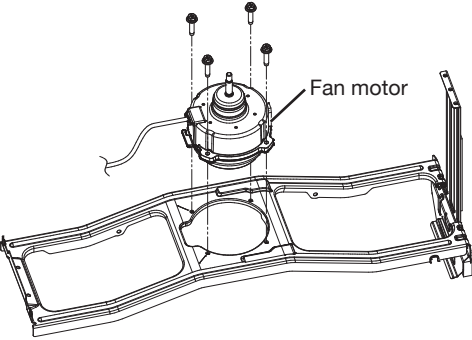
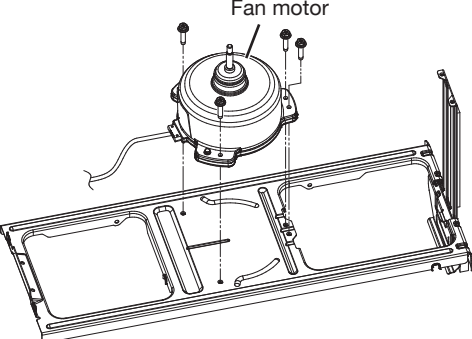
Step	Procedure	Points
4	<p>Remove 2 screws and remove the fan motor stand.</p> <p>■ 1.5/2.0 ton</p>  <p>■ 2.5/3.0 ton and 2.0 ton Enhanced Capacity/High Efficiency models</p> 	
5	<p>Remove 4 screws and remove the fan motor.</p> <p>■ 1.5/2.0 ton</p>  <p>■ 2.5/3.0 ton and 2.0 ton Enhanced Capacity/High Efficiency models</p> 	<p>■ The screws for fan motor are hexagon head tapping screws (M5 × 25).</p>

# REMOVAL & REASSEMBLY PROCEDURE

1.5 - 3.0 ton models HP & AC and 2.0 ton HP Enhanced Capacity and 2.0 ton AC High Efficiency models

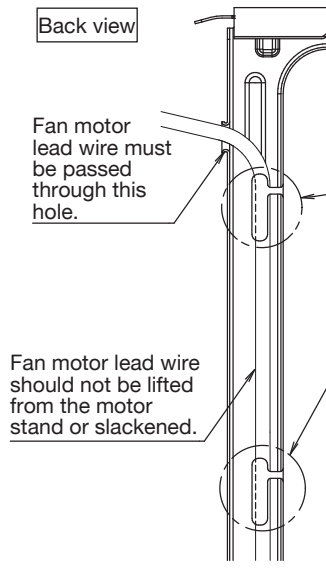
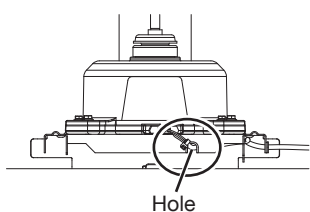
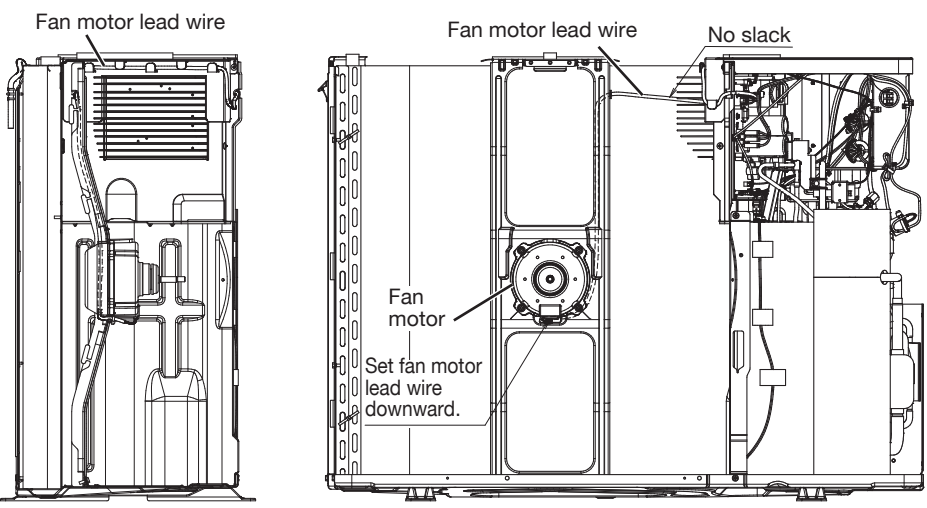
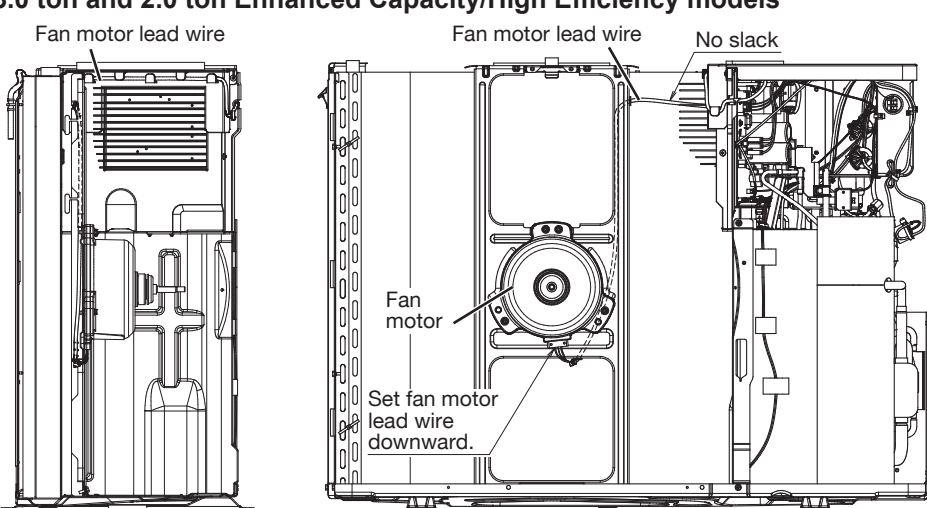
Step	Procedure	Points
	<p><b>Back view</b></p>  <p>Fan motor lead wire must be passed through this hole.</p> <p>Bend the claw of fan motor stand as shown. Then fix the lead wire. (2 places)</p> <p>Fan motor lead wire should not be lifted from the motor stand or slackened.</p>	<ul style="list-style-type: none"> <li>■ When reassembling follow the instructions.</li> <li>■ For 2.5/3.0 ton models and 2.0 ton Enhanced Capacity/High Efficiency models, be sure to pass the fan motor lead wire through the hole.</li> </ul> <p><b>Bottom view</b></p>  <p>Hole</p>
	<p>■ <b>1.5/2.0 ton</b></p>  <p>Fan motor lead wire</p> <p>Fan motor lead wire</p> <p>No slack</p> <p>Fan motor</p> <p>Set fan motor lead wire downward.</p>	
	<p>■ <b>2.5/3.0 ton and 2.0 ton Enhanced Capacity/High Efficiency models</b></p>  <p>Fan motor lead wire</p> <p>Fan motor lead wire</p> <p>No slack</p> <p>Fan motor</p> <p>Set fan motor lead wire downward.</p>	

# REMOVAL & REASSEMBLY PROCEDURE

1.5 - 3.0 ton models HP and 2.0 ton HP Enhanced Capacity and 2.0 ton AC High Efficiency models only

## 3. Wiring (for HP models and 2.0 ton AC High Efficiency models)

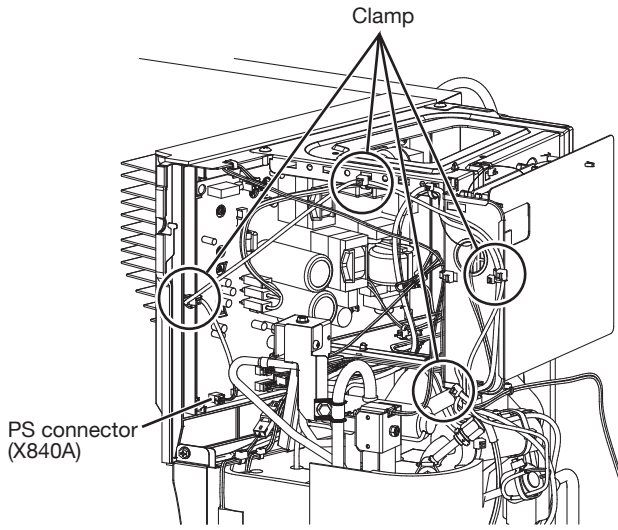
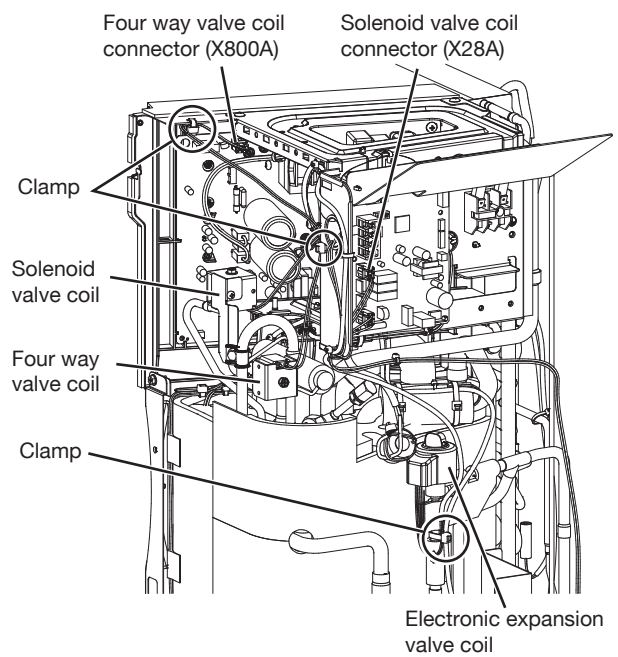
Step	Procedure	Points	
1	Cut the 4 clamps and disconnect the PS lead wire.	 <p>Clamp</p> <p>PS connector (X840A)</p>	<ul style="list-style-type: none"> <li>■ When reassembling, fix the lead wire to the same position with new clamps to prevent malfunction.</li> </ul>
2	Cut the 3 clamps and disconnect the four way valve coil lead wire and solenoid valve coil lead wire.	 <p>Four way valve coil connector (X800A)</p> <p>Solenoid valve coil connector (X28A)</p> <p>Clamp</p> <p>Solenoid valve coil</p> <p>Four way valve coil</p> <p>Clamp</p> <p>Electronic expansion valve coil</p>	

# REMOVAL & REASSEMBLY PROCEDURE

1.5 - 3.0 ton models HP and 2.0 ton HP Enhanced Capacity and 2.0 ton AC High Efficiency models only

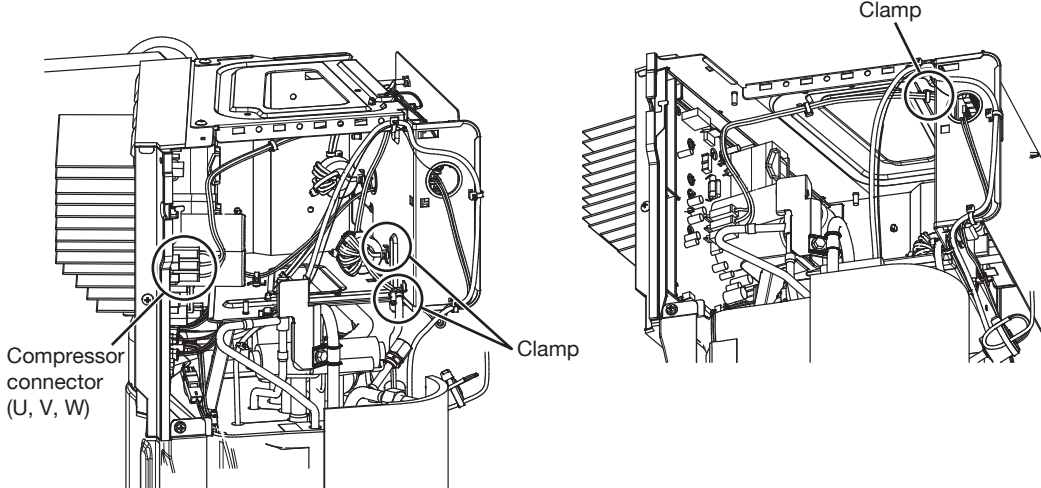
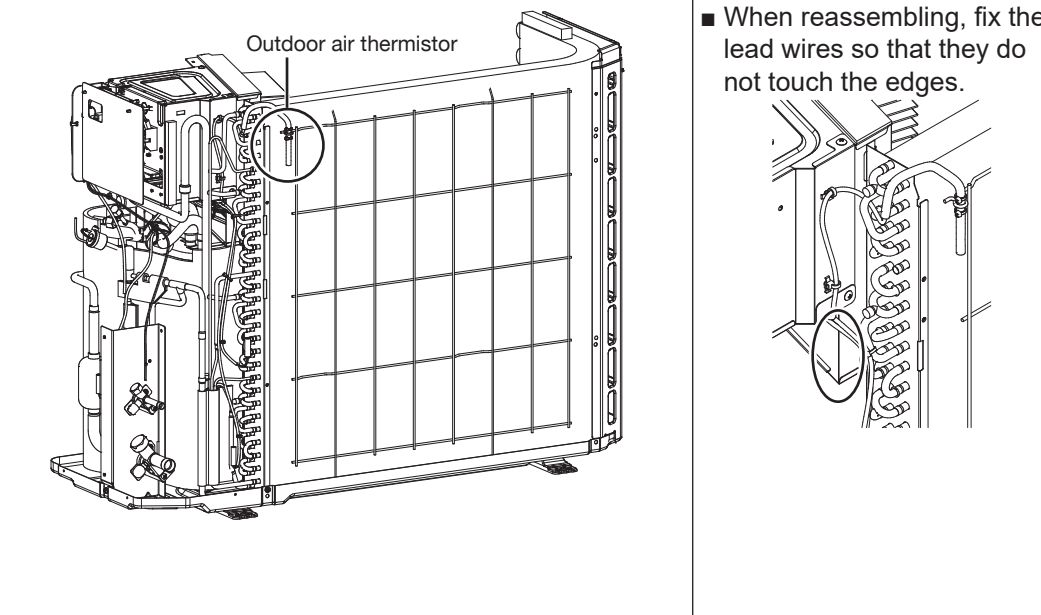
Step	Procedure	Points
3	<p>Remove 2 screws and remove the solenoid valve coil.</p> <p>Remove 1 screw and remove the four way valve coil.</p> <p>Pull out the electronic expansion valve coil.</p>	<ul style="list-style-type: none"> <li>■ Four way valve coil Tightening torque: 3.2±0.8 N·m (2.36±0.59 lb·ft) (M5 × 6.5).</li> <li>■ Solenoid valve coil Tightening torque: 1.47-1.96 N·m (1.08-1.45 lb·ft) (M4 × 6).</li> </ul>
4	<p>Remove the 3 clamps and disconnect the compressor lead wire.</p>	
5	<p>Remove the outdoor air thermistor and outdoor heat exchanger thermistor.</p> <p>Remove the defrost thermistor.</p>	<ul style="list-style-type: none"> <li>■ When reassembling, fix the lead wires so that they do not touch the edges.</li> </ul> 

# REMOVAL & REASSEMBLY PROCEDURE

1.5 - 3.0 ton models HP and 2.0 ton HP Enhanced Capacity and 2.0 ton AC High Efficiency models only

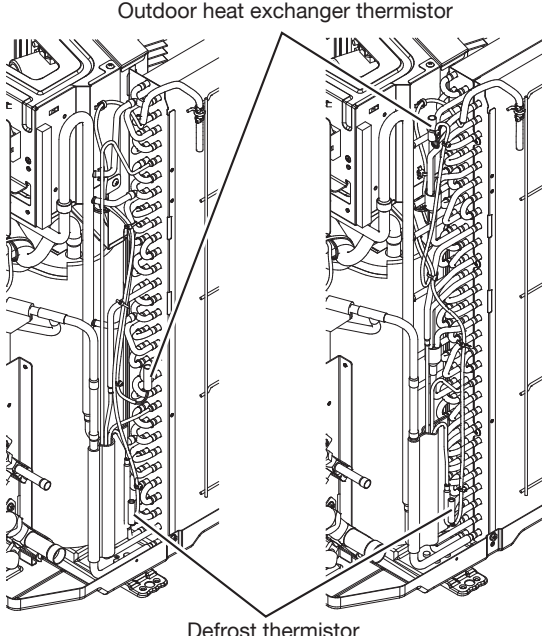
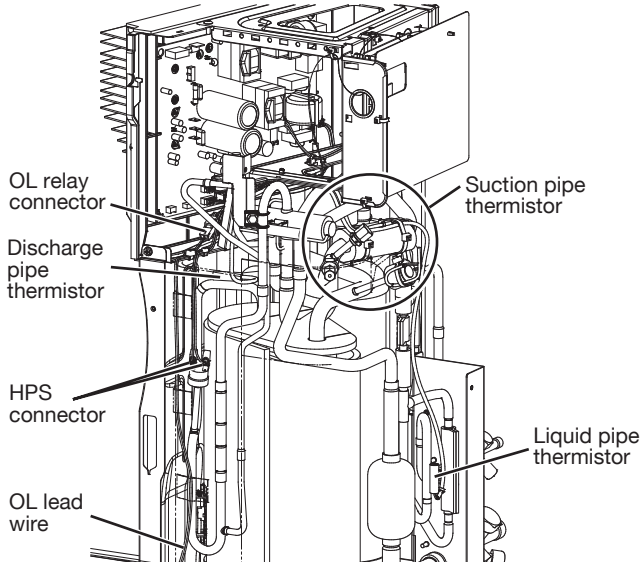
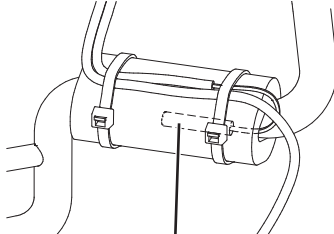
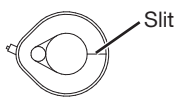
Step	Procedure	Points
<p>6 Remove the suction pipe thermistor, discharge pipe thermistor and liquid pipe thermistor.</p> <p>Detach the OL (overload protector) relay connector and HPS connectors.</p>	<p>■ 1.5/2.0/2.5 ton models      ■ 3.0 ton and 2.0 ton Enhanced Capacity/ High Efficiency models</p> <p>Outdoor heat exchanger thermistor</p>  <p>Defrost thermistor</p>  <p>OL relay connector      Suction pipe thermistor</p> <p>Discharge pipe thermistor</p> <p>HPS connector      Liquid pipe thermistor</p> <p>OL lead wire</p>	<p>■ Cut the 2 clamps and remove the insulation tube.</p>  <p>Suction pipe thermistor</p> <p>■ When reassembling, the slit of the insulation tube must be positioned opposite to the suction pipe thermistor.</p>  <p>Slit</p> <p>■ The HPS is inside the sound blanket (outer body).</p>

# REMOVAL & REASSEMBLY PROCEDURE

1.5 to 3.0 ton  
AC only

## 4. Wiring (for AC models)

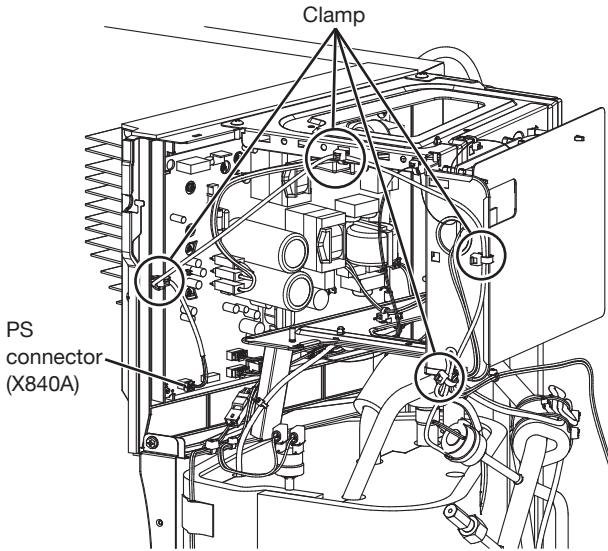
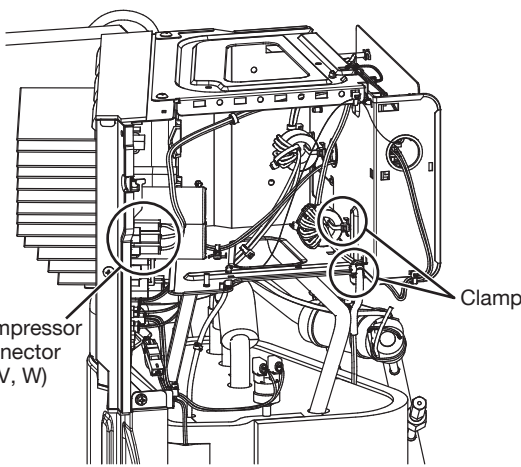
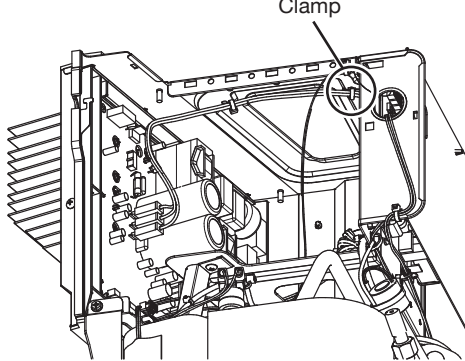
Step		Procedure	Points
1	Cut the 4 clamps and disconnect the PS lead wire.	 <p>Clamp</p> <p>PS connector (X840A)</p>	<ul style="list-style-type: none"> <li>■ When reassembling, fix the lead wire to the same position with new clamps to prevent malfunction.</li> </ul>
2	Remove the 3 clamps and disconnect the compressor lead wire.	 <p>Clamp</p> <p>Compressor connector (U, V, W)</p>	 <p>Clamp</p>

# REMOVAL & REASSEMBLY PROCEDURE

1.5 to 3.0 ton  
AC only

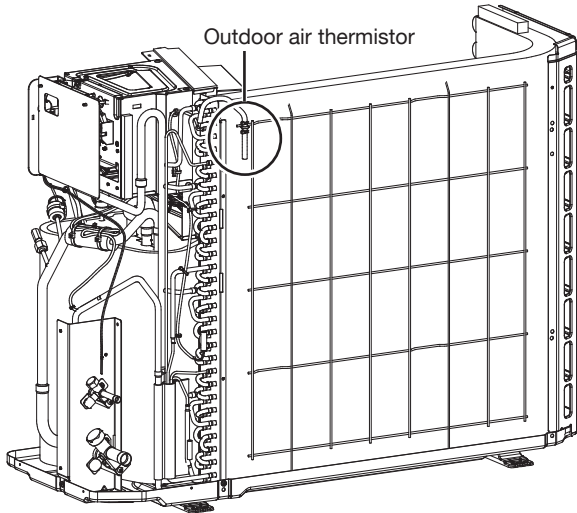
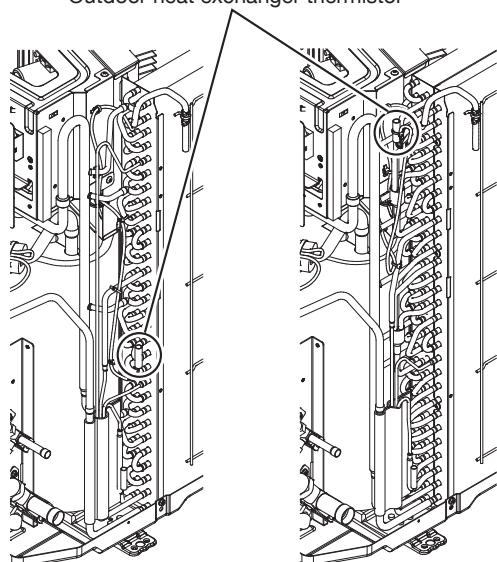
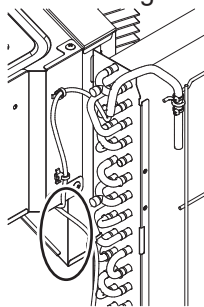
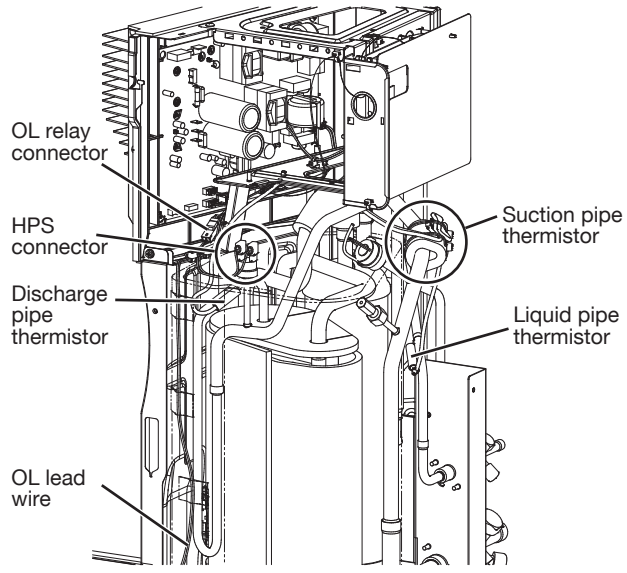
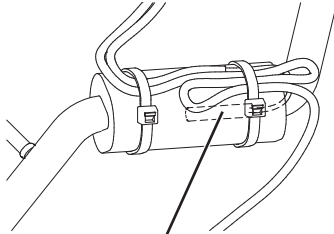
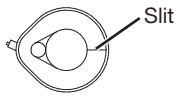
Step	Procedure	Points
3	<p>Remove the outdoor air thermistor and outdoor heat exchanger thermistor.</p>  <p>Outdoor air thermistor</p> <p>■ 1.5/2.0/2.5 ton      ■ 3.0 ton</p> <p>Outdoor heat exchanger thermistor</p> 	<p>■ When reassembling, fix the lead wires so that they do not touch the edges.</p> 
4	<p>Remove the suction pipe thermistor, discharge pipe thermistor and liquid pipe thermistor.</p> <p>Detach the OL (overload protector) relay connector and HPS connectors.</p>  <p>OL relay connector</p> <p>HPS connector</p> <p>Discharge pipe thermistor</p> <p>OL lead wire</p> <p>Suction pipe thermistor</p> <p>Liquid pipe thermistor</p>	<p>■ Cut the 2 clamps and remove the insulation tube.</p>  <p>Suction pipe thermistor</p> <p>■ When reassembling, the slit of the insulation tube must be positioned opposite to the suction pipe thermistor.</p>  <p>Slit</p>

# REMOVAL & REASSEMBLY PROCEDURE

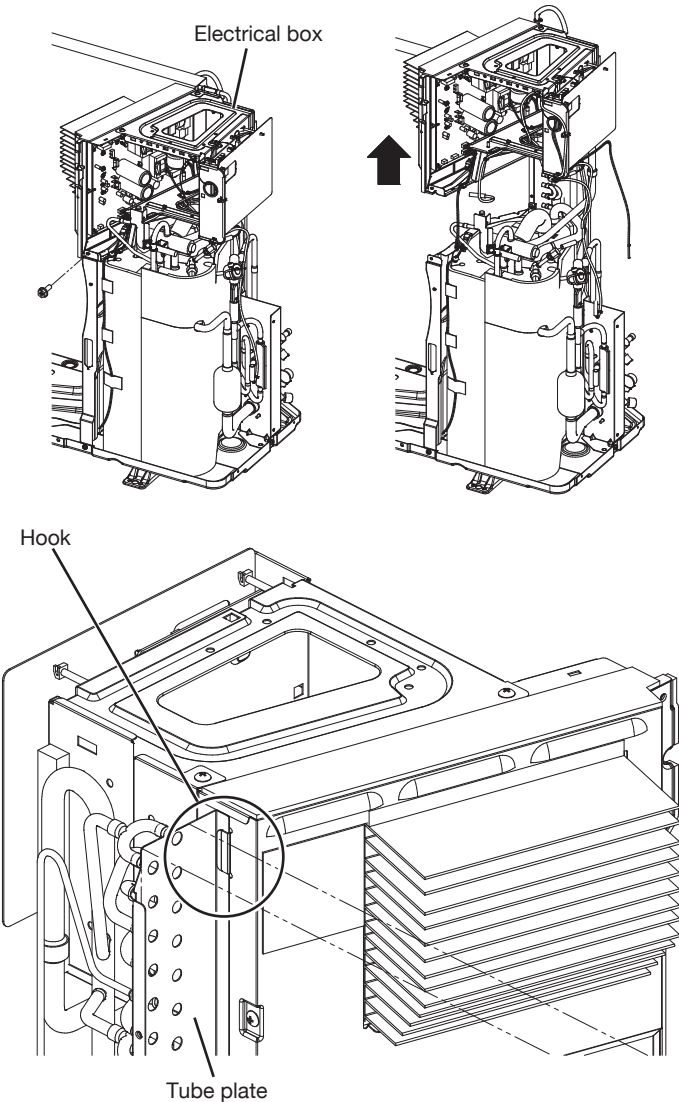
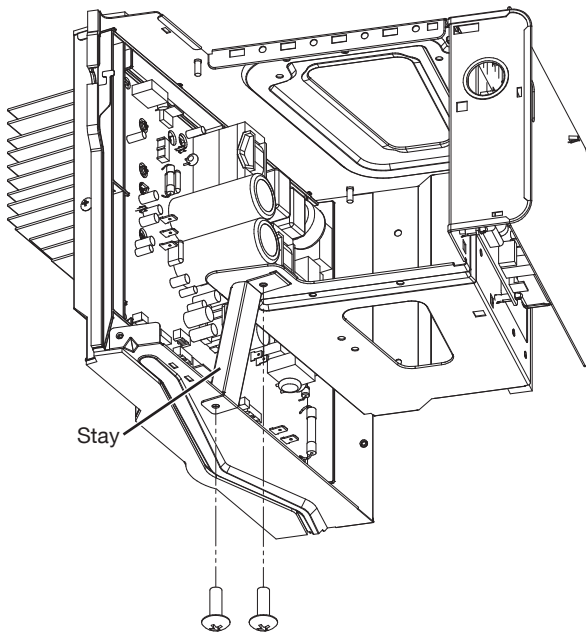

1.5 - 3.0 ton models HP & AC and 2.0 ton HP Enhanced Capacity and 2.0 ton AC High Efficiency models

## 5. Electrical box and PCB

Step	Procedure	Points
1	<p data-bbox="188 219 440 314">Remove 1 screw and remove the electrical box.</p>  <p data-bbox="673 240 803 261">Electrical box</p> <p data-bbox="500 751 557 772">Hook</p> <p data-bbox="646 1304 751 1325">Tube plate</p>	<p data-bbox="1185 744 1539 804">■ The electrical box is fixed to the tube plate by a hook.</p>
2	<p data-bbox="188 1368 451 1427">Remove 2 screws and remove the stay.</p>  <p data-bbox="600 1793 649 1815">Stay</p>	<p data-bbox="1185 1368 1547 1491">■ The screws of stay are truss head tapping screws or truss head machine screw (M4 × 12).</p>

# REMOVAL & REASSEMBLY PROCEDURE

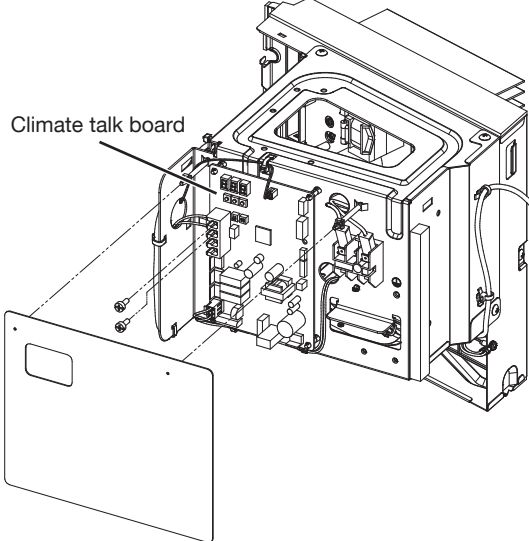
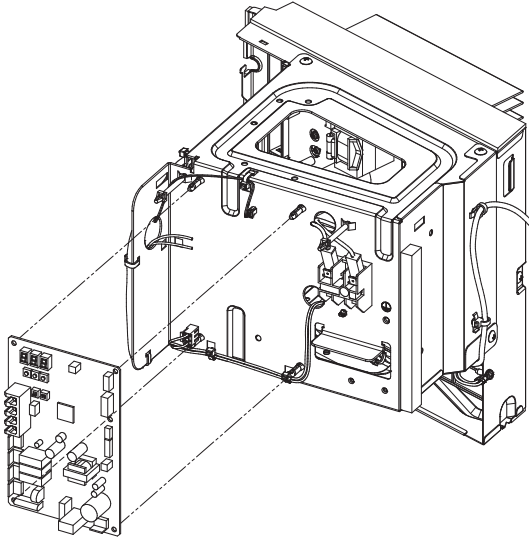
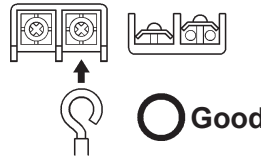
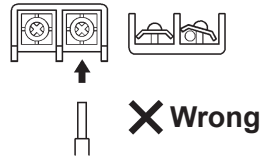
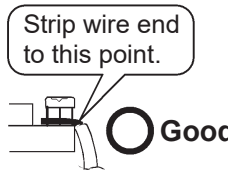
1.5 - 3.0 ton models HP & AC and 2.0 ton HP Enhanced Capacity and 2.0 ton AC High Efficiency models

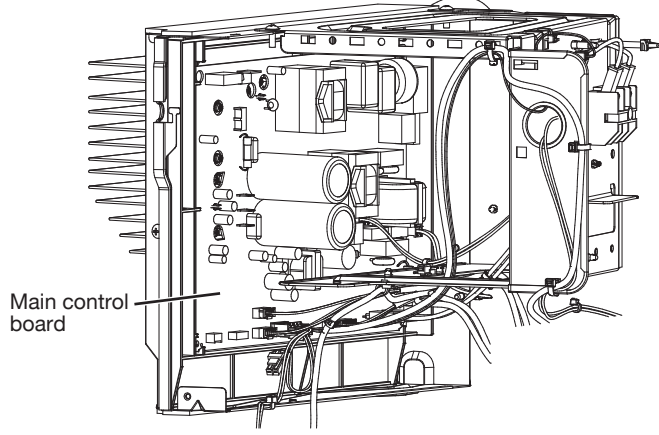
Step	Procedure	Points
3	<p>Disconnect the wires on climate talk board (functional module), and then remove the board.</p>  	<p>■ When reassembling, be sure to curl the end of the lead and fix the screw with the following torque. Tightening torque: 0.65-0.79 lb·ft (0.88-1.07 N·m)</p>   <p>Strip wire end to this point.</p>  
4	<p>Disconnect all the connectors on the main control board.</p> 	

# REMOVAL & REASSEMBLY PROCEDURE

1.5 - 3.0 ton models HP & AC and 2.0 ton HP Enhanced Capacity and 2.0 ton AC High Efficiency models

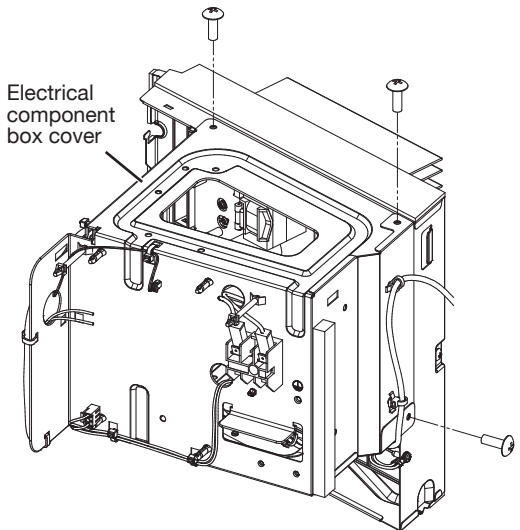
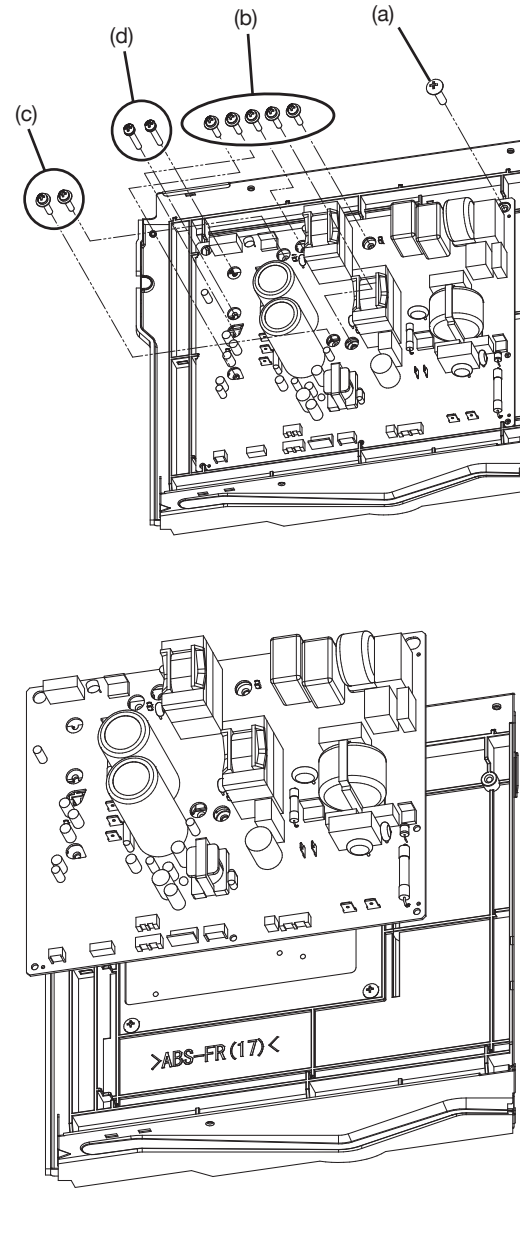
Step	Procedure	Procedure	Points
5	Remove 3 screws and remove the electrical component box cover.	 <p>Electrical component box cover</p>	<ul style="list-style-type: none"> <li>■ The screws of the electrical component box cover are truss head tapping screws or truss head machine screw (M4 × 12).</li> </ul>
6	Remove 10 screws and remove the main control board.		<ul style="list-style-type: none"> <li>■ The main control board screws are:               <ul style="list-style-type: none"> <li>(a) Truss head tapping screw 1 pc: M4 × 16</li> <li>(b) Pan head machine screw 5 pc: M3 × 16 or M3 × 20</li> <li>(c) Pan head machine screw 2 pc: M3 × 16 or M3 × 20</li> <li>(d) Pan head machine screw 2 pc: M3 × 20</li> </ul> </li> <li>■ When reassembling, fix the screw with the following torque.               <p>Tightening torque:</p> <ul style="list-style-type: none"> <li>(a) 0.86-1.01 lb·ft (1.17-1.37 N·m)</li> <li>(b) 0.43-0.57 lb·ft (0.58-0.77 N·m)</li> <li>(c) 0.36-0.50 lb·ft (0.49-0.68 N·m)</li> <li>(d) 0.22-0.37 lb·ft (0.30-0.50 N·m)</li> </ul> </li> </ul>

# REMOVAL & REASSEMBLY PROCEDURE

1.5 - 3.0 ton models HP and 2.0 ton HP Enhanced Capacity and 2.0 ton AC High Efficiency models only

## 6. Sound blankets and Compressor (for HP models and 2.0 ton AC High Efficiency models)

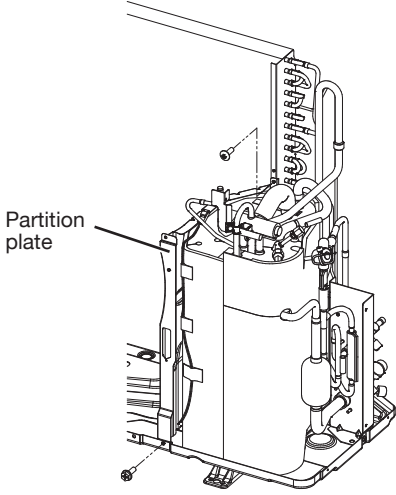
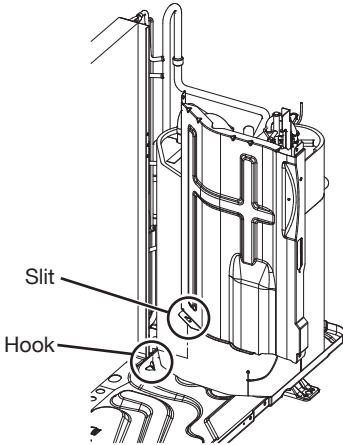
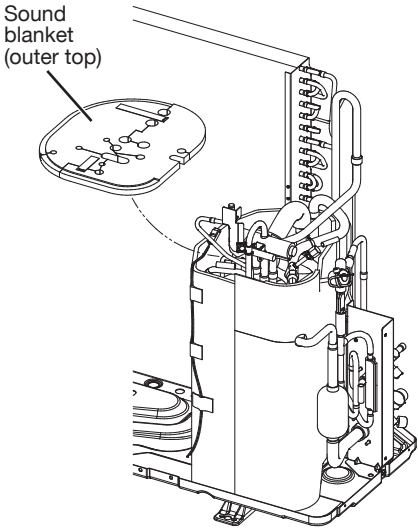
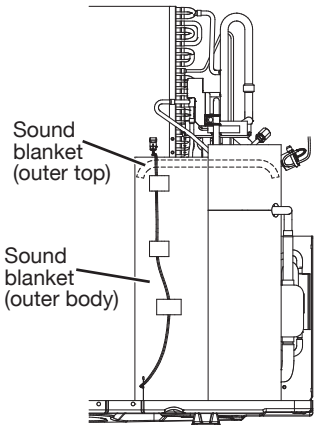
Step	Procedure	Points	
1	<p>Remove 2 screws and remove the partition plate.</p>	 	<ul style="list-style-type: none"> <li>■ The upper screw is a truss head tapping screw or a hex head screw (M4 × 12).</li> <li>■ When reassembling, insert the hook of the bottom frame into the slit of the partition plate.</li> </ul>
2	<p>Remove the sound blanket (outer top).</p>	  <ul style="list-style-type: none"> <li>■ When reassembling, all of the circumference of the sound blanket (outer top) should be inserted in the sound blanket (outer body). Make sure the sound blanket (outer top) does not rise above the sound blanket (outer body).</li> </ul>	

# REMOVAL & REASSEMBLY PROCEDURE

1.5 - 3.0 ton models HP and 2.0 ton HP Enhanced Capacity and 2.0 ton AC High Efficiency models only

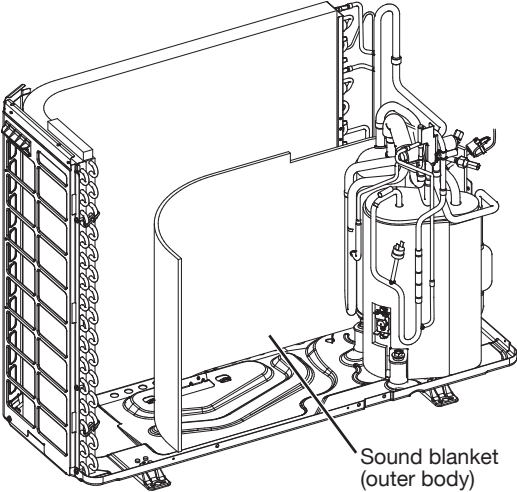
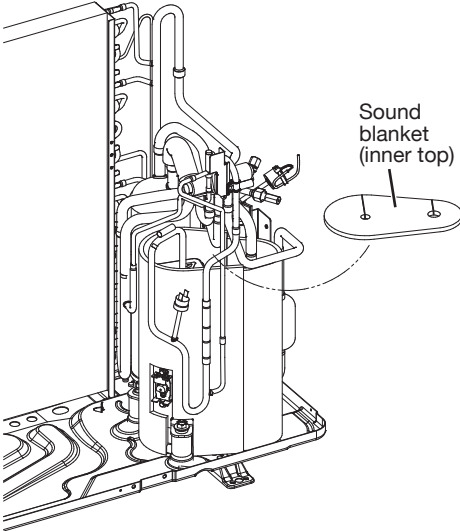
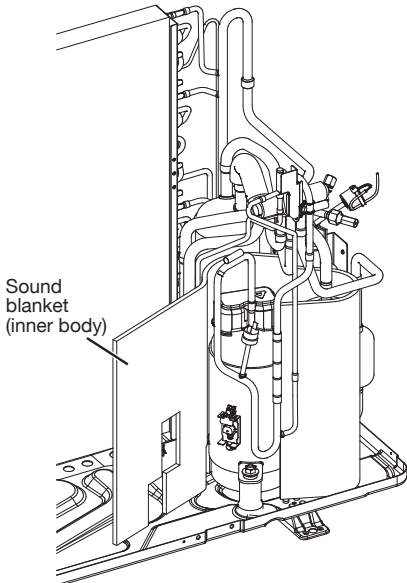
Step	Procedure	Points	
3	Remove the sound blanket (outer body).	 <p>Sound blanket (outer body)</p>	
4	Remove the sound blanket (inner top).	 <p>Sound blanket (inner top)</p>	<ul style="list-style-type: none"> <li>■ The illustration is for 2.0 ton model as representative.</li> </ul>
5	Remove the sound blanket (inner body).	 <p>Sound blanket (inner body)</p>	<ul style="list-style-type: none"> <li>■ The illustration is for 2.0 ton model as representative.</li> </ul>

# REMOVAL & REASSEMBLY PROCEDURE

1.5 - 3.0 ton models HP and 2.0 ton HP Enhanced Capacity and 2.0 ton AC High Efficiency models only

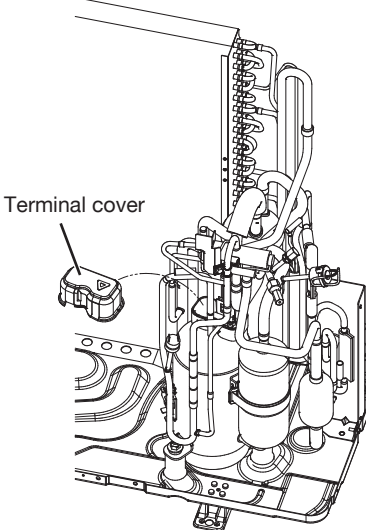
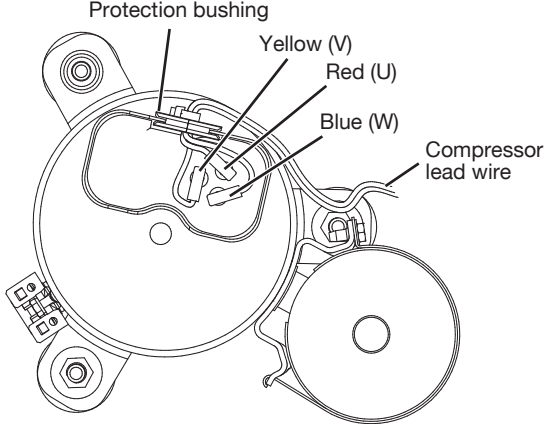
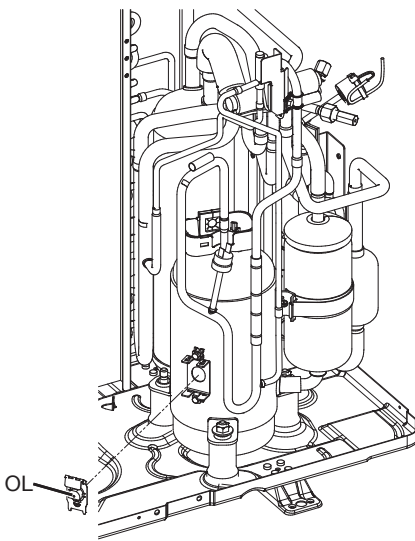
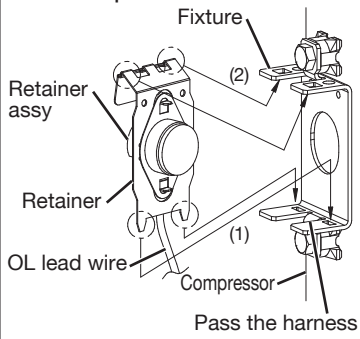
Step	Procedure	Points
6	<p>Remove the terminal cover.</p>  <p>Terminal cover</p>	<p>■ The illustration is for 2.0 ton model as representative.</p>
7	<p>Disconnect the compressor lead wire.</p>  <p>Protection bushing Yellow (V) Red (U) Blue (W) Compressor lead wire</p>	<p>■ The illustration is for 2.0 ton model as representative.</p>
8	<p>Remove the OL.</p>  <p>OL</p>	<p>■ When reassembling, attach the OL as shown below.</p> <ol style="list-style-type: none"> <li>(1) Insert lower hooks of retainer into the square holes of fixture.</li> <li>(2) Push upper hooks of retainer until they hook in the square holes of fixture.</li> </ol>  <p>Fixture Retainer assy Retainer OL lead wire Compressor Pass the harness</p>

# REMOVAL & REASSEMBLY PROCEDURE

1.5 - 3.0 ton models HP and 2.0 ton HP Enhanced Capacity and 2.0 ton AC High Efficiency models only

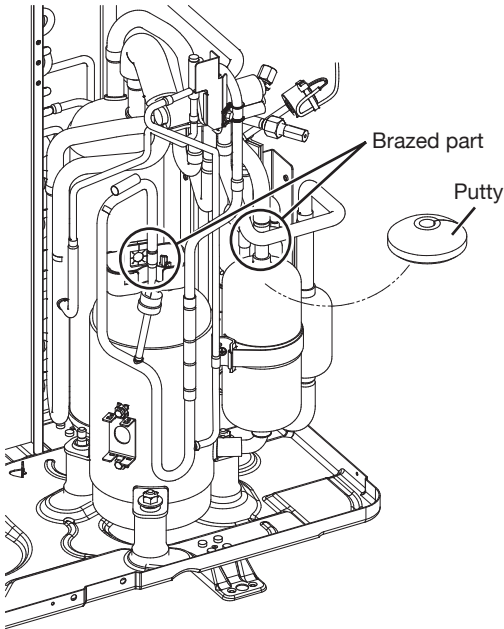
Step	Procedure	Points
9	<p data-bbox="185 165 451 293">Heat up the brazed parts of compressor piping and disconnect them.</p> 	<ul style="list-style-type: none"><li data-bbox="1182 165 1550 229">■ The illustration is for 2.0 ton model as representative.</li><li data-bbox="1182 263 1550 527">■ Before working, be sure to remove any putties, the terminal cover, and other plastic pieces that may burn. Also, provide a protective sheet or a steel plate so that the brazing flame cannot influence peripheries.</li></ul>

# REMOVAL & REASSEMBLY PROCEDURE

1.5 to 3.0 ton  
AC only

## 7. Sound blankets and Compressor (for AC models)

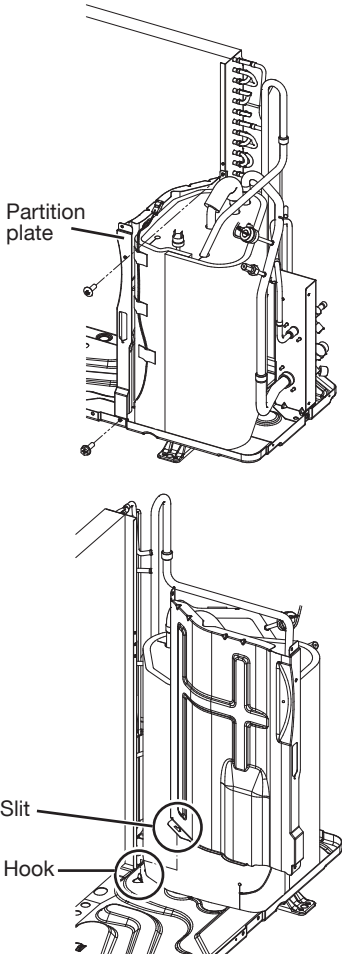
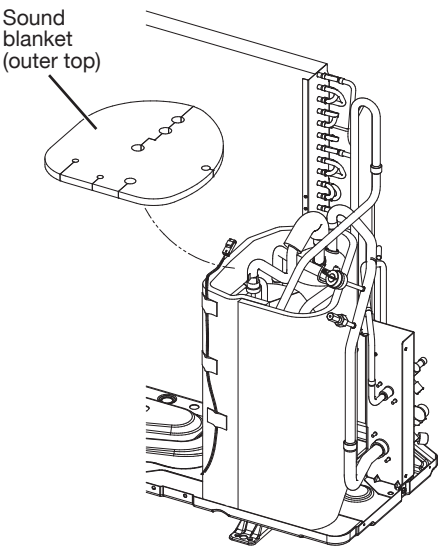
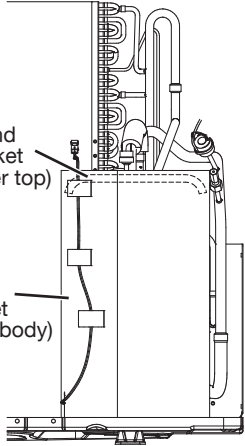
Step	Procedure	Points
1	<p>Remove 2 screws and remove the partition plate.</p>  <p>Partition plate</p> <p>Slit</p> <p>Hook</p>	<ul style="list-style-type: none"> <li>■ The upper screw is a truss head tapping screw or a hex head screw (M4 × 12).</li> <li>■ When reassembling, insert the hook of the bottom frame into the slit of the partition plate.</li> </ul>
2	<p>Remove the sound blanket (outer top).</p>  <p>Sound blanket (outer top)</p> <p>Sound blanket (outer top)</p> <p>Sound blanket (outer body)</p>	<ul style="list-style-type: none"> <li>■ When reassembling, all of the circumference of the sound blanket (outer top) should be inserted in the sound blanket (outer body). Make sure the sound blanket (outer top) does not rise above the sound blanket (outer body).</li> </ul>  <p>Sound blanket (outer top)</p> <p>Sound blanket (outer body)</p>

# REMOVAL & REASSEMBLY PROCEDURE

1.5 to 3.0 ton  
AC only

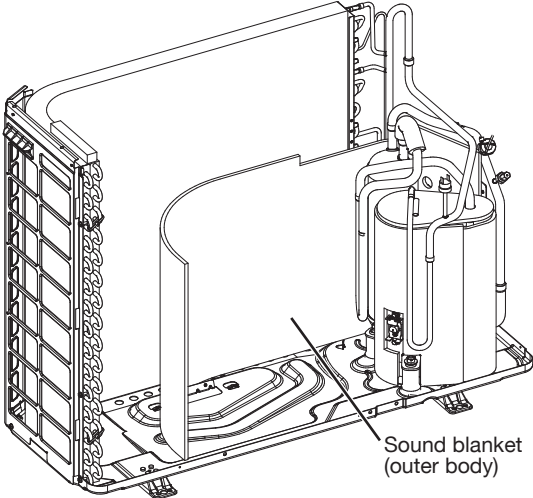
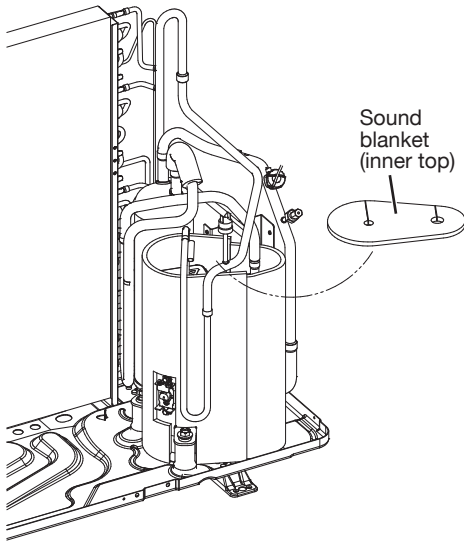
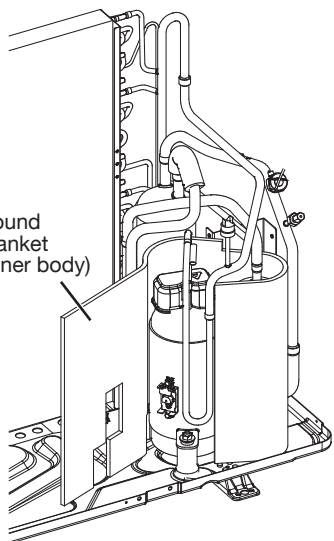
Step	Procedure	Points
3	<p>Remove the sound blanket (outer body).</p>  <p>Sound blanket (outer body)</p>	
4	<p>Remove the sound blanket (inner top).</p>  <p>Sound blanket (inner top)</p>	<p>■ The illustration is for 2 ton model as representative.</p>
5	<p>Remove the sound blanket (inner body).</p>  <p>Sound blanket (inner body)</p>	<p>■ The illustration is for 2 ton model as representative.</p>

# REMOVAL & REASSEMBLY PROCEDURE

1.5 to 3.0 ton  
AC only

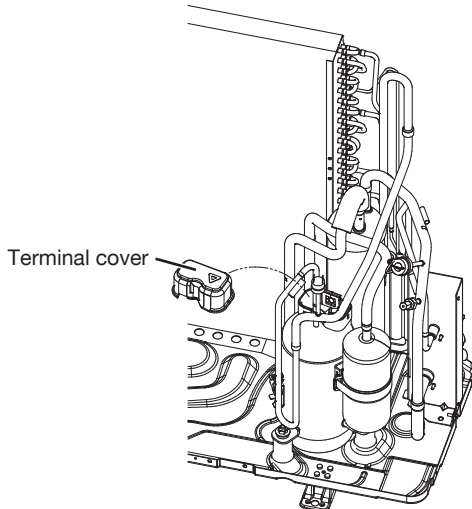
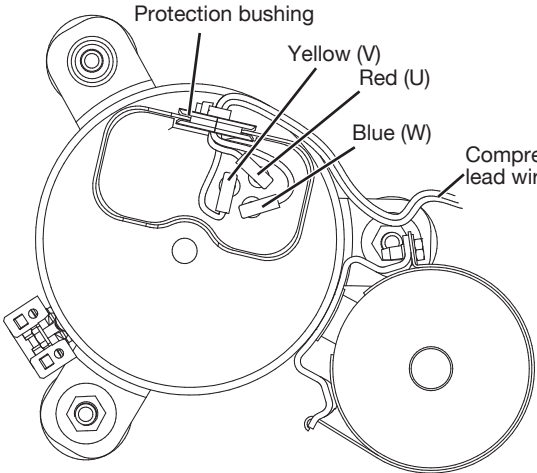
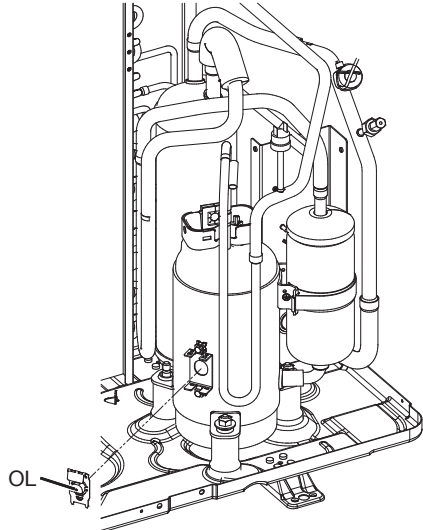
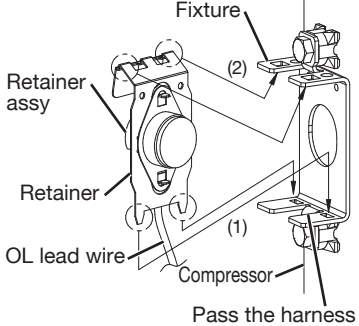
Step	Procedure	Points	
6	Remove the terminal cover.	 <p>Terminal cover</p>	<ul style="list-style-type: none"> <li>■ The illustration is for 2 ton model as representative.</li> </ul>
7	Disconnect the compressor lead wire.	 <p>Protection bushing Yellow (V) Red (U) Blue (W) Compressor lead wire</p>	<ul style="list-style-type: none"> <li>■ The illustration is for 2 ton model as representative.</li> </ul>
8	Remove the OL.	 <p>OL</p>	<ul style="list-style-type: none"> <li>■ When reassembling, attach the OL as shown below.</li> <li>(1) Insert lower hooks of retainer into the square holes of fixture.</li> <li>(2) Push upper hooks of retainer until they hook in the square holes of fixture.</li> </ul>  <p>Fixture Retainer assy Retainer OL lead wire Compressor Pass the harness</p>

# REMOVAL & REASSEMBLY PROCEDURE

1.5 to 3.0 ton  
AC only

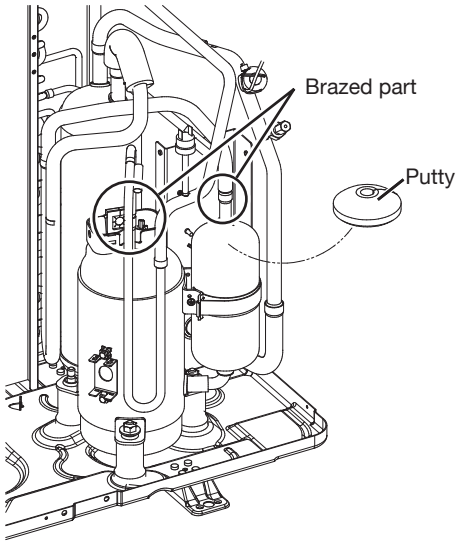
Step	Procedure	Points
9	<p data-bbox="185 165 451 293">Heat up the brazed parts of compressor piping and disconnect them.</p>  <p>The diagram shows a compressor unit with various pipes and components. A callout line points to a specific joint on the piping labeled 'Brazed part'. Another callout line points to a circular cap labeled 'Putty'.</p>	<ul style="list-style-type: none"><li data-bbox="1182 165 1516 229">■ The illustration is for 2 ton model as representative.</li><li data-bbox="1182 263 1549 519">■ Before working, be sure to remove any putties, the terminal cover, and other plastic pieces that may burn. Also, provide a protective sheet or a steel plate so that the brazing flame cannot influence peripheries.</li></ul>

# REMOVAL & REASSEMBLY PROCEDURE

1.5 - 3.0 ton models HP & AC and 2.0 ton HP Enhanced Capacity and 2.0 ton AC High Efficiency models

## 8. Heat exchanger

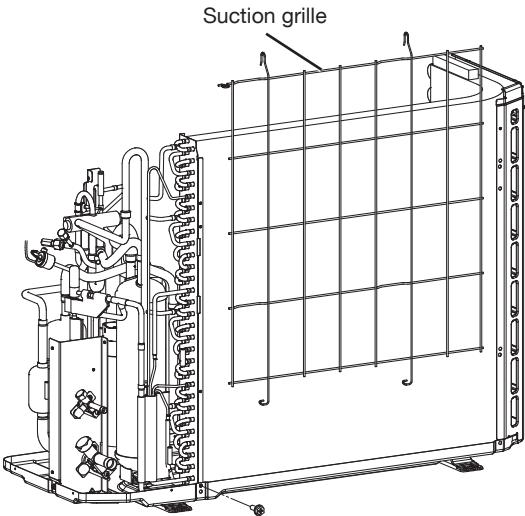
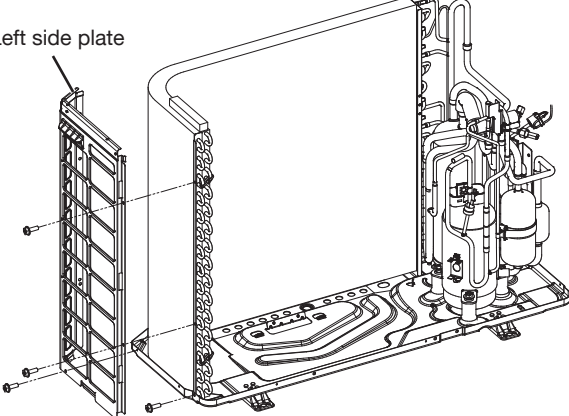
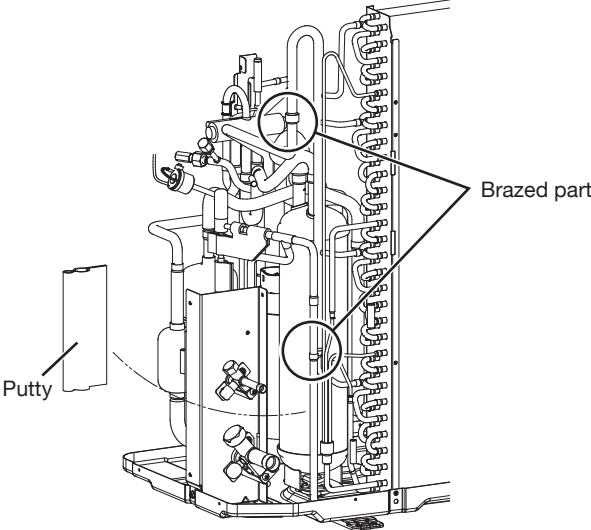
Step	Procedure	Points
1	<p>Remove the suction grille. Remove 1 screw.</p> 	
2	<p>Remove 4 screws and remove the left side plate.</p> 	
3	<p>Heat up the brazed parts and remove the heat exchanger.</p> 	<p>■ Before working, be sure to remove putty that may burn. Also, provide a protective sheet or a steel plate so that the brazing flame cannot influence peripheries.</p>

# REMOVAL & REASSEMBLY PROCEDURE

3.5 - 5.0 ton models HP & AC and 3.0 - 4.0 ton HP Enhanced Capacity and 3.0 - 4.0 ton AC High Efficiency models

## 3.5 - 5.0 ton models and 3.0 - 4.0 ton Enhanced Capacity/High Efficiency models

### 1. Panels

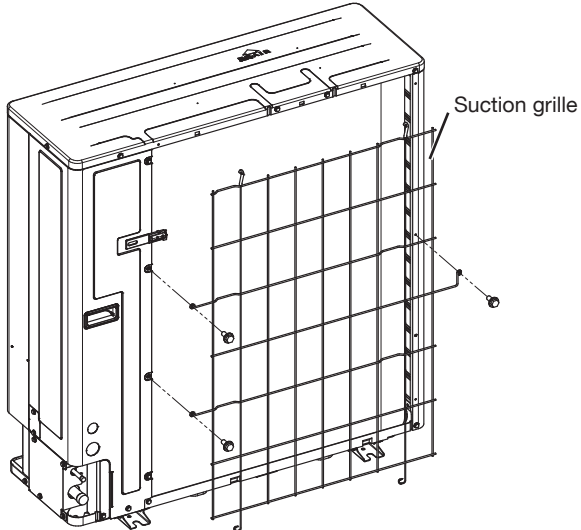
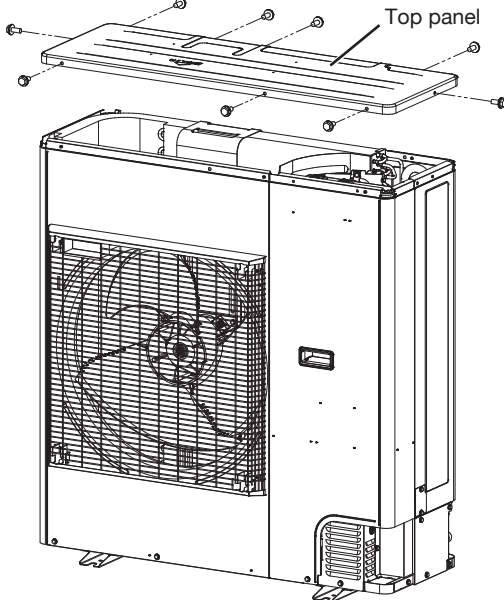
Step	Procedure	Procedure	Points
1	Remove 3 screws and remove the suction grille.		<ul style="list-style-type: none"><li>■ When reassembling, perform the procedures in inverse order.</li><li>■ All screws that are not mentioned are hexagon flanged screws (M5 × 12).</li></ul>
2	Remove 9 screws and remove the top panel.		

# REMOVAL & REASSEMBLY PROCEDURE

3.5 - 5.0 ton models HP & AC and 3.0 - 4.0 ton HP Enhanced Capacity and 3.0 - 4.0 ton AC High Efficiency models

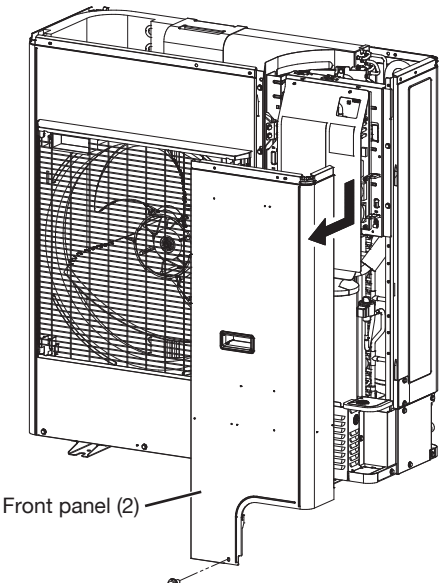
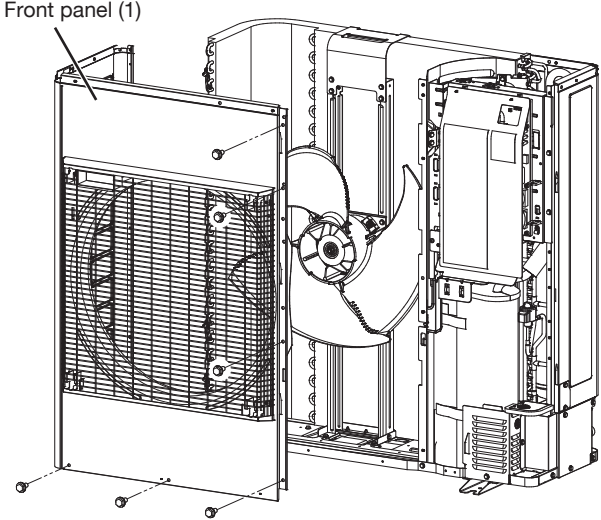
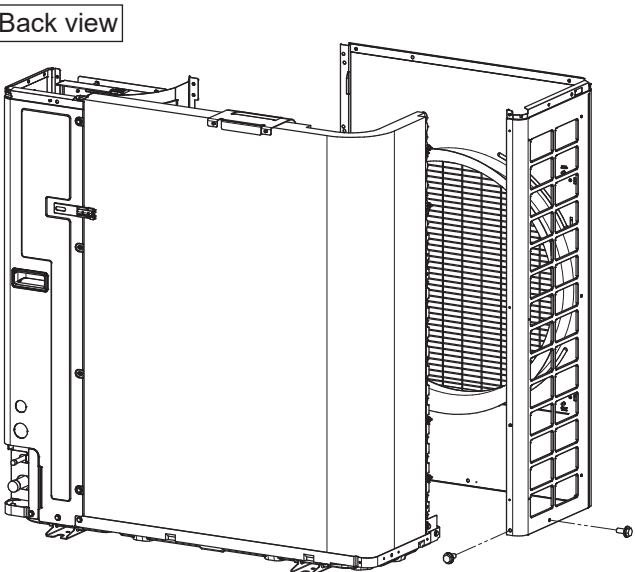
Step	Procedure	Points
3	<p>Remove 1 screw and push down to remove the front panel (2).</p>  <p>Front panel (2)</p>	
4	<p>Remove 8 screws and remove the front panel (1).</p>  <p>Front panel (1)</p> <p>Back view</p> 	

# REMOVAL & REASSEMBLY PROCEDURE

3.5 - 5.0 ton models HP & AC and 3.0 - 4.0 ton HP Enhanced Capacity and 3.0 - 4.0 ton AC High Efficiency models

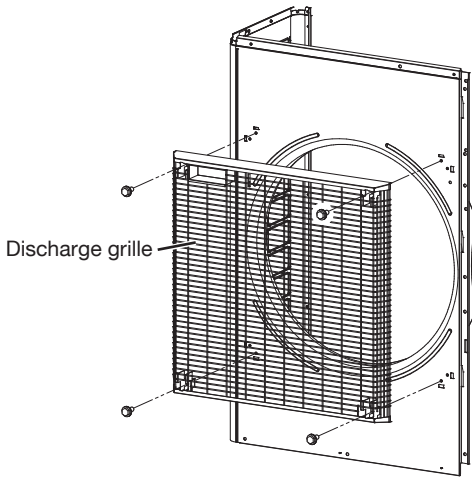
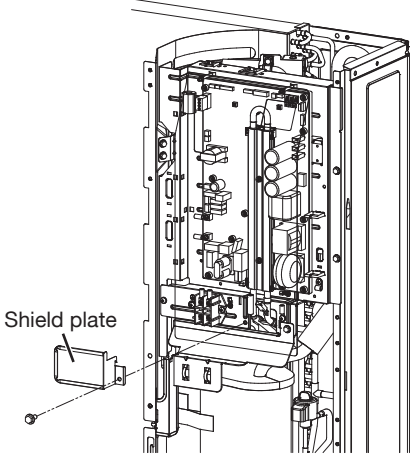
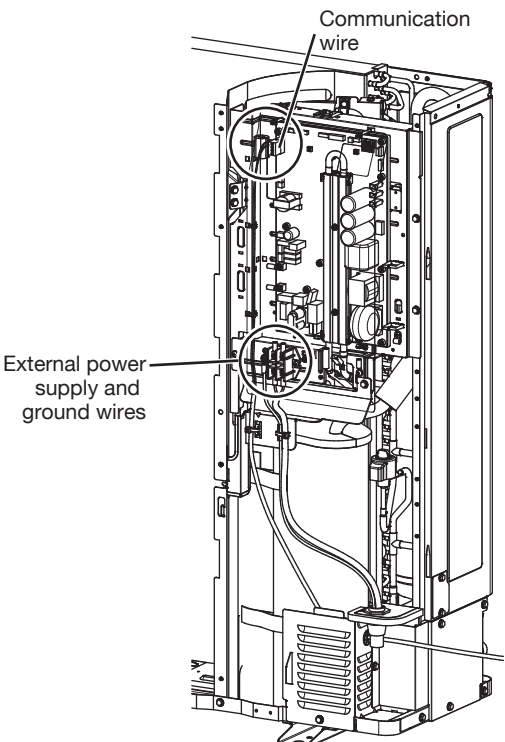
Step	Procedure	Procedure	Points
5	Remove 4 screws and remove the discharge grille.	 <p>Discharge grille</p>	
6	Remove 1 screw and remove the shield plate of terminal board.	 <p>Shield plate</p>	<ul style="list-style-type: none"> <li>■ The screw is a 3 class hexagon head tapping screw. Use the same screws when reassembling.</li> </ul>
7	Disconnect the external power supply, ground and communication wires.	 <p>Communication wire</p> <p>External power supply and ground wires</p>	

# REMOVAL & REASSEMBLY PROCEDURE

3.5 - 5.0 ton models HP & AC and 3.0 - 4.0 ton HP Enhanced Capacity and 3.0 - 4.0 ton AC High Efficiency models

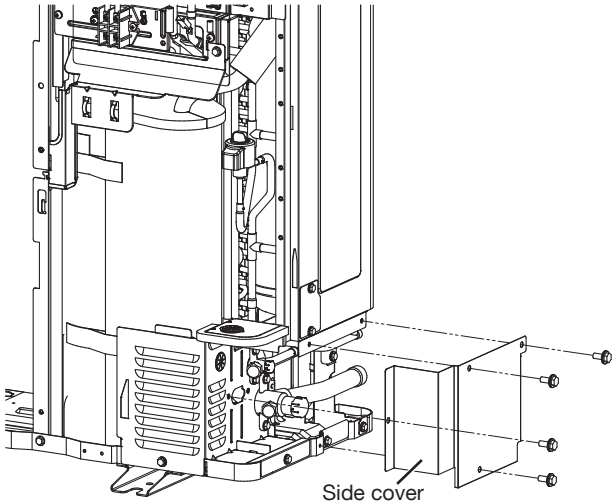
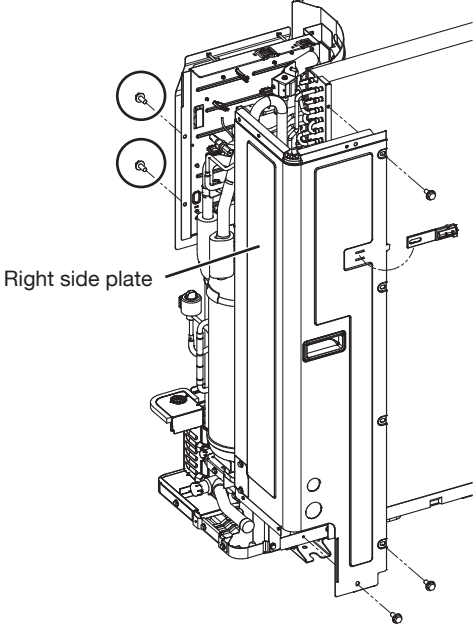
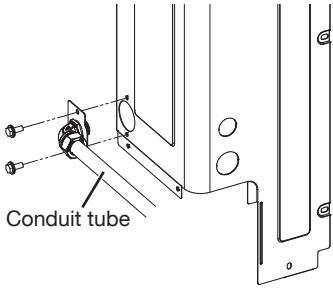
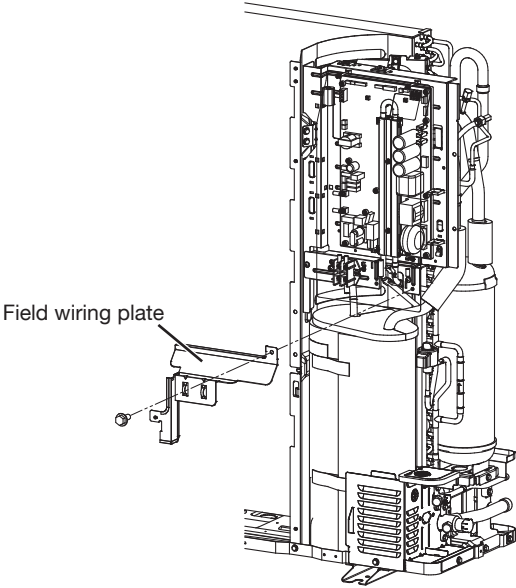
Step	Procedure	Procedure	Points
8	Remove 4 screws and remove the side cover.		
9	Remove 5 screws and remove the right side plate.		<ul style="list-style-type: none"> <li>■ The screws marked with circles are 3 class hexagon head tapping screws. Use the same screws when reassembling.</li> <li>■ Remove 2 screws and remove the conduit tube from patch plate if the conduit tube is connected.</li> </ul> 
10	Remove 1 screw and remove the field wiring plate.		<ul style="list-style-type: none"> <li>■ The screw is a 3 class hexagon head tapping screw. Use the same screw when reassembling.</li> </ul>

# REMOVAL & REASSEMBLY PROCEDURE

3.5 - 5.0 ton models HP & AC and 3.0 - 4.0 ton HP Enhanced Capacity and 3.0 - 4.0 ton AC High Efficiency models

## 2. Fan and Fan motor

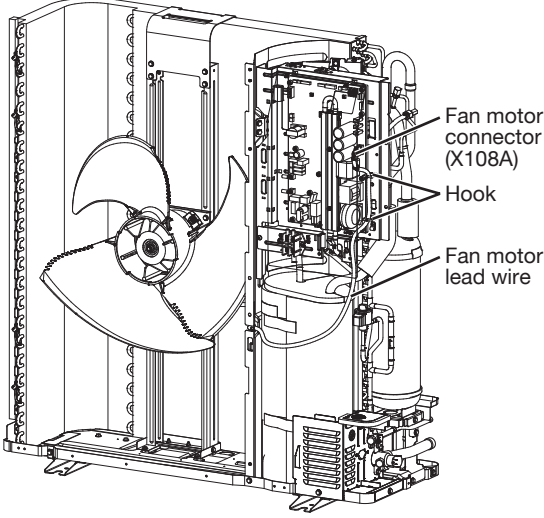
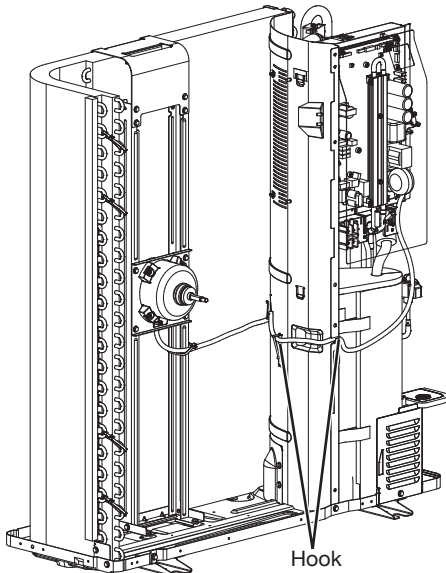
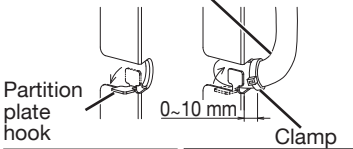
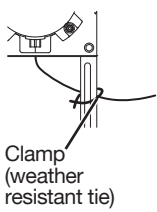
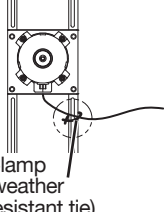
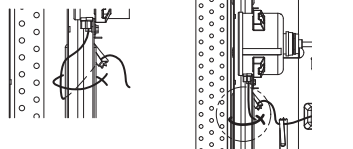
Step		Procedure	Points
1	Disconnect the fan motor connector and release the lead wire from the hooks.	 <p>Fan motor connector (X108A)</p> <p>Hook</p> <p>Fan motor lead wire</p>  <p>Hook</p>	<p>■ When reassembling, note the following points.</p> <p>Fan motor lead wire</p>  <p>Partition plate hook</p> <p>0~10 mm</p> <p>Clamp</p> <p>Lower the hook of the partition plate to let the fan motor lead wire pass through. After the lead wire is passed, return the hook.</p> <p>Make sure the fan motor lead wire is fixed tight. Clamp the lead wire at a maximum of 10 mm (0.4 in) from the partition plate.</p> <p>■ When reassembling, follow the illustration below to avoid entanglement with the outdoor fan.</p> <p>3.5/4.0 ton and 3.0 ton Enhanced Capacity/High Efficiency models (Pass behind the fan motor stand.)</p> <p>5.0 ton and 3.5 - 4.0 ton Enhanced Capacity/High Efficiency models (Pass in front of the fan motor stand.)</p>  <p>Clamp (weather resistant tie)</p>  <p>Clamp (weather resistant tie)</p> <p>■ When reassembling, use a weather resistant tie to clamp the fan motor lead wire to the motor stand.</p> 

# REMOVAL & REASSEMBLY PROCEDURE

3.5 - 5.0 ton models HP & AC and 3.0 - 4.0 ton HP Enhanced Capacity and 3.0 - 4.0 ton AC High Efficiency models

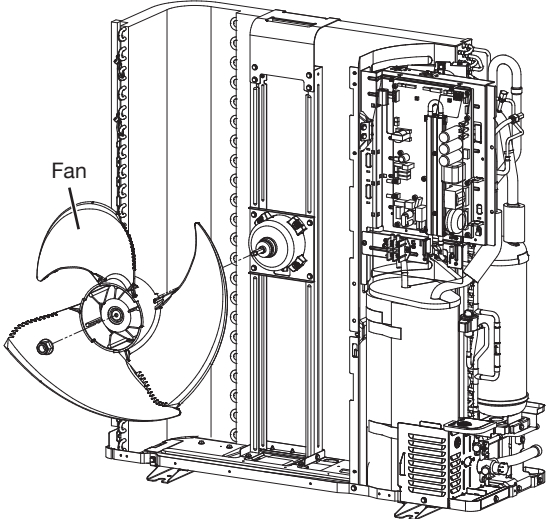
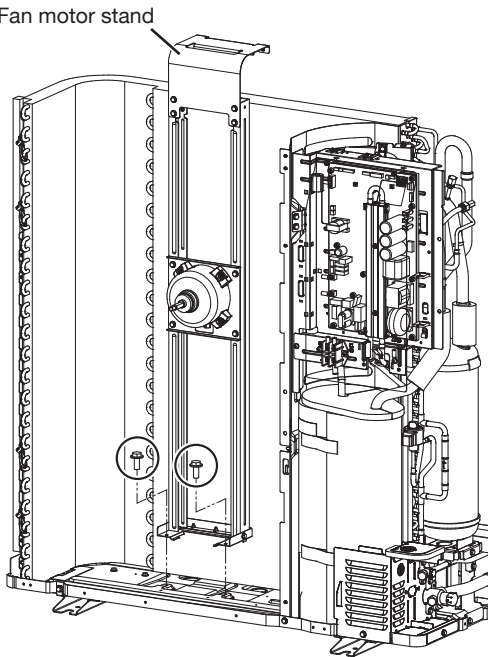
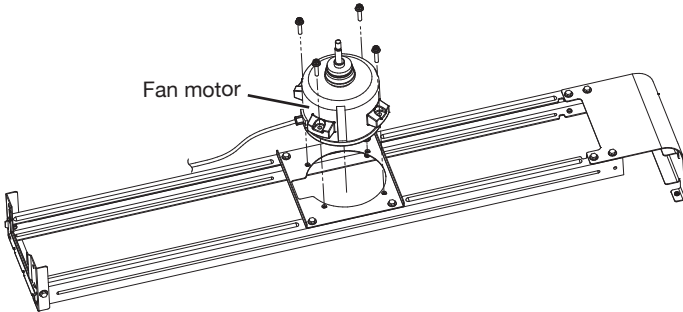
Step	Procedure	Points
2	Remove the nut and remove the fan. 	■ Nut size: M8
3	Remove 2 screws and remove the fan motor stand. 	
4	Remove 4 screws and remove the fan motor. 	■ The screws for fan motor are 3 class hexagon head tapping screws. (M5 × 25)

# REMOVAL & REASSEMBLY PROCEDURE

3.5 - 5.0 ton models HP and 3.0 - 4.0 ton HP Enhanced Capacity and 3.0 - 4.0 ton AC High Efficiency models only

## 3. Wiring (for HP models and 3.0 - 4.0 ton AC High Efficiency models)

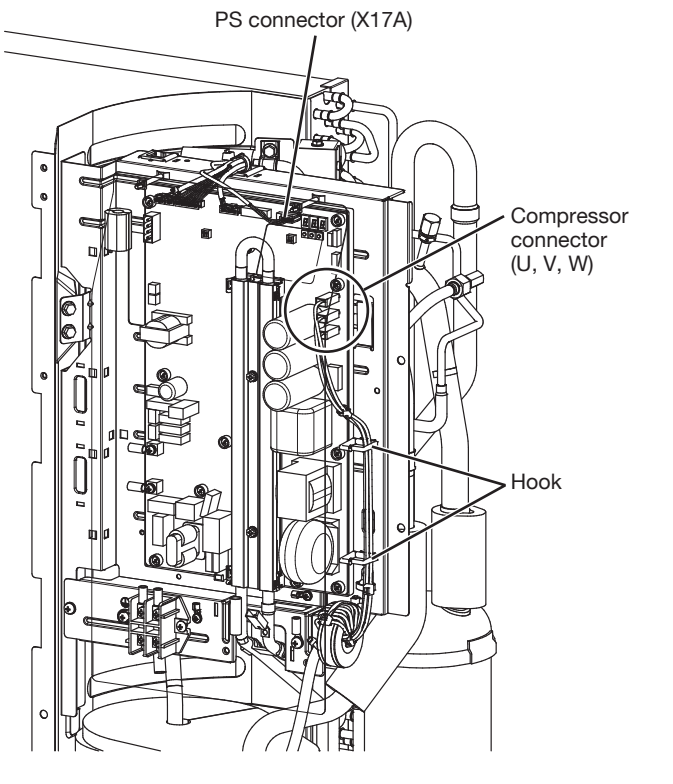
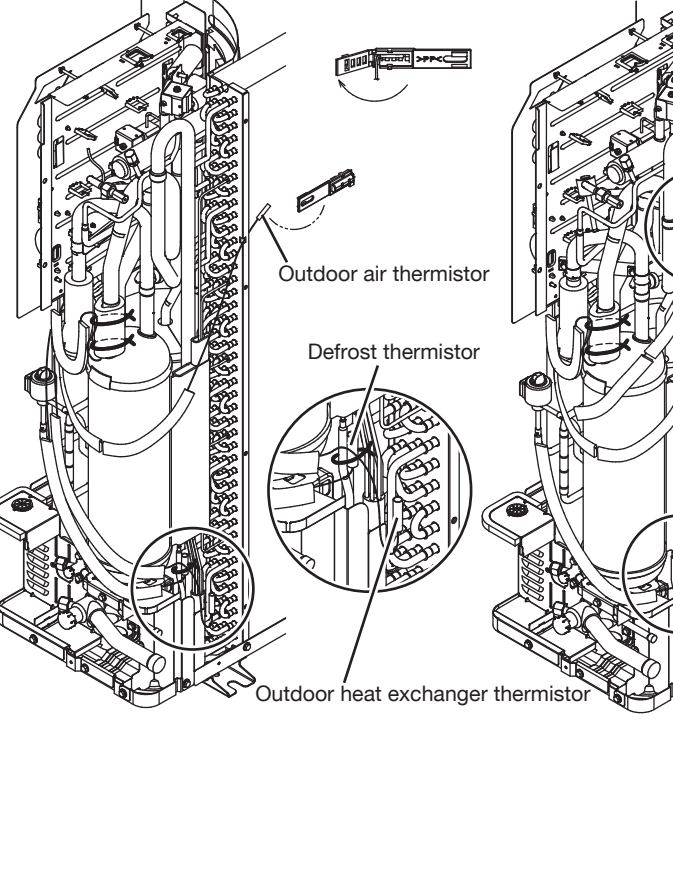
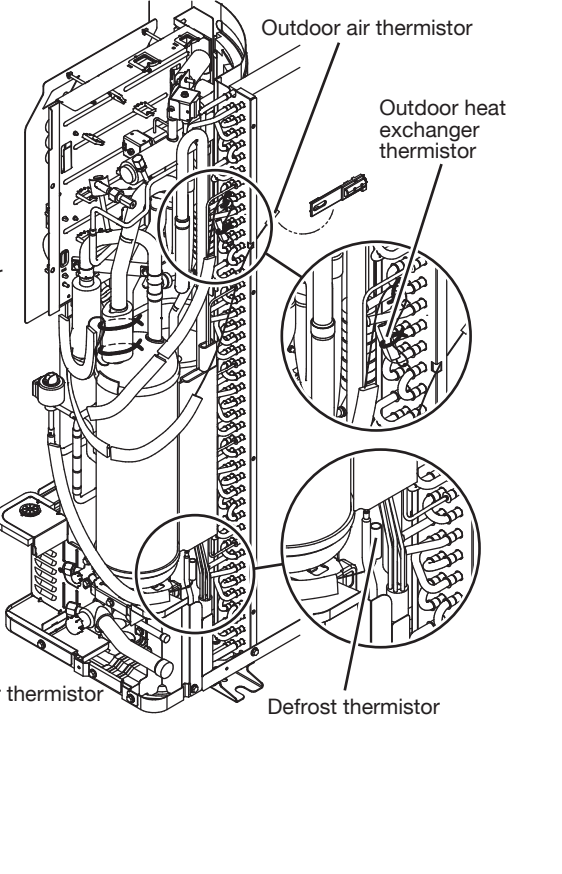
Step	Procedure	Points
<p>1 Disconnect the PS connector.</p> <p>2 Disconnect the compressor connectors and release the lead wires from the hooks.</p>	 <p>PS connector (X17A)</p> <p>Compressor connector (U, V, W)</p> <p>Hook</p>	
<p>3 Remove the outdoor air thermistor and outdoor heat exchanger thermistor.</p> <p>Remove the defrost thermistor.</p>	<p>■ <b>3.5/4.0 ton models and 3.0 ton Enhanced Capacity/High Efficiency models</b></p>  <p>Outdoor air thermistor</p> <p>Defrost thermistor</p> <p>Outdoor heat exchanger thermistor</p>	<p>■ <b>5.0 ton models and 3.5 - 4.0 ton Enhanced Capacity and 4.0 ton High Efficiency models</b></p>  <p>Outdoor air thermistor</p> <p>Outdoor heat exchanger thermistor</p> <p>Defrost thermistor</p>

# REMOVAL & REASSEMBLY PROCEDURE

3.5 - 5.0 ton models HP and 3.0 - 4.0 ton HP Enhanced Capacity and 3.0 - 4.0 ton AC High Efficiency models only

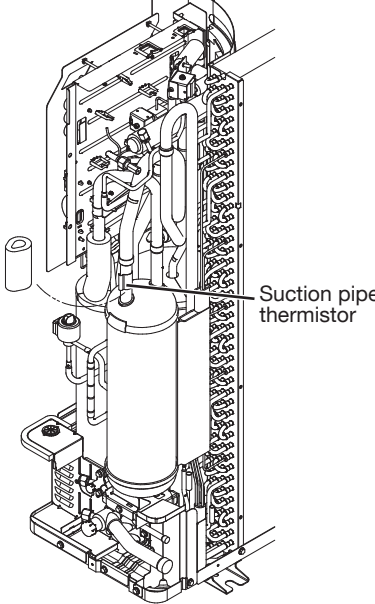
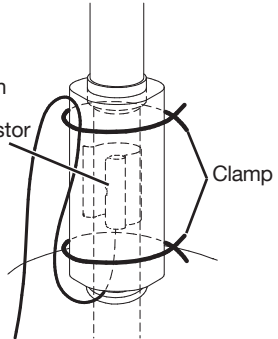
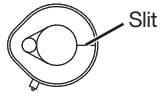
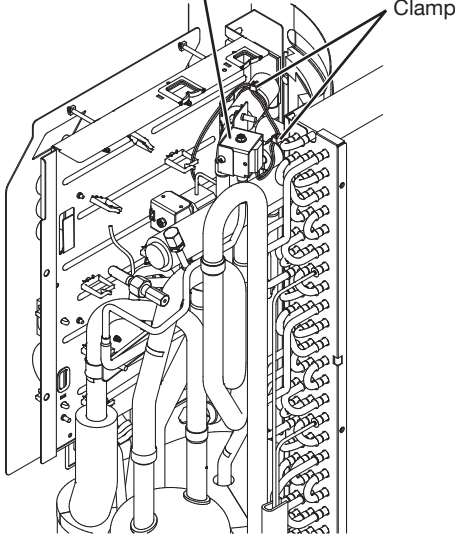
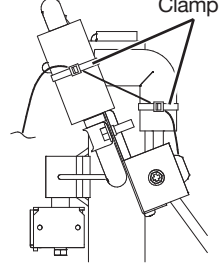
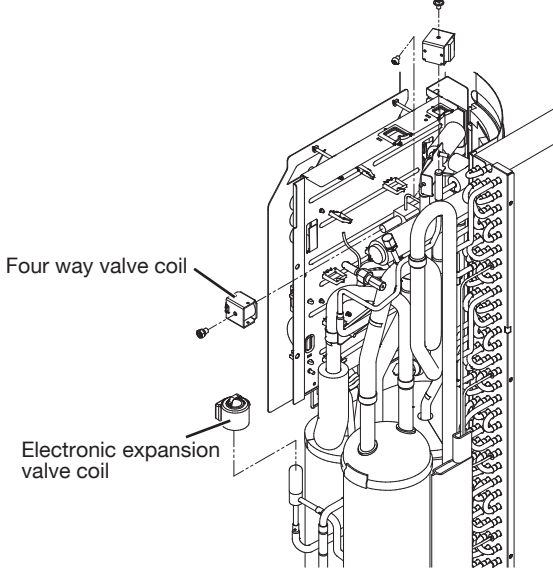
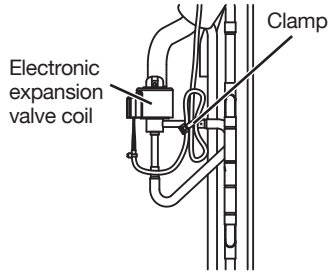
Step	Procedure	Points
4	<p>Remove the insulation tube and the suction pipe thermistor.</p>  <p>Suction pipe thermistor</p>	<ul style="list-style-type: none"> <li>■ Cut the 2 clamps and remove the insulation tube.</li> </ul>  <p>Suction pipe thermistor</p> <p>Clamp</p> <ul style="list-style-type: none"> <li>■ When reassembling, the slit of the insulation tube must be positioned opposite to the suction pipe thermistor.</li> </ul>  <p>Slit</p>
5	<p>Cut the 2 clamps of the solenoid valve coil lead wire.</p>  <p>Solenoid valve coil</p> <p>Clamp</p>	<ul style="list-style-type: none"> <li>■ Top view</li> </ul>  <p>Clamp</p>
6	<p>Remove 2 screws and remove the solenoid valve coil.</p> <p>Remove 1 screw and remove the four way valve coil.</p> <p>Cut the clamp and pull out the electronic expansion valve coil.</p>  <p>Four way valve coil</p> <p>Electronic expansion valve coil</p>	<ul style="list-style-type: none"> <li>■ Solenoid valve coil Tightening torque: 1.47-1.96 N·m (1.08-1.45 lb·ft) (M4 × 6)</li> <li>■ Four way valve coil Tightening torque: 3.2±0.8 N·m (2.36±0.59 lb·ft) (M5 × 6.5)</li> </ul>  <p>Clamp</p> <p>Electronic expansion valve coil</p>

# REMOVAL & REASSEMBLY PROCEDURE

3.5 - 5.0 ton models HP and 3.0 - 4.0 ton HP Enhanced Capacity and 3.0 - 4.0 ton AC High Efficiency models only

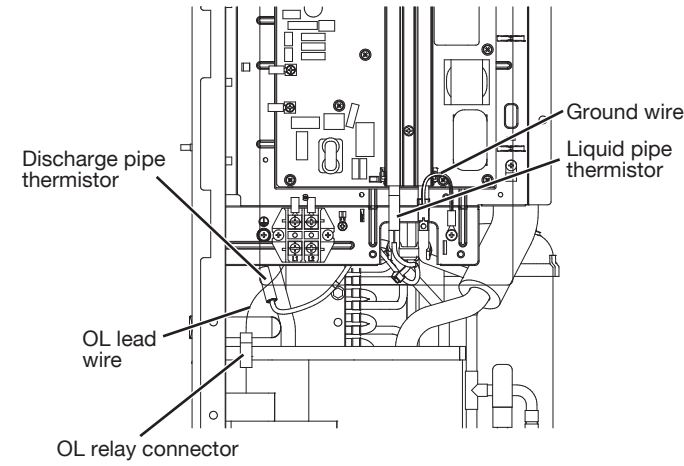
Step	Procedure	Points
7	<p>Remove the discharge pipe thermistor, liquid pipe thermistor and ground wire.</p> <p>Detach the OL (overload protector) relay connector.</p> 	

# REMOVAL & REASSEMBLY PROCEDURE

3.5 to 5.0 ton  
AC only

## 4. Wiring (for AC models)

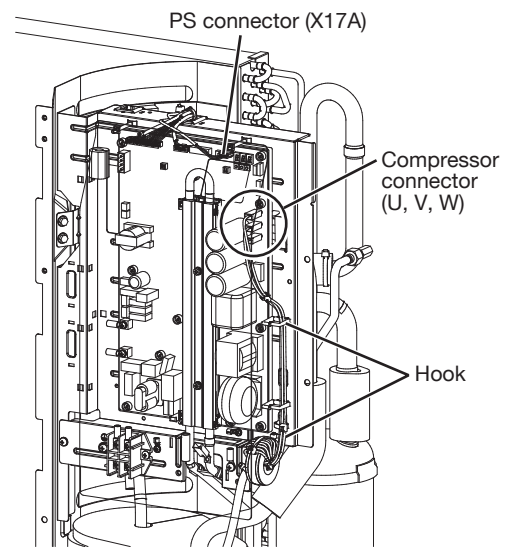
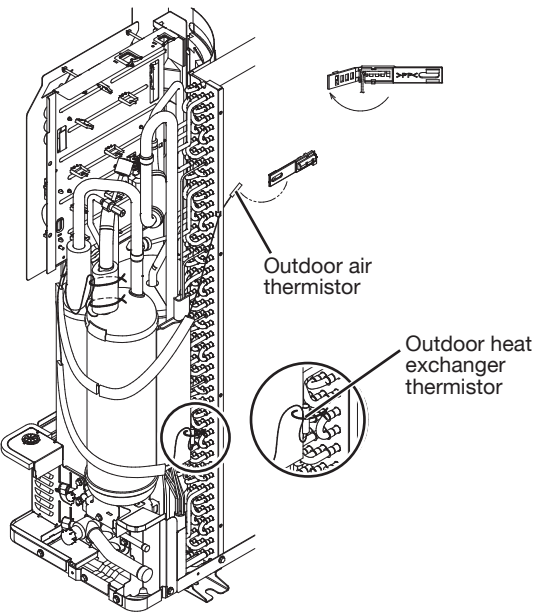
Step	Procedure	Points
<p>1 Disconnect the PS connector.</p> <p>2 Disconnect the compressor connectors and release the lead wires from the hooks.</p>	 <p>PS connector (X17A)</p> <p>Compressor connector (U, V, W)</p> <p>Hook</p>	
<p>3 Remove the outdoor air thermistor and outdoor heat exchanger thermistor.</p>	 <p>Outdoor air thermistor</p> <p>Outdoor heat exchanger thermistor</p>	<p>■ The illustration is for 5.0 ton model as representative.</p>

# REMOVAL & REASSEMBLY PROCEDURE

3.5 to 5.0 ton  
AC only

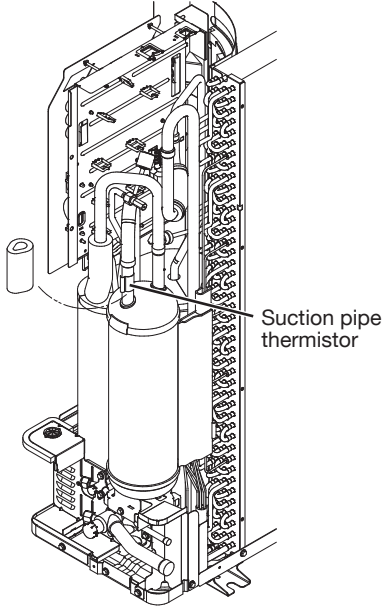
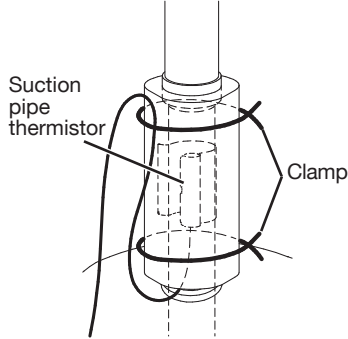
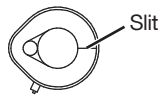
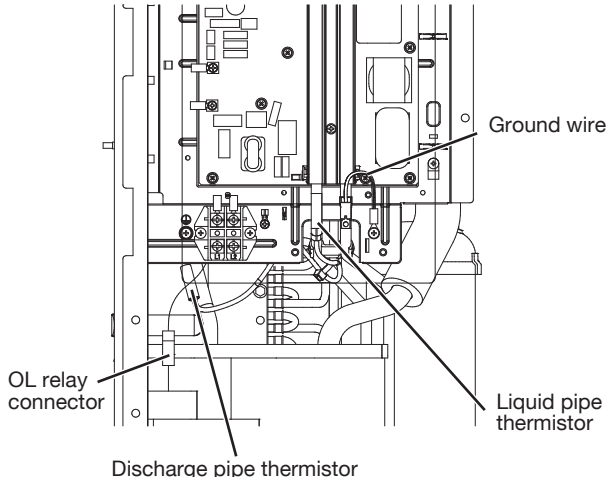
Step	Procedure	Points
4	<p>Remove the insulation tube and the suction pipe thermistor.</p>  <p>Suction pipe thermistor</p>	<ul style="list-style-type: none"> <li>■ Cut the 2 clamps and remove the insulation tube.</li> </ul>  <p>Suction pipe thermistor</p> <p>Clamp</p> <ul style="list-style-type: none"> <li>■ When reassembling, the slit of the insulation tube must be positioned opposite to the suction pipe thermistor.</li> </ul>  <p>Slit</p>
5	<p>Remove the discharge pipe thermistor, liquid pipe thermistor and ground wire.</p> <p>Detach the OL (overload protector) relay connector.</p>  <p>Ground wire</p> <p>OL relay connector</p> <p>Discharge pipe thermistor</p> <p>Liquid pipe thermistor</p>	

# REMOVAL & REASSEMBLY PROCEDURE

3.5 - 5.0 ton models HP & AC and 3.0 - 4.0 ton HP Enhanced Capacity and 3.0 - 4.0 ton AC High Efficiency models

## 5. Electrical box and PCB

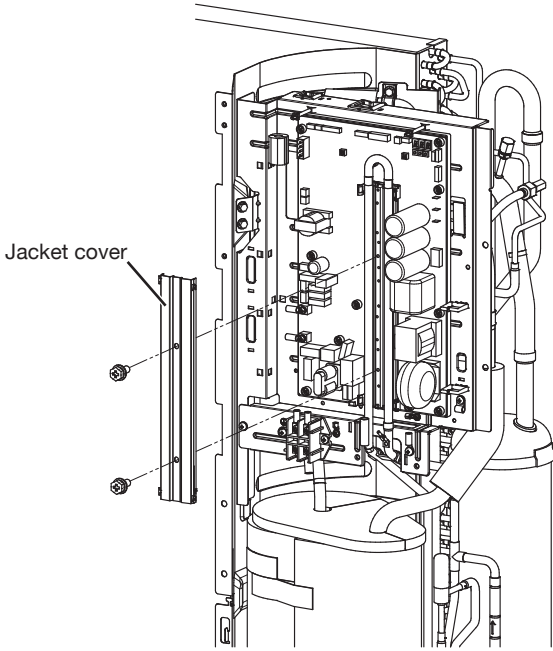
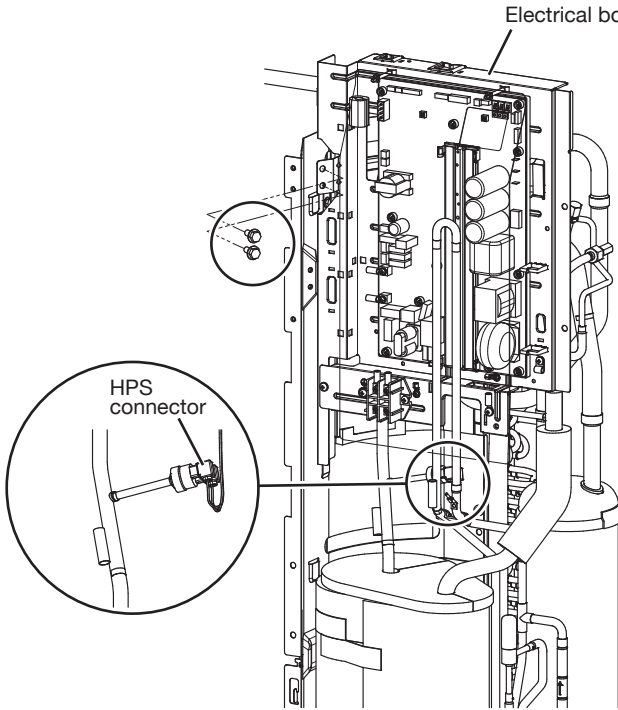
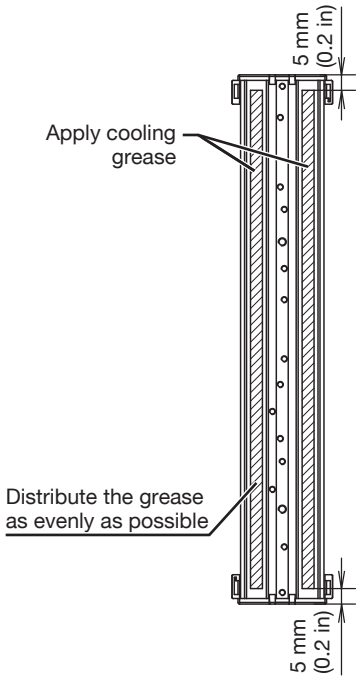
Step	Procedure	Procedure	Points
1	Remove 2 screws and remove the refrigerant cooling pipe jacket cover.		<ul style="list-style-type: none"> <li>■ The refrigerant cooling pipe screws are different from the remaining screws. Do not mix the screws. (M4 × 10)</li> <li>■ Tightening torque: 1.59±0.2 N·m (1.17±0.15 lb·ft) Tighten with a driver until the position where a tightening torque increases suddenly. Then extra-tighten by 30° to 40°.</li> <li>■ Remove the grease and apply new grease as indicated. Grease material: Shin Etsu G-776</li> </ul> <div style="border: 1px solid black; padding: 5px; margin-top: 10px;"> <ul style="list-style-type: none"> <li>- Coating range (▨)</li> <li>- Coat within limits of ±3 mm (0.12 in) from the center of the gutter.</li> <li>- The width of the grease is 2 mm (0.08 in) or more.</li> <li>- Applied amount of grease on each side: 2.1 (+0.5, 0) g (0.074(+0.018, 0) oz)</li> </ul> </div>
2	Remove 2 screws and remove the electrical box.  Detach the HPS connectors.		 <ul style="list-style-type: none"> <li>■ The screws marked with a circle are 3 class hexagon head tapping screws. Use the same screws when reassembling.</li> </ul>

# REMOVAL & REASSEMBLY PROCEDURE

3.5 - 5.0 ton models HP & AC and 3.0 - 4.0 ton HP Enhanced Capacity and 3.0 - 4.0 ton AC High Efficiency models

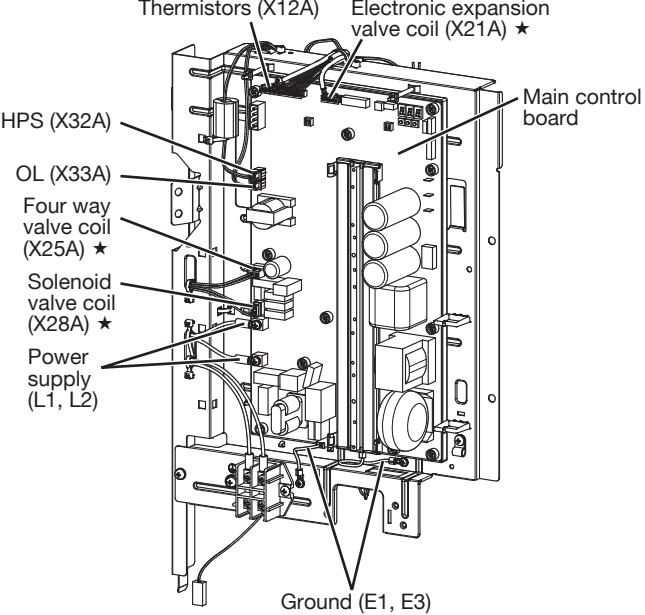
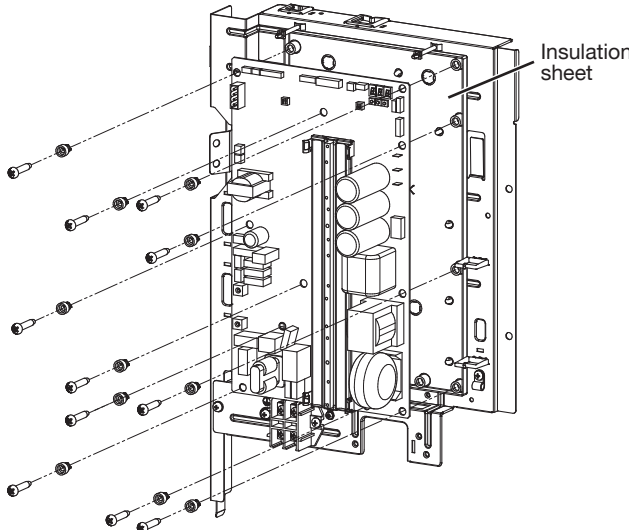
Step		Procedure	Points
3	Disconnect all the connectors on the main control board.	<p>Thermistors (X12A)    Electronic expansion valve coil (X21A) ★</p>  <p>HPS (X32A)</p> <p>OL (X33A)</p> <p>Four way valve coil (X25A) ★</p> <p>Solenoid valve coil (X28A) ★</p> <p>Power supply (L1, L2)</p> <p>Main control board</p> <p>Ground (E1, E3)</p>	★ HP models only
4	Remove 11 screws and remove the main control board and insulation sheet.	 <p>Insulation sheet</p>	

# REMOVAL & REASSEMBLY PROCEDURE

3.5 - 5.0 ton models HP and 3.0 - 4.0 ton HP Enhanced Capacity and 3.0 - 4.0 ton AC High Efficiency models only

## 6. Sound blankets and Compressor (for HP models and 3.0 - 4.0 ton AC High Efficiency models)

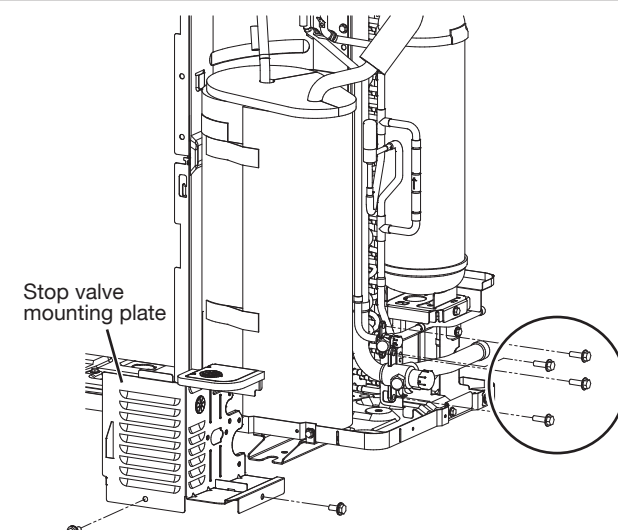
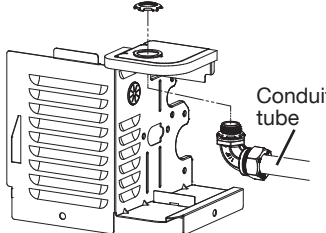
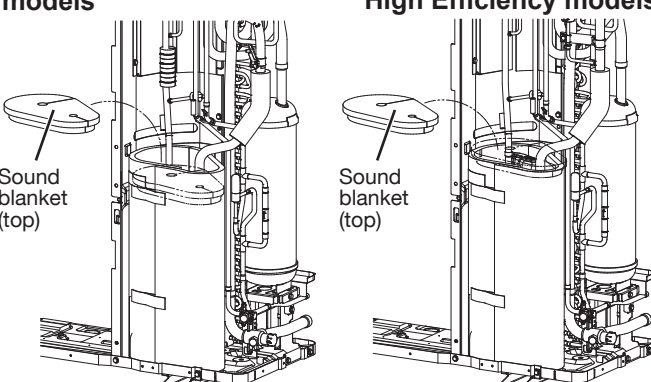
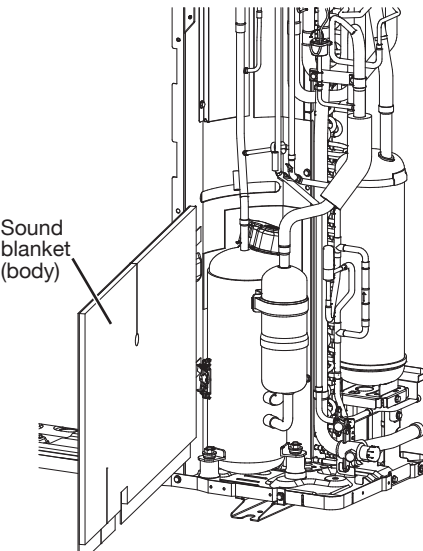
Step	Procedure	Points	
1	Remove 6 screws and remove the stop valve mounting plate.		<ul style="list-style-type: none"> <li>■ The screws marked with a circle is 3 class hexagon head tapping screws. Use the same screws when reassembling. (M5 × 16)</li> <li>■ Remove the conduit tube from stop valve mounting plate if the conduit tube is connected.</li> </ul> 
2	Remove the sound blanket (top).	<ul style="list-style-type: none"> <li>■ <b>3.5/4.0 ton models and 3.0 ton Enhanced Capacity/High Efficiency models</b></li> <li>■ <b>5.0 ton models and 3.5 - 4.0 ton Enhanced Capacity and 4.0 ton High Efficiency models</b></li> </ul> 	
3	Remove the sound blanket (body).		

# REMOVAL & REASSEMBLY PROCEDURE

3.5 - 5.0 ton models HP and 3.0 - 4.0 ton HP Enhanced Capacity and 3.0 - 4.0 ton AC High Efficiency models only

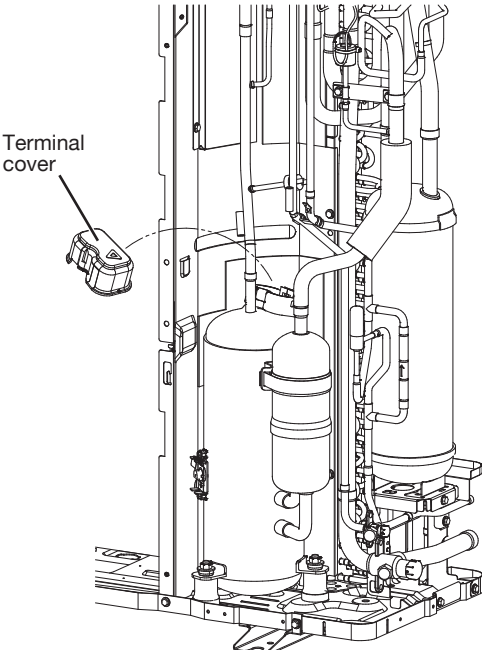
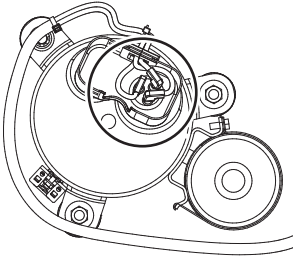
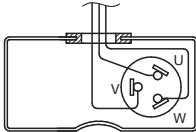
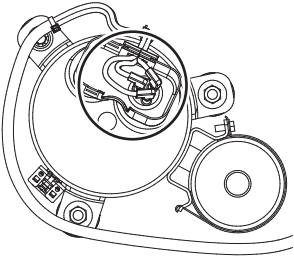
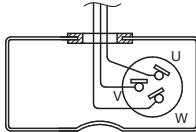
Step	Procedure	Points
4	Remove the terminal cover.	
5	Disconnect the compressor lead wire.	<div style="display: flex; justify-content: space-between;"> <div style="width: 45%;"> <p>■ <b>3.5/4.0 ton models and 3.0 ton Enhanced Capacity/High Efficiency models</b></p>   </div> <div style="width: 45%;"> <p>■ <b>5.0 ton models and 3.5 - 4.0 ton Enhanced Capacity and 4.0 ton High Efficiency models</b></p>   </div> </div> <p style="text-align: right; margin-top: 10px;">         U: Red          V: Yellow          W: Blue     </p>

# REMOVAL & REASSEMBLY PROCEDURE

3.5 - 5.0 ton models HP and 3.0 - 4.0 ton HP Enhanced Capacity and 3.0 - 4.0 ton AC High Efficiency models only

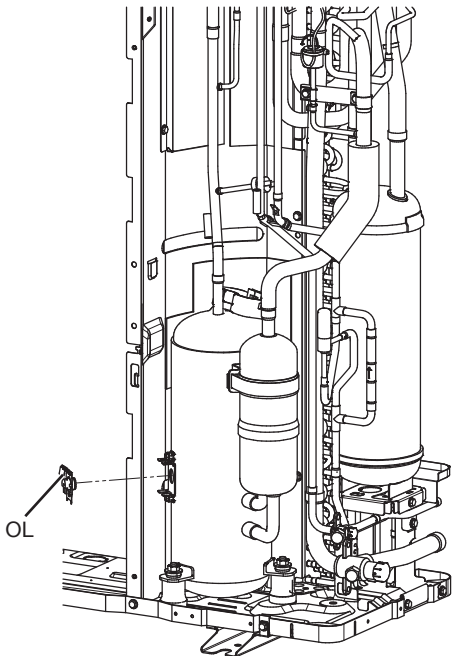
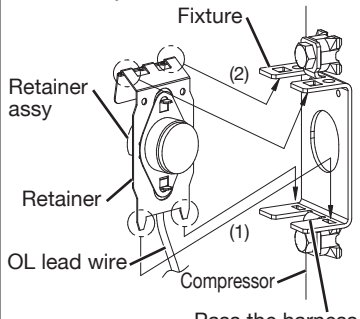
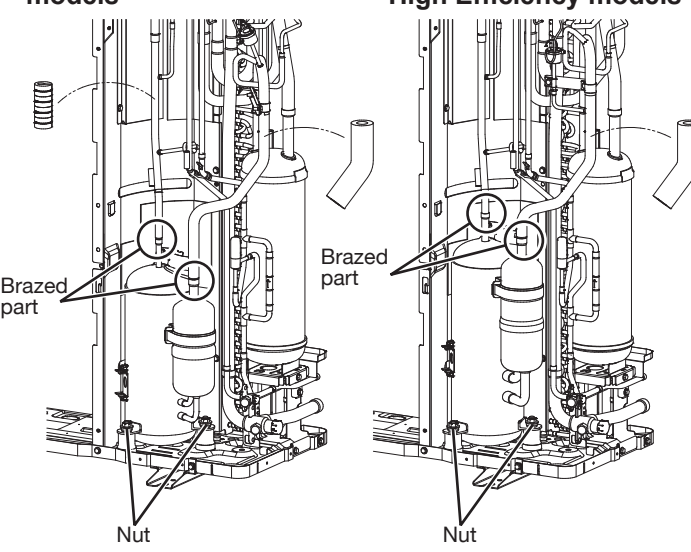
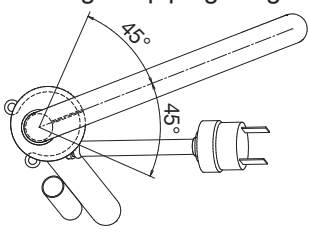
Step	Procedure	Points	
6	Remove the OL.	 <p>OL</p>	<ul style="list-style-type: none"> <li>When reassembling, attach the OL as shown below.                     <ol style="list-style-type: none"> <li>Insert lower hooks of retainer into the square holes of fixture.</li> <li>Push upper hooks of retainer until they hook in the square holes of fixture.</li> </ol> </li> </ul> 
7	<p>Heat up the brazed parts of compressor piping and disconnect them.</p> <p>Remove the 2 nuts that secure the compressor.</p>	<ul style="list-style-type: none"> <li><b>3.5/4.0 ton models and 3.0 ton Enhanced Capacity/High Efficiency models</b></li> <li><b>5.0 ton models and 3.5 - 4.0 ton Enhanced Capacity and 4.0 ton High Efficiency models</b></li> </ul> 	<ul style="list-style-type: none"> <li>Before working, be sure to remove any putties, the terminal cover, and other plastic pieces that may burn. Also, provide a protective sheet or a steel plate so that the brazing flame cannot influence peripheries.</li> <li>Slit range of piping weight.                      </li> </ul>

# REMOVAL & REASSEMBLY PROCEDURE

3.5 to 5.0 ton  
AC only

## 7. Sound blankets and Compressor (for AC models)

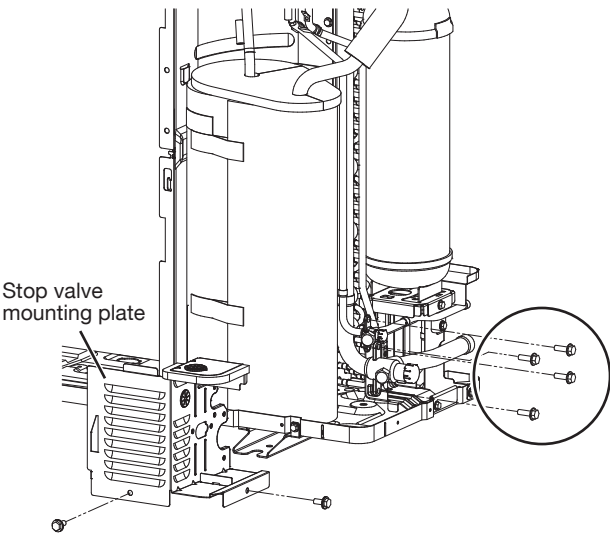
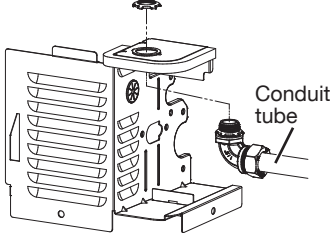
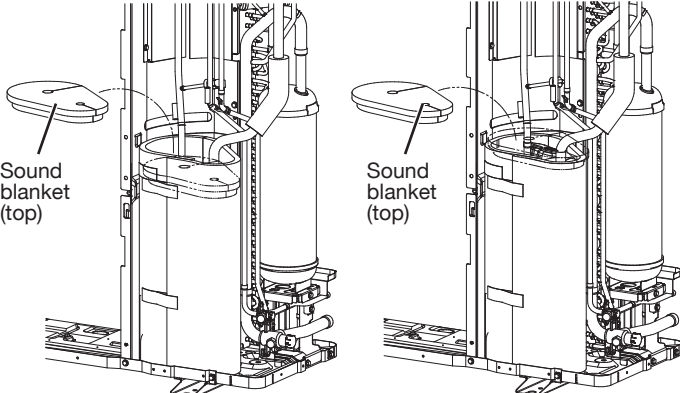
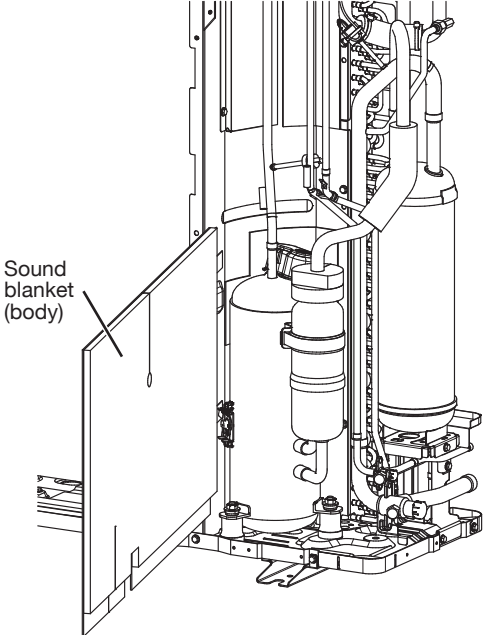
Step	Procedure	Procedure	Points
1	Remove 6 screws and remove the stop valve mounting plate.	 <p>Stop valve mounting plate</p>	<ul style="list-style-type: none"> <li>■ The screws marked with a circle is 3 class hexagon head tapping screws. Use the same screws when reassembling. (M5 × 16)</li> <li>■ Remove the conduit tube from stop valve mounting plate if the conduit tube is connected.</li> </ul>  <p>Conduit tube</p>
2	Remove the sound blanket (top).	<p>■ 3.5/4.0 ton</p> <p>■ 5.0 ton</p>  <p>Sound blanket (top)</p> <p>Sound blanket (top)</p>	
3	Remove the sound blanket (body).	 <p>Sound blanket (body)</p>	

# REMOVAL & REASSEMBLY PROCEDURE

3.5 to 5.0 ton  
AC only

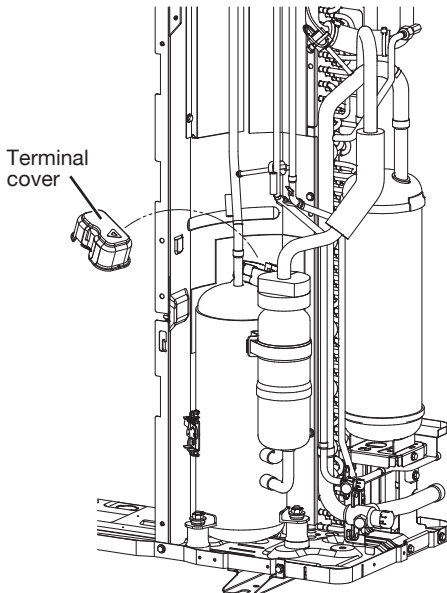
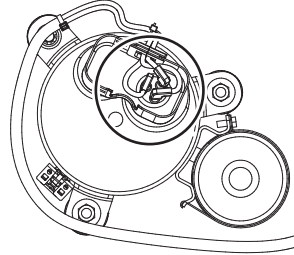
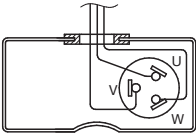
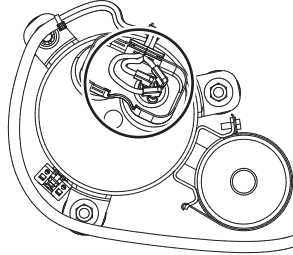
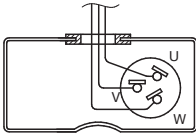
Step	Procedure	Points
4	<p>Remove the terminal cover.</p> 	<ul style="list-style-type: none"> <li>■ The illustration is for 5.0 ton model as representative.</li> </ul>
5	<p>Disconnect the compressor lead wire.</p> <div style="display: flex; justify-content: space-around;"> <div style="text-align: center;"> <p>■ 3.5/4.0 ton</p>   </div> <div style="text-align: center;"> <p>■ 5.0 ton</p>   </div> </div> <p style="text-align: right; margin-top: 10px;">             U: Red              V: Yellow              W: Blue         </p>	<ul style="list-style-type: none"> <li>■ The wiring is different depending on the model. When reassembling, be sure to connect the lead wires as shown in the left.</li> </ul>

# REMOVAL & REASSEMBLY PROCEDURE

3.5 to 5.0 ton  
AC only

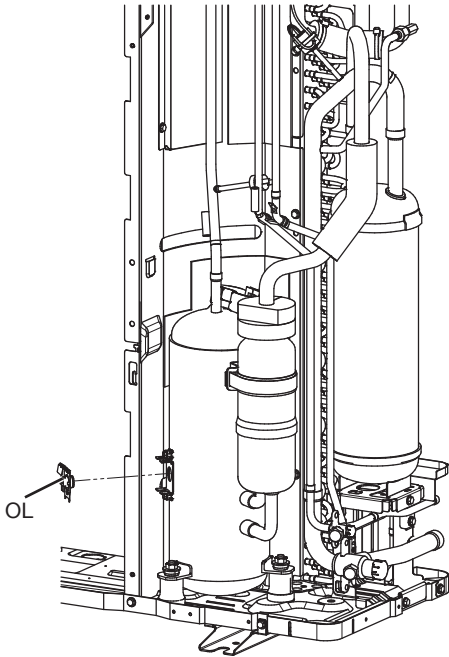
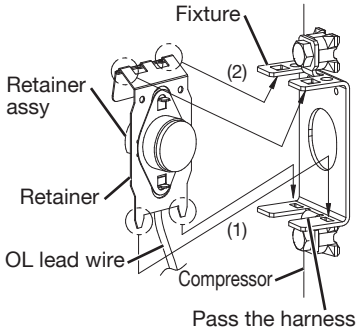
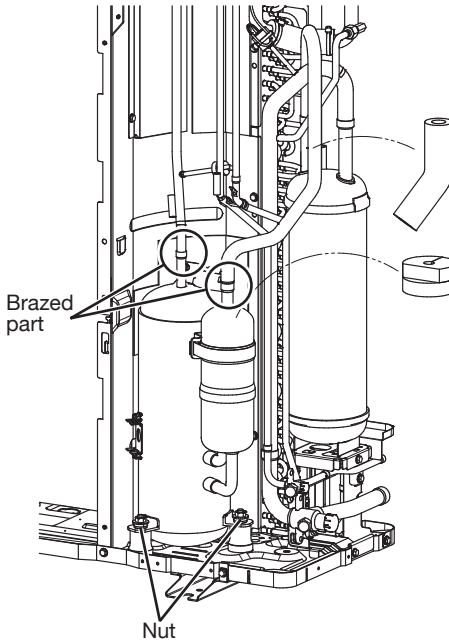
Step	Procedure	Procedure	Points
6	Remove the OL.		<ul style="list-style-type: none"> <li>■ When reassembling, attach the OL as shown below.                             <ol style="list-style-type: none"> <li>(1) Insert lower hooks of retainer into the square holes of fixture.</li> <li>(2) Push upper hooks of retainer until they hook in the square holes of fixture.</li> </ol> </li> </ul>  <p>Pass the harness</p>
7	<p>Heat up the brazed parts of compressor piping and disconnect them.</p> <p>Remove the 2 nuts that secure the compressor.</p>		<ul style="list-style-type: none"> <li>■ Before working, be sure to remove any putties, the terminal cover, and other plastic pieces that may burn. Also, provide a protective sheet or a steel plate so that the brazing flame cannot influence peripheries.</li> </ul>

# REMOVAL & REASSEMBLY PROCEDURE

3.5 - 5.0 ton models HP and 3.0 - 4.0 ton HP Enhanced Capacity and 3.0 - 4.0 ton AC High Efficiency models only

## 8. Heat exchanger (for HP models and 3.0 - 4.0 ton AC High Efficiency models)

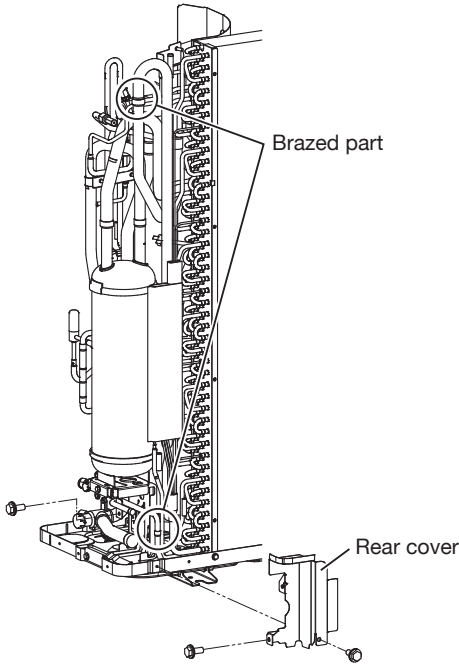
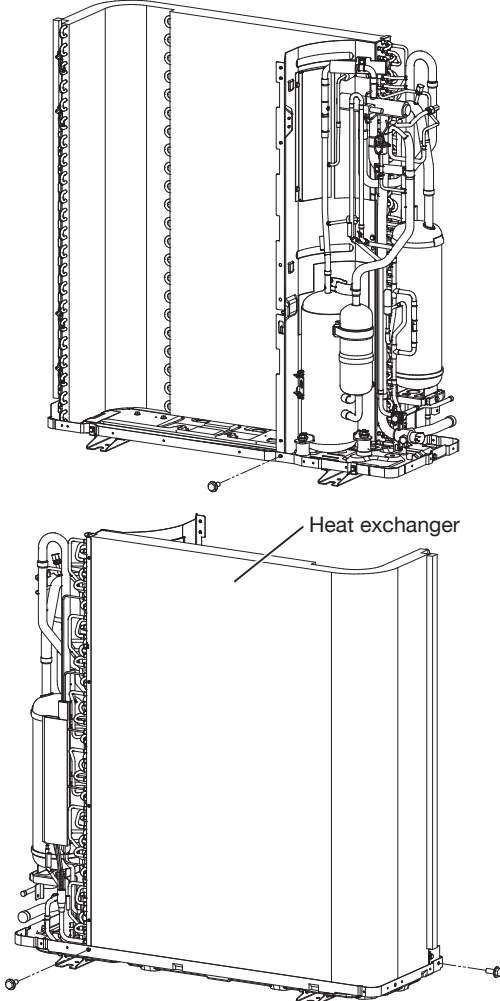
Step	Procedure	Points
1	<p>Remove 3 screws and remove the rear cover.</p> <p>Heat up the brazed parts of heat exchanger and disconnect them.</p> 	<ul style="list-style-type: none"> <li>Before working, be sure to remove any putties, the terminal cover, and other plastic pieces that may burn. Also, provide a protective sheet or a steel plate so that the brazing flame cannot influence peripheries.</li> </ul>
2	<p>Remove 3 screws and remove the heat exchanger.</p> 	<ul style="list-style-type: none"> <li>The illustration is for 5.0 ton model as representative.</li> </ul>



# REMOVAL & REASSEMBLY PROCEDURE

3.5 to 5.0 ton  
AC only

## 9. Heat exchanger (for AC models)

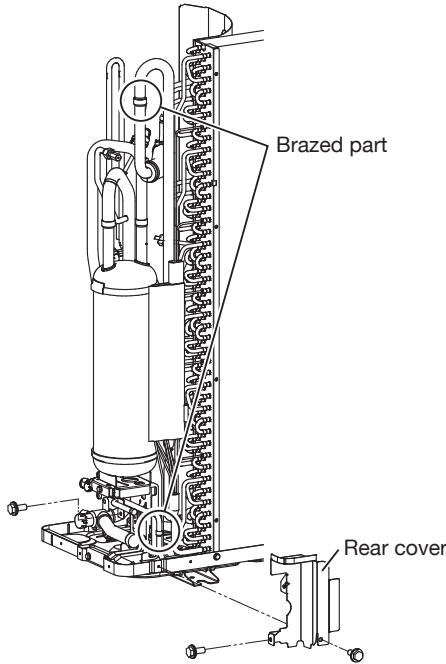
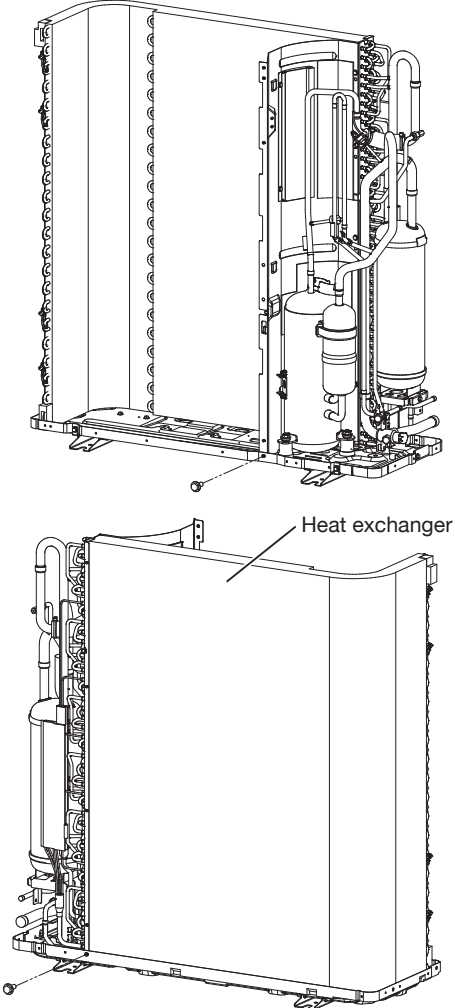
Step	Procedure	Procedure	Points
1	Remove 3 screws and remove the rear cover.  Heat up the brazed parts of heat exchanger and disconnect them.		<ul style="list-style-type: none"><li>■ Before working, be sure to remove any putties, the terminal cover, and other plastic pieces that may burn. Also, provide a protective sheet or a steel plate so that the brazing flame cannot influence peripheries.</li></ul>
2	Remove 2 screws and remove the heat exchanger.		<ul style="list-style-type: none"><li>■ The illustration is for 5.0 ton model as representative.</li></ul>

# REMOVAL & REASSEMBLY PROCEDURE

3.5 to 5.0 ton  
AC only

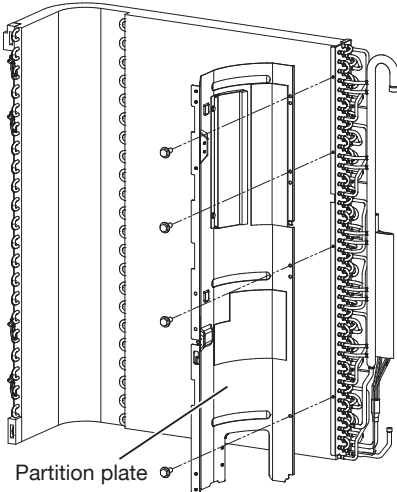
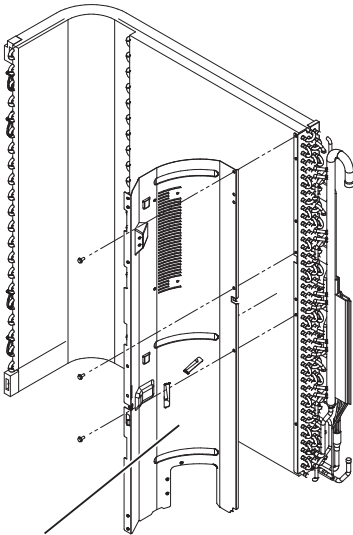
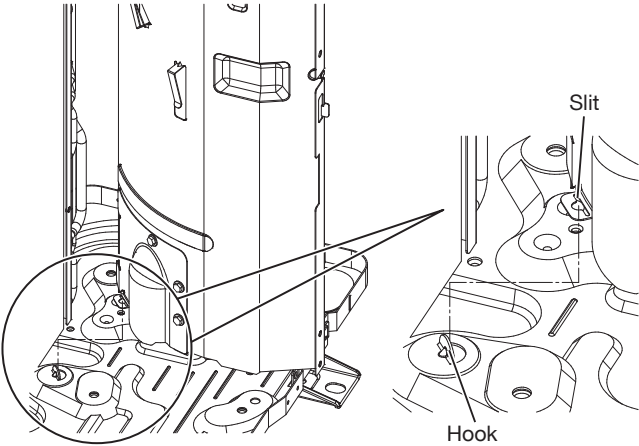
Step	Procedure	Points
3	<p data-bbox="185 165 444 293">For 4 screws model, remove 4 screws and remove the partition plate.</p>  <p data-bbox="634 634 769 661">Partition plate</p> <p data-bbox="185 791 444 919">For 3 screws model, remove 3 screws and remove the partition plate.</p>  <p data-bbox="634 1327 769 1355">Partition plate</p>  <p data-bbox="1068 1519 1105 1547">Slit</p> <p data-bbox="948 1847 1002 1874">Hook</p>	<p data-bbox="1182 1400 1549 1527">■ When reassembling, insert the hook of the bottom frame into the slit of the partition plate.</p>

# D-CHECKER ADDENDUM

- The **Daikin D-Checker software** is used for **monitoring** or **recording** operation data of inverter using a connection cable exclusive to D-Checker. Please use correctly by carefully reading the instruction manual.
- This software can monitor inverter sensor data (temperature, pressure) and actuator status (compressor, solenoid, etc.). Data/status items that are supported by this software differ from model to model.
- D-Checker gathers operating data from an inverter through a **PCB connector** on the outdoor unit.
- Data monitoring/recording of **multiple** outdoor units is **not supported**.
- Note: The values shown in this addendum are intended for instruction purposes only. Please refer to product specific literature (IO Manual) for appropriate operation ranges for current unit.

## Installing D-Checker

- 1 Copy the latest version of D-checker software to any folder on PC.
- 2 Execute software
- 3 Confirm you have latest version of software (Contact [TechSupport@daikincomfort.com](mailto:TechSupport@daikincomfort.com) for latest version).
- 4 Click on Options (F6)

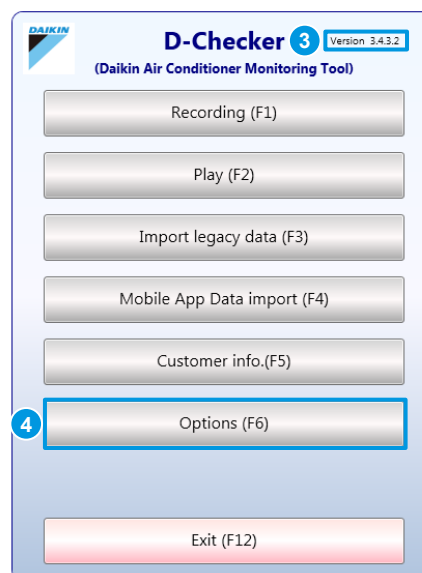

- 5 Select COM Port
- 6 Select unit of measurement
- 7 Select Sampling Rate (Recommend 5 sec)
- 8 Enter Service Office (Your Name/Dept)
- 9 Enter Responsible Person (Your Name)
- 10 Press OK when Finished

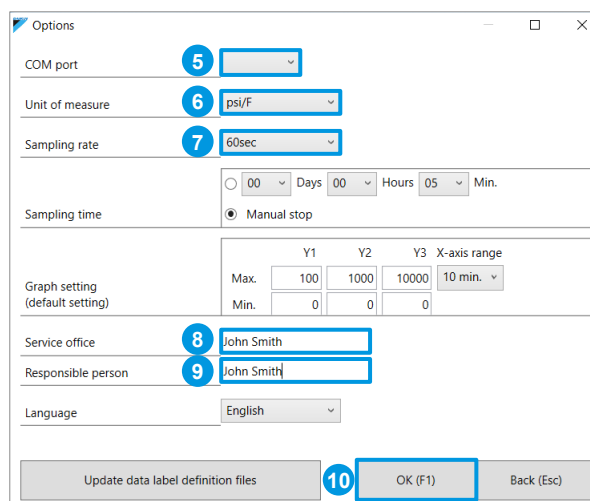

# D-CHECKER ADDENDUM

## D-Checker Cable Connects to Plug X41A on both Boards

- Small Chassis 1.5 - 3.0 ton models and 2.0 ton Enhanced Capacity/High Efficiency models
- Large Chassis 3.5 - 5.0 ton models and 3.0 - 4.0 ton Enhanced Capacity/High Efficiency models

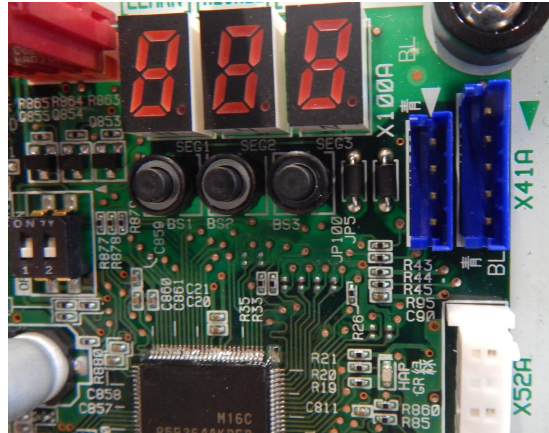
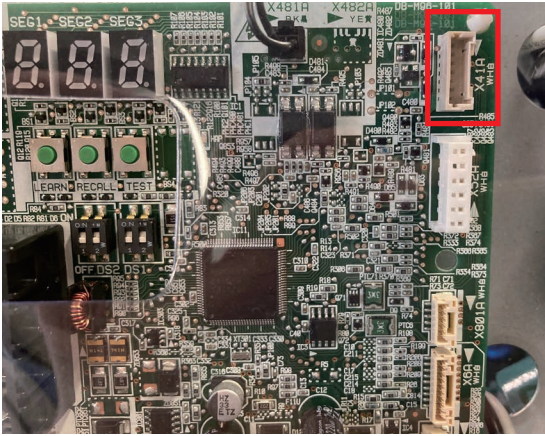

## COM Port Verification

- Open the device manager software in your laptop.
- Connect the USB plug of the D-Checker cable into your laptop, and the terminal plug end into **X41A** on the outdoor unit PCB.
- Within the device manager software, open the **hardware** selection.
- Once open you will see a list of the hardware items on your laptop.
- One of the items will be **COM Ports**.
- Open COM Ports and the COM Port your USB connector is using will be visible.

# D-CHECKER ADDENDUM

## View System Operation

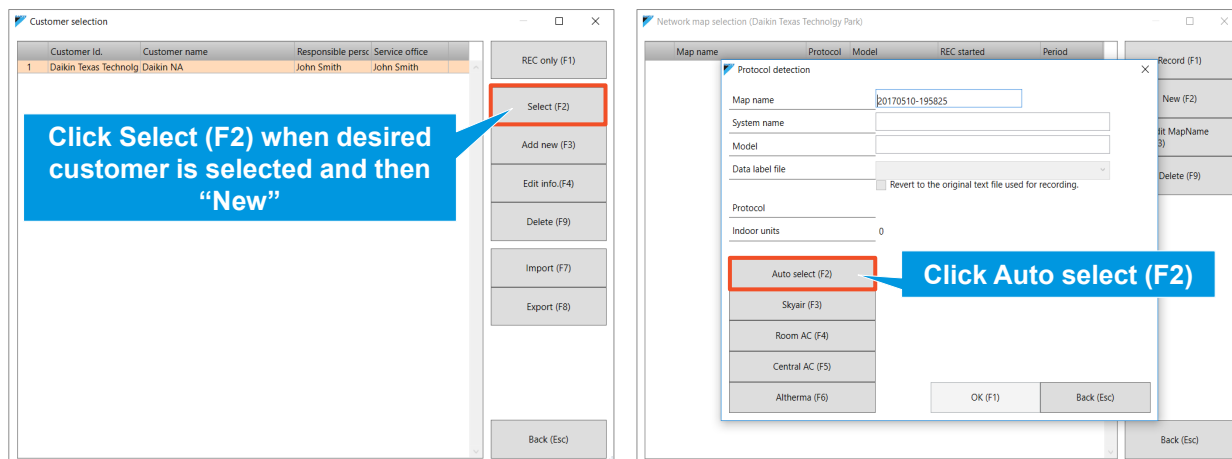
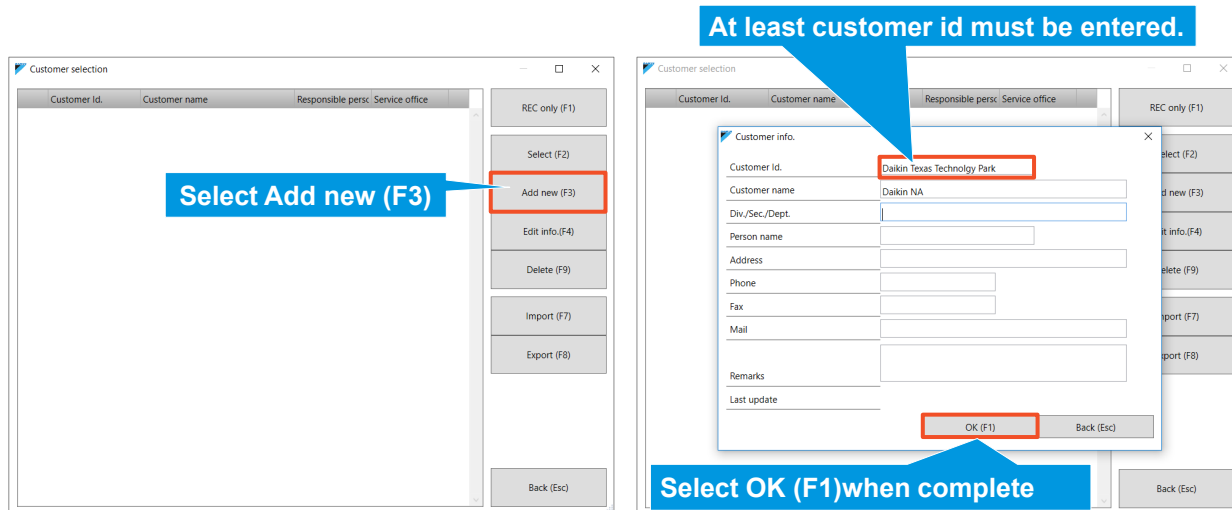
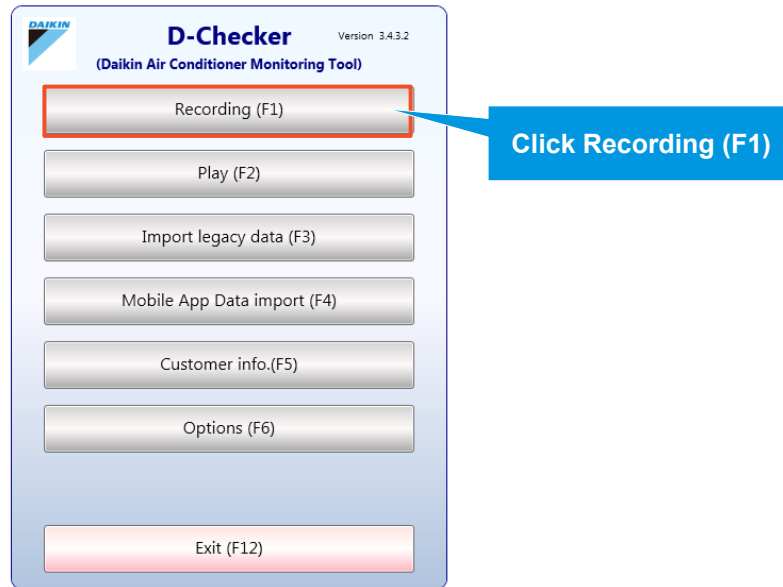

**Note: D-checker will Not communicate with a system in sleep mode or hibernate.**

# D-CHECKER ADDENDUM

Select correct COM port, then press OK (F1)

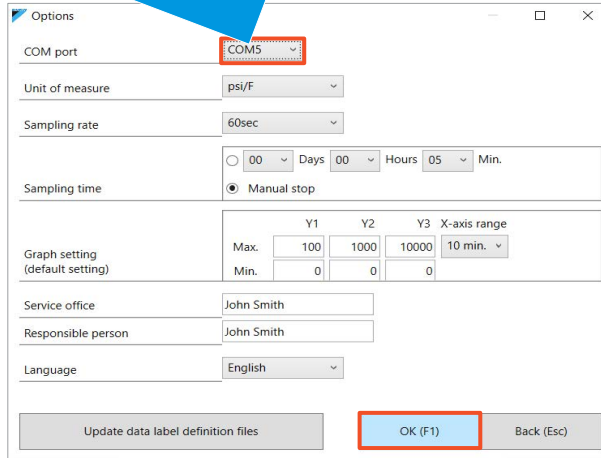
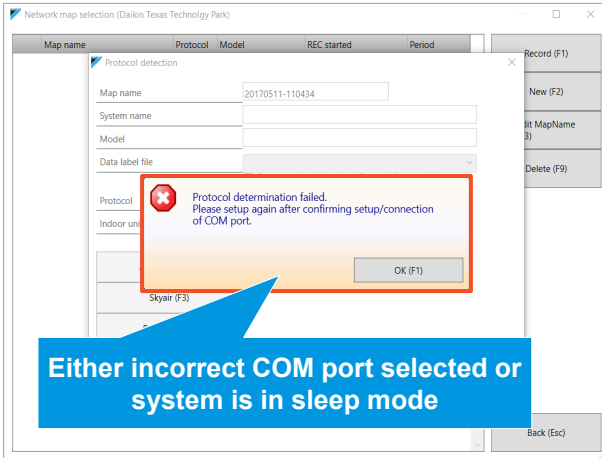

When detection method completes a system name will populate

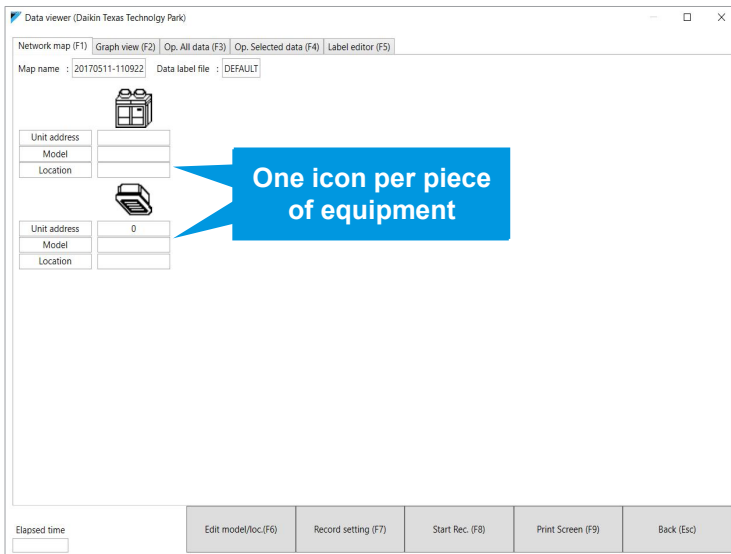
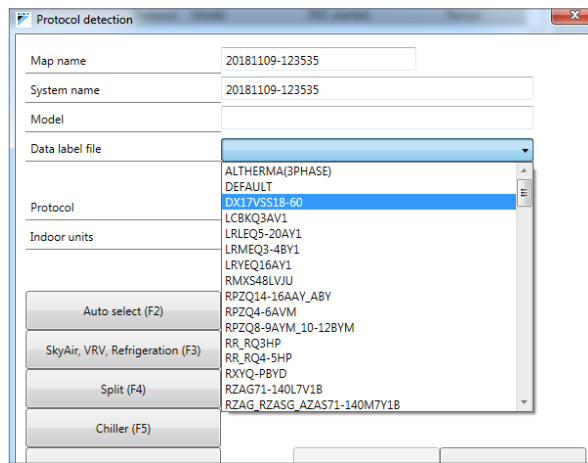
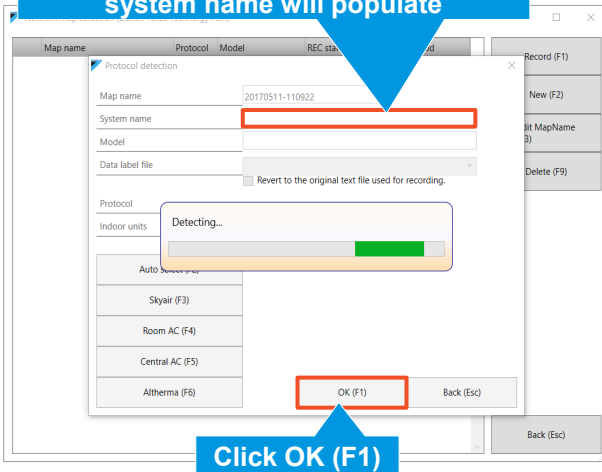

# D-CHECKER ADDENDUM

## Recording Operation Data

**Click OK (F1)**

**If Recording is required, click Start Rec. (F6)**

**Time recorded will populate**

**Select Graph View (F2)**

**Selected data points from Op. Selected data (F4)**

**3 Analog scales to choose from on Graph 100, 1000, 10000**

**Selected Binary data points**

**Reflects how selected data points are scaled**

**Select Op. All Data (F3)**

**Select Op. Selected Data (F4)**

**Left Click, then Right click to select desired data on graph view**

Data name	Value	Data name	Value
1	Operation Mode	Cooling	45
2	1 D Defrost Operation	OFF	46
3	1 A Outdoor Air Temp.	71.60 (F)	73
4	1 A Outdoor Heat Exchanger Tem	95.00 (F)	74
5	2 A Max Hz by Freeze Protection	62	75
6	2 A Max Hz by Peak Cut crnt(ips)	133.70 (F)	76
7	2 A Max Hz by Discharge Temp.	94.10 (F)	77
8	2 A Max Hz by Input Current crnt	3.75	78
9	2 A Maximum Comp. Frequency	62	79
10	2 A Minimum Comp. Frequency	0	80
11	2 A Comp. Stop Timer (sec)	0	81
12	2 A Outdoor Fan Delay Timer(sec)	60	82
13	3 A Port A EV (pls)	170	83
14	3 A Target Discharge Temp.	134.60 (F)	84
15	3 A Target Out Fan1 Frequency(ips)	860	85
16	3 A Target Out Fan2 Frequency(ips)	860	86
17	3 A Operation Current(A)	3.75	87
18	3 A Power Source Voltage(V)	209.3	88
19	3 A Discharge pipe temp.	135.50 (F)	89
20	3 A Fan Temp.	95.00 (F)	90
21	3 A Out Fan 1 Frequency(ips)	863	91
22	3 A Out Fan 2 Frequency(ips)	863	92
23	3 A Operation Current(A)	3.75	93
24	3 A Power Source Voltage(V)	209.3	94
25	3 A Discharge pipe temp.	135.50 (F)	95
26	3 A Fan Temp.	95.00 (F)	96
27	3 A Out Fan 1 Frequency(ips)	860	97
28	3 A Out Fan 2 Frequency(ips)	860	98
29	3 A Operation Current(A)	3.75	99
30	3 A Power Source Voltage(V)	209.3	100
31	3 A Discharge pipe temp.	135.50 (F)	101
32	3 A Fan Temp.	95.00 (F)	102
33	3 A Out Fan 1 Frequency(ips)	860	103
34	3 A Out Fan 2 Frequency(ips)	860	104
35	3 A Operation Current(A)	3.75	105
36	3 A Power Source Voltage(V)	209.3	106
37	3 A Discharge pipe temp.	135.50 (F)	107
38	3 A Fan Temp.	95.00 (F)	108
39	3 A Out Fan 1 Frequency(ips)	860	109
40	3 A Out Fan 2 Frequency(ips)	860	110
41	3 A Operation Current(A)	3.75	111
42	3 A Power Source Voltage(V)	209.3	112
43	3 A Discharge pipe temp.	135.50 (F)	113
44	3 A Fan Temp.	95.00 (F)	114
45	3 A Out Fan 1 Frequency(ips)	860	115
46	3 A Out Fan 2 Frequency(ips)	860	116
47	3 A Operation Current(A)	3.75	117
48	3 A Power Source Voltage(V)	209.3	118
49	3 A Discharge pipe temp.	135.50 (F)	119
50	3 A Fan Temp.	95.00 (F)	120
51	3 A Out Fan 1 Frequency(ips)	860	121
52	3 A Out Fan 2 Frequency(ips)	860	122
53	3 A Operation Current(A)	3.75	123
54	3 A Power Source Voltage(V)	209.3	124
55	3 A Discharge pipe temp.	135.50 (F)	125
56	3 A Fan Temp.	95.00 (F)	126
57	3 A Out Fan 1 Frequency(ips)	860	127
58	3 A Out Fan 2 Frequency(ips)	860	128
59	3 A Operation Current(A)	3.75	129
60	3 A Power Source Voltage(V)	209.3	130
61	3 A Discharge pipe temp.	135.50 (F)	131
62	3 A Fan Temp.	95.00 (F)	132
63	3 A Out Fan 1 Frequency(ips)	860	133
64	3 A Out Fan 2 Frequency(ips)	860	134
65	3 A Operation Current(A)	3.75	135
66	3 A Power Source Voltage(V)	209.3	136
67	3 A Discharge pipe temp.	135.50 (F)	137
68	3 A Fan Temp.	95.00 (F)	138
69	3 A Out Fan 1 Frequency(ips)	860	139
70	3 A Out Fan 2 Frequency(ips)	860	140
71	3 A Operation Current(A)	3.75	141
72	3 A Power Source Voltage(V)	209.3	142
73	3 A Discharge pipe temp.	135.50 (F)	143
74	3 A Fan Temp.	95.00 (F)	144
75	3 A Out Fan 1 Frequency(ips)	860	145
76	3 A Out Fan 2 Frequency(ips)	860	146
77	3 A Operation Current(A)	3.75	147
78	3 A Power Source Voltage(V)	209.3	148
79	3 A Discharge pipe temp.	135.50 (F)	149
80	3 A Fan Temp.	95.00 (F)	150
81	3 A Out Fan 1 Frequency(ips)	860	151
82	3 A Out Fan 2 Frequency(ips)	860	152
83	3 A Operation Current(A)	3.75	153
84	3 A Power Source Voltage(V)	209.3	154
85	3 A Discharge pipe temp.	135.50 (F)	155
86	3 A Fan Temp.	95.00 (F)	156
87	3 A Out Fan 1 Frequency(ips)	860	157
88	3 A Out Fan 2 Frequency(ips)	860	158
89	3 A Operation Current(A)	3.75	159
90	3 A Power Source Voltage(V)	209.3	160
91	3 A Discharge pipe temp.	135.50 (F)	161
92	3 A Fan Temp.	95.00 (F)	162
93	3 A Out Fan 1 Frequency(ips)	860	163
94	3 A Out Fan 2 Frequency(ips)	860	164
95	3 A Operation Current(A)	3.75	165
96	3 A Power Source Voltage(V)	209.3	166
97	3 A Discharge pipe temp.	135.50 (F)	167
98	3 A Fan Temp.	95.00 (F)	168
99	3 A Out Fan 1 Frequency(ips)	860	169
100	3 A Out Fan 2 Frequency(ips)	860	170
101	3 A Operation Current(A)	3.75	171
102	3 A Power Source Voltage(V)	209.3	172
103	3 A Discharge pipe temp.	135.50 (F)	173
104	3 A Fan Temp.	95.00 (F)	174
105	3 A Out Fan 1 Frequency(ips)	860	175
106	3 A Out Fan 2 Frequency(ips)	860	176
107	3 A Operation Current(A)	3.75	177
108	3 A Power Source Voltage(V)	209.3	178
109	3 A Discharge pipe temp.	135.50 (F)	179
110	3 A Fan Temp.	95.00 (F)	180
111	3 A Out Fan 1 Frequency(ips)	860	181
112	3 A Out Fan 2 Frequency(ips)	860	182
113	3 A Operation Current(A)	3.75	183
114	3 A Power Source Voltage(V)	209.3	184
115	3 A Discharge pipe temp.	135.50 (F)	185
116	3 A Fan Temp.	95.00 (F)	186
117	3 A Out Fan 1 Frequency(ips)	860	187
118	3 A Out Fan 2 Frequency(ips)	860	188
119	3 A Operation Current(A)	3.75	189
120	3 A Power Source Voltage(V)	209.3	190
121	3 A Discharge pipe temp.	135.50 (F)	191
122	3 A Fan Temp.	95.00 (F)	192
123	3 A Out Fan 1 Frequency(ips)	860	193
124	3 A Out Fan 2 Frequency(ips)	860	194
125	3 A Operation Current(A)	3.75	195
126	3 A Power Source Voltage(V)	209.3	196
127	3 A Discharge pipe temp.	135.50 (F)	197
128	3 A Fan Temp.	95.00 (F)	198
129	3 A Out Fan 1 Frequency(ips)	860	199
130	3 A Out Fan 2 Frequency(ips)	860	200
131	3 A Operation Current(A)	3.75	201
132	3 A Power Source Voltage(V)	209.3	202
133	3 A Discharge pipe temp.	135.50 (F)	203
134	3 A Fan Temp.	95.00 (F)	204
135	3 A Out Fan 1 Frequency(ips)	860	205
136	3 A Out Fan 2 Frequency(ips)	860	206
137	3 A Operation Current(A)	3.75	207
138	3 A Power Source Voltage(V)	209.3	208
139	3 A Discharge pipe temp.	135.50 (F)	209
140	3 A Fan Temp.	95.00 (F)	210
141	3 A Out Fan 1 Frequency(ips)	860	211
142	3 A Out Fan 2 Frequency(ips)	860	212
143	3 A Operation Current(A)	3.75	213
144	3 A Power Source Voltage(V)	209.3	214
145	3 A Discharge pipe temp.	135.50 (F)	215
146	3 A Fan Temp.	95.00 (F)	216
147	3 A Out Fan 1 Frequency(ips)	860	217
148	3 A Out Fan 2 Frequency(ips)	860	218
149	3 A Operation Current(A)	3.75	219
150	3 A Power Source Voltage(V)	209.3	220
151	3 A Discharge pipe temp.	135.50 (F)	221
152	3 A Fan Temp.	95.00 (F)	222
153	3 A Out Fan 1 Frequency(ips)	860	223
154	3 A Out Fan 2 Frequency(ips)	860	224
155	3 A Operation Current(A)	3.75	225
156	3 A Power Source Voltage(V)	209.3	226
157	3 A Discharge pipe temp.	135.50 (F)	227
158	3 A Fan Temp.	95.00 (F)	228
159	3 A Out Fan 1 Frequency(ips)	860	229
160	3 A Out Fan 2 Frequency(ips)	860	230
161	3 A Operation Current(A)	3.75	231
162	3 A Power Source Voltage(V)	209.3	232
163	3 A Discharge pipe temp.	135.50 (F)	233
164	3 A Fan Temp.	95.00 (F)	234
165	3 A Out Fan 1 Frequency(ips)	860	235
166	3 A Out Fan 2 Frequency(ips)	860	236
167	3 A Operation Current(A)	3.75	237
168	3 A Power Source Voltage(V)	209.3	238
169	3 A Discharge pipe temp.	135.50 (F)	239
170	3 A Fan Temp.	95.00 (F)	240
171	3 A Out Fan 1 Frequency(ips)	860	241
172	3 A Out Fan 2 Frequency(ips)	860	242
173	3 A Operation Current(A)	3.75	243
174	3 A Power Source Voltage(V)	209.3	244
175	3 A Discharge pipe temp.	135.50 (F)	245
176	3 A Fan Temp.	95.00 (F)	246
177	3 A Out Fan 1 Frequency(ips)	860	247
178	3 A Out Fan 2 Frequency(ips)	860	248
179	3 A Operation Current(A)	3.75	249
180	3 A Power Source Voltage(V)	209.3	250

Data name	Value	Data name	Value
97	Room A Op. Mode	Cooling	110
99	Room A Malfunction Code	0	111
100	1 A Room A Delta-D	9	112
103	1 A Room A Suction Air Temp.	70.70 (F)	114
104	7 1 A Room A Heat Exchanger Temp	49.10 (F)	115
110	3 A Room A Fan Frequency	1480	119
111	Room A Fan Tap	61	122
112	Room A Fan Angle	90	123
114	Room A Louver Angle	90	124
115	1 A Room A R/C Setpoint	64.40 (F)	125
119	Room A Airflow Setup (good)	H	126
122	Room A Airflow Setup (best)	H	127
123	Room A In/Out Transmission	Normal	128

# D-CHECKER ADDENDUM

Change label name in editor tab (F5)

The first screenshot shows the 'Label editor (F5)' tab with a table of data points. The second screenshot shows a 'Finish recording. Proceed?' dialog box with 'OK (F1)' and 'Cancel (Esc)' buttons highlighted. Below the dialog, the 'Stop Rec. (F8)' button is highlighted in the main interface.

When finished Recording, select Stop Rec. (F8)

## Playback and Exporting Data

The screenshot shows the D-Checker main menu with 'Play (F2)' highlighted. To the right, a 'Recorded data selection' window shows a table with one row selected. A blue arrow points from the 'Play (F2)' button to the table.

Select Play (F2)

Select desired recording

Add new folder to desktop with jobsite name

The first screenshot shows the 'Recorded data selection' window with 'CSV output (F2)' highlighted. The second screenshot shows a 'Save As' dialog box with 'DTP' folder selected and 'Open' button highlighted.

Select CSV output (F2)

Click Open then Save

# REVISION HISTORY

Month / Year	Version	Revised contents
10 / 2024	SiUS612414E	First edition

## CUSTOMER FEEDBACK

We are very interested in all product comments.

Please fill out the feedback form on the following link:

<https://www.goodmanmfg.com/about/contact-us>

You can also scan the QR code on the right to be directed to the feedback page.



**NOTE: SPECIFICATIONS AND PERFORMANCE DATA LISTED HEREIN ARE SUBJECT TO CHANGE WITHOUT NOTICE**

Visit our website at [www.goodmanmfg.com](http://www.goodmanmfg.com) for information on:

- Products
- Limited Warranties
- Customer Services
- Parts
- Contractor Programs and Training
- Financing Options

© 2024 Daikin Comfort Technologies Manufacturing, L.P.

SiUS612414E  
10/2024 AK.K