

VENDOR	MORRISON
VENDOR NO.	03-44305
NO. BLADES	48
DIM. "A"	9.50
DIM. "B"	10.62
DIM. "C"	10.60
DIM. "D"	NOT CONTROLLED
DIM. "E"	4.750
FINISH	GALVANIZED
BALANCE, OZ/IN	0.15
AXIAL RUNOUT	0.060
CONCENTRICITY	0.060

ECN	REV	DESCRIPTION	CHK	DR	DATE
0802208	A	INITIAL RELEASE	PDC	JEA	2-27-08
0802268	B	(A)I ADD SRV PT. 0150M00014S AND TABLE (A)I REMOVED NOTE 4	PC	DF	03-14-08

03-44305

03 - 44305 10-9 DD .50 CCW CC MP-P
11-NOV-00 14:45:57 #63 #990 01A

L11AP45TA

SET SCREW ONE 5/16 CUP POINT SQ HEAD
SET SCREW MUST NOT EXTEND INTO ID. OF HUB. MORRISON SET SCREW NOT CONTROLLED

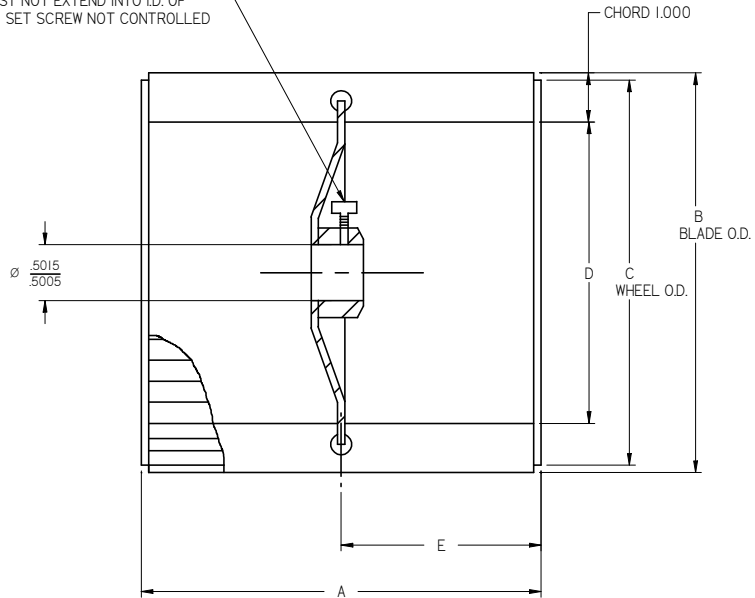

LABEL FORMAT 1

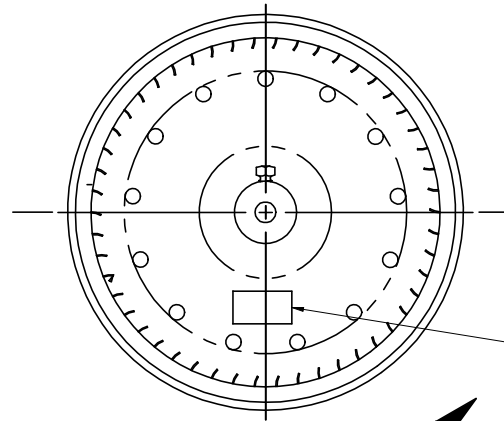

GOODMAN PT. NO. AND SUPPLIER PT. NO. TO BE IN THIS LOCATION. (SEE NOTE 8)

NOTES

1. WHEEL TO BE BALANCED WITHIN LIMITS SHOWN. BALANCE TYPE TO BE DYNAMIC.
2. AXIAL RUNOUT NOT TO EXCEED T.J.R. SHOWN
3. WHEEL TO BE CONCENTRIC WITH BORE WITHIN T.J.R. SHOWN.
4. REMOVED NOTE.
5. DISC POSITION: CONCAVE FACING HUB
6. ROTATION OF WHEEL FACING HUB: CCW
7. GOODMAN PART NUMBER TO APPLIED TO EXTERIOR OF BULK PACKING.
8. GOODMAN PT. NO. AND SUPPLIER PT. NO. TO BE STAMPED ON EACH PART (INK STAMPED OR LABEL PERMISSIBLE) AS SHOWN. SUPPLIER PT. NO. MAYBE FOLLOWED BY 1 OR MORE DIGITS, FOR SUPPLIER INTERNAL USE ONLY.
9. HUB OF BLOWER WHEEL MUST WITHSTAND A MINIMUM TORQUE OF 500 IN/LBS. OR 41.6 FT./LBS. ALTERNATELY IN BOTH DIRECTIONS

SPECIAL CHARACTERISTICS:

⊕ = 6SIGMA ⊕ = CRITICAL CHARACTERISTIC ⊕ = SIGNIFICANT CHARACTERISTIC

COMPONENTS AND MATERIALS SPECIFIED HEREIN WILL ALSO CONFORM TO THE APPLICABLE SECTION OF GOODMAN MSP 824.01 WORKMANSHIP STANDARD FOR FIT, FEEL AND FINISH.

CONFIDENTIAL PROPERTY OF THE GOODMAN MANUFACTURING COMPANY, L.P. NOT TO BE DISCLOSED TO OTHERS, COPIED, OR USED FOR ANY PURPOSE EXCEPT AS AUTHORIZED IN WRITING. MUST BE RETURNED UPON DEMAND, ON COMPLETION OF ORDER, OR OTHER PURPOSE FOR WHICH IT WAS LENT.

THE GOODMAN MANUFACTURING COMPANY, L.P.

DRAWING TO BE INTERPRETED IN ACCORDANCE WITH ASME Y14.100 UNLESS OTHERWISE NOTED		WHEEL, BLOWER	
DWN BY: J ANDERSON	ENG: S GUSHARD	DO NOT SCALE DRAWING	REV
CHK BY: PAMELA CYRILIEN	DATE: 2-27-08	SHT 1 OF 1	B
		0150M00014	

TOLERANCES:
ANGLES ± 15°
X: ± .1
XX: ± .03
XXX: ± .015
HOLE Ø: ± .005
TUBE CUT LG: ± .063

8

7

6

5

4

3

2

1