

# INDOOR COILS

CAPE, CAPEA, CAPT, CAPTA, CAPF, CAPFA, CAUF, CAUFA, CHPE, CHPT, CHPTA, CHPF AND CSCF

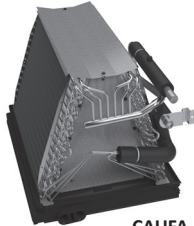

CAPEA / CAPE  
Cased with EEV



CAUFA  
Uncased

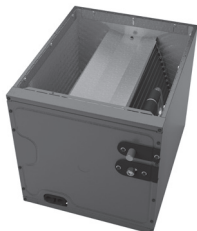

CAPFA  
Cased



CHPT  
Cased with Internal TXV



CAPTA  
Cased with Internal TXV



CAPF  
Cased

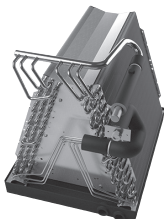

CAUF  
Uncased



CHPTA  
Cased with Internal TXV



CHPF  
Horizontal "A"

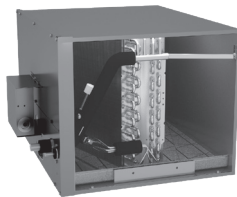

CHPE  
Horizontal "A" with EEV

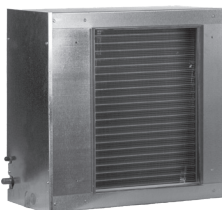

CSCF  
Horizontal Slab



CAPT  
Cased with Internal TXV

CASED, PAINTED UPFLOW/DOWNFLOW,  
 UNCASED UPFLOW/DOWNFLOW,  
 HORIZONTAL "A", AND HORIZONTAL SLAB

### Standard Features

- All-Aluminum evaporator coil
- Optimized for use with R-410A refrigerant
- Some models suitable for use with R-410A or R-22 refrigerant
- CAPE, CAPEA and CHPE models feature:
  - Factory-installed electronic expansion valve (EEV) for precise refrigerant control
  - Compatibility with Amana Brand smart thermostat and other Amana communicating equipment
  - Cooling and heat pump applications
  - Fault recall of six most recent faults
- CAPT, CAPTA, CHPT and CHPTA models feature factory-installed thermal expansion valves for cooling and heat pump applications
- Check flowrator for cooling and heat pump applications
- Vertical and horizontal models available
- 21" depth for easier attic access
- CAPFA/CAPTA/CHPTA/CAPEA models include a single front access panel
- Foil-faced insulation covers the internal casing to reduce cabinet condensation
- Galvanized, leather grain-embossed finish
- Rust resistant, thermoplastic drain pans featuring a low water-retention design
- DecaBDE-free thermoplastic drain pan with secondary drain connections
- UV-resistant drain pan
- AHRI certified; ETL listed

**Note:** Do not use these coils on oil furnaces or any applications where the temperature on the drain pan may exceed 300° F. If these coils are applied with an oil furnace or another application where high temperatures threaten or jeopardize the durability of the drain pan, you must replace the factory-installed drain pan with a high-temperature drain pan. High-temperature drain pan kits are available as field-installed accessories.



\* Complete warranty details available from your local dealer or at [www.amana-hac.com](http://www.amana-hac.com). To receive the 10-Year Parts Limited Warranty, online registration must be completed within 60 days of installation. Online registration is not required in California or Québec.

NOMENCLATURE

	C	A	U	F	1824	A	6	AA	
	1	2	3	4	5,6,7,8	9	10	11,12	
<b>Product Category</b>									<b>ENGINEERING</b>
C - Indoor Coil									Major/Minor Revisions
<b>Application</b>									<b>REFRIGERANT</b>
A - Upflow/Downflow Coil									6 - R-22 / R-410A
H - Horizontal A Coil									2 - R-22
S - Horizontal Slab Coil									4 - R-410A
<b>Cabinet Finish</b>									<b>NOMINAL WIDTH FOR GAS FURNACE</b>
U - Uncased      C - Unpainted									A - Fits 14" Furnace Cabinet
P - Painted									B - Fits 17½" Furnace Cabinet
									C - Fits 21" Furnace Cabinet
<b>Expansion Device</b>									N - Does Not Apply (horizontal slab coil)
F - Flowrator									
T - TXV									
E - Electronic Expansion Valve									
					<b>NOMINAL CAPACITY RANGE @ 13 SEER</b>				
					1824 - 1½ to 2 Tons	3642 - 3 to 3½ Tons			
					3030 - 2½ Tons	3743 - 3 to 3½ Tons			
					3131 - 2½ Tons	4860 - 4 to 5 Tons			
					3137 - 2 ½ to 3 Tons	4961 - 4 to 5 Tons			
					3636 - 3 Tons				

	C	A	P	F	A	1 8	1 4	A	6	A	A			
	1	2	3	4	5	6 7	8 9	10	11	12	13			
<b>Product Category</b>														
C Indoor Coil												<b>Engineering</b>		
<b>Application</b>												Major/ Minor Revisions		
A Upflow/Downflow												<b>Refrigerant</b>		
H Horizontal												2 - R-22 only		
												4 - R-410A only		
<b>Cabinet Finish</b>												6 - R-22 or R-410A compatible		
U Uncased												<b>Nominal Width for Gas Furnace</b>		
P Cased - Painted												A - 14" Width      D - 24.5" Width		
C Cased - Unpainted												B - 17.5" Width      N - Not Applicable (Slab Coil)		
<b>Expansion Device</b>												C - 21" Width		
F Flowrator														
T TXV														
E Electronic Expansion Device														
<b>Coil Configuration</b>												<b>Cased Height</b>		
A A Coil												14 - 14" Coil      22 - 22" Coil		
S Slab												18 - 18" Coil      26 - 26" Coil		
											30 - 30" Coil			
												<b>Nominal Capacity Range</b>		
			17, 18 - 1.5 Tons			29, 30 - 2.5 Tons			42 - 3.5 Tons			60 - 5 Tons		
			23, 24 - 2 Tons			35, 36 - 3 Tons			48 - 4 Tons					

# CAUF — UNCASED UPFLOW/DOWNFLOW INDOOR COILS



## SPECIFICATIONS

MODEL	DIMENSIONS			NOMINAL TONS	CONNECTION		PISTON SIZE* (IN.)	SHIP WEIGHT (LBS)
	W	H	A		LIQUID	SUCTION		
CAUF3137B6	16½"	27"	25"	2½-3	¾"	¾"	.071	53
CAUF3743C6	20"	28⅞"	25"	3-3½	¾"	¾"	.078	46
CAUF3743D6	23"	27⅞"	25"	3-3½	¾"	¾"	.078	43
CAUF4860C6	20"	28"	25"	4-5	¾"	¾"	.093	48
CAUF4860D6	23"	28"	25"	4-5	¾"	¾"	.093	39
CAUF4961C6	20"	28"	25"	4-5	¾"	¾"	.093	54
CAUF4961D6	23"	27"	25"	4-5	¾"	¾"	.093	59

\* Shipped with Coil

Note: For a properly matched system and piston sizing information, refer to Daikin piston kit chart of the corresponding Daikin outdoor unit.

## DIMENSIONS

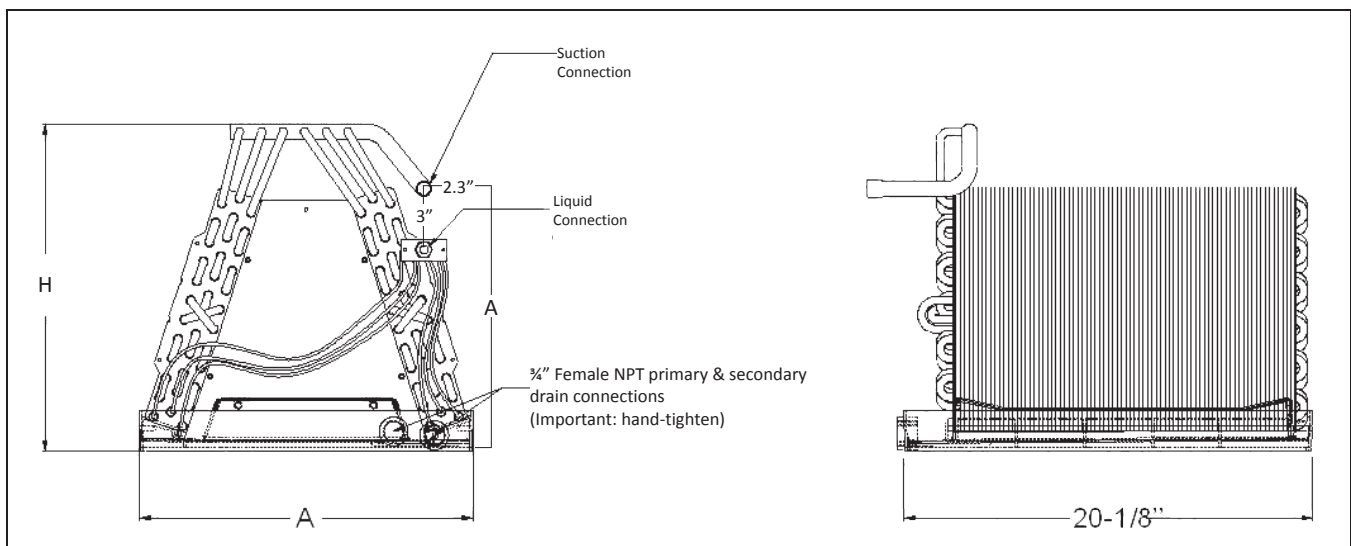

# CAUFA — UNCASSED UPFLOW/DOWNFLOW INDOOR COILS



## SPECIFICATIONS

MODEL	DIMENSIONS				NOMINAL TONS	CONNECTION		PISTON SIZE* (IN.)	SHIP WEIGHT (LBS)
	W	D	H	A		LIQUID	SUCTION		
CAUFA1818A6	12½"	20⅝"	14¾"	12¾"	1½	⅜"	¼"	0.055	18
CAUFA1818B6	16"	20⅝"	14½"	12¾"	1½	⅜"	¼"	0.055	20
CAUFA1818C6	19½"	20⅝"	14¾"	12¾"	1½	⅜"	¼"	0.055	26
CAUFA2418A6	12½"	20⅝"	14¾"	12¾"	2	⅜"	¼"	0.057	18
CAUFA2418B6	16"	20⅝"	14½"	12¾"	2	⅜"	¼"	0.057	20
CAUFA2418C6	19½"	20⅝"	14¾"	12¾"	2	⅜"	¼"	0.057	26
CAUFA2422A6	12½"	20⅝"	18"	17"	2	⅜"	¼"	0.059	26
CAUFA2422B6	16"	20⅝"	17¾"	16¾"	2	⅜"	¼"	0.059	28
CAUFA2422C6	19½"	20⅝"	17½"	16¾"	2	⅜"	¼"	0.059	30
CAUFA3022A6	12½"	20⅝"	18"	17"	2½	⅜"	¼"	0.063	26
CAUFA3022B6	16"	20⅝"	17¾"	16¾"	2½	⅜"	¼"	0.063	28
CAUFA3022C6	19½"	20⅝"	17½"	16¾"	2½	⅜"	¼"	0.063	30
CAUFA3022D6	23"	20⅝"	17¾"	16¾"	2½	⅜"	¼"	0.063	32
CAUFA3626B6	16"	20⅝"	21"	20¾"	3	⅜"	⅞"	0.065	30
CAUFA3626C6	19½"	20⅝"	20¾"	20¾"	3	⅜"	⅞"	0.065	31
CAUFA3626D6	23"	20⅝"	20¾"	20¾"	3	⅜"	⅞"	0.065	35
CAUFA4226B6	16"	20⅝"	24¾"	20¾"	3½	⅜"	⅞"	0.071	28
CAUFA4226C6	19½"	20⅝"	24"	20¾"	3½	⅜"	⅞"	0.071	30
CAUFA4226D6	23"	20⅝"	23¾"	20¾"	3½	⅜"	⅞"	0.071	33

\* Shipped with Coil

Note: For a properly matched system and piston sizing information, refer to Daikin piston kit chart of the corresponding Daikin outdoor unit.

## DIMENSIONS

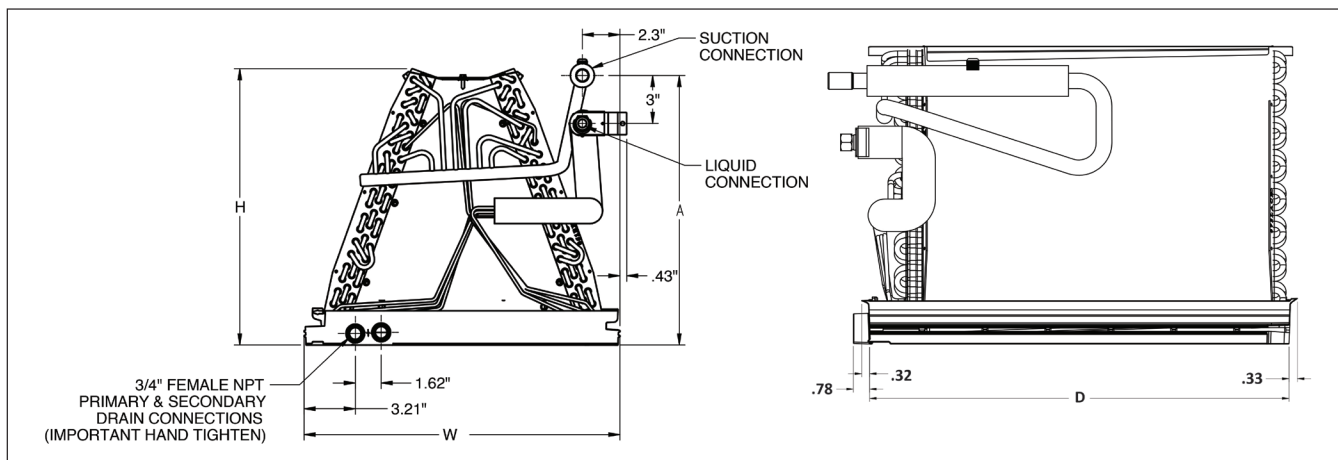

# CAPFA — CASED UPFLOW/DOWNFLOW INDOOR COILS



## SPECIFICATIONS

MODEL	CABINET DIMENSIONS				NOMINAL TONS	CONNECTION		PISTON SIZE* (IN.)	SHIP WEIGHT (LBS)
	W	D	H	A		LIQUID	SUCTION		
CAPFA1818A6	14"	21"	18"	14"	1½	⅜"	¼"	0.055	33
CAPFA1818B6	17½"	21"	18"	14"	1½	⅜"	¼"	0.055	38
CAPFA1818C6	21"	21"	18"	14"	1½	⅜"	¼"	0.055	43
CAPFA2418A6	14"	21"	18"	14"	2	⅜"	¼"	0.057	33
CAPFA2418B6	17½"	21"	18"	14"	2	⅜"	¼"	0.057	38
CAPFA2418C6	21"	21"	18"	14"	2	⅜"	¼"	0.057	43
CAPFA2422A6	14"	21"	22"	18"	2	⅜"	¼"	0.059	41
CAPFA2422B6	17½"	21"	22"	18"	2	⅜"	¼"	0.059	45
CAPFA2422C6	21"	21"	22"	18"	2	⅜"	¼"	0.059	50
CAPFA3022A6	14"	21"	22"	18"	2½	⅜"	¼"	0.063	41
CAPFA3022B6	17½"	21"	22"	18"	2½	⅜"	¼"	0.063	45
CAPFA3022C6	21"	21"	22"	18"	2½	⅜"	¼"	0.063	50
CAPFA3022D6	24½"	21"	22"	18"	2½	⅜"	¼"	0.063	52
CAPFA3626B6	17½"	21"	26"	22"	3	⅜"	⅞"	0.065	47
CAPFA3626C6	21"	21"	26"	22"	3	⅜"	⅞"	0.065	49
CAPFA3626D6	24½"	21"	26"	22"	3	⅜"	⅞"	0.065	56
CAPFA4226B6	17½"	21"	26"	22"	3½	⅜"	⅞"	0.071	51
CAPFA4226C6	21"	21"	26"	22"	3½	⅜"	⅞"	0.071	54
CAPFA4226D6	24½"	21"	26"	22"	3½	⅜"	⅞"	0.071	59

\* Shipped with Coil

**Note:** For a properly matched system and piston sizing information, refer to Daikin piston kit chart of the corresponding Daikin outdoor unit.

## DIMENSIONS

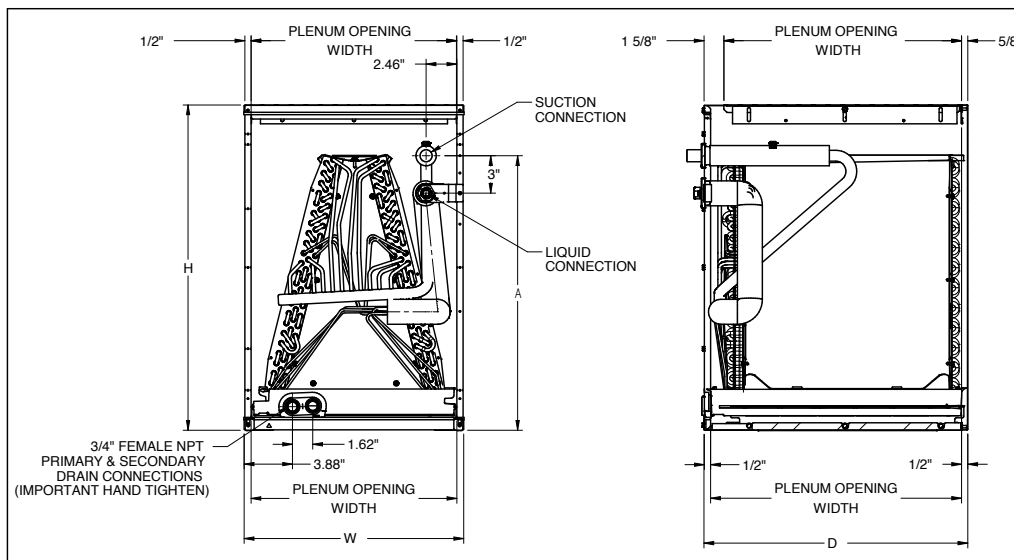

# CAPF — CASED UPFLOW/DOWNFLOW INDOOR COILS



## SPECIFICATIONS

MODEL	CABINET DIMENSIONS			NOMINAL TONS	CONNECTION		PISTON SIZE* (IN.)	SHIP WEIGHT (LBS)
	W	D	H		LIQUID	SUCTION		
CAPF3137B6	17½"	21"	30"	2½-3	⅜"	¾"	.071	53
CAPF3743C6	21"	21"	30"	3-3½	⅜"	⅞"	.078	63
CAPF3743D6	24½"	21"	30"	3-3½	⅜"	⅞"	.078	75
CAPF4860C6	21"	21"	30"	4-5	⅜"	⅞"	.093	65
CAPF4860D6	24½"	21"	30"	4-5	⅜"	⅞"	.093	68
CAPF4961C6	21"	21"	30"	4-5	⅜"	⅞"	.093	73
CAPF4961D6	24½"	21"	30"	4-5	⅜"	⅞"	.093	76

\* Shipped with Coil

Note: For a properly matched system and piston sizing information, refer to Daikin piston kit chart of the corresponding Daikin outdoor unit.

## DIMENSIONS

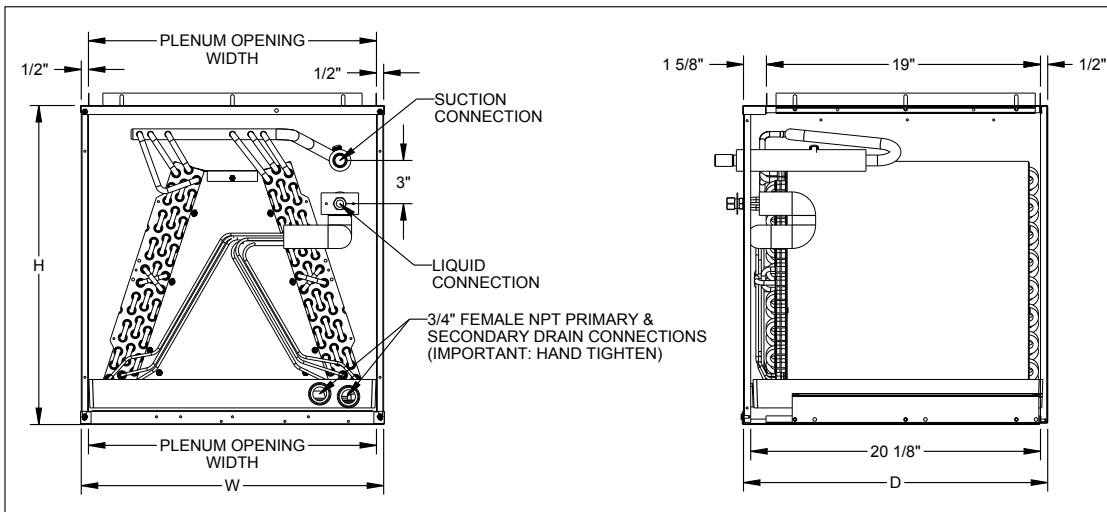

# CAPEA / CAPE — CASED UPFLOW/DOWNFLOW INDOOR COILS



## SPECIFICATIONS

MODEL	CABINET DIMENSIONS			NOMINAL TONS	CONNECTION		SHIP WEIGHT (LBS)
	W	D	H		LIQUID	SUCTION	
CAPEA1818B4	17½"	21"	18"	1½-2	¾"	¾"	43
CAPEA1818C4	21"	21"	18"	1½-2	¾"	¾"	45
CAPEA2422B4	17½"	21"	22"	2-2½	¾"	¾"	48
CAPEA2422C4	21"	21"	22"	2-2½	¾"	¾"	51
CAPEA3026B4	17½"	21"	26"	3	¾"	7/8"	54
CAPEA3026C4	21"	21"	26"	3	¾"	7/8"	57
CAPEA3026D4	24½"	21"	26"	3	¾"	7/8"	62
CAPEA4830C4	21"	21½"	30"	3½ - 4	¾"	7/8" or 1½"	67
CAPEA6030D4	24½"	21½"	30"	4-5	¾"	7/8" or 1½"	76

MODEL	CABINET DIMENSIONS			NOMINAL TONS	CONNECTION		SHIP WEIGHT (LBS)
	W	D	H		LIQUID	SUCTION	
CAPE4860C4	21"	21"	30"	3½-4	¾"	7/8"	71
CAPE4860D4	24½"	21"	30"	3½-4	¾"	7/8"	73
CAPE4961C4	21"	21"	30"	4-5	¾"	7/8"	78
CAPE4961D4	24½"	21"	30"	4-5	¾"	7/8"	80

## DIMENSIONS

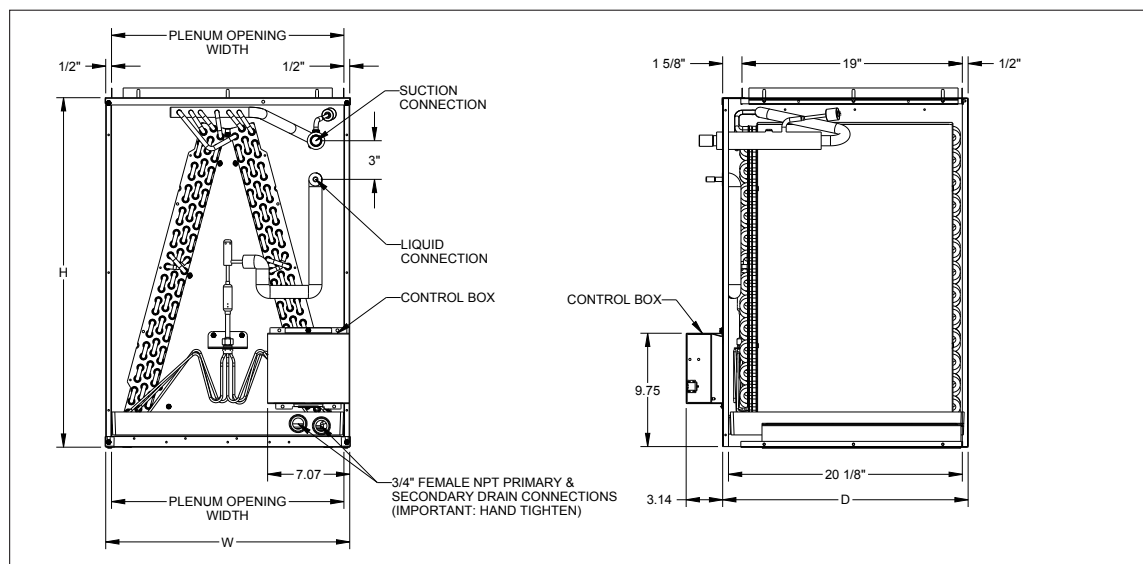
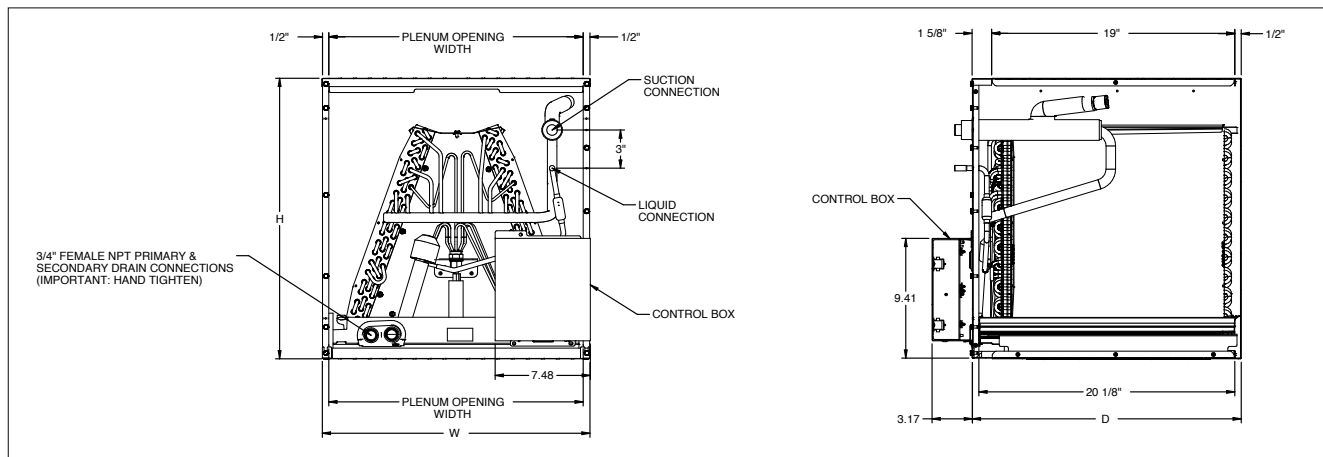

# CAPT — CASED UPFLOW/DOWNFLOW INDOOR COILS WITH INTERNAL TXV



## SPECIFICATIONS

MODEL	CABINET DIMENSIONS			NOMINAL TONS	CONNECTION		SHIP WEIGHT (LBS)
	W	D	H		LIQUID	SUCTION	
CAPT4961C4	21"	21"	30"	4-5	3/8"	7/8"	73
CAPT4961D4	24 1/2"	21"	30"	4-5	3/8"	7/8"	76

## DIMENSIONS

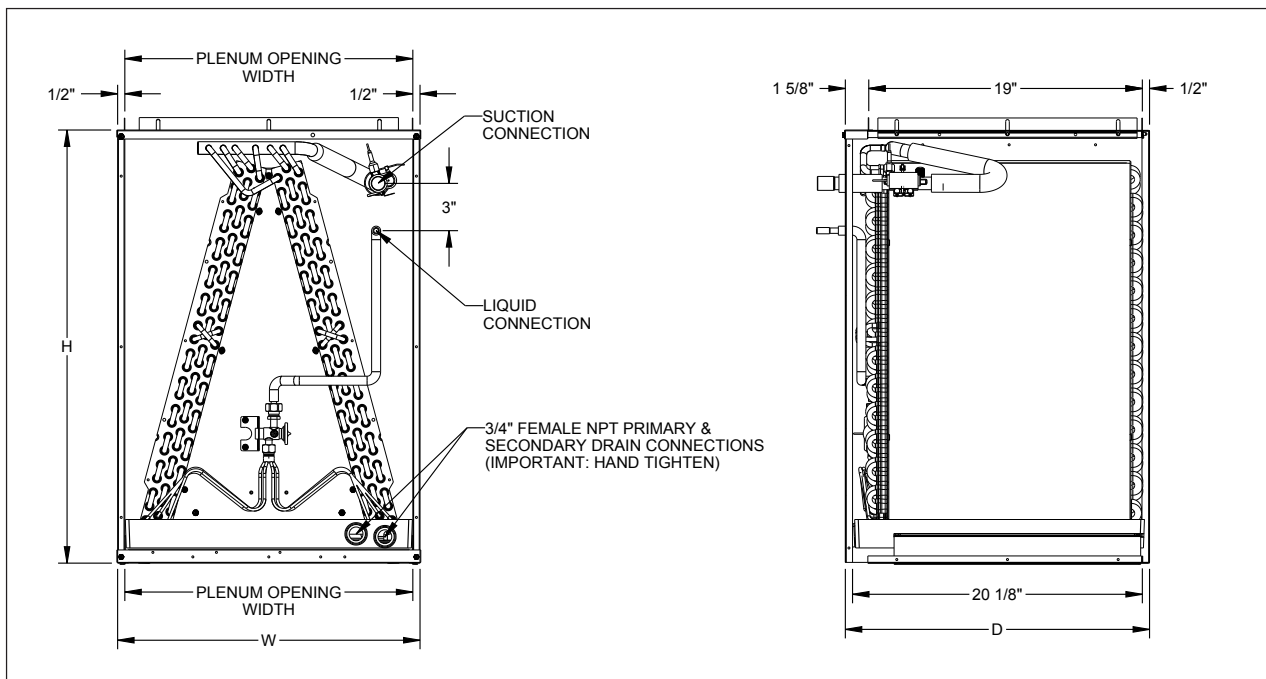

# CHPF, CHPE — PAINTED CASED HORIZONTAL “A” INDOOR COIL



## SPECIFICATIONS

MODEL	CABINET DIMENSIONS			PLENUM		NOMINAL TONS	CONNECTION		PISTON SIZE (IN.) <sup>2</sup>	SHIP WEIGHT (LBS)
	D	W	H	D	H		LIQUID	SUCTION		
CHPF3636B6	21½"	26"	17½"	19"	16½"	3	⅜"	¼"	.074	50
CHPF3642C6	21½"	26"	21"	19"	20"	3-3½	⅜"	¼"	.076	63
CHPF3743C6	21½"	26"	21"	19"	20"	3-3½	⅜"	⅝"	.076	63
CHPF4860D6	21½"	26"	24½"	19"	23½"	4-5	⅜"	⅝"	.093	77

<sup>1</sup> (ft<sup>2</sup>)

<sup>2</sup> Shipped with Coil

Note: For a properly matched system and piston sizing information, refer to Daikin piston kit chart of the corresponding Daikin outdoor unit.

MODEL	CABINET DIMENSIONS			PLENUM		NOMINAL TONS	CONNECTION		PISTON SIZE (IN.) <sup>2</sup>	SHIP WEIGHT (LBS)
	D	W	H	D	H		LIQUID	SUCTION		
CHPE2430B4	21½"	26"	17½"	19"	16½"	1½	⅜"	¼"	N/A	56
CHPE3636B4	21½"	26"	17½"	19"	16½"	2-3	⅜"	¼"	N/A	59
CHPE3642C4	21½"	26"	21"	19"	20"	2-2 ½	⅜"	¼"	N/A	62
CHPE3743C4	21½"	26"	21"	19"	20"	3-4	⅜"	⅝"	N/A	68
CHPE3743D4	21½"	26"	24½"	19"	23½"	3-3½	⅜"	⅝"	N/A	72
CHPE4860D4	21½"	26"	24½"	19"	23½"	4-5	⅜"	⅝"	N/A	79

## DIMENSIONS

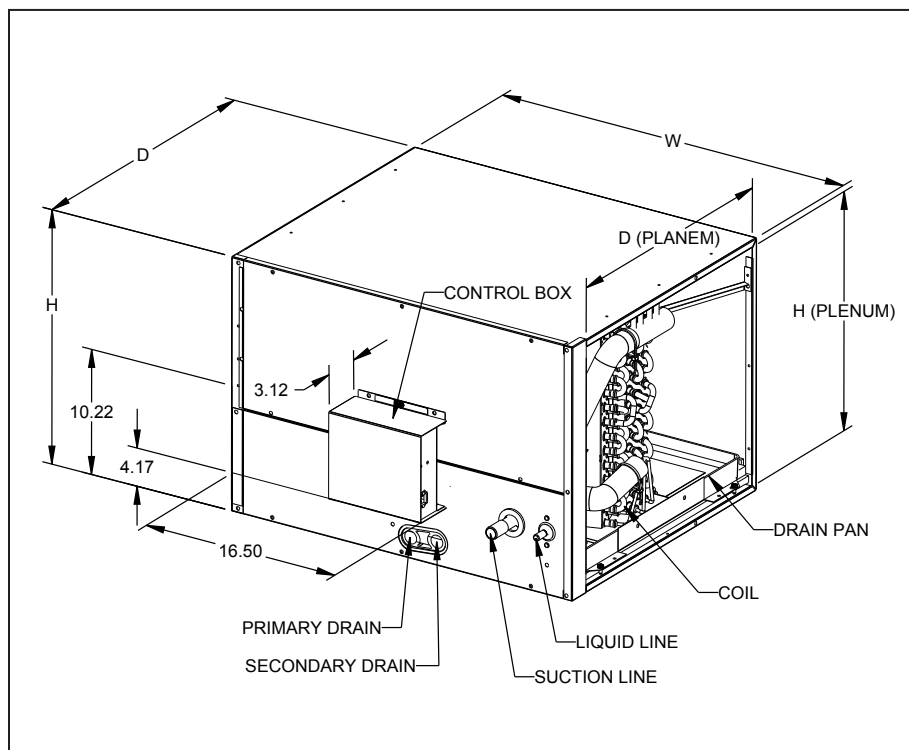

# CSCF — HORIZONTAL SLAB EVAPORATOR COILS



## SPECIFICATIONS

MODEL	CAPACITY (TONS)	EVAP COIL FACE AREA <sup>1</sup>	CONNECTION SIZE		PISTON SIZE (IN.)*	SHIP WEIGHT (LBS)
			LIQUID	SUCTION		
CSCF1824N6	1½-2	3½	¾"	¾"	.059	43
CSCF3036N6	2½-3	4½	¾"	7/8"	.074	52.5
CSCF3642N6	3-3½	5½	¾"	7/8"	.078	43
CSCF4860N6	4-5	5½	¾"	7/8"	.093	60

\* Shipped with Coil

Note: For a properly matched system and piston sizing information, refer to Daikin piston kit chart of the corresponding Daikin outdoor unit.

## DIMENSIONS

MODEL	CABINET DIMENSIONS			PLENUM OPENING	
	D (A)	W	H	D (B)	H
CSCF1824N6	25½"	12"	25"	16"	21"
CSCF3036N6	33½"	12"	25"	24"	21"
CSCF3642N6	39½"	12"	25"	30"	21"
CSCF4860N6	39½"	12"	25"	30"	21"

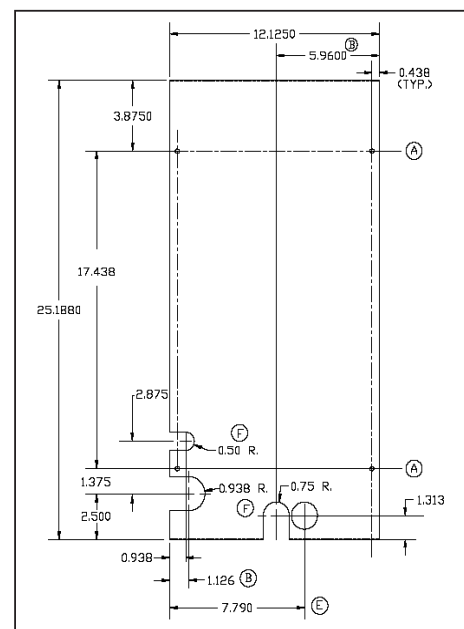
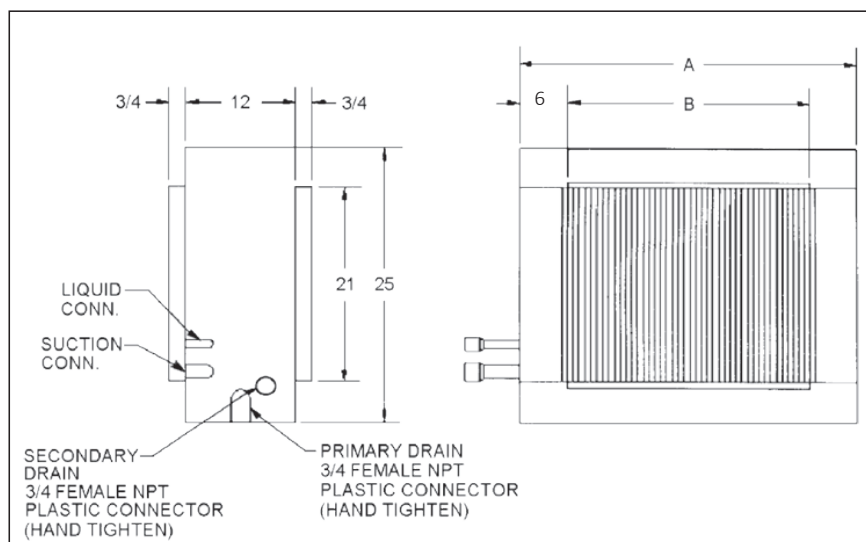

DETAIL OF ACCESS DOOR

# CAPTA — CASED UPFLOW/DOWNFLOW INDOOR COILS



## SPECIFICATIONS

MODEL	CABINET DIMENSIONS			NOMINAL TONS	CONNECTION		SHIP WEIGHT (LBS)
	W	D	H		LIQUID	SUCTION	
CAPTA1818A4	14"	21"	18"	1½	⅜"	¼"	36
CAPTA1818B4	17½"	21"	18"	1½	⅜"	¼"	41
CAPTA2422A4	14"	21"	22"	2	⅜"	¼"	44
CAPTA2422B4	17½"	21"	22"	2	⅜"	¼"	48
CAPTA2422C4	21"	21"	22"	2	⅜"	¼"	53
CAPTA3022A4	14"	21"	22"	2½	⅜"	¼"	44
CAPTA3022B4	17½"	21"	22"	2½	⅜"	¼"	48
CAPTA3022C4	21"	21"	22"	2½	⅜"	¼"	53
CAPTA3026B4	17½"	21"	26"	2½	⅜"	⅝"	50
CAPTA3026C4	21"	21"	26"	2½	⅜"	⅝"	52
CAPTA3626B4	17½"	21"	26"	3	⅜"	⅝"	54
CAPTA3626C4	21"	21"	26"	3	⅜"	⅝"	57
CAPTA4230C4	21"	21"	30"	3½	⅜"	⅝"	63
CAPTA4230D4	24.5"	21"	30"	3½	⅜"	⅝"	66

Note: For a properly matched system and piston sizing information, refer to Daikin piston kit chart of the corresponding Daikin outdoor unit.

## DIMENSIONS

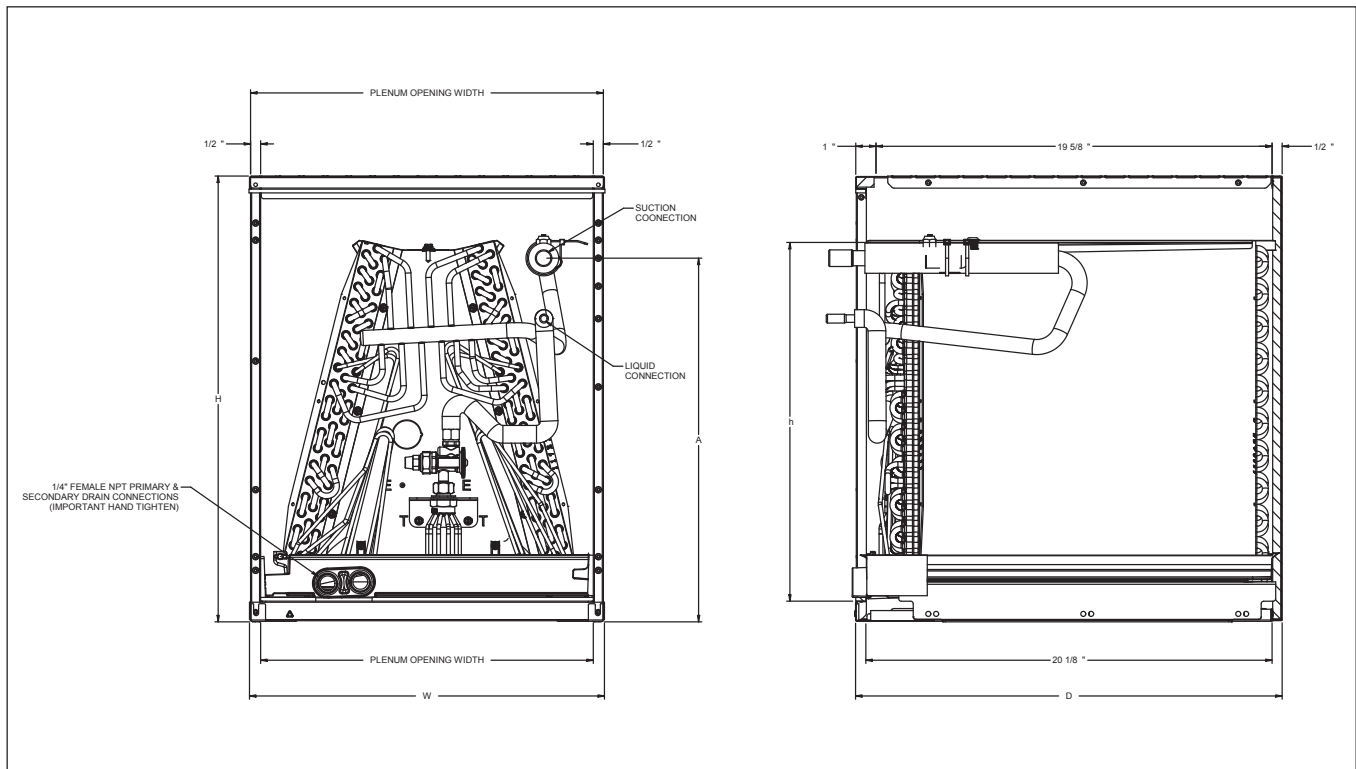

# CHPTA, CHPT— CASED HORIZONTAL INDOOR COILS



## SPECIFICATIONS

MODEL	CABINET DIMENSIONS			NOMINAL TONS	CONNECTION		SHIP WEIGHT (LBS)
	W	D	H		LIQUID	SUCTION	
CHPTA1822A4	22"	21"	14"	1½	¾"	¾"	48
CHPTA1822B4	22"	21"	17½"	1½	¾"	¾"	52
CHPTA2426B4	26"	21"	17½"	2	¾"	¾"	57
CHPTA2426C4	26"	21"	21"	2	¾"	7⁄8"	59
CHPTA3026B4	26"	21"	17½"	2½	¾"	7⁄8"	61
CHPTA3026C4	26"	21"	21"	2½	¾"	7⁄8"	64
CHPTA3630B4	30"	21"	17½"	3	¾"	7⁄8"	66
CHPTA3630C4	30"	21"	21"	3	¾"	7⁄8"	70
CHPT4860D4**	26"	21½"	24½"	3½ - 5	¾"	7⁄8"	81

Note: For a properly matched system and piston sizing information, refer to Daikin piston kit chart of the corresponding Daikin outdoor unit.

## DIMENSIONS

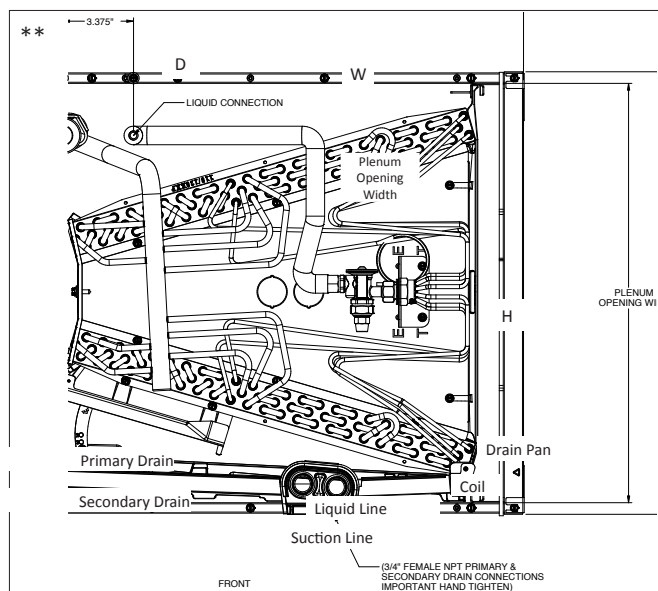
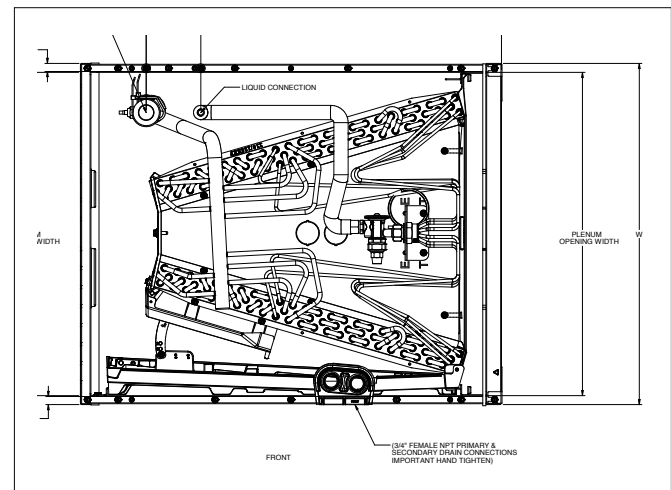
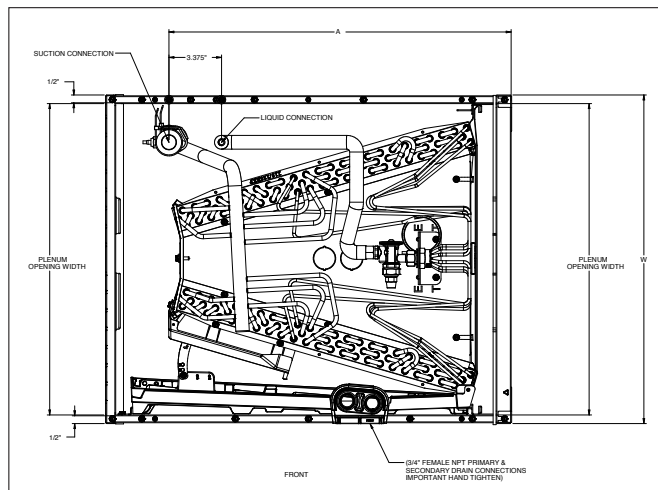

# AIRFLOW DATA FOR CAUF, CAUFA & CAPF, CAPFA & CAPEA & CAPE

AIR QUANTITY (SCFM) VS. PRESSURE DROP (IN. WC)

	SCFM	400	500	600	700	800	900	1000	1100	1200	1300	1400	1500
<b>CA*FA1818A6*</b>	Wet	0.110	0.160	0.220	0.290	0.370	0.460	0.550	0.650	0.760	0.830	0.950	1.080
	Dry	0.074	0.100	0.132	0.168	0.220	0.264	0.317	0.377	0.434	0.503	0.584	0.667
<b>CA*FA1818B6*</b>	Wet	0.100	0.140	0.190	0.250	0.310	0.380	0.450	0.530	0.610	0.670	0.770	0.870
	Dry	0.066	0.087	0.115	0.144	0.175	0.218	0.260	0.301	0.347	0.401	0.460	0.521
<b>CA*FA1818C6*</b>	Wet	0.093	0.130	0.172	0.221	0.275	0.335	0.400	0.471	0.548	0.631	0.719	0.813
	Dry	0.064	0.086	0.110	0.139	0.170	0.205	0.243	0.284	0.328	0.376	0.427	0.481
<b>CA*FA2422A6*</b>	Wet	0.091	0.128	0.181	0.240	0.304	0.374	0.454	0.541	0.635	0.733	0.837	0.958
	Dry	0.084	0.112	0.148	0.191	0.241	0.299	0.366	0.440	0.522	0.611	0.704	0.803
<b>CA*FA2422B6*</b>	Wet	0.084	0.117	0.155	0.199	0.249	0.304	0.364	0.430	0.502	0.578	0.661	0.748
	Dry	0.055	0.077	0.102	0.130	0.162	0.196	0.234	0.276	0.320	0.368	0.419	0.473
<b>CA*FA2422C6*</b>	Wet	0.064	0.091	0.120	0.153	0.189	0.228	0.269	0.314	0.361	0.411	0.464	0.520
	Dry	0.055	0.074	0.095	0.119	0.146	0.175	0.207	0.242	0.280	0.320	0.363	0.408
<b>CA*FA3022A6*</b>	Wet	0.091	0.128	0.181	0.240	0.304	0.374	0.454	0.541	0.635	0.733	0.837	0.958
	Dry	0.084	0.112	0.148	0.191	0.241	0.299	0.366	0.440	0.522	0.611	0.704	0.803
<b>CA*FA3022B6*</b>	Wet	0.084	0.117	0.155	0.199	0.249	0.304	0.364	0.430	0.502	0.578	0.661	0.748
	Dry	0.055	0.077	0.102	0.130	0.162	0.196	0.234	0.276	0.320	0.368	0.419	0.473
<b>CA*FA3022C6*</b>	Wet	0.064	0.091	0.120	0.153	0.189	0.228	0.269	0.314	0.361	0.411	0.464	0.520
	Dry	0.055	0.074	0.095	0.119	0.146	0.175	0.207	0.242	0.280	0.320	0.363	0.408
<b>CA*FA3626A6*</b>	Wet	0.064	0.089	0.118	0.149	0.184	0.222	0.262	0.306	0.353	0.402	0.455	0.511
	Dry	0.055	0.072	0.092	0.114	0.139	0.167	0.198	0.231	0.267	0.306	0.348	0.392
<b>CA*FA3626B6*</b>	Wet	0.067	0.085	0.109	0.136	0.167	0.203	0.244	0.288	0.337	0.390	0.447	0.508
	Dry	0.045	0.061	0.080	0.103	0.130	0.159	0.193	0.229	0.269	0.313	0.360	0.410
<b>CA*FA3626C6*</b>	Wet	0.057	0.079	0.103	0.132	0.163	0.199	0.237	0.280	0.325	0.374	0.427	0.483
	Dry	0.041	0.056	0.072	0.091	0.112	0.134	0.159	0.185	0.214	0.245	0.277	0.312
<b>CA*FA3626D6*</b>	Wet	0.055	0.076	0.099	0.124	0.152	0.182	0.215	0.250	0.288	0.328	0.370	0.415
	Dry	0.042	0.055	0.070	0.088	0.108	0.130	0.154	0.180	0.208	0.239	0.271	0.306
<b>CA*FA4226A6*</b>	Wet	0.046	0.064	0.087	0.113	0.144	0.171	0.211	0.255	0.299	0.345	0.395	0.450
	Dry	0.015	0.038	0.063	0.089	0.117	0.146	0.180	0.217	0.255	0.297	0.342	0.393
<b>CA*FA4226B6*</b>	Wet	0.059	0.068	0.082	0.100	0.121	0.147	0.176	0.208	0.243	0.281	0.321	0.364
	Dry	0.033	0.046	0.061	0.077	0.095	0.116	0.138	0.162	0.187	0.215	0.244	0.276
<b>CA*FA4226C6*</b>	Wet	0.035	0.055	0.076	0.097	0.118	0.140	0.162	0.186	0.211	0.236	0.262	0.291
	Dry	NA	NA	NA	0.023	0.051	0.078	0.105	0.131	0.157	0.183	0.210	0.237

## AIRFLOW DATA FOR CAUF, CAUFA & CAPF, CAPFA & CAPEA & CAPE (CONT.)

AIR QUANTITY (SCFM) VS. PRESSURE DROP (IN. WC)

<b>CA*F3137B6*</b>	Wet	600	700	800	900	1000	1100	1200	1300	1400	1500	1600	1700	1800	1900	2000	2100
	Dry	0.080	0.100	0.130	0.160	0.190	0.220	0.250	0.290	0.340	0.380	0.430	0.48	0.530	0.590	0.660	0.710
<b>CA*F3743C6*</b>	Wet	800	900	1000	1100	1200	1300	1400	1500	1600	1700	1800	1900	2000	2100	2200	
	Dry	0.073	0.083	0.103	0.113	0.133	0.153	0.163	0.183	0.213	0.233	0.263	0.293	0.323	0.383	0.423	
<b>CA*F3743D6*</b>	Wet	0.074	0.080	0.089	0.107	0.120	0.129	0.138	0.169	0.188	0.209	0.229	0.251	0.273	0.279	0.306	
	Dry	0.046	0.056	0.074	0.076	0.086	0.107	0.110	0.126	0.147	0.160	0.176	0.196	0.210	0.230	0.253	
<b>CA*F4860C6*</b>	Wet	1000	1100	1200	1300	1400	1500	1600	1700	1800	1900	2000	2100	2200			
	Dry	0.160	0.177	0.194	0.206	0.246	0.264	0.264	0.290	0.327	0.349	0.395	0.460	0.485			
<b>CA*F4860D6*</b>	Wet	0.138	0.156	0.177	0.196	0.226	0.247	0.275	0.298	0.327	0.349	0.395	0.460	0.485			
	Dry	0.126	0.138	0.157	0.176	0.187	0.200	0.205	0.210	0.230	0.250	0.280	0.300	0.417			
<b>CA*F4961C6*</b>	Wet	400	500	600	700	800	900	1000	1100	1200	1300	1400	1500	1600	1700	1800	1900
	Dry	0.202	0.219	0.236	0.248	0.288	0.306	0.306	0.307	0.332	0.351	0.406	0.431	0.604			
<b>CA*F4961D6*</b>	Wet	0.140	0.158	0.179	0.198	0.228	0.249	0.277	0.300	0.329	0.351	0.397	0.462	0.487			
	Dry	0.128	0.140	0.159	0.178	0.189	0.202	0.206	0.212	0.232	0.252	0.282	0.302	0.419			
<b>CAPEA4830C4</b>	Dry	0.038	0.05	0.064	0.081	0.1	0.119	0.139	0.166	0.191	0.219	0.247	0.276	0.309	0.344	0.382	0.423
	Wet	0.04	0.057	0.076	0.099	0.126	0.157	0.189	0.223	0.26	0.302	0.348	0.399	0.459	0.517	0.578	0.64
<b>CAPEA6030D4</b>	Dry	0.068	0.083	0.099	0.116	0.134	0.153	0.173	0.196	0.219	0.243	0.27	0.296	0.323	0.354	0.394	0.437
	Wet	0.077	0.095	0.113	0.133	0.156	0.185	0.213	0.243	0.276	0.31	0.354	0.394	0.437	0.481		

# AIRFLOW DATA FOR CAPT, CAPTA

## AIR QUANTITY (SCFM) VS. PRESSURE DROP (IN. WC)

	SCFM	1000	1100	1200	1300	1400	1500	1600	1700	1800	1900	2000	2100	2200
<b>CAPT4961C4*</b>	Wet	0.209	0.233	0.255	0.286	0.308	0.341	0.397	0.412	0.455	0.496	0.540	0.628	0.643
	Dry	0.202	0.219	0.236	0.248	0.288	0.300	0.306	0.315	0.332	0.351	0.406	0.431	0.604
<b>CAPT4961D4*</b>	Wet	0.140	0.158	0.179	0.198	0.228	0.249	0.277	0.300	0.329	0.351	0.397	0.462	0.487
	Dry	0.128	0.140	0.159	0.178	0.189	0.202	0.206	0.212	0.232	0.252	0.282	0.302	0.419
	<b>SCFM</b>	<b>1000</b>	<b>1100</b>	<b>1200</b>	<b>1300</b>	<b>1400</b>	<b>1500</b>	<b>1600</b>	<b>1700</b>	<b>1800</b>	<b>1900</b>	<b>2000</b>	<b>2100</b>	<b>2200</b>
<b>CAPT4961C4*</b>	Wet	0.209	0.233	0.255	0.286	0.308	0.341	0.397	0.412	0.455	0.496	0.540	0.628	0.643
	Dry	0.202	0.219	0.236	0.248	0.288	0.300	0.306	0.315	0.332	0.351	0.406	0.431	0.604
<b>CAPT4961D4*</b>	Wet	0.140	0.158	0.179	0.198	0.228	0.249	0.277	0.300	0.329	0.351	0.397	0.462	0.487
	Dry	0.128	0.140	0.159	0.178	0.189	0.202	0.206	0.212	0.232	0.252	0.282	0.302	0.419
	<b>SCFM</b>	<b>400</b>	<b>500</b>	<b>600</b>	<b>700</b>	<b>800</b>	<b>900</b>	<b>1000</b>	<b>1100</b>	<b>1200</b>				
<b>CAPTA1818A4**</b>	Wet	0.080	0.135	0.205	0.275	0.346	0.422	0.516	0.620	0.715				
	Dry	0.074	0.115	0.180	0.239	0.297	0.368	0.443	0.543	0.638				
<b>CAPTA1818B4**</b>	Wet	0.067	0.106	0.165	0.215	0.261	0.317	0.372	0.425	0.482				
	Dry	0.050	0.087	0.125	0.175	0.215	0.265	0.319	0.381	0.444				
	<b>SCFM</b>	<b>500</b>	<b>600</b>	<b>700</b>	<b>800</b>	<b>900</b>	<b>1000</b>	<b>1100</b>	<b>1200</b>	<b>1300</b>				
<b>CAPTA2422A4**</b>	Wet	0.108	0.150	0.195	0.250	0.310	0.379	0.460	0.543	0.625				
	Dry	0.088	0.125	0.170	0.215	0.265	0.320	0.385	0.440	0.535				
<b>CAPTA2422B4**</b>	Wet	0.090	0.130	0.150	0.220	0.250	0.310	0.369	0.436	0.508				
	Dry	0.082	0.100	0.140	0.170	0.210	0.260	0.300	0.350	0.410				
<b>CAPTA2422C4**</b>	Wet	0.091	0.110	0.139	0.172	0.205	0.245	0.285	0.335	0.387				
	Dry	0.069	0.084	0.111	0.133	0.162	0.185	0.210	0.250	0.295				

## AIRFLOW DATA FOR CAPTA (CONT.)

AIR QUANTITY (SCFM) VS. PRESSURE DROP (IN. WC)

	SCFM	600	700	800	900	1000	1100	1200	1300	1400	1500	1600	1700	1800	1900
<b>CAPTA3022A4**</b>	Wet	0.150	0.195	0.250	0.310	0.379	0.460	0.543	0.625	0.730					
	Dry	0.125	0.170	0.215	0.265	0.320	0.385	0.440	0.535	0.618					
<b>CAPTA3022B4**</b>	Wet	0.130	0.150	0.220	0.250	0.310	0.369	0.436	0.508	0.584					
	Dry	0.100	0.140	0.170	0.210	0.260	0.300	0.350	0.410	0.480					
<b>CAPTA3022C4**</b>	Wet	0.110	0.139	0.172	0.205	0.245	0.285	0.335	0.387	0.437					
	Dry	0.084	0.111	0.133	0.162	0.185	0.210	0.250	0.295	0.330					
<b>CAPTA3026B4**</b>	Wet	0.115	0.150	0.190	0.229	0.270	0.310	0.365	0.420	0.475					
	Dry	0.096	0.122	0.150	0.183	0.215	0.252	0.292	0.334	0.382					
<b>CAPTA3026C4**</b>	Wet	0.090	0.110	0.140	0.170	0.200	0.240	0.280	0.320	0.370					
	Dry	0.080	0.100	0.120	0.150	0.180	0.210	0.240	0.260	0.300					
<b>CAPTA3626B4**</b>	Wet	0.134	0.167	0.204	0.245	0.290	0.338	0.389	0.444	0.485					
	Dry	0.127	0.157	0.190	0.229	0.269	0.316	0.360	0.415	0.450					
<b>CAPTA3626C4**</b>	Wet	0.100	0.120	0.150	0.180	0.210	0.240	0.280	0.310	0.360					
	Dry	0.080	0.100	0.130	0.150	0.170	0.200	0.230	0.270	0.300					
<b>CAPTA4230C4**</b>	Wet	0.130	0.150	0.180	0.210	0.250	0.280	0.310	0.340	0.378					
	Dry	0.110	0.132	0.156	0.181	0.208	0.237	0.270	0.300	0.335					
<b>CAPTA4230D4**</b>	Wet	0.120	0.140	0.160	0.190	0.220	0.250	0.280	0.310	0.350					
	Dry	0.091	0.109	0.127	0.147	0.160	0.190	0.210	0.230	0.260					

## AIRFLOW DATA FOR CHPTA AND CHPT

AIR QUANTITY (SCFM) VS. PRESSURE DROP (IN. WC)

	SCFM	400	500	600	700	800	900	1000	1100	1200	1300	1400	1500	1600	1700	1800	1900	2000	2100	2200	
<b>CHPTA1822A4**</b>	Wet	0.095	0.151	0.215	0.284	0.354	0.429	0.519	0.601												
	Dry	0.064	0.094	0.144	0.199	0.284	0.353	0.431	0.513												
<b>CHPTA1822B4**</b>	Wet	0.090	0.120	0.140	0.190	0.250	0.310	0.390	0.460												
	Dry	0.080	0.110	0.130	0.180	0.230	0.290	0.360	0.430												
<b>CHPTA2426B4**</b>	Wet	0.13	0.150	0.180	0.204	0.255	0.304	0.365	0.419	0.468											
	Dry	0.10	0.120	0.150	0.170	0.210	0.240	0.290	0.330	0.410											
<b>CHPTA2426C4**</b>	Wet	0.11	0.140	0.160	0.180	0.200	0.230	0.270	0.320	0.370											
	Dry	0.09	0.110	0.130	0.150	0.190	0.220	0.260	0.300	0.350											
<b>CHPTA3026B4**</b>	Wet	0.11	0.150	0.180	0.230	0.280	0.320	0.370	0.430	0.490											
	Dry	0.12	0.140	0.170	0.210	0.250	0.290	0.340	0.400	0.460											
<b>CHPTA3026C4**</b>	Wet	0.1	0.130	0.150	0.170	0.200	0.230	0.260	0.300	0.340											
	Dry	0.06	0.080	0.110	0.130	0.150	0.174	0.198	0.229	0.259											
<b>CHPTA3630B4**</b>	Wet	0.15	0.187	0.229	0.279	0.323	0.372	0.43	0.465												
	Dry	0.128	0.153	0.191	0.237	0.285	0.33	0.377	0.428												
<b>CHPTA3630C4**</b>	Wet	0.14	0.175	0.205	0.245	0.285	0.325	0.365	0.41												
	Dry	0.086	0.105	0.135	0.155	0.185	0.21	0.245	0.279												
<b>CHPT4860D4**</b>	Wet	0.126	0.150	0.175	0.200	0.230	0.265	0.295	0.325	0.355	0.395	0.433	0.449	0.467							
	Dry	0.12	0.137	0.164	0.186	0.215	0.246	0.278	0.315	0.341	0.379	0.409	0.472	0.514							

## AIRFLOW DATA FOR CHPF AND CHPE

AIR QUANTITY (SCFM) VS. PRESSURE DROP (IN. WC)

	SCFM	600	700	800	900	1000	1100	1200	1300	1400	1500	1600				
<b>CHPF3636B6*</b>	Wet	0.107	0.131	0.167	0.199	0.239	0.291	0.338	0.389	0.439	0.494	0.552				
<b>CHPE3636B4*</b>	Dry	0.102	0.126	0.152	0.184	0.220	0.259	0.303	0.349	0.401	0.458	0.516				
	SCFM	800	900	1000	1100	1200	1300	1400	1500	1600	1700	1800	1900	2000	2100	2200
<b>CHPF3642C6*</b>	Wet	0.083	0.103	0.126	0.151	0.178	0.208	0.240	0.274	0.310	0.346	0.383	---	---	---	---
<b>CHPE3642C4*</b>	Dry	0.073	0.096	0.120	0.144	0.169	0.196	0.224	0.254	0.286	0.319	0.354	---	---	---	---
<b>CHPF3642D6*</b>	Wet	0.040	0.050	0.060	0.070	0.080	0.080	0.090	0.100	0.110	0.120	0.120	0.130	0.150	0.160	0.180
	Dry	0.030	0.040	0.040	0.050	0.060	0.070	0.080	0.085	0.090	0.100	0.110	0.120	0.140	0.150	0.160
	SCFM	800	900	1000	1100	1200	1300	1400	1500	1600	1700	1800	1900	2000	2100	2200
<b>CHPF3743C6*</b>	Wet	0.133	0.153	0.176	0.201	0.228	0.258	0.290	0.324	0.360	0.396	0.433	---	---	---	---
<b>CHPE3743C4*</b>	Dry	0.123	0.146	0.170	0.194	0.219	0.246	0.274	0.304	0.336	0.369	0.404	---	---	---	---
<b>CHPE3743D4*</b>	Wet	0.101	0.105	0.115	0.125	0.145	0.165	0.195	0.215	0.235	0.265	0.295	0.315	0.355	0.375	0.405
	Dry	0.072	0.095	0.105	0.115	0.135	0.155	0.185	0.205	0.225	0.255	0.275	0.305	0.335	0.365	0.395
	SCFM	900	1000	1100	1200	1300	1400	1500	1600	1700	1800	1900	2000	2100	2200	
<b>CHPF4860D6*</b>	Wet	0.111	0.131	0.151	0.171	0.191	0.211	0.231	0.261	0.291	0.321	0.361	0.391	0.431	0.471	
<b>CHPE4860D4*</b>	Dry	0.101	0.121	0.141	0.161	0.181	0.201	0.221	0.251	0.281	0.311	0.341	0.371	0.411	0.441	

## AIRFLOW DATA FOR CSCF

AIR QUANTITY (SCFM) VS. PRESSURE DROP (IN. WC)

	SCFM	500	600	700	800	900	1000	1100	1200										
<b>CSCF1824N6D*</b>	Wet	0.104	0.143	0.176	0.212	0.255	0.292	0.321	0.344										
	Dry	0.048	0.067	0.086	0.108	0.132	0.159	0.186	0.206										
	SCFM			700	800	900	1000	1100	1200	1300	1400								
<b>CSCF3036N6D*</b>	Wet	---	---	0.062	0.076	0.092	0.109	0.131	0.156	0.186	0.209								
	Dry	---	---	0.032	0.043	0.055	0.068	0.082	0.099	0.114	0.131								
	SCFM				800	900	1000	1100	1200	1300	1400	1500	1600	1700	1800	1900	2000	2100	2200
<b>CSCF3642N6D*</b>	Wet	---	---	---	0.045	0.063	0.081	0.099	0.116	0.132	0.148	0.166	0.183	0.202	0.220	0.236	0.259	0.278	0.291
	Dry	---	---	---	0.039	0.051	0.064	0.077	0.092	0.105	0.121	0.138	0.150	0.175	0.191	0.214	0.230	0.251	0.262
	SCFM				800	900	1000	1100	1200	1300	1400	1500	1600	1700	1800	1900	2000	2100	2200
<b>CSCF4860N6D*</b>	Wet	---	---	---	0.051	0.068	0.085	0.103	0.120	0.137	0.154	0.173	0.192	0.212	0.233	0.255	0.278	0.299	0.319
	Dry	---	---	---	0.043	0.056	0.069	0.084	0.099	0.115	0.132	0.149	0.167	0.185	0.207	0.227	0.249	0.272	.282**

\*\* Maximum SCFM = 2146

## ACCESSORIES

### EXPANSION VALVE KITS FOR NON-TXV, NON-EEV COILS

KIT NUMBER	DESCRIPTION	APPLICATION	REFRIGERANT	TONNAGE: OUTDOOR UNIT
TXV-30 <sup>2</sup>	Non-bleed Valve	AC Only	R-410A	1½ - 2½ Ton
TXV-42 <sup>2</sup>	Non-bleed Valve	AC Only	R-410A	3 - 3½ Ton
TXV-48 <sup>2</sup>	Non-bleed Valve	AC Only	R-410A	4 Ton
TXV-60 <sup>2</sup>	Non-bleed Valve	AC Only	R-410A	5 Ton
TX2N4A	Non-bleed Valve	AC or HP	R-410A	1½ - 2 Ton
TX3N4	Non-bleed Valve	AC or HP	R-410A	2½ - 3 Ton
TX5N4	Non-bleed Valve	AC or HP	R-410A	3½ - 5 Ton

**Note:** Condensing units and heat pumps with reciprocating compressors require the use of start-assist components when used in conjunction with an indoor coil using a non-bleed thermal expansion valve refrigerant metering device.

### HIGH-TEMP DRAIN PAN KITS FOR CAUF, CAPF AND CAPT

DRAIN PAN KITS	FURNACE SIZE
HTP-A	14" furnaces
HTP-B	17½" furnaces
HTP-C	21" furnaces
HTP-D	24½" furnaces

### DRAIN PAN INSULATION KITS FOR CAPEA, CAPTA, CAPFA, & CAUFA

KIT NUMBER	CABINET WIDTH
DPICX-AB	14"
DPICX-BB	17½"
DPICX-CB	21"
DPICX-DB	24½"

### DRAIN PAN INSULATION KITS FOR CAPE

KIT NUMBER	CABINET WIDTH
(a) DPICX-C (b) DPICX-CA	21"
(a) DPICX-D (b) DPICX-DA	24½"

\* (a) and (b) are compatible.  
(a) being used to depletion (a) by replaced (b).

### DOWNFLOW KIT FOR CAPE

KIT NUMBER	CABINET WIDTH
DFKE-001	21" , 24½"

### HORIZONTAL RIGHT COIL ACCESSORY FOR HIGH HUMIDITY ENVIRONMENT FOR CHPTA

KIT NUMBER	CABINET WIDTH
HHCMK01	All Horizontal cabinets

### HIGH-TEMP DRAIN PAN KITS FOR CAUFA, CAPFA, CAPTA AND CAPEA

DRAIN PAN KITS	FURNACE SIZE
HTP7-A	14" Furnaces
HTP7-B	17½" furnaces
HTP7-C	21" furnace
HTP7-D	24½" furnaces

