

ENERGY-EFFICIENT
R-32 SPLIT SYSTEM AIR CONDITIONER
UP TO 15.2 SEER2
1½ TO 5 TONS

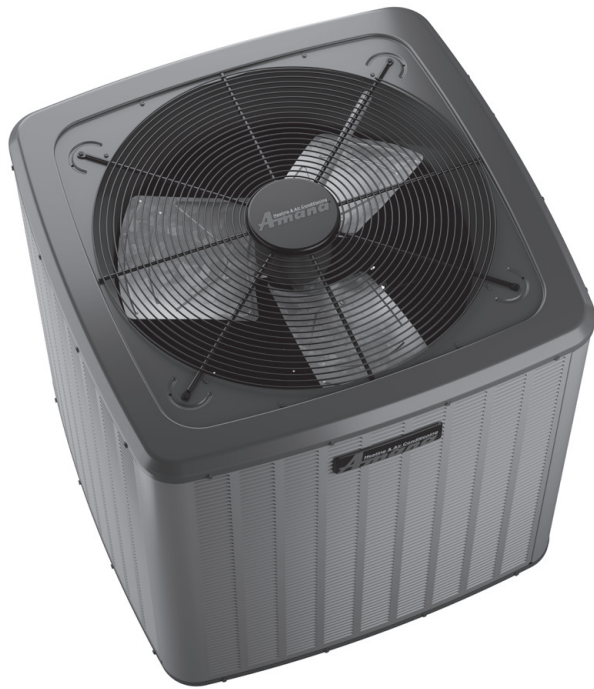

Contents

Nomenclature 2
 Product Specifications 3
 Expanded Cooling Data 4
 Performance Data 18
 Wiring Diagrams 20
 Dimensions 23
 Accessories 23

R32

Standard Features

- Energy-efficient compressor
- Copper tube/ enhanced aluminum fin coil- 5mm diameter
- Factory-installed filter drier
- Sweat connection service valves with easy access to gauge ports
- Enclosed contactor
- High-pressure switch
- Ground lug connection
- Capacitors with extended life
- AHRI Certified
- ETL Listed

Cabinet Features

- Removable grille-style top design compliant with UL 60335-2-40
- Venturi for increased velocity of airflow
- Attractive Architectural Gray powder-paint finish with 500-hour salt-spray approval
- Wire fan discharge grille
- Steel louver coil guard
- Compact footprint
- Top and side maintenance access
- Single-panel access to controls with space provided for field-installed accessories
- When properly anchored, meets the 2023 Florida Building Code unit integrity requirements for hurricane-type winds (Anchor bracket kits available.)



COMPANY WITH
 QUALITY SYSTEM
 CERTIFIED BY DNV GL
 = ISO 9001 =

COMPANY WITH
 ENVIRONMENTAL SYSTEM
 CERTIFIED BY DNV GL
 = ISO 14001 =

* Complete warranty details available from your local dealer or at www.amana-hac.com. To receive the 10-Year Parts Limited Warranty, online registration must be completed within 60 days of installation. Online registration is not required in California or Québec. The duration of warranty coverages in Texas differs in some cases.

NOMENCLATURE

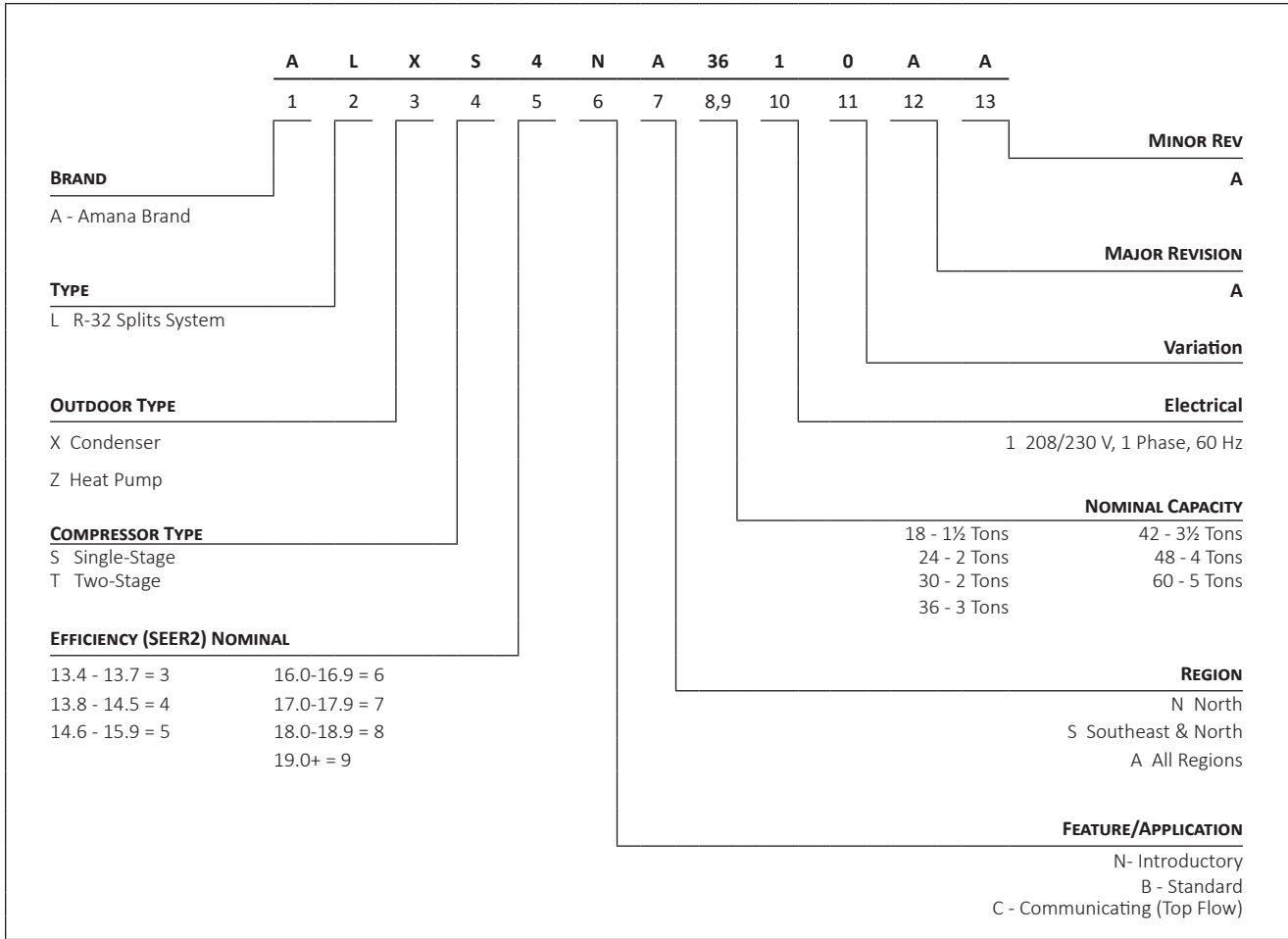

	ALXS4N A1810A*	ALXS4N A2410A*	ALXS4N A3010A*	ALXS4N A3610A*	ALXS4N A4210A*	ALXS4N A4810A*	ALXS4N A6010A*
COOLING CAPACITY							
Nominal Cooling (BTU/h)	18,000	24,000	30,000	36,000	42,000	48,000	60,000
Decibels (dBA)	74.0	74.0	71.0	67.0	72.0	73.0	76.0
COMPRESSOR							
RLA	8.2	8.2	11.2	13.4	14.4	19.4	23.9
LRA	41.2	41.2	52.5	83.3	112.2	127.7	148.0
Stage	Single	Single	Single	Single	Single	Single	Single
Type	Rotary	Rotary	Rotary	Scroll	Scroll	Scroll	Scroll
CONDENSER FAN MOTOR							
Motor Type	PSC	PSC	PSC	PSC	PSC	PSC	ECM
Horsepower (RPM)	1/8	1/8	1/6	1/6	1/6	1/6	1/3
FLA	0.70	0.70	0.95	0.95	0.95	0.95	2.6
REFRIGERATION SYSTEM							
Refrigerant Line Size ¹							
Liquid Line Size ("O.D.)	3/8"	3/8"	3/8"	3/8"	3/8"	3/8"	3/8"
Suction Line Size ("O.D.)	3/4"	3/4"	3/4"	7/8"	1 1/8"	1 1/8"	1 1/8"
Refrigerant Connection Size							
Liquid Valve Size ("O.D.)	3/8"	3/8"	3/8"	3/8"	3/8"	3/8"	3/8"
Suction Valve Size ("O.D.) ²	3/4"	3/4"	3/4"	7/8"	7/8"	7/8"	7/8"
Valve Connection Type	Sweat	Sweat	Sweat	Sweat	Sweat	Sweat	Sweat
Refrigerant Charge ³	53	53	63	69	83	91	94
ELECTRICAL DATA							
Voltage-Phase	208/230-1	208/230-1	208/230-1	208/230-1	208/230-1	208/230-1	208/230-1
Minimum Circuit Ampacity ⁴	10.9	10.9	15.0	17.8	19.0	25.2	32.4
Max. Overcurrent Protection ⁵	15.0	15.0	25.0	30.0	30.0	40.0	50.0
Min / Max Volts	197/253	197/253	197/253	197/253	197/253	197/253	197/253
Electrical Conduit Size	1/2" or 3/4"	1/2" or 3/4"	1/2" or 3/4"	1/2" or 3/4"	1/2" or 3/4"	1/2" or 3/4"	1/2" or 3/4"
Equipment Weight (lbs)	117	117	155	158	210	211	224
Ship Weight (lbs)	132	132	170	173	225	226	239

¹ Line sizes denoted for 25' line sets, tested and rated in accordance with AHRI Standard 210/240. For other line set lengths or sizes, refer to the Installation Instructions and/or the Long Line Set Applications guide.

² Any suction line adapter will need to be supplied by the field.

³ Unit is factory charged with refrigerant for 15' of 3/8" liquid line. System charge must be adjusted per the Final Charge Adjustment procedure found in the Installation Instructions.

⁴ Wire size should be determined in accordance with National Electrical Codes; extensive wire runs will require larger wire sizes

⁵ Must use time-delay fuses or HACR-type circuit breakers of the same size as noted.

NOTES

- Always check the S&R plate for electrical data on the unit being installed.

EXPANDED COOLING DATA — ALXS4NA1810A*+ CAPTA2422A*

IDB		OUTDOOR AMBIENT TEMPERATURE																							
		65				75				85				95				105				115			
		59	63	67	71	59	63	67	71	59	63	67	71	59	63	67	71	59	63	67	71	59	63	67	71
AIRFLOW		59	63	67	71	59	63	67	71	59	63	67	71	59	63	67	71	59	63	67	71	59	63	67	71
		17.8	18.1	18.6	-	17.7	17.9	18.5	-	17.2	17.5	18.0	-	16.4	16.7	17.2	-	15.4	15.7	16.2	-	14.5	14.8	15.3	-
525		0.53	0.46	0.34	-	0.54	0.47	0.34	-	0.56	0.49	0.37	-	0.58	0.51	0.38	-	0.60	0.53	0.40	-	0.64	0.57	0.45	-
		23	21	17	-	23	21	17	-	24	22	18	-	23	21	17	-	23	21	17	-	24	22	18	-
kW		1.12	1.12	1.12	-	1.24	1.24	1.23	-	1.37	1.37	1.37	-	1.51	1.51	1.51	-	1.67	1.67	1.67	-	1.85	1.85	1.85	-
Amps		3.9	3.9	3.9	-	4.4	4.4	4.4	-	5.0	5.0	5.0	-	5.7	5.7	5.7	-	6.4	6.4	6.4	-	7.2	7.2	7.2	-
		18.1	18.4	18.9	-	18.0	18.2	18.8	-	17.5	17.8	18.3	-	16.7	17.0	17.5	-	15.7	16.0	16.5	-	14.8	15.1	15.6	-
625		0.61	0.54	0.41	-	0.61	0.54	0.42	-	0.63	0.56	0.44	-	0.65	0.58	0.46	-	0.67	0.60	0.48	-	0.72	0.65	0.53	-
		22	20	16	-	22	20	16	-	22	20	16	-	22	20	16	-	21	19	15	-	23	21	17	-
kW		1.13	1.13	1.13	-	1.25	1.24	1.24	-	1.38	1.38	1.37	-	1.52	1.52	1.51	-	1.68	1.68	1.67	-	1.86	1.86	1.86	-
Amps		3.9	3.9	3.9	-	4.5	4.5	4.4	-	5.1	5.1	5.0	-	5.7	5.7	5.7	-	6.4	6.4	6.4	-	7.3	7.3	7.3	-
		18.3	18.6	19.1	-	18.2	18.4	18.9	-	17.7	17.9	18.5	-	16.9	17.1	17.7	-	15.9	16.2	16.7	-	15.0	15.3	15.8	-
675		0.63	0.56	0.44	-	0.63	0.56	0.44	-	0.66	0.59	0.46	-	0.67	0.60	0.48	-	0.69	0.62	0.50	-	0.74	0.67	0.55	-
		21	19	15	-	21	19	15	-	21	19	15	-	21	19	15	-	21	19	15	-	22	20	16	-
kW		1.13	1.13	1.13	-	1.25	1.25	1.25	-	1.38	1.38	1.38	-	1.52	1.52	1.52	-	1.68	1.68	1.68	-	1.86	1.86	1.86	-
Amps		3.9	3.9	3.9	-	4.5	4.5	4.5	-	5.1	5.1	5.1	-	5.7	5.7	5.7	-	6.4	6.4	6.4	-	7.3	7.3	7.3	-

IDB		OUTDOOR AMBIENT TEMPERATURE																							
		65				75				85				95				105				115			
		59	63	67	71	59	63	67	71	59	63	67	71	59	63	67	71	59	63	67	71	59	63	67	71
AIRFLOW		59	63	67	71	59	63	67	71	59	63	67	71	59	63	67	71	59	63	67	71	59	63	67	71
		17.9	18.1	18.6	19.5	17.7	18.0	18.5	19.3	17.2	17.5	18.0	18.8	16.4	16.7	17.2	18.0	15.4	15.7	16.2	17.0	14.5	14.8	15.3	16.1
525		0.65	0.58	0.46	0.3	0.65	0.58	0.46	0.3	0.68	0.61	0.48	0.4	0.69	0.62	0.50	0.4	0.71	0.64	0.52	0.4	1.00	0.69	0.57	0.4
		28	26	22	18	28	26	22	18	28	26	22	18	28	26	22	18	28	26	22	18	29	27	23	19
kW		1.12	1.12	1.12	1.1	1.24	1.24	1.23	1.2	1.37	1.37	1.36	1.4	1.51	1.51	1.51	1.5	1.67	1.67	1.66	1.7	1.85	1.85	1.85	1.9
Amps		3.9	3.9	3.9	3.9	4.4	4.4	4.4	4.4	5.0	5.0	5.0	5.0	5.7	5.7	5.7	5.7	6.4	6.4	6.4	6.4	7.2	7.2	7.2	7.3
		18.2	18.4	18.9	19.8	18.0	18.2	18.8	19.6	17.5	17.8	18.3	19.1	16.7	17.0	17.5	18.3	15.7	16.0	16.5	17.3	14.8	15.1	15.6	16.4
625		0.72	0.65	0.53	0.4	0.73	0.66	0.54	0.4	0.75	0.68	0.56	0.4	0.77	0.70	0.58	0.4	1.00	0.72	0.60	0.5	1.00	0.77	0.64	0.5
		26	24	20	16	26	24	20	16	27	25	21	16	26	24	20	16	26	24	20	16	27	25	21	17
kW		1.13	1.13	1.12	1.13	1.24	1.24	1.24	1.25	1.38	1.37	1.37	1.38	1.52	1.52	1.51	1.52	1.68	1.67	1.67	1.68	1.86	1.86	1.86	1.87
Amps		3.9	3.9	3.9	3.9	4.5	4.5	4.4	4.5	5.1	5.1	5.0	5.1	5.7	5.7	5.7	5.7	6.4	6.4	6.4	6.5	7.3	7.3	7.3	7.3
		18.3	18.6	19.1	19.9	18.2	18.4	19.0	19.8	17.7	18.0	18.5	19.3	16.9	17.1	17.7	18.5	15.9	16.2	16.7	17.5	15.0	15.3	15.8	16.6
675		0.74	0.68	0.55	0.4	0.75	0.68	0.56	0.4	0.77	0.70	0.58	0.5	0.79	0.72	0.60	0.5	1.00	0.74	0.62	0.5	1.00	0.79	0.67	0.5
		26	24	20	16	26	24	20	15	26	24	20	16	26	24	20	15	25	23	19	15	27	25	21	16
kW		1.13	1.13	1.13	1.1	1.25	1.25	1.25	1.3	1.38	1.38	1.38	1.4	1.52	1.52	1.52	1.5	1.68	1.68	1.68	1.7	1.86	1.86	1.86	1.9
Amps		3.9	3.9	3.9	4.0	4.5	4.5	4.5	4.5	5.1	5.1	5.1	5.1	5.7	5.7	5.7	5.7	6.4	6.4	6.4	6.5	7.3	7.3	7.3	7.3

IDB: Entering Indoor Dry Bulb Temperature
 High and low pressures are measured at the liquid and suction service valves.
 Shaded area reflects ACCA (TVA) conditions
 kW = Total system power
 Amps = outdoor unit amps (comp.+fan)

EXPANDED COOLING DATA — ALXS4NA1810A*+ CAPTA2422A* (CONT.)

IDB	AIRFLOW	OUTDOOR AMBIENT TEMPERATURE																							
		65				75				85				95				105				115			
		59	63	67	71	59	63	67	71	59	63	67	71	59	63	67	71	59	63	67	71	59	63	67	71
80	MBh	18.0	18.2	18.7	19.6	17.8	18.0	18.6	19.4	17.3	17.6	18.1	18.9	16.5	16.8	17.3	18.1	15.5	15.8	16.3	17.1	14.6	14.9	15.4	16.2
	S/T	0.76	0.69	0.57	0.4	0.77	0.70	0.58	0.4	0.79	0.72	0.60	0.5	1.00	0.74	0.62	0.5	1.00	0.76	0.64	0.5	1.00	0.81	0.68	0.6
	ΔT	33	31	27	23	33	31	27	23	33	31	27	23	33	31	27	23	33	30	26	22	34	32	28	24
	kW	1.12	1.12	1.12	1.1	1.24	1.24	1.23	1.2	1.37	1.37	1.37	1.4	1.51	1.51	1.51	1.5	1.67	1.67	1.66	1.7	1.85	1.85	1.85	1.9
	Amps	3.9	3.9	3.9	3.9	4.4	4.4	4.4	4.4	5.0	5.0	5.0	5.0	5.7	5.7	5.7	5.7	6.4	6.4	6.4	6.4	7.2	7.2	7.2	7.3
625	MBh	18.2	18.5	19.0	19.8	18.1	18.3	18.9	19.7	17.6	17.9	18.4	19.2	16.8	17.1	17.6	18.4	15.8	16.1	16.6	17.4	14.9	15.2	15.7	16.5
	S/T	0.84	0.77	0.64	0.5	0.84	0.77	0.65	0.5	1.00	0.80	0.67	0.5	1.00	0.81	0.69	0.6	1.00	0.83	0.71	0.6	1.00	0.88	0.76	0.6
	ΔT	31	29	25	21	31	29	25	21	31	29	25	21	31	29	25	21	31	29	25	21	32	30	26	22
	kW	1.13	1.13	1.13	1.13	1.25	1.24	1.24	1.25	1.38	1.38	1.37	1.38	1.52	1.52	1.51	1.52	1.68	1.67	1.67	1.68	1.86	1.86	1.86	1.87
	Amps	3.9	3.9	3.9	4.0	4.5	4.5	4.4	4.5	5.1	5.1	5.0	5.1	5.7	5.7	5.7	5.7	6.4	6.4	6.4	6.5	7.3	7.3	7.3	7.3
675	MBh	18.4	18.7	19.2	20.0	18.3	18.5	19.0	19.9	17.8	18.0	18.6	19.4	17.0	17.2	17.8	18.6	16.0	16.3	16.8	17.6	15.1	15.4	15.9	16.7
	S/T	0.86	0.79	0.67	0.5	0.86	0.80	0.67	0.5	1.00	0.82	0.69	0.6	1.00	0.84	0.71	0.6	1.00	0.86	0.73	0.6	1.00	0.90	0.78	0.6
	ΔT	30	28	24	20	30	28	24	20	31	29	25	20	30	28	24	20	30	28	24	20	31	29	25	21
	kW	1.13	1.13	1.13	1.1	1.25	1.25	1.25	1.3	1.38	1.38	1.38	1.4	1.52	1.52	1.52	1.5	1.68	1.68	1.68	1.7	1.86	1.86	1.86	1.9
	Amps	3.9	3.9	3.9	4.0	4.5	4.5	4.5	4.5	5.1	5.1	5.1	5.1	5.7	5.7	5.7	5.7	6.4	6.4	6.4	6.5	7.3	7.3	7.3	7.3

IDB	AIRFLOW	OUTDOOR AMBIENT TEMPERATURE																							
		65				75				85				95				105				115			
		59	63	67	71	59	63	67	71	59	63	67	71	59	63	67	71	59	63	67	71	59	63	67	71
85	MBh	18.3	18.5	19.0	19.9	18.1	18.3	18.9	19.7	17.6	17.9	18.4	19.2	16.8	17.1	17.6	18.4	15.8	16.1	16.6	17.4	14.9	15.2	15.7	16.5
	S/T	1.00	0.78	0.66	0.5	1.00	0.79	0.67	0.5	1.00	0.81	0.69	0.6	1.00	0.83	0.71	0.6	1.00	0.85	0.73	0.6	1.00	1.00	0.77	0.6
	ΔT	37	35	31	27	37	35	31	27	37	35	31	27	37	35	31	27	37	35	31	26	38	36	32	28
	kW	1.12	1.12	1.12	1.1	1.24	1.24	1.24	1.2	1.37	1.37	1.37	1.4	1.51	1.51	1.51	1.5	1.67	1.67	1.67	1.7	1.86	1.85	1.85	1.9
	Amps	3.9	3.9	3.9	3.9	4.4	4.4	4.4	4.5	5.0	5.0	5.0	5.1	5.7	5.7	5.7	5.7	6.4	6.4	6.4	6.4	7.3	7.2	7.2	7.3
625	MBh	18.5	18.8	19.3	20.2	18.4	18.6	19.2	20.0	17.9	18.2	18.7	19.5	17.1	17.4	17.9	18.7	16.1	16.4	16.9	17.7	15.2	15.5	16.0	16.8
	S/T	1.00	0.86	0.74	0.6	1.00	0.87	0.74	0.6	1.00	0.89	0.76	0.6	1.00	0.91	0.78	0.7	1.00	1.00	0.80	0.7	1.00	1.00	0.85	0.7
	ΔT	35	33	29	25	35	33	29	25	36	34	30	25	35	33	29	25	35	33	29	25	36	34	30	26
	kW	1.13	1.13	1.13	1.14	1.25	1.25	1.24	1.25	1.38	1.38	1.38	1.38	1.52	1.52	1.52	1.53	1.68	1.68	1.68	1.68	1.86	1.86	1.86	1.87
	Amps	3.9	3.9	3.9	4.0	4.5	4.5	4.5	4.5	5.1	5.1	5.1	5.1	5.7	5.7	5.7	5.7	6.4	6.4	6.4	6.5	7.3	7.3	7.3	7.3
675	MBh	18.7	19.0	19.5	20.3	18.6	18.8	19.3	20.2	18.1	18.3	18.9	19.7	17.3	17.5	18.1	18.9	16.3	16.6	17.1	17.9	15.4	15.7	16.2	17.0
	S/T	1.00	0.88	0.76	0.6	1.00	0.89	0.76	0.6	1.00	0.91	0.79	0.7	1.00	0.93	0.80	0.7	1.00	1.00	0.82	0.7	1.00	1.00	0.87	0.7
	ΔT	35	33	29	24	35	32	29	24	35	33	29	25	35	32	28	24	34	32	28	24	36	34	30	25
	kW	1.13	1.13	1.13	1.1	1.25	1.25	1.25	1.3	1.38	1.38	1.38	1.4	1.52	1.52	1.52	1.5	1.68	1.68	1.68	1.7	1.87	1.87	1.86	1.9
	Amps	3.9	3.9	3.9	4.0	4.5	4.5	4.5	4.5	5.1	5.1	5.1	5.1	5.7	5.7	5.7	5.8	6.5	6.5	6.4	6.5	7.3	7.3	7.3	7.3

IDB: Entering Indoor Dry Bulb Temperature
 High and low pressures are measured at the liquid and suction service valves.
 Shaded area reflects AHRI conditions
 kW = Total system power
 Amps = outdoor unit amps (comp.+fan)

EXPANDED COOLING DATA — ALXS4NA2410A*+ CAPTA2422A*

IDB		OUTDOOR AMBIENT TEMPERATURE																							
		65				75				85				95				105				115			
		AIRFLOW	59	63	67	71	59	63	67	71	59	63	67	71	59	63	67	71	59	63	67	71	59	63	67
700	MBh	24.3	24.7	25.4	-	24.1	24.4	25.2	-	23.5	23.8	24.5	-	22.4	22.7	23.5	-	21.1	21.4	22.1	-	19.9	20.2	20.9	-
	S/T	0.63	0.56	0.43	-	0.64	0.57	0.44	-	0.66	0.59	0.46	-	0.68	0.61	0.48	-	0.70	0.63	0.50	-	0.75	0.68	0.55	-
	ΔT	21	19	15	-	21	19	15	-	21	19	15	-	21	19	15	-	20	18	15	-	22	20	16	-
	kW	1.48	1.48	1.47	-	1.65	1.64	1.64	-	1.83	1.83	1.83	-	2.04	2.04	2.03	-	2.26	2.26	2.26	-	2.53	2.53	2.53	-
	Amps	5.3	5.3	5.3	-	6.1	6.1	6.1	-	7.0	7.0	7.0	-	7.9	7.9	7.9	-	8.9	8.9	8.9	-	10.2	10.2	10.1	-
800	MBh	24.8	25.1	25.8	-	24.5	24.9	25.6	-	23.9	24.3	25.0	-	22.8	23.2	23.9	-	21.5	21.9	22.6	-	20.3	20.7	21.4	-
	S/T	0.67	0.59	0.47	-	0.67	0.60	0.47	-	0.70	0.62	0.50	-	0.71	0.64	0.51	-	0.74	0.66	0.53	-	1.00	0.71	0.58	-
	ΔT	20	18	14	-	20	17	14	-	20	18	14	-	20	17	14	-	19	17	13	-	21	18	15	-
	kW	1.49	1.48	1.48	-	1.65	1.65	1.65	-	1.84	1.84	1.84	-	2.04	2.04	2.04	-	2.27	2.27	2.27	-	2.54	2.54	2.53	-
	Amps	5.4	5.4	5.4	-	6.2	6.2	6.1	-	7.0	7.0	7.0	-	7.9	7.9	7.9	-	9.0	9.0	9.0	-	10.2	10.2	10.2	-
900	MBh	25.3	25.6	26.4	-	25.1	25.4	26.1	-	24.5	24.8	25.5	-	23.4	23.7	24.4	-	22.1	22.4	23.1	-	20.9	21.2	21.9	-
	S/T	0.67	0.60	0.47	-	0.68	0.61	0.48	-	0.70	0.63	0.50	-	0.72	0.65	0.52	-	0.74	0.67	0.54	-	1.00	0.72	0.59	-
	ΔT	19	17	13	-	18	16	13	-	19	17	13	-	18	16	13	-	18	16	12	-	19	17	14	-
	kW	1.49	1.49	1.49	-	1.66	1.66	1.66	-	1.85	1.85	1.84	-	2.05	2.05	2.05	-	2.28	2.28	2.27	-	2.55	2.54	2.54	-
	Amps	5.4	5.4	5.4	-	6.2	6.2	6.2	-	7.0	7.0	7.0	-	8.0	8.0	8.0	-	9.0	9.0	9.0	-	10.2	10.2	10.2	-

IDB		OUTDOOR AMBIENT TEMPERATURE																							
		65				75				85				95				105				115			
		AIRFLOW	59	63	67	71	59	63	67	71	59	63	67	71	59	63	67	71	59	63	67	71	59	63	67
700	MBh	24.3	24.7	25.4	26.5	24.1	24.5	25.2	26.3	23.5	23.8	24.6	25.6	22.4	22.8	23.5	24.6	21.1	21.4	22.2	23.3	19.9	20.2	21.0	22.0
	S/T	0.75	0.68	0.55	0.4	0.76	0.69	0.56	0.4	0.78	0.71	0.58	0.4	0.80	0.73	0.60	0.5	1.00	0.75	0.62	0.5	1.00	0.80	0.67	0.5
	ΔT	25	23	19	15	25	23	19	15	25	23	20	16	25	23	19	15	25	23	19	15	26	24	20	16
	kW	1.48	1.48	1.47	1.5	1.64	1.64	1.64	1.7	1.83	1.83	1.83	1.8	2.04	2.03	2.03	2.0	2.26	2.26	2.26	2.3	2.53	2.53	2.52	2.5
	Amps	5.3	5.3	5.3	5.4	6.1	6.1	6.1	6.2	7.0	7.0	7.0	7.0	7.9	7.9	7.9	7.9	8.9	8.9	8.9	9.0	10.2	10.2	10.1	10.2
800	MBh	24.8	25.1	25.8	26.9	24.6	24.9	25.6	26.7	23.9	24.3	25.0	26.1	22.9	23.2	23.9	25.0	21.5	21.9	22.6	23.7	20.3	20.7	21.4	22.5
	S/T	0.79	0.72	0.59	0.5	0.79	0.72	0.59	0.5	0.82	0.75	0.62	0.5	1.00	0.76	0.64	0.5	1.00	0.79	0.66	0.5	1.00	0.83	0.71	0.6
	ΔT	24	22	18	14	24	22	18	14	24	22	18	15	24	22	18	14	24	22	18	14	25	23	19	15
	kW	1.48	1.48	1.48	1.49	1.65	1.65	1.65	1.66	1.84	1.84	1.84	1.85	2.04	2.04	2.04	2.05	2.27	2.27	2.27	2.28	2.54	2.54	2.53	2.55
	Amps	5.4	5.4	5.4	5.4	6.2	6.1	6.1	6.2	7.0	7.0	7.0	7.0	7.9	7.9	7.9	8.0	9.0	9.0	9.0	9.0	10.2	10.2	10.2	10.2
900	MBh	25.3	25.7	26.4	27.5	25.1	25.4	26.2	27.3	24.5	24.8	25.5	26.6	23.4	23.7	24.5	25.6	22.1	22.4	23.1	24.2	20.9	21.2	21.9	23.0
	S/T	0.80	0.72	0.60	0.5	0.80	0.73	0.60	0.5	0.83	0.75	0.63	0.5	1.00	0.77	0.64	0.5	1.00	0.79	0.66	0.5	1.00	0.84	0.71	0.6
	ΔT	23	21	17	13	23	21	17	13	23	21	17	13	23	21	17	13	23	21	17	13	24	22	18	14
	kW	1.49	1.49	1.49	1.5	1.66	1.66	1.66	1.7	1.85	1.85	1.84	1.9	2.05	2.05	2.05	2.1	2.28	2.28	2.27	2.3	2.54	2.54	2.54	2.6
	Amps	5.4	5.4	5.4	5.5	6.2	6.2	6.2	6.2	7.0	7.0	7.0	7.1	8.0	8.0	8.0	8.0	9.0	9.0	9.0	9.1	10.2	10.2	10.2	10.3

IDB: Entering Indoor Dry Bulb Temperature
 High and low pressures are measured at the liquid and suction service valves.
 Shaded area reflects ACCA (TVA) conditions
 kW = Total system power
 Amps = outdoor unit amps (comp.+fan)

EXPANDED COOLING DATA — ALXS4NA2410A*+ CAPTA2422A* (CONT.)

IDB		OUTDOOR AMBIENT TEMPERATURE																							
		65				75				85				95				105				115			
		AIRFLOW	59	63	67	71	59	63	67	71	59	63	67	71	59	63	67	71	59	63	67	71	59	63	67
700	MBh	24.5	24.8	25.5	26.6	24.2	24.6	25.3	26.4	23.6	24.0	24.7	25.8	22.5	22.9	23.6	24.7	21.2	21.6	22.3	23.4	20.0	20.4	21.1	22.2
	S/T	0.87	0.80	0.67	0.5	0.88	0.81	0.68	0.5	1.00	0.83	0.70	0.6	1.00	0.85	0.72	0.6	1.00	0.87	0.74	0.6	1.00	0.92	0.79	0.7
	ΔT	30	28	24	20	30	28	24	20	30	28	24	20	30	28	24	20	29	27	24	20	31	29	25	21
	kW	1.48	1.48	1.47	1.5	1.65	1.64	1.64	1.7	1.83	1.83	1.83	1.8	2.04	2.04	2.03	2.0	2.26	2.26	2.26	2.3	2.53	2.53	2.53	2.5
	Amps	5.3	5.3	5.3	5.4	6.1	6.1	6.1	6.2	7.0	7.0	7.0	7.0	7.9	7.9	7.9	7.9	8.9	8.9	8.9	9.0	10.2	10.2	10.2	10.2
800	MBh	24.9	25.2	26.0	27.1	24.7	25.0	25.7	26.8	24.1	24.4	25.1	26.2	23.0	23.3	24.0	25.1	21.7	22.0	22.7	23.8	20.5	20.8	21.5	22.6
	S/T	0.91	0.84	0.71	0.6	1.00	0.84	0.71	0.6	1.00	0.87	0.74	0.6	1.00	0.88	0.76	0.6	1.00	0.90	0.78	0.6	1.00	1.00	0.82	0.7
	ΔT	29	27	23	19	28	26	23	19	29	27	23	19	28	26	23	19	28	26	22	18	29	27	24	20
	kW	1.49	1.48	1.48	1.49	1.65	1.65	1.65	1.66	1.84	1.84	1.84	1.85	2.04	2.04	2.04	2.05	2.27	2.27	2.27	2.28	2.54	2.54	2.53	2.55
	Amps	5.4	5.4	5.4	5.4	6.2	6.1	6.1	6.2	7.0	7.0	7.0	7.1	7.9	7.9	7.9	8.0	9.0	9.0	9.0	9.0	10.2	10.2	10.2	10.2
900	MBh	25.4	25.8	26.5	27.6	25.2	25.6	26.3	27.4	24.6	24.9	25.7	26.8	23.5	23.9	24.6	25.7	22.2	22.5	23.3	24.4	21.0	21.3	22.1	23.2
	S/T	0.92	0.84	0.71	0.6	1.00	0.85	0.72	0.6	1.00	0.87	0.74	0.6	1.00	0.89	0.76	0.6	1.00	0.91	0.78	0.6	1.00	1.00	0.83	0.7
	ΔT	28	25	22	18	27	25	22	18	28	26	22	18	27	25	22	18	27	25	21	17	28	26	23	19
	kW	1.49	1.49	1.49	1.5	1.66	1.66	1.66	1.7	1.85	1.85	1.84	1.9	2.05	2.05	2.05	2.1	2.28	2.28	2.27	2.3	2.55	2.54	2.54	2.6
	Amps	5.4	5.4	5.4	5.5	6.2	6.2	6.2	6.2	7.0	7.0	7.0	7.1	8.0	8.0	8.0	8.0	9.0	9.0	9.0	9.1	10.2	10.2	10.2	10.3

IDB		OUTDOOR AMBIENT TEMPERATURE																							
		65				75				85				95				105				115			
		AIRFLOW	59	63	67	71	59	63	67	71	59	63	67	71	59	63	67	71	59	63	67	71	59	63	67
700	MBh	24.9	25.2	25.9	27.0	24.7	25.0	25.7	26.8	24.0	24.4	25.1	26.2	22.9	23.3	24.0	25.1	21.6	22.0	22.7	23.8	20.4	20.8	21.5	22.6
	S/T	1.00	0.90	0.77	0.6	1.00	0.90	0.77	0.6	1.00	0.93	0.80	0.7	1.00	0.94	0.82	0.7	1.00	1.00	0.84	0.7	1.00	1.00	0.89	0.8
	ΔT	34	32	28	24	34	32	28	24	34	32	28	24	34	32	28	24	33	31	28	24	35	33	29	25
	kW	1.48	1.48	1.48	1.5	1.65	1.65	1.64	1.7	1.84	1.84	1.83	1.8	2.04	2.04	2.04	2.0	2.27	2.27	2.26	2.3	2.53	2.53	2.53	2.5
	Amps	5.4	5.4	5.3	5.4	6.1	6.1	6.1	6.2	7.0	7.0	7.0	7.0	7.9	7.9	7.9	8.0	9.0	9.0	8.9	9.0	10.2	10.2	10.2	10.2
800	MBh	25.3	25.6	26.4	27.5	25.1	25.4	26.1	27.2	24.5	24.8	25.5	26.6	23.4	23.7	24.4	25.5	22.1	22.4	23.1	24.2	20.9	21.2	21.9	23.0
	S/T	1.00	0.93	0.80	0.7	1.00	0.94	0.81	0.7	1.00	0.96	0.83	0.7	1.00	1.00	0.85	0.7	1.00	1.00	0.87	0.7	1.00	1.00	0.92	0.8
	ΔT	33	31	27	23	32	30	27	23	33	31	27	23	32	30	27	23	32	30	26	22	33	31	28	24
	kW	1.49	1.49	1.48	1.50	1.66	1.66	1.65	1.67	1.84	1.84	1.84	1.85	2.05	2.05	2.04	2.06	2.27	2.27	2.27	2.28	2.54	2.54	2.54	2.55
	Amps	5.4	5.4	5.4	5.4	6.2	6.2	6.2	6.2	7.0	7.0	7.0	7.1	8.0	8.0	7.9	8.0	9.0	9.0	9.0	9.0	10.2	10.2	10.2	10.3
900	MBh	25.8	26.2	26.9	28.0	25.6	26.0	26.7	27.8	25.0	25.3	26.1	27.2	23.9	24.3	25.0	26.1	22.6	22.9	23.7	24.8	21.4	21.7	22.5	23.6
	S/T	1.00	0.94	0.81	0.7	1.00	0.94	0.82	0.7	1.00	0.97	0.84	0.7	1.00	1.00	0.86	0.7	1.00	1.00	0.88	0.7	1.00	1.00	0.93	0.8
	ΔT	32	29	26	22	31	29	26	22	32	30	26	22	31	29	26	22	31	29	25	21	32	30	27	23
	kW	1.50	1.49	1.49	1.5	1.66	1.66	1.66	1.7	1.85	1.85	1.85	1.9	2.06	2.05	2.05	2.1	2.28	2.28	2.28	2.3	2.55	2.55	2.54	2.6
	Amps	5.4	5.4	5.4	5.5	6.2	6.2	6.2	6.2	7.1	7.1	7.0	7.1	8.0	8.0	8.0	8.0	9.0	9.0	9.0	9.1	10.2	10.2	10.2	10.3

IDB: Entering Indoor Dry Bulb Temperature
 High and low pressures are measured at the liquid and suction service valves.
 Shaded area reflects AHRI conditions
 kW = Total system power
 Amps = outdoor unit amps (comp.+fan)

EXPANDED COOLING DATA — ALXS4NA3010A*+ CAPTA3026A*

IDB		OUTDOOR AMBIENT TEMPERATURE																							
		65				75				85				95				105				115			
		59	63	67	71	59	63	67	71	59	63	67	71	59	63	67	71	59	63	67	71	59	63	67	71
		ENTERING INDOOR WET BULB TEMPERATURE																							
		AIRFLOW																							
70	MBh	29.2	29.6	30.5	-	29.0	29.4	30.2	-	28.2	28.6	29.5	-	26.9	27.3	28.2	-	25.3	25.7	26.6	-	23.8	24.3	25.1	-
	S/T	0.62	0.54	0.41	-	0.62	0.55	0.42	-	0.65	0.57	0.44	-	0.67	0.59	0.46	-	0.69	0.61	0.48	-	0.74	0.66	0.53	-
	ΔT	21	19	15	-	21	19	15	-	21	19	15	-	21	19	15	-	20	18	15	-	22	20	16	-
	kW	1.80	1.80	1.80	-	2.00	2.00	1.99	-	2.22	2.22	2.22	-	2.46	2.46	2.46	-	2.73	2.73	2.72	-	3.04	3.04	3.04	-
	Amps	6.3	6.3	6.3	-	7.2	7.2	7.2	-	8.2	8.2	8.2	-	9.3	9.3	9.3	-	10.6	10.6	10.6	-	12.0	12.0	12.0	-
950	MBh	29.5	29.9	30.8	-	29.2	29.6	30.5	-	28.5	28.9	29.7	-	27.2	27.6	28.4	-	25.6	26.0	26.8	-	24.1	24.5	25.4	-
	S/T	0.65	0.58	0.44	-	0.66	0.58	0.45	-	0.68	0.61	0.47	-	0.70	0.63	0.49	-	0.72	0.65	0.52	-	0.77	0.70	0.57	-
	ΔT	20	18	14	-	20	18	14	-	20	18	15	-	20	18	14	-	20	18	14	-	21	19	15	-
	kW	1.81	1.81	1.80	-	2.01	2.00	2.00	-	2.23	2.23	2.22	-	2.47	2.47	2.46	-	2.74	2.73	2.73	-	3.05	3.05	3.05	-
	Amps	6.4	6.3	6.3	-	7.3	7.3	7.2	-	8.3	8.3	8.3	-	9.4	9.4	9.4	-	10.6	10.6	10.6	-	12.0	12.0	12.0	-
1125	MBh	30.2	30.6	31.5	-	29.9	30.3	31.2	-	29.2	29.6	30.4	-	27.9	28.3	29.1	-	26.3	26.7	27.5	-	24.8	25.2	26.1	-
	S/T	0.69	0.62	0.48	-	0.70	0.62	0.49	-	0.72	0.65	0.52	-	0.74	0.67	0.53	-	0.76	0.69	0.56	-	1.00	0.74	0.61	-
	ΔT	19	17	13	-	19	17	13	-	19	17	13	-	19	17	13	-	18	16	13	-	20	18	14	-
	kW	1.82	1.82	1.81	-	2.02	2.02	2.01	-	2.24	2.24	2.23	-	2.48	2.48	2.47	-	2.75	2.75	2.74	-	3.06	3.06	3.06	-
	Amps	6.4	6.4	6.4	-	7.3	7.3	7.3	-	8.3	8.3	8.3	-	9.4	9.4	9.4	-	10.7	10.7	10.6	-	12.1	12.1	12.1	-

IDB		OUTDOOR AMBIENT TEMPERATURE																							
		65				75				85				95				105				115			
		59	63	67	71	59	63	67	71	59	63	67	71	59	63	67	71	59	63	67	71	59	63	67	71
		ENTERING INDOOR WET BULB TEMPERATURE																							
		AIRFLOW																							
75	MBh	29.2	29.7	30.5	31.9	29.0	29.4	30.3	31.6	28.2	28.6	29.5	30.8	26.9	27.3	28.2	29.5	25.3	25.7	26.6	27.9	23.9	24.3	25.1	26.5
	S/T	0.74	0.67	0.54	0.4	0.75	0.67	0.54	0.4	0.77	0.70	0.57	0.4	0.79	0.72	0.59	0.4	1.00	0.74	0.61	0.5	1.00	0.79	0.66	0.5
	ΔT	25	23	19	16	25	23	19	16	25	23	20	16	25	23	19	16	25	23	19	15	26	24	20	17
	kW	1.80	1.80	1.79	1.8	2.00	2.00	1.99	2.0	2.22	2.22	2.21	2.2	2.46	2.46	2.46	2.5	2.73	2.73	2.72	2.7	3.04	3.04	3.04	3.1
	Amps	6.3	6.3	6.3	6.4	7.2	7.2	7.2	7.3	8.2	8.2	8.2	8.3	9.3	9.3	9.3	9.4	10.6	10.6	10.5	10.6	12.0	12.0	12.0	12.1
950	MBh	29.5	29.9	30.8	32.1	29.2	29.6	30.5	31.8	28.5	28.9	29.8	31.1	27.2	27.6	28.4	29.8	25.6	26.0	26.9	28.2	24.1	24.5	25.4	26.7
	S/T	0.78	0.70	0.57	0.4	0.78	0.71	0.58	0.4	0.81	0.73	0.60	0.5	0.83	0.75	0.62	0.5	1.00	0.77	0.64	0.5	1.00	0.82	0.69	0.6
	ΔT	24	22	19	15	24	22	19	15	25	23	19	15	24	22	19	15	24	22	18	15	25	23	20	16
	kW	1.81	1.80	1.80	1.82	2.00	2.00	2.00	2.01	2.23	2.22	2.22	2.24	2.47	2.46	2.46	2.48	2.73	2.73	2.73	2.74	3.05	3.05	3.04	3.06
	Amps	6.3	6.3	6.3	6.4	7.3	7.2	7.2	7.3	8.3	8.3	8.2	8.3	9.4	9.3	9.3	9.4	10.6	10.6	10.6	10.6	12.0	12.0	12.0	12.1
1125	MBh	30.2	30.6	31.5	32.8	29.9	30.4	31.2	32.6	29.2	29.6	30.5	31.8	27.9	28.3	29.2	30.5	26.3	26.7	27.6	28.9	24.8	25.2	26.1	27.4
	S/T	0.82	0.74	0.61	0.5	0.82	0.75	0.62	0.5	0.85	0.77	0.64	0.5	1.00	0.79	0.66	0.5	1.00	0.81	0.68	0.5	1.00	0.87	0.73	0.6
	ΔT	23	21	17	14	23	21	17	13	23	21	18	14	23	21	17	13	23	21	17	13	24	22	18	14
	kW	1.82	1.82	1.81	1.8	2.02	2.01	2.01	2.0	2.24	2.24	2.23	2.2	2.48	2.48	2.47	2.5	2.75	2.75	2.74	2.8	3.06	3.06	3.06	3.1
	Amps	6.4	6.4	6.4	6.4	7.3	7.3	7.3	7.4	8.3	8.3	8.3	8.4	9.4	9.4	9.4	9.5	10.7	10.6	10.6	10.7	12.1	12.1	12.1	12.1

IDB: Entering Indoor Dry Bulb Temperature
 High and low pressures are measured at the liquid and suction service valves.
 Shaded area reflects ACCA (TVA) conditions
 kW = Total system power
 Amps = outdoor unit amps (comp.+fan)

EXPANDED COOLING DATA — ALXS4NA3010A*+ CAPTA3026A* (CONT.)

IDB		OUTDOOR AMBIENT TEMPERATURE																																			
		65						75						85						95						105						115					
		AIRFLOW		59	63	67	71	59		63	67	71	59		63	67	71	59		63	67	71	59		63	67	71	59		63	67	71					
80	MBh	29.4	29.8	30.7	32.0	29.1	29.5	30.4	31.7	28.4	28.8	29.7	31.0	27.1	27.5	28.4	29.7	25.5	25.9	26.8	28.1	24.0	24.4	25.3	26.6	23.0	23.4	24.3	25.6	21.5	21.9	22.8	24.1				
	S/T	0.87	0.79	0.66	0.5	0.87	0.80	0.66	0.5	1.00	0.82	0.69	0.5	1.00	0.84	0.71	0.6	1.00	0.86	0.73	0.6	1.00	0.91	0.78	0.6	1.00	0.91	0.78	0.6	1.00	0.91	0.78	0.6				
	ΔT	29	27	24	20	29	27	24	20	30	28	24	20	29	27	24	20	29	27	23	20	30	28	25	21	30	28	25	21	30	28	25	21				
	kW	1.80	1.80	1.80	1.8	2.00	2.00	1.99	2.0	2.22	2.22	2.22	2.2	2.46	2.46	2.46	2.5	2.73	2.73	2.73	2.7	3.04	3.04	3.04	3.1	3.04	3.04	3.04	3.1	3.04	3.04	3.04	3.1				
	Amps	6.3	6.3	6.3	6.4	7.2	7.2	7.2	7.3	8.2	8.2	8.2	8.3	9.3	9.3	9.3	9.4	10.6	10.6	10.6	10.6	12.0	12.0	12.0	12.1	12.0	12.0	12.0	12.1	12.0	12.0	12.0	12.1				
950	MBh	29.6	30.1	30.9	32.3	29.4	29.8	30.7	32.0	28.6	29.0	29.9	31.2	27.3	27.7	28.6	29.9	25.7	26.1	27.0	28.3	24.3	24.7	25.5	26.9	23.0	23.4	24.3	25.6	21.5	21.9	22.8	24.1				
	S/T	0.90	0.83	0.69	0.6	0.91	0.83	0.70	0.6	1.00	0.86	0.72	0.6	1.00	0.87	0.74	0.6	1.00	0.90	0.76	0.6	1.00	0.95	0.81	0.7	1.00	0.95	0.81	0.7	1.00	0.95	0.81	0.7				
	ΔT	29	27	23	19	29	27	23	19	29	27	23	19	29	27	23	19	28	26	23	19	30	28	24	20	30	28	24	20	30	28	24	20				
	kW	1.81	1.80	1.80	1.82	2.01	2.00	2.00	2.02	2.23	2.23	2.22	2.24	2.47	2.47	2.46	2.48	2.74	2.73	2.73	2.75	3.05	3.05	3.05	3.06	3.05	3.05	3.05	3.06	3.05	3.05	3.05	3.06				
	Amps	6.3	6.3	6.3	6.4	7.3	7.3	7.2	7.3	8.3	8.3	8.3	8.3	9.4	9.4	9.4	9.4	10.6	10.6	10.6	10.6	12.0	12.0	12.0	12.1	12.0	12.0	12.0	12.1	12.0	12.0	12.0	12.1				
1125	MBh	30.4	30.8	31.6	33.0	30.1	30.5	31.4	32.7	29.3	29.7	30.6	31.9	28.0	28.4	29.3	30.6	26.4	26.8	27.7	29.0	25.0	25.4	26.3	27.6	23.5	23.9	24.8	26.1	22.0	22.4	23.3	24.6				
	S/T	0.94	0.87	0.73	0.6	1.00	0.87	0.74	0.6	1.00	0.90	0.76	0.6	1.00	0.92	0.78	0.6	1.00	0.94	0.80	0.7	1.00	1.00	0.86	0.7	1.00	1.00	0.86	0.7	1.00	1.00	0.86	0.7				
	ΔT	27	25	22	18	27	25	22	18	27	26	22	18	27	25	22	18	27	25	21	18	28	26	23	19	28	26	23	19	28	26	23	19				
	kW	1.82	1.82	1.81	1.8	2.02	2.02	2.01	2.0	2.24	2.24	2.23	2.2	2.48	2.48	2.47	2.5	2.75	2.75	2.74	2.8	3.06	3.06	3.06	3.1	3.06	3.06	3.06	3.1	3.06	3.06	3.06	3.1				
	Amps	6.4	6.4	6.4	6.5	7.3	7.3	7.3	7.4	8.3	8.3	8.3	8.4	9.4	9.4	9.4	9.5	10.7	10.7	10.7	10.7	12.1	12.1	12.1	12.1	12.1	12.1	12.1	12.1	12.1	12.1	12.1	12.1				

IDB		OUTDOOR AMBIENT TEMPERATURE																																			
		65						75						85						95						105						115					
		AIRFLOW		59	63	67	71	59		63	67	71	59		63	67	71	59		63	67	71	59		63	67	71	59		63	67	71					
875	MBh	29.9	30.3	31.2	32.5	29.6	30.0	30.9	32.2	28.9	29.3	30.1	31.5	27.6	28.0	28.8	30.2	26.0	26.4	27.2	28.6	24.5	24.9	25.8	27.1	23.0	23.4	24.3	25.6	21.5	21.9	22.8	24.1				
	S/T	1.00	0.89	0.76	0.6	1.00	0.90	0.76	0.6	1.00	0.92	0.79	0.6	1.00	0.94	0.81	0.7	1.00	1.00	0.83	0.7	1.00	1.00	0.88	0.7	1.00	1.00	0.88	0.7	1.00	1.00	0.88	0.7				
	ΔT	33	31	28	24	33	31	28	24	33	32	28	24	33	31	28	24	33	31	27	24	34	32	29	25	34	32	29	25	34	32	29	25				
	kW	1.80	1.80	1.80	1.8	2.00	2.00	2.00	2.0	2.22	2.22	2.22	2.2	2.46	2.46	2.46	2.5	2.73	2.73	2.73	2.7	3.05	3.05	3.05	3.1	3.05	3.05	3.05	3.1	3.05	3.05	3.05	3.1				
	Amps	6.3	6.3	6.3	6.4	7.2	7.2	7.2	7.3	8.3	8.3	8.2	8.3	9.4	9.4	9.3	9.4	10.6	10.6	10.6	10.6	12.0	12.0	12.0	12.1	12.0	12.0	12.0	12.1	12.0	12.0	12.0	12.1				
950	MBh	30.1	30.5	31.4	32.7	29.9	30.3	31.2	32.5	29.1	29.5	30.4	31.7	27.8	28.2	29.1	30.4	26.2	26.6	27.5	28.8	24.8	25.2	26.0	27.4	23.3	23.7	24.6	25.9	21.8	22.2	23.1	24.4				
	S/T	1.00	0.92	0.79	0.7	1.00	0.93	0.80	0.7	1.00	0.95	0.82	0.7	1.00	0.97	0.84	0.7	1.00	1.00	0.86	0.7	1.00	1.00	0.91	0.8	1.00	1.00	0.91	0.8	1.00	1.00	0.91	0.8				
	ΔT	33	31	27	23	32	31	27	23	33	31	27	23	32	31	27	23	32	30	27	23	33	31	28	24	33	31	28	24	33	31	28	24				
	kW	1.81	1.81	1.81	1.82	2.01	2.01	2.00	2.02	2.23	2.23	2.23	2.24	2.47	2.47	2.47	2.48	2.74	2.74	2.73	2.75	3.05	3.05	3.05	3.06	3.05	3.05	3.05	3.06	3.05	3.05	3.05	3.06				
	Amps	6.4	6.4	6.3	6.4	7.3	7.3	7.3	7.3	8.3	8.3	8.3	8.3	9.4	9.4	9.4	9.4	10.6	10.6	10.6	10.7	12.1	12.1	12.1	12.1	12.1	12.1	12.1	12.1	12.1	12.1	12.1	12.1				
1125	MBh	30.8	31.3	32.1	33.5	30.6	31.0	31.9	33.2	29.8	30.2	31.1	32.4	28.5	28.9	29.8	31.1	26.9	27.3	28.2	29.5	25.5	25.9	26.7	28.1	24.0	24.4	25.3	26.6	22.5	22.9	23.8	25.1				
	S/T	1.00	0.97	0.83	0.7	1.00	0.97	0.84	0.7	1.00	1.00	0.86	0.7	1.00	1.00	0.88	0.7	1.00	1.00	0.90	0.8	1.00	1.00	0.95	0.8	1.00	1.00	0.95	0.8	1.00	1.00	0.95	0.8				
	ΔT	31	29	25	22	31	29	25	22	31	29	26	22	31	29	25	22	31	29	25	21	32	30	26	23	32	30	26	23	32	30	26	23				
	kW	1.82	1.82	1.82	1.8	2.02	2.02	2.02	2.0	2.24	2.24	2.24	2.3	2.48	2.48	2.48	2.5	2.75	2.75	2.75	2.8	3.07	3.07	3.07	3.1	3.07	3.07	3.07	3.1	3.07	3.07	3.07	3.1				
	Amps	6.4	6.4	6.4	6.5	7.3	7.3	7.3	7.4	8.3	8.3	8.3	8.4	9.4	9.4	9.4	9.5	10.7	10.7	10.7	10.7	12.1	12.1	12.1	12.1	12.1	12.1	12.1	12.1	12.1	12.1	12.1	12.1				

IDB: Entering Indoor Dry Bulb Temperature
 High and low pressures are measured at the liquid and suction service valves.
 Shaded area reflects AHRI conditions
 kW = Total system power
 Amps = outdoor unit amps (comp.+fan)

EXPANDED COOLING DATA — ALXS4NA3610A*+ CAPTA3626A*

IDB		OUTDOOR AMBIENT TEMPERATURE																																			
		65						75						85						95						105						115					
		AIRFLOW				ENTERING INDOOR WET BULB TEMPERATURE				ENTERING INDOOR WET BULB TEMPERATURE				ENTERING INDOOR WET BULB TEMPERATURE				ENTERING INDOOR WET BULB TEMPERATURE				ENTERING INDOOR WET BULB TEMPERATURE				ENTERING INDOOR WET BULB TEMPERATURE				ENTERING INDOOR WET BULB TEMPERATURE							
	59	63	67	71	59	63	67	71	59	63	67	71	59	63	67	71	59	63	67	71	59	63	67	71	59	63	67	71									
1050	MBh	35.0	35.5	36.5	-	34.6	35.1	36.2	-	33.7	34.2	35.3	-	32.2	32.7	33.7	-	30.3	30.8	31.8	-	28.5	29.0	30.1	-	28.5	29.0	30.1	-								
	S/T	0.63	0.55	0.42	-	0.64	0.56	0.42	-	0.66	0.58	0.45	-	0.68	0.60	0.47	-	0.70	0.63	0.49	-	0.75	0.68	0.54	-	0.75	0.68	0.54	-								
	ΔT	20	18	15	-	20	18	15	-	21	19	15	-	20	18	15	-	20	18	14	-	21	19	16	-	21	19	16	-								
	kW	2.14	2.14	2.14	-	2.38	2.38	2.38	-	2.65	2.65	2.65	-	2.94	2.94	2.94	-	3.27	3.27	3.26	-	3.65	3.65	3.65	-	3.65	3.65	3.65	-								
	Amps	7.5	7.5	7.5	-	8.6	8.6	8.6	-	9.8	9.8	9.8	-	11.2	11.2	11.1	-	12.7	12.7	12.6	-	14.4	14.4	14.4	-	14.4	14.4	14.4	-								
1138	MBh	35.3	35.7	36.8	-	34.9	35.4	36.5	-	34.0	34.5	35.6	-	32.5	33.0	34.0	-	30.6	31.0	32.1	-	28.8	29.3	30.3	-	28.8	29.3	30.3	-								
	S/T	0.66	0.59	0.45	-	0.67	0.59	0.46	-	0.69	0.62	0.48	-	0.71	0.64	0.50	-	0.74	0.66	0.52	-	1.00	0.71	0.58	-	1.00	0.71	0.58	-								
	ΔT	20	18	14	-	20	18	14	-	20	18	14	-	20	18	14	-	19	17	14	-	20	19	15	-	20	19	15	-								
	kW	2.15	2.15	2.14	-	2.39	2.39	2.38	-	2.66	2.66	2.65	-	2.95	2.95	2.95	-	3.28	3.27	3.27	-	3.66	3.66	3.65	-	3.66	3.66	3.65	-								
	Amps	7.5	7.5	7.5	-	8.6	8.6	8.6	-	9.9	9.9	9.8	-	11.2	11.2	11.2	-	12.7	12.7	12.7	-	14.5	14.4	14.4	-	14.5	14.4	14.4	-								
1350	MBh	36.1	36.6	37.6	-	35.8	36.3	37.3	-	34.9	35.4	36.4	-	33.3	33.8	34.9	-	31.4	31.9	32.9	-	29.7	30.2	31.2	-	29.7	30.2	31.2	-								
	S/T	0.70	0.63	0.49	-	0.71	0.63	0.50	-	0.74	0.66	0.52	-	0.75	0.68	0.54	-	0.78	0.70	0.57	-	1.00	0.75	0.62	-	1.00	0.75	0.62	-								
	ΔT	18	16	13	-	18	16	13	-	18	16	13	-	18	16	13	-	18	16	12	-	19	17	14	-	19	17	14	-								
	kW	2.16	2.16	2.16	-	2.41	2.40	2.40	-	2.67	2.67	2.67	-	2.97	2.96	2.96	-	3.29	3.29	3.29	-	3.67	3.67	3.67	-	3.67	3.67	3.67	-								
	Amps	7.6	7.6	7.6	-	8.7	8.7	8.7	-	9.9	9.9	9.9	-	11.3	11.3	11.3	-	12.8	12.8	12.7	-	14.5	14.5	14.5	-	14.5	14.5	14.5	-								

IDB		OUTDOOR AMBIENT TEMPERATURE																																			
		65						75						85						95						105						115					
		AIRFLOW				ENTERING INDOOR WET BULB TEMPERATURE				ENTERING INDOOR WET BULB TEMPERATURE				ENTERING INDOOR WET BULB TEMPERATURE				ENTERING INDOOR WET BULB TEMPERATURE				ENTERING INDOOR WET BULB TEMPERATURE				ENTERING INDOOR WET BULB TEMPERATURE				ENTERING INDOOR WET BULB TEMPERATURE							
	59	63	67	71	59	63	67	71	59	63	67	71	59	63	67	71	59	63	67	71	59	63	67	71	59	63	67	71									
1050	MBh	35.0	35.5	36.5	38.1	34.7	35.2	36.2	37.8	33.8	34.3	35.3	36.9	32.2	32.7	33.7	35.3	30.3	30.8	31.8	33.4	28.5	29.0	30.1	31.7	28.5	29.0	30.1	31.7								
	S/T	0.76	0.68	0.55	0.4	0.76	0.69	0.55	0.4	0.79	0.71	0.58	0.4	0.81	0.73	0.60	0.5	1.00	0.75	0.62	0.5	1.00	0.81	0.67	0.5	1.00	0.81	0.67	0.5								
	ΔT	25	23	19	15	24	23	19	15	25	23	19	15	24	23	19	15	24	22	19	15	25	23	20	16	25	23	20	16								
	kW	2.14	2.14	2.13	2.2	2.38	2.38	2.38	2.4	2.65	2.65	2.64	2.7	2.94	2.94	2.94	3.0	3.27	3.27	3.26	3.3	3.65	3.65	3.64	3.7	3.65	3.65	3.64	3.7								
	Amps	7.5	7.5	7.5	7.6	8.6	8.6	8.6	8.7	9.8	9.8	9.8	9.9	11.2	11.2	11.1	11.2	12.7	12.7	12.6	12.7	14.4	14.4	14.4	14.5	14.4	14.4	14.4	14.5								
1138	MBh	35.3	35.8	36.8	38.4	35.0	35.5	36.5	38.1	34.1	34.5	35.6	37.2	32.5	33.0	34.0	35.6	30.6	31.1	32.1	33.7	28.8	29.3	30.4	32.0	28.8	29.3	30.4	32.0								
	S/T	0.79	0.72	0.58	0.4	0.80	0.72	0.59	0.4	0.82	0.75	0.61	0.5	0.84	0.77	0.63	0.5	1.00	0.79	0.65	0.5	1.00	0.84	0.70	0.6	1.00	0.84	0.70	0.6								
	ΔT	24	22	18	15	24	22	18	15	24	22	19	15	24	22	18	15	23	22	18	14	25	23	19	15	25	23	19	15								
	kW	2.15	2.15	2.14	2.16	2.39	2.39	2.38	2.40	2.66	2.66	2.65	2.67	2.95	2.95	2.94	2.96	3.28	3.27	3.27	3.29	3.66	3.66	3.65	3.67	3.66	3.66	3.65	3.67								
	Amps	7.5	7.5	7.5	7.6	8.6	8.6	8.6	8.7	9.9	9.9	9.8	9.9	11.2	11.2	11.2	11.3	12.7	12.7	12.7	12.8	14.4	14.4	14.4	14.5	14.4	14.4	14.4	14.5								
1350	MBh	36.1	36.6	37.7	39.2	35.8	36.3	37.3	38.9	34.9	35.4	36.4	38.0	33.3	33.8	34.9	36.5	31.4	31.9	33.0	34.6	29.7	30.2	31.2	32.8	29.7	30.2	31.2	32.8								
	S/T	0.83	0.76	0.62	0.5	0.84	0.76	0.63	0.5	0.86	0.79	0.65	0.5	1.00	0.81	0.67	0.5	1.00	0.83	0.69	0.6	1.00	0.88	0.75	0.6	1.00	0.88	0.75	0.6								
	ΔT	22	20	17	13	22	20	17	13	23	21	17	13	22	20	17	13	22	20	17	13	23	21	18	14	23	21	18	14								
	kW	2.16	2.16	2.16	2.2	2.40	2.40	2.40	2.4	2.67	2.67	2.67	2.7	2.96	2.96	2.96	3.0	3.29	3.29	3.28	3.3	3.67	3.67	3.67	3.7	3.67	3.67	3.67	3.7								
	Amps	7.6	7.6	7.6	7.7	8.7	8.7	8.7	8.8	9.9	9.9	9.9	10.0	11.3	11.3	11.2	11.3	12.8	12.8	12.7	12.8	14.5	14.5	14.5	14.6	14.5	14.5	14.5	14.6								

IDB: Entering Indoor Dry Bulb Temperature
 High and low pressures are measured at the liquid and suction service valves.
 Shaded area reflects ACCA (TVA) conditions
 kW = Total system power
 Amps = outdoor unit amps (comp.+fan)

EXPANDED COOLING DATA — ALXS4NA3610A*+ CAPTA3626A* (CONT.)

IDB		OUTDOOR AMBIENT TEMPERATURE																																				
		65						75						85						95						105						115						
		AIRFLOW	59	63	67	71	75	59	63	67	71	75	59	63	67	71	75	59	63	67	71	75	59	63	67	71	75	59	63	67	71	75						
		ENTERING INDOOR WET BULB TEMPERATURE																																				
80	1050	MBh	35.2	35.7	36.7	38.3	34.8	35.3	36.4	38.0	33.9	34.4	35.5	37.1	32.4	32.9	33.9	35.5	30.5	31.0	32.0	33.6	28.7	29.2	30.3	31.8	1.00	0.93	0.80	0.7	30.5	31.0	32.0	33.6	28.7	29.2	30.3	31.8
	S/T	0.88	0.81	0.67	0.5	0.89	0.81	0.68	0.5	1.00	0.84	0.70	0.6	1.00	0.86	0.72	0.6	1.00	0.88	0.74	0.6	1.00	0.93	0.80	0.7	1.00	0.88	0.74	0.6	1.00	0.88	0.74	0.6	1.00	0.93	0.80	0.7	
	ΔT	29	27	23	20	29	27	23	19	29	27	23	20	29	27	23	19	28	27	23	19	30	28	24	20	30	28	24	20	30	28	24	20	30	28	24	20	
	kW	2.14	2.14	2.14	2.2	2.38	2.38	2.38	2.4	2.65	2.65	2.65	2.7	2.94	2.94	2.94	3.0	3.27	3.27	3.26	3.3	3.65	3.65	3.65	3.7	3.65	3.65	3.65	3.7	3.65	3.65	3.65	3.7	3.65	3.65	3.65	3.7	
	Amps	7.5	7.5	7.5	7.6	8.6	8.6	8.6	8.7	9.8	9.8	9.8	9.9	11.2	11.2	11.1	11.2	12.7	12.7	12.6	12.7	14.4	14.4	14.4	14.5	14.4	14.4	14.4	14.5	14.4	14.4	14.4	14.5	14.4	14.4	14.4	14.5	
1138	MBh	35.5	35.9	37.0	38.6	35.1	35.6	36.7	38.3	34.2	34.7	35.8	37.4	32.7	33.2	34.2	35.8	30.8	31.2	32.3	33.9	29.0	29.5	30.5	32.1	30.8	31.2	32.3	33.9	29.0	29.5	30.5	32.1	30.8	31.2	32.3	33.9	
	S/T	0.92	0.84	0.71	0.6	0.92	0.85	0.71	0.6	1.00	0.87	0.74	0.6	1.00	0.89	0.76	0.6	1.00	0.91	0.78	0.6	1.00	0.96	0.83	0.7	1.00	0.91	0.78	0.6	1.00	0.96	0.83	0.7	1.00	0.96	0.83	0.7	
	ΔT	28	26	23	19	28	26	23	19	28	26	23	19	28	26	22	19	28	26	22	19	29	27	23	20	28	26	22	19	29	27	23	20	29	27	23	20	
	kW	2.15	2.15	2.14	2.16	2.39	2.39	2.38	2.40	2.66	2.66	2.65	2.67	2.95	2.95	2.94	2.96	3.28	3.27	3.27	3.29	3.66	3.66	3.66	3.67	3.66	3.66	3.66	3.67	3.66	3.66	3.66	3.67	3.66	3.66	3.66	3.67	
	Amps	7.5	7.5	7.5	7.6	8.6	8.6	8.6	8.7	9.9	9.9	9.8	9.9	11.2	11.2	11.2	11.3	12.7	12.7	12.7	12.8	14.4	14.4	14.4	14.5	14.4	14.4	14.4	14.5	14.4	14.4	14.4	14.5	14.4	14.4	14.4	14.5	
1350	MBh	36.3	36.8	37.8	39.4	36.0	36.5	37.5	39.1	35.1	35.6	36.6	38.2	33.5	34.0	35.1	36.6	31.6	32.1	33.1	34.7	29.9	30.4	31.4	33.0	31.6	32.1	33.1	34.7	29.9	30.4	31.4	33.0	31.6	32.1	33.1	34.7	
	S/T	0.96	0.88	0.75	0.6	1.00	0.89	0.75	0.6	1.00	0.91	0.78	0.6	1.00	0.93	0.80	0.7	1.00	0.95	0.82	0.7	1.00	1.00	0.87	0.7	1.00	0.95	0.82	0.7	1.00	1.00	0.87	0.7	1.00	1.00	0.87	0.7	
	ΔT	27	25	21	17	27	25	21	17	27	25	21	18	27	25	21	17	26	24	21	17	28	26	22	18	26	24	21	17	28	26	22	18	28	26	22	18	
	kW	2.16	2.16	2.16	2.2	2.41	2.40	2.40	2.4	2.67	2.67	2.67	2.7	2.97	2.96	2.96	3.0	3.29	3.29	3.29	3.3	3.67	3.67	3.67	3.7	3.67	3.67	3.67	3.7	3.67	3.67	3.67	3.7	3.67	3.67	3.67	3.7	
	Amps	7.6	7.6	7.6	7.7	8.7	8.7	8.7	8.8	9.9	9.9	9.9	10.0	11.3	11.3	11.3	11.3	12.8	12.8	12.7	12.8	14.5	14.5	14.5	14.6	14.5	14.5	14.5	14.6	14.5	14.5	14.5	14.6	14.5	14.5	14.5	14.6	

85	1050	MBh	35.7	36.2	37.3	38.9	35.4	35.9	37.0	38.6	34.5	35.0	36.1	37.6	33.0	33.5	34.5	36.1	31.1	31.5	32.6	34.2	29.3	29.8	30.8	32.4	31.1	31.5	32.6	34.2	29.3	29.8	30.8	32.4
	S/T	1.00	0.91	0.77	0.6	1.00	0.91	0.78	0.6	1.00	0.94	0.80	0.7	1.00	0.96	0.82	0.7	1.00	1.00	0.84	0.7	1.00	1.00	0.90	0.8	1.00	1.00	0.84	0.7	1.00	1.00	0.90	0.8	
	ΔT	33	31	27	23	32	31	27	23	33	31	27	24	32	31	27	23	32	30	27	23	33	31	28	24	32	30	27	23	33	31	28	24	
	kW	2.15	2.14	2.14	2.2	2.39	2.39	2.38	2.4	2.66	2.65	2.65	2.7	2.95	2.95	2.94	3.0	3.27	3.27	3.27	3.3	3.66	3.65	3.65	3.7	3.66	3.65	3.65	3.7	3.66	3.65	3.65	3.7	
	Amps	7.5	7.5	7.5	7.6	8.6	8.6	8.6	8.7	9.9	9.9	9.8	9.9	11.2	11.2	11.2	11.3	12.7	12.7	12.7	12.7	14.4	14.4	14.4	14.5	14.4	14.4	14.4	14.5	14.4	14.4	14.4	14.5	
1138	MBh	36.0	36.5	37.6	39.2	35.7	36.2	37.3	38.8	34.8	35.3	36.3	37.9	33.3	33.7	34.8	36.4	31.3	31.8	32.9	34.5	29.6	30.1	31.1	32.7	31.3	31.8	32.9	34.5	29.6	30.1	31.1	32.7	
	S/T	1.00	0.94	0.81	0.7	1.00	0.95	0.81	0.7	1.00	0.97	0.84	0.7	1.00	1.00	0.86	0.7	1.00	1.00	0.88	0.7	1.00	1.00	0.93	0.8	1.00	1.00	0.88	0.7	1.00	1.00	0.93	0.8	
	ΔT	32	30	26	23	32	30	26	23	32	30	27	23	32	30	26	23	32	30	26	22	33	31	27	23	32	30	26	22	33	31	27	23	
	kW	2.15	2.15	2.15	2.17	2.39	2.39	2.39	2.41	2.66	2.66	2.66	2.68	2.96	2.95	2.95	2.97	3.28	3.28	3.28	3.29	3.66	3.66	3.66	3.68	3.66	3.66	3.66	3.68	3.66	3.66	3.66	3.68	
	Amps	7.6	7.6	7.5	7.6	8.7	8.7	8.6	8.7	9.9	9.9	9.9	10.0	11.2	11.2	11.2	11.3	12.7	12.7	12.7	12.8	14.5	14.5	14.5	14.6	14.5	14.5	14.5	14.6	14.5	14.5	14.5	14.6	
1350	MBh	36.9	37.4	38.4	40.0	36.6	37.1	38.1	39.7	35.7	36.2	37.2	38.8	34.1	34.6	35.6	37.2	32.2	32.7	33.7	35.3	30.5	30.9	32.0	33.6	32.2	32.7	33.7	35.3	30.5	30.9	32.0	33.6	
	S/T	1.00	0.98	0.85	0.7	1.00	0.99	0.85	0.7	1.00	1.00	0.88	0.7	1.00	1.00	0.90	0.8	1.00	1.00	0.92	0.8	1.00	1.00	0.97	0.8	1.00	1.00	0.92	0.8	1.00	1.00	0.97	0.8	
	ΔT	30	29	25	21	30	28	25	21	31	29	25	21	30	28	25	21	30	28	25	21	31	29	26	22	30	28	25	21	31	29	26	22	
	kW	2.17	2.17	2.16	2.2	2.41	2.41	2.40	2.4	2.68	2.68	2.67	2.7	2.97	2.97	2.96	3.0	3.30	3.29	3.29	3.3	3.68	3.68	3.67	3.7	3.68	3.68	3.67	3.7	3.68	3.68	3.67	3.7	
	Amps	7.6	7.6	7.6	7.7	8.7	8.7	8.7	8.8	10.0	10.0	9.9	10.0	11.3	11.3	11.3	11.4	12.8	12.8	12.8	12.8	14.5	14.5	14.5	14.6	14.5	14.5	14.5	14.6	14.5	14.5	14.5	14.6	

IDB: Entering Indoor Dry Bulb Temperature
 High and low pressures are measured at the liquid and suction service valves.
 Shaded area reflects AHRI conditions
 kW = Total system power
 Amps = outdoor unit amps (comp.+fan)

EXPANDED COOLING DATA — ALXS4NA4210A*+ CAPTA4230A*

IDB		OUTDOOR AMBIENT TEMPERATURE																																			
		65						75						85						95						105						115					
		AIRFLOW				ENTERING INDOOR WET BULB TEMPERATURE				ENTERING INDOOR WET BULB TEMPERATURE				ENTERING INDOOR WET BULB TEMPERATURE				ENTERING INDOOR WET BULB TEMPERATURE				ENTERING INDOOR WET BULB TEMPERATURE				ENTERING INDOOR WET BULB TEMPERATURE				ENTERING INDOOR WET BULB TEMPERATURE							
	59	63	67	71	59	63	67	71	59	63	67	71	59	63	67	71	59	63	67	71	59	63	67	71	59	63	67	71									
70	MBh	40.6	41.2	42.4	-	40.2	40.8	42.0	-	39.2	39.8	41.0	-	37.4	37.9	39.1	-	35.1	35.7	36.9	-	33.1	33.7	34.9	-	33.1	33.7	34.9	-								
	S/T	0.60	0.53	0.39	-	0.61	0.53	0.39	-	0.63	0.56	0.42	-	0.65	0.58	0.44	-	0.68	0.60	0.46	-	0.73	0.65	0.51	-	0.73	0.65	0.51	-								
	ΔT	20	18	15	-	20	18	15	-	20	19	15	-	20	18	15	-	20	18	15	-	21	19	16	-	21	19	16	-								
	kW	2.51	2.51	2.50	-	2.79	2.79	2.78	-	3.10	3.10	3.09	-	3.43	3.43	3.43	-	3.81	3.81	3.80	-	4.25	4.25	4.24	-	4.25	4.25	4.24	-								
	Amps	8.6	8.6	8.6	-	9.9	9.9	9.8	-	11.3	11.3	11.3	-	12.8	12.8	12.8	-	14.5	14.5	14.5	-	16.5	16.5	16.5	-	16.5	16.5	16.5	-								
1225	MBh	41.2	41.8	43.0	-	40.9	41.4	42.7	-	39.8	40.4	41.6	-	38.0	38.5	39.8	-	35.7	36.3	37.5	-	33.7	34.3	35.5	-	33.7	34.3	35.5	-								
	S/T	0.68	0.60	0.46	-	0.68	0.61	0.47	-	0.71	0.63	0.49	-	0.73	0.65	0.51	-	0.75	0.67	0.54	-	1.00	0.73	0.59	-	1.00	0.73	0.59	-								
	ΔT	19	17	14	-	19	17	13	-	19	17	14	-	19	17	13	-	19	17	13	-	20	18	14	-	20	18	14	-								
	kW	2.53	2.53	2.52	-	2.81	2.80	2.80	-	3.12	3.11	3.11	-	3.45	3.45	3.44	-	3.83	3.82	3.82	-	4.27	4.26	4.26	-	4.27	4.26	4.26	-								
	Amps	8.7	8.7	8.6	-	9.9	9.9	9.9	-	11.4	11.4	11.3	-	12.9	12.9	12.9	-	14.6	14.6	14.6	-	16.6	16.6	16.6	-	16.6	16.6	16.6	-								
1575	MBh	41.7	42.3	43.5	-	41.4	41.9	43.1	-	40.3	40.9	42.1	-	38.5	39.0	40.3	-	36.2	36.8	38.0	-	34.2	34.8	36.0	-	34.2	34.8	36.0	-								
	S/T	0.71	0.63	0.49	-	0.71	0.63	0.50	-	0.74	0.66	0.52	-	0.76	0.68	0.54	-	0.78	0.70	0.56	-	1.00	0.75	0.62	-	1.00	0.75	0.62	-								
	ΔT	18	16	13	-	18	16	13	-	18	16	13	-	18	16	13	-	18	16	12	-	19	17	14	-	19	17	14	-								
	kW	2.54	2.54	2.53	-	2.82	2.81	2.81	-	3.13	3.12	3.12	-	3.46	3.46	3.45	-	3.84	3.83	3.83	-	4.27	4.27	4.27	-	4.27	4.27	4.27	-								
	Amps	8.7	8.7	8.7	-	10.0	10.0	10.0	-	11.4	11.4	11.4	-	12.9	12.9	12.9	-	14.7	14.6	14.6	-	16.7	16.7	16.7	-	16.7	16.7	16.6	-								

75	MBh	40.6	41.2	42.4	44.3	40.3	40.8	42.1	43.9	39.2	39.8	41.0	42.9	37.4	38.0	39.2	41.0	35.1	35.7	36.9	38.8	33.1	33.7	34.9	36.8
	S/T	0.73	0.66	0.52	0.4	0.74	0.66	0.52	0.4	0.77	0.69	0.55	0.4	0.79	0.71	0.57	0.4	1.00	0.73	0.59	0.4	1.00	0.78	0.64	0.5
	ΔT	24	22	19	15	24	22	19	15	24	23	19	16	24	22	19	15	24	22	19	15	25	23	20	16
	kW	2.51	2.51	2.50	2.5	2.79	2.78	2.78	2.8	3.10	3.09	3.09	3.1	3.43	3.43	3.43	3.4	3.81	3.80	3.80	3.8	4.25	4.24	4.24	4.3
	Amps	8.6	8.6	8.6	8.7	9.9	9.9	9.8	9.9	11.3	11.3	11.2	11.3	12.8	12.8	12.8	12.9	14.5	14.5	14.5	14.6	16.5	16.5	16.5	16.6
1225	MBh	41.3	41.8	43.0	44.9	40.9	41.5	42.7	44.5	39.8	40.4	41.6	43.5	38.0	38.6	39.8	41.6	35.8	36.3	37.6	39.4	33.7	34.3	35.5	37.4
	S/T	0.81	0.73	0.59	0.4	0.81	0.74	0.60	0.5	0.84	0.76	0.62	0.5	0.86	0.78	0.64	0.5	1.00	0.80	0.67	0.5	1.00	0.86	0.72	0.6
	ΔT	23	21	18	14	23	21	18	14	23	21	18	14	23	21	18	14	23	21	17	14	24	22	18	15
	kW	2.53	2.52	2.52	2.54	2.80	2.80	2.80	2.82	3.11	3.11	3.11	3.13	3.45	3.45	3.44	3.46	3.82	3.82	3.82	3.84	4.26	4.26	4.26	4.28
	Amps	8.7	8.7	8.6	8.7	9.9	9.9	9.9	10.0	11.4	11.3	11.3	11.4	12.9	12.9	12.9	13.0	14.6	14.6	14.6	14.7	16.6	16.6	16.6	16.7
1435	MBh	41.7	42.3	43.5	45.4	41.4	42.0	43.2	45.0	40.3	40.9	42.1	44.0	38.5	39.1	40.3	42.1	36.3	36.8	38.0	39.9	34.2	34.8	36.0	37.9
	S/T	0.84	0.76	0.62	0.5	0.84	0.77	0.63	0.5	0.87	0.79	0.65	0.5	1.00	0.81	0.67	0.5	1.00	0.83	0.70	0.6	1.00	0.89	0.75	0.6
	ΔT	22	20	17	13	22	20	17	13	22	21	17	13	22	20	17	13	22	20	17	13	23	21	18	14
	kW	2.54	2.53	2.53	2.6	2.81	2.81	2.81	2.8	3.12	3.12	3.12	3.1	3.46	3.46	3.45	3.5	3.83	3.83	3.83	3.8	4.27	4.27	4.27	4.3
	Amps	8.7	8.7	8.7	8.8	10.0	10.0	10.0	10.0	11.4	11.4	11.4	11.5	12.9	12.9	12.9	13.0	14.6	14.6	14.6	14.7	16.7	16.7	16.6	16.7
1575	MBh	41.7	42.3	43.5	45.4	41.4	42.0	43.2	45.0	40.3	40.9	42.1	44.0	38.5	39.1	40.3	42.1	36.3	36.8	38.0	39.9	34.2	34.8	36.0	37.9
	S/T	0.84	0.76	0.62	0.5	0.84	0.77	0.63	0.5	0.87	0.79	0.65	0.5	1.00	0.81	0.67	0.5	1.00	0.83	0.70	0.6	1.00	0.89	0.75	0.6
	ΔT	22	20	17	13	22	20	17	13	22	21	17	13	22	20	17	13	22	20	17	13	23	21	18	14
	kW	2.54	2.53	2.53	2.6	2.81	2.81	2.81	2.8	3.12	3.12	3.12	3.1	3.46	3.46	3.45	3.5	3.83	3.83	3.83	3.8	4.27	4.27	4.27	4.3
	Amps	8.7	8.7	8.7	8.8	10.0	10.0	10.0	10.0	11.4	11.4	11.4	11.5	12.9	12.9	12.9	13.0	14.6	14.6	14.6	14.7	16.7	16.7	16.6	16.7

IDB: Entering Indoor Dry Bulb Temperature
 High and low pressures are measured at the liquid and suction service valves.
 Shaded area reflects ACCA (TVA) conditions
 kW = Total system power
 Amps = outdoor unit amps (comp.+fan)

EXPANDED COOLING DATA — ALXS4NA4210A*+ CAPTA4230A* (CONT.)

IDB	AIRFLOW	OUTDOOR AMBIENT TEMPERATURE																							
		65				75				85				95				105				115			
		59	63	67	71	59	63	67	71	59	63	67	71	59	63	67	71	59	63	67	71	59	63	67	71
80	MBh	40.8	41.4	42.6	44.5	40.5	41.1	42.3	44.1	39.4	40.0	41.2	43.1	37.6	38.2	39.4	41.2	35.4	35.9	37.1	39.0	33.3	33.9	35.1	37.0
	S/T	0.86	0.78	0.65	0.5	0.87	0.79	0.65	0.5	1.00	0.82	0.68	0.5	1.00	0.84	0.70	0.6	1.00	0.86	0.72	0.6	1.00	0.91	0.77	0.6
	ΔT	28	26	23	19	28	26	23	19	29	27	23	20	28	26	23	19	28	26	23	19	29	27	24	20
	kW	2.51	2.51	2.50	2.5	2.79	2.79	2.78	2.8	3.10	3.10	3.09	3.1	3.43	3.43	3.43	3.4	3.81	3.81	3.80	3.8	4.25	4.25	4.24	4.3
	Amps	8.6	8.6	8.6	8.7	9.9	9.9	9.8	9.9	11.3	11.3	11.3	11.4	12.8	12.8	12.8	12.9	14.5	14.5	14.5	14.6	16.5	16.5	16.5	16.6
80	MBh	41.5	42.0	43.3	45.1	41.1	41.7	42.9	44.7	40.0	40.6	41.8	43.7	38.2	38.8	40.0	41.9	36.0	36.5	37.8	39.6	33.9	34.5	35.7	37.6
	S/T	0.94	0.86	0.72	0.6	0.94	0.86	0.73	0.6	1.00	0.89	0.75	0.6	1.00	0.91	0.77	0.6	1.00	0.93	0.79	0.6	1.00	1.00	0.85	0.7
	ΔT	27	25	22	18	27	25	22	18	27	25	22	18	27	25	22	18	27	25	21	18	28	26	23	19
	kW	2.53	2.53	2.52	2.54	2.81	2.80	2.80	2.82	3.12	3.11	3.11	3.13	3.45	3.45	3.44	3.47	3.83	3.82	3.82	3.84	4.26	4.26	4.26	4.28
	Amps	8.7	8.7	8.6	8.7	9.9	9.9	9.9	10.0	11.4	11.4	11.3	11.4	12.9	12.9	12.9	13.0	14.6	14.6	14.6	14.7	16.6	16.6	16.6	16.7
80	MBh	42.0	42.5	43.7	45.6	41.6	42.2	43.4	45.2	40.5	41.1	42.3	44.2	38.7	39.3	40.5	42.3	36.5	37.0	38.3	40.1	34.4	35.0	36.2	38.1
	S/T	0.96	0.89	0.75	0.6	1.00	0.89	0.76	0.6	1.00	0.92	0.78	0.6	1.00	0.94	0.80	0.7	1.00	0.96	0.82	0.7	1.00	1.00	0.88	0.7
	ΔT	26	24	21	17	26	24	21	17	26	25	21	18	26	24	21	17	26	24	21	17	27	25	22	18
	kW	2.54	2.54	2.53	2.6	2.82	2.81	2.81	2.8	3.13	3.12	3.12	3.1	3.46	3.46	3.45	3.5	3.83	3.83	3.83	3.8	4.27	4.27	4.27	4.3
	Amps	8.7	8.7	8.7	8.8	10.0	10.0	10.0	10.1	11.4	11.4	11.4	11.5	12.9	12.9	12.9	13.0	14.7	14.6	14.6	14.7	16.7	16.7	16.7	16.8

85	MBh	41.5	42.1	43.3	45.2	41.2	41.7	43.0	44.8	40.1	40.7	41.9	43.8	38.3	38.9	40.1	41.9	36.0	36.6	37.8	39.7	34.0	34.6	35.8	37.7
	S/T	1.00	0.89	0.75	0.6	1.00	0.89	0.76	0.6	1.00	0.92	0.78	0.6	1.00	0.94	0.80	0.7	1.00	1.00	0.82	0.7	1.00	1.00	0.88	0.7
	ΔT	32	30	27	23	32	30	27	23	32	30	27	23	32	30	27	23	32	30	26	23	33	31	27	24
	kW	2.52	2.51	2.51	2.5	2.79	2.79	2.79	2.8	3.10	3.10	3.10	3.1	3.44	3.44	3.43	3.5	3.81	3.81	3.81	3.8	4.25	4.25	4.25	4.3
	Amps	8.6	8.6	8.6	8.7	9.9	9.9	9.9	10.0	11.3	11.3	11.3	11.4	12.8	12.8	12.8	12.9	14.6	14.5	14.5	14.6	16.6	16.6	16.5	16.6
85	MBh	42.2	42.7	43.9	45.8	41.8	42.4	43.6	45.4	40.7	41.3	42.5	44.4	38.9	39.5	40.7	42.5	36.7	37.2	38.5	40.3	34.6	35.2	36.4	38.3
	S/T	1.00	0.96	0.82	0.7	1.00	0.97	0.83	0.7	1.00	0.99	0.86	0.7	1.00	1.00	0.87	0.7	1.00	1.00	0.90	0.8	1.00	1.00	0.95	0.8
	ΔT	31	29	25	22	31	29	25	22	31	29	26	22	31	29	25	22	30	28	25	21	31	30	26	23
	kW	2.53	2.53	2.53	2.55	2.81	2.81	2.80	2.83	3.12	3.12	3.11	3.14	3.46	3.45	3.45	3.47	3.83	3.83	3.82	3.84	4.27	4.27	4.26	4.28
	Amps	8.7	8.7	8.7	8.8	10.0	10.0	9.9	10.0	11.4	11.4	11.4	11.5	12.9	12.9	12.9	13.0	14.6	14.6	14.6	14.7	16.6	16.6	16.6	16.7
85	MBh	42.6	43.2	44.4	46.3	42.3	42.9	44.1	45.9	41.2	41.8	43.0	44.9	39.4	40.0	41.2	43.0	37.2	37.7	38.9	40.8	35.1	35.7	36.9	38.8
	S/T	1.00	0.99	0.85	0.7	1.00	1.00	0.86	0.7	1.00	1.00	0.88	0.7	1.00	1.00	0.90	0.8	1.00	1.00	0.93	0.8	1.00	1.00	0.98	0.8
	ΔT	30	28	25	21	30	28	25	21	30	28	25	21	30	28	24	21	30	28	24	21	31	29	25	22
	kW	2.54	2.54	2.54	2.6	2.82	2.82	2.81	2.8	3.13	3.13	3.12	3.1	3.47	3.46	3.46	3.5	3.84	3.84	3.83	3.9	4.28	4.28	4.27	4.3
	Amps	8.7	8.7	8.7	8.8	10.0	10.0	10.0	10.1	11.4	11.4	11.4	11.5	13.0	13.0	12.9	13.0	14.7	14.7	14.6	14.7	16.7	16.7	16.7	16.8

IDB: Entering Indoor Dry Bulb Temperature
 High and low pressures are measured at the liquid and suction service valves.
 Shaded area reflects AHRI conditions
 kW = Total system power
 Amps = outdoor unit amps (comp.+fan)

EXPANDED COOLING DATA — ALXS4NA4810A*+ CAPTA6030A* (CONT.)

IDB		OUTDOOR AMBIENT TEMPERATURE																																			
		65						75						85						95						105						115					
		59	63	67	71	59	63	67	71	59	63	67	71	59	63	67	71	59	63	67	71	59	63	67	71	59	63	67	71								
		ENTERING INDOOR WET BULB TEMPERATURE																																			
AIRFLOW		47.2	47.8	49.2	51.3	46.8	47.4	48.8	50.9	45.5	46.2	47.6	49.7	43.5	44.1	45.5	47.6	40.9	41.6	43.0	45.1	38.6	39.3	40.6	42.8												
		0.88	0.80	0.68	0.5	0.88	0.81	0.68	0.5	1.00	0.83	0.70	0.6	1.00	0.85	0.72	0.6	1.00	0.87	0.74	0.6	1.00	0.92	0.79	0.7												
1400		ΔT	29	27	23	19	29	27	23	19	29	27	23	19	29	27	23	19	28	26	23	19	30	28	24	20											
		kW	2.84	2.84	2.83	2.9	3.17	3.16	3.16	3.2	3.53	3.53	3.52	3.5	3.93	3.92	3.92	3.9	4.37	4.37	4.36	4.4	4.89	4.88	4.88	4.9											
		Amps	10.2	10.2	10.1	10.2	11.7	11.7	11.6	11.7	13.3	13.3	13.4	13.4	15.1	15.1	15.1	15.2	17.2	17.2	17.1	17.2	19.5	19.5	19.5	19.6											
		MBh	48.0	48.7	50.0	52.2	47.6	48.3	49.6	51.7	46.4	47.0	48.4	50.5	44.3	45.0	46.3	48.5	41.8	42.4	43.8	45.9	39.4	40.1	41.5	43.6											
80		S/T	0.91	0.84	0.71	0.6	0.92	0.85	0.72	0.6	1.00	0.87	0.74	0.6	1.00	0.89	0.76	0.6	1.00	0.91	0.78	0.6	1.00	0.96	0.83	0.7											
		ΔT	28	26	22	18	28	26	22	18	28	26	22	18	28	26	22	18	27	25	22	18	29	27	23	19											
		kW	2.85	2.85	2.85	2.87	3.18	3.18	3.17	3.20	3.55	3.54	3.54	3.56	3.94	3.94	3.93	3.96	4.38	4.38	4.38	4.40	4.90	4.90	4.90	4.92											
		Amps	10.2	10.2	10.2	10.3	11.7	11.7	11.7	11.8	13.4	13.4	13.4	13.5	15.2	15.2	15.2	15.3	17.2	17.2	17.2	17.3	19.6	19.6	19.6	19.7											
		MBh	49.1	49.7	51.1	53.2	48.6	49.3	50.7	52.8	47.4	48.1	49.5	51.6	45.4	46.0	47.4	49.5	42.8	43.5	44.8	47.0	40.5	41.1	42.5	44.6											
1800		S/T	0.92	0.85	0.72	0.6	1.00	0.85	0.72	0.6	1.00	0.88	0.75	0.6	1.00	0.90	0.77	0.6	1.00	0.92	0.79	0.7	1.00	1.00	0.84	0.7											
		ΔT	27	25	21	17	27	25	21	17	27	25	21	17	27	25	21	17	26	24	21	17	28	26	22	18											
		kW	2.87	2.87	2.86	2.9	3.20	3.19	3.19	3.2	3.56	3.56	3.55	3.6	3.96	3.95	3.95	4.0	4.40	4.40	4.39	4.4	4.92	4.91	4.91	4.9											
		Amps	10.3	10.3	10.3	10.4	11.8	11.8	11.8	11.9	13.5	13.5	13.4	13.6	15.3	15.3	15.2	15.4	17.3	17.3	17.3	17.4	19.7	19.7	19.7	19.8											

		47.9	48.6	50.0	52.1	47.5	48.2	49.6	51.7	46.3	47.0	48.4	50.5	44.2	44.9	46.3	48.4	41.7	42.4	43.7	45.9	39.4	40.0	41.4	43.5	
1400		S/T	1.00	0.90	0.77	0.6	1.00	0.91	0.78	0.6	1.00	0.93	0.80	0.7	1.00	0.95	0.82	0.7	1.00	1.00	0.84	0.7	1.00	1.00	0.89	0.8
		ΔT	33	31	27	23	33	31	27	23	33	31	27	23	33	31	27	23	32	30	27	23	34	32	28	24
		kW	2.84	2.84	2.84	2.9	3.17	3.17	3.16	3.2	3.54	3.53	3.53	3.6	3.93	3.93	3.92	3.9	4.37	4.37	4.37	4.4	4.89	4.89	4.89	4.9
		Amps	10.2	10.2	10.2	10.3	11.7	11.7	11.7	11.8	13.4	13.4	13.3	13.4	15.2	15.2	15.1	15.3	17.2	17.2	17.2	17.3	19.6	19.6	19.5	19.6
		MBh	48.8	49.4	50.8	52.9	48.4	49.0	50.4	52.5	47.2	47.8	49.2	51.3	45.1	45.7	47.1	49.2	42.5	43.2	44.6	46.7	40.2	40.9	42.3	44.4
85		S/T	1.00	0.94	0.81	0.7	1.00	0.94	0.81	0.7	1.00	0.97	0.84	0.7	1.00	0.98	0.86	0.7	1.00	1.00	0.88	0.7	1.00	1.00	0.93	0.8
		ΔT	32	30	26	22	31	30	26	22	32	30	26	22	31	29	26	22	31	29	26	22	32	30	27	23
		kW	2.86	2.86	2.85	2.88	3.19	3.19	3.18	3.20	3.55	3.55	3.55	3.57	3.95	3.95	3.94	3.97	4.39	4.39	4.38	4.41	4.91	4.91	4.90	4.93
		Amps	10.3	10.3	10.2	10.3	11.8	11.8	11.7	11.8	13.4	13.4	13.4	13.5	15.2	15.2	15.2	15.3	17.3	17.3	17.2	17.3	19.6	19.6	19.6	19.7
		MBh	49.8	50.5	51.9	54.0	49.4	50.1	51.5	53.6	48.2	48.9	50.2	52.4	46.1	46.8	48.2	50.3	43.6	44.2	45.6	47.7	41.3	41.9	43.3	45.4
1800		S/T	1.00	0.94	0.81	0.7	1.00	0.95	0.82	0.7	1.00	0.97	0.84	0.7	1.00	1.00	0.86	0.7	1.00	1.00	0.88	0.7	1.00	1.00	0.93	0.8
		ΔT	31	29	25	21	30	29	25	21	31	29	25	21	30	28	25	21	30	28	25	21	31	29	26	22
		kW	2.87	2.87	2.87	2.9	3.20	3.20	3.19	3.2	3.57	3.56	3.56	3.6	3.96	3.96	3.95	4.0	4.41	4.40	4.40	4.4	4.92	4.92	4.92	4.9
		Amps	10.3	10.3	10.3	10.4	11.8	11.8	11.8	11.9	13.5	13.5	13.5	13.6	15.3	15.3	15.3	15.4	17.3	17.3	17.3	17.4	19.7	19.7	19.7	19.8

IDB: Entering Indoor Dry Bulb Temperature
 High and low pressures are measured at the liquid and suction service valves.
 Shaded area reflects AHRI conditions
 kW = Total system power
 Amps = outdoor unit amps (comp.+fan)

EXPANDED COOLING DATA — ALXS4NA6010A*+ CAPTA6030A*

IDB		OUTDOOR AMBIENT TEMPERATURE																																			
		65						75						85						95						105						115					
		AIRFLOW				ENTERING INDOOR WET BULB TEMPERATURE				ENTERING INDOOR WET BULB TEMPERATURE				ENTERING INDOOR WET BULB TEMPERATURE				ENTERING INDOOR WET BULB TEMPERATURE				ENTERING INDOOR WET BULB TEMPERATURE				ENTERING INDOOR WET BULB TEMPERATURE				ENTERING INDOOR WET BULB TEMPERATURE							
	59	63	67	71	59	63	67	71	59	63	67	71	59	63	67	71	59	63	67	71	59	63	67	71	59	63	67	71									
70	1500	MBh	58.8	59.6	61.3	-	58.2	59.1	60.8	-	56.7	57.5	59.3	-	54.1	54.9	56.7	-	50.9	51.7	53.5	-	48.0	48.8	50.6	-	0.71	0.64	0.52	-							
		S/T	0.60	0.53	0.41	-	0.61	0.54	0.41	-	0.63	0.56	0.44	-	0.65	0.58	0.46	-	0.67	0.60	0.48	-	0.71	0.64	0.52	-	0.71	0.64	0.52	-							
		ΔT	22	20	16	-	22	20	16	-	22	20	16	-	22	20	16	-	22	19	15	-	23	21	17	-	23	21	17	-							
		kW	3.66	3.65	3.65	-	4.10	4.10	4.09	-	4.60	4.60	4.59	-	5.14	5.14	5.13	-	5.74	5.74	5.73	-	6.45	6.45	6.44	-	6.45	6.45	6.44	-							
		Amps	13.7	13.7	13.7	-	15.8	15.7	15.7	-	18.0	18.0	18.0	-	20.5	20.5	20.4	-	23.3	23.2	23.2	-	26.5	26.5	26.4	-	26.5	26.5	26.4	-							
70	2000	MBh	61.6	62.4	64.2	-	61.1	61.9	63.6	-	59.6	60.4	62.1	-	57.0	57.8	59.5	-	53.8	54.6	56.3	-	50.9	51.7	53.4	-	0.75	0.68	0.56	-							
		S/T	0.64	0.57	0.45	-	0.64	0.57	0.45	-	0.67	0.60	0.47	-	0.68	0.61	0.49	-	0.70	0.63	0.51	-	0.75	0.68	0.56	-	0.75	0.68	0.56	-							
		ΔT	19	17	13	-	19	17	13	-	19	17	13	-	19	17	13	-	19	17	13	-	20	18	14	-	20	18	14	-							
		kW	3.70	3.70	3.69	-	4.15	4.15	4.14	-	4.65	4.65	4.64	-	5.19	5.18	5.18	-	5.79	5.79	5.78	-	6.50	6.49	6.49	-	6.50	6.49	6.49	-							
		Amps	13.9	13.9	13.9	-	16.0	16.0	15.9	-	18.2	18.2	18.2	-	20.7	20.7	20.7	-	23.5	23.5	23.4	-	26.7	26.7	26.7	-	26.7	26.7	26.7	-							
70	2250	MBh	63.6	64.4	66.2	-	63.1	63.9	65.7	-	61.6	62.4	64.1	-	59.0	59.8	61.5	-	55.8	56.6	58.4	-	52.9	53.7	55.4	-	0.72	0.65	0.53	-							
		S/T	0.61	0.54	0.41	-	0.61	0.54	0.42	-	0.63	0.57	0.44	-	0.65	0.58	0.46	-	0.67	0.60	0.48	-	0.72	0.65	0.53	-	0.72	0.65	0.53	-							
		ΔT	18	16	12	-	18	16	12	-	18	16	12	-	18	16	12	-	18	16	12	-	19	17	13	-	19	17	13	-							
		kW	3.72	3.72	3.71	-	4.17	4.17	4.16	-	4.67	4.67	4.66	-	5.21	5.21	5.20	-	5.81	5.81	5.80	-	6.52	6.52	6.51	-	6.52	6.52	6.51	-							
		Amps	14.0	14.0	14.0	-	16.1	16.0	16.0	-	18.3	18.3	18.3	-	20.8	20.8	20.8	-	23.6	23.6	23.5	-	26.8	26.8	26.8	-	26.8	26.8	26.8	-							

IDB		OUTDOOR AMBIENT TEMPERATURE																																			
		65						75						85						95						105						115					
		AIRFLOW				ENTERING INDOOR WET BULB TEMPERATURE				ENTERING INDOOR WET BULB TEMPERATURE				ENTERING INDOOR WET BULB TEMPERATURE				ENTERING INDOOR WET BULB TEMPERATURE				ENTERING INDOOR WET BULB TEMPERATURE				ENTERING INDOOR WET BULB TEMPERATURE				ENTERING INDOOR WET BULB TEMPERATURE							
	59	63	67	71	59	63	67	71	59	63	67	71	59	63	67	71	59	63	67	71	59	63	67	71	59	63	67	71									
75	1500	MBh	58.8	59.6	61.3	64.0	58.3	59.1	60.8	63.5	56.8	57.6	59.3	62.0	54.1	55.0	56.7	59.3	51.0	51.8	53.5	56.2	48.1	48.9	50.6	53.3	0.83	0.76	0.64	0.5							
		S/T	0.72	0.65	0.53	0.4	0.72	0.65	0.53	0.4	0.74	0.68	0.55	0.4	0.76	0.69	0.57	0.4	0.78	0.71	0.59	0.5	0.88	0.76	0.64	0.5	0.88	0.76	0.64	0.5							
		ΔT	27	24	20	16	27	24	20	16	27	25	21	17	27	24	20	16	26	24	20	16	28	25	21	17	28	25	21	17							
		kW	3.65	3.65	3.64	3.7	4.10	4.10	4.09	4.1	4.60	4.60	4.59	4.6	5.14	5.13	5.13	5.2	5.74	5.74	5.73	5.8	6.45	6.44	6.44	6.5	6.45	6.44	6.44	6.5							
		Amps	13.7	13.7	13.6	13.8	15.7	15.7	15.7	15.8	18.0	18.0	18.0	18.1	20.5	20.5	20.4	20.6	23.2	23.2	23.2	23.4	26.5	26.5	26.4	26.6	26.5	26.5	26.4	26.6							
75	2000	MBh	61.6	62.5	64.2	66.8	61.1	61.9	63.7	66.3	59.6	60.4	62.2	64.8	57.0	57.8	59.6	62.2	53.8	54.6	56.4	59.0	50.9	51.7	53.5	56.1	1.00	0.80	0.67	0.5							
		S/T	0.75	0.68	0.56	0.4	0.76	0.69	0.57	0.4	0.78	0.71	0.59	0.5	0.80	0.73	0.61	0.5	0.82	0.75	0.63	0.5	1.00	0.80	0.67	0.5	1.00	0.80	0.67	0.5							
		ΔT	24	22	18	14	24	22	18	14	24	22	18	14	24	22	18	14	24	21	17	13	25	23	19	15	25	23	19	15							
		kW	3.70	3.70	3.69	3.72	4.15	4.14	4.14	4.17	4.65	4.64	4.64	4.67	5.19	5.17	5.17	5.21	5.79	5.78	5.78	5.81	6.50	6.49	6.48	6.52	6.50	6.49	6.48	6.52							
		Amps	13.9	13.9	13.9	14.0	16.0	15.9	15.9	16.1	18.2	18.2	18.2	18.3	20.7	20.7	20.7	20.8	23.5	23.4	23.4	23.6	26.7	26.7	26.6	26.8	26.7	26.7	26.6	26.8							
75	2250	MBh	63.7	64.5	66.2	68.9	63.1	64.0	65.7	68.3	61.6	62.4	64.2	66.8	59.0	59.8	61.6	64.2	55.8	56.7	58.4	61.0	52.9	53.8	55.5	58.1	1.00	0.77	0.64	0.5							
		S/T	0.72	0.65	0.53	0.4	0.73	0.66	0.54	0.4	0.75	0.68	0.56	0.4	0.77	0.70	0.58	0.4	1.00	0.72	0.60	0.5	1.00	0.77	0.64	0.5	1.00	0.77	0.64	0.5							
		ΔT	23	21	17	12	23	21	17	12	23	21	17	13	23	21	17	12	22	20	16	12	24	22	18	13	24	22	18	13							
		kW	3.72	3.72	3.71	3.7	4.17	4.16	4.16	4.2	4.67	4.66	4.66	4.7	5.21	5.20	5.19	5.2	5.81	5.81	5.80	5.8	6.52	6.51	6.50	6.5	6.52	6.51	6.50	6.5							
		Amps	14.0	14.0	14.0	14.1	16.0	16.0	16.0	16.2	18.3	18.3	18.3	18.4	20.8	20.8	20.7	20.9	23.6	23.5	23.5	23.7	26.8	26.8	26.8	26.9	26.8	26.8	26.8	26.9							

IDB: Entering Indoor Dry Bulb Temperature
 High and low pressures are measured at the liquid and suction service valves.
 Shaded area reflects ACCA (TVA) conditions
 kW = Total system power
 Amps = outdoor unit amps (comp.+fan)

EXPANDED COOLING DATA — ALXS4NA6010A*+ CAPTA6030A* (CONT.)

IDB	AIRFLOW	OUTDOOR AMBIENT TEMPERATURE																							
		65				75				85				95				105				115			
		59	63	67	71	59	63	67	71	59	63	67	71	59	63	67	71	59	63	67	71	59	63	67	71
80	MBh	59.1	59.9	61.6	64.3	58.6	59.4	61.1	63.8	57.1	57.9	59.6	62.3	54.4	55.3	57.0	59.6	51.3	52.1	53.8	56.5	48.4	49.2	50.9	53.6
	S/T	0.83	0.76	0.64	0.5	0.84	0.77	0.64	0.5	0.86	0.79	0.67	0.5	1.00	0.81	0.68	0.6	1.00	0.83	0.70	0.6	1.00	0.87	0.75	0.6
	ΔT	31	29	25	21	31	29	25	21	32	29	25	21	31	29	25	21	31	29	25	21	32	30	26	22
	kW	3.66	3.65	3.65	3.7	4.10	4.10	4.09	4.1	4.60	4.60	4.59	4.6	5.14	5.14	5.13	5.2	5.74	5.74	5.73	5.8	6.45	6.45	6.44	6.5
	Amps	13.7	13.7	13.7	13.8	15.7	15.7	15.7	15.9	18.0	18.0	18.0	18.1	20.5	20.5	20.4	20.6	23.3	23.2	23.2	23.4	26.5	26.5	26.4	26.6
	MBh	61.9	62.8	64.5	67.1	61.4	62.2	64.0	66.6	59.9	60.7	62.5	65.1	57.3	58.1	59.9	62.5	54.1	54.9	56.7	59.3	51.2	52.0	53.8	56.4
	S/T	0.87	0.80	0.68	0.5	0.87	0.80	0.68	0.6	1.00	0.83	0.70	0.6	1.00	0.84	0.72	0.6	1.00	0.86	0.74	0.6	1.00	0.91	0.79	0.7
	ΔT	29	27	23	18	29	27	23	18	29	27	23	19	29	26	22	18	28	26	22	18	30	28	24	19
	kW	3.70	3.70	3.69	3.73	4.15	4.15	4.14	4.17	4.65	4.65	4.64	4.67	5.19	5.18	5.18	5.21	5.79	5.79	5.78	5.81	6.50	6.49	6.49	6.52
	Amps	13.9	13.9	13.9	14.0	16.0	15.9	15.9	16.1	18.2	18.2	18.2	18.4	20.7	20.7	20.7	20.8	23.5	23.5	23.4	23.6	26.7	26.7	26.7	26.8
MBh	64.0	64.8	66.5	69.2	63.4	64.3	66.0	68.6	61.9	62.7	64.5	67.1	59.3	60.1	61.9	64.5	56.1	57.0	58.7	61.3	53.2	54.1	55.8	58.4	
S/T	0.83	0.77	0.64	0.5	0.84	0.77	0.65	0.5	1.00	0.79	0.67	0.5	1.00	0.81	0.69	0.6	1.00	0.83	0.71	0.6	1.00	0.88	0.76	0.6	
ΔT	28	25	21	17	27	25	21	17	28	26	22	17	27	25	21	17	27	25	21	17	29	26	22	18	
kW	3.72	3.72	3.71	3.7	4.17	4.17	4.16	4.2	4.67	4.67	4.66	4.7	5.21	5.20	5.20	5.2	5.81	5.81	5.80	5.8	6.52	6.51	6.51	6.5	
Amps	14.0	14.0	14.0	14.1	16.1	16.0	16.0	16.2	18.3	18.3	18.3	18.4	20.8	20.8	20.8	20.9	23.6	23.5	23.5	23.7	26.8	26.8	26.7	26.9	

IDB	AIRFLOW	OUTDOOR AMBIENT TEMPERATURE																							
		65				75				85				95				105				115			
		59	63	67	71	59	63	67	71	59	63	67	71	59	63	67	71	59	63	67	71	59	63	67	71
85	MBh	60.1	60.9	62.6	65.3	59.5	60.4	62.1	64.7	58.0	58.8	60.6	63.2	55.4	56.2	58.0	60.6	52.2	53.1	54.8	57.4	49.3	50.2	51.9	54.5
	S/T	0.92	0.85	0.73	0.6	1.00	0.86	0.74	0.6	1.00	0.88	0.76	0.6	1.00	0.90	0.78	0.6	1.00	0.92	0.80	0.7	1.00	1.00	0.84	0.7
	ΔT	36	33	29	25	36	33	29	25	36	34	30	26	36	33	29	25	35	33	29	25	37	34	30	26
	kW	3.66	3.66	3.65	3.7	4.11	4.11	4.10	4.1	4.61	4.61	4.60	4.6	5.15	5.15	5.14	5.2	5.75	5.75	5.74	5.8	6.46	6.46	6.45	6.5
	Amps	13.7	13.7	13.7	13.8	15.8	15.8	15.7	15.9	18.1	18.1	18.0	18.2	20.5	20.5	20.5	20.6	23.3	23.3	23.2	23.4	26.5	26.5	26.5	26.6
	MBh	62.9	63.7	65.5	68.1	62.4	63.2	65.0	67.6	60.9	61.7	63.4	66.1	58.3	59.1	60.8	63.5	55.1	55.9	57.7	60.3	52.2	53.0	54.7	57.4
	S/T	1.00	0.89	0.77	0.6	1.00	0.89	0.77	0.6	1.00	0.92	0.80	0.7	1.00	0.93	0.81	0.7	1.00	0.95	0.83	0.7	1.00	1.00	0.88	0.8
	ΔT	33	31	27	23	33	31	27	23	33	31	27	23	33	31	27	23	33	30	26	22	34	32	28	24
	kW	3.71	3.71	3.70	3.74	4.16	4.16	4.15	4.18	4.66	4.65	4.65	4.68	5.20	5.19	5.19	5.22	5.80	5.80	5.79	5.82	6.51	6.50	6.50	6.53
	Amps	14.0	13.9	13.9	14.1	16.0	16.0	16.0	16.1	18.3	18.3	18.2	18.4	20.8	20.7	20.7	20.9	23.5	23.5	23.5	23.6	26.7	26.7	26.7	26.9
MBh	64.9	65.8	67.5	70.1	64.4	65.2	67.0	69.6	62.9	63.7	65.5	68.1	60.3	61.1	62.9	65.5	57.1	57.9	59.7	62.3	54.2	55.0	56.8	59.4	
S/T	1.00	0.86	0.74	0.6	1.00	0.86	0.74	0.6	1.00	0.89	0.76	0.6	1.00	0.90	0.78	0.7	1.00	1.00	0.80	0.7	1.00	1.00	0.85	0.7	
ΔT	32	30	26	21	32	30	26	21	32	30	26	22	32	30	26	21	31	29	25	21	33	31	27	22	
kW	3.73	3.73	3.72	3.8	4.18	4.18	4.17	4.2	4.68	4.67	4.67	4.7	5.22	5.21	5.21	5.2	5.82	5.82	5.81	5.8	6.53	6.52	6.52	6.5	
Amps	14.1	14.0	14.0	14.2	16.1	16.1	16.0	16.2	18.4	18.4	18.3	18.5	20.8	20.8	20.8	21.0	23.6	23.6	23.6	23.7	26.8	26.8	26.8	26.9	

IDB: Entering Indoor Dry Bulb Temperature
 High and low pressures are measured at the liquid and suction service valves.
 Shaded area reflects AHRI conditions
 kW = Total system power
 Amps = outdoor unit amps (comp.+fan)

PERFORMANCE DATA

ALXS4NA1810*/CAPTA2422*				
CONDITIONS: 80 °F IBD, 67 °F IWB @ 625 CFM				
OUTDOOR TEM. ° F.	TOTAL BTU/H	SENSIBLE BTU/H	LATENT BTU/H	TOTAL WATTS
75	18,870	12,260	6,610	1,240
80	18,635	12,320	6,315	1,305
85	18,400	12,380	6,020	1,370
90	18,000	12,265	5,735	1,440
95	17,600	12,150	5,450	1,510
100	17,110	11,975	5,135	1,590
105	16,620	11,800	4,820	1,670
110	16,170	11,850	4,320	1,765
115	15,720	11,900	3,820	1,860
TVA CONDITIONS @ 95° OD DB, 75° ID DB 63° ID WB				
95°	16,970	11,870	5,100	1,520

ALXS4NA2410*/CAPTA2422*				
CONDITIONS: 80 °F IBD, 67 °F IWB @ 700 CFM				
OUTDOOR TEM. ° F.	TOTAL BTU/H	SENSIBLE BTU/H	LATENT BTU/H	TOTAL WATTS
75	25,310	17,160	8,150	1,640
80	24,995	17,240	7,755	1,735
85	24,680	17,320	7,360	1,830
90	24,140	17,160	6,980	1,930
95	23,600	17,000	6,600	2,030
100	22,940	16,760	6,180	2,145
105	22,280	16,520	5,760	2,260
110	21,680	16,585	5,095	2,395
115	21,080	16,650	4,430	2,530
TVA CONDITIONS @ 95° OD DB, 75° ID DB 63° ID WB				
95°	22,760	16,610	6,150	2,030

ALXS4NA3010*/CAPTA3026*				
CONDITIONS: 80 °F IBD, 67 °F IWB @ 950 CFM				
OUTDOOR TEM. ° F.	TOTAL BTU/H	SENSIBLE BTU/H	LATENT BTU/H	TOTAL WATTS
75	30,670	21,430	9,240	2,000
80	30,290	21,530	8,760	2,110
85	29,910	21,630	8,280	2,220
90	29,255	21,430	7,825	2,340
95	28,600	21,230	7,370	2,460
100	27,800	20,930	6,870	2,595
105	27,000	20,630	6,370	2,730
110	26,270	20,715	5,555	2,890
115	25,540	20,800	4,740	3,050
TVA CONDITIONS @ 95° OD DB, 75° ID DB 63° ID WB				
95°	27,580	20,750	6,830	2,460

ALXS4NA3610*/CAPTA3626*				
CONDITIONS: 80 °F IBD, 67 °F IWB @ 1138 CFM				
OUTDOOR TEM. ° F.	TOTAL BTU/H	SENSIBLE BTU/H	LATENT BTU/H	TOTAL WATTS
75	36,670	26,080	10,590	2,380
80	36,215	26,205	10,010	2,515
85	35,760	26,330	9,430	2,650
90	34,980	26,085	8,895	2,795
95	34,200	25,840	8,360	2,940
100	33,245	25,475	7,770	3,105
105	32,290	25,110	7,180	3,270
110	31,420	25,215	6,205	3,460
115	30,550	25,320	5,230	3,650
TVA Conditions @ 95° OD DB, 75° ID DB 63° ID WB				
95°	32,980	25,250	7,730	2,950

ALXS4NA4210*/CAPTA4230*				
CONDITIONS: 80 °F IBD, 67 °F IWB @ 1435 CFM				
OUTDOOR TEM. ° F.	TOTAL BTUH	SENSIBLE BTUH	LATENT BTUH	TOTAL WATTS
75	42,890	31,170	11,720	2,800
80	42,360	31,315	11,045	2,955
85	41,830	31,460	10,370	3,110
90	40,915	31,170	9,745	3,275
95	40,000	30,880	9,120	3,440
100	38,885	30,440	8,445	3,630
105	37,770	30,000	7,770	3,820
110	36,750	30,125	6,625	4,040
115	35,730	30,250	5,480	4,260
TVA Conditions @ 95° OD DB, 75° ID DB 63° ID WB				
95°	38,570	30,180	8,390	3,450

ALXS4NA4810*/CAPT6030*				
CONDITIONS: 80 °F IBD, 67 °F IWB @ 1400 CFM				
OUTDOOR TEM. ° F.	TOTAL BTUH	SENSIBLE BTUH	LATENT BTUH	TOTAL WATTS
75	48,790	33,230	15,560	3,160
80	48,185	33,385	14,800	3,340
85	47,580	33,540	14,040	3,520
90	46,540	33,230	13,310	3,720
95	45,500	32,920	12,580	3,920
100	44,230	32,455	11,775	4,140
105	42,960	31,990	10,970	4,360
110	41,800	32,120	9,680	4,620
115	40,640	32,250	8,390	4,880
TVA Conditions @ 95° OD DB, 75° ID DB 63° ID WB				
95°	43,880	32,170	11,710	3,920

ALXS4NA6010*/CAPTA6030*				
CONDITIONS: 80 °F IBD, 67 °F IWB @ 1500 CFM				
OUTDOOR TEM. ° F.	TOTAL BTUH	SENSIBLE BTUH	LATENT BTUH	TOTAL WATTS
75	61,120	39,380	21,740	4,090
80	60,360	39,565	20,795	4,340
85	59,600	39,750	19,850	4,590
90	58,300	39,380	18,920	4,860
95	57,000	39,010	17,990	5,130
100	55,410	38,460	16,950	5,430
105	53,820	37,910	15,910	5,730
110	52,365	38,065	14,300	6,085
115	50,910	38,220	12,690	6,440
TVA Conditions @ 95° OD DB, 75° ID DB 63° ID WB				
95°	54,970	38,130	16,840	5,130

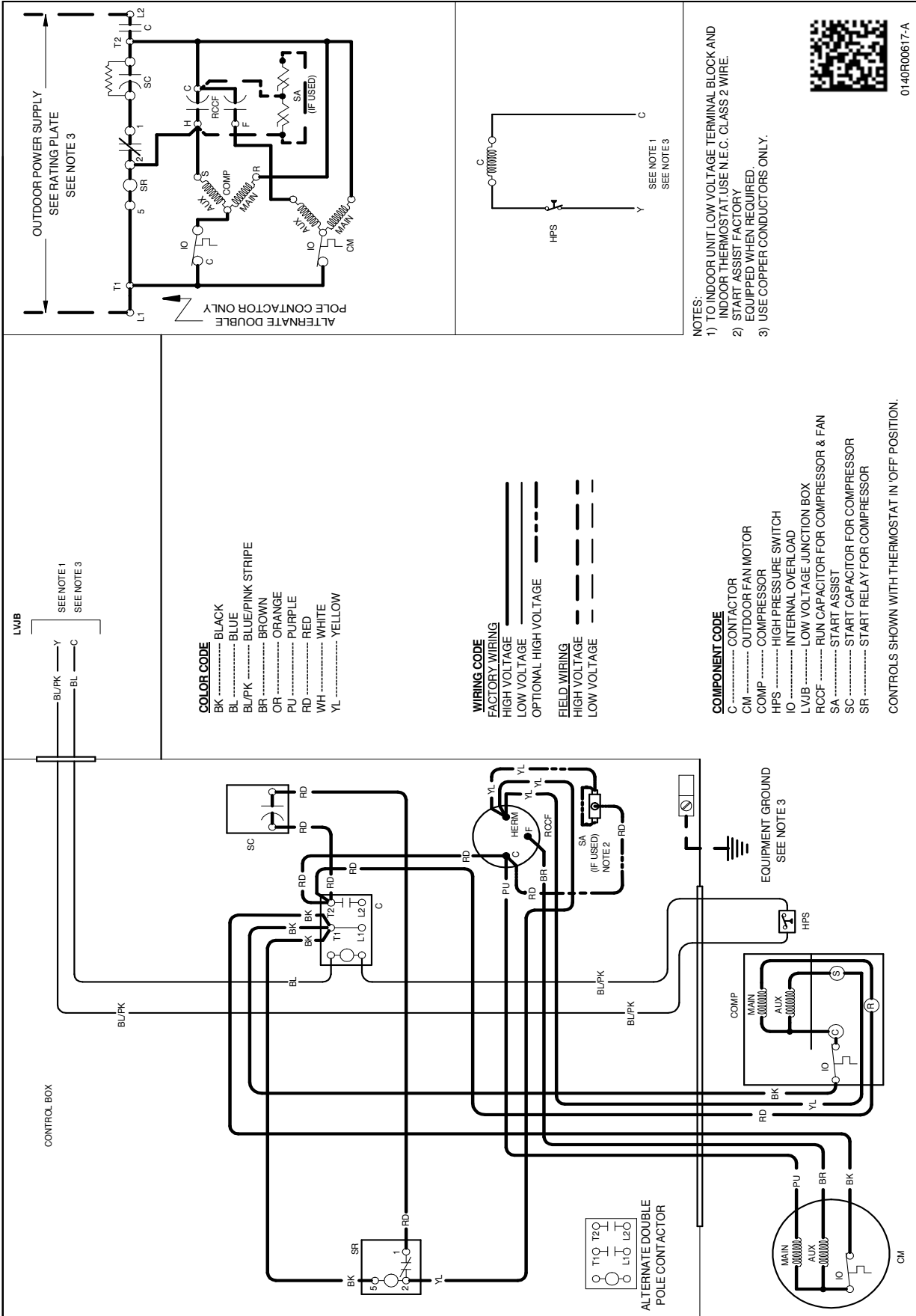

WARNING

High Voltage: Disconnect all power before servicing or installing this unit. Multiple power sources may be present. Failure to do so may cause property damage, personal injury, or death.

Wiring is subject to change. Always refer to the wiring diagram or the unit for the most up-to-date wiring.

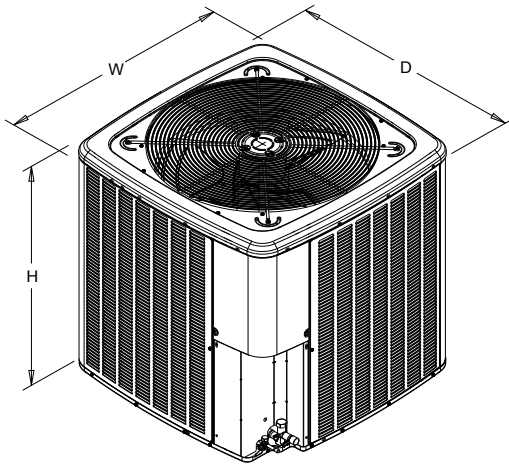

MODEL	DIMENSIONS		
	W"	D"	H"
ALXS4NA1810A*	26	26	27
ALXS4NA2410A*	26	26	27
ALXS4NA3010A*	29	29	32
ALXS4NA3610A*	29	29	39½
ALXS4NA4210A*	35½	35½	35¾
ALXS4NA4810A*	35½	35½	35¾
ALXS4NA6010A*	35½	35½	39¾

ACCESSORIES

Model	Description	ALXS4N A1810A*	ALXS4N A2410A*	ALXS4N A3010A*	ALXS4N A3610A*	ALXS4N A4210A*	ALXS4N A4810A*	ALXS4N A6010A*
ABK-20	Anchor Bracket Kit ^	X	X	X	X	X	X	X
ASC01A	Anti-Short Cycle Kit	X	X	X	X	X	X	X
Factory Installed Hard-start Kit		X	X	X				
CSR-U-1	Hard-start Kit				X	X	X	X
FSK01A ¹	Freeze Protection Kit	X	X	X	X	X	X	X
LSK02A ²	Liquid Line Solenoid Kit	X	X	X	X	X	X	X
LAKT01	Low-Ambient Kit	X	X	X	X	X	X	
0130R00000S	Low-Pressure Switch Kit	X	X	X	X	X	X	X

⁰ Contains 20 brackets; four brackets needed to anchor unit to pad

¹ Installed on indoor coil

² Condensing units and heat pumps with reciprocating or rotary compressors require the use of start-assist components when used in conjunction with an indoor coil using a non-bleed thermal expansion valve refrigerant metering device or liquid line solenoid kit. The TXV should always be sized based on the tonnage of the outdoor unit.

All AHRI system ratings are accessible in the System Configurator tool via PartnerLink.

