

HEATING INPUT: 60,000–100,000 BTU/H

TWO-STAGE, VARIABLE-SPEED
 ECM GAS FURNACE
 80% AFUE



Contents

Nomenclature.....	2
Product Specifications.....	3
Dimensions	5
Airflow Data	7
Accessories	8
Wiring Diagram	10



Standard Features

- Integrated communicating ComfortBridge™ technology
- Two-stage gas valve provides quiet, economical heating
- Commissioning and diagnostics via on board Bluetooth with the CoolCloud™ phone and tablet application
- Efficient and quiet variable-speed ECM circulator motor gently ramps up or down according to heating or cooling demand
- SureStart® Silicon Nitride igniter designed for long igniter life
- Self-diagnostic control board with constant memory fault code history output to a triple 7-segment display
- Low constant fan speed circulates air throughout the home
- Quiet, two-speed induced draft blower
- California Low NOx emissions-compliant models available
- Can no longer be installed in California's South Coast Air Quality Management District (SCAQMD) on or after October 1, 2019.
- AHRI Certified; ETL Listed

Cabinet Features

- Fully insulated, heavy-gauge steel cabinet with durable baked-enamel finish
- Multi-position installation:
 AMVC80: upflow, horizontal left or right
 ACVC80: downflow, horizontal left or right
- Removable bottom for side- or bottom-return applications
- Convenient left or right connection for gas/electric service
- Cabinet air leakage ≤ 2%
- Coil and furnace fit flush for most installations



* Complete warranty details available from your local dealer or at www.amana-hac.com. To receive the Lifetime Unit Replacement Limited Warranty (good for as long as you own your home) and 10-Year Parts Limited Warranty, online registration must be completed within 60 days of installation. Online registration is not required in California or Québec. The duration of warranty coverage in Texas and Florida differs in some cases.

NOMENCLATURE

	A	M	V	C	80	040	4	C	*	**	
	1	2	3	4	5,6	7,8,9	10	11	12	13,14	
BRAND A - Amana® Brand											ENGINEERING Major /Minor Revisions * Not used for inventory control.
CONFIGURATION M - Upflow/Horizontal C - Downflow/Horizontal											NOx N - Natural Gas X - Low NOx
MOTOR V - Variable Speed ECM / ComfortBridge™ E - Multi-Speed ECM S - Single Speed											CABINET WIDTH A - 14" C - 21" B - 17½" D - 24½"
GAS VALVE M - Modulating S - Single Stage C - Two Stage											MAXIMUM CFM 2 - 800 CFM 4 - 1600 CFM 3 - 1200 CFM 5 - 2000 CFM
AFUE 80 - 80% AFUE											MBTU/h 040 - 40,000 BTU/h 100 - 100,000 BTU/h 060 - 60,000 BTU/h 120 - 120,000 BTU/h 080 - 80,000 BTU/h

	AMVC80 0603B*A	AMVC80 0604B*A	AMVC80 0803B*A	AMVC80 0804C*A	AMVC80 0805C*A	AMVC80 0805D*A	AMVC80 1005C*A
HEATING CAPACITY							
High Fire Input (BTU/h) ¹	60,000	60,000	80,000	80,000	80,000	80,000	100,000
High Fire Output (BTU/h) ¹ :							
Natural Gas	48,000	48,000	64,000	64,000	64,000	64,000	80,000
LP Gas	48,000	48,000	64,000	64,000	64,000	64,000	80,000
Low Fire Input (BTU/h) ¹	42,000	42,000	56,000	56,000	56,000	56,000	70,000
Low Fire Output (BTU/h) ¹ :							
Natural Gas	33,600	33,600	44,800	44,800	44,800	44,800	56,000
LP Gas	33,600	33,600	44,800	44,800	44,800	44,800	56,000
AFUE ²	80	80	80	80	80	80	80
Available AC @ 0.5" ESP	1.5 - 3.0	1.5 - 4.0	1.5 - 3.0	3.0 - 4.0	2.0 - 5.0	2.5 - 5.0	2.0 - 5.0
Temp Rise Range (° F) Low/High Fire	15-45 / 15-45	20-50 / 20-50	30-60 / 30-60	25-55 / 25-55	20-50 / 20-50	20-50 / 20-50	25-55 / 25-55
CIRCULATOR BLOWER							
Size (D x W)	10" x 8"	10" x 8"	10" x 8"	11" x 10"	10" x 10"	11" x 10"	10" x 10"
Horsepower - RPM	1/2	3/4	1/2	1/2	3/4	3/4	3/4
Speed	Variable ECM	Variable ECM	Variable ECM	Variable ECM	Variable ECM	Variable ECM	Variable ECM
Vent Diameter ¹	4"	4"	4"	4"	4"	4"	4"
No. of Burners	3	3	4	4	4	4	5
ELECTRICAL DATA							
Min. Circuit Ampacity ³	7.75	10.6	7.75	7.75	10.6	10.6	10.6
Max. Overcurrent Device (amps) ⁴	15	15	15	15	15	15	15
SHIP WEIGHT (LBS)							
	105	107	110	118	121	129	124

¹ Natural Gas BTU/h; for altitudes above from 0' to 4,500' above sea level, reduce input rating 4% for each 1,000' above 4,500' altitude. Low-fire rate is 70% of high-fire rate.

² DOE AFUE based upon Isolated Combustion System (ICS)

³ Minimum Circuit Ampacity = (1.25 x Circulator Blower Amps) + ID Blower amps. Wire size should be determined in accordance with National Electrical Codes. Extensive wire runs will require larger wire sizes.

⁴ Maximum Overcurrent Protection Device refers to maximum recommended fuse or circuit breaker size. May use fuses or HACR-type circuit breakers of the same size as noted.

NOTES

- All furnaces are manufactured for use on 115 VAC, 60 Hz, single-phase electrical supply.
- Gas Service Connection ½" FPT
- Important: Size fuses and wires properly and make electrical connections in accordance with the National Electrical Code and/or all existing local codes.

SPECIFICATIONS

	ACVC80 0603B*A	ACVC80 0803B*A	ACVC80 0805C*A	ACVC80 1005C*A
HEATING CAPACITY				
High Fire Input (BTU/h) ¹	60,000	80,000	80,000	100,000
High Fire Output (BTU/h) ¹				
Natural Gas	48,000	64,000	64,000	80,000
LP Gas	48,000	64,000	64,000	80,000
Low Fire Input (BTU/h) ¹	42,000	56,000	56,000	70,000
Low Fire Output (BTU/h) ¹				
Natural Gas	33,600	44,800	44,800	56,000
LP Gas	33,600	44,800	44,800	56,000
AFUE ²	80	80	80	80
Available AC @ 0.5" ESP	1.5 - 3.0	1.5 - 3.0	2.0 - 5.0	2.0 - 5.0
Temp Rise Range (° F) Low/High Fire	25-55 / 25-55	30-60 / 30-60	25-55 / 25-55	20-50 / 20-50
CIRCULATOR BLOWER				
Size (D x W)	10" x 8"	10" x 8"	10" x 10"	10" x 10"
Horsepower - RPM	1/2	1/2	3/4	3/4
Speed	Variable ECM	Variable ECM	Variable ECM	Variable ECM
Vent Diameter ²	4"	4"	4"	4"
No. of Burners	3	4	4	5
ELECTRICAL DATA				
Min. Circuit Ampacity ³	7.75	7.75	10.6	10.6
Max. Overcurrent Device (amps) ⁴	15	15	15	15
SHIP WEIGHT (LBS)				
	105	109	125	129

¹ Natural Gas BTU/h; for altitudes above from 0' to 4,500' above sea level, reduce input rating 4% for each 1,000' above 4,500' altitude. Low-fire rate is 70% of high-fire rate.

² DOE AFUE based upon Isolated Combustion System (ICS)

³ Minimum Circuit Ampacity = (1.25 x Circulator Blower Amps) + ID Blower amps. Wire size should be determined in accordance with National Electrical Codes. Extensive wire runs will require larger wire sizes.

⁴ Maximum Overcurrent Protection Device refers to maximum recommended fuse or circuit breaker size. May use fuses or HACR-type circuit breakers of the same size as noted.

NOTES

- All furnaces are manufactured for use on 115 VAC, 60 Hz, single-phase electrical supply.
- Gas Service Connection ½" FPT
- Important: Size fuses and wires properly and make electrical connections in accordance with the National Electrical Code and/or all existing local codes.

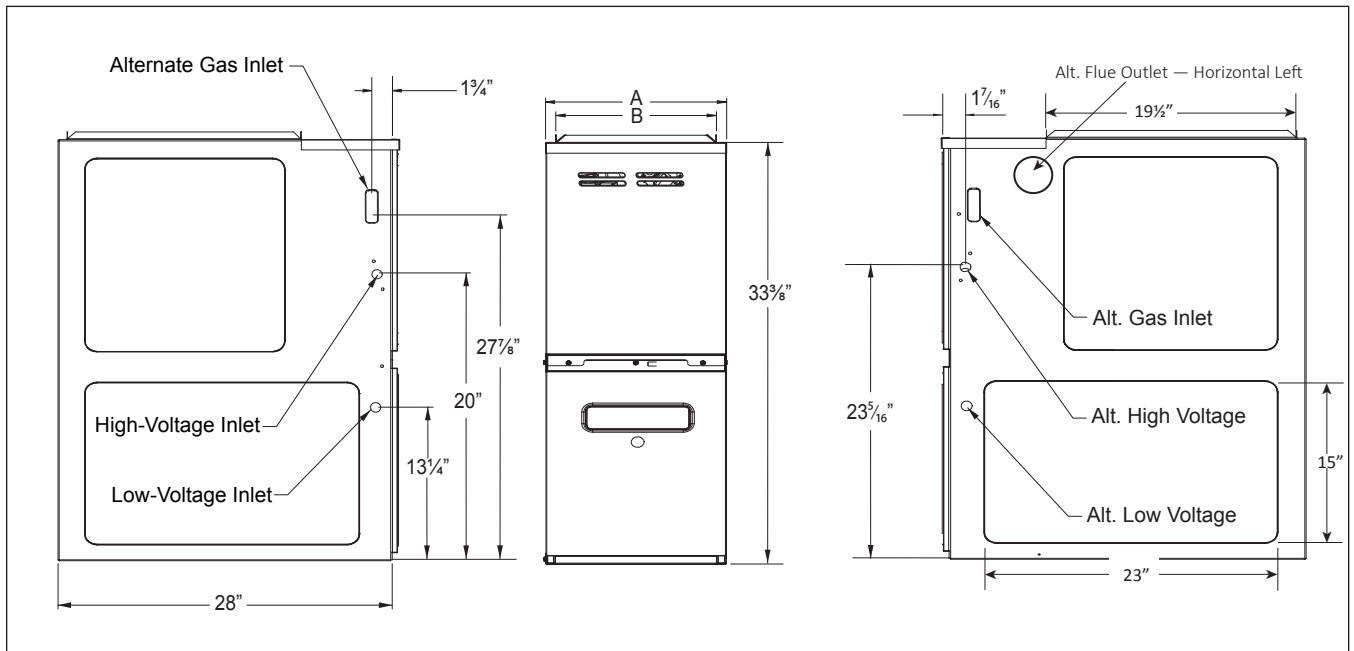

MODEL	DIMENSIONS			HEIGHTS	
	W	D	H	A	B
AMVC800603B**	17½"	28"	33⅜"	17½"	16"
AMVC800604B**	17½"	28"	33⅜"	17½"	16"
AMVC800803B**	17½"	28"	33⅜"	17½"	16"
AMVC800804C**	21"	28"	33⅜"	21"	19½"
AMVC800805C**	21"	28"	33⅜"	21"	19½"
AMVC800805D**	24½"	28"	33⅜"	24½"	23"
AMVC801005C**	21"	28"	33⅜"	21"	19½"

MINIMUM CLEARANCES TO COMBUSTIBLE MATERIALS

SIDES	REAR	FRONT	BOTTOM	VENT		TOP
				SW	B	
1	0	3	C	6	1	1

C = If placed on combustible floor, the floor MUST be wood ONLY.

NOTES:

- For servicing or cleaning, a 24" front clearance is recommended.
- Unit connections (electrical, flue, and drain) may necessitate greater clearances than the minimum clearances listed above.
- In all cases, accessibility clearance must take precedence over clearances from the enclosure where accessibility clearances are greater.
- Refer to the appropriate USA and Canadian codes:
 - In the USA: the National Fuel Gas Code NFPA 54 / ANSI Z223.1
 - In Canada: the Canada National Standard of Canada, CAN/CSA B149.1 and CAN/CSA B142.2

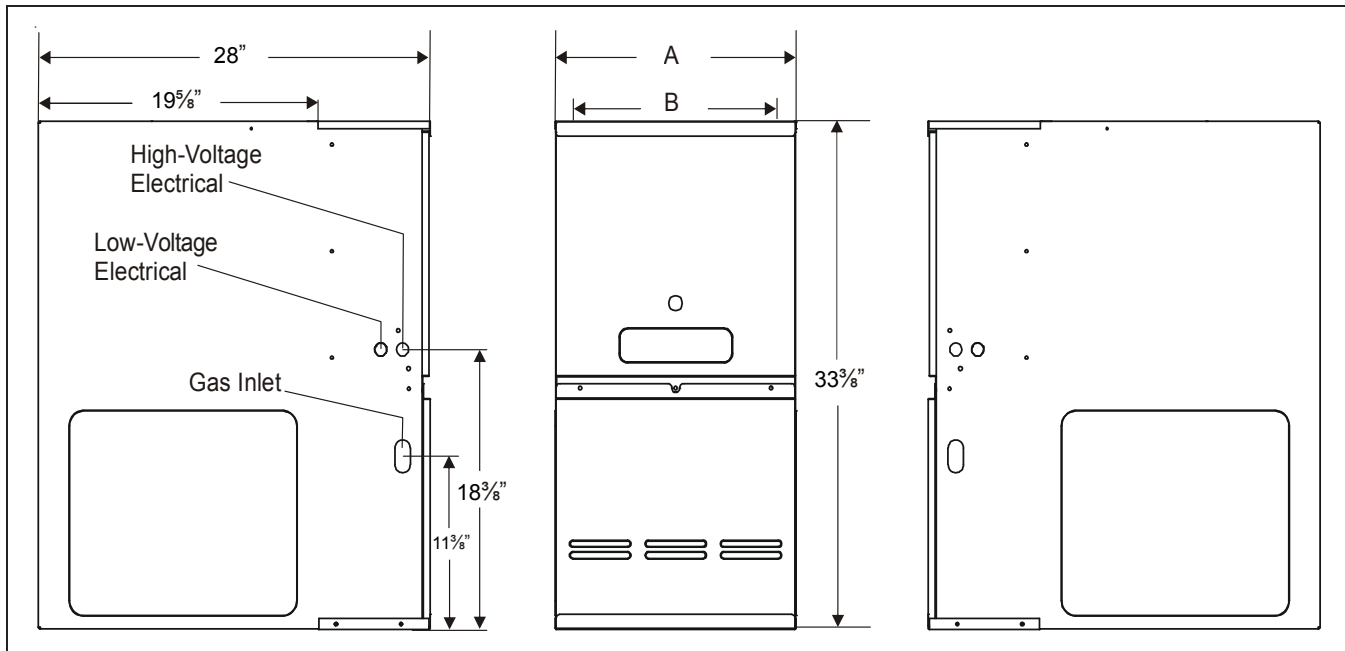

MODEL	DIMENSIONS			HEIGHTS	
	W	D	H	A	B
ACVC800603B**	17½"	28"	33⅜"	17½"	16"
ACVC800803B**	17½"	28"	33⅜"	17½"	16"
ACVC800805C**	21"	28"	33⅜"	21"	19½"
ACVC801005C**	21"	28"	33⅜"	21"	19½"

MINIMUM CLEARANCES TO COMBUSTIBLE MATERIALS

SIDES	REAR	FRONT ¹	VENT ²		TOP
			SW	B	
1	0	3	6	1	1

Approved for line contact in the horizontal position.

¹ 24" clearance for serviceability recommended.

² Single Wall Vent (SW) to be used only as a connector. Refer to the venting tables outlined in the Installation Manual for additional venting requirements.

MODEL/TEMP RISE RANGE (MID RISE)	ACVC800603BXA* 25-55 (40)		ACVC800603BXA* 30-60 (45)		ACVC800805CXA* 25-55 (40)		ACVC801005CXA* 20-50 (35)		AMVC800603B*A* 15-45 (30)		AMVC800604B*A* 20-50 (35)	
	CFM	RISE	CFM	RISE	CFM	RISE	CFM	RISE	CFM	RISE	CFM	RISE
Recommended cfm for high heat / expected temperature rise	1100	40	1325	45	1470	40	2090	35	1400	32	1275	35
Lowest recommended cfm for hi heat / expected temperature rise	810	55	990	60	1070	55	1475	50	980	45	890	50
Maximum cfm for hi heat / expected temperature rise	1400	32	1400	42	2200	27	2200	34	1400	32	1760	25

NOTE: Low Heat CFM = High Heat CFM X .7. Low Heat Temperature Rise Is Expected to Equal High Heat Temperature Rise ± 5% 0140F02402-A

MODEL/TEMP RISE RANGE (MID RISE)	AMVC800803B*A* 30-60 (45)		AMVC800804C*A* 25-55 (40)		AMVC800805C*A* 20-50 (35)		AMVC800805D*A* 20-50 (35)		AMVC801005C*A* 25-55 (40)	
	CFM	RISE	CFM	RISE	CFM	RISE	CFM	RISE	CFM	RISE
Recommended cfm for high heat / expected temperature rise	1330	45	1400	42	1700	35	1700	35	1850	40
Lowest recommended cfm for hi heat / expected temperature rise	980	60	1090	54	1175	50	1175	50	1350	55
Maximum cfm for hi heat / expected temperature rise	1400	42	1760	34	2200	27	2200	27	2200	34

NOTE: Low Heat CFM = High Heat CFM X .7. Low Heat Temperature Rise Is Expected to Equal High Heat Temperature Rise ± 5% 0140F02402-A

**ACVC800603BXA*, ACVC800803BXA*
AMVC800603B*A*, AMVC800803B*A*
COOLING SPEED
(@ .1" - .8" w.c. ESP)**

TONS	HIGH-STAGE	LOW-STAGE CFM
1.5	600	420
2	800	560
2.5	1,000	700
3	1,200	840
MAX	1,400	

**AMVC800604B*A*
AMVC800804C*A*
COOLING SPEED
(@ .1" - .8" w.c. ESP)**

TONS	HIGH-STAGE	LOW-STAGE CFM
2	800	560
2.5	1,000	700
3	1,200	840
4	1,600	1120
MAX	1,760	

**ACVC800805CXA*
ACVC801005CXA*
COOLING SPEED (@ .1" - .8" w.c. ESP)**

TONS	HIGH-STAGE	LOW-STAGE CFM
2	800	560
3	1,200	840
4	1,600	1,120
5	2,000	1,400
MAX	2,000	

**AMVC800805C*A*, AMVC800805D*A*
AMVC801005C*A*
COOLING SPEED
(@ .1" - .8" w.c. ESP)**

TONS	HIGH-STAGE	LOW-STAGE CFM
2	800	560
3	1,200	840
4	1,600	1,120
5	2,000	1,400
MAX	2,200	

All furnaces ship as high speed for cooling. Installer must adjust blower speed as needed.
For most jobs, about 400 CFM per ton when cooling is desirable.
Do not operate above .5" w.c. ESP in heating mode. Operating CFM between .5" and .8" w.c. is tabulated for cooling purposes only.

ACVC CONTINUOUS FAN SPEEDS

MODEL	FURNACE MAXIMUM CFM	CONTINUOUS FAN SPEED
ACVC800603BXA*	1,400	350-1,400
ACVC800803BXA*	1,400	350-1,400
ACVC800805CXA*	2,200	550-2,200
ACVC801005CXA*	2,200	550-2,200

ACVC8 MINIMUM FILTER SIZES

MODEL #	ACVC800603BX, ACVC80803BX	ACVC800805CX	ACVC801005CX
Filter Size (in ²)	(2) 10 x 20 or (1) 16 x 25 (Top Return)	(2) 14 x 20 or (1) 20 x 25 (Top Return)	

Note: Other size filters of equal or greater surface area may be used; filters may also be centrally located.

¹ Use 2 - 16 X 25 filters on side returns or 20 X 25 filter on bottom return if furnace is connected to a cooling unit over 4 tons nominal capacity.

AMVC CONTINUOUS FAN SPEEDS

MODEL	FURNACE MAXIMUM CFM	CONTINUOUS FAN SPEED
AMVC800603B*A	1400	350 - 1400
AMVC800604B*A	1760	440 - 1760
AMVC800803B*A	1400	350 - 1400
AMVC800804C*A	1760	440 - 1760
AMVC800805C*A	2200	550 - 2200
AMVC800805D*A	2200	550 - 2200
AMVC801005C*A	2200	550 - 2200

AMVC8 MINIMUM FILTER SIZES

MODEL #	AMVC800604B*, AMVC800603B*, AMVC800803B*	AMVC800805C*, AMVC800804C*, AMVC800805D*	AMVC801005C*
Filter Size (in ²)	(1) 16 x 25 (Side or Bottom)	(1) 16 x 25 (Side or Bottom) ¹	(2) 16 x 25 (Side) or (1) 20 x 25 (Bottom)

Note: Other size filters of equal or greater surface area may be used; filters may also be centrally located.

¹ Use 2 - 16 X 25 filters on side returns or 20 X 25 filter on bottom return if furnace is connected to a cooling unit over 4 tons nominal capacity.

ACCESSORIES

MODEL	DESCRIPTION	AMVC80 0603B*	AMVC80 0604B*	AMVC80 0803B*	AMVC80 0804C*	AMVC80 0805C*	AMVC80 0805D*
AFE18-60A	Fossil Fuel (Dual Fuel) Kit	√	√	√	√	√	√
HA-02	High-Altitude Natural Gas Kit	√	√	√	√	√	√
LPLP03	Low LP Gas Pressure Switch	√	√	√	√	√	√
LPM-06	LP Conversion Kits	√	√	√	√	√	√

MODEL	DESCRIPTION	ACVC80 0603B*	ACVC80 0803B*	ACVC80 0805C*	ACVC80 1005C*
SBT17	Downflow Sub-Base 17.5"	√	√	—	—
SBT21	Downflow Sub-Base 21"	—	—	√	√
AFE18-60A	Fossil Fuel (Dual Fuel) Kit	√	√	√	√
HA-02	High-Altitude Natural Gas Kit	√	√	√	√
LPLP03	Low LP Gas Pressure Switch	√	√	√	√
LPM-06	LP Conversion Kits	√	√	√	√

