

## WALL-MOUNT AIR HANDLER 1½ TO 3 TONS

### Contents

Nomenclature .....	2
Accessories .....	2
Product Specifications .....	3
Dimensions .....	5
Airflow Data .....	7
Wiring Diagram .....	8



### Product Features

- AWST Models: Equipped with a fully adjustable TXV
- Direct-drive, multi-speed motors allows air volume variation for heating/cooling
- Sequence-controlled, rust-resistant nickel chromium heating elements of 3, 5, 8, and 10 kW
- Aluminum tubing coils on all models
- Cabinet air leakage less than 2.0% at 1.0 inch H<sub>2</sub>O when tested in accordance with ASHRAE standard 193
- UL 60335 2-40 Compliant
- Cabinet air leakage less than 1.4% at 0.5 inch H<sub>2</sub>O when tested in accordance with ASHRAE standard 193
- Factory-installed pull-type disconnect
- Thermoplastic drain pan with bottom primary and secondary drain connections
- Built-in filter rack (filter included)
- Large chassis (2½- and 3-ton units) – front return only
- Small chassis (1½- and 2-ton units) – front or bottom return
- Wall-hanging bracket provided
- AHRI Certified; ETL Listed



\* Complete warranty details available from your local dealer or at [www.daikincomfort.com](http://www.daikincomfort.com). To receive the 12-Year Parts Limited Warranty, online registration must be completed within 60 days of installation. Additional requirements for annual maintenance are required for the Unit Replacement Limited Warranty. Online registration and some of the additional requirements are not required in California or Québec. The duration of warranty coverage in Texas and Florida differs in some cases.

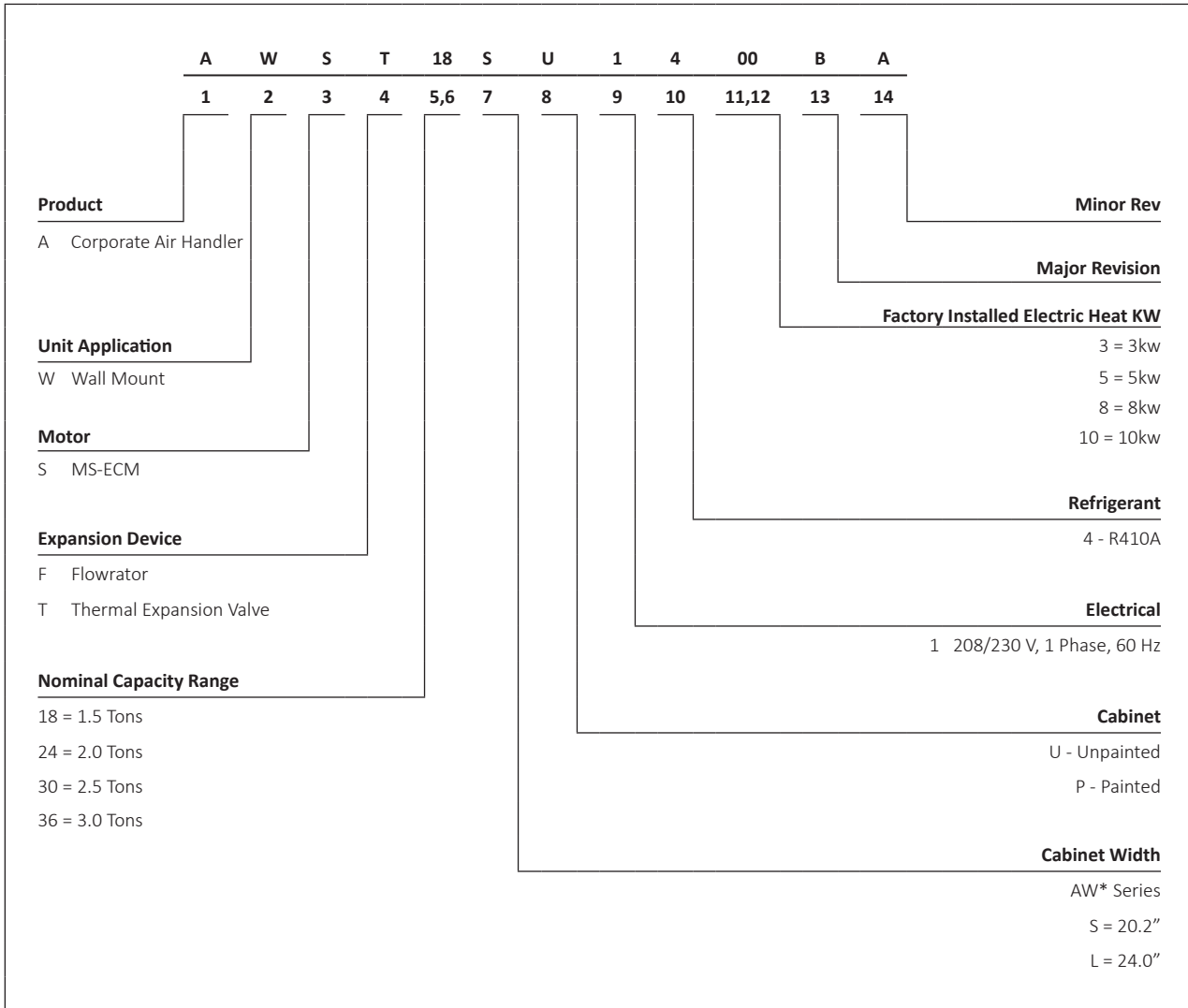

**ACCESSORIES**

MODEL	ITEM #	DESCRIPTION
AWST18-AWST24	Wad-1	Wall access door
AWST30-AWST36	Wad-2	Wall access door

	AWST18 SU1403 BA	AWST18 SU1405 BA	AWST18S U1410 BA	AWST24 SU1405 BA	AWST24 SU1408 BA	AWST24 SU1410 BA
<b>NOMINAL RATINGS</b>						
Cooling (BTU/h)	18,000	18,000	18,000	24,000	24,000	24,000
Electric Heat (kW)	3	5	8	5	8	10
<b>BLOWER</b>						
Diameter	10	10	10	10	10	10
Width	6	6	6	6	6	6
<b>COIL CONNECTIONS</b>						
Liquid	3/8"	3/8"	3/8"	3/8"	3/8"	3/8"
Suction	5/8"	5/8"	5/8"	5/8"	5/8"	5/8"
Coil Drain Connection (FPT)	3/4"	3/4"	3/4"	3/4"	3/4"	3/4"
<b>ELECTRICAL DATA</b>						
Voltage	208/230	208/230	208/230	208/230	208/230	208/230
Minimum Circuit Ampacity	17/18.9	24.9/28	36/41.3	24.9/28	36/41.3	47.5/54
Max. Overcurrent Device (Amps)	20/20	25/30	40/45	25/30	40/45	50/60
Minimum VAC	197	197	197	197	197	197
Maximum VAC	253	253	253	253	253	253
Minimum VAC	197	197	197	197	197	197
<b>BLOWER MOTOR</b>						
Full Load Amps (FLA)	2.6	2.6	2.6	2.6	2.6	2.6
Horsepower (HP)	1/3	1/3	1/3	1/3	1/3	1/3
<b>SHIP WEIGHT (LBS)</b>	84	84	84	84	84	84

PRODUCT SPECIFICATIONS (CONTD.)

	AWST30 LU1405 BA	AWST30 LU1408 BA	AWST30 LU1410 BA	AWST36 LU1405 BA	AWST36 LU1408 BA	AWST36 LU1410 BA
<b>NOMINAL RATINGS</b>						
Cooling (BTU/h)	30,000	30,000	30,000	36,000	36,000	36,000
Electric Heat (kW)	5	8	10	5	8	10
<b>BLOWER</b>						
Diameter	10	10	10	10	10	10
Width	8	8	8	8	8	8
<b>COIL CONNECTIONS</b>						
Liquid	3/8"	3/8"	3/8"	3/8"	3/8"	3/8"
Suction	3/4"	3/4"	3/4"	3/4"	3/4"	3/4"
Coil Drain Connection (FPT)	3/4"	3/4"	3/4"	3/4"	3/4"	3/4"
<b>ELECTRICAL DATA</b>						
Voltage	208/230	208/230	208/230	208/230	208/230	208/230
Minimum Circuit Ampacity	26/29.8	37.8/43	49/55.8	26/29.8	37.8/43	49/55.8
Max. Overcurrent Device (Amps)	30/30	40/45	50/60	30/30	40/45	50/60
Minimum VAC	197	197	197	197	197	197
Maximum VAC	253	253	253	253	253	253
Minimum VAC	197	197	197	197	197	197
<b>BLOWER MOTOR</b>						
Full Load Amps (FLA)	3.9	3.9	3.9	3.9	3.9	3.9
Horsepower (HP)	1/2	1/2	1/2	1/2	1/2	1/2
<b>SHIP WEIGHT (LBS)</b>						
	109	109	109	109	109	109

**Note** - Once installed, top of unit must be level or slightly tilted back to ensure proper condensate drainage.

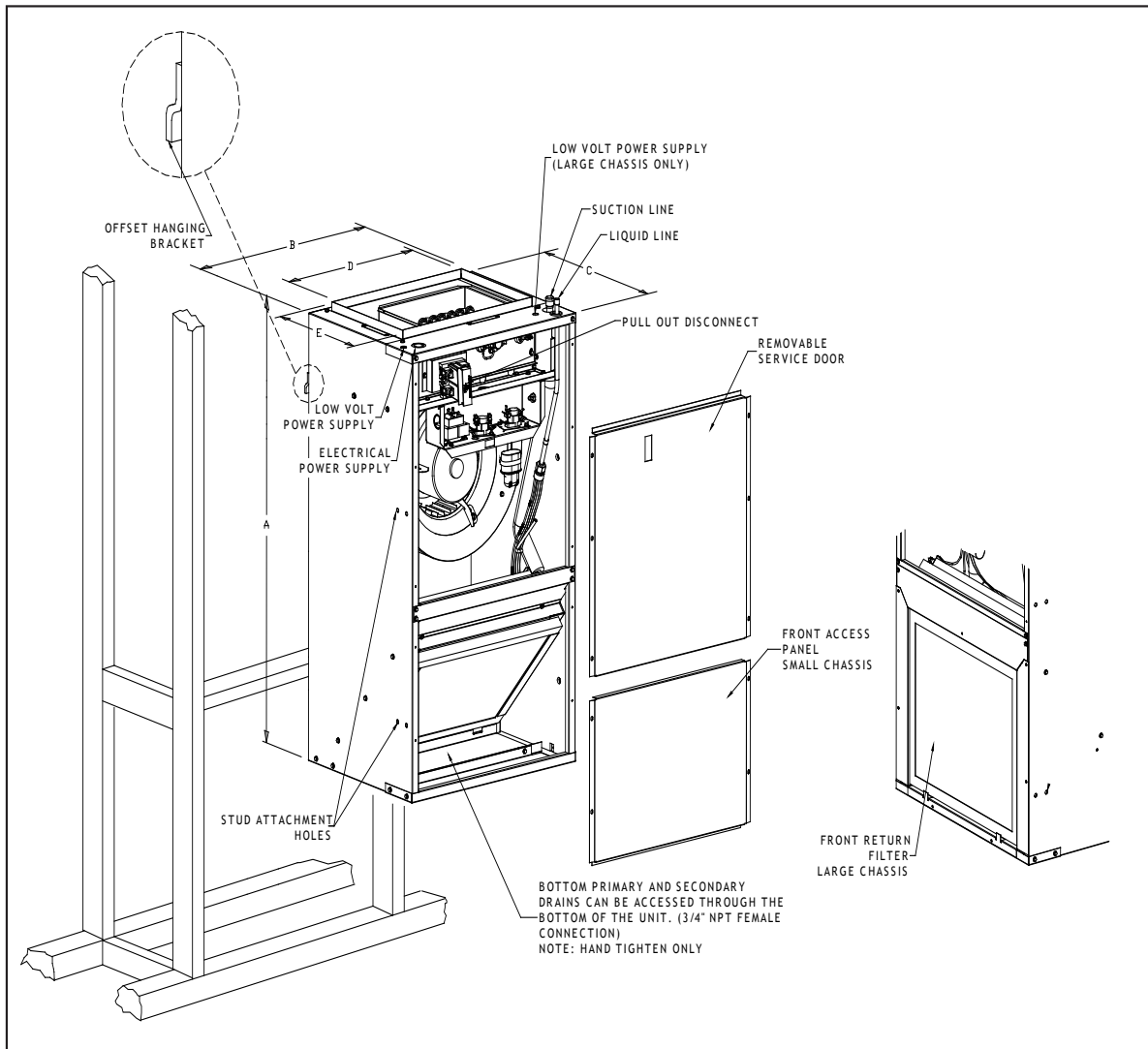

SMALL CHASSIS (AWST18-24)	
A	36"
B	20 <sup>3</sup> / <sub>16</sub> "
C	16 <sup>7</sup> / <sub>8</sub> "
D	16"
E	11"
Filter	14" x 18" x 1"

LARGE CHASSIS (AWST30-36)	
A	36"
B	24"
C	21"
D	19 <sup>7</sup> / <sub>8</sub> "
E	15 <sup>7</sup> / <sub>8</sub> "
Filter (30, 36, 31, 32, 37)	18" x 20" x 1"

DIMENSIONS (CONTD.)

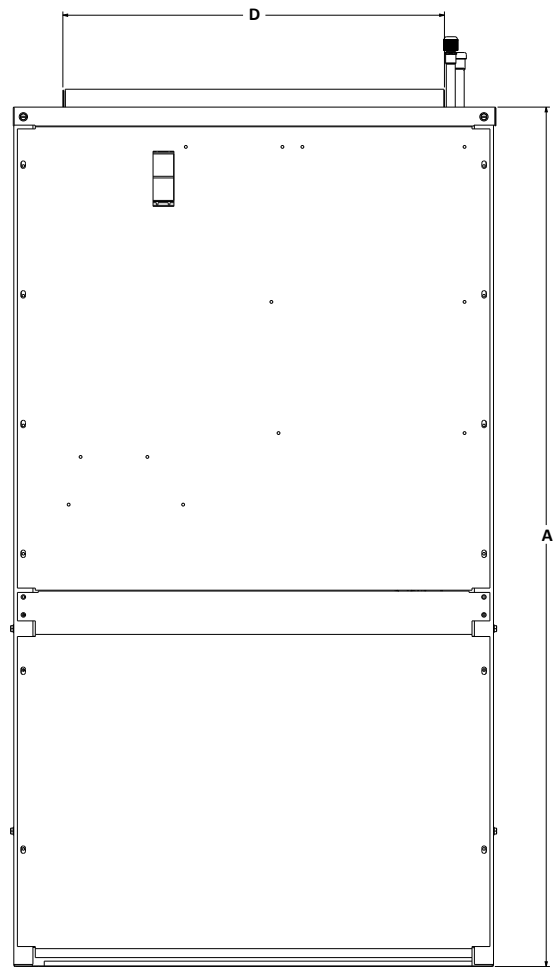
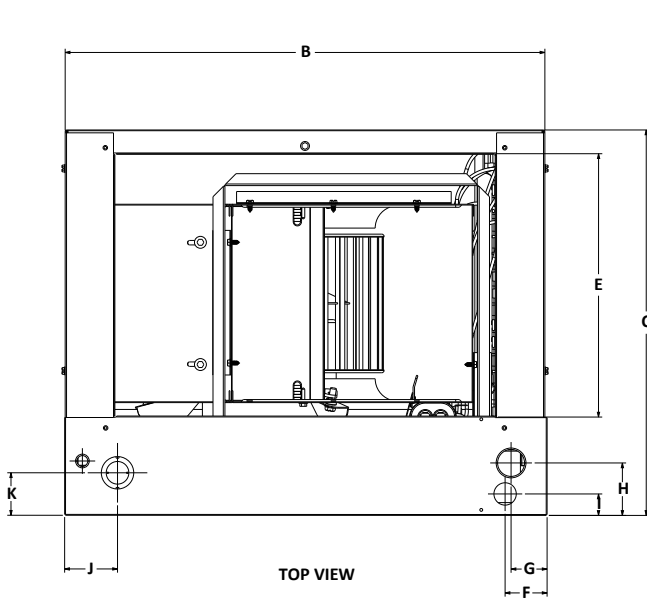

FRESH AIR OPENINGS

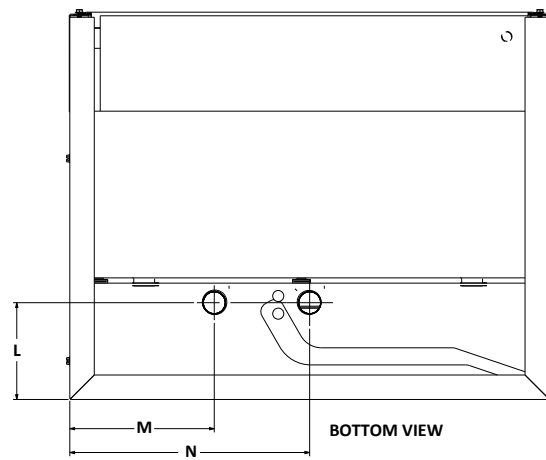
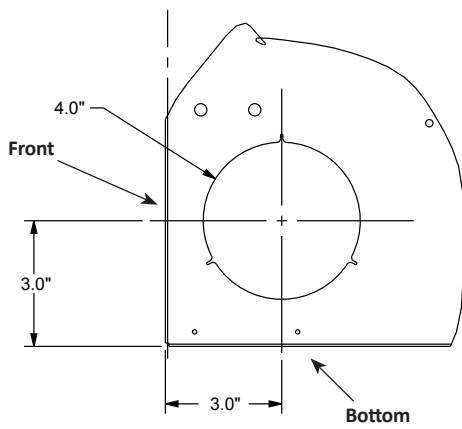

	A	B	C	D	E	F	G	H	I	J	K	L	M	N
AWST 18-24	36"	20 $\frac{1}{4}$ "	16 $\frac{1}{8}$ "	16"	11"	1 $\frac{3}{4}$ "	1 $\frac{1}{2}$ "	2 $\frac{1}{4}$ "	$\frac{7}{8}$ "	1 $\frac{1}{8}$ "	1 $\frac{3}{4}$ "	4"	6"	10"
AWST 30-36	36"	24"	21"	19 $\frac{1}{8}$ "	16"	4 $\frac{1}{8}$ "	1 $\frac{1}{2}$ "	1 $\frac{3}{4}$ "	2"	1 $\frac{1}{4}$ "	2 $\frac{3}{8}$ "	4"	8"	12"

MODEL	MOTOR SPEED	CFM DELIVERED AGAINST EXTERNAL STATIC PRESSURE				
		0.1"	0.2"	0.3"	0.4"	0.5"
AWST18SU14** BA	T1	630	602	576	550	521
	T2	630	602	576	550	521
	T3	637	609	586	557	531
	T4	630	602	576	550	521
	T5	846	824	800	777	756
AWST24SU14** BA	T1	630	602	576	550	521
	T2	630	602	576	550	521
	T3	784	763	742	728	705
	T4	630	602	576	550	521
	T5	846	823	800	777	756
AWST30LU14** BA	T1	683	604	525	460	369
	T2	900	856	803	734	681
	T3	1079	1025	989	949	889
	T4	944	897	848	783	733
	T5	1168	1127	1083	1050	1005
AWST36LU14** BA	T1	1114	1072	1031	982	924
	T2	1114	1072	1031	982	924
	T3	1225	1191	1152	1112	1071
	T4	1287	1255	1219	1183	1146
	T5	1360	1329	1299	1264	1230





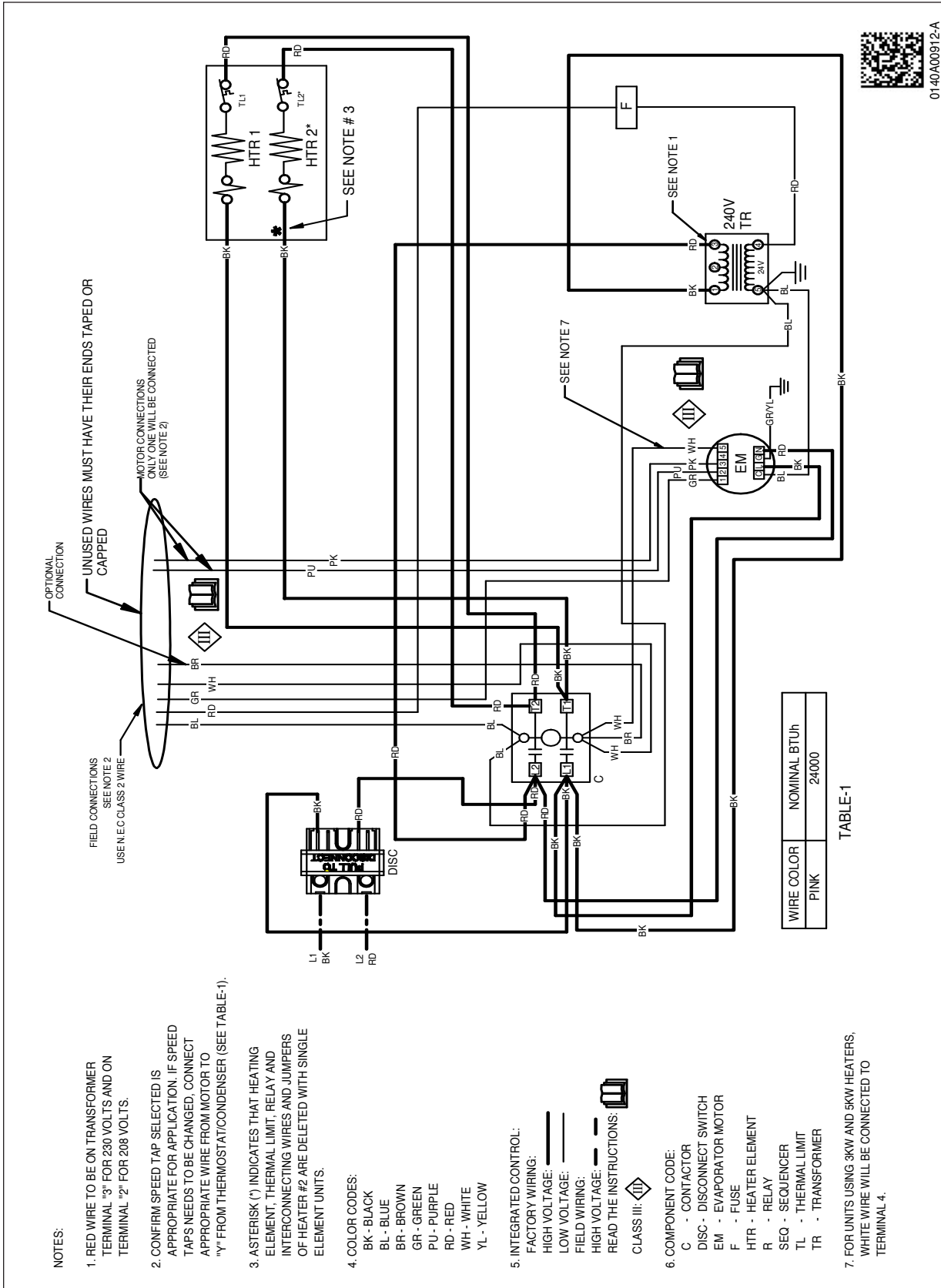

**WARNING**

**High Voltage:** Disconnect all power before servicing or installing this unit. Multiple power sources may be present. Failure to do so may cause property damage, personal injury, or death.

Wiring is subject to change. Always refer to the wiring diagram on the unit for the most up-to-date wiring.

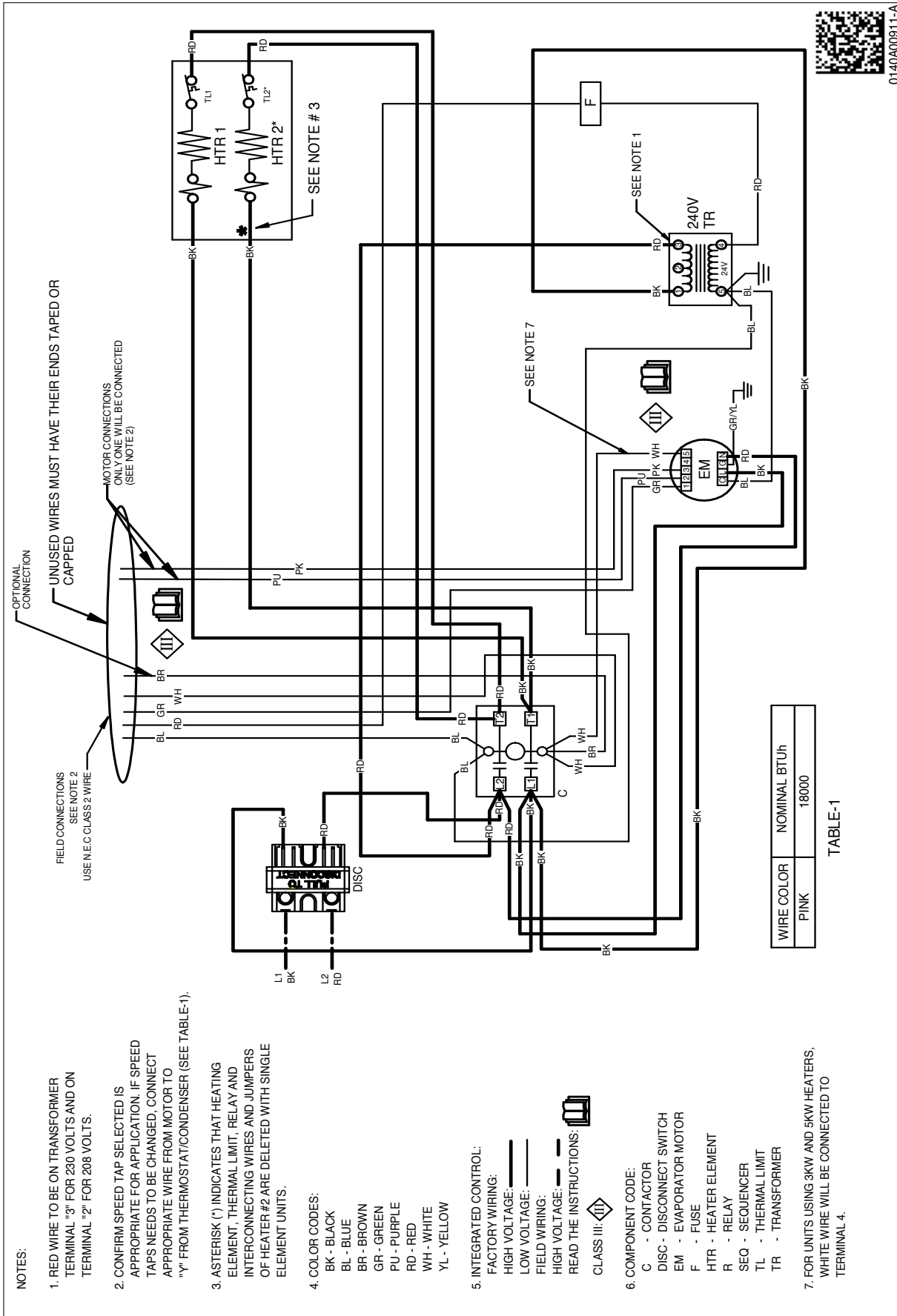

Wiring is subject to change. Always refer to the wiring diagram on the unit for the most up-to-date wiring.

**WARNING**

**High Voltage:** Disconnect all power before servicing or installing this unit. Multiple power sources may be present. Failure to do so may cause property damage, personal injury, or death.



