



# DC3SEA COMMERCIAL

**COOLING CAPACITY:**  
36,000 - 60,000 BTU/H

**3, 4, & 5-TON, THREE-PHASE  
SPLIT SYSTEM AIR CONDITIONER**



### ■ Contents

Nomenclature.....	2
Product Specifications.....	3
Expanded Cooling Data.....	4
Performance.....	10
AHRI Ratings.....	11
Dimensions.....	12
Wiring Diagram.....	13
Accessories.....	14

**R32**

### ■ Standard Features

- High efficiency scroll compressor
- Advanced Copeland® CoreSense™ Technology
- Fully charged for 15' of tubing length
- Copper tube/ enhanced aluminum fin coil 5mm diameter
- Factory-installed filter drier
- Sweat connection service valves with easy access to gauge ports
- Enclosed contactor
- High-pressure switch
- Ground lug connection
- Capacitors with extended life
- AHRI Certified
- ETL Listed

### ■ Cabinet Features

- Removable grille-style top design compliant with UL 60335-2-40
- Venturi for increased velocity of airflow
- Custom Nickel Gray powder- paint finish with 500- hour salt- spray approval
- Steel louver coil guard with rust-resistant screws
- Wire fan discharge grille
- Steel louver coil guard
- Rust-resistant screws
- Top and side maintenance access
- Single-panel access to controls with space provided for field-installed accessories



\* Complete warranty details available from your local distributor or manufacturer's representative or at [www.daikincomfort.com](http://www.daikincomfort.com).

	D	C	3	S	E	A	36	3	0	A	A	
	1	2	3	4	5	6	7,8	9	10	11	*	
<b>Brand</b> D - Daikin												<b>Minor revision</b> A: Intial Release B: 1st Revision
<b>Type - Split System</b> C - Condenser R32 H - Heat Pump R32												<b>Major revision</b> A: Intial Release B: 1st Revision
<b>Efficiency (SEER2)</b> 13.4 SEER2 = 3 14.3 SEER2 = 4												<b>Variations</b>
<b>Compressor Type</b> S - Single Stage												<b>Electrical</b> 3 - 1 208/230 V, 3 Phase, 60 Hz 4 - 460 V, 3 Phase, 60 Hz
<b>Feature</b> E - Base												<b>Nominal Capacity</b> 36 - 3 Tons 48 - 4 Tons 60 - 5 Tons
<b>Sales Region</b> A - All Region												

	DC3SEA 3630A*	DC3SEA 4830A*	DC3SEA 6030A*	DC3SEA 3640A*	DC3SEA 4840A*	DC3SEA 6040A*
<b>COOLING CAPACITIES</b>						
Nominal Cooling (BTU/h)	36,000	48,000	60,000	36,000	48,000	60,000
Decibels	71.0	72.0	72.0	71.0	72.0	72.0
<b>COMPRESSOR</b>						
RLA	10.8	12.2	15.4	4.9	5.8	7.7
LRA	97.5	120.0	156.0	44.3	55.1	69.0
Stage	Single	Single	Single	Single	Single	Single
Type	Scroll	Scroll	Scroll	Scroll	Scroll	Scroll
<b>CONDENSER FAN MOTOR</b>						
Motor Type	PSC	PSC	PSC	PSC	PSC	PSC
Horsepower (RPM)	1/8	1/4	1/4	1/6	1/4	1/4
FLA	0.70	1.40	1.30	0.60	0.70	0.80
<b>REFRIGERATION SYSTEM</b>						
Refrigerant Line Size <sup>1</sup>						
Liquid Line Size ("O.D.)	3/8"	3/8"	3/8"	3/8"	3/8"	3/8"
Suction Line Size ("O.D.)	7/8"	1 1/8"	1 1/8"	7/8"	1 1/8"	1 1/8"
Refrigerant Connection Type						
Liquid Valve Size ("O.D.)	3/8"	3/8"	3/8"	3/8"	3/8"	3/8"
Suction Valve Size ("O.D.) <sup>2</sup>	3/4"	7/8"	7/8"	3/4"	7/8"	7/8"
Valve Connection Type	Sweat	Sweat	Sweat	Sweat	Sweat	Sweat
Refrigerant Charge <sup>3</sup>	60	84	91	60	84	91
<b>ELECTRICAL DATA</b>						
Voltage-Phase	208/230-3	208/230-3	208/230-3	460	460	460
Minimum Circuit Ampacity <sup>4</sup>	14.2	16.6	20.5	6.7	7.9	10.4
Max. Overcurrent Protection <sup>5</sup>	25.0	25.0	35.0	10.0	10.0	15.0
Min / Max Volts	197/253	197/253	197/253	437/506	437/506	437/506
Electrical Conduit Size	1/2" or 3/4"	1/2" or 3/4"	1/2" or 3/4"	1/2" or 3/4"	1/2" or 3/4"	1/2" or 3/4"
<b>EQUIPMENT WEIGHT (LBS)</b>						
	133	183	222	134	188	224
<b>SHIP WEIGHT (LBS)</b>						
	148	198	237	149	203	239

<sup>1</sup> Line sizes denoted for 25' line sets, tested and rated in accordance with ARI Standard 210/240. For other line set lengths or sizes, refer to the Installation Instructions and/or the Long Line Set Applications guide.

<sup>2</sup> Any suction line adapter will need to be supplied by the field.

<sup>3</sup> Unit is factory charged with refrigerant for 15' of 3/8" liquid line. System charge must be adjusted per the Final Charge Adjustment procedure found in the Installation Instructions.

<sup>4</sup> Wire size should be determined in accordance with National Electrical Codes; extensive wire runs will require larger wire sizes

<sup>5</sup> Must use time-delay fuses or HACR-type circuit breakers of the same size as noted.

**NOTES**

- Always check the S&R plate for electrical data on the unit being installed.

IDB		OUTDOOR AMBIENT TEMPERATURE																											
		65				75				85				95				105				115							
		59	63	67	71	59	63	67	71	59	63	67	71	59	63	67	71	59	63	67	71	59	63	67	71				
		ENTERING INDOOR WET BULB TEMPERATURE																											
AIRFLOW		59	63	67	71	59	63	67	71	59	63	67	71	59	63	67	71	59	63	67	71	59	63	67	71	59	63	67	71
70	MBh	34.9	35.4	36.5	-	34.6	35.1	36.1	-	33.7	34.2	35.2	-	32.1	32.6	33.7	-	30.2	30.7	31.8	-	28.5	29.0	30.0	-				
	S/T	0.63	0.55	0.42	-	0.64	0.56	0.42	-	0.66	0.58	0.45	-	1.00	0.60	0.47	-	1.00	0.63	0.49	-	1.00	0.68	0.54	-				
	ΔT	20	18	15	-	20	18	15	-	20	18	15	-	20	18	15	-	20	18	14	-	21	19	15	-				
	kW	2.19	2.19	2.19	-	2.46	2.46	2.45	-	2.75	2.75	2.75	-	3.08	3.07	3.07	-	3.43	3.43	3.43	-	3.85	3.85	3.85	-				
	Amps	8.0	8.0	8.0	-	9.2	9.2	9.2	-	10.6	10.6	10.6	-	12.1	12.0	12.0	-	13.7	13.7	13.7	-	15.6	15.6	15.6	-				
70	MBh	35.3	35.7	36.8	-	34.9	35.4	36.5	-	34.0	34.5	35.6	-	32.5	33.0	34.0	-	30.6	31.0	32.1	-	28.8	29.3	30.3	-				
	S/T	0.67	0.59	0.46	-	0.67	0.60	0.46	-	1.00	0.62	0.49	-	1.00	0.64	0.51	-	1.00	0.66	0.53	-	1.00	0.72	0.58	-				
	ΔT	19	17	14	-	19	17	14	-	19	18	14	-	19	17	14	-	19	17	14	-	20	18	15	-				
	kW	2.20	2.20	2.20	-	2.47	2.47	2.46	-	2.76	2.76	2.76	-	3.08	3.08	3.08	-	3.44	3.44	3.44	-	3.86	3.86	3.86	-				
	Amps	8.1	8.1	8.0	-	9.3	9.3	9.2	-	10.6	10.6	10.6	-	12.1	12.1	12.1	-	13.7	13.7	13.7	-	15.7	15.6	15.6	-				
70	MBh	36.0	36.5	37.6	-	35.7	36.2	37.3	-	34.8	35.3	36.4	-	33.3	33.8	34.8	-	31.4	31.8	32.9	-	29.6	30.1	31.1	-				
	S/T	0.71	0.63	0.50	-	0.72	0.64	0.50	-	1.00	0.66	0.53	-	1.00	0.68	0.55	-	1.00	0.71	0.57	-	1.00	1.00	0.62	-				
	ΔT	18	16	13	-	18	16	12	-	18	16	13	-	18	16	12	-	18	16	12	-	19	17	13	-				
	kW	2.22	2.22	2.21	-	2.48	2.48	2.48	-	2.78	2.78	2.77	-	3.10	3.10	3.09	-	3.46	3.46	3.45	-	3.88	3.88	3.87	-				
	Amps	8.1	8.1	8.1	-	9.4	9.3	9.3	-	10.7	10.7	10.7	-	12.2	12.2	12.1	-	13.8	13.8	13.8	-	15.7	15.7	15.7	-				
75	MBh	34.9	35.4	36.5	38.1	34.6	35.1	36.2	37.8	33.7	34.2	35.3	36.8	32.2	32.7	33.7	35.3	30.3	30.7	31.8	33.4	28.5	29.0	30.0	31.6				
	S/T	0.76	0.68	0.55	0.4	1.00	0.69	0.55	0.4	1.00	0.71	0.58	0.4	1.00	0.73	0.60	0.5	1.00	1.00	0.62	0.5	1.00	1.00	0.67	0.5				
	ΔT	24	22	19	15	24	22	19	15	24	23	19	15	24	22	19	15	24	22	18	15	25	23	20	16				
	kW	2.19	2.19	2.19	2.2	2.46	2.46	2.45	2.5	2.75	2.75	2.75	2.8	3.07	3.07	3.07	3.1	3.43	3.43	3.42	3.4	3.85	3.85	3.84	3.9				
	Amps	8.0	8.0	8.0	8.1	9.2	9.2	9.2	9.3	10.6	10.6	10.6	10.6	12.0	12.0	12.0	12.1	13.7	13.7	13.7	13.7	15.6	15.6	15.6	15.7				
75	MBh	35.3	35.8	36.8	38.4	35.0	35.5	36.5	38.1	34.1	34.5	35.6	37.2	32.5	33.0	34.0	35.6	30.6	31.1	32.1	33.7	28.8	29.3	30.4	32.0				
	S/T	0.80	0.72	0.58	0.4	1.00	0.73	0.59	0.4	1.00	0.75	0.62	0.5	1.00	0.77	0.64	0.5	1.00	1.00	0.66	0.5	1.00	1.00	0.71	0.6				
	ΔT	23	22	18	14	23	21	18	14	24	22	18	15	23	21	18	14	23	21	18	14	24	22	19	15				
	kW	2.20	2.20	2.20	2.22	2.47	2.46	2.46	2.48	2.76	2.76	2.76	2.78	3.08	3.08	3.08	3.10	3.44	3.44	3.43	3.45	3.86	3.86	3.85	3.87				
	Amps	8.1	8.0	8.0	8.1	9.3	9.3	9.2	9.3	10.6	10.6	10.6	10.7	12.1	12.1	12.1	12.2	13.7	13.7	13.7	13.8	15.6	15.6	15.6	15.7				
75	MBh	36.1	36.6	37.6	39.2	35.8	36.2	37.3	38.9	34.8	35.3	36.4	38.0	33.3	33.8	34.8	36.4	31.4	31.9	32.9	34.5	29.6	30.1	31.2	32.7				
	S/T	0.84	0.76	0.63	0.5	1.00	0.77	0.63	0.5	1.00	0.79	0.66	0.5	1.00	0.81	0.68	0.5	1.00	1.00	0.70	0.6	1.00	1.00	0.75	0.6				
	ΔT	22	20	17	13	22	20	17	13	22	20	17	13	22	20	17	13	22	20	16	13	23	21	18	14				
	kW	2.22	2.22	2.21	2.2	2.48	2.48	2.48	2.5	2.78	2.78	2.77	2.8	3.10	3.10	3.09	3.1	3.46	3.45	3.45	3.5	3.88	3.87	3.87	3.9				
	Amps	8.1	8.1	8.1	8.2	9.3	9.3	9.3	9.4	10.7	10.7	10.7	10.8	12.2	12.2	12.1	12.2	13.8	13.8	13.8	13.9	15.7	15.7	15.7	15.8				

IDB: Entering Indoor Dry Bulb Temperature  
 High and low pressures are measured at the liquid and suction service valves.  
 Shaded area is ACCA (TVA) conditions.  
 kW=Total system power  
 Amps = outdoor unit amps (comp.+fan)

IDB		OUTDOOR AMBIENT TEMPERATURE																											
		65				75				85				95				105				115							
		59	63	67	71	59	63	67	71	59	63	67	71	59	63	67	71	59	63	67	71	59	63	67	71				
		ENTERING INDOOR WET BULB TEMPERATURE																											
AIRFLOW		59	63	67	71	59	63	67	71	59	63	67	71	59	63	67	71	59	63	67	71	59	63	67	71	59	63	67	71
1050	MBh	35.1	35.6	36.7	38.2	34.8	35.3	36.3	37.9	33.9	34.4	35.4	37.0	32.3	32.8	33.9	35.5	30.4	30.9	32.0	33.6	28.7	29.2	30.2	31.8				
	S/T	1.00	0.81	0.67	0.5	1.00	0.81	0.68	0.5	1.00	0.84	0.70	0.6	1.00	1.00	0.72	0.6	1.00	1.00	0.74	0.6	1.00	1.00	0.80	0.7				
	ΔT	28	26	23	19	28	26	23	19	29	27	23	20	28	26	23	19	28	26	23	19	29	27	24	20				
	kW	2.19	2.19	2.19	2.2	2.46	2.46	2.45	2.5	2.75	2.75	2.75	2.8	3.07	3.07	3.07	3.1	3.43	3.43	3.43	3.4	3.85	3.85	3.85	3.9				
	Amps	8.0	8.0	8.0	8.1	9.2	9.2	9.2	9.3	10.6	10.6	10.6	10.7	12.1	12.0	12.0	12.1	13.7	13.7	13.7	13.8	15.6	15.6	15.6	15.7				
80	MBh	35.5	35.9	37.0	38.6	35.1	35.6	36.7	38.3	34.2	34.7	35.8	37.4	32.7	33.2	34.2	35.8	30.8	31.2	32.3	33.9	29.0	29.5	30.5	32.1				
	S/T	1.00	0.85	0.71	0.6	1.00	0.85	0.72	0.6	1.00	1.00	0.74	0.6	1.00	1.00	0.76	0.6	1.00	1.00	0.78	0.6	1.00	1.00	1.00	0.7				
	ΔT	28	26	22	19	28	26	22	19	28	26	22	19	28	26	22	18	27	25	22	18	28	27	23	19				
	kW	2.20	2.20	2.20	2.22	2.47	2.47	2.46	2.48	2.76	2.76	2.76	2.78	3.08	3.08	3.08	3.10	3.44	3.44	3.44	3.46	3.86	3.86	3.85	3.88				
	Amps	8.1	8.1	8.0	8.1	9.3	9.3	9.2	9.3	10.6	10.6	10.6	10.7	12.1	12.1	12.1	12.2	13.7	13.7	13.7	13.8	15.7	15.6	15.6	15.7				
1350	MBh	36.2	36.7	37.8	39.4	35.9	36.4	37.5	39.1	35.0	35.5	36.6	38.1	33.5	34.0	35.0	36.6	31.6	32.0	33.1	34.7	29.8	30.3	31.3	32.9				
	S/T	1.00	0.89	0.75	0.6	1.00	0.89	0.76	0.6	1.00	1.00	0.78	0.6	1.00	1.00	0.80	0.7	1.00	1.00	0.82	0.7	1.00	1.00	1.00	0.7				
	ΔT	26	24	21	17	26	24	21	17	27	25	21	17	26	24	21	17	26	24	21	17	27	25	22	18				
	kW	2.22	2.22	2.21	2.2	2.48	2.48	2.48	2.5	2.78	2.78	2.77	2.8	3.10	3.10	3.09	3.1	3.46	3.46	3.45	3.5	3.88	3.88	3.87	3.9				
	Amps	8.1	8.1	8.1	8.2	9.3	9.3	9.3	9.4	10.7	10.7	10.7	10.8	12.2	12.2	12.1	12.2	13.8	13.8	13.8	13.9	15.7	15.7	15.7	15.8				
85	MBh	35.7	36.2	37.2	38.8	35.4	35.9	36.9	38.5	34.5	35.0	36.0	37.6	32.9	33.4	34.5	36.0	31.0	31.5	32.5	34.1	29.3	29.8	30.8	32.4				
	S/T	1.00	0.91	0.77	0.6	1.00	1.00	0.78	0.6	1.00	1.00	0.80	0.7	1.00	1.00	0.82	0.7	1.00	1.00	1.00	0.7	1.00	1.00	1.00	0.8				
	ΔT	32	30	27	23	32	30	27	23	32	30	27	23	32	30	27	23	32	30	26	23	33	31	28	24				
	kW	2.20	2.20	2.19	2.2	2.46	2.46	2.46	2.5	2.76	2.76	2.75	2.8	3.08	3.08	3.07	3.1	3.44	3.44	3.43	3.5	3.86	3.86	3.85	3.9				
	Amps	8.0	8.0	8.0	8.1	9.3	9.2	9.2	9.3	10.6	10.6	10.6	10.7	12.1	12.1	12.0	12.1	13.7	13.7	13.7	13.8	15.6	15.6	15.6	15.7				
1150	MBh	36.0	36.5	37.6	39.2	35.7	36.2	37.3	38.8	34.8	35.3	36.3	37.9	33.3	33.7	34.8	36.4	31.3	31.8	32.9	34.5	29.6	30.1	31.1	32.7				
	S/T	1.00	0.95	0.81	0.7	1.00	1.00	0.82	0.7	1.00	1.00	0.84	0.7	1.00	1.00	0.86	0.7	1.00	1.00	1.00	0.7	1.00	1.00	1.00	0.8				
	ΔT	31	29	26	22	31	29	26	22	32	30	26	22	31	29	26	22	31	29	26	22	32	30	27	23				
	kW	2.21	2.21	2.20	2.22	2.47	2.47	2.47	2.49	2.77	2.77	2.76	2.78	3.09	3.09	3.08	3.10	3.45	3.44	3.44	3.46	3.87	3.86	3.86	3.88				
	Amps	8.1	8.1	8.1	8.1	9.3	9.3	9.3	9.4	10.7	10.6	10.6	10.7	12.1	12.1	12.1	12.2	13.8	13.7	13.7	13.8	15.7	15.7	15.6	15.7				
1350	MBh	36.8	37.3	38.4	39.9	36.5	37.0	38.1	39.6	35.6	36.1	37.1	38.7	34.0	34.5	35.6	37.2	32.1	32.6	33.7	35.3	30.4	30.9	31.9	33.5				
	S/T	1.00	1.00	0.85	0.7	1.00	1.00	0.86	0.7	1.00	1.00	0.88	0.7	1.00	1.00	1.00	0.8	1.00	1.00	1.00	0.8	1.00	1.00	1.00	0.8				
	ΔT	30	28	25	21	30	28	25	21	30	28	25	21	30	28	25	21	30	28	24	21	31	29	25	22				
	kW	2.22	2.22	2.22	2.2	2.49	2.49	2.48	2.5	2.78	2.78	2.78	2.8	3.10	3.10	3.10	3.1	3.46	3.46	3.46	3.5	3.88	3.88	3.88	3.9				
	Amps	8.2	8.1	8.1	8.2	9.4	9.4	9.3	9.4	10.7	10.7	10.7	10.8	12.2	12.2	12.2	12.3	13.8	13.8	13.8	13.9	15.7	15.7	15.7	15.8				

IDB: Entering Indoor Dry Bulb Temperature  
 High and low pressures are measured at the liquid and suction service valves.  
 Shaded area is ACCA (TVA) conditions.  
 kW= Total system power  
 Amps = outdoor unit amps (comp.+fan)

EXPANDED COOLING DATA — DC3SEA4830A\*/4840A\*+ CAPTA6030A\*

IDB		OUTDOOR AMBIENT TEMPERATURE																																			
		65						75						85						95						105						115					
		59	63	67	71	59	63	67	71	59	63	67	71	59	63	67	71	59	63	67	71	59	63	67	71	59	63	67	71								
		ENTERING INDOOR WET BULB TEMPERATURE																																			
AIRFLOW		59	63	67	71	59	63	67	71	59	63	67	71	59	63	67	71	59	63	67	71	59	63	67	71	59	63	67	71								
1400	MBh	46.9	47.6	48.9	-	46.5	47.1	48.5	-	45.3	45.9	47.3	-	43.2	43.9	45.2	-	40.7	41.3	42.7	-	38.3	39.0	40.4	-	38.3	39.0	40.4	-								
	S/T	0.64	0.56	0.43	-	0.64	0.57	0.44	-	0.67	0.59	0.46	-	1.00	0.61	0.48	-	1.00	0.63	0.50	-	1.00	0.68	0.55	-	1.00	0.68	0.55	-								
	ΔT	20	18	15	-	20	18	14	-	20	18	15	-	20	18	14	-	20	18	14	-	21	19	15	-	21	19	15	-								
	kW	3.03	3.03	3.02	-	3.37	3.37	3.37	-	3.76	3.76	3.75	-	4.18	4.17	4.17	-	4.64	4.64	4.63	-	5.19	5.19	5.18	-	5.19	5.19	5.18	-								
	Amps	11.0	11.0	11.0	-	12.6	12.6	12.6	-	14.4	14.4	14.3	-	16.3	16.3	16.3	-	18.4	18.4	18.4	-	20.9	20.9	20.9	-	20.9	20.9	20.9	-								
70	MBh	47.7	48.4	49.8	-	47.3	48.0	49.4	-	46.1	46.8	48.2	-	44.0	44.7	46.1	-	41.5	42.2	43.5	-	39.2	39.8	41.2	-	39.2	39.8	41.2	-								
	S/T	0.67	0.60	0.47	-	0.68	0.60	0.48	-	0.70	0.63	0.50	-	1.00	0.65	0.52	-	1.00	0.67	0.54	-	1.00	0.72	0.59	-	1.00	0.72	0.59	-								
	ΔT	19	17	13	-	19	17	13	-	19	17	14	-	19	17	13	-	19	17	13	-	20	18	14	-	20	18	14	-								
	kW	3.05	3.04	3.04	-	3.39	3.39	3.38	-	3.78	3.77	3.77	-	4.19	4.19	4.18	-	4.66	4.66	4.65	-	5.21	5.20	5.20	-	5.21	5.20	5.20	-								
	Amps	11.1	11.1	11.1	-	12.7	12.7	12.7	-	14.5	14.4	14.4	-	16.4	16.4	16.3	-	18.5	18.5	18.5	-	21.0	21.0	21.0	-	21.0	21.0	21.0	-								
1800	MBh	48.8	49.4	50.8	-	48.4	49.0	50.4	-	47.2	47.8	49.2	-	45.1	45.7	47.1	-	42.5	43.2	44.6	-	40.2	40.9	42.3	-	40.2	40.9	42.3	-								
	S/T	0.68	0.61	0.48	-	0.68	0.61	0.48	-	1.00	0.64	0.51	-	1.00	0.65	0.53	-	1.00	0.68	0.55	-	1.00	0.72	0.60	-	1.00	0.72	0.60	-								
	ΔT	18	16	12	-	18	16	12	-	18	16	13	-	18	16	12	-	18	16	12	-	19	17	13	-	19	17	13	-								
	kW	3.06	3.06	3.05	-	3.41	3.40	3.40	-	3.79	3.79	3.78	-	4.21	4.21	4.20	-	4.67	4.67	4.67	-	5.22	5.22	5.21	-	5.22	5.22	5.21	-								
	Amps	11.2	11.2	11.1	-	12.8	12.8	12.7	-	14.5	14.5	14.5	-	16.4	16.4	16.4	-	18.6	18.6	18.5	-	21.1	21.1	21.0	-	21.1	21.1	21.0	-								
1400	MBh	46.9	47.6	49.0	51.1	46.5	47.2	48.5	50.7	45.3	46.0	47.3	49.5	43.2	43.9	45.3	47.4	40.7	41.3	42.7	44.8	38.4	39.0	40.4	42.5	38.4	39.0	40.4	42.5								
	S/T	0.76	0.69	0.56	0.4	0.77	0.69	0.56	0.4	1.00	0.72	0.59	0.5	1.00	0.74	0.61	0.5	1.00	0.76	0.63	0.5	1.00	1.00	0.68	0.5	1.00	1.00	0.68	0.5								
	ΔT	25	23	19	15	24	23	19	15	25	23	19	15	24	22	19	15	24	22	19	15	25	23	20	16	25	23	20	16								
	kW	3.03	3.02	3.02	3.0	3.37	3.37	3.36	3.4	3.76	3.75	3.75	3.8	4.17	4.17	4.17	4.2	4.64	4.64	4.63	4.7	5.19	5.18	5.18	5.2	5.19	5.18	5.18	5.2								
	Amps	11.0	11.0	11.0	11.1	12.6	12.6	12.6	12.7	14.4	14.4	14.3	14.5	16.3	16.3	16.2	16.4	18.4	18.4	18.4	18.5	20.9	20.9	20.9	21.0	20.9	20.9	20.9	21.0								
75	MBh	47.8	48.4	49.8	51.9	47.4	48.0	49.4	51.5	46.1	46.8	48.2	50.3	44.1	44.7	46.1	48.2	41.5	42.2	43.6	45.7	39.2	39.9	41.2	43.4	39.2	39.9	41.2	43.4								
	S/T	0.79	0.72	0.59	0.5	1.00	0.73	0.60	0.5	1.00	0.75	0.62	0.5	1.00	0.77	0.64	0.5	1.00	0.79	0.66	0.5	1.00	1.00	0.71	0.6	1.00	1.00	0.71	0.6								
	ΔT	23	21	18	14	23	21	18	14	24	22	18	14	23	21	18	14	23	21	17	14	24	22	19	15	24	22	19	15								
	kW	3.04	3.04	3.03	3.06	3.39	3.39	3.38	3.41	3.77	3.77	3.77	3.79	4.19	4.19	4.18	4.21	4.66	4.65	4.65	4.68	5.20	5.20	5.20	5.22	5.20	5.20	5.20	5.22								
	Amps	11.1	11.1	11.1	11.2	12.7	12.7	12.6	12.8	14.4	14.4	14.4	14.5	16.4	16.3	16.3	16.4	18.5	18.5	18.5	18.6	21.0	21.0	21.0	21.1	21.0	21.0	21.0	21.1								
1800	MBh	48.8	49.5	50.9	53.0	48.4	49.1	50.4	52.5	47.2	47.8	49.2	51.3	45.1	45.8	47.1	49.3	42.6	43.2	44.6	46.7	40.2	40.9	42.3	44.4	40.2	40.9	42.3	44.4								
	S/T	0.80	0.73	0.60	0.5	1.00	0.74	0.61	0.5	1.00	0.76	0.63	0.5	1.00	0.78	0.65	0.5	1.00	1.00	0.67	0.5	1.00	1.00	0.72	0.6	1.00	1.00	0.72	0.6								
	ΔT	22	20	17	13	22	20	17	13	23	21	17	13	22	20	17	13	22	20	16	13	23	21	18	14	23	21	18	14								
	kW	3.06	3.06	3.05	3.1	3.40	3.40	3.39	3.4	3.79	3.79	3.78	3.8	4.21	4.20	4.20	4.2	4.67	4.67	4.66	4.7	5.22	5.22	5.21	5.2	5.22	5.22	5.21	5.2								
	Amps	11.2	11.2	11.1	11.3	12.8	12.7	12.7	12.8	14.5	14.5	14.5	14.6	16.4	16.4	16.4	16.5	18.6	18.5	18.5	18.6	21.1	21.0	21.0	21.1	21.1	21.0	21.0	21.1								

IDB: Entering Indoor Dry Bulb Temperature  
 High and low pressures are measured at the liquid and suction service valves.  
 Shaded area is ACCA (TVA) conditions.  
 KW=Total system power  
 Amps = outdoor unit amps (comp.+fan)

IDB		OUTDOOR AMBIENT TEMPERATURE																							
		65				75				85				95				105				115			
		ENTERING INDOOR WET BULB TEMPERATURE																							
AIRFLOW	59	63	67	71	59	63	67	71	59	63	67	71	59	63	67	71	59	63	67	71	59	63	67	71	
<b>1400</b>	MBh	47.2	47.8	49.2	51.3	46.8	47.4	48.8	50.9	45.5	46.2	47.6	49.7	43.5	44.1	45.5	47.6	40.9	41.6	43.0	45.1	38.6	39.3	40.6	42.8
	S/T	1.00	0.81	0.68	0.5	1.00	0.81	0.68	0.5	1.00	0.84	0.71	0.6	1.00	1.00	0.73	0.6	1.00	1.00	0.75	0.6	1.00	1.00	0.80	0.7
	ΔT	29	27	23	19	29	27	23	19	29	27	23	20	29	27	23	19	29	27	23	19	30	28	24	20
	kW	3.03	3.03	3.02	3.0	3.37	3.37	3.36	3.4	3.76	3.76	3.75	3.8	4.18	4.17	4.17	4.2	4.64	4.64	4.63	4.7	5.19	5.19	5.18	5.2
	Amps	11.0	11.0	11.0	11.1	12.6	12.6	12.6	12.7	14.4	14.4	14.3	14.5	16.3	16.3	16.2	16.4	18.4	18.4	18.4	18.5	20.9	20.9	20.9	21.0
<b>1600</b>	MBh	48.0	48.7	50.0	52.2	47.6	48.3	49.6	51.7	46.4	47.0	48.4	50.5	44.3	45.0	<b>46.3</b>	48.5	41.8	42.4	43.8	45.9	39.4	40.1	41.5	43.6
	S/T	1.00	0.84	0.71	0.6	1.00	0.85	0.72	0.6	1.00	0.87	0.74	0.6	1.00	1.00	<b>0.76</b>	0.6	1.00	1.00	0.78	0.6	1.00	1.00	0.83	0.7
	ΔT	28	26	22	18	28	26	22	18	28	26	22	19	28	26	<b>22</b>	18	27	25	22	18	29	27	23	19
	kW	3.05	3.04	3.04	3.06	3.39	3.39	3.38	3.41	3.78	3.77	3.77	3.79	4.19	4.19	<b>4.18</b>	4.21	4.66	4.66	4.65	4.68	5.21	5.20	5.20	5.22
	Amps	11.1	11.1	11.1	11.2	12.7	12.7	12.7	12.8	14.5	14.4	14.4	14.5	16.4	16.4	<b>16.3</b>	16.4	18.5	18.5	18.5	18.6	21.0	21.0	21.0	21.1
<b>1800</b>	MBh	49.1	49.7	51.1	53.2	48.6	49.3	50.7	52.8	47.4	48.1	49.5	51.6	45.4	46.0	47.4	49.5	42.8	43.5	44.8	47.0	40.5	41.1	42.5	44.6
	S/T	1.00	0.85	0.72	0.6	1.00	0.86	0.73	0.6	1.00	1.00	0.75	0.6	1.00	1.00	0.77	0.6	1.00	1.00	0.79	0.7	1.00	1.00	0.84	0.7
	ΔT	27	25	21	17	27	25	21	17	27	25	21	18	27	25	21	17	26	24	21	17	28	26	22	18
	kW	3.06	3.06	3.05	3.1	3.41	3.40	3.40	3.4	3.79	3.79	3.78	3.8	4.21	4.21	4.20	4.2	4.67	4.67	4.67	4.7	5.22	5.22	5.21	5.2
	Amps	11.2	11.2	11.1	11.3	12.8	12.7	12.7	12.8	14.5	14.5	14.5	14.6	16.4	16.4	16.4	16.5	18.6	18.6	18.5	18.6	21.1	21.1	21.0	21.2
<b>1400</b>	MBh	47.9	48.6	50.0	52.1	47.5	48.2	49.6	51.7	46.3	47.0	48.4	50.5	44.2	44.9	46.3	48.4	41.7	42.4	43.7	45.9	39.4	40.0	41.4	43.5
	S/T	1.00	0.90	0.77	0.6	1.00	1.00	0.78	0.6	1.00	1.00	0.80	0.7	1.00	1.00	0.82	0.7	1.00	1.00	0.84	0.7	1.00	1.00	1.00	0.8
	ΔT	33	31	27	23	33	31	27	23	33	31	27	24	33	31	27	23	32	30	27	23	34	32	28	24
	kW	3.03	3.03	3.03	3.1	3.38	3.38	3.37	3.4	3.77	3.76	3.76	3.8	4.18	4.18	4.17	4.2	4.65	4.65	4.64	4.7	5.20	5.19	5.19	5.2
	Amps	11.1	11.1	11.0	11.1	12.6	12.6	12.6	12.7	14.4	14.4	14.4	14.5	16.3	16.3	16.3	16.4	18.5	18.4	18.4	18.5	21.0	20.9	20.9	21.0
<b>1600</b>	MBh	48.8	49.4	50.8	52.9	48.4	49.0	50.4	52.5	47.2	47.8	49.2	51.3	45.1	45.7	47.1	49.2	42.5	43.2	44.6	46.7	40.2	40.9	42.3	44.4
	S/T	1.00	0.94	0.81	0.7	1.00	1.00	0.82	0.7	1.00	1.00	0.84	0.7	1.00	1.00	0.86	0.7	1.00	1.00	1.00	0.7	1.00	1.00	1.00	0.8
	ΔT	32	30	26	22	32	30	26	22	32	30	26	22	32	30	26	22	31	29	26	22	33	31	27	23
	kW	3.05	3.05	3.04	3.07	3.40	3.39	3.39	3.41	3.78	3.78	3.77	3.80	4.20	4.20	4.19	4.22	4.67	4.66	4.66	4.68	5.21	5.21	5.20	5.23
	Amps	11.1	11.1	11.1	11.2	12.7	12.7	12.7	12.8	14.5	14.5	14.4	14.6	16.4	16.4	16.4	16.5	18.5	18.5	18.5	18.6	21.0	21.0	21.0	21.1
<b>1800</b>	MBh	49.8	50.5	51.9	54.0	49.4	50.1	51.5	53.6	48.2	48.9	50.2	52.4	46.1	46.8	48.2	50.3	43.6	44.2	45.6	47.7	41.3	41.9	43.3	45.4
	S/T	1.00	0.95	0.82	0.7	1.00	1.00	0.82	0.7	1.00	1.00	0.85	0.7	1.00	1.00	0.87	0.7	1.00	1.00	1.00	0.7	1.00	1.00	1.00	0.8
	ΔT	31	29	25	21	31	29	25	21	31	29	25	21	31	29	25	21	30	28	25	21	32	30	26	22
	kW	3.07	3.06	3.06	3.1	3.41	3.41	3.40	3.4	3.80	3.79	3.79	3.8	4.21	4.21	4.21	4.2	4.68	4.68	4.67	4.7	5.23	5.22	5.22	5.2
	Amps	11.2	11.2	11.2	11.3	12.8	12.8	12.8	12.9	14.6	14.5	14.5	14.6	16.5	16.5	16.4	16.5	18.6	18.6	18.6	18.7	21.1	21.1	21.1	21.2

IDB: Entering Indoor Dry Bulb Temperature  
 High and low pressures are measured at the liquid and suction service valves.  
 Shaded area is ACCA (TVA) conditions.  
 kW= Total system power  
 Amps = outdoor unit amps (comp.+fan)

IDB		OUTDOOR AMBIENT TEMPERATURE																											
		65				75				85				95				105				115							
		59	63	67	71	59	63	67	71	59	63	67	71	59	63	67	71	59	63	67	71	59	63	67	71				
		ENTERING INDOOR WET BULB TEMPERATURE																											
AIRFLOW		59	63	67	71	59	63	67	71	59	63	67	71	59	63	67	71	59	63	67	71	59	63	67	71	59	63	67	71
<b>1490</b>	MBh	56.7	57.5	59.2	-	56.2	57.0	58.7	-	54.7	55.5	57.2	-	52.2	53.0	54.7	-	49.1	49.9	51.6	-	46.3	47.1	48.8	-				
	S/T	0.60	0.53	0.41	-	0.60	0.53	0.41	-	0.62	0.56	0.43	-	0.64	0.57	0.45	-	0.66	0.59	0.47	-	1.00	0.64	0.52	-				
	ΔT	22	20	16	-	22	19	16	-	22	20	16	-	22	19	15	-	21	19	15	-	23	21	17	-				
	KW	3.59	3.59	3.58	-	4.03	4.03	4.02	-	4.52	4.52	4.51	-	5.05	5.05	5.04	-	5.64	5.64	5.63	-	6.34	6.33	6.33	-				
	Amps	13.4	13.4	13.4	-	15.4	15.4	15.4	-	17.7	17.6	17.6	-	20.1	20.1	20.0	-	22.8	22.8	22.7	-	26.0	26.0	25.9	-				
<b>2000</b>	MBh	59.5	60.3	62.0	-	59.0	59.8	61.5	-	57.6	58.4	60.0	-	55.1	55.9	57.5	-	52.0	52.8	54.5	-	49.2	50.0	51.7	-				
	S/T	0.63	0.56	0.44	-	0.64	0.57	0.45	-	0.66	0.59	0.47	-	0.68	0.61	0.49	-	1.00	0.63	0.51	-	1.00	0.67	0.55	-				
	ΔT	19	17	13	-	19	17	13	-	19	17	13	-	19	17	13	-	19	16	13	-	20	18	14	-				
	KW	3.64	3.64	3.63	-	4.08	4.08	4.07	-	4.57	4.57	4.56	-	5.10	5.09	5.09	-	5.69	5.69	5.68	-	6.38	6.38	6.37	-				
	Amps	13.6	13.6	13.6	-	15.6	15.6	15.6	-	17.9	17.9	17.8	-	20.3	20.3	20.3	-	23.0	23.0	23.0	-	26.2	26.2	26.1	-				
<b>2250</b>	MBh	61.5	62.3	64.0	-	61.0	61.8	63.5	-	59.6	60.4	62.0	-	57.0	57.8	59.5	-	54.0	54.8	56.4	-	51.2	52.0	53.6	-				
	S/T	0.60	0.53	0.41	-	0.60	0.54	0.41	-	0.63	0.56	0.44	-	1.00	0.58	0.45	-	1.00	0.60	0.47	-	1.00	0.64	0.52	-				
	ΔT	18	16	12	-	18	16	12	-	18	16	12	-	18	16	12	-	17	15	11	-	19	17	13	-				
	KW	3.66	3.66	3.65	-	4.10	4.10	4.09	-	4.59	4.59	4.58	-	5.12	5.12	5.11	-	5.71	5.71	5.70	-	6.40	6.40	6.39	-				
	Amps	13.7	13.7	13.7	-	15.7	15.7	15.7	-	18.0	18.0	17.9	-	20.4	20.4	20.3	-	23.1	23.1	23.1	-	26.3	26.3	26.2	-				
<b>1490</b>	MBh	56.7	57.5	59.2	61.7	56.2	57.0	58.7	61.2	54.8	55.6	57.2	59.8	52.2	53.0	54.7	57.3	49.2	50.0	51.6	54.2	46.4	47.2	48.8	51.4				
	S/T	0.71	0.64	0.52	0.4	0.72	0.65	0.53	0.4	0.74	0.67	0.55	0.4	1.00	0.69	0.57	0.4	1.00	0.71	0.59	0.5	1.00	0.75	0.63	0.5				
	ΔT	26	24	20	16	26	24	20	16	27	24	20	16	26	24	20	16	26	24	20	16	27	25	21	17				
	KW	3.59	3.59	3.58	3.6	4.03	4.03	4.02	4.1	4.52	4.52	4.51	4.5	5.05	5.04	5.04	5.1	5.64	5.64	5.63	5.7	6.33	6.33	6.32	6.4				
	Amps	13.4	13.4	13.4	13.5	15.4	15.4	15.4	15.5	17.7	17.6	17.6	17.8	20.1	20.1	20.0	20.2	22.8	22.8	22.7	22.9	26.0	25.9	25.9	26.1				
<b>2000</b>	MBh	59.6	60.4	62.0	64.6	59.1	59.9	61.5	64.1	57.6	58.4	60.1	62.6	55.1	<b>55.9</b>	57.6	60.1	52.0	52.8	54.5	57.0	49.2	50.0	51.7	54.2				
	S/T	0.75	0.68	0.56	0.4	0.75	0.68	0.56	0.4	1.00	0.71	0.59	0.5	1.00	<b>0.72</b>	0.60	0.5	1.00	0.74	0.62	0.5	1.00	1.00	0.67	0.5				
	ΔT	24	22	18	13	24	21	17	13	24	22	18	14	24	<b>21</b>	17	13	23	21	17	13	25	22	19	14				
	KW	3.64	3.64	3.63	3.66	4.08	4.07	4.07	4.10	4.57	4.56	4.56	4.59	5.10	<b>5.09</b>	5.08	5.12	5.69	5.68	5.68	5.71	6.38	6.38	6.37	6.40				
	Amps	13.6	13.6	13.6	13.7	15.6	15.6	15.6	15.7	17.9	17.9	17.8	18.0	20.3	<b>20.3</b>	20.2	20.4	23.0	23.0	22.9	23.1	26.2	26.2	26.1	26.3				
<b>2250</b>	MBh	61.6	62.3	64.0	66.6	61.1	61.8	63.5	66.1	59.6	60.4	62.1	64.6	57.1	57.9	59.5	62.1	54.0	54.8	56.5	59.0	51.2	52.0	53.7	56.2				
	S/T	0.71	0.65	0.52	0.4	1.00	0.65	0.53	0.4	1.00	0.67	0.55	0.4	1.00	0.69	0.57	0.4	1.00	0.71	0.59	0.5	1.00	1.00	0.64	0.5				
	ΔT	22	20	16	12	22	20	16	12	23	21	17	13	22	20	16	12	22	20	16	12	23	21	17	13				
	KW	3.66	3.66	3.65	3.7	4.10	4.09	4.09	4.1	4.59	4.58	4.58	4.6	5.12	5.11	5.10	5.1	5.71	5.70	5.70	5.7	6.40	6.40	6.39	6.4				
	Amps	13.7	13.7	13.7	13.8	15.7	15.7	15.7	15.8	18.0	17.9	17.9	18.1	20.4	20.4	20.3	20.5	23.1	23.1	23.0	23.2	26.3	26.2	26.2	26.4				

IDB: Entering Indoor Dry Bulb Temperature  
 High and low pressures are measured at the liquid and suction service valves.  
 Shaded area is ACCA (TVA) conditions.  
 KW=Total system power  
 Amps = outdoor unit amps (Comp.+Fan)

IDB		OUTDOOR AMBIENT TEMPERATURE																							
		65				75				85				95				105				115			
		AIRFLOW		59	63	67	71	59	63	67	71	59	63	67	71	59	63	67	71	59	63	67	71	59	63
<b>1490</b>	MBh	57.0	57.8	59.5	62.0	56.5	57.3	59.0	61.5	55.1	55.8	57.5	60.1	52.5	53.3	55.0	57.6	49.5	50.3	51.9	54.5	46.7	47.5	49.1	51.7
	S/T	0.82	0.76	0.63	0.5	1.00	0.76	0.64	0.5	1.00	0.78	0.66	0.5	1.00	0.80	0.68	0.6	1.00	0.82	0.70	0.6	1.00	1.00	0.75	0.6
	ΔT	31	29	25	21	31	29	25	21	31	29	25	21	31	29	25	21	31	29	25	20	32	30	26	22
	kW	3.59	3.59	3.58	3.6	4.03	4.03	4.02	4.1	4.52	4.52	4.51	4.5	5.05	5.05	5.04	5.1	5.64	5.64	5.63	5.7	6.34	6.33	6.32	6.4
	Amps	13.4	13.4	13.4	13.5	15.4	15.4	15.4	15.5	17.7	17.6	17.6	17.8	20.1	20.1	20.0	20.2	22.8	22.8	22.7	22.9	26.0	26.0	25.9	26.1
<b>2000</b>	MBh	59.9	60.7	62.3	64.9	59.4	60.2	61.8	64.4	57.9	58.7	60.4	62.9	55.4	56.2	<b>57.9</b>	60.4	52.3	53.1	54.8	57.3	49.5	50.3	52.0	54.5
	S/T	1.00	0.79	0.67	0.5	1.00	0.80	0.68	0.5	1.00	0.82	0.70	0.6	1.00	0.84	<b>0.72</b>	0.6	1.00	1.00	0.74	0.6	1.00	1.00	0.78	0.7
	ΔT	28	26	22	18	28	26	22	18	29	26	22	18	28	26	<b>22</b>	18	28	26	22	18	29	27	23	19
	kW	3.64	3.64	3.63	3.66	4.08	4.08	4.07	4.10	4.57	4.57	4.56	4.59	5.10	5.09	<b>5.09</b>	5.12	5.69	5.69	5.68	5.71	6.38	6.38	6.37	6.41
	Amps	13.6	13.6	13.6	13.7	15.6	15.6	15.6	15.7	17.9	17.9	17.8	18.0	20.3	20.3	<b>20.3</b>	20.4	23.0	23.0	23.0	23.1	26.2	26.2	26.1	26.3
<b>2250</b>	MBh	61.8	62.6	64.3	66.9	61.3	62.1	63.8	66.4	59.9	60.7	62.3	64.9	57.4	58.2	59.8	62.4	54.3	55.1	56.8	59.3	51.5	52.3	54.0	56.5
	S/T	1.00	0.76	0.64	0.5	1.00	0.76	0.64	0.5	1.00	0.79	0.66	0.5	1.00	1.00	0.68	0.6	1.00	1.00	0.70	0.6	1.00	1.00	0.75	0.6
	ΔT	27	25	21	17	27	25	21	17	27	25	21	17	27	25	21	17	27	25	21	17	28	26	22	18
	kW	3.66	3.66	3.65	3.7	4.10	4.10	4.09	4.1	4.59	4.59	4.58	4.6	5.12	5.11	5.11	5.1	5.71	5.71	5.70	5.7	6.40	6.40	6.39	6.4
	Amps	13.7	13.7	13.7	13.8	15.7	15.7	15.7	15.8	18.0	18.0	17.9	18.1	20.4	20.4	20.3	20.5	23.1	23.1	23.0	23.2	26.3	26.3	26.2	26.4
<b>1490</b>	MBh	58.0	58.7	60.4	63.0	57.5	58.2	59.9	62.5	56.0	56.8	58.5	61.0	53.5	54.3	55.9	58.5	50.4	51.2	52.9	55.4	47.6	48.4	50.1	52.6
	S/T	1.00	0.85	0.72	0.6	1.00	0.85	0.73	0.6	1.00	1.00	0.75	0.6	1.00	1.00	0.77	0.6	1.00	1.00	0.79	0.7	1.00	1.00	0.84	0.7
	ΔT	35	33	29	25	35	33	29	25	35	33	29	25	35	33	29	25	35	33	29	25	36	34	30	26
	kW	3.60	3.60	3.59	3.6	4.04	4.04	4.03	4.1	4.53	4.53	4.52	4.6	5.06	5.06	5.05	5.1	5.65	5.65	5.64	5.7	6.34	6.34	6.33	6.4
	Amps	13.5	13.4	13.4	13.6	15.5	15.4	15.4	15.6	17.7	17.7	17.7	17.8	20.1	20.1	20.1	20.2	22.8	22.8	22.8	22.9	26.0	26.0	26.0	26.1
<b>2000</b>	MBh	60.8	61.6	63.3	65.8	60.3	61.1	62.8	65.3	58.9	59.6	61.3	63.9	56.3	57.1	58.8	61.4	53.3	54.1	55.7	58.3	50.5	51.2	52.9	55.5
	S/T	1.00	0.88	0.76	0.6	1.00	0.89	0.77	0.6	1.00	1.00	0.79	0.7	1.00	1.00	0.81	0.7	1.00	1.00	0.83	0.7	1.00	1.00	1.00	0.7
	ΔT	32	30	26	22	32	30	26	22	33	31	27	23	32	30	26	22	32	30	26	22	33	31	27	23
	kW	3.65	3.65	3.64	3.67	4.09	4.08	4.08	4.11	4.58	4.57	4.57	4.60	5.11	5.10	5.10	5.13	5.70	5.69	5.69	5.72	6.39	6.39	6.38	6.41
	Amps	13.7	13.7	13.6	13.8	15.7	15.7	15.6	15.8	17.9	17.9	17.9	18.0	20.3	20.3	20.3	20.4	23.0	23.0	23.0	23.1	26.2	26.2	26.2	26.3
<b>2250</b>	MBh	62.8	63.6	65.3	67.8	62.3	63.1	64.8	67.3	60.8	61.6	63.3	65.8	58.3	59.1	60.8	63.3	55.2	56.0	57.7	60.3	52.4	53.2	54.9	57.5
	S/T	1.00	0.85	0.73	0.6	1.00	1.00	0.73	0.6	1.00	1.00	0.76	0.6	1.00	1.00	0.77	0.6	1.00	1.00	1.00	0.7	1.00	1.00	1.00	0.7
	ΔT	31	29	25	21	31	29	25	21	32	29	25	21	31	29	25	21	31	29	25	21	32	30	26	22
	kW	3.67	3.67	3.66	3.7	4.11	4.10	4.10	4.1	4.60	4.59	4.59	4.6	5.13	5.12	5.12	5.1	5.72	5.71	5.71	5.7	6.41	6.41	6.40	6.4
	Amps	13.8	13.8	13.7	13.9	15.8	15.8	15.7	15.9	18.0	18.0	18.0	18.1	20.4	20.4	20.4	20.5	23.1	23.1	23.1	23.2	26.3	26.3	26.3	26.4

IDB: Entering Indoor Dry Bulb Temperature  
 High and low pressures are measured at the liquid and suction service valves.  
 Shaded area is ACCA (TVA) conditions.  
 kW= Total system power  
 Amps = outdoor unit amps (comp.+fan)

**DC3SEA3630A\*/3640A\*+CAPTA3626\***

<b>Conditions: 80 °F IBD, 67 °F IWB @ 1150 CFM</b>				
<b>Outdoor Tem. ° F.</b>	<b>Total BTU/h</b>	<b>Sensible BTU/h</b>	<b>Latent BTU/h</b>	<b>Total Watts</b>
75	36,670	26,290	10,380	2,460
80	36,215	26,415	9,800	2,610
85	35,760	26,540	9,220	2,760
90	34,980	26,295	8,685	2,920
<b>95</b>	<b>34,200</b>	<b>26,050</b>	<b>8,150</b>	<b>3,080</b>
100	33,245	25,680	7,565	3,260
105	32,290	25,310	6,980	3,440
110	31,420	27,930	3,490	3,645
115	30,550	30,550	0	3,850
<b>TVA Conditions @ 95° OD DB, 75° ID DB 63° ID WB</b>				
<b>95°</b>	<b>32,980</b>	<b>25,450</b>	<b>7,530</b>	<b>3,080</b>

**DC3SEA4830A\*/4840A\*+CAPT6030\***

<b>Conditions: 80 °F IBD, 67 °F IWB @1400CFM</b>				
<b>Outdoor Tem. ° F.</b>	<b>Total BTU/h</b>	<b>Sensible BTU/h</b>	<b>Latent BTU/h</b>	<b>Total Watts</b>
75	48,790	33,330	15,460	3,360
80	48,185	33,490	14,695	3,555
85	47,580	33,650	13,930	3,750
90	46,540	33,335	13,205	3,960
<b>95</b>	<b>45,500</b>	<b>33,020</b>	<b>12,480</b>	<b>4,170</b>
100	44,230	32,550	11,680	4,400
105	42,960	32,080	10,880	4,630
110	41,800	32,215	9,585	4,905
115	40,640	32,350	8,290	5,180
<b>TVA Conditions @ 95° OD DB, 75° ID DB 63° ID WB</b>				
<b>95°</b>	<b>43,880</b>	<b>32,270</b>	<b>11,610</b>	<b>4,170</b>

**DC3SEA6030A\*/6040A\*+CAPTA6030\***

<b>Conditions: 80 °F IBD, 67 °F IWB @1490CFM</b>				
<b>Outdoor Tem. ° F.</b>	<b>Total BTU/h</b>	<b>Sensible BTU/h</b>	<b>Latent BTU/h</b>	<b>Total Watts</b>
75	58,970	37,730	21,240	4,020
80	58,240	37,905	20,335	4,265
85	57,510	38,080	19,430	4,510
90	56,255	37,730	18,525	4,775
<b>95</b>	<b>55,000</b>	<b>37,380</b>	<b>17,620</b>	<b>5,040</b>
100	53,465	36,850	16,615	5,335
105	51,930	36,320	15,610	5,630
110	50,525	36,470	14,055	5,975
115	49,120	36,620	12,500	6,320
<b>TVA Conditions @ 95° OD DB, 75° ID DB 63° ID WB</b>				
<b>95°</b>	<b>53,040</b>	<b>36,530</b>	<b>16,510</b>	<b>5,040</b>

***ALL AHRI SYSTEM RATINGS ARE ACCESSIBLE IN THE UNITARY MATCHUP TOOL VIA  
DAIKIN CITY OR IN THE DAIKIN SYSTEM CONFIGURATOR TOOL VIA PARTNERLINK.***

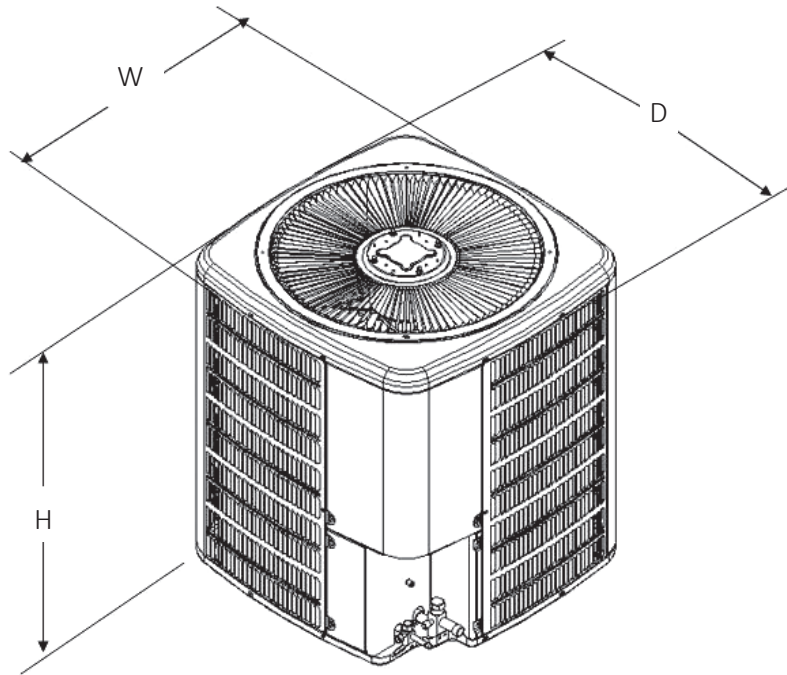

MODEL	DIMENSIONS		
	W	D	H
DC3SEA3630A*	26	26	32½
DC3SEA4830A*	29	29	39½
DC3SEA6030A*	35½	35½	39½
DC3SEA3640A*	26	26	32½
DC3SEA4840A*	29	29	39½
DC3SEA6040A*	35½	35½	39½

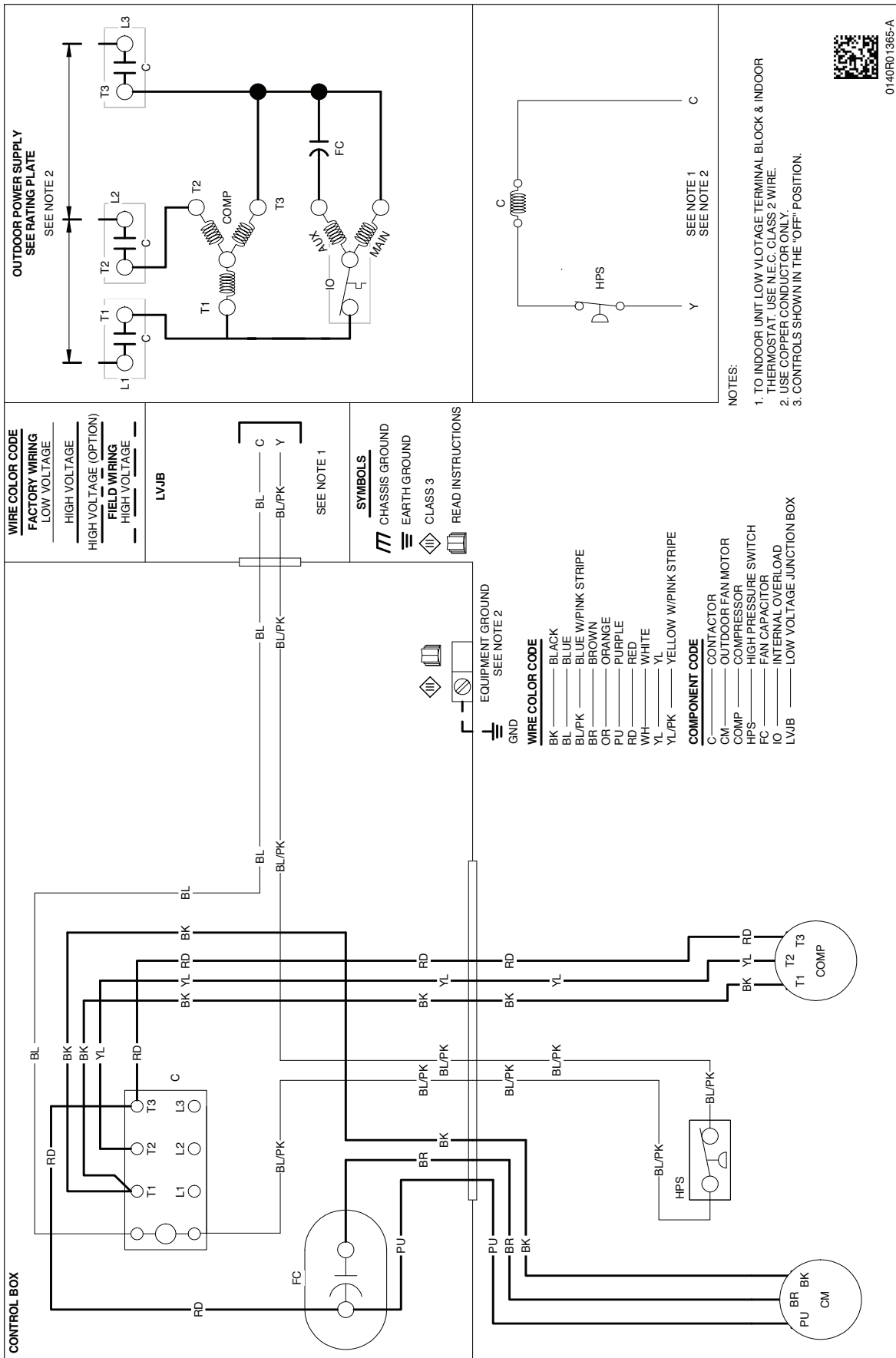

0140R01365-A

Wiring is subject to change. Always refer to the wiring diagram or the unit for the most up-to-date wiring.



**WARNING**

**High Voltage:** Disconnect all power before servicing or installing this unit. Multiple power sources may be present. Failure to do so may cause property damage, personal injury, or death.

MODEL	DESCRIPTION	DC3SEA 3630A*	DC3SEA 4830A*	DC3SEA 6030A*	DC3SEA 3640A*	DC3SEA 4840A*	DC3SEA 6040A*
ABK-20	Anchor Bracket Kit ^	X	X	X	X	X	X
ABK-21	Anchor Bracket Kit ^						
ASC-01	Anti-Short Cycle Kit	X	X	X	X	X	X
FSK01A <sup>1</sup>	Freeze Protection Kit	X	X	X	X	X	X
LSK02B <sup>2</sup>	Liquid Line Solenoid Kit	X	X	X	X	X	X
LAKT01	Low-Ambient Kit	X	X	X	X	X	X
O130R00000S	Low-Pressure Switch Kit	X	X	X	X	X	X

^ Contains 20 brackets; four brackets needed to anchor unit to pad

<sup>1</sup> Installed on indoor coil

<sup>2</sup> Field-installed, non-bleed, expansion valve kit — Condensing units and heat pumps with reciprocating compressors require the use of start-assist components when used in conjunction with an indoor coil using a non-bleed thermal expansion valve refrigerant metering device or liquid line solenoid kit. The TXV should always be sized based on the tonnage of the outdoor unit.



