



**CAPEA / CAPE**  
Cased with EEV



**CAUF**  
Uncased



**CAPF**  
Cased

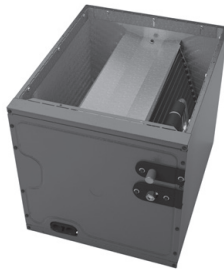

**CAPFA**  
Cased



**CHPF**  
Horizontal "A"

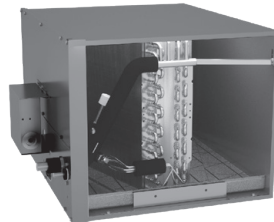

**CHPE**  
Horizontal "A" with EEV



**CSCF**  
Horizontal Slab



**CAPT**  
Cased with Internal TXV

**CAUF, CAPF, CAPT, CHPF,  
CAPEA, CAPE, CHPE AND CSCF  
CASED, PAINTED UPFLOW/DOWNFLOW,  
UNCASED UPFLOW/DOWNFLOW,  
HORIZONTAL "A", AND HORIZONTAL SLAB**

**Standard Features**

- All-Aluminum evaporator coil
- Optimized for use with R-410A refrigerant
- Some models suitable for use with R-410A or R-22 refrigerant
- CAPE, CAPEA and CHPE models feature:
  - Factory-installed electronic expansion valve (EEV) for precise refrigerant control
  - Compatibility with Daikin *One+* smart thermostat and other Daikin communicating equipment
  - Cooling and heat pump applications
  - Fault recall of six most recent faults
- CAPT models feature factory-installed thermal expansion valves for cooling and heat pump applications
- Check flowrator for cooling and heat pump applications
- Vertical and horizontal models available
- 21" depth for easier attic access
- CAPFA/CAPEA models include a single front access panel
- Foil-faced insulation covers the internal casing to reduce cabinet condensation
- Galvanized, leather grain-embossed finish
- Rust resistant, thermoplastic drain pans featuring a low water-retention design
- DecaBDE-free thermoplastic drain pan with secondary drain connections
- UV-resistant drain pan
- AHRI certified; ETL listed



**Note:** Do not use these coils on oil furnaces or any applications where the temperature on the drain pan may exceed 300° F. If these coils are applied with an oil furnace or another application where high temperatures threaten or jeopardize the durability of the drain pan, you must replace the factory-installed drain pan with a high-temperature drain pan. High-temperature drain pan kits are available as field-installed accessories.



\* Complete warranty details available from your local dealer or at [www.daikincomfort.com](http://www.daikincomfort.com). To receive the 12-Year Parts Limited Warranty, online registration must be completed within 60 days of installation. Online registration is not required in California or Québec.

**NOMENCLATURE**

	C	A	U	F	1824	A	6	AA		
	1	2	3	4	5,6,7,8	9	10	11, 12		
<b>Product Category</b>	<div style="display: flex; justify-content: space-between;"> <div style="width: 45%;"> <p>C Indoor Coil</p> <p><b>Application</b></p> <p>A Upflow/Downflow Coil</p> <p>H Horizontal A Coil</p> <p>S Horizontal Slab Coil</p> <p><b>Cabinet Finish</b></p> <p>U Uncased</p> <p>P Cased - Painted</p> <p>C Cased - Unpainted</p> <p><b>Expansion Device</b></p> <p>F Flowrater</p> <p>T TXV</p> <p>E Electronic Expansion Valve</p> </div> <div style="width: 45%;"> <p><b>Engineering</b></p> <p>Major/ Minor Revisions</p> <p><b>Refrigerant</b></p> <p>6 - R-22 / R-410A</p> <p>4 - R-410A</p> <p><b>Nominal Width for Gas Furnace</b></p> <p>A - Fits 14" Furnace Cabinet</p> <p>B - Fits 17½" Furnace Cabinet</p> <p>C - Fits 21" Furnace Cabinet</p> <p>D - Fits 24½" Furnace Cabinet</p> <p>N-Does Not Apply (horizontal slab coil)</p> </div> </div>									
<b>Nominal Capacity Range</b>										
									1824 - 1½ to 2 Tons	3642 - 3 to 3½ Tons
									3030 - 2½ Tons	3743 - 3 to 3½ Tons
									3131 - 2½ Tons	4860 - 4 to 5 Tons
									3137 - 2½ to 3 Tons	4961 - 4 to 5 Tons
									3636 - 3 Tons	

	C	A	P	E	A	18	14	A	6	A	A			
	1	2	3	4	5	6	7	8	9	10	11	12 13		
<b>Product Category</b>	<div style="display: flex; justify-content: space-between;"> <div style="width: 45%;"> <p>C Indoor Coil</p> <p><b>Application</b></p> <p>A Upflow/Downflow Coil</p> <p>H Horizontal A Coil</p> <p>S Horizontal Slab Coil</p> <p><b>Cabinet Finish</b></p> <p>U Uncased</p> <p>P Cased - Painted</p> <p>C Cased - Unpainted</p> <p><b>Expansion Device</b></p> <p>F Flowrater</p> <p>T TXV</p> <p>E Electronic Expansion Valve</p> <p><b>Coil Configuration</b></p> <p>A A Coil</p> <p>S Slab</p> </div> <div style="width: 45%;"> <p><b>Engineering</b></p> <p>Major/ Minor Revisions</p> <p><b>Refrigerant</b></p> <p>4 - R-410A only</p> <p><b>Nominal Width for Gas Furnace</b></p> <p>A - 14" Width      D - 24.5" Width</p> <p>B - 17.5" Width      N - Not Applicable (Slab Coil)</p> <p>C - 21" Width</p> <p><b>Cased Height</b></p> <p>14 - 14" Coil      22 - 22" Coil</p> <p>18 - 18" Coil      26 - 26" Coil</p> <p>30 - 30" Coil</p> </div> </div>													
<b>Nominal Capacity Range</b>														
												17, 18 - 1½ - 2 Tons	29, 30 - 2 - 3 Tons	42 - 3 - 3½ Tons
												23, 24 - 1½ - 2½ Tons	35, 36 - 2 - 3 Tons	48 - 4 Tons
														60 - 5 Tons

# CAUF — UNCASSED UPFLOW/DOWNFLOW INDOOR COILS



## SPECIFICATIONS

MODEL	DIMENSIONS			NOMINAL TONS	CONNECTION		PISTON SIZE* (IN.)	SHIP WEIGHT (LBS)
	W	H	A		LIQUID	SUCTION		
CAUF1824A6	13"	16½"	13"	1½-2	⅜"	¾"	.059	18
CAUF1824B6	16½"	16½"	13"	1½-2	⅜"	¾"	.059	23
CAUF1824C6	20"	16¾"	17"	1½-2	⅜"	¾"	.059	27
CAUF3030A6	13"	20⅞"	17"	2½	⅜"	¾"	.065	25
CAUF3030B6	16½"	18¾"	17"	2½	⅜"	¾"	.065	22
CAUF3030C6	20"	17¾"	17"	2½	⅜"	¾"	.065	25
CAUF3030D6	23"	17¾"	17"	2½	⅜"	¾"	.065	32
CAUF3131B6	16½"	20⅞"	17"	2½	⅜"	¾"	.068	27
CAUF3131B6	16½"	27"	25"	2½-3	⅜"	¾"	.071	53
CAUF3131C6	20"	20"	17"	2½	⅜"	¾"	.068	31
CAUF3636A6	13"	19½"	17"	3	⅜"	¾"	.071	30
CAUF3636B6	16½"	19¾"	17"	3	⅜"	¾"	.071	25
CAUF3636C6	20"	19¾"	17"	3	⅜"	¾"	.071	28
CAUF3636D6	23"	19¾"	17"	3	⅜"	¾"	.071	36
CAUF3642C6	20"	19"	17"	3-3½	⅜"	¾"	.078	29
CAUF3642D6	23"	19¾"	17"	3-3½	⅜"	¾"	.078	34
CAUF3743C6	20"	28⅞"	25"	3-3½	⅜"	⅞"	.078	46
CAUF3743D6	23"	27¾"	25"	3-3½	⅜"	⅞"	.078	43
CAUF4860C6	20"	28"	25"	4-5	⅜"	⅞"	.093	48
CAUF4860D6	23"	28"	25"	4-5	⅜"	⅞"	.093	39
CAUF4961C6	20"	28"	25"	4-5	⅜"	⅞"	.093	54
CAUF4961D6	23"	27"	25"	4-5	⅜"	⅞"	.093	59

\* Shipped with Coil

Note: For a properly matched system and piston sizing information, refer to Daikin piston kit chart of the corresponding Daikin outdoor unit.

## DIMENSIONS

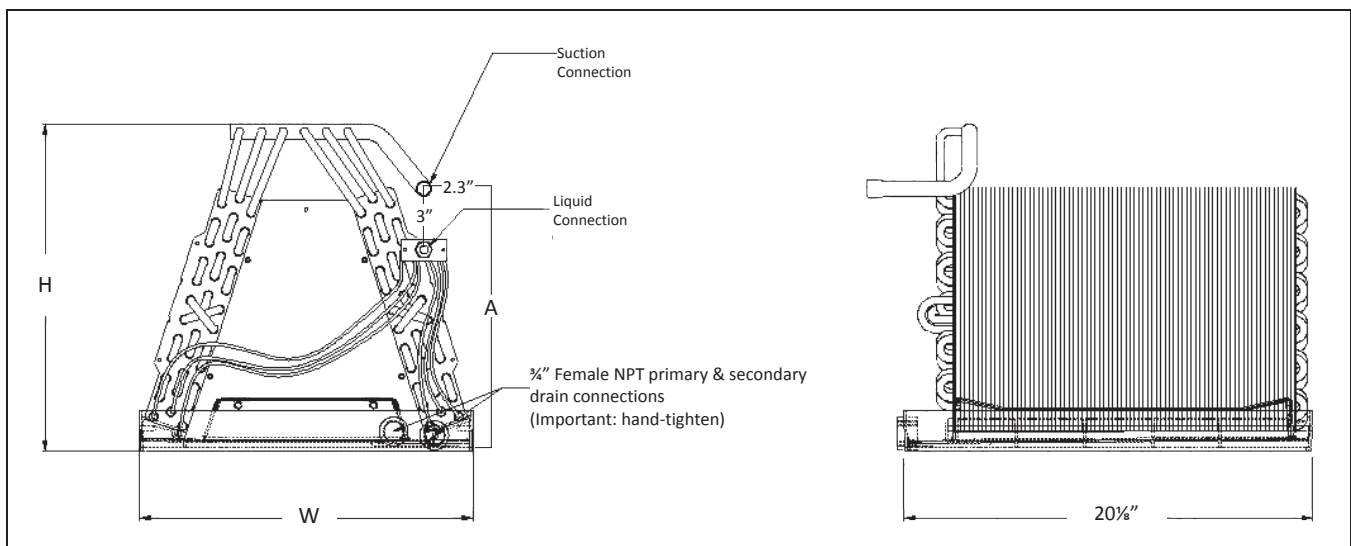

# CAUFA — UNCASSED UPFLOW/DOWNFLOW INDOOR COILS



## SPECIFICATIONS

MODEL	DIMENSIONS				NOMINAL TONS	CONNECTION		PISTON SIZE* (IN.)	SHIP WEIGHT (LBS)
	W	D	H	A		LIQUID	SUCTION		
CAUFA1714A6	12½"	20⅝"	11¼"	6"	1½	⅜"	¼"	0.051	16
CAUFA1714B6	16"	20⅝"	11"	6"	1½	⅜"	¼"	0.051	18
CAUFA1818A6	12½"	20⅝"	14¾"	12¾"	1½	⅜"	¼"	0.055	18
CAUFA1818B6	16"	20⅝"	14½"	12¾"	1½	⅜"	¼"	0.055	20
CAUFA1818C6	19½"	20⅝"	14¾"	12¾"	1½	⅜"	¼"	0.055	26
CAUFA2318A6	12½"	20⅝"	14¾"	12¾"	2	⅜"	¼"	0.057	18
CAUFA2318B6	16"	20⅝"	14½"	12¾"	2	⅜"	¼"	0.057	20
CAUFA2318C6	19½"	20⅝"	14¾"	12¾"	2	⅜"	¼"	0.057	26
CAUFA2418A6	12½"	20⅝"	14¾"	12¾"	2	⅜"	¼"	0.057	18
CAUFA2418B6	16"	20⅝"	14½"	12¾"	2	⅜"	¼"	0.057	20
CAUFA2418C6	19½"	20⅝"	14¾"	12¾"	2	⅜"	¼"	0.057	26
CAUFA2422A6	12½"	20⅝"	18"	17"	2	⅜"	¼"	0.059	26
CAUFA2422B6	16"	20⅝"	17¾"	16¾"	2	⅜"	¼"	0.059	28
CAUFA2422C6	19½"	20⅝"	17½"	16¾"	2	⅜"	¼"	0.059	30
CAUFA2922A6	12½"	20⅝"	18"	17"	2½	⅜"	¼"	0.065	26
CAUFA2922B6	16"	20⅝"	17¾"	16¾"	2½	⅜"	¼"	0.065	28
CAUFA2922C6	19½"	20⅝"	17¾"	16¾"	2½	⅜"	¼"	0.065	30
CAUFA3022A6	12½"	20⅝"	18"	17"	2½	⅜"	¼"	0.063	26
CAUFA3022B6	16"	20⅝"	17¾"	16¾"	2½	⅜"	¼"	0.063	28
CAUFA3022C6	19½"	20⅝"	17½"	16¾"	2½	⅜"	¼"	0.063	30
CAUFA3022D6	23"	20⅝"	17¾"	16¾"	2½	⅜"	¼"	0.063	32
CAUFA3526B6	16"	20⅝"	21"	20¾"	3	⅜"	⅞"	0.065	30
CAUFA3526C6	19½"	20⅝"	20¾"	20¾"	3	⅜"	⅞"	0.065	31
CAUFA3626B6	16"	20⅝"	21"	20¾"	3	⅜"	⅞"	0.065	30
CAUFA3626C6	19½"	20⅝"	20¾"	20¾"	3	⅜"	⅞"	0.065	31
CAUFA3626D6	23"	20⅝"	20¾"	20¾"	3	⅜"	⅞"	0.065	35
CAUFA4226B6	16"	20⅝"	24¾"	20¾"	3½	⅜"	⅞"	0.071	28
CAUFA4226C6	19½"	20⅝"	24"	20¾"	3½	⅜"	⅞"	0.071	30
CAUFA4226D6	23"	20⅝"	23¾"	20¾"	3½	⅜"	⅞"	0.071	33

\* Shipped with Coil

Note: For a properly matched system and piston sizing information, refer to Daikin piston kit chart of the corresponding Daikin outdoor unit.

## DIMENSIONS

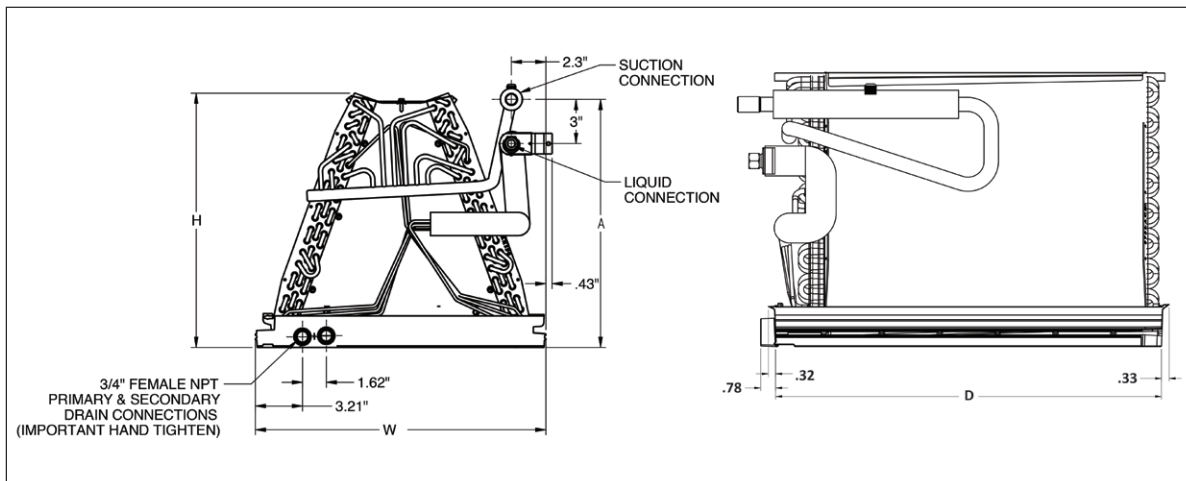

# CAPFA — CASED UPFLOW/DOWNFLOW INDOOR COILS



## SPECIFICATIONS

MODEL	CABINET DIMENSIONS				NOMINAL TONS	CONNECTION		PISTON SIZE* (IN.)	SHIP WEIGHT (LBS)
	W	D	H	A		LIQUID	SUCTION		
CAPFA1714A6	14"	21"	14"	6"	1½	⅜"	¼"	0.051	29
CAPFA1714B6	17½"	21"	14"	6"	1½	⅜"	¼"	0.051	33
CAPFA1818A6	14"	21"	18"	14"	1½	⅜"	¼"	0.055	33
CAPFA1818B6	17½"	21"	18"	14"	1½	⅜"	¼"	0.055	38
CAPFA1818C6	21"	21"	18"	14"	1½	⅜"	¼"	0.055	43
CAPFA2318A6	14"	21"	18"	14"	2	⅜"	¼"	0.057	33
CAPFA2318B6	17½"	21"	18"	14"	2	⅜"	¼"	0.057	38
CAPFA2318C6	21"	21"	18"	14"	2	⅜"	¼"	0.057	43
CAPFA2418A6	14"	21"	18"	14"	2	⅜"	¼"	0.057	33
CAPFA2418B6	17½"	21"	18"	14"	2	⅜"	¼"	0.057	38
CAPFA2418C6	21"	21"	18"	14"	2	⅜"	¼"	0.057	43
CAPFA2422A6	14"	21"	22"	18"	2	⅜"	¼"	0.059	41
CAPFA2422B6	17½"	21"	22"	18"	2	⅜"	¼"	0.059	45
CAPFA2422C6	21"	21"	22"	18"	2	⅜"	¼"	0.059	50
CAPFA2922A6	14"	21"	22"	18"	2½	⅜"	¼"	0.065	41
CAPFA2922B6	17½"	21"	22"	18"	2½	⅜"	¼"	0.065	45
CAPFA2922C6	21"	21"	22"	18"	2½	⅜"	¼"	0.065	50
CAPFA3022A6	14"	21"	22"	18"	2½	⅜"	¼"	0.063	41
CAPFA3022B6	17½"	21"	22"	18"	2½	⅜"	¼"	0.063	45
CAPFA3022C6	21"	21"	22"	18"	2½	⅜"	¼"	0.063	50
CAPFA3022D6	24½"	21"	22"	18"	2½	⅜"	¼"	0.063	52
CAPFA3526B6	17½"	21"	26"	22"	3	⅜"	⅞"	0.065	47
CAPFA3526C6	21"	21"	26"	22"	3	⅜"	⅞"	0.065	49
CAPFA3626B6	17½"	21"	26"	22"	3	⅜"	⅞"	0.065	47
CAPFA3626C6	21"	21"	26"	22"	3	⅜"	⅞"	0.065	49
CAPFA3626D6	24½"	21"	26"	22"	3	⅜"	⅞"	0.065	56
CAPFA4226B6	17½"	21"	26"	22"	3½	⅜"	⅞"	0.071	51
CAPFA4226C6	21"	21"	26"	22"	3½	⅜"	⅞"	0.071	54
CAPFA4226D6	24½"	21"	26"	22"	3½	⅜"	⅞"	0.071	59

## DIMENSIONS

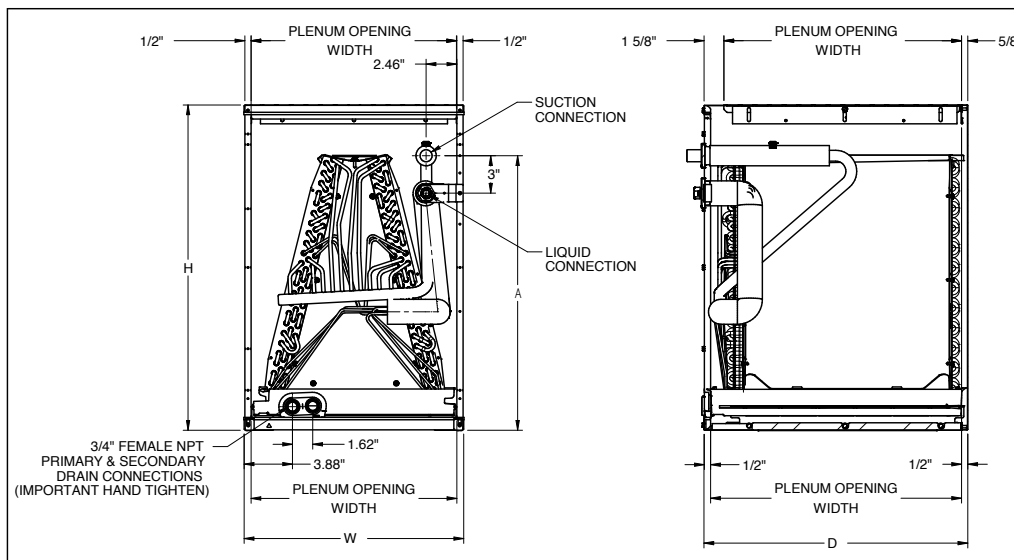

# CAPF — CASED UPFLOW/DOWNFLOW INDOOR COILS



## SPECIFICATIONS

MODEL	CABINET DIMENSIONS			NOMINAL TONS	CONNECTION		PISTON SIZE* (IN.)	SHIP WEIGHT (LBS)
	W	D	H		LIQUID	SUCTION		
CAPF1824A6	14"	21"	18"	1½-2	⅜"	¼"	.059	32
CAPF1824B6	17½"	21"	18"	1½-2	⅜"	¼"	.059	35
CAPF1824C6	21"	21"	22"	1½-2	⅜"	¼"	.059	42
CAPF3030A6	14"	21"	22"	2½	⅜"	¼"	.065	41
CAPF3030B6	17½"	21"	22"	2½	⅜"	¼"	.065	43
CAPF3030C6	21"	21"	22"	2½	⅜"	¼"	.065	44
CAPF3030D6	24½"	21"	22"	2½	⅜"	¼"	.065	52
CAPF3131B6	17½"	21"	22"	2½	⅜"	¼"	.068	46
CAPF3137B6	17½"	21"	30"	2½-3	⅜"	¼"	.071	53
CAPF3131C6	21"	21"	22"	2½	⅜"	¼"	.068	50
CAPF3636A6	14"	21"	22"	3	⅜"	¼"	.071	40
CAPF3636B6	17½"	21"	22"	3	⅜"	¼"	.071	44
CAPF3636C6	21"	21"	22"	3	⅜"	¼"	.071	53
CAPF3636D6	24½"	21"	22"	3	⅜"	¼"	.071	51
CAPF3642C6	21"	21"	22"	3-3½	⅜"	¼"	.078	49
CAPF3642D6	24½"	21"	22"	3-3½	⅜"	¼"	.078	52
CAPF3743C6	21"	21"	30"	3-3½	⅜"	⅞"	.078	63
CAPF3743D6	24½"	21"	30"	3-3½	⅜"	⅞"	.078	75
CAPF4860C6	21"	21"	30"	4-5	⅜"	⅞"	.093	65
CAPF4860D6	24½"	21"	30"	4-5	⅜"	⅞"	.093	68
CAPF4961C6	21"	21"	30"	4-5	⅜"	⅞"	.093	73
CAPF4961D6	24½"	21"	30"	4-5	⅜"	⅞"	.093	76

\* Shipped with Coil

Note: For a properly matched system and piston sizing information, refer to Daikin piston kit chart of the corresponding Daikin outdoor unit.

## DIMENSIONS

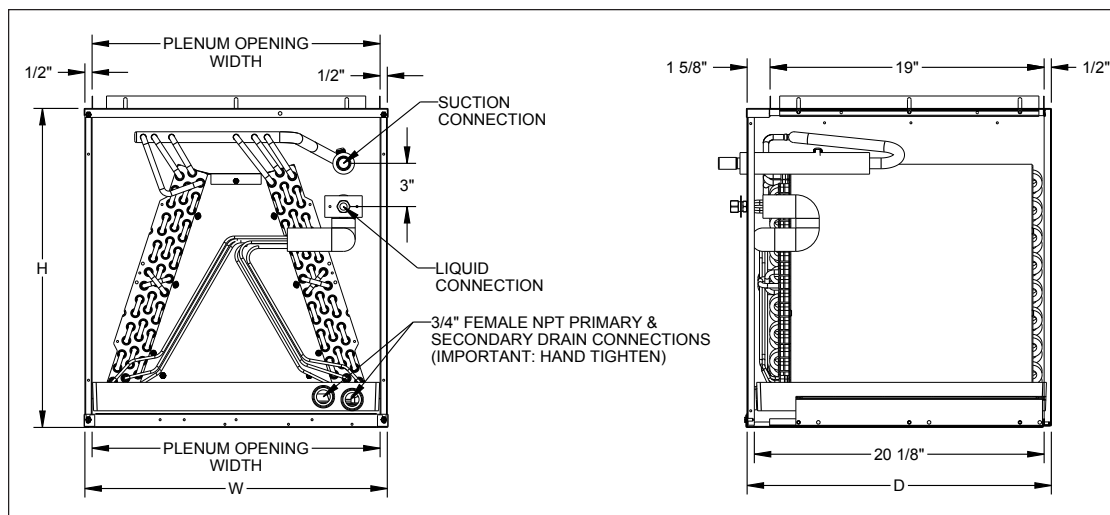

# CAPEA / CAPE — CASED UPFLOW/DOWNFLOW INDOOR COILS



## SPECIFICATIONS

MODEL	CABINET DIMENSIONS			NOMINAL TONS	CONNECTION		SHIP WEIGHT (LBS)
	W	D	H		LIQUID	SUCTION	
CAPEA1818B4	17½"	21"	18"	1½-2	¾"	¾"	43
CAPEA1818C4	21"	21"	18"	1½-2	¾"	¾"	45
CAPEA2422B4	17½"	21"	22"	2-2½	¾"	¾"	48
CAPEA2422C4	21"	21"	22"	2-2½	¾"	¾"	51
CAPEA3026B4	17½"	21"	26"	3	¾"	7/8"	54
CAPEA3026C4	21"	21"	26"	3	¾"	7/8"	57
CAPEA3026D4	24½"	21"	26"	3	¾"	7/8"	62

MODEL	CABINET DIMENSIONS			NOMINAL TONS	CONNECTION		SHIP WEIGHT (LBS)
	W	D	H		LIQUID	SUCTION	
CAPE4860C4	21"	21"	30"	3½-4	¾"	7/8"	71
CAPE4860D4	24½"	21"	30"	3½-4	¾"	7/8"	73
CAPE4961C4	21"	21"	30"	4-5	¾"	7/8"	78
CAPE4961D4	24½"	21"	30"	4-5	¾"	7/8"	80

## DIMENSIONS

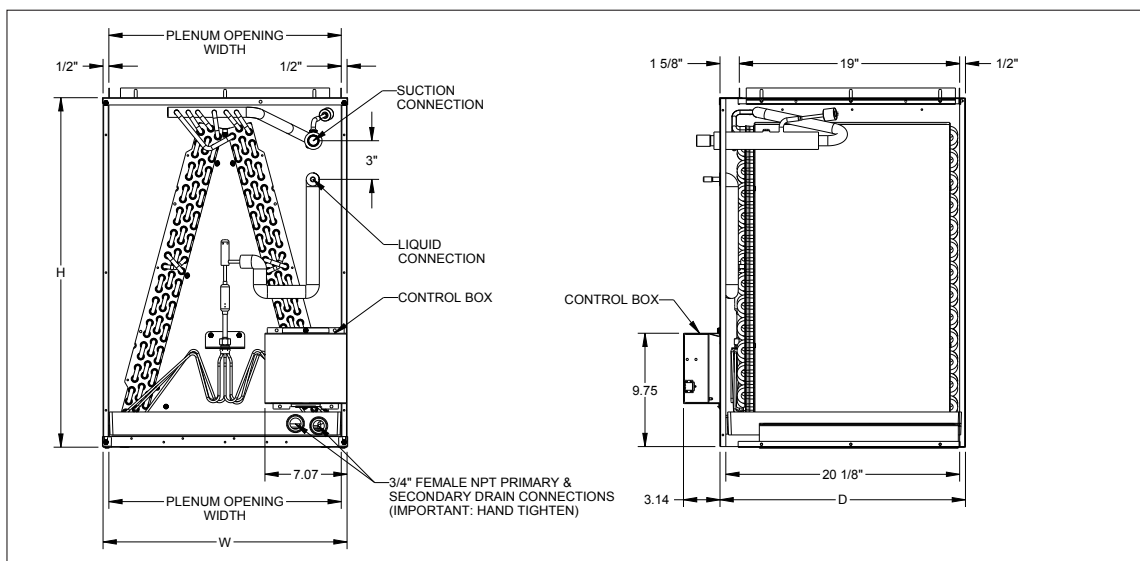
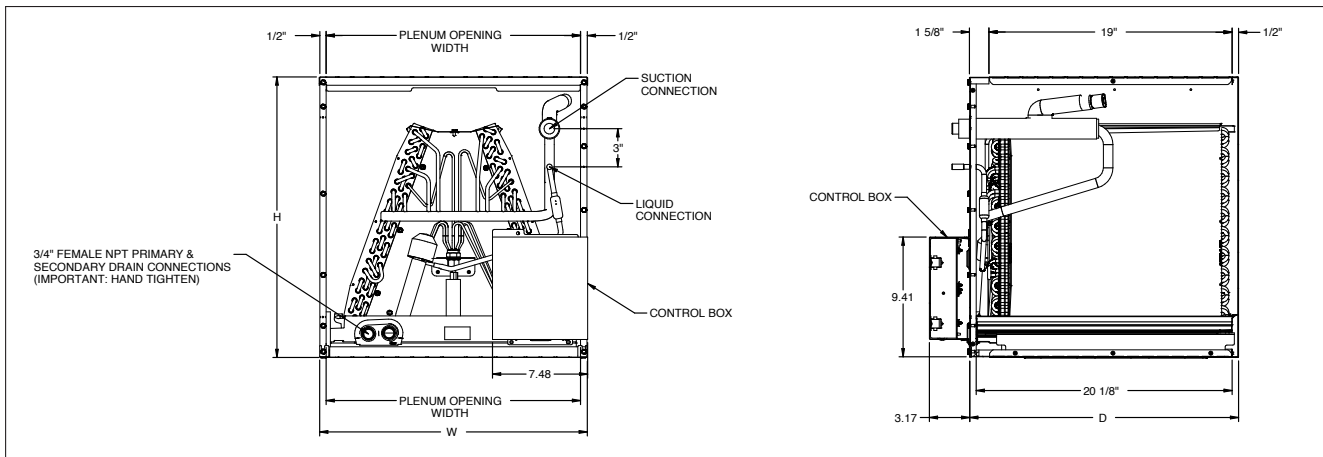



# CAPT — CASED UPFLOW/DOWNFLOW INDOOR COILS WITH INTERNAL TXV

## SPECIFICATIONS

MODEL	CABINET DIMENSIONS			NOMINAL TONS	CONNECTION		SHIP WEIGHT (LBS)
	W	D	H		LIQUID	SUCTION	
CAPT3131B4	17½"	21"	22"	2½	¾"	¾"	46
CAPT3131C4	21"	21"	22"	2½	¾"	¾"	50
CAPT3743C4	21"	21"	30"	3-3½	¾"	7/8"	63
CAPT3743D4	24½"	21"	30"	3-3½	¾"	7/8"	75
CAPT4961C4	21"	21"	30"	4-5	¾"	7/8"	73
CAPT4961D4	24½"	21"	30"	4-5	¾"	7/8"	76

## DIMENSIONS

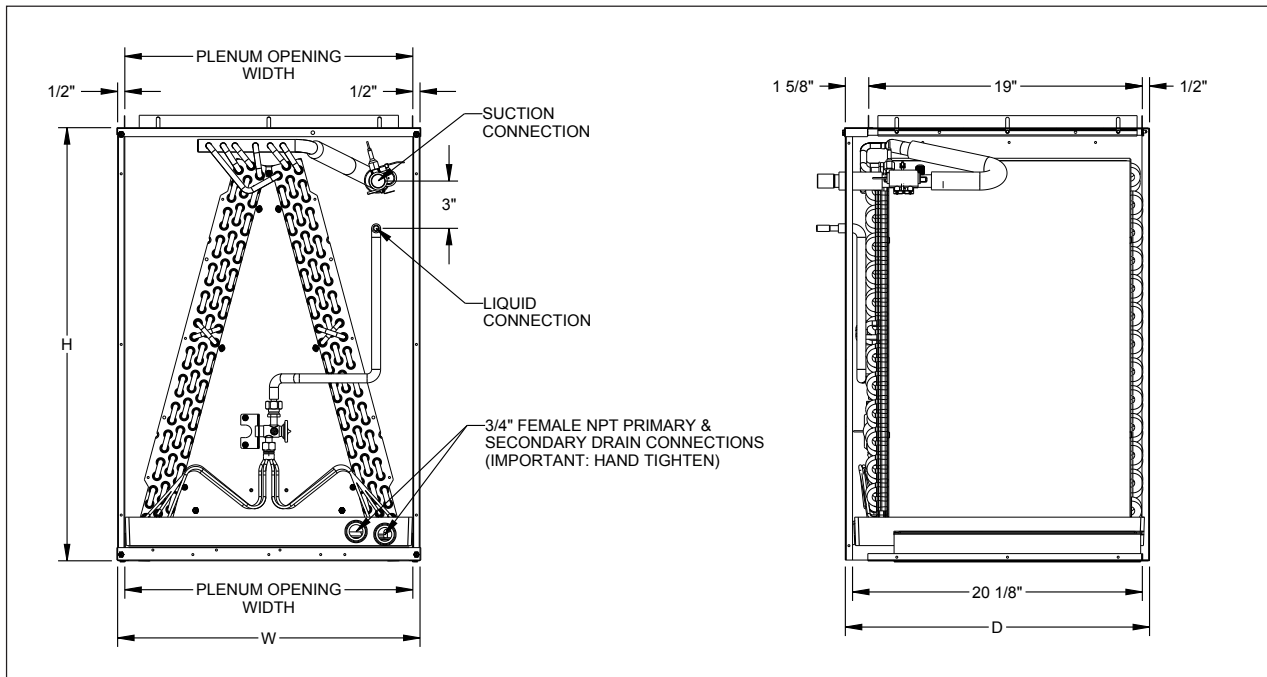



# CHPF, CHPE — PAINTED CASED HORIZONTAL “A” INDOOR COIL



## SPECIFICATIONS

MODEL	CABINET DIMENSIONS			PLENUM		NOMINAL TONS	CONNECTION		PISTON SIZE (IN.) <sup>2</sup>	SHIP WEIGHT (LBS)
	D	W	H	D	H		LIQUID	SUCTION		
CHPF1824A6	21½"	26"	14"	19"	13"	1½-2	⅜"	¼"	.059	36
CHPF2430B6	21½"	26"	17½"	19"	16½"	2-2½	⅜"	¼"	.065	55
CHPF3636B6	21½"	26"	17½"	19"	16½"	3	⅜"	¼"	.074	50
CHPF3642C6	21½"	26"	21"	19"	20"	3-3½	⅜"	¼"	.076	63
CHPF3743C6	21½"	26"	21"	19"	20"	3-3½	⅜"	⅝"	.076	63
CHPF4860D6	21½"	26"	24½"	19"	23½"	4-5	⅜"	⅞"	.093	77

<sup>1</sup> (ft<sup>2</sup>)

<sup>2</sup> Shipped with Coil

Note: For a properly matched system and piston sizing information, refer to Daikin piston kit chart of the corresponding Daikin outdoor unit.

MODEL	CABINET DIMENSIONS			PLENUM		NOMINAL TONS	CONNECTION		PISTON SIZE (IN.) <sup>2</sup>	SHIP WEIGHT (LBS)
	D	W	H	D	H		LIQUID	SUCTION		
CHPE2430B4	21½"	26"	17½"	19"	16½"	1½	⅜"	¼"	N/A	56
CHPE3636B4	21½"	26"	17½"	19"	16½"	2-3	⅜"	¼"	N/A	59
CHPE3642C4	21½"	26"	21"	19"	20"	2-2 ½	⅜"	¼"	N/A	62
CHPE3743C4	21½"	26"	21"	19"	20"	3-4	⅜"	⅞"	N/A	68
CHPE3743D4	21½"	26"	24½"	19"	23½"	3-3½	⅜"	⅞"	N/A	72
CHPE4860D4	21½"	26"	24½"	19"	23½"	4-5	⅜"	⅞"	N/A	79

## DIMENSIONS

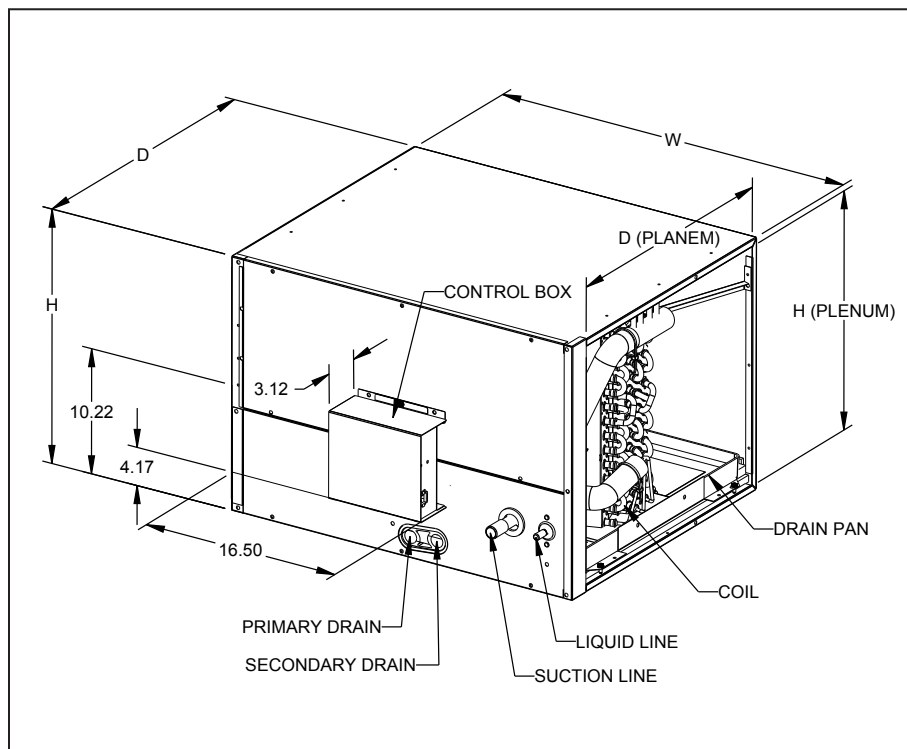

# CSCF — HORIZONTAL SLAB EVAPORATOR COILS



## SPECIFICATIONS

MODEL	CAPACITY (TONS)	EVAP COIL FACE AREA <sup>1</sup>	CONNECTION SIZE		PISTON SIZE (IN.) <sup>2</sup>	SHIP WEIGHT (LBS)
			LIQUID	SUCTION		
CSCF1824N6	1½-2	3½	¾"	¾"	.059	43
CSCF3036N6	2½-3	4½	¾"	7/8"	.074	52.5
CSCF3642N6	3-3½	5½	¾"	7/8"	.078	43
CSCF4860N6	4-5	5½	¾"	7/8"	.093	60

<sup>1</sup> (ft<sup>2</sup>)

<sup>2</sup> Shipped with Coil

Note: For a properly matched system and piston sizing information, refer to Daikin piston kit chart of the corresponding Daikin outdoor unit.

## DIMENSIONS

MODEL	CABINET DIMENSIONS			PLENUM OPENING	
	D (A)	W	H	D (B)	H
CSCF1824N6	25½"	12"	25"	16"	21"
CSCF3036N6	33½"	12"	25"	24"	21"
CSCF3642N6	39½"	12"	25"	30"	21"
CSCF4860N6	39½"	12"	25"	30"	21"

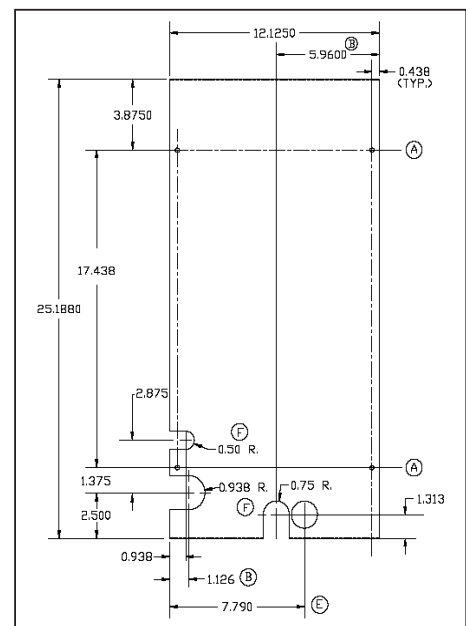
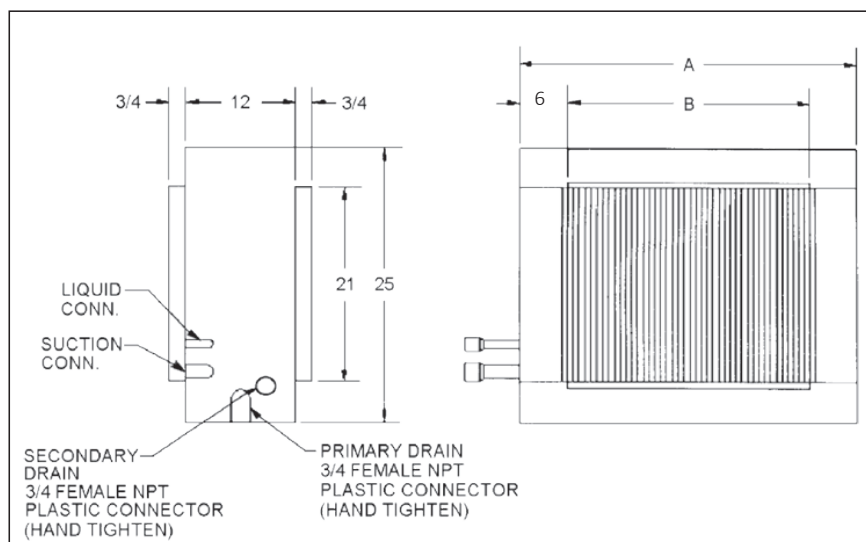

DETAIL OF ACCESS DOOR

# AIRFLOW DATA FOR CAUF, CAUFA & CAPF, CAPFA & CAPEA & CAPE

## AIR QUANTITY (SCFM) VS. PRESSURE DROP (IN. WC)

	SCFM	400	500	600	700	800	900	1000	1100	1200	1300	1400	1500
CA*F1824A6*	Wet	0.071	0.099	0.142	0.183	0.230	0.280	0.331	0.389	---	---	---	---
	Dry	0.062	0.090	0.122	0.154	0.189	0.231	0.278	0.331	0.390	---	---	---
CA*F1824B6*	Wet	0.021	0.032	0.049	0.071	0.089	0.120	0.128	0.159	0.190	---	---	---
	Dry	0.011	0.022	0.029	0.041	0.052	0.069	0.078	0.101	0.120	---	---	---
CA*F1824C6*	Wet	0.017	0.025	0.043	0.061	0.079	0.107	0.114	0.140	0.164	---	---	---
	Dry	0.011	0.017	0.024	0.035	0.044	0.063	0.075	0.094	0.113	---	---	---
CA*FA1714A6*	Wet	0.120	0.180	0.250	0.330	0.410	0.500	0.600	0.710	0.820	---	---	---
	Dry	0.100	0.150	0.200	0.270	0.340	0.420	0.520	0.610	0.720	---	---	---
CA*FA1714B6*	Wet	0.100	0.150	0.210	0.280	0.340	0.420	0.500	0.580	0.660	---	---	---
	Dry	0.080	0.130	0.170	0.230	0.290	0.360	0.420	0.500	0.650	---	---	---
CA*FA1818A6*/ CA*FA2318B6*/ CAPEA1818B4*	Wet	0.110	0.160	0.220	0.290	0.370	0.460	0.550	0.650	0.760	0.830	0.950	1.080
	Dry	0.074	0.100	0.132	0.168	0.220	0.264	0.317	0.377	0.434	0.503	0.584	0.667
CA*FA1818B6*/ CA*FA2318C6*/ CAPEA1818C4*	Wet	0.100	0.140	0.190	0.250	0.310	0.380	0.450	0.530	0.610	0.670	0.770	0.870
	Dry	0.066	0.087	0.115	0.144	0.175	0.218	0.260	0.301	0.347	0.401	0.460	0.521
CA*FA1818C6*/ CA*FA2318C6*/ CAPEA1818C4*	Wet	0.093	0.130	0.172	0.221	0.275	0.335	0.400	0.471	0.548	0.631	0.719	0.813
	Dry	0.064	0.086	0.110	0.139	0.170	0.205	0.243	0.284	0.328	0.376	0.427	0.481
CA*FA2422A6*	Wet	0.091	0.128	0.181	0.240	0.304	0.374	0.454	0.541	0.635	0.733	0.837	0.958
	Dry	0.084	0.112	0.148	0.191	0.241	0.299	0.366	0.440	0.522	0.611	0.704	0.803
CA*FA2422B6*/ CAPEA2422B4*	Wet	0.084	0.117	0.155	0.199	0.249	0.304	0.364	0.430	0.502	0.578	0.661	0.748
	Dry	0.055	0.077	0.102	0.130	0.162	0.196	0.234	0.276	0.320	0.368	0.419	0.473
CA*FA2422C6*/ CAPEA2422C4*	Wet	0.064	0.091	0.120	0.153	0.189	0.228	0.269	0.314	0.361	0.411	0.464	0.520
	Dry	0.055	0.074	0.095	0.119	0.146	0.175	0.207	0.242	0.280	0.320	0.363	0.408
CA*FA2922A6*	Wet	0.091	0.128	0.181	0.240	0.304	0.374	0.454	0.541	0.635	0.733	0.837	0.958
	Dry	0.084	0.112	0.148	0.191	0.241	0.299	0.366	0.440	0.522	0.611	0.704	0.803
CA*FA2922B6*/ CA*FA2922C6*	Wet	0.084	0.117	0.155	0.199	0.249	0.304	0.364	0.430	0.502	0.578	0.661	0.748
	Dry	0.055	0.077	0.102	0.130	0.162	0.196	0.234	0.276	0.320	0.368	0.419	0.473
CA*FA3022A6*	Wet	0.064	0.091	0.120	0.153	0.189	0.228	0.269	0.314	0.361	0.411	0.464	0.520
	Dry	0.055	0.074	0.095	0.119	0.146	0.175	0.207	0.242	0.280	0.320	0.363	0.408
CA*FA3022B6*/ CA*FA3022C6*	Wet	0.091	0.128	0.181	0.240	0.304	0.374	0.454	0.541	0.635	0.733	0.837	0.958
	Dry	0.084	0.112	0.148	0.191	0.241	0.299	0.366	0.440	0.522	0.611	0.704	0.803
CA*FA3022D6*	Wet	0.084	0.117	0.155	0.199	0.249	0.304	0.364	0.430	0.502	0.578	0.661	0.748
	Dry	0.055	0.077	0.102	0.130	0.162	0.196	0.234	0.276	0.320	0.368	0.419	0.473
CA*FA3626B6*/ CAPEA3026B4*	Wet	0.064	0.091	0.120	0.153	0.189	0.228	0.269	0.314	0.361	0.411	0.464	0.520
	Dry	0.055	0.074	0.095	0.119	0.146	0.175	0.207	0.242	0.280	0.320	0.363	0.408
CA*FA3626C6*/ CAPEA3026C4*	Wet	0.064	0.089	0.118	0.149	0.184	0.222	0.262	0.306	0.353	0.402	0.455	0.511
	Dry	0.055	0.072	0.092	0.114	0.139	0.167	0.198	0.231	0.267	0.306	0.348	0.392
CA*FA3626D6*/ CAPEA3026D4*	Wet	0.067	0.085	0.109	0.136	0.167	0.203	0.244	0.288	0.337	0.390	0.447	0.508
	Dry	0.045	0.061	0.080	0.103	0.130	0.159	0.193	0.229	0.269	0.313	0.360	0.410
CA*FA3626E6*/ CAPEA3026E4*	Wet	0.057	0.079	0.103	0.132	0.163	0.199	0.237	0.280	0.325	0.374	0.427	0.483
	Dry	0.041	0.056	0.072	0.091	0.112	0.134	0.159	0.185	0.214	0.245	0.277	0.312
CA*FA3626F6*/ CAPEA3026F4*	Wet	0.055	0.076	0.099	0.124	0.152	0.182	0.215	0.250	0.288	0.328	0.370	0.415
	Dry	0.042	0.055	0.070	0.088	0.108	0.130	0.154	0.180	0.208	0.239	0.271	0.306



## AIRFLOW DATA FOR CAUF, CAUFA & CAPF, CAPFA & CAPEA & CAPE (CONT.)

### AIR QUANTITY (SCFM) VS. PRESSURE DROP (IN. WC)

	SCFM	800	900	1000	1100	1200	1300	1400	1500	1600	1700	1800	1900	2000	2100	2200
<b>CA*F3743C6*</b>	Wet	0.083	0.093	0.113	0.133	0.143	0.163	0.183	0.213	0.243	0.263	0.293	0.323	0.353	0.383	0.423
	Dry	0.073	0.083	0.103	0.113	0.133	0.153	0.163	0.193	0.213	0.233	0.263	0.293	0.313	0.343	0.373
<b>CA*F3743D6*</b>	Wet	0.074	0.080	0.089	0.107	0.120	0.129	0.138	0.169	0.188	0.209	0.229	0.251	0.273	0.279	0.306
	Dry	0.046	0.056	0.074	0.076	0.086	0.107	0.110	0.126	0.147	0.160	0.176	0.196	0.210	0.230	0.253
	<b>SCFM</b>	<b>1000</b>	<b>1100</b>	<b>1200</b>	<b>1300</b>	<b>1400</b>	<b>1500</b>	<b>1600</b>	<b>1700</b>	<b>1800</b>	<b>1900</b>	<b>2000</b>	<b>2100</b>	<b>2200</b>		
<b>CA*F4860C6*</b>	Wet	0.167	0.191	0.219	0.244	0.266	0.299	0.355	0.370	0.413	0.454	0.498	0.586	0.601		
	Dry	0.160	0.177	0.194	0.206	0.246	0.264	0.264	0.265	0.290	0.309	0.364	0.389	0.562		
<b>CA*F4860D6*</b>	Wet	0.138	0.156	0.177	0.196	0.226	0.247	0.275	0.298	0.327	0.349	0.395	0.460	0.485		
	Dry	0.126	0.138	0.157	0.176	0.187	0.200	0.205	0.210	0.230	0.250	0.280	0.300	0.417		
	<b>SCFM</b>	<b>1000</b>	<b>1100</b>	<b>1200</b>	<b>1300</b>	<b>1400</b>	<b>1500</b>	<b>1600</b>	<b>1700</b>	<b>1800</b>	<b>1900</b>	<b>2000</b>	<b>2100</b>	<b>2200</b>		
<b>CA*F4961C6*</b>	Wet	0.209	0.233	0.255	0.286	0.308	0.341	0.397	0.412	0.455	0.496	0.540	0.628	0.643		
	Dry	0.202	0.219	0.236	0.248	0.288	0.306	0.306	0.307	0.332	0.351	0.406	0.431	0.604		
<b>CA*F4961D6*</b>	Wet	0.140	0.158	0.179	0.198	0.228	0.249	0.277	0.300	0.329	0.351	0.397	0.462	0.487		
	Dry	0.128	0.140	0.159	0.178	0.189	0.202	0.206	0.212	0.232	0.252	0.282	0.302	0.419		

## AIRFLOW DATA FOR CAPT

### AIR QUANTITY (SCFM) VS. PRESSURE DROP (IN. WC)

		600	700	800	900	1000	1100	1200	1300	1400	1500	1600	1700	1800	1900	2000	2100	2200	
<b>CAPT3131B4*</b>	Wet	0.041	0.049	0.061	0.078	0.090	0.113	0.131	0.140	0.162	0.178	0.210							
	Dry	0.021	0.031	0.039	0.048	0.061	0.072	0.079	0.091	0.110	0.122	0.141							
<b>CAPT3131C4*</b>	Wet	0.035	0.036	0.038	0.051	0.059	0.073	0.087	0.094	0.110	0.125	0.145							
	Dry	0.014	0.022	0.028	0.036	0.045	0.054	0.061	0.068	0.081	0.091	0.108							
<b>CAPT3743C4*</b>	Wet	0.083	0.093	0.113	0.133	0.143	0.163	0.183	0.213	0.243	0.263	0.293	0.323	0.353	0.383	0.423			
	Dry	0.073	0.083	0.103	0.113	0.133	0.153	0.163	0.193	0.213	0.233	0.263	0.293	0.313	0.343	0.373			
<b>CAPT3743D4*</b>	Wet	0.074	0.080	0.089	0.107	0.120	0.129	0.138	0.169	0.188	0.209	0.229	0.251	0.273	0.306				
	Dry	0.046	0.056	0.070	0.076	0.086	0.107	0.110	0.126	0.147	0.160	0.176	0.196	0.210	0.230	0.253			
<b>CAPT4961C4*</b>	Wet	0.209	0.233	0.255	0.286	0.308	0.341	0.397	0.412	0.455	0.496	0.540	0.628	0.643					
	Dry	0.202	0.219	0.236	0.248	0.288	0.300	0.306	0.315	0.332	0.351	0.406	0.431	0.604					
<b>CAPT4961D4*</b>	Wet	0.140	0.158	0.179	0.198	0.228	0.249	0.277	0.300	0.329	0.351	0.397	0.462	0.487					
	Dry	0.128	0.140	0.159	0.178	0.189	0.202	0.206	0.212	0.232	0.252	0.282	0.302	0.419					

## AIRFLOW DATA FOR CHPF AND CHPE

### AIR QUANTITY (SCFM) vs. PRESSURE DROP (IN. WC)

	SCFM	600	700	800	900	1000	1100	1200	1300	1400						
CHPF1824A6*	Wet	0.132	0.179	0.222	0.272	0.327	0.381	0.456	0.522	0.605						
	Dry	0.126	0.165	0.206	0.249	0.302	0.354	0.414	0.478	0.563						
	SCFM	600	700	800	900	1000	1100	1200	1300	1400	1500	1600				
CHPF2430B6*	Wet	0.106	0.124	0.152	0.184	0.218	0.258	0.301	0.350	0.406	0.460	0.514				
	Dry	0.101	0.122	0.145	0.174	0.209	0.247	0.288	0.333	0.381	0.428	0.484				
	SCFM	600	700	800	900	1000	1100	1200	1300	1400	1500	1600				
CHPF3636B6*	Wet	0.107	0.131	0.167	0.199	0.239	0.291	0.338	0.389	0.439	0.494	0.552				
	Dry	0.102	0.126	0.152	0.184	0.220	0.259	0.303	0.349	0.401	0.458	0.516				
	SCFM	800	900	1000	1100	1200	1300	1400	1500	1600	1700	1800	1900	2000	2100	2200
CHPF3642C6*	Wet	0.083	0.103	0.126	0.151	0.178	0.208	0.240	0.274	0.310	0.346	0.383	---	---	---	---
	Dry	0.073	0.096	0.120	0.144	0.169	0.196	0.224	0.254	0.286	0.319	0.354	---	---	---	---
CHPE3642C4*	Wet	0.040	0.050	0.060	0.070	0.080	0.080	0.090	0.100	0.110	0.120	0.120	0.130	0.150	0.160	0.180
	Dry	0.030	0.040	0.040	0.050	0.060	0.070	0.080	0.085	0.090	0.100	0.110	0.120	0.140	0.150	0.160
	SCFM	800	900	1000	1100	1200	1300	1400	1500	1600	1700	1800	1900	2000	2100	2200
CHPF3743C6*	Wet	0.133	0.153	0.176	0.201	0.228	0.258	0.290	0.324	0.360	0.396	0.433	---	---	---	---
	Dry	0.123	0.146	0.170	0.194	0.219	0.246	0.274	0.304	0.336	0.369	0.404	---	---	---	---
CHPE3743D4*	Wet	0.101	0.105	0.115	0.125	0.145	0.165	0.195	0.215	0.235	0.265	0.295	0.315	0.355	0.375	0.405
	Dry	0.072	0.095	0.105	0.115	0.135	0.155	0.185	0.205	0.225	0.255	0.275	0.305	0.335	0.365	0.395
	SCFM	900	1000	1100	1200	1300	1400	1500	1600	1700	1800	1900	2000	2100	2200	
CHPF4860D6*	Wet	0.111	0.131	0.151	0.171	0.191	0.211	0.231	0.261	0.291	0.321	0.361	0.391	0.431	0.471	
	Dry	0.101	0.121	0.141	0.161	0.181	0.201	0.221	0.251	0.281	0.311	0.341	0.371	0.411	0.441	

## AIRFLOW DATA FOR CSCF

### AIR QUANTITY (SCFM) vs. PRESSURE DROP (IN. WC)

	SCFM	500	600	700	800	900	1000	1100	1200										
CSCF1824N6D*	Wet	0.104	0.143	0.176	0.212	0.255	0.292	0.321	0.344										
	Dry	0.048	0.067	0.086	0.108	0.132	0.159	0.186	0.206										
	SCFM			700	800	900	1000	1100	1200	1300	1400								
CSCF3036N6D*	Wet	---	---	0.062	0.076	0.092	0.109	0.131	0.156	0.186	0.209								
	Dry	---	---	0.032	0.043	0.055	0.068	0.082	0.099	0.114	0.131								
	SCFM			800	900	1000	1100	1200	1300	1400	1500	1600	1700	1800	1900	2000	2100	2200	
CSCF3642N6D*	Wet	---	---	---	0.045	0.063	0.081	0.099	0.116	0.132	0.148	0.166	0.183	0.202	0.220	0.236	0.259	0.278	0.291
	Dry	---	---	---	0.039	0.051	0.064	0.077	0.092	0.105	0.121	0.138	0.150	0.175	0.191	0.214	0.230	0.251	0.262
	SCFM			800	900	1000	1100	1200	1300	1400	1500	1600	1700	1800	1900	2000	2100	2200	
CSCF4860N6D*	Wet	---	---	---	0.051	0.068	0.085	0.103	0.120	0.137	0.154	0.173	0.192	0.212	0.233	0.255	0.278	0.299	0.319
	Dry	---	---	---	0.043	0.056	0.069	0.084	0.099	0.115	0.132	0.149	0.167	0.185	0.207	0.227	0.249	0.272	.282**

\*\* Maximum SCFM = 2146

## ACCESSORIES

### EXPANSION VALVE KITS FOR NON-TXV, NON-EEV COILS

KIT NUMBER	DESCRIPTION	APPLICATION	REFRIGERANT	TONNAGE: OUTDOOR UNIT
TXV-30 <sup>2</sup>	Non-bleed Valve	AC Only	R-410A	1½- 2½ Ton
TXV-42 <sup>2</sup>	Non-bleed Valve	AC Only	R-410A	3- 3½ Ton
TXV-48 <sup>2</sup>	Non-bleed Valve	AC Only	R-410A	4 Ton
TXV-60 <sup>2</sup>	Non-bleed Valve	AC Only	R-410A	5 Ton
TX2N4A	Non-bleed Valve	AC or HP	R-410A	1½- 2 Ton
TX3N4	Non-bleed Valve	AC or HP	R-410A	2½- 3 Ton
TX5N4	Non-bleed Valve	AC or HP	R-410A	3½- 5 Ton

**Note:** Condensing units and heat pumps with reciprocating compressors require the use of start-assist components when used in conjunction with an indoor coil using a non-bleed thermal expansion valve refrigerant metering device.

### HIGH-TEMP DRAIN PAN KITS FOR CAUF, CAPF AND CAPT

DRAIN PAN KITS	FURNACE SIZE
HTP-A	14" furnaces
HTP-B	17½" furnaces
HTP-C	21" furnaces
HTP-D	24½" furnaces

### DOWNFLOW KIT FOR CAPE

KIT NUMBER	CABINET WIDTH
DFKE-001	21" , 24½"

### DRAIN PAN INSULATION KITS FOR CAPEA, CAPFA, & CAUFA

KIT NUMBER	CABINET WIDTH
DPICX-AB	14"
DPICX-BB	17½"
DPICX-CB	21"
DPICX-DB	24½"

### DRAIN PAN INSULATION KITS FOR CAPE

KIT NUMBER	CABINET WIDTH
(a) DPICX-C (b) DPICX-CA	21"
(a) DPICX-D (b) DPICX-DA	24½"

\* (a) and (b) are compatible.  
(a) being used to depletion (a) by replaced (b).