



DH4SEA COMMERCIAL

COOLING CAPACITY: 36,000 TO 60,000 BTU/H

HEATING CAPACITY: 36,000 TO 60,000 BTU/H

3, 4, & 5-TON, THREE-PHASE
R-32 SPLIT SYSTEM HEAT PUMP



Contents

Nomenclature	2
Product Specifications	3
Expanded Cooling Data.....	4
Expanded Heating Data	10
Performance	11
AHRI Ratings	12
Dimensions	13
Wiring Diagram.....	14
Accessories	15

R32

Standard Features

- High-efficiency Copeland® scroll compressor
- Advanced Copeland® CoreSense™ technology
- Enhanced aluminum fin coil with 5mm diameter copper tubes in 3-ton
- Enhanced aluminum fin coil with 7mm diameter copper tubes in 4.0- to 5.0-ton
- Time-delay technology to ensure quiet reliable defrost
- Factory-installed bi-flow liquid line filter drier
- Factory-installed suction line accumulator
- Factory-installed compressor crank case heater
- Factory-installed high capacity muffler
- High- and low-pressure switches
- Service valves with sweat connections and easy access to gauge ports
- Fully enclosed contactor with lug connection
- Fully charged for 15' of tubing length
- Capacitors with extended life
- AHRI Certified; ETL Listed

Cabinet Features

- Removable grille-style top design compliant with UL 60335-2-40
- Venturi for increased velocity of airflow
- Custom Nickel Gray powder- paint finish with 500- hour salt- spray approval
- Steel louver coil guard with rust-resistant screws
- Wire fan discharge grille
- Steel louver coil guard
- Rust-resistant screws
- Top and side maintenance access
- Single-panel access to controls with space provided for field-installed accessories



* Complete warranty details available from your local dealer or at www.daikincomfort.com.

	DH4SEA 3630*	DH4SEA 4830*	DH4SEA 6030*	DH4SEA 3640*	DH4SEA 4840*	DH4SEA 6040*
COOLING CAPACITIES						
NOMINAL COOLING (BTU/H)	36,000	48,000	60,000	36,000	48,000	60,000
Nominal Heating (BTU/h)	36,000	48,000	60,000	36,000	48,000	60,000
Decibels (dB)	72	74	74	72	74	74
COMPRESSOR						
RLA	10.6	12.2	15.4	4.9	5.8	7.7
LRA	97.5	120.0	156.0	44.3	55.1	69.0
Stage	Single	Single	Single	Single	Single	Single
Type	Scroll	Scroll	Scroll	Scroll	Scroll	Scroll
CONDENSER FAN MOTOR						
Motor Type	PSC	PSC	PSC	PSC	PSC	PSC
Horsepower	1/6	1/4	1/4	1/6	1/4	1/4
FLA	0.97	1.30	1.30	0.60	0.80	0.80
REFRIGERATION SYSTEM						
Refrigerant Line Size ¹						
Liquid Line Size ("O.D.)	3/8"	3/8"	3/8"	3/8"	3/8"	3/8"
Suction Line Size ("O.D.)	7/8"	1 1/8"	1 1/8"	7/8"	1 1/8"	1 1/8"
Refrigerant Connection Size						
Liquid Valve Size ("O.D.)	3/8"	3/8"	3/8"	3/8"	3/8"	3/8"
Suction Valve Size ("O.D.)	7/8"	7/8"	7/8"	7/8"	7/8"	7/8"
Valve Connection Type	Sweat	Sweat	Sweat	Sweat	Sweat	Sweat
Refrigerant Charge	83	174	194	83	174	194
ELECTRICAL DATA						
Voltage-Phase	208/230-3	208/230-3	208/230-3	460-3	460-3	460-3
Minimum Circuit Ampacity ²	14.2	16.5	20.5	6.7	8.0	10.4
Max. Overcurrent Protection ³	20	25	35	10	10	15
Min / Max Volts	197/253	197/253	197/253	437/506	437/506	437/506
Electrical Conduit Size	1/2" or 3/4"	1/2" or 3/4"	1/2" or 3/4"	1/2" or 3/4"	1/2" or 3/4"	1/2" or 3/4"
UNIT WEIGHTS						
EQUIPMENT WEIGHT	198	263	286	199	266	288
SHIPPING WEIGHT	218	283	306	219	286	308

¹ Tested and rated in accordance with ARI Standard

² Wire size should be determined in accordance with National Electrical Codes; extensive wireruns will require larger wire sizes

³ Must use time-delay fuses or HACR-type circuit breakers of the same size as noted.

NOTES

- Always check the S&R plate for electrical data on the unit being installed.
- Installer will need to supply 3/8" to 1 1/8" adapters for suction line connections.
- Unit is charged with refrigerant for 15' of 3/8" liquid line. System charge must be adjusted per Installation Instructions Final Charge Procedure.
- Installation of these units requires the specified TXV Kit to be installed on the indoor coil. THE SPECIFIED TXV IS DETERMINED BY THE OUTDOOR UNIT NOT THE INDOOR COIL.

EXPANDED COOLING DATA — DH4SEA3630A*/3640A*+AMST36CU1300A*

IDB		OUTDOOR AMBIENT TEMPERATURE												ENTERING INDOOR WET BULB TEMPERATURE											
		65				75				85				95				105				115			
		59	63	67	71	59	63	67	71	59	63	67	71	59	63	67	71	59	63	67	71	59	63	67	71
70	MBh	35.6	36.1	37.2	-	35.3	35.8	36.9	-	34.4	34.9	36.0	-	32.8	33.3	34.4	-	30.8	31.3	32.4	-	29.0	29.5	30.6	-
	S/T	0.61	0.53	0.40	-	0.62	0.54	0.41	-	0.64	0.57	0.43	-	0.66	0.59	0.45	-	1.00	0.61	0.47	-	1.00	0.66	0.52	-
	ΔT	19	18	14	-	19	18	14	-	20	18	14	-	19	18	14	-	19	17	14	-	20	18	15	-
	KW	2.02	2.02	2.02	-	2.26	2.26	2.26	-	2.53	2.53	2.52	-	2.82	2.81	2.81	-	3.14	3.14	3.13	-	3.52	3.51	3.51	-
	Amps	7.6	7.6	7.5	-	8.7	8.6	8.6	-	9.9	9.9	9.8	-	11.2	11.2	11.2	-	12.7	12.7	12.6	-	14.4	14.4	14.4	-
1050	MBh	36.1	36.6	37.6	-	35.8	36.3	37.3	-	34.8	35.3	36.4	-	33.2	33.7	34.8	-	31.3	31.8	32.8	-	29.5	30.0	31.1	-
	S/T	0.67	0.59	0.45	-	0.67	0.60	0.46	-	0.70	0.62	0.49	-	0.72	0.64	0.51	-	1.00	0.66	0.53	-	1.00	0.71	0.58	-
	ΔT	18	17	13	-	18	17	13	-	19	17	13	-	18	17	13	-	18	16	13	-	19	17	14	-
	KW	2.03	2.03	2.03	-	2.27	2.27	2.27	-	2.54	2.54	2.53	-	2.83	2.83	2.82	-	3.15	3.15	3.14	-	3.53	3.53	3.52	-
	Amps	7.6	7.6	7.6	-	8.7	8.7	8.7	-	9.9	9.9	9.9	-	11.2	11.2	11.2	-	12.7	12.7	12.7	-	14.5	14.4	14.4	-
1350	MBh	36.7	37.2	38.3	-	36.4	36.9	37.9	-	35.4	35.9	37.0	-	33.8	34.3	35.4	-	31.9	32.4	33.4	-	30.1	30.6	31.7	-
	S/T	0.70	0.63	0.49	-	0.71	0.63	0.50	-	0.73	0.66	0.52	-	1.00	0.68	0.54	-	1.00	0.70	0.56	-	1.00	0.75	0.61	-
	ΔT	17	16	12	-	17	16	12	-	18	16	12	-	17	16	12	-	17	15	12	-	18	16	13	-
	KW	2.04	2.04	2.04	-	2.28	2.28	2.28	-	2.55	2.55	2.54	-	2.84	2.84	2.83	-	3.16	3.16	3.16	-	3.54	3.54	3.53	-
	Amps	7.7	7.7	7.6	-	8.8	8.7	8.7	-	10.0	10.0	10.0	-	11.3	11.3	11.3	-	12.8	12.8	12.7	-	14.5	14.5	14.5	-
75	MBh	35.7	36.2	37.2	38.8	35.3	35.8	36.9	38.5	34.4	34.9	36.0	37.6	32.8	33.3	34.4	36.0	30.9	31.4	32.4	34.0	29.1	29.6	30.6	32.3
	S/T	0.74	0.66	0.53	0.39	0.75	0.67	0.53	0.39	1.00	0.70	0.56	0.42	1.00	0.71	0.58	0.44	1.00	0.74	0.60	0.46	1.00	0.79	0.65	0.51
	ΔT	23	22	18	15	23	22	18	15	24	22	18	15	23	22	18	15	23	21	18	14	24	22	19	16
	KW	2.02	2.02	2.01	2.0	2.26	2.26	2.25	2.3	2.53	2.52	2.52	2.5	2.81	2.81	2.81	2.8	3.14	3.14	3.13	3.1	3.52	3.51	3.51	3.5
	Amps	7.6	7.5	7.5	7.6	8.6	8.6	8.6	8.7	9.9	9.9	9.8	9.9	11.2	11.2	11.2	11.2	12.7	12.7	12.6	12.7	14.4	14.4	14.4	14.5
1050	MBh	36.1	36.6	37.7	39.3	35.8	36.3	37.3	39.0	34.8	35.4	36.4	38.0	33.2	33.8	34.8	36.4	31.3	31.8	32.9	34.5	29.5	30.0	31.1	32.7
	S/T	0.80	0.72	0.58	0.44	0.80	0.73	0.59	0.45	1.00	0.75	0.62	0.47	1.00	0.77	0.63	0.49	1.00	0.79	0.66	0.51	1.00	1.00	0.71	0.57
	ΔT	22	21	17	14	22	21	17	14	23	21	17	14	22	21	17	14	22	20	17	13	23	21	18	15
	KW	2.03	2.03	2.03	2.04	2.27	2.27	2.27	2.28	2.54	2.54	2.53	2.55	2.83	2.82	2.82	2.84	3.15	3.15	3.14	3.16	3.53	3.53	3.52	3.54
	Amps	7.6	7.6	7.6	7.7	8.7	8.7	8.7	8.8	9.9	9.9	9.9	10.0	11.2	11.2	11.2	11.3	12.7	12.7	12.7	12.8	14.4	14.4	14.4	14.5
1350	MBh	36.7	37.2	38.3	39.9	36.4	36.9	38.0	39.6	35.5	36.0	37.0	38.6	33.9	34.4	35.4	37.0	31.9	32.4	33.5	35.1	30.1	30.6	31.7	33.3
	S/T	0.83	0.76	0.62	0.48	0.84	0.76	0.63	0.48	1.00	0.79	0.65	0.51	1.00	0.81	0.67	0.53	1.00	0.83	0.69	0.55	1.00	1.00	0.74	0.60
	ΔT	21	20	16	13	21	20	16	13	22	20	16	13	21	20	16	13	21	19	16	12	22	20	17	14
	KW	2.04	2.04	2.04	2.1	2.28	2.28	2.28	2.3	2.55	2.55	2.54	2.6	2.84	2.84	2.83	2.8	3.16	3.16	3.15	3.2	3.54	3.54	3.53	3.6
	Amps	7.7	7.6	7.6	7.7	8.8	8.7	8.7	8.8	10.0	10.0	9.9	10.0	11.3	11.3	11.3	11.3	12.8	12.8	12.7	12.8	14.5	14.5	14.5	14.6

IDB: Entering Indoor Dry Bulb Temperature
 High and low pressures are measured at the liquid and suction service valves.
 Shaded area is ACCA (TVA) conditions.
 KW=Total system power
 Amps = outdoor unit amps (Comp.+Fan)

EXPANDED COOLING DATA — DH4SEA3630A*/3640A*+AMST36CU1300A* (CONT.)

IDB		OUTDOOR AMBIENT TEMPERATURE																							
		65				75				85				95				105				115			
		59	63	67	71	59	63	67	71	59	63	67	71	59	63	67	71	59	63	67	71	59	63	67	71
		ENTERING INDOOR WET BULB TEMPERATURE																							
1050	MBh	35.8	36.3	37.4	39.0	35.5	36.0	37.1	38.7	34.6	35.1	36.2	37.8	33.0	33.5	34.6	36.2	31.0	31.5	32.6	34.2	29.3	29.8	30.8	32.4
	S/T	0.87	0.79	0.65	0.51	1.00	0.80	0.66	0.52	1.00	0.82	0.69	0.54	1.00	0.84	0.70	0.56	1.00	1.00	0.73	0.58	1.00	1.00	0.78	0.64
	ΔT	27	26	22	19	27	26	22	19	28	26	22	19	27	26	22	19	27	25	22	18	28	26	23	20
	kW	2.02	2.02	2.02	2.0	2.26	2.26	2.25	2.3	2.53	2.53	2.52	2.5	2.82	2.81	2.81	2.8	3.14	3.14	3.13	3.2	3.52	3.51	3.51	3.5
	Amps	7.6	7.6	7.5	7.6	8.7	8.6	8.6	8.7	9.9	9.9	9.8	9.9	11.2	11.2	11.2	11.3	12.7	12.7	12.6	12.7	14.4	14.4	14.4	14.5
80	MBh	36.3	36.8	37.8	39.5	36.0	36.5	37.5	39.2	35.0	35.5	36.6	38.2	33.4	33.9	35.0	36.6	31.5	32.0	33.0	34.7	29.7	30.2	31.3	32.9
	S/T	1.00	0.85	0.71	0.57	1.00	0.85	0.72	0.57	1.00	0.88	0.74	0.60	1.00	0.90	0.76	0.62	1.00	1.00	0.78	0.64	1.00	1.00	0.83	0.69
	ΔT	26	25	21	18	26	25	21	18	27	25	21	18	26	25	21	18	26	24	21	17	27	25	22	19
	kW	2.03	2.03	2.03	2.05	2.27	2.27	2.27	2.28	2.54	2.54	2.53	2.55	2.83	2.83	2.82	2.84	3.15	3.15	3.14	3.16	3.53	3.53	3.52	3.54
	Amps	7.6	7.6	7.6	7.7	8.7	8.7	8.7	8.8	9.9	9.9	9.9	10.0	11.2	11.2	11.2	11.3	12.7	12.7	12.7	12.8	14.5	14.4	14.4	14.5
1350	MBh	36.9	37.4	38.5	40.1	36.6	37.1	38.1	39.8	35.6	36.1	37.2	38.8	34.0	34.5	35.6	37.2	32.1	32.6	33.7	35.3	30.3	30.8	31.9	33.5
	S/T	1.00	0.88	0.75	0.60	1.00	0.89	0.75	0.61	1.00	0.91	0.78	0.63	1.00	1.00	0.80	0.65	1.00	1.00	0.82	0.67	1.00	1.00	0.87	0.73
	ΔT	25	24	20	17	25	24	20	17	26	24	20	17	25	24	20	17	25	23	20	16	26	24	21	18
	kW	2.04	2.04	2.04	2.1	2.28	2.28	2.28	2.3	2.55	2.55	2.54	2.6	2.84	2.84	2.83	2.9	3.16	3.16	3.16	3.2	3.54	3.54	3.53	3.6
	Amps	7.7	7.7	7.6	7.7	8.8	8.7	8.7	8.8	10.0	10.0	10.0	10.0	11.3	11.3	11.3	11.4	12.8	12.8	12.7	12.8	14.5	14.5	14.5	14.6

IDB		OUTDOOR AMBIENT TEMPERATURE																							
		65				75				85				95				105				115			
		59	63	67	71	59	63	67	71	59	63	67	71	59	63	67	71	59	63	67	71	59	63	67	71
		ENTERING INDOOR WET BULB TEMPERATURE																							
1050	MBh	36.4	36.9	38.0	39.6	36.1	36.6	37.7	39.3	35.2	35.7	36.8	38.4	33.6	34.1	35.2	36.8	31.6	32.1	33.2	34.8	29.9	30.4	31.4	33.0
	S/T	1.00	0.89	0.76	0.61	1.00	0.90	0.76	0.62	1.00	1.00	0.79	0.64	1.00	1.00	0.81	0.66	1.00	1.00	0.83	0.68	1.00	1.00	1.00	0.74
	ΔT	31	29	26	22	31	29	26	22	31	29	26	22	31	29	26	22	31	29	25	22	32	30	27	23
	kW	2.03	2.02	2.02	2.0	2.27	2.26	2.26	2.3	2.53	2.53	2.53	2.5	2.82	2.82	2.81	2.8	3.14	3.14	3.14	3.2	3.52	3.52	3.52	3.5
	Amps	7.6	7.6	7.6	7.6	8.7	8.7	8.6	8.7	9.9	9.9	9.9	10.0	11.2	11.2	11.2	11.3	12.7	12.7	12.7	12.7	14.4	14.4	14.4	14.5
85	MBh	36.9	37.4	38.4	40.1	36.6	37.1	38.1	39.8	35.6	36.1	37.2	38.8	34.0	34.5	35.6	37.2	32.1	32.6	33.6	35.3	30.3	30.8	31.9	33.5
	S/T	1.00	0.95	0.81	0.67	1.00	0.95	0.82	0.67	1.00	1.00	0.84	0.70	1.00	1.00	0.86	0.72	1.00	1.00	0.88	0.74	1.00	1.00	1.00	0.79
	ΔT	30	28	25	21	30	28	25	21	30	28	25	21	30	28	25	21	30	28	24	21	31	29	26	22
	kW	2.04	2.04	2.03	2.05	2.28	2.28	2.27	2.29	2.54	2.54	2.54	2.56	2.83	2.83	2.83	2.84	3.15	3.15	3.15	3.17	3.53	3.53	3.53	3.55
	Amps	7.6	7.6	7.6	7.7	8.7	8.7	8.7	8.8	9.9	9.9	9.9	10.0	11.3	11.3	11.2	11.3	12.7	12.7	12.7	12.8	14.5	14.5	14.4	14.5
1350	MBh	37.5	38.0	39.1	40.7	37.2	37.7	38.7	40.4	36.2	36.7	37.8	39.4	34.6	35.1	36.2	37.8	32.7	33.2	34.3	35.9	30.9	31.4	32.5	34.1
	S/T	1.00	0.98	0.85	0.70	1.00	1.00	0.85	0.71	1.00	1.00	0.88	0.73	1.00	1.00	0.90	0.75	1.00	1.00	0.92	0.78	1.00	1.00	1.00	0.83
	ΔT	29	27	24	20	29	27	24	20	29	27	24	20	29	27	24	20	29	27	23	20	30	28	25	21
	kW	2.05	2.05	2.04	2.1	2.29	2.29	2.28	2.3	2.55	2.55	2.55	2.6	2.84	2.84	2.84	2.9	3.17	3.16	3.16	3.2	3.54	3.54	3.54	3.6
	Amps	7.7	7.7	7.7	7.7	8.8	8.8	8.8	8.8	10.0	10.0	10.0	10.1	11.3	11.3	11.3	11.4	12.8	12.8	12.8	12.9	14.5	14.5	14.5	14.6

IDB: Entering Indoor Dry Bulb Temperature
High and low pressures are measured at the liquid and suction service valves.

Shaded area is ACCA (TVA) conditions.

Amps = outdoor unit amps (comp.+fan)
KW= Total system power

EXPANDED COOLING DATA — DH4SEA4830A*/4840A*+AMST48CU1300A*

IDB		OUTDOOR AMBIENT TEMPERATURE												ENTERING INDOOR WET BULB TEMPERATURE											
		65				75				85				95				105				115			
		59	63	67	71	59	63	67	71	59	63	67	71	59	63	67	71	59	63	67	71	59	63	67	71
70	MBh	46.9	47.6	48.9	-	46.5	47.1	48.5	-	45.3	45.9	47.3	-	43.2	43.9	45.2	-	40.7	41.3	42.7	-	38.3	39.0	40.4	-
	S/T	0.67	0.59	0.45	-	0.67	0.60	0.46	-	0.70	0.62	0.49	-	0.72	0.64	0.51	-	1.00	0.66	0.53	-	1.00	0.71	0.58	-
	ΔT	19	17	13	-	19	17	13	-	19	17	14	-	19	17	13	-	18	16	13	-	19	18	14	-
	KW	2.63	2.63	2.62	-	2.95	2.94	2.94	-	3.30	3.29	3.29	-	3.68	3.67	3.67	-	4.10	4.10	4.09	-	4.60	4.60	4.59	-
	Amps	10.0	10.0	9.9	-	11.4	11.4	11.4	-	13.0	13.0	13.0	-	14.8	14.8	14.7	-	16.7	16.7	16.7	-	19.0	19.0	18.9	-
1450	MBh	47.5	48.1	49.5	-	47.1	47.7	49.1	-	45.9	46.5	47.9	-	43.8	44.4	45.8	-	41.2	41.9	43.3	-	38.9	39.6	41.0	-
	S/T	0.70	0.62	0.48	-	0.70	0.63	0.49	-	0.73	0.65	0.52	-	0.75	0.67	0.54	-	1.00	0.69	0.56	-	1.00	0.74	0.61	-
	ΔT	18	16	13	-	18	16	13	-	18	16	13	-	18	16	13	-	18	16	12	-	19	17	13	-
	KW	2.64	2.64	2.64	-	2.96	2.96	2.95	-	3.31	3.31	3.30	-	3.69	3.69	3.68	-	4.11	4.11	4.10	-	4.61	4.61	4.60	-
	Amps	10.0	10.0	10.0	-	11.5	11.5	11.4	-	13.1	13.1	13.0	-	14.8	14.8	14.8	-	16.8	16.7	16.7	-	19.0	19.0	19.0	-
1800	MBh	48.4	49.1	50.5	-	48.0	48.7	50.1	-	46.8	47.5	48.9	-	44.7	45.4	46.8	-	42.2	42.9	44.2	-	39.9	40.5	41.9	-
	S/T	0.71	0.64	0.50	-	0.72	0.64	0.51	-	0.74	0.67	0.53	-	1.00	0.69	0.55	-	1.00	0.71	0.57	-	1.00	0.76	0.62	-
	ΔT	17	15	12	-	17	15	12	-	17	15	12	-	17	15	12	-	17	15	11	-	18	16	13	-
	KW	2.66	2.65	2.65	-	2.97	2.97	2.96	-	3.32	3.32	3.31	-	3.70	3.70	3.69	-	4.13	4.12	4.12	-	4.62	4.62	4.61	-
	Amps	10.1	10.1	10.1	-	11.5	11.5	11.5	-	13.1	13.1	13.1	-	14.9	14.9	14.8	-	16.8	16.8	16.8	-	19.1	19.1	19.1	-
75	MBh	46.9	47.6	49.0	51.1	46.5	47.2	48.5	50.7	45.3	46.0	47.3	49.5	43.2	43.9	45.3	47.4	40.7	41.3	42.7	44.8	38.4	39.0	40.4	42.5
	S/T	0.80	0.72	0.58	0.44	0.80	0.73	0.59	0.45	1.00	0.75	0.62	0.47	1.00	0.77	0.63	0.49	1.00	0.79	0.66	0.51	1.00	0.84	0.71	0.57
	ΔT	23	21	17	14	23	21	17	14	23	21	18	14	23	21	17	14	22	20	17	14	23	22	18	15
	KW	2.63	2.63	2.62	2.6	2.94	2.94	2.94	3.0	3.30	3.29	3.29	3.3	3.67	3.67	3.67	3.7	4.10	4.10	4.09	4.1	4.60	4.59	4.59	4.6
	Amps	10.0	10.0	9.9	10.0	11.4	11.4	11.4	11.5	13.0	13.0	13.0	13.1	14.8	14.7	14.7	14.8	16.7	16.7	16.7	16.8	19.0	19.0	18.9	19.0
1450	MBh	47.5	48.2	49.6	51.7	47.1	47.8	49.1	51.3	45.9	46.6	47.9	50.0	43.8	44.5	45.9	48.0	41.3	41.9	43.3	45.4	39.0	39.6	41.0	43.1
	S/T	0.83	0.75	0.61	0.47	0.83	0.76	0.62	0.48	1.00	0.78	0.65	0.50	1.00	0.80	0.66	0.52	1.00	0.82	0.69	0.54	1.00	1.00	0.74	0.60
	ΔT	22	20	17	13	22	20	17	13	22	20	17	13	22	20	17	13	22	20	16	13	23	21	17	14
	KW	2.64	2.64	2.63	2.66	2.96	2.95	2.95	2.97	3.31	3.30	3.30	3.32	3.69	3.68	3.68	3.70	4.11	4.11	4.10	4.13	4.61	4.60	4.60	4.62
	Amps	10.0	10.0	10.0	10.1	11.5	11.5	11.4	11.5	13.1	13.1	13.0	13.1	14.8	14.8	14.8	14.9	16.7	16.7	16.7	16.8	19.0	19.0	19.0	19.1
1800	MBh	48.5	49.1	50.5	52.6	48.1	48.7	50.1	52.2	46.8	47.5	48.9	51.0	44.8	45.4	46.8	48.9	42.2	42.9	44.3	46.4	39.9	40.6	41.9	44.1
	S/T	0.84	0.76	0.63	0.49	0.85	0.77	0.64	0.49	1.00	0.80	0.66	0.52	1.00	0.82	0.68	0.54	1.00	0.84	0.70	0.56	1.00	1.00	0.75	0.61
	ΔT	21	19	16	12	21	19	16	12	21	19	16	12	21	19	16	12	21	19	15	12	22	20	17	13
	KW	2.66	2.65	2.65	2.7	2.97	2.97	2.96	3.0	3.32	3.32	3.31	3.3	3.70	3.70	3.69	3.7	4.12	4.12	4.12	4.1	4.62	4.62	4.61	4.6
	Amps	10.1	10.1	10.1	10.2	11.5	11.5	11.5	11.6	13.1	13.1	13.1	13.2	14.9	14.9	14.8	14.9	16.8	16.8	16.8	16.9	19.1	19.1	19.0	19.2

IDB: Entering Indoor Dry Bulb Temperature
 High and low pressures are measured at the liquid and suction service valves.
 Shaded area is ACCA (TVA) conditions.
 Amps = outdoor unit amps (Comp.+Fan)
 KW=Total system power

EXPANDED COOLING DATA — DH4SEA4830A*/4840A*+AMST48CU1300A* (CONT.)

IDB		OUTDOOR AMBIENT TEMPERATURE																											
		65				75				85				95				105				115							
		59	63	67	71	59	63	67	71	59	63	67	71	59	63	67	71	59	63	67	71	59	63	67	71				
		ENTERING INDOOR WET BULB TEMPERATURE																											
AIRFLOW		59	63	67	71	59	63	67	71	59	63	67	71	59	63	67	71	59	63	67	71	59	63	67	71	59	63	67	71
1450	MBh	47.2	47.8	49.2	51.3	46.8	47.4	48.8	50.9	45.5	46.2	47.6	49.7	43.5	44.1	45.5	47.6	40.9	41.6	43.0	45.1	38.6	39.3	40.6	42.8				
	S/T	0.92	0.85	0.71	0.57	1.00	0.85	0.72	0.57	1.00	0.88	0.74	0.60	1.00	0.90	0.76	0.62	1.00	1.00	0.78	0.64	1.00	1.00	0.83	0.69				
	ΔT	27	25	21	18	27	25	21	18	27	25	22	18	27	25	21	18	26	25	21	18	28	26	22	19				
	kW	2.63	2.63	2.62	2.6	2.95	2.94	2.94	3.0	3.30	3.29	3.29	3.3	3.68	3.67	3.67	3.7	4.10	4.10	4.09	4.1	4.60	4.60	4.59	4.6				
	Amps	10.0	10.0	9.9	10.1	11.4	11.4	11.4	11.5	13.0	13.0	13.0	13.1	14.8	14.7	14.7	14.8	16.7	16.7	16.7	16.8	19.0	19.0	18.9	19.1				
80	MBh	47.8	48.4	49.8	51.9	47.3	48.0	49.4	51.5	46.1	46.8	48.2	50.3	44.1	44.7	46.1	48.2	41.5	42.2	43.6	45.7	39.2	39.8	41.2	43.3				
	S/T	1.00	0.87	0.74	0.60	1.00	0.88	0.75	0.60	1.00	0.91	0.77	0.63	1.00	0.93	0.79	0.65	1.00	1.00	0.81	0.67	1.00	1.00	0.86	0.72				
	ΔT	26	24	21	17	26	24	21	17	26	24	21	17	26	24	21	17	26	24	20	17	27	25	21	18				
	kW	2.64	2.64	2.64	2.66	2.96	2.96	2.95	2.97	3.31	3.31	3.30	3.32	3.69	3.69	3.68	3.70	4.11	4.11	4.10	4.13	4.61	4.61	4.60	4.63				
	Amps	10.0	10.0	10.0	10.1	11.5	11.5	11.4	11.5	13.1	13.1	13.0	13.2	14.8	14.8	14.8	14.9	16.8	16.7	16.7	16.8	19.0	19.0	19.0	19.1				
1800	MBh	48.7	49.4	50.7	52.9	48.3	48.9	50.3	52.4	47.1	47.7	49.1	51.2	45.0	45.7	47.0	49.2	42.5	43.1	44.5	46.6	40.1	40.8	42.2	44.3				
	S/T	1.00	0.89	0.75	0.61	1.00	0.90	0.76	0.62	1.00	0.92	0.79	0.64	1.00	1.00	0.81	0.66	1.00	1.00	0.83	0.68	1.00	1.00	0.88	0.74				
	ΔT	25	23	20	16	25	23	20	16	25	23	20	16	25	23	20	16	25	23	19	16	26	24	21	17				
	kW	2.66	2.65	2.65	2.7	2.97	2.97	2.96	3.0	3.32	3.32	3.31	3.3	3.70	3.70	3.69	3.7	4.13	4.12	4.12	4.1	4.62	4.62	4.61	4.6				
	Amps	10.1	10.1	10.1	10.2	11.5	11.5	11.5	11.6	13.1	13.1	13.1	13.2	14.9	14.9	14.8	14.9	16.8	16.8	16.8	16.9	19.1	19.1	19.1	19.2				
85	MBh	47.9	48.6	50.0	52.1	47.5	48.2	49.6	51.7	46.3	47.0	48.4	50.5	44.2	44.9	46.3	48.4	41.7	42.4	43.7	45.9	39.4	40.0	41.4	43.5				
	S/T	1.00	0.95	0.81	0.67	1.00	0.95	0.82	0.67	1.00	1.00	0.84	0.70	1.00	1.00	0.86	0.72	1.00	1.00	0.88	0.74	1.00	1.00	1.00	0.79				
	ΔT	30	28	25	21	30	28	25	21	30	29	25	22	30	28	25	21	30	28	25	21	31	29	26	22				
	kW	2.64	2.64	2.63	2.7	2.95	2.95	2.94	3.0	3.30	3.30	3.29	3.3	3.68	3.68	3.67	3.7	4.11	4.10	4.10	4.1	4.60	4.60	4.60	4.6				
	Amps	10.0	10.0	10.0	10.1	11.4	11.4	11.4	11.5	13.1	13.0	13.0	13.1	14.8	14.8	14.8	14.9	16.7	16.7	16.7	16.8	19.0	19.0	19.0	19.1				
1600	MBh	48.5	49.2	50.6	52.7	48.1	48.8	50.2	52.3	46.9	47.6	49.0	51.1	44.8	45.5	46.9	49.0	42.3	42.9	44.3	46.4	40.0	40.6	42.0	44.1				
	S/T	1.00	0.98	0.84	0.70	1.00	0.98	0.85	0.70	1.00	1.00	0.87	0.73	1.00	1.00	0.89	0.75	1.00	1.00	0.91	0.77	1.00	1.00	1.00	0.82				
	ΔT	29	28	24	21	29	28	24	21	30	28	24	21	29	28	24	21	29	27	24	20	30	28	25	22				
	kW	2.65	2.65	2.64	2.67	2.96	2.96	2.96	2.98	3.31	3.31	3.31	3.33	3.69	3.69	3.69	3.71	4.12	4.12	4.11	4.13	4.61	4.61	4.61	4.63				
	Amps	10.1	10.1	10.0	10.1	11.5	11.5	11.5	11.6	13.1	13.1	13.1	13.2	14.8	14.8	14.8	14.9	16.8	16.8	16.7	16.9	19.1	19.0	19.0	19.1				
1800	MBh	49.5	50.1	51.5	53.6	49.1	49.7	51.1	53.2	47.9	48.5	49.9	52.0	45.8	46.4	47.8	49.9	43.2	43.9	45.3	47.4	40.9	41.6	43.0	45.1				
	S/T	1.00	0.99	0.86	0.71	1.00	1.00	0.86	0.72	1.00	1.00	0.89	0.74	1.00	1.00	0.91	0.76	1.00	1.00	0.93	0.79	1.00	1.00	1.00	0.84				
	ΔT	29	27	23	20	29	27	23	20	29	27	24	20	28	27	23	20	28	26	23	19	29	28	24	21				
	kW	2.66	2.66	2.66	2.7	2.98	2.97	2.97	3.0	3.33	3.33	3.32	3.3	3.71	3.70	3.70	3.7	4.13	4.13	4.12	4.1	4.63	4.63	4.62	4.6				
	Amps	10.1	10.1	10.1	10.2	11.6	11.5	11.5	11.6	13.2	13.2	13.1	13.2	14.9	14.9	14.9	15.0	16.8	16.8	16.8	16.9	19.1	19.1	19.1	19.2				

IDB: Entering Indoor Dry Bulb Temperature
 High and low pressures are measured at the liquid and suction service valves.
 Shaded area is ACCA (TVA) conditions.
 kW= Total system power
 Amps = outdoor unit amps (comp.+fan)

EXPANDED COOLING DATA — DH4SEA6030A*/6040A*+AMST60DU1300A*

IDB		OUTDOOR AMBIENT TEMPERATURE												ENTERING INDOOR WET BULB TEMPERATURE											
		65				75				85				95				105				115			
		59	63	67	71	59	63	67	71	59	63	67	71	59	63	67	71	59	63	67	71	59	63	67	71
70	MBh	58.2	59.0	60.8	-	57.7	58.5	60.3	-	56.2	57.0	58.8	-	53.6	54.5	56.2	-	50.5	51.3	53.0	-	47.6	48.4	50.1	-
	S/T	0.65	0.57	0.44	-	0.66	0.58	0.45	-	0.68	0.61	0.47	-	0.70	0.62	0.49	-	1.00	0.65	0.51	-	1.00	0.70	0.56	-
	ΔT	19	17	14	-	19	17	14	-	19	17	14	-	19	17	14	-	19	17	13	-	20	18	15	-
	KW	3.21	3.21	3.20	-	3.62	3.62	3.61	-	4.07	4.07	4.06	-	4.57	4.56	4.56	-	5.12	5.12	5.11	-	5.76	5.76	5.75	-
	Amps	12.6	12.6	12.6	-	14.5	14.5	14.5	-	16.6	16.6	16.5	-	18.8	18.8	18.8	-	21.4	21.3	21.3	-	24.3	24.3	24.3	-
1800	MBh	59.0	59.8	61.6	-	58.5	59.3	61.0	-	57.0	57.8	59.5	-	54.4	55.2	57.0	-	51.3	52.1	53.8	-	48.4	49.2	50.9	-
	S/T	0.68	0.61	0.47	-	0.69	0.61	0.48	-	0.71	0.64	0.50	-	0.73	0.65	0.52	-	1.00	0.68	0.54	-	1.00	0.73	0.59	-
	ΔT	18	16	13	-	18	16	13	-	18	17	13	-	18	16	13	-	18	16	13	-	19	17	14	-
	KW	3.23	3.22	3.22	-	3.63	3.63	3.62	-	4.09	4.09	4.08	-	4.58	4.58	4.57	-	5.13	5.13	5.12	-	5.78	5.78	5.77	-
	Amps	12.7	12.7	12.7	-	14.6	14.6	14.5	-	16.7	16.6	16.6	-	18.9	18.9	18.9	-	21.4	21.4	21.4	-	24.4	24.4	24.3	-
2250	MBh	60.2	61.0	62.8	-	59.7	60.5	62.2	-	58.2	59.0	60.7	-	55.6	56.4	58.2	-	52.5	53.3	55.0	-	49.6	50.4	52.1	-
	S/T	0.69	0.62	0.49	-	0.70	0.62	0.49	-	0.72	0.65	0.52	-	1.00	0.67	0.54	-	1.00	0.69	0.56	-	1.00	0.74	0.61	-
	ΔT	17	15	12	-	17	15	12	-	17	16	12	-	17	15	12	-	17	15	12	-	18	16	13	-
	KW	3.24	3.24	3.23	-	3.65	3.65	3.64	-	4.11	4.10	4.10	-	4.60	4.60	4.59	-	5.15	5.15	5.14	-	5.80	5.79	5.79	-
	Amps	12.8	12.8	12.7	-	14.7	14.6	14.6	-	16.7	16.7	16.7	-	19.0	19.0	18.9	-	21.5	21.5	21.5	-	24.5	24.5	24.4	-
1800	MBh	58.3	59.1	60.8	63.4	57.8	58.6	60.3	62.9	56.3	57.1	58.8	61.4	53.7	54.5	56.2	58.8	50.5	51.3	53.0	55.7	47.6	48.4	50.2	52.8
	S/T	0.77	0.70	0.57	0.43	0.78	0.71	0.57	0.44	1.00	0.73	0.60	0.46	1.00	0.75	0.62	0.48	1.00	0.77	0.64	0.50	1.00	0.82	0.69	0.55
	ΔT	23	21	18	14	23	21	18	14	23	21	18	14	23	21	18	14	23	21	17	14	24	22	19	15
	KW	3.21	3.20	3.20	3.2	3.62	3.61	3.61	3.6	4.07	4.07	4.06	4.1	4.56	4.56	4.55	4.6	5.12	5.11	5.11	5.1	5.76	5.76	5.75	5.8
	Amps	12.6	12.6	12.6	12.7	14.5	14.5	14.4	14.6	16.6	16.6	16.5	16.7	18.8	18.8	18.8	18.9	21.3	21.3	21.3	21.4	24.3	24.3	24.3	24.4
2000	MBh	59.1	59.9	61.6	64.2	58.6	59.4	61.1	63.7	57.1	57.9	59.6	62.2	54.5	55.3	57.0	59.6	51.3	52.1	53.8	56.5	48.4	49.2	51.0	53.6
	S/T	0.81	0.73	0.60	0.46	0.81	0.74	0.61	0.47	1.00	0.76	0.63	0.49	1.00	0.78	0.65	0.51	1.00	0.80	0.67	0.53	1.00	1.00	0.72	0.58
	ΔT	22	20	17	13	22	20	17	13	23	21	17	14	22	20	17	13	22	20	17	13	23	21	18	14
	KW	3.22	3.22	3.21	3.24	3.63	3.63	3.62	3.65	4.09	4.08	4.08	4.11	4.58	4.57	4.57	4.60	5.13	5.13	5.12	5.15	5.78	5.77	5.77	5.80
	Amps	12.7	12.7	12.6	12.8	14.6	14.5	14.5	14.7	16.6	16.6	16.6	16.7	18.9	18.9	18.9	19.0	21.4	21.4	21.4	21.5	24.4	24.4	24.3	24.5
2250	MBh	60.3	61.1	62.8	65.4	59.8	60.6	62.3	64.9	58.3	59.1	60.8	63.4	55.7	56.5	58.2	60.8	52.5	53.3	55.0	57.7	49.6	50.4	52.2	54.8
	S/T	0.82	0.74	0.61	0.47	0.82	0.75	0.62	0.48	1.00	0.78	0.64	0.50	1.00	0.79	0.66	0.52	1.00	0.82	0.68	0.54	1.00	1.00	0.73	0.59
	ΔT	21	19	16	12	21	19	16	12	22	20	16	13	21	19	16	12	21	19	16	12	22	20	17	13
	KW	3.24	3.24	3.23	3.3	3.65	3.65	3.64	3.7	4.11	4.10	4.10	4.1	4.60	4.60	4.59	4.6	5.15	5.15	5.14	5.2	5.80	5.79	5.79	5.8
	Amps	12.8	12.8	12.7	12.9	14.6	14.6	14.6	14.7	16.7	16.7	16.7	16.8	19.0	19.0	18.9	19.1	21.5	21.5	21.5	21.6	24.5	24.4	24.4	24.6

IDB: Entering Indoor Dry Bulb Temperature
 High and low pressures are measured at the liquid and suction service valves.
 Shaded area is ACCA (TVA) conditions.
 Amps = outdoor unit amps (Comp.+Fan)
 KW=Total system power

EXPANDED COOLING DATA — DH4SEA6030A*/6040A*+AMST60DU1300A* (CONT.)

IDB		OUTDOOR AMBIENT TEMPERATURE																											
		65				75				85				95				105				115							
		59	63	67	71	59	63	67	71	59	63	67	71	59	63	67	71	59	63	67	71	59	63	67	71				
		ENTERING INDOOR WET BULB TEMPERATURE																											
AIRFLOW		59	63	67	71	59	63	67	71	59	63	67	71	59	63	67	71	59	63	67	71	59	63	67	71	59	63	67	71
1800	MBh	58.6	59.4	61.1	63.7	58.1	58.9	60.6	63.2	56.6	57.4	59.1	61.7	54.0	54.8	56.5	59.1	50.8	51.6	53.3	56.0	47.9	48.7	50.5	53.1				
	S/T	0.90	0.82	0.69	0.55	1.00	0.83	0.70	0.56	1.00	0.85	0.72	0.58	1.00	0.87	0.74	0.60	1.00	1.00	0.76	0.62	1.00	1.00	0.81	0.67				
	ΔT	27	25	22	18	27	25	22	18	27	26	22	19	27	25	22	18	27	25	22	18	28	26	23	19				
	kW	3.21	3.21	3.20	3.2	3.62	3.62	3.61	3.6	4.07	4.07	4.06	4.1	4.57	4.56	4.56	4.6	5.12	5.11	5.11	5.1	5.76	5.76	5.75	5.8				
	Amps	12.6	12.6	12.6	12.7	14.5	14.5	14.4	14.6	16.6	16.6	16.5	16.7	18.8	18.8	18.8	18.9	21.4	21.3	21.3	21.5	24.3	24.3	24.3	24.4				
2000	MBh	59.4	60.2	61.9	64.5	58.9	59.7	61.4	64.0	57.4	58.2	59.9	62.5	54.8	55.6	57.3	59.9	51.6	52.4	54.1	56.8	48.7	49.5	51.3	53.9				
	S/T	1.00	0.85	0.72	0.58	1.00	0.86	0.73	0.59	1.00	0.88	0.75	0.61	1.00	0.90	0.77	0.63	1.00	1.00	0.79	0.65	1.00	1.00	0.84	0.70				
	ΔT	26	25	21	17	26	25	21	17	27	25	21	18	26	24	21	17	26	24	21	17	27	25	22	18				
	kW	3.23	3.22	3.22	3.25	3.63	3.63	3.62	3.66	4.09	4.09	4.08	4.11	4.58	4.58	4.57	4.60	5.13	5.13	5.12	5.15	5.78	5.78	5.77	5.80				
	Amps	12.7	12.7	12.7	12.8	14.6	14.6	14.5	14.7	16.7	16.6	16.6	16.8	18.9	18.9	18.9	19.0	21.4	21.4	21.4	21.5	24.4	24.4	24.3	24.5				
2250	MBh	60.6	61.4	63.1	65.7	60.1	60.9	62.6	65.2	58.5	59.4	61.1	63.7	56.0	56.8	58.5	61.1	52.8	53.6	55.3	58.0	49.9	50.7	52.5	55.1				
	S/T	1.00	0.87	0.73	0.60	1.00	0.87	0.74	0.60	1.00	0.90	0.77	0.63	1.00	1.00	0.78	0.64	1.00	1.00	0.81	0.67	1.00	1.00	0.86	0.72				
	ΔT	25	24	20	17	25	24	20	16	26	24	20	17	25	24	20	16	25	23	20	16	26	24	21	17				
	kW	3.24	3.24	3.23	3.3	3.65	3.65	3.64	3.7	4.11	4.10	4.10	4.1	4.60	4.60	4.59	4.6	5.15	5.15	5.14	5.2	5.80	5.79	5.79	5.8				
	Amps	12.8	12.8	12.7	12.9	14.6	14.6	14.6	14.7	16.7	16.7	16.7	16.8	19.0	19.0	18.9	19.1	21.5	21.5	21.5	21.6	24.5	24.5	24.4	24.6				
1800	MBh	59.5	60.3	62.1	64.7	59.0	59.8	61.6	64.2	57.5	58.3	60.1	62.7	54.9	55.8	57.5	60.1	51.8	52.6	54.3	56.9	48.9	49.7	51.4	54.1				
	S/T	1.00	0.92	0.79	0.65	1.00	0.93	0.80	0.66	1.00	1.00	0.82	0.68	1.00	1.00	0.84	0.70	1.00	1.00	0.86	0.72	1.00	1.00	1.00	0.77				
	ΔT	31	29	26	22	31	29	26	22	31	29	26	22	31	29	26	22	31	29	25	22	32	30	26	23				
	kW	3.22	3.21	3.21	3.2	3.63	3.62	3.62	3.6	4.08	4.08	4.07	4.1	4.57	4.57	4.56	4.6	5.13	5.12	5.12	5.1	5.77	5.77	5.76	5.8				
	Amps	12.7	12.6	12.6	12.8	14.5	14.5	14.5	14.6	16.6	16.6	16.6	16.7	18.9	18.9	18.8	19.0	21.4	21.4	21.3	21.5	24.4	24.3	24.3	24.4				
2000	MBh	60.3	61.1	62.9	65.5	59.8	60.6	62.3	65.0	58.3	59.1	60.8	63.5	55.7	56.5	58.3	60.9	52.6	53.4	55.1	57.7	49.7	50.5	52.2	54.9				
	S/T	1.00	0.95	0.82	0.68	1.00	0.96	0.83	0.69	1.00	1.00	0.85	0.71	1.00	1.00	0.87	0.73	1.00	1.00	0.89	0.75	1.00	1.00	1.00	0.80				
	ΔT	30	28	25	21	30	28	25	21	30	28	25	21	30	28	25	21	30	28	24	21	31	29	26	22				
	kW	3.23	3.23	3.22	3.25	3.64	3.64	3.63	3.66	4.10	4.09	4.09	4.12	4.59	4.59	4.58	4.61	5.14	5.14	5.13	5.16	5.79	5.78	5.78	5.81				
	Amps	12.7	12.7	12.7	12.8	14.6	14.6	14.6	14.7	16.7	16.7	16.6	16.8	18.9	18.9	18.9	19.0	21.5	21.5	21.4	21.6	24.4	24.4	24.4	24.5				
2250	MBh	61.5	62.3	64.1	66.7	61.0	61.8	63.5	66.2	59.5	60.3	62.0	64.7	56.9	57.7	59.5	62.1	53.8	54.6	56.3	58.9	50.9	51.7	53.4	56.1				
	S/T	1.00	0.97	0.83	0.69	1.00	1.00	0.84	0.70	1.00	1.00	0.86	0.72	1.00	1.00	0.88	0.74	1.00	1.00	0.90	0.77	1.00	1.00	1.00	0.82				
	ΔT	29	27	24	20	29	27	24	20	29	27	24	20	29	27	24	20	29	27	23	20	30	28	25	21				
	kW	3.25	3.25	3.24	3.3	3.66	3.66	3.65	3.7	4.12	4.11	4.10	4.1	4.61	4.61	4.60	4.6	5.16	5.16	5.15	5.2	5.81	5.80	5.80	5.8				
	Amps	12.8	12.8	12.8	12.9	14.7	14.7	14.6	14.8	16.8	16.8	16.7	16.9	19.0	19.0	19.0	19.1	21.5	21.5	21.5	21.6	24.5	24.5	24.5	24.6				

IDB: Entering Indoor Dry Bulb Temperature
 High and low pressures are measured at the liquid and suction service valves.
 Shaded area is ACCA (TVA) conditions.
 kW= Total system power
 Amps = outdoor unit amps (comp.+fan)

EXPANDED HEATING DATA

DH4SEA3630A*/3640A*+AMST36CU1300A*

	OUTDOOR AMBIENT TEMPERATURE																
	65	60	55	50	47	45	40	35	30	25	20	17	15	10	5	0	-5
MBh	43.76	41.15	38.57	36.04	34.40	33.21	30.27	27.46	25.15	23.47	22.25	21.60	20.75	18.61	16.48	14.35	12.21
T/R	32.74	31.08	29.42	27.76	26.77	25.88	23.55	21.37	19.57	18.26	17.32	16.81	16.14	14.48	12.82	11.16	9.50
KW	2.78	2.74	2.70	2.66	2.64	2.62	2.58	2.54	2.50	2.46	2.42	2.40	2.38	2.34	2.30	2.26	2.22
AMPS	10.2	10.0	9.9	9.7	9.6	9.5	9.3	9.2	9.0	8.8	8.6	8.5	8.5	8.3	8.1	7.9	7.8
COP	4.61	4.39	4.18	3.97	3.82	3.71	3.43	3.17	2.95	2.79	2.69	2.64	2.55	2.33	2.10	1.86	1.61

DH4SEA4830A*/4840A*+AMST48CU1300A*

	OUTDOOR AMBIENT TEMPERATURE																
	65	60	55	50	47	45	40	35	30	25	20	17	15	10	5	0	-5
MBh	59.20	55.50	51.87	48.30	46.00	44.34	40.09	36.12	32.88	30.49	28.74	27.80	26.59	23.55	20.52	17.49	14.45
T/R	29.28	27.72	26.16	24.60	23.66	22.81	20.62	18.58	16.91	15.68	14.78	14.30	13.68	12.12	10.56	8.99	7.43
KW	4.09	3.89	3.69	3.49	3.37	3.29	3.09	2.89	2.70	2.50	2.30	2.18	2.10	1.90	1.70	1.50	1.30
AMPS	14.9	14.0	13.2	12.3	11.8	11.5	10.6	9.7	8.9	8.0	7.1	6.6	6.3	5.4	4.5	3.7	2.8
COP	4.25	4.19	4.12	4.06	4.00	3.95	3.80	3.66	3.58	3.58	3.67	3.74	3.71	3.63	3.53	3.41	3.25

DH4SEA6030A*/6040A*+AMST60DU1300A*

	OUTDOOR AMBIENT TEMPERATURE																
	65	60	55	50	47	45	40	35	30	25	20	17	15	10	5	0	-5
MBh	73.01	68.53	64.12	59.79	57.00	54.98	49.87	45.06	41.13	38.24	36.13	35.00	33.53	29.87	26.20	22.53	18.87
T/R	36.11	34.23	32.34	30.45	29.32	28.30	25.66	23.18	21.16	19.67	18.59	18.00	17.25	15.36	13.48	11.59	9.70
KW	4.42	4.34	4.26	4.18	4.14	4.10	4.03	3.95	3.87	3.79	3.71	3.66	3.63	3.55	3.47	3.40	3.32
AMPS	16.4	16.0	15.7	15.3	15.1	15.0	14.6	14.3	14.0	13.6	13.3	13.1	12.9	12.6	12.3	11.9	11.6
COP	4.84	4.63	4.41	4.19	4.04	3.93	3.63	3.35	3.12	2.96	2.85	2.80	2.71	2.46	2.21	1.94	1.67

Calculations are based on nominal CFM and 70 °F indoor dry bulb.

Amps = Outdoor unit amps (comp.+fan)

Note: Shaded area is AHRI Rating Conditions at 47°F outdoor ambient temperature

kW = Total system power

DH4SEA3630A*/3640A*+AMST36CU1300A*

Conditions: 80 °F IBD, 67 °F IWB @ 1190 CFM				
Outdoor Tem. ° F.	Total BTU/h	Sensible BTU/h	Latent BTU/h	Total Watts
75	37,530	26,860	10,670	2,270
80	37,065	26,985	10,080	2,400
85	36,600	27,110	9,490	2,530
90	35,800	26,860	8,940	2,675
95	35,000	26,610	8,390	2,820
100	34,020	26,230	7,790	2,980
105	33,040	25,850	7,190	3,140
110	32,150	25,960	6,190	3,330
115	31,260	26,070	5,190	3,520
TVA Conditions @ 95° OD DB, 75° ID DB 63° ID WB				
95°	33,750	26,000	7,750	2,820

DH4SEA4830A*/4840A*+AMST48CU1300A*

Conditions: 80 °F IBD, 67 °F IWB @ 1600 CFM				
Outdoor Tem. ° F.	Total BTU/h	Sensible BTU/h	Latent BTU/h	Total Watts
75	49,380	36,810	12,570	2,950
80	48,775	36,965	11,810	3,125
85	48,170	37,120	11,050	3,300
90	47,130	36,770	10,360	3,490
95	46,090	36,420	9,670	3,680
100	44,820	35,895	8,925	3,890
105	43,550	35,370	8,180	4,100
110	42,390	35,490	6,900	4,350
115	41,230	35,610	5,620	4,600
TVA Conditions @ 95° OD DB, 75° ID DB 63° ID WB				
95°	44,470	35,590	8,890	3,680

DH4SEA6030A*/6040A*+AMST60DU1300A*

Conditions: 80 °F IBD, 67 °F IWB @ 2000 CFM				
Outdoor Tem. ° F.	Total BTU/h	Sensible BTU/h	Latent BTU/h	Total Watts
75	61,380	44,650	16,730	3,620
80	60,630	44,835	15,795	3,850
85	59,880	45,020	14,860	4,080
90	58,590	44,590	14,000	4,325
95	57,300	44,160	13,140	4,570
100	55,720	43,530	12,190	4,845
105	54,140	42,900	11,240	5,120
110	52,700	43,040	9,660	5,445
115	51,260	43,180	8,080	5,770
TVA Conditions @ 95° OD DB, 75° ID DB 63° ID WB				
95°	55,280	43,160	12,130	4,580

***ALL AHRI SYSTEM RATINGS ARE ACCESSIBLE IN THE UNITARY MATCHUP TOOL VIA
DAIKIN CITY OR IN THE DAIKIN SYSTEM CONFIGURATOR TOOL VIA PARTNERLINK.***

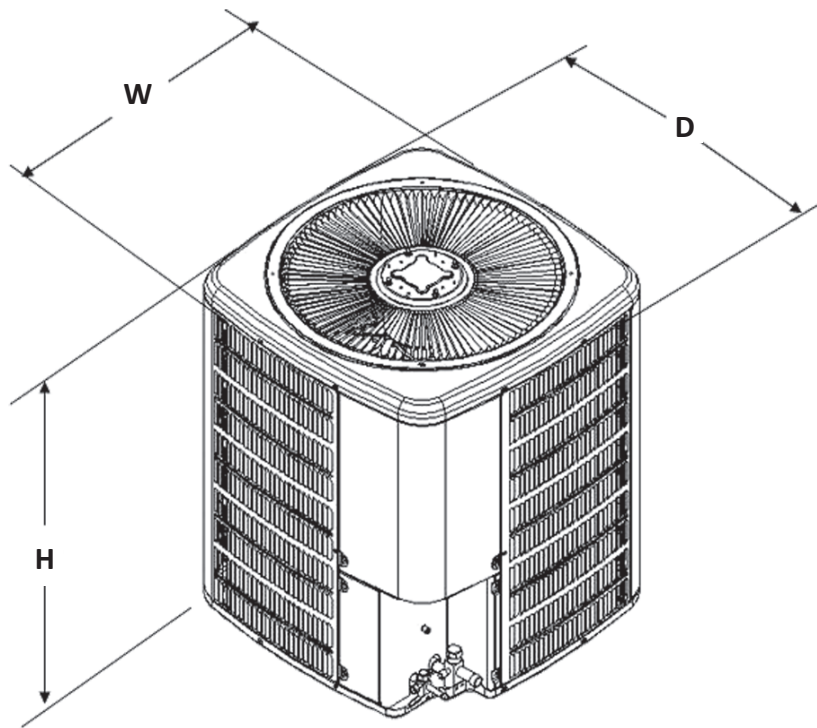

MODEL	DIMENSIONS		
	W"	D"	H"
DH4SEA3630A*	35½	35½	35¾
DH4SEA4830A*	35½	35½	36½
DH4SEA6030A*	35½	35½	41¼
DH4SEA3640A*	35½	35½	35¾
DH4SEA4840A*	35½	35½	36½
DH4SEA6040A*	35½	35½	41¼

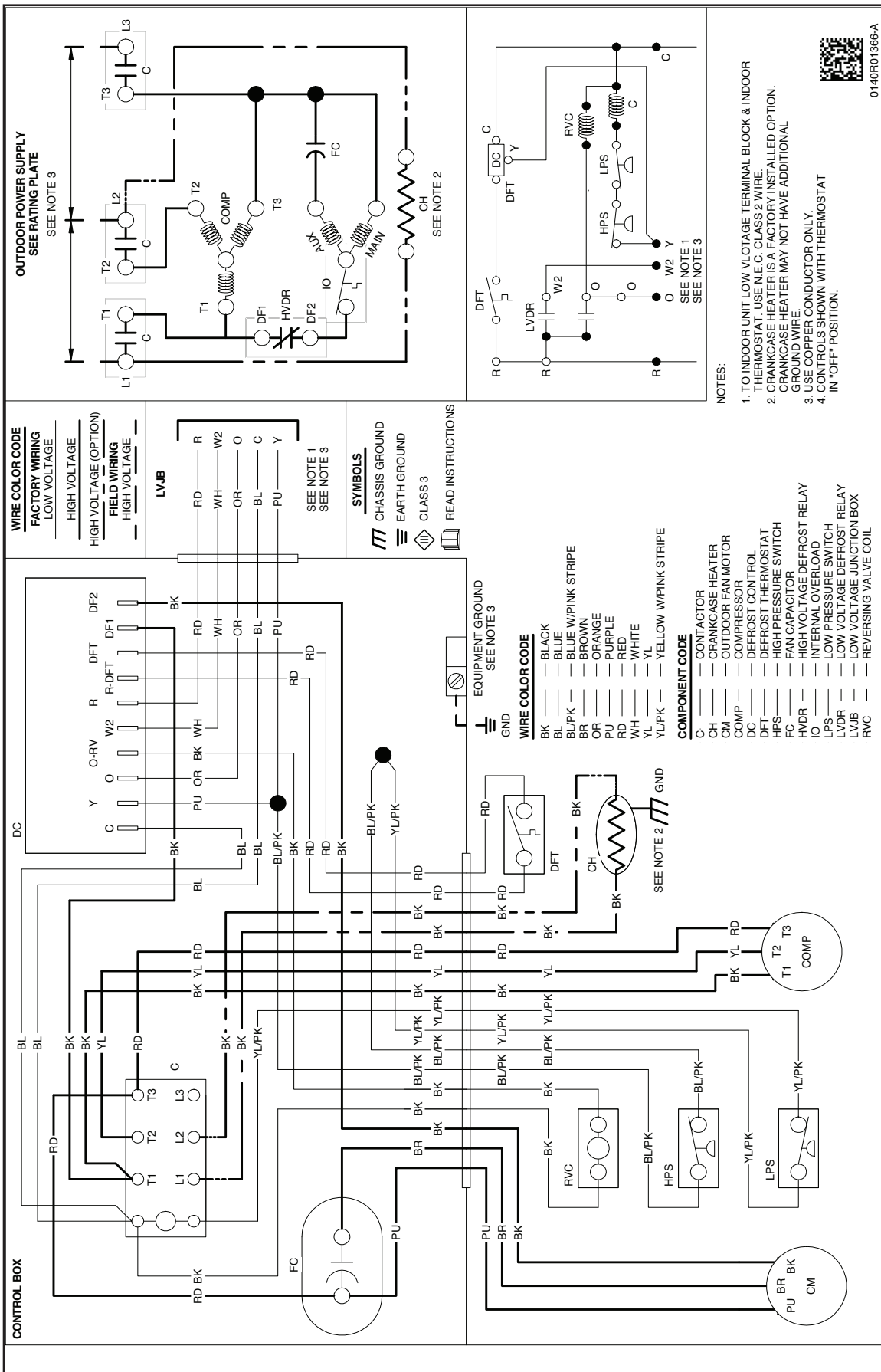

WARNING

High Voltage: Disconnect all power before servicing or installing this unit. Multiple power sources may be present. Failure to do so may cause property damage, personal injury, or death.

Wiring is subject to change. Always refer to the wiring diagram or the unit for the most up-to-date wiring.

MODEL #	DESCRIPTION	DH4SEA 3630*/3640*	DH4SEA 4830*/4840*	DH4SEA 6030*/6040*
ABK-20	Anchor Bracket Kit ◊	X	X	X
ASC01A	Anti-Short Cycle Kit	X	X	X
FSK01A ¹	Freeze Protection Kit	X	X	X
LSK02B	Liquid Line Solenoid Kit	X	X	X
LAKT01	Low-Ambient Kit	X	X	X
OT18-60A ²	Outdoor Thermostat w/ Lockout Stat	X	X	X

[^] Contains 20 brackets; four brackets needed to anchor unit to pad

¹ Installed on indoor coil

² Required for heat pump applications where ambient temperatures fall below 0°F with 50% or higher relative humidity.

