

# AMST\*\*\*U1400\*\*

## AIR HANDLERS INSTALLATION & OPERATING INSTRUCTIONS

© 2021-2023  
**DAIKIN COMFORT TECHNOLOGIES MANUFACTURING, L.P.**  
 19001 Kermier Rd., Waller, TX 77484  
[www.daikinac.com](http://www.daikinac.com)  
 P/N: IO-4004B Date: March 2023

### Contents

<b>1 Important Safety Instructions</b> .....	2
<b>2 Shipping Inspection</b> .....	3
2.1 Parts.....	3
2.2 Handling.....	3
2.3 Shipping Material Removal.....	3
2.3.1 Blower Support Bracket Removal.....	3
<b>3 Codes &amp; Regulations</b> .....	3
<b>4 Replacement Parts</b> .....	4
<b>5 Pre-Installation Considerations</b> .....	4
5.1 Preparation.....	4
5.2 System Matches.....	4
5.3 Interconnecting Tubing.....	4
5.4 Clearances.....	4
5.5 Horizontal Applications.....	4
<b>6 Installation Location</b> .....	4
6.1 Upflow Installation.....	5
6.2 Horizontal Left Installation.....	5
6.3 Horizontal Right Installation / Downflow Installation.....	5
6.4 Humid Environment Installations.....	6
6.4.1 All Installations – Humid Environments.....	6
6.4.1.2 Downflow Installations – Humid Environments.....	6
6.4.1.3 Horizontal Installations – Humid Environments.....	6
<b>7 Refrigerant Lines</b> .....	7
7.1 Tubing Size.....	7
7.2 Tubing Preparation.....	7
7.3 Tubing Connections.....	7
7.4 Thermal Expansion Valve System Adjustment.....	9
<b>8 Condensate Drain Lines</b> .....	10
<b>9 Ductwork</b> .....	11
9.1 Return Ductwork.....	11
<b>10 Return Air Filters</b> .....	11
<b>11 Electric Heat</b> .....	11
<b>12 Electrical and Control Wiring</b> .....	12
12.1 Building Electrical Service Inspection.....	12
12.2 Wire Sizing.....	12
12.3 Maximum Overcurrent Protection (MOP).....	12
12.4 Electrical Connections – Supply Voltage.....	13
12.4.1 Air Handler Only (Non-Heat Kit Models).....	13
12.4.2 Air Handler - Non-Circuit Breaker Heat Kits.....	13
12.4.3 Air Handler With Circuit Breaker Heat Kit.....	13
12.5 Low Voltage Connections.....	13
12.5.1 Thermostats.....	13
12.6 Speed Tap Adjustment.....	14
12.6.1 Selecting Speed Taps 1-5.....	14
12.6.2 Selecting Speed Taps 6-9.....	14
12.6.3 AMST60DU1400** (ONLY).....	14
<b>13 Achieving 1.4% Low Leakage Rate</b> .....	16
<b>14 Start-Up Procedure</b> .....	16
<b>15 Regular Maintenance</b> .....	16
<b>16 Airflow Data</b> .....	17
<b>17 Air Handler Low Voltage Connections</b> .....	19
<b>18 Wiring Diagrams</b> .....	20
<b>19 Start-Up Checklist</b> .....	26



### WARNING

ONLY PERSONNEL THAT HAVE BEEN TRAINED TO INSTALL, ADJUST, SERVICE OR REPAIR (HEREINAFTER, "SERVICE") THE EQUIPMENT SPECIFIED IN THIS MANUAL SHOULD SERVICE THE EQUIPMENT. THE MANUFACTURER WILL NOT BE RESPONSIBLE FOR ANY INJURY OR PROPERTY DAMAGE ARISING FROM IMPROPER SERVICE OR SERVICE PROCEDURES. IF YOU SERVICE THIS UNIT, YOU ASSUME RESPONSIBILITY FOR ANY INJURY OR PROPERTY DAMAGE WHICH MAY RESULT. IN ADDITION, IN JURISDICTIONS THAT REQUIRE ONE OR MORE LICENSES TO SERVICE THE EQUIPMENT SPECIFIED IN THIS MANUAL, ONLY LICENSED PERSONNEL SHOULD SERVICE THE EQUIPMENT. IMPROPER INSTALLATION, ADJUSTMENT, SERVICING OR REPAIR OF THE EQUIPMENT SPECIFIED IN THIS MANUAL, OR ATTEMPTING TO INSTALL, ADJUST, SERVICE OR REPAIR THE EQUIPMENT SPECIFIED IN THIS MANUAL WITHOUT PROPER TRAINING MAY RESULT IN PRODUCT DAMAGE, PROPERTY DAMAGE, PERSONAL INJURY OR DEATH.

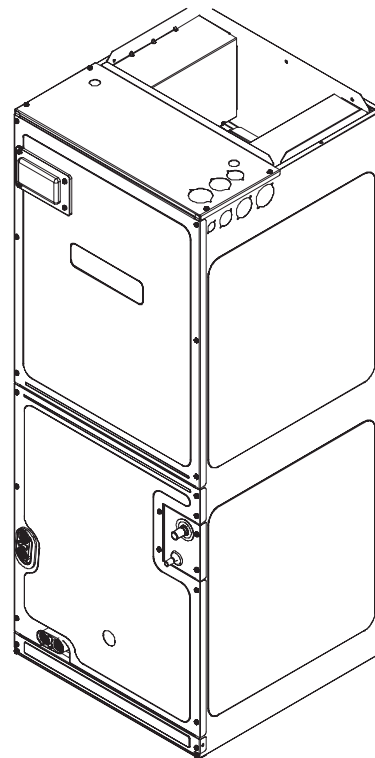

**RECOGNIZE THIS SYMBOL  
 AS A SAFETY PRECAUTION.**

NOTE: SPECIFICATIONS AND PERFORMANCE DATA LISTED HEREIN ARE SUBJECT TO CHANGE WITHOUT NOTICE





## WARNING

### HIGH VOLTAGE

DISCONNECT ALL POWER BEFORE SERVICING OR INSTALLING THIS UNIT. MULTIPLE POWER SOURCES MAY BE PRESENT. FAILURE TO DO SO MAY CAUSE PROPERTY DAMAGE, PERSONAL INJURY OR DEATH.



## WARNING

TO PREVENT THE RISK OF PROPERTY DAMAGE, PERSONAL INJURY, OR DEATH, DO NOT STORE COMBUSTIBLE MATERIALS OR USE GASOLINE OR OTHER FLAMMABLE LIQUIDS OR VAPORS IN THE VICINITY OF THIS UNIT.



## WARNING

THIS PRODUCT IS FACTORY-SHIPED FOR USE WITH 208/240/1/60 ELECTRICAL POWER SUPPLY. **DO NOT** RECONFIGURE THIS AIR HANDLER TO OPERATE WITH ANY OTHER POWER SUPPLY.



## CAUTION

WHEN INSTALLING OR SERVICING THIS EQUIPMENT, SAFETY CLOTHING, INCLUDING HAND AND EYE PROTECTION, IS STRONGLY RECOMMENDED. IF INSTALLING IN AN AREA THAT HAS SPECIAL SAFETY REQUIREMENTS (HARD HATS, ETC.), OBSERVE THESE REQUIREMENTS.



## WARNING

TO AVOID PROPERTY DAMAGE, PERSONAL INJURY OR DEATH DUE TO ELECTRICAL SHOCK, THIS UNIT MUST HAVE AN **UNINTERRUPTED, UNBROKEN** ELECTRICAL GROUND. THE ELECTRICAL GROUND CIRCUIT MAY CONSIST OF AN APPROPRIATELY SIZED ELECTRICAL WIRE CONNECTING THE GROUND LUG IN THE UNIT CONTROL BOX TO THE BUILDING ELECTRICAL SERVICE PANEL.

OTHER METHODS OF GROUNDING ARE PERMITTED IF PERFORMED IN ACCORDANCE WITH THE NATIONAL ELECTRIC CODE (NEC) / AMERICAN NATIONAL STANDARDS INSTITUTE (ANSI) / NATIONAL FIRE PROTECTION ASSOCIATION (NFPA) 70 AND LOCAL/STATE CODES. IN CANADA, ELECTRICAL GROUNDING IS TO BE IN ACCORDANCE WITH THE CANADIAN ELECTRIC CODE (CSA) C22.1.



## CAUTION

THIS APPLIANCE IS NOT INTENDED FOR USE BY PERSONS (INCLUDING CHILDREN) WITH REDUCED PHYSICAL, SENSORY OR MENTAL CAPABILITIES, OR LACK OF EXPERIENCE AND KNOWLEDGE, UNLESS THEY HAVE BEEN GIVEN SUPERVISION OR INSTRUCTION CONCERNING USE OF THE APPLIANCE BY A PERSON RESPONSIBLE FOR THEIR SAFETY. CHILDREN SHOULD BE SUPERVISED TO ENSURE THAT THEY DO NOT PLAY WITH THE APPLIANCE.



## DANGER PELIGRO



### CARBON MONOXIDE POISONING HAZARD

Special Warning for Installation of Furnace or Air Handling Units in Enclosed Areas such as Garages, Utility Rooms or Parking Areas

Carbon monoxide producing devices (such as an automobile, space heater, gas water heater, etc.) should not be operated in enclosed areas such as unventilated garages, utility rooms or parking areas because of the danger of carbon monoxide (CO) poisoning resulting from the exhaust emissions. If a furnace or air handler is installed in an enclosed area such as a garage, utility room or parking area and a carbon monoxide producing device is operated therein, there must be adequate, direct outside ventilation.

This ventilation is necessary to avoid the danger of CO poisoning which can occur if a carbon monoxide producing device continues to operate in the enclosed area. Carbon monoxide emissions can be (re)circulated throughout the structure if the furnace or air handler is operating in any mode.

CO can cause serious illness including permanent brain damage or death.

B10259-216

### RIESGO DE INTOXICACIÓN POR MONÓXIDO DE CARBONO

Advertencia especial para la instalación de calentadores ó amanejadoras de aire en áreas cerradas como estacionamientos ó cuartos de servicio.

Los equipos ó aparatos que producen monóxido de carbono (tal como automóvil, calentador de gas, calentador de agua por medio de gas, etc) no deben ser operados en áreas cerradas debido al riesgo de envenenamiento por monóxido de carbono (CO) que resulta de las emisiones de gases de combustión. Si el equipo ó aparato se opera en dichas áreas, debe existir una adecuada ventilación directa al exterior.

Esta ventilación es necesaria para evitar el peligro de envenenamiento por CO, que puede ocurrir si un dispositivo que produce monóxido de carbono sigue operando en el lugar cerrado.

Las emisiones de monóxido de carbono pueden circular a través del aparato cuando se opera en cualquier modo.

El monóxido de carbono puede causar enfermedades severas como daño cerebral permanente ó muerte.

B10259-216

### RISQUE D'EMPOISONNEMENT AU MONOXYDE DE CARBONE

Avertissement special au sujet de l'installation d'appareils de chauffage ou de traitement d'air dans des endroits clos, tels les garages, les locaux d'entretien et les stationnements.

Évitez de mettre en marche les appareils produisant du monoxyde de carbone (tels que les automobile, les appareils de chauffage autonome, etc.) dans des endroits non ventilés tels que les d'empoisonnement au monoxyde de carbone. Si vous devez faire fonctionner ces appareils dans un endroit clos, assurez-vous qu'il y ait une ventilation directe provenant de l'exterieur.

Cette ventilation est nécessaire pour éviter le danger d'intoxication au CO pouvant survenir si un appareil produisant du monoxyde de carbone continue de fonctionner au sein de la zone confinée.

Les émissions de monoxyde de carbone peuvent être recirculées dans les endroits clos, si l'appareil de chauffage ou de traitement d'air sont en marche.

Le monoxyde de carbone peut causer des maladies graves telles que des dommages permanents au cerveau et même la mort.

B10259-216

## 1 Important Safety Instructions

The following symbols and labels are used throughout this manual to indicate immediate or potential safety hazards. It is the owner's and installer's responsibility to read and comply with all safety information and instructions accompanying these symbols. Failure to heed safety information increases the risk of personal injury, property damage, and/or product damage.

## 2 Shipping Inspection

Always transport the unit upright; laying the unit on its side or top during transit may cause equipment damage. The installer should inspect the product upon receipt for shipping damage and subsequent investigation is the responsibility of the carrier. The installer must verify the model number, specifications, electrical characteristics, and accessories are correct prior to installation. The distributor or manufacturer will not accept claims from dealers for transportation damage or installation of incorrectly shipped units.

### 2.1 PARTS

Inspect the unit to verify all required components are present and intact. Report any missing components immediately to the manufacturer or to the distributor. Use only factory authorized replacement parts (see Section 5). Make sure to include the full product model number and serial number when reporting and/or obtaining service parts.

### 2.2 HANDLING

Use caution when transporting / carrying the unit. Do not move unit using shipping straps. Do not carry unit with hooks or sharp objects. The preferred method of carrying the unit after arrival at the job site is to carry via a two-wheel hand truck from the back or sides or via hand by carrying at the cabinet corners.

### 2.3 SHIPPING MATERIAL REMOVAL

**IMPORTANT: All Shipping Material used to protect the equipment, and the equipment's components, during transit should be removed before final installation.**

#### 2.3.1 BLOWER SUPPORT BRACKET REMOVAL

A shipping bracket (refer to Figure 1) has been factory installed in this Air Handler to prevent any unintentional damage to the blower deck assembly during transit. The shipping bracket should be removed prior to installation. To remove the shipping bracket, remove the two (2) screws that secure the bracket to the equipment. Screw (a) is removed from the control deck and Screw (b) is removed from the inside corner post. The bracket can be discarded after removal.

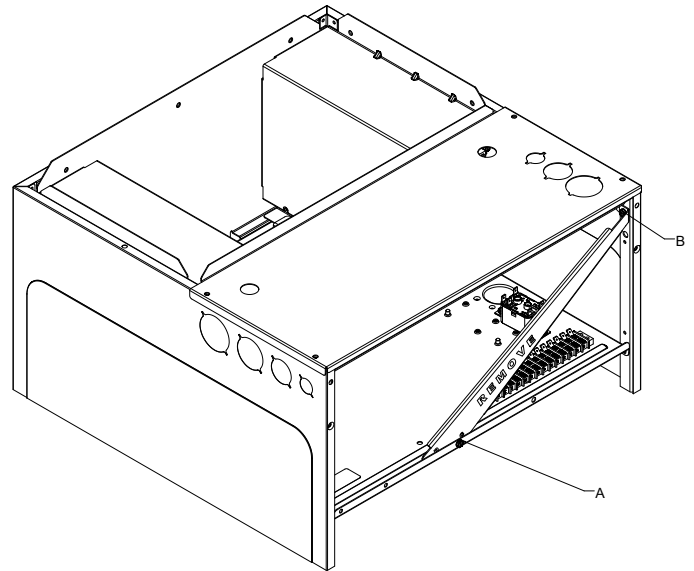
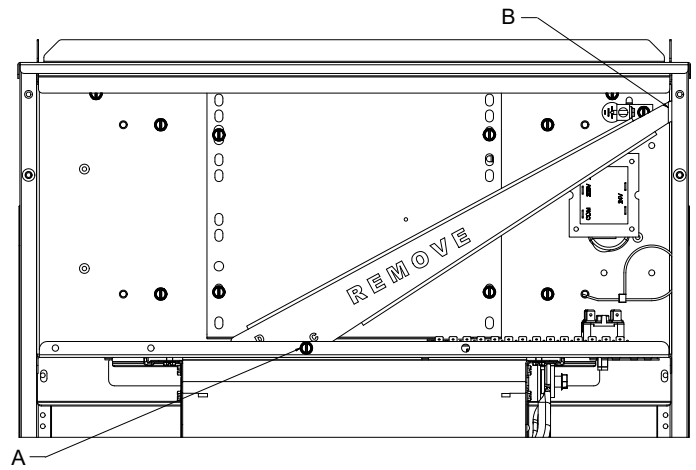

**FIGURE 1  
BLOWER SUPPORT BRACKET REMOVAL**

## 3 Codes & Regulations

This product is designed and manufactured to comply with applicable national codes. Installation in accordance with such codes and / or prevailing local codes / regulations is the responsibility of the installer. The manufacturer assumes no responsibility for equipment installed in violation of any codes or regulations.

**The United States Environmental Protection Agency (EPA) has issued various regulations regarding the introduction and disposal of refrigerants. Failure to follow these regulations may harm the environment and can lead to the imposition of substantial fines.** Should you have any questions please contact the local office of the EPA and / or refer to EPA's website [www.epa.gov](http://www.epa.gov).

## 4 Replacement Parts

When reporting shortages or damages, or ordering repair parts, give the complete product model and serial numbers as stamped on the product. Replacement parts for this product are available through your contractor or local distributor. For the location of your nearest distributor consult the white business pages, the yellow page section of the local telephone book or contact:

HOMEOWNER SUPPORT  
19001 KERMIER ROAD  
WALLER, TEXAS 77484  
(855) 770-5678

## 5 Pre-Installation Considerations

### 5.1 PREPARATION

Keep this document with the unit. Carefully read all instructions for the installation prior to installing product. Make sure each step or procedure is understood and any special considerations are taken into account before starting installation. Assemble all tools, hardware and supplies needed to complete the installation. Some items may need to be purchased locally. Make sure everything needed to install the product is on hand before starting.

### 5.2 SYSTEM MATCHES

The entire system (combination of indoor and outdoor sections) must be manufacturer approved and Air-Conditioning, Heating, and Refrigeration Institute (AHRI) listed. **NOTE:** Installation of unmatched systems is not permitted.

### 5.3 INTERCONNECTING TUBING

Give special consideration to minimize the length of refrigerant tubing when installing air handlers. Refer to Remote Cooling / Heat Pump Service Manual RS6200006, and TP-107 Long Line Set Application R-410A for tubing guidelines. If possible, allow adequate length of tubing such that the coil may be removed (for inspection or cleaning services) from the cabinet without disconnecting the tubing.

### 5.4 CLEARANCES

The unit clearance from a combustible surface may be 0". However, service clearance must take precedence. A minimum of 24" in front of the unit for service clearance is required. Additional clearance on one side or top will be required for electrical wiring connections. Consult all appropriate regulatory codes prior to determining final clearances. When installing this unit in an area that may become wet (such as crawl spaces), elevate the unit with a sturdy, non-porous material. In installations that may lead to physical damage (i.e. a garage) it is advised to install a protective barrier to prevent such damage. Always install units such that a positive slope in condensate line (1/4" per foot) is allowed.

## 5.5 HORIZONTAL APPLICATIONS

If installed above a finished living space, a secondary drain pan (as required by many building codes), must be installed under the entire unit and its condensate drain line must be routed to a location such that the user will see the condensate discharge.

## 6 Installation Location

**NOTE:** These air handlers are designed for *indoor installation only* at a max altitude of 10,500 feet above sea level or a min altitude of -184 feet below sea level.

If the unit is located in an unconditioned area with high ambient temperature and/or high humidity, the air handler may be subject to nuisance sweating of the casing. On these installations, a wrap of 2" fiberglass insulation with a vapor barrier is recommended. A secondary drain pan below the unit is also recommended to protect the installation site.

This product line may be installed in one of the upflow, downflow, horizontal left or horizontal right orientations as shown in Figures 2, 3, 4 and 5. The unit may be installed in upflow or horizontal left orientation as shipped (refer to specific sections for more information).

**FOR UPFLOW AND DOWNFLOW INSTALLATIONS ONLY**  
**Side Drain Pan and Extension Removal:** Refer to Figure 1, remove the two (2) screws that secure the drip shield support brackets to the condensate collectors (front and back). Unsnap the side drain pan from the bottom drain pan using a screw driver or any small lever. The side drain pan, drip shield brackets and the drain pan extension may now be removed. From Figure 1, drain port labeled (A) is the primary drain for this application and condensate drain line must be attached to this drain port. Drain port (a) is for the secondary drain line (if used). If the side drain pan is removed, the drain port opening in the access panel must be covered by the accessory drain port plug (DPK1) as shown in figure 1.1.

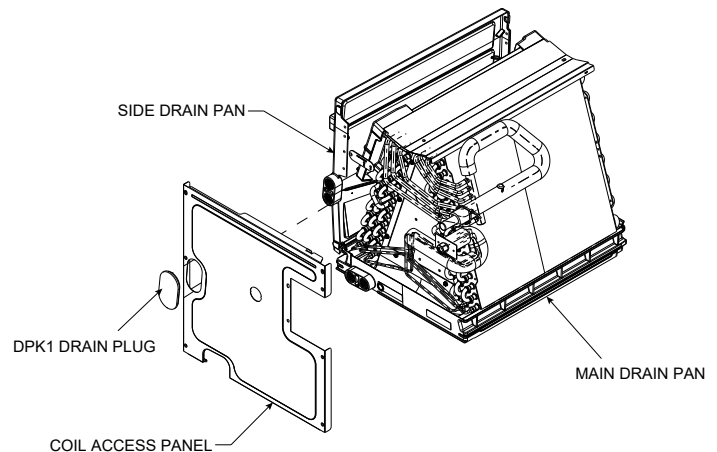

**DRAIN PAN  
FIGURE 1.1**

Drain Port Plug		
Kit Number	Description	Application
DPK1	Side Drain Port Plug	All Models

**DRAIN PORT PLUG KIT**  
**TABLE 1**

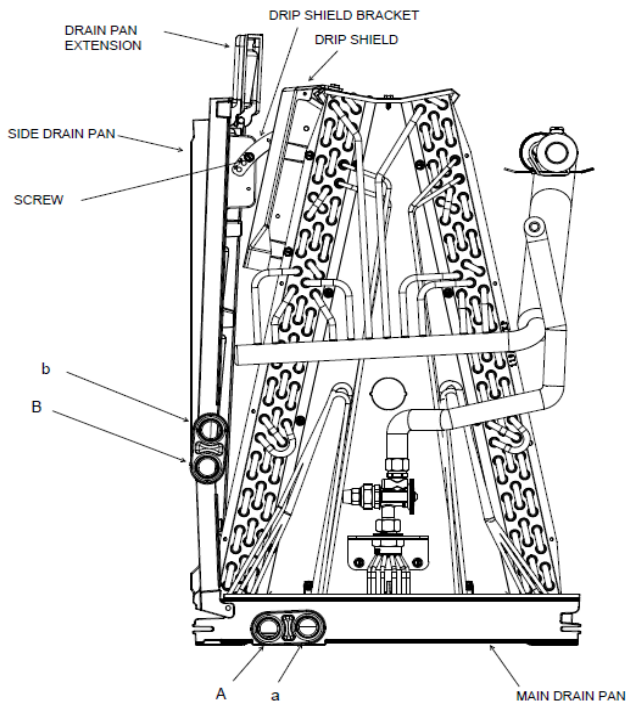

**SIDE DRAIN PAN REMOVAL**  
**FIGURE 2**

### 6.1 UPFLOW INSTALLATION

No field modifications are mandatory, but to obtain maximum efficiency, the horizontal drip shield, side drain pan and drain pan extension can be removed. See previous "Side Drain Pan and Extension Removal" instructions.

### 6.2 HORIZONTAL LEFT INSTALLATION

No field modifications are permissible for this application. Install unit as shown in Figure 4.

Drain port labeled (B) in Figure 1 is the primary drain for this application and condensate drain line must be attached to this drain port. Drain port (b) is for the secondary drain line (if used).

Remove red plugs from side drain pan before connecting condensate drain pipes. Use removed plug to close drain ports on vertical drain pan. The bottom right drain connection in side drain pan is the primary drain for this application and condensate drain line must be attached to this drain connection. The bottom left drain connection in side drain pan is for the secondary drain line (if used).

### 6.3 HORIZONTAL RIGHT INSTALLATION / DOWNFLOW INSTALLATION

**NOTE: For AMST24BU1400\*\* only: If installing a filter, an external filter must be used when installing the unit in Horizontal Right, or if the side drain pan is not removed for Down Flow application. A filter will not fit on the internal filter rails in these applications.**

Side drain pan extension must be removed in the downflow and horizontal right applications for all models.

Refer to Figure 6 and 7 for the location of the components referenced in the following steps.

1. Before inverting the air handler, remove blower access panel and coil access panel. The coil access panel and tubing panel may remain screwed together during this procedure. Remove and retain the seven (7) screws securing the coil access panel to the cabinet and the six (6) screws securing the blower access panel to the cabinet.
2. Slide the coil assembly out from the cabinet. Use the drain pan to pull the assembly from the cabinet.

**NOTE: Do not use manifolds, copper lines, or the flowrator to pull the coil assembly out. Failure to do so may result in braze joint damage and leaks.**

3. Removal of the center support is required on units with 21" wide cabinet. Remove and retain the two (2) screws that secure the center support to the cabinet. Remove the center support.
4. Position the unit in the downflow position.
5. Using the drain pan to hold the coil assembly, slide the coil assembly back into the cabinet on the downflow brackets as shown in Figure 8.
6. Reinstall the center support (if removed) using the two (2) screws removed in Step 5.
7. Reinstall the coil access panels and reinstall blower access panel removed in Step 1 as shown in Figure 9.
8. Drain Connections for Horizontal Right Installation
  - a. The bottom right drain connection in side drain pan is the primary drain for this application and condensate drain line must be attached to this drain connection. The bottom left drain connection is for the secondary drain line (if used).
  - b. Remove red plugs from side drain pan before connecting condensate drain pipes. Use removed plug to close drain ports on vertical drain pan.
9. Drain Connections for Downflow Installation
  - a. The bottom left drain connection in the vertical drain pan is the primary drain for this application and condensate drain line must be attached to this drain connection. The bottom right drain connection is for the secondary drain line (if used).
  - b. Remove red plugs from vertical drain pan before connecting condensate drain pipes.

**NOTE:** If removing only the coil access panel from the unit, the filter access panel must be removed first. Failure to do so will result in panel damage.

**6.4 HUMID ENVIRONMENT INSTALLATIONS**

**NOTE:** Each service kit mentioned in this instruction is available through your local distributor. The kits are not supplied with the air handler and must be used to assist with condensation management in humid environment applications. The individual installation instructions provided with each kit must be followed.

**6.4.1 ALL INSTALLATIONS – HUMID ENVIRONMENTS**

Installations in areas where the return air environment sees humidity levels above 65% relative humidity, a High Humidity Kit (HHK) must be used. See Table 2 for Model and Kit assignment.

HHK0004	HHK0005	HHK0006	HHK0007	HHK0008
AMST24B AMST30B AMST36B	AMST36C AMST42C AMST48C	AMST48C	AMST48D	AMST60D

**TABLE 2**

**6.4.1.2 DOWNFLOW INSTALLATIONS – HUMID ENVIRONMENTS**

The Side Drain Pan must be removed when the unit is installed in downflow application in humid environments. To prevent the coil pan “sweating”, the mandatory Downflow Kit (DFK) must also be used in addition to the High Humidity Kit (HHK). See Table 3 for the correct DFK for each model.

DFKE-02	DFKE-03
AMST24B AMST30B AMST36B AMST36C AMST42C	AMST48C AMST48D AMST60D

**TABLE 3**

**6.4.1.3 HORIZONTAL INSTALLATIONS – HUMID ENVIRONMENTS**

In addition to the High Humidity Kit (HHK), in applications where the air handler is installed in the horizontal position (Left or Right), and the return air environment sees humidity levels above 65% relative humidity, a Condensate Management Kit (CMK) must be used for field application. Applicable Kit and Model listing can be found in Table 4.

CMK0018	CMK0019	CMK0020
AMST24B AMST36C	AMST30B AMST36B AMST42C	AMST48C AMST48D AMST60D

**TABLE 4**

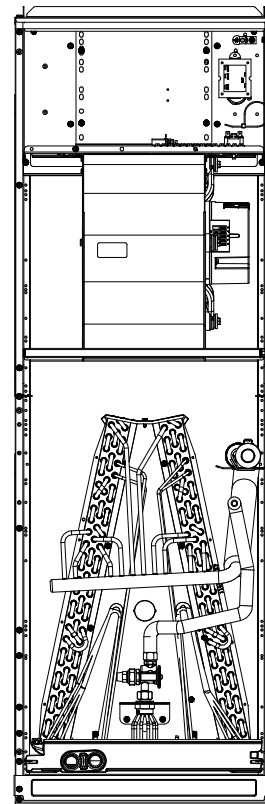

**UPFLOW**

**FIGURE 3**

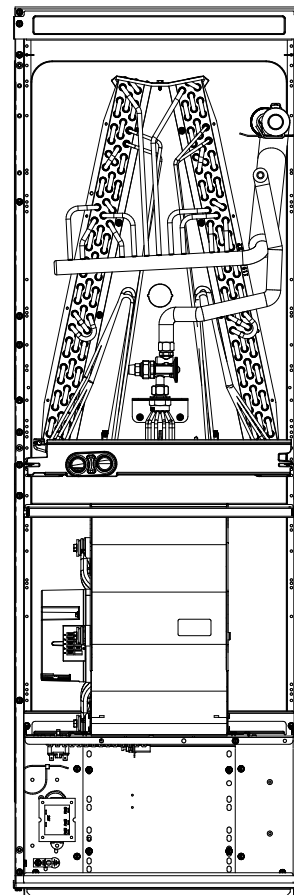

**DOWNFLOW**

**FIGURE 4**

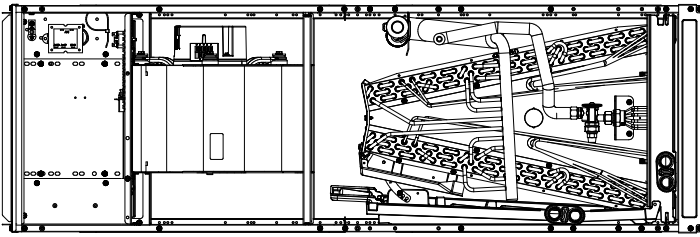

HORIZONTAL LEFT

FIGURE 5

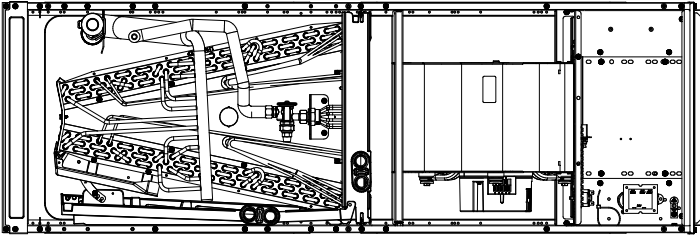

HORIZONTAL RIGHT

FIGURE 6

recommended when brazing to avoid burning the serial plate or the finish of the unit. Heat trap or wet rags must be used to protect heat sensitive components such as service valves and TXV valves sensing bulb.



**WARNING**

A QUENCHING CLOTH IS STRONGLY RECOMMENDED TO PREVENT SCORCHING OR MARRING OF THE EQUIPMENT FINISH WHEN BRAZING CLOSE TO THE PAINTED SURFACES. USE BRAZING ALLOY OF 5% MINIMUM SILVER CONTENT.



**CAUTION**

APPLYING TOO MUCH HEAT TO ANY TUBE CAN MELT THE TUBE. TORCH HEAT REQUIRED TO BRAZE TUBES OF VARIOUS SIZES MUST BE PROPORTIONAL TO THE SIZE OF THE TUBE. SERVICE PERSONNEL MUST USE THE APPROPRIATE HEAT LEVEL FOR THE SIZE OF THE TUBE BEING BRAZED.

**7 Refrigerant Lines**



**WARNING**

THIS PRODUCT IS FACTORY-SHIPED WITH R410A AND DRY NITROGEN MIXTURE GAS UNDER PRESSURE. USE APPROPRIATE SERVICE TOOLS AND FOLLOW THESE INSTRUCTIONS TO PREVENT INJURY.

**NOTE:** Refrigerant tubing must be routed to allow adequate access for servicing and maintenance of the unit. Do not install the air handler in a location that violates the instructions provided with the condenser. If the unit is located in an unconditioned area with high ambient temperature and/or high humidity, the air handler may be subject to nuisance sweating of the air handler cabinet. On these installations, a wrap of 2" fiberglass insulation with a vapor barrier is recommended.

**7.1 TUBING SIZE**

For the correct tubing size, follow the specification for the condenser/heat pump.

**7.2 TUBING PREPARATION**

All cut ends are to be round, burr free, and clean. Failure to follow this practice increases the chances for refrigerant leaks. The suction line is spun closed and requires tubing cutters to remove the closed end.

**NOTE:** To prevent possible damage to the tubing joints, do not handle coil assembly with manifold or flowrator tubes. Always use clean gloves when handling coil assemblies.

**NOTE:** The use of a heat shield is strongly

**7.3 TUBING CONNECTIONS**

An adjustable TXV with bulb is installed on the vapor tube from the factory.

1. Remove refrigerant tubing panel or coil (lower) access panel.
2. Remove access valve fitting cap and depress the valve stem in access fitting to release pressure. No pressure indicates possible leak.
3. Replace the panel.
4. Remove the spin closure on both the liquid and suction tubes using a tubing cutter.
5. Insert liquid line set into liquid tube expansion and slide grommet about 18" away from braze joint.
6. Insert suction line set into suction tube expansion and slide insulation and grommet about 18" away from braze joint.
7. Braze joints. Quench all brazed joints with water or a wet rag upon completion of brazing.

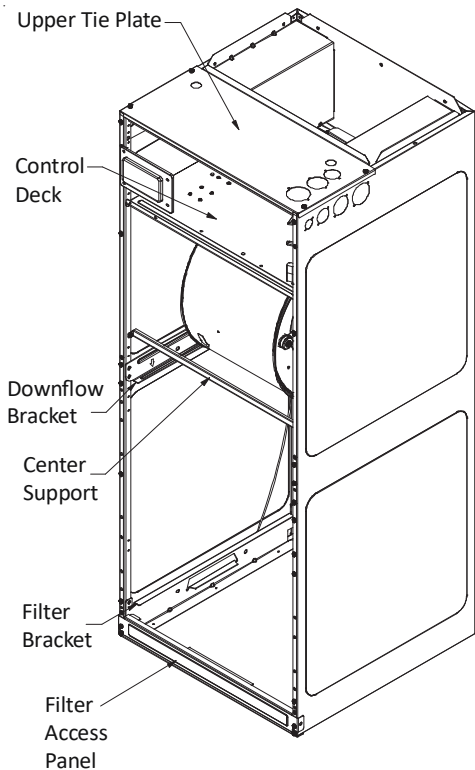

**INTERNAL PART TERMINOLOGY  
FIGURE 7**

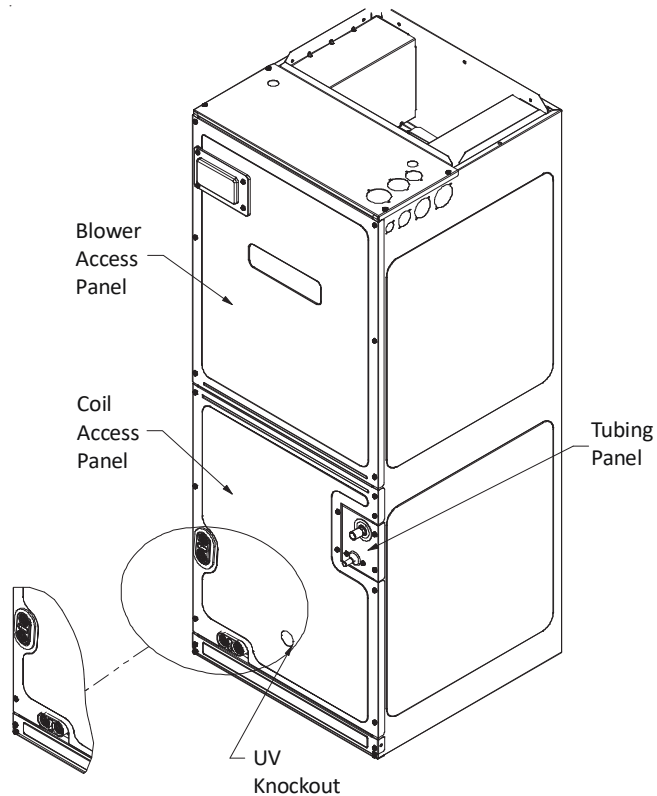

**EXTERNAL PART TERMINOLOGY  
FIGURE 8**

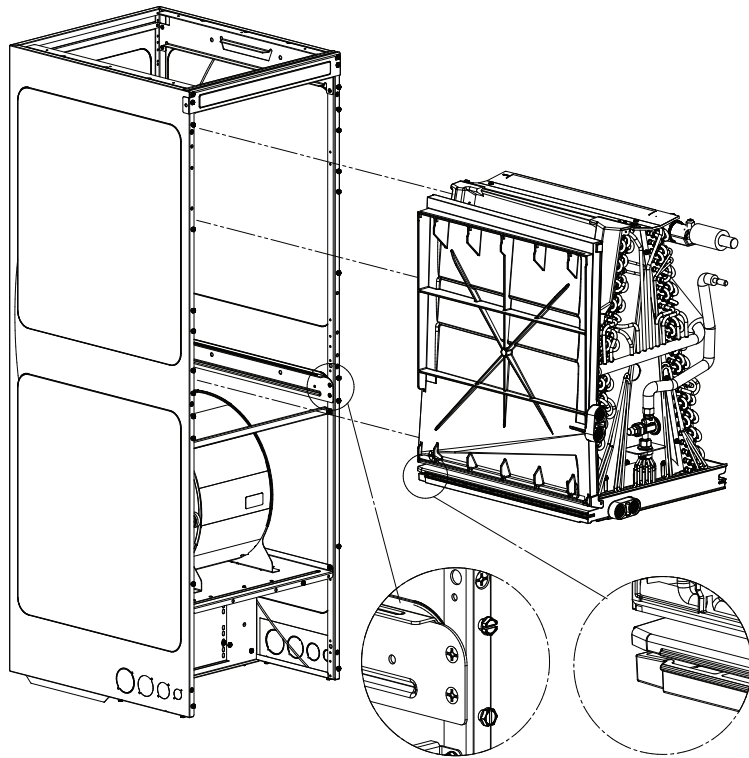

**COIL INSTALLATION FOR DOWNFLOW  
FIGURE 9**

**Important Note:** Ensure coil slides on the rails along the groove provided on the drain pan side walls. Failure to do so will result in improper condensate drainage.

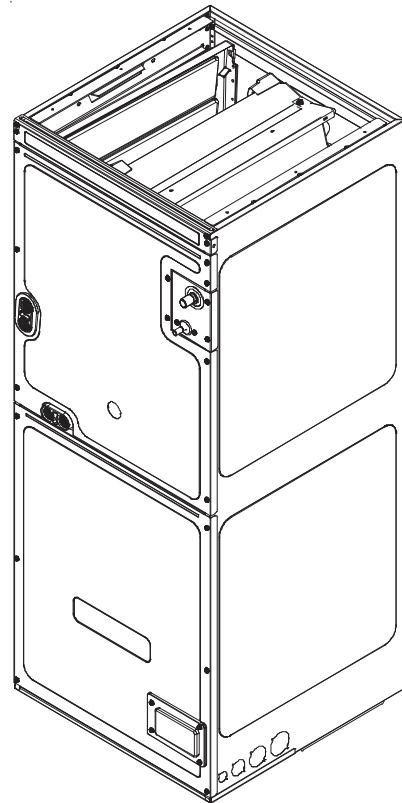

**ACCESS PANEL CONFIGURATION FOR DOWNFLOW OR  
HORIZONTAL RIGHT  
FIGURE 10**

#### 7.4 THERMAL EXPANSION VALVE SYSTEM ADJUSTMENT

The following information for the indoor unit should be verified before attempting to charge system or adjust TXV if necessary.

1. Total static pressure is .5" WC or less.
2. Airflow is correct for installed unit.
3. Airflow tables are in the installation manual and Spec Sheet for Indoor Unit.
4. Complete airflow tables and charging information are in Service Manual RS6200006
5. The outdoor temperature must be 60°F or higher.
6. Set the room thermostat to COOL, fan switch to AUTO
7. Set the temperature control well below room temperature.

Superheat adjustments should not be made until indoor ambient conditions have stabilized. This could take up to 24 hours depending on indoor temperature and humidity. Before checking superheat run the unit in cooling for 10 minutes or until refrigerant pressures stabilize. Use the following guidelines and methods to check unit operation and ensure that the refrigerant charge is within limits.

NOTE: Charge two stage units on low stage.

1. Purge gauge lines. Connect service gauge manifold to base-valve service ports.
2. Temporarily install a thermometer on the liquid line at the liquid line service valve and 4-6" from the compressor on the suction line. Ensure the thermometer makes adequate contact and is insulated for best possible readings. Use liquid line temperature to determine subcooling and vapor temperature to determine superheat.
3. Check subcooling and superheat. The system should have a subcooling of 8°F +/- 1°F and two-stage compressor systems should have a Subcooling of 6°F +/- 1°F. and superheat of 8°F +/- 1°F. If subcooling and superheat are low, adjust TXV to 8°F +/- 1°F superheat, then check subcooling.
  - a. If subcooling is low and superheat is high, add charge to raise subcooling to 8°F +/- 1°F. Two-stage compressor systems should have a Subcooling of 6°F +/- 1°F then check superheat.
  - b. If subcooling and superheat are high, adjust TXV valve to 8°F +/- 1°F superheat, then check subcooling.

#### Superheat Adjustments (Only if necessary)

1. Attach a pipe clamp thermometer near the suction line service valve at the outdoor unit.
  - a. Ensure the thermometer makes adequate contact for the best possible readings.
2. TXV-based systems should have a Superheat value of 8°F +/- 1°F.

3. Adjust Superheat by turning the TXV valve stem clockwise to **increase** and **counterclockwise** to **decrease**. Adjustments should be made opening or closing the valve by no more than ¼ turn at a time. Allow the system to stabilize 15 to 20 minutes before making additional adjustments if necessary.
4. After adjustments are complete replace cap on adjustment stem and tighten 1/6 turn.
5. Remove gauges and check the Schrader ports for leaks and tighten valve cores if necessary. Install caps finger tight.

**NOTE: In situations where the TXV must be removed and replaced or re-installed into the system, the TXV should be hand tightened first and then apply a half turn to fully set the TXV. No more than 20 ft-lb torque should be applied to the joints of the TXV.**

SATURATED SUCTION PRESSURE TEMPERATURE CHART	
SUCTION PRESSURE	SATURATED SUCTION
PSIG	R-410A
50	1
52	3
54	4
56	6
58	7
60	8
62	10
64	11
66	13
68	14
70	15
72	16
74	17
76	19
78	20
80	21
85	24
90	26
95	29
100	31
110	36
120	41
130	45
140	49
150	53
160	56
170	60

TABLE 5

**SUBCOOL FORMULA = SAT. LIQUID LINE TEMP. - LIQUID LINE TEMP.**  
**SUPERHEAT FORMULA = SUCT. LINE TEMP. - SAT. SUCT. TEMP.**

SATURATED LIQUID PRESSURE TEMPERATURE CHART	
LIQUID PRESSURE	SATURATED LIQUID TEMPERATURE °F
PSIG	R-410A
200	70
210	73
220	76
225	78
235	80
245	83
255	85
265	88
275	90
285	92
295	95
305	97
325	101
355	108
375	112
405	118
415	119
425	121
435	123
445	125
475	130
500	134
525	138
550	142
575	145
600	149
625	152

TABLE 6

## 8 Condensate Drain Lines

The coil drain pan has a primary and a secondary drain with 3/4" NPT female connections. The connectors required are 3/4" NPT male, either PVC or metal pipe, and should be hand tightened to a torque of no more than 37 in-lbs. to prevent damage to the drain pan connection. An insertion depth of approximately 3/8" to 1/2" (3-5 turns) should be expected at this torque.

1. Ensure drain pan hole is not obstructed.
2. To prevent potential sweating and dripping on to finished space, it may be necessary to insulate the condensate drain line located inside the building. Use Armaflex® or similar material.

A secondary condensate drain connection has been provided for areas where the building codes require it. Pitch all drain lines a minimum of 1/4" per foot to provide free drainage. Provide required support to the drain line to prevent bowing.

If the secondary drain line is required, run the line separately from the primary drain and end it where condensate discharge can be easily seen.

**NOTE: Water coming from secondary line means the coil primary drain is plugged and needs immediate attention.**

 <b>CAUTION</b>
<b>IF SECONDARY DRAIN IS NOT INSTALLED, THE SECONDARY ACCESS MUST BE PLUGGED.</b>

Insulate drain lines located inside the building or above a finished living space to prevent sweating. Install a condensate trap to ensure proper drainage.

**NOTE: When units are installed above ceilings, or in other locations where damage from condensate overflow may occur, it is MANDATORY to install a field fabricated auxiliary drain pan under the coil cabinet enclosure.**

The installation must include a "P" style trap that is located as close as is practical to the evaporator coil. See Figure 12 for details of a typical condensate line "P" trap.

**NOTE: Units operating in high static pressure applications may require a deeper field constructed "P" style trap than is shown in Figure 12 to allow proper drainage and prevent condensate overflow.**

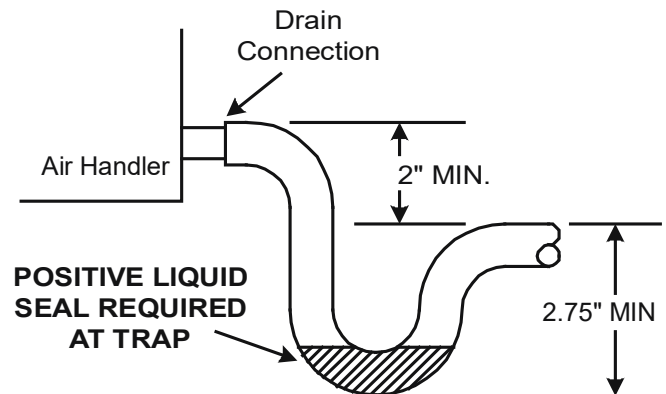

FIGURE 11

**NOTE: Trapped lines are required by many local codes. In the absence of any prevailing local codes, please refer to the requirements listed in the Uniform Mechanical Building Code.**

A drain trap in a draw-through application prevents air from being drawn back through the drain line during fan operation thus preventing condensate from draining, and if connected to a sewer line to prevent sewer gases from being drawn into the airstream during blower operation.

Use of a condensate removal pump is permitted when necessary. This condensate pump should have provisions for shutting off the control voltage should a blocked drain occur. A trap must be installed between the unit and the condensate pump.

**IMPORTANT NOTE: The evaporator coil is fabricated with oils that may dissolve styrofoam and certain types of plastics. Therefore, a removal pump or float switch must not contain any of these materials.**

Tip: Priming the “P” trap may avoid improper draining at the initial installation and at the beginning of the cooling season.

## 9 Ductwork

This air handler is designed for a complete supply and return ductwork system.



To ensure correct system performance, the ductwork is to be sized to accommodate 350-450 CFM per ton of cooling with the static pressure not to exceed 0.5” in w.c. Refer to ACCA Manual D, Manual S and Manual RS for information on duct sizing and application. Flame retardant ductwork is to be used and sealed to the unit in a manner that will prevent leakage.

**NOTE: A downflow application with electric heat must have an L-shaped sheet metal supply duct without any outlets or registers located directly below the heater.**

### 9.1 RETURN DUCTWORK

**DO NOT LOCATE THE RETURN DUCTWORK IN AN AREA THAT CAN INTRODUCE TOXIC, OR OBJECTIONABLE FUMES/ODORS INTO THE DUCTWORK.** The return ductwork is to be connected to the air handler bottom (upflow configuration).

## 10 Return Air Filters

**NOTE: For AMST24BU1400\*\* only: If installing a filter, an external filter must be used when installing the unit in Horizontal Right, or if the side drain pan is not removed for Down Flow application. A filter will not fit on the internal filter rails in these applications.**

Each installation must include a return air filter. This filtering may be performed at the air handler using the factory filter rails or externally such as a return air filter grille. When using the factory filter rails, a nominal 16x20x1”, 20x20x1” or 24x20x1” (actual dimension must be less than 23-½”x20”) filter can be installed on a B, C and D cabinet respectively (the cabinet size is the seventh letter of the model number).

## 11 Electric Heat

Refer to the installation manual provided with the electric heat kit for the correct installation procedure. All electric heat must be field installed. If installing this option, the ONLY heat kits that are permitted to be used are the HKS and HKTSD series. Refer to the air handler unit’s Serial and Rating plate or the HKS and HKTSD specification sheets to determine the heat kits compatible with a given air handler. No other accessory heat kit besides the HKS and HKTSD series may be installed in these air handlers.

The heating mode temperature rise is dependent upon the system airflow, the supply voltage, and the heat kit size (kW) selected. Use data provided in Tables 5, 6, AND 7 to determine the temperature rise (°F).

**NOTE: For installations not indicated above the following formula is to be used:**

$$TR = (kW \times 3412) \times (\text{Voltage Correction}) / (1.08 \times \text{CFM})$$

Where: TR	=	Temperature Rise
kW	=	Heater Kit Actual kW
3412	=	Btu per kW
VC*	=	.96 (230 Supply Volts)
	=	.92 (220 Supply Volts)
	=	.87 (208 Supply Volts)
1.08	=	Constant
CFM	=	Measured Airflow

\*VC (Voltage Correction)

**NOTE: The Temperature Rise Tables can also be used to estimate the air handler airflow delivery. When using these tables for this purpose set the room thermostat to maximum heat and allow the system to reach steady state conditions. Insert two thermometers, one in the return air and one in the supply air. The temperature rise is the supply air temperature minus the room air temperature. Using the temperature rise calculated, CFM can be estimated from the TR formula above. See Service Manual for more information.**

CFM	HEAT KIT NOMINAL kW							
	3	5	6	8	10	15	19/20	25
800	12	19	23	31	37			
1000	9	15	19	25	30	44		
1200	8	12	15	21	25	37	49	62
1400	7	11	13	18	21	32	42	53
1600	6	9	12	15	19	28	37	46
1800	5	8	10	14	16	25	33	41
2000	5	7	9	12	15	22	30	37

**230/1/60 SUPPLY VOLTAGE - TEMP. RISE °F  
TABLE 7**

CFM	HEAT KIT NOMINAL KW							
	3	5	6	8	10	15	19/20	25
800	11	18	22	30	35			
1000	9	14	18	24	28	42		
1200	7	12	15	20	24	35	47	59
1400	6	10	13	17	20	30	40	51
1600	6	9	11	15	18	27	35	44
1800	5	8	10	13	16	24	31	39
2000	4	7	9	12	14	21	28	35

220/1/60 SUPPLY VOLTAGE - TEMP. RISE °F

TABLE 8



CFM	HEAT KIT NOMINAL KW							
	3	5	6	8	10	15	19/20	25
800	10	17	21	28	33			
1000	8	13	17	22	27	40		
1200	7	11	14	19	22	33	45	56
1400	6	10	12	16	19	29	38	48
1600	5	8	10	14	17	25	33	42
1800	5	7	9	12	15	22	30	37
2000	4	7	8	11	13	20	27	33

208/1/60 SUPPLY VOLTAGE - TEMP. RISE °F

TABLE 9

## 12 Electrical and Control Wiring

**IMPORTANT:** All routing of electrical wiring must be made through provided electrical knockouts. Do not cut, puncture or alter the cabinet for electrical wiring.

	<b>WARNING</b>
<p><b>HIGH VOLTAGE</b> DISCONNECT ALL POWER BEFORE SERVICING OR INSTALLING THIS UNIT. MULTIPLE POWER SOURCES MAY BE PRESENT. FAILURE TO DO SO MAY CAUSE PROPERTY DAMAGE, PERSONAL INJURY OR DEATH.</p>	
	

	<b>WARNING</b>
<p><b>HIGH VOLTAGE!</b> TO AVOID PROPERTY DAMAGE, PERSONAL INJURY OR DEATH DUE TO ELECTRICAL SHOCK, THIS UNIT MUST HAVE AN <u>UNINTERRUPTED, UNBROKEN</u> ELECTRICAL GROUND. THE ELECTRICAL GROUND CIRCUIT MAY CONSIST OF AN APPROPRIATELY SIZED ELECTRICAL WIRE CONNECTING THE GROUND LUG IN THE UNIT CONTROL BOX TO THE BUILDING ELECTRICAL SERVICE PANEL. OTHER METHODS OF GROUNDING ARE PERMITTED IF PERFORMED IN ACCORDANCE WITH THE NATIONAL ELECTRIC CODE (NEC)/AMERICAN NATIONAL STANDARDS INSTITUTE (ANSI)/NATIONAL FIRE PROTECTION ASSOCIATION (NFPA) 70 AND LOCAL/STATE CODES. IN CANADA, ELECTRICAL GROUNDING IS TO BE IN ACCORDANCE WITH THE CANADIAN ELECTRIC CODE (CSA) C22.1.</p>	

### 12.1 BUILDING ELECTRICAL SERVICE INSPECTION

This unit is designed for single-phase electrical supply only. DO NOT OPERATE ON A THREE-PHASE POWER SUPPLY. Measure the power supply to the unit. The supply voltage must be measured and be in agreement with the unit nameplate power requirements and within the range shown.

### 12.2 WIRE SIZING

Wire size is important to the operation of your equipment. Use the following check list when selecting the appropriate wire size for your unit.

- Wire used must carry the Minimum Circuit Ampacity (MCA) listed on the unit's Series and Rating Plate.
- Refer to the NEC (USA) or CSA (Canada) for wire sizing. The unit MCA for the air handler and the optional electric heat kit can be found on the unit Series and Rating Plate.
- Wire must be sized to allow no more than a 2% voltage drop from the building breaker/fuse panel to the unit.
- Wires with different insulation temperature rating have varying ampacities - be sure to check the temperature rating used.

Refer to the latest edition of the National Electric Code or in Canada the Canadian Electric Code when determining the correct wire size.

### 12.3 MAXIMUM OVERCURRENT PROTECTION (MOP)

Every installation must include an NEC (USA) or CEC (Canada) approved overcurrent protection device. Also, check with local or state codes for any special regional requirements.

Protection can be in the form of fusing or HACR style circuit breakers. The Series and Rating Plate provides the maximum overcurrent device permissible.

**NOTE:** Fuses or circuit breakers are to be sized larger than the equipment MCA but not to exceed the MOP.

Model	HEATER KIT (kW)								
	3	5	6	8	10	15	19	20	25
AMST24BU14	715	715	715	715	850				
AMST30BU14	715	715	715	715	875	1050			
AMST36BU14	715	715	715	715	875	1050			
AMST36CU14		1170	1170	1170	1170	1345	1345		
AMST42CU14		1170	1170	1170	1170	1345	1345		
AMST48CU14		1170	1170	1170	1170	1345	1345		
AMST48DU14		1240	1240	1240	1240	1520		1520	
AMST60DU14		1590	1590	1590	1590	1715		1715	1930

\*AIRFLOWS SHOWN ARE TO BE CONSIDERED THE ABSOLUTE MINIMUM ALLOWABLE FOR THE AIR HANDLER AND HEAT KIT COMBINATION. THE MINIMUM AIRFLOW DOES NOT REPRESENT THE RECOMMENDED AIRFLOW BY THE MANUFACTURER. WHEN SELECTING A HEATER KIT, THE MINIMUM BLOWER SETTING (M.B.S.) OR SPEED TAP LISTED ON THE UNIT'S NAMEPLATE SHOULD BE FOLLOWED.

**MINIMUM CFM REQUIRED FOR HEATER KITS**  
**TABLE 10**

Nominal Input	Minimum Voltage	Maximum Voltage
208-230 VAC	197	253

**ELECTRICAL VOLTAGE**  
**TABLE 11**

adapter ring must be used in order to meet UL 1995 safety requirements. An NEC or CEC approved strain relief is to be used at this entry point. Some codes/municipalities require the supply wire to be enclosed in conduit. Consult your local codes.

**12.4 ELECTRICAL CONNECTIONS – SUPPLY VOLTAGE**

 <b>CAUTION</b>
<b>FIRE HAZARD!</b> <b>TO AVOID THE RISK OF PROPERTY DAMAGE, PERSONAL INJURY OR FIRE, USE ONLY COPPER CONDUCTORS.</b>

**IMPORTANT NOTE: USE COPPER CONDUCTORS ONLY FROM DISCONNECT OR ELECTRICAL PANEL TO THE AIR HANDLER.**

Knockouts are provided on the air handler top panel and sides of the cabinet to allow for the entry of the supply voltage conductors, as shown in Figure 13. Separate knockouts must be used for two circuit heat kits. Unless Single Point Wiring Kit (SPW-01) is used. If the knockouts on the cabinet sides are used for electrical conduit, an

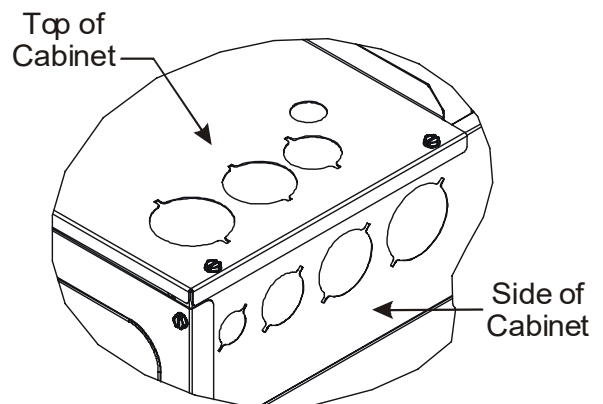

**KNOCK-OUT FOR ELECTRICAL CONNECTIONS**  
**FIGURE 12**

**12.4.1 AIR HANDLER ONLY (NON-HEAT KIT MODELS)**

**IMPORTANT:** Installation of Air Handler must follow any local codes/regulations. The manufacture recommends that when a heater kit is not installed, a field supplied disconnect switch or breaker should be installed in the electrical circuit that will allow power to be shut-off for service or maintenance.

The building supply connects to the stripped black and red wires contained in the air handler electrical compartment cavity. A ground screw is also contained in this area. Attach the Supply wires to the air handler conductors as shown in the unit wiring diagram using appropriately sized solderless connectors or other NEC or CEC approved means.

**12.4.2 AIR HANDLER - NON-CIRCUIT BREAKER HEAT KITS**

A terminal block is provided with the HKS and HKTSD kit to attach the power supply and air handler connections. Follow the HKS and HKTSD Installation Manual and wiring diagram for complete wiring details.

**12.4.3 AIR HANDLER WITH CIRCUIT BREAKER HEAT KIT**

The air handler has soft plastic cover on the upper access panel and can be removed to allow the heater kit circuit breaker to be installed. The circuit breakers have lugs for power supply connection. See the HKS and HKTSD Installation Instructions for further details.

**12.5 LOW VOLTAGE CONNECTIONS**

Several combinations of low voltage schemes are possible, depending on the presence of a heat kit and whether the heat kit is single-stage or multi-stage, whether the outdoor section is an air conditioner or heat pump, and whether the outdoor section is single-stage or two-stage. The 24V-control voltage connects the air handler to the room thermostat and condenser. Low voltage wiring must be copper conductors. A minimum of 18AWG must be used for installations up to 100 feet. Low voltage wiring must be connected through the top of the cabinet or either side. See the "Thermostat Wiring" section of this manual for typical low voltage wiring connections.

**12.5.1 THERMOSTATS**

Second-stage heat can be accomplished by a multi-stage heating thermostat or the addition of an outdoor thermostat as shown in wiring schematics on page 19. Follow the thermostat manufacturer's instructions for installation.

**12.6 SPEED TAP ADJUSTMENT**

AMST\*\*U1400\*\* air handlers feature 9-speed energy efficient blower motors. The motors run at a constant torque with very low power consumption. Changing the 24 VAC leads to the desired speed tap on the terminal block will adjust provided CFM (speed tap adjustment of the AMST60DU1400\*\* is not supported).

The AMST blower motor speeds are programmed to deliver adequate airflow at rated external static pressure and with a 60 second off time delay. For details, refer to the specification sheet applicable to your model.

**12.6.1 SELECTING SPEED TAPS 1-5 (NOT APPLICABLE TO AMST60DU1400\*\*)**

When selecting Speed Taps 1-5, move the Purple (PU) wire lead from the alternate control relay to the desired Speed Tap (Note: The labeled terminal block (TB) locations T1-T5 correlate to Speed Taps 1-5). See Table 12.

**NOTE:** When selecting Speeds Tap 1 or 5, the Black (BK) jumper should be removed completely and placed in the Literature Bag.

	OR	WH	BR	PU	YL	
	T1	T2	T3	T4	T5	TB Engaged
Tap-1	PU					T1
Tap-2		PU				T2
Tap-3			PU			T3
Tap-4				PU		T4
Tap-5					PU	T5

TABLE 12

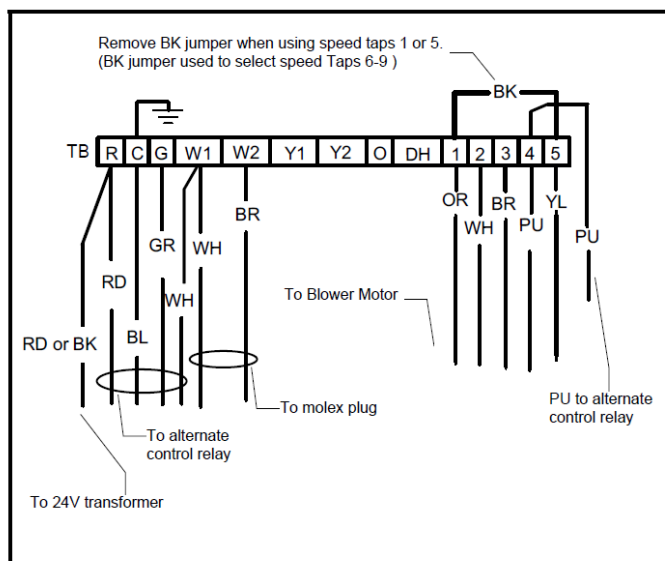

SPEED TAPS 1-5 WIRING  
FIGURE 13

**12.6.2 SELECTING SPEED TAPS 6-9 (NOT APPLICABLE TO AMST60DU1400\*\*)**

When selecting speed taps 6-9, move the Black (BK) jumper, jumping T1 to any of terminal block locations T2 - T5. This will shift the motor to the 6-9 taps when the Purple (PU) lead from the blower relay is placed on the same tap as the Black (BK) jumper. See Table 13.

	OR	WH	BR	PU	YL	
	T1	T2	T3	T4	T5	TB Engaged
Tap-6	BK	PU+BK				T1+T2
Tap-7	BK		PU+BK			T1+T3
Tap-8	BK			PU+BK		T1+T4
Tap-9	BK				PU+BK	T1+T5

**TABLE 13**

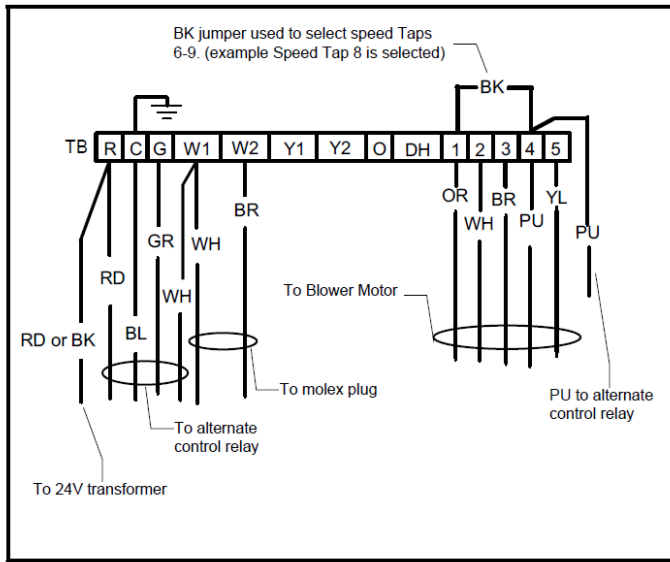

**SPEED TAPS 6-9 WIRING  
FIGURE 14**

**12.6.3 AMST60DU1400\*\* (ONLY)**

For high static applications, no speed tap or airflow modifications should be made from the factory settings. To obtain T1 airflow for low static applications, the Purple (PU) jumper between Y1 and T3 should be removed. See Table 14.

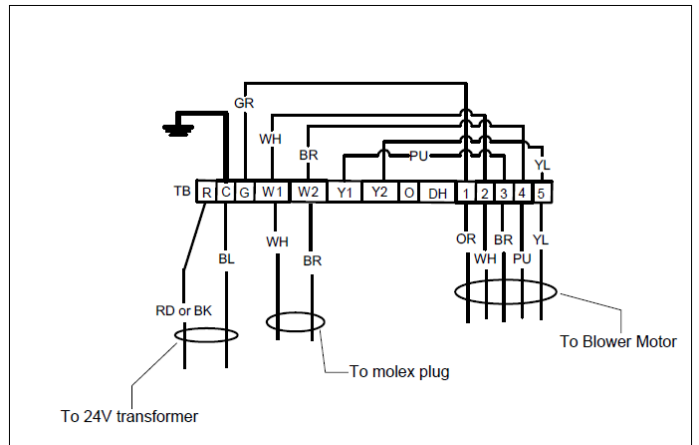

**HIGH STATIC APPLICATIONS WIRING  
FIGURE 15**

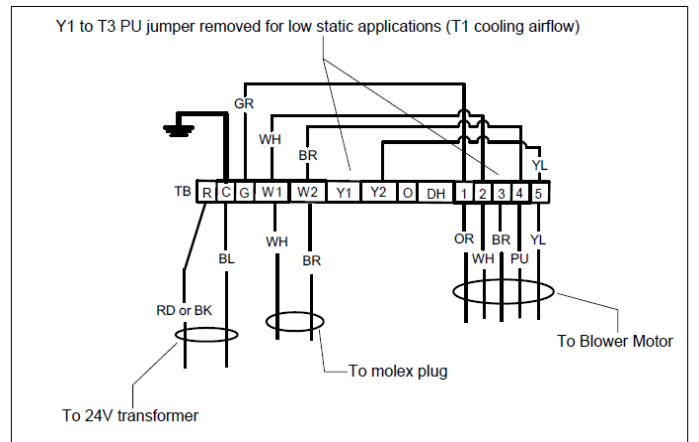

**LOW STATIC APPLICATIONS WIRING  
FIGURE 16**



	R	BL								OR	WH	BR	PU	YL
	R	C	G	W1	W2	Y1	Y2	O	DH	T1	T2	T3	T4	T5
High Static Applications			GR	WH	BR	PU	YL			GR	WH	PU	BR	YL
Low Static Applications			GR	WH	BR		YL			GR	WH		BR	YL

**TABLE 14**

### 13 Achieving 1.4% Low Leakage Rate

Ensure all the gaskets remain intact on all surfaces as shipped with the unit. These surfaces are areas between the upper tie plate and blower access panel, blower access and coil access panels, and between the coil access and filter access panels. Ensure upon installation, that the plastic breaker cover is sitting flush on the blower access panel and all access panels are flush with each other and the cabinet. With these requirements satisfied, the unit achieves less than 1.4% airflow leakage when tested in accordance with ASHRAE Standard 193.

### 14 Start-Up Procedure

 <b>WARNING</b>	
<b>HIGH VOLTAGE</b> DISCONNECT ALL POWER BEFORE SERVICING OR INSTALLING THIS UNIT. MULTIPLE POWER SOURCES MAY BE PRESENT. FAILURE TO DO SO MAY CAUSE PROPERTY DAMAGE, PERSONAL INJURY OR DEATH.	

- Prior to start-up, ensure that all electrical wires are properly sized and all connections are properly tightened.
- All panels must be in place and secured. For Air Tight application, gasket must be positioned at prescribed locations to achieve 1.4% leakage.
- Tubing must be leak free.
- Condensate line must be trapped and pitched to allow for drainage.
- Low voltage wiring is properly connected.
- Auxiliary drain is installed when necessary and pitched to allow for drainage.
- Unit is protected from vehicular or other physical damage.
- Return air is not obtained from, nor are there any return air duct joints that are unsealed in, areas where there may be objectionable odors, flammable vapors or products of combustion such as carbon monoxide (CO), which may cause serious personal injury or death.

### 15 Regular Maintenance

The only item required to be maintained on a regular basis by the user is the circulating air filter(s). Filter should be cleaned or replaced regularly, typically once per month. A certified service technician must perform all other services.

**IMPORTANT NOTE:** If thumb screws are used to access the filter, ensure the washer installed on the screw behind the access panel remains in place after re-installation.

## 16 Airflow Data

Model	Speed Tap	CFM @ STATIC PRESSURE (IN W.C.)								
		0.1	0.2	0.3	0.4	0.5	0.6	0.7	0.8	0.9
AMST24BU1400AA	T1	720	690	625	605	525	505	385	370	265
	T2	850	825	770	750	675	665	590	575	470
	T3	900	875	830	815	750	740	670	655	550
	T4	1030	1005	960	950	900	890	825	820	760
	T5	825	800	745	730	660	645	560	550	460
	T6	935	910	865	850	790	780	715	705	620
	T7	1100	1080	1035	1020	970	960	905	900	840
	T8	1045	1025	985	970	920	910	850	845	785
	T9	1215	1195	1155	1145	1105	1095	1045	1040	980
AMST30BU1400AA	T1	750	725	670	655	585	570	465	455	360
	T2	920	895	845	830	780	770	710	700	615
	T3	985	960	915	900	850	840	785	775	710
	T4	1185	1165	1125	1115	1070	1060	1015	1010	960
	T5	1070	1050	1005	995	945	935	890	885	830
	T6	620	585	515	485	375	310	260	245	145
	T7	840	815	760	745	685	670	590	580	480
	T8	855	830	780	765	705	695	625	615	515
	T9	995	970	925	910	860	850	800	790	730
AMST36BU1400AA	T1	750	725	670	655	585	570	465	455	360
	T2	920	895	845	830	780	770	710	700	615
	T3	985	960	915	900	850	840	785	775	710
	T4	1185	1165	1125	1115	1070	1060	1015	1010	960
	T5	1070	1050	1005	995	945	935	890	885	830
	T6	620	585	515	485	375	310	260	245	145
	T7	840	815	760	745	685	670	590	580	480
	T8	855	830	780	765	705	695	625	615	515
	T9	995	970	925	910	860	850	800	790	730
AMST36CU1400AA	T1	1120	1085	1020	1000	910	890	770	760	680
	T2	1285	1255	1190	1170	1100	1085	990	980	885
	T3	1430	1400	1345	1330	1260	1250	1175	1165	1065
	T4	1735	1710	1660	1645	1580	1570	1510	1500	1440
	T5	1830	1805	1755	1740	1685	1675	1605	1595	1525
	T6	1165	1130	1055	1035	960	940	825	815	715
	T7	1450	1425	1370	1355	1285	1275	1200	1190	1095
	T8	1070	1035	960	935	830	810	700	690	610
	T9	1735	1710	1660	1645	1580	1570	1510	1500	1440

Model	Speed Tap	CFM @ STATIC PRESSURE (IN W.C.)								
		0.1	0.2	0.3	0.4	0.5	0.6	0.7	0.8	0.9
AMST42CU1400AA	T1	1165	1140	1085	1065	990	975	895	880	765
	T2	1210	1185	1130	1110	1040	1025	950	935	830
	T3	1215	1190	1135	1120	1055	1040	960	945	835
	T4	1495	1470	1425	1415	1365	1355	1305	1295	1220
	T5	1435	1410	1360	1345	1295	1285	1220	1210	1140
	T6	1410	1385	1335	1325	1280	1270	1195	1185	1115
	T7	1495	1470	1425	1415	1365	1355	1305	1295	1220
	T8	1230	1205	1150	1135	1070	1060	990	975	850
	T9	1784	1743	1697	1652	1616	1576	1532	1486	1443
AMST48CU1400AA	T1	1635	1610	1560	1545	1480	1470	1400	1390	1315
	T2	1580	1550	1490	1470	1400	1390	1315	1305	1230
	T3	1635	1610	1560	1545	1480	1470	1400	1390	1315
	T4	1851	1810	1768	1733	1704	1662	1613	1486	1358
	T5	1820	1795	1750	1735	1680	1670	1605	1595	1525
	T6	1465	1435	1375	1355	1280	1265	1165	1155	1065
	T7	1725	1700	1650	1635	1570	1560	1495	1485	1420
	T8	1755	1730	1680	1665	1595	1585	1515	1505	1425
	T9	1325	1295	1230	1210	1130	1115	1025	1015	930
AMST48DU1400AA	T1	1425	1395	1335	1320	1250	1240	1165	1155	1070
	T2	1510	1480	1425	1410	1345	1335	1270	1260	1185
	T3	1605	1580	1525	1510	1450	1440	1375	1365	1300
	T4	1875	1855	1810	1795	1735	1725	1670	1665	1605
	T5	1755	1730	1680	1665	1605	1595	1535	1525	1465
	T6	1350	1320	1260	1245	1175	1160	1085	1075	980
	T7	1140	1105	1040	1020	935	915	805	790	685
	T8	1605	1580	1525	1510	1450	1440	1375	1365	1300
	T9	1605	1580	1525	1510	1450	1440	1375	1365	1300
AMST60DU1400AA	T1	1215	1175	1095	1070	975	950	790	780	700
	T6	1815	1785	1725	1710	1650	1640	1570	1560	1490
	T7	1360	1325	1250	1230	1145	1125	1010	990	850
	T8	2070	2045	1995	1980	1930	1920	1855	1845	1785
	T9	1970	1945	1895	1880	1815	1805	1740	1730	1660

**ASMT AIRFLOW DATA (CFM)  
TABLE 15**

**NOTE:**

1. Airflow data indicated is at 230V without air filter in place.
2. The chart is for information only. For satisfactory operation, external static pressure must not exceed value shown on rating plate.
3. Use the CFM adjustment factors of 0.98 for horizontal left and 0.96 for horizontal right & downflow orientations.
4. (AMST60DU1400\*\* ONLY) Refer to section '12.6 Speed Tap Adjustment' to obtain T1 airflow for low static applications.

## 17 Air Handler Low Voltage Connections

The following composite wiring diagrams detail various configurations in which the air handlers can be used. Examples include single-stage cooling and heat pump with single or two-stage electric heating. All these configurations can be applied with convenient connections to outdoor thermostat applications.

The following sections are detailed:

- Single-Stage Cooling
- Heat Pump

Each diagram details the connections between room thermostat and the air handlers, and the connections between the air handlers and the Condensing Unit (or Heat Pump) with optional connections to Outdoor Thermostats. For each configuration, refer to the explanation of the proper jumper(s) to remove for the corresponding blower speed that will result in the programmed fixed speed ECM motor.

**IMPORTANT: When matching the AMST air handlers to a single speed cooling or heat pump unit, remember to connect “Y” from the thermostat to the “Y2” on the low voltage terminal board.**

Any equivalent thermostat can be used in place of the manufacturer’s thermostat part number.

# 18 Wiring Diagrams

**WARNING**

**HIGH VOLTAGE! DISCONNECT ALL POWER BEFORE SERVICING.**

**MULTIPLE POWER SOURCES MAY BE PRESENT. FAILURE TO DO SO MAY CAUSE PROPERTY DAMAGE, PERSONAL INJURY OR DEATH.**

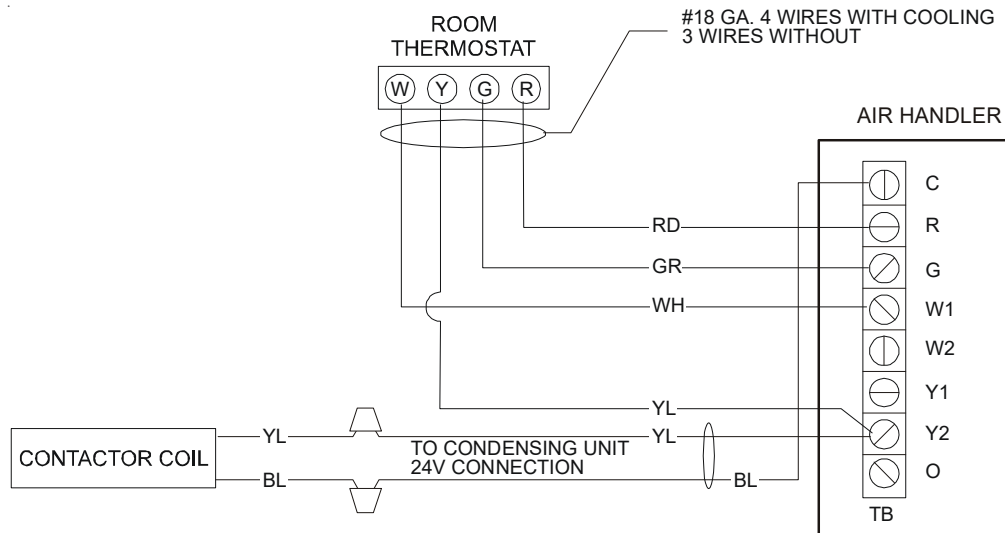

**COOLING UNIT WITH OPTIONAL HEAT KITS OF 10 kW AND BELOW**

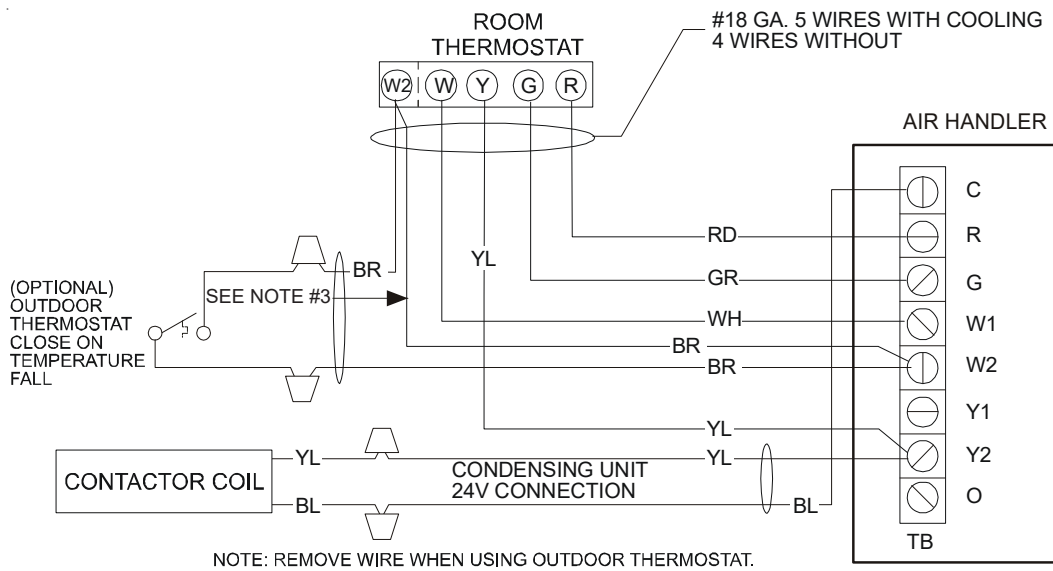

**COOLING UNIT WITH OPTIONAL HEAT KITS OF 15 kW AND ABOVE AND ROOM THERMOSTAT WITH TWO STAGES OF HEAT**

**NOTES:**

- 1) OUTDOOR THERMOSTAT (OT-1) SHOULD BE THE FIRST TO CLOSE AND THE LAST TO OPEN.
- 2) JUMPER W1 AND W2 TOGETHER IF OT-2 IS NOT USED.
- 3) REMOVE WIRE WHEN USING OUTDOOR THERMOSTAT.

**NOMENCLATURE:**

- OT - OUTDOOR THERMOSTAT (OPTIONAL)  
 EHR - EMERGENCY HEAT RELAY (OPTIONAL)

**COLOR CODES**

- RD - RED  
 YL - YELLOW  
 BL - BLUE  
 BR - BROWN  
 OR - ORANGE  
 WH - WHITE

Wiring is subject to change. Always refer to the wiring diagram on the unit for the most up-to-date wiring.

**WARNING** HIGH VOLTAGE! DISCONNECT ALL POWER BEFORE SERVICING. MULTIPLE POWER SOURCES MAY BE PRESENT. FAILURE TO DO SO MAY CAUSE PROPERTY DAMAGE, PERSONAL INJURY OR DEATH.

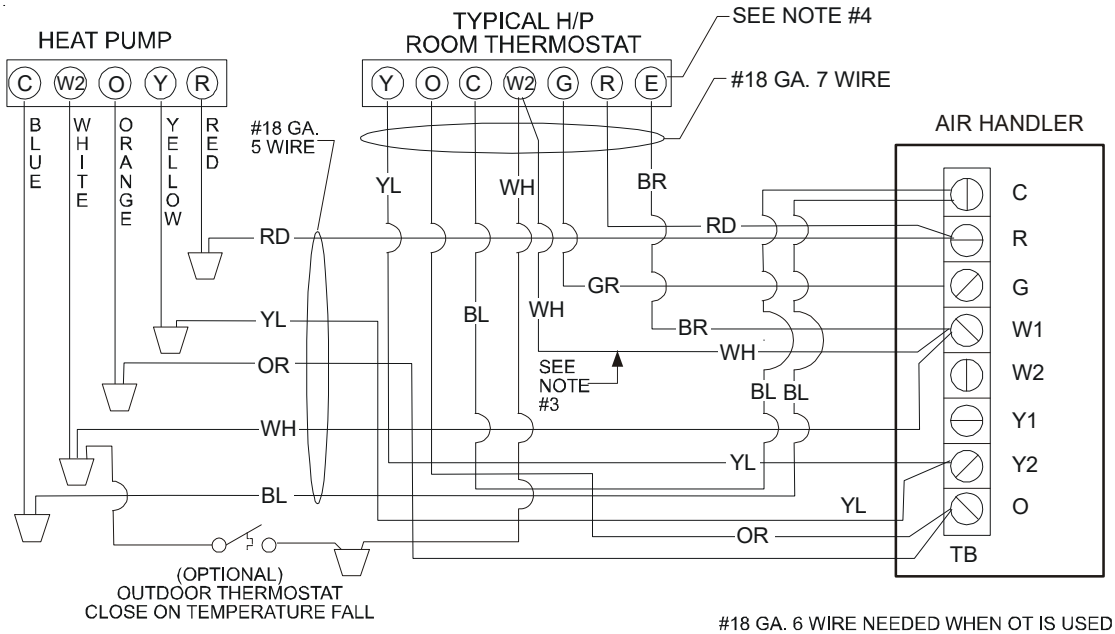

**HEAT PUMP UNIT WITH OPTIONAL HEAT KITS OF 10 kW AND BELOW**

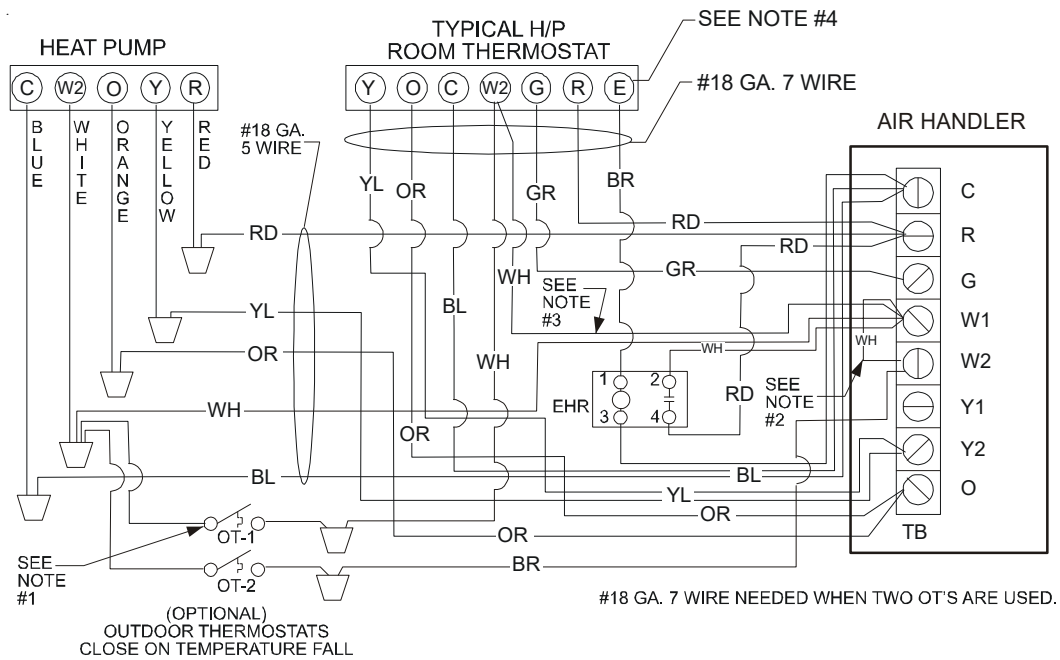

**HEAT PUMP UNIT WITH OPTIONAL HEAT KITS OF 15 kW AND ABOVE**

NOTES:

- 1) OUTDOOR THERMOSTAT (OT-1) SHOULD BE THE FIRST TO CLOSE AND THE LAST TO OPEN.
- 2) JUMPER W1 AND W2 TOGETHER IF OT-2 IS NOT USED.
- 3) REMOVE WIRE WHEN USING OUTDOOR THERMOSTAT.
- 4) E TERMINAL MAY NOT BE APPLICABLE FOR SOME THERMOSTATS

NOMENCLATURE:

- OT - OUTDOOR THERMOSTAT (OPTIONAL)  
 EHR - EMERGENCY HEAT RELAY (OPTIONAL)

COLOR CODES

- RD - RED  
 YL - YELLOW  
 BL - BLUE  
 BR - BROWN  
 OR - ORANGE  
 WH - WHITE

Wiring is subject to change. Always refer to the wiring diagram on the unit for the most up-to-date wiring.



**WARNING**

**HIGH VOLTAGE! DISCONNECT ALL POWER BEFORE SERVICING.**  
MULTIPLE POWER SOURCES MAY BE PRESENT. FAILURE TO DO SO  
MAY CAUSE PROPERTY DAMAGE, PERSONAL INJURY OR DEATH.



**AMST\*\*U1400\*\* (1.5T - 4T)**

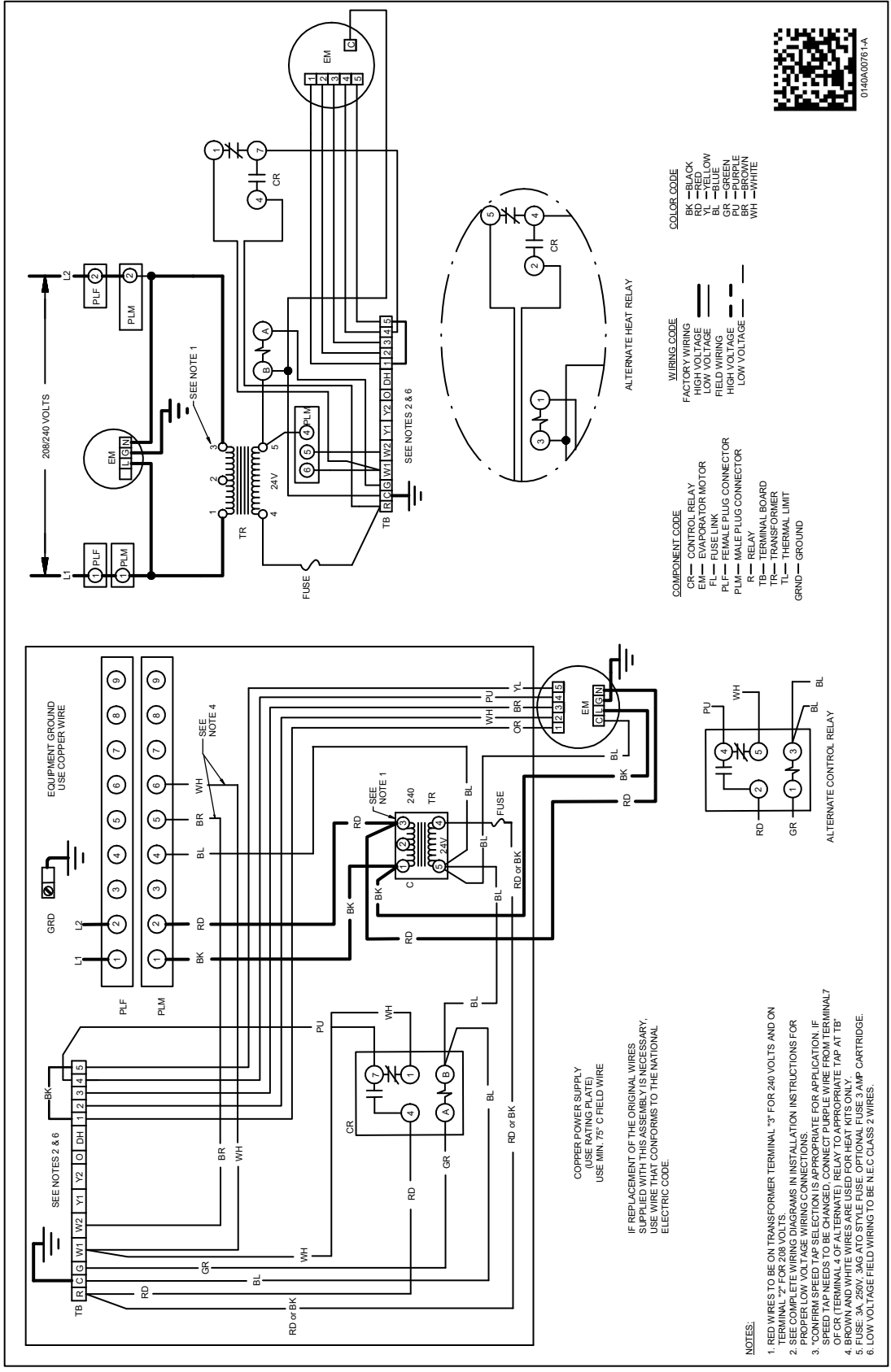

Wiring is subject to change. Always refer to the wiring diagram on the unit for the most up-to-date wiring.

**WARNING** HIGH VOLTAGE! DISCONNECT ALL POWER BEFORE SERVICING. MULTIPLE POWER SOURCES MAY BE PRESENT. FAILURE TO DO SO MAY CAUSE PROPERTY DAMAGE, PERSONAL INJURY OR DEATH.

AMST60DU1400\*\*

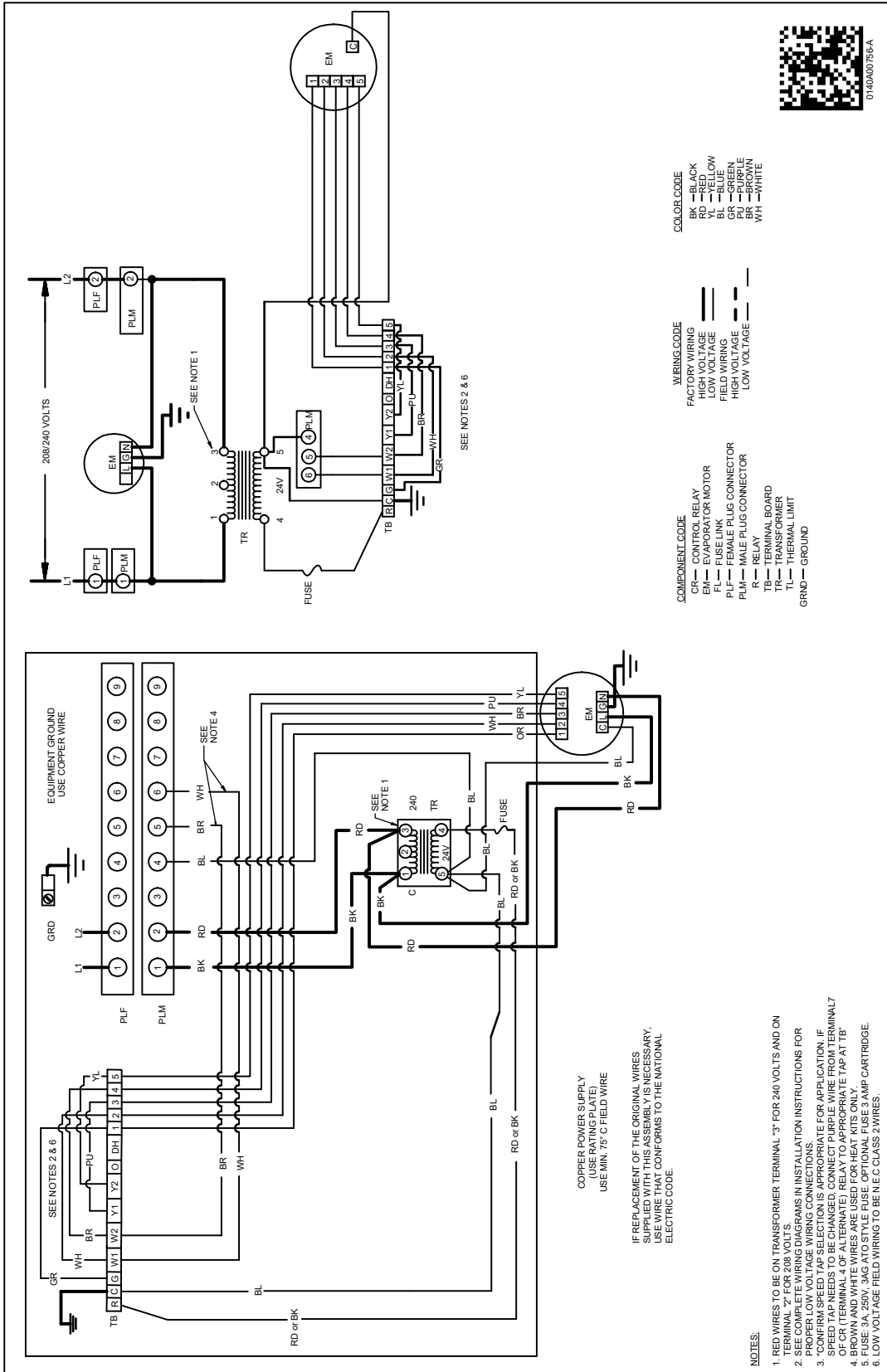

Wiring is subject to change. Always refer to the wiring diagram on the unit for the most up-to-date wiring.



**WARNING**

**HIGH VOLTAGE! DISCONNECT ALL POWER BEFORE SERVICING.**  
**MULTIPLE POWER SOURCES MAY BE PRESENT. FAILURE TO DO SO**  
**MAY CAUSE PROPERTY DAMAGE, PERSONAL INJURY OR DEATH.**



### 3-Phase Heat Kit

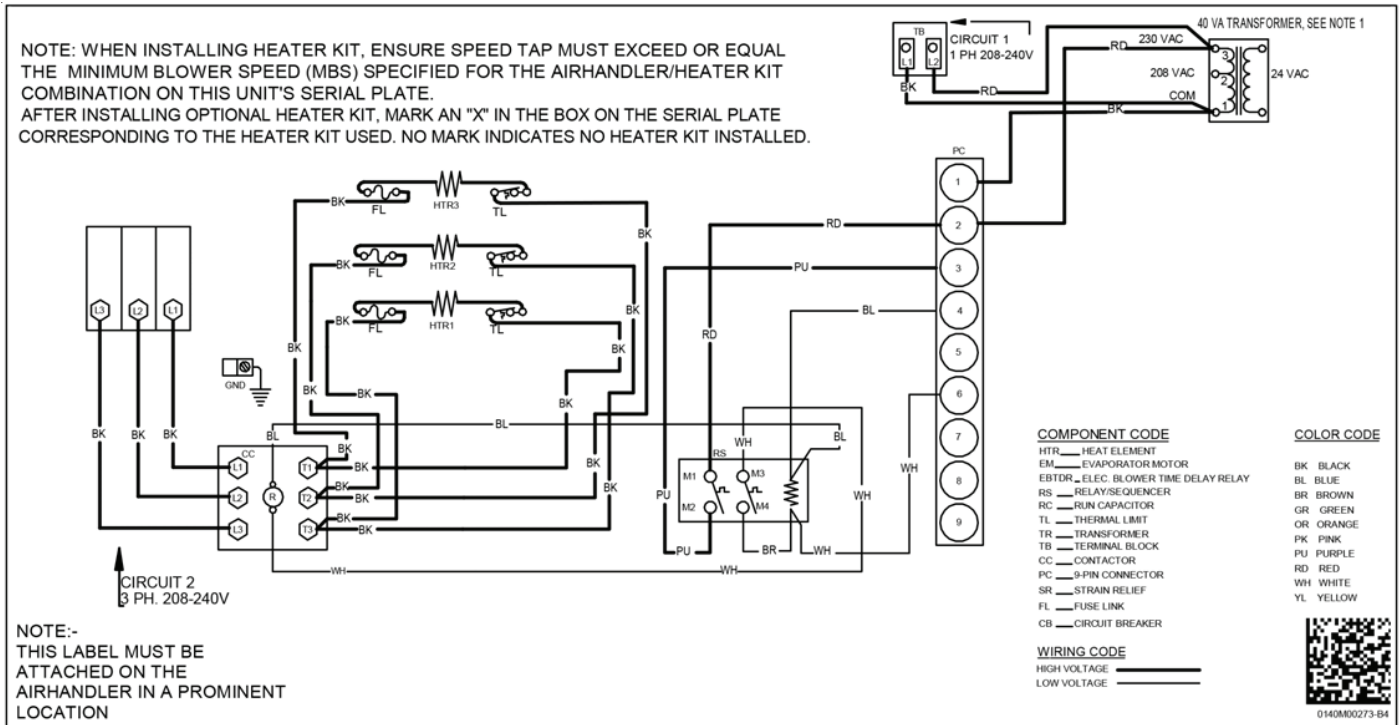

Wiring is subject to change. Always refer to the wiring diagram on the unit for the most up-to-date wiring.

## AIR HANDLER

### AIR HANDLER HOMEOWNER'S ROUTINE MAINTENANCE RECOMMENDATIONS

#### Replace or Clean Filter

**IMPORTANT NOTE: Never operate unit without a filter installed as dust and lint will build up on internal parts resulting in loss of efficiency, equipment damage and possible fire.**

An indoor air filter must be used with your comfort system. A properly maintained filter will keep the indoor coil of your comfort system clean. A dirty coil could cause poor operation and/or severe equipment damage.



Your air filter or filters could be located in your furnace, in a blower unit, or in "filter grilles" in your ceiling or walls. The installer of your air conditioner or heat pump can tell you where your filter(s) are, and how to clean or replace them.

Check your filter(s) at least once a month. When they are dirty, replace or clean as required. Disposable type filters should be replaced. Reusable type filters may be cleaned.

You may want to ask your dealer about high efficiency filters. High efficiency filters are available in both electronic and non-electronic types. These filters can do a better job of catching small airborne particles.

#### Motors

Indoor and outdoor fan motors are permanently lubricated and do not require additional oiling.

 <b>WARNING</b>	
<b>HIGH VOLTAGE</b> DISCONNECT ALL POWER BEFORE SERVICING OR INSTALLING THIS UNIT. MULTIPLE POWER SOURCES MAY BE PRESENT. FAILURE TO DO SO MAY CAUSE PROPERTY DAMAGE, PERSONAL INJURY OR DEATH.	

#### ALUMINUM INDOOR COIL CLEANING

(QUALIFIED SERVICER ONLY)

This unit is equipped with an aluminum tube evaporator coil. The safest way to clean the evaporator coil is to simply flush the coil with water. This cleaning practice remains as the recommended cleaning method for both copper tube and aluminum tube residential evaporator coils.

It has been determined that many coil cleaners and drain pan tablets contain corrosive chemicals that can be harmful to aluminum tube and fin evaporator coils. Even a one-time application of these corrosive chemicals can cause premature aluminum evaporator coil failure. Any cleaners that contain corrosive chemicals including, but not limited to, chlorine and hydroxides, should not be used.

An alternate cleaning method is to use one of the products listed in TP-109\* to clean the coils. The cleaners listed are the only agents deemed safe and approved for use to clean round tube aluminum coils. TP-109 is also available on the web site in Partner Link > Service Toolkit.

**NOTE: Ensure coils are rinsed well after use of any chemical cleaners.**

 <b>CAUTION</b>
<b>TO AVOID THE RISK OF EQUIPMENT DAMAGE OR FIRE, INSTALL THE SAME AMPERAGE BREAKER OR FUSE AS YOU ARE REPLACING. IF THE CIRCUIT BREAKER OR DUSE SHOULD OPEN AGAIN WITHIN THIRTY DAYS, CONTACT A QUALIFIED SERVICER TO CORRECT THE PROBLEM. IF YOU REPEATEDLY RESET THE BREAKER OR REPLACE THE FUSE WITHOUT HAVING THE PROBLEM CORRECTED, YOU RUN THE RISK OF SEVERE EQUIPMENT DAMAGE.</b>

#### BEFORE YOU CALL YOUR SERVICER

- Check the thermostat to confirm that it is properly set.
- Wait 15 minutes. Some devices in the outdoor unit or in programmable thermostats will prevent compressor operation for awhile, and then reset automatically. Also, some power companies will install devices which shut off air conditioners for several minutes on hot days. If you wait several minutes, the unit may begin operation on its own.
- Check the electrical panel for tripped circuit breakers or failed fuses. Reset the circuit breakers or replace fuses as necessary.
- Check the disconnect switch near the indoor furnace or blower to confirm that it is closed.
- Check for obstructions on the outdoor unit. Confirm that it has not been covered on the sides or the top. Remove any obstruction that can be safely removed. If the unit is covered with dirt or debris, call a qualified servicer to clean it.
- Check for blockage of the indoor air inlets and outlets. Confirm that they are open and have not been blocked by objects (rugs, curtains or furniture).
- Check the filter. If it is dirty, clean or replace it.
- Listen for any unusual noise(s), other than normal operating noise, that might be coming from the outdoor unit. If you hear unusual noise(s) coming from the unit, call a qualified servicer.



**THIS PAGE IS INTENTIONALLY LEFT BLANK**

### CUSTOMER FEEDBACK

We are very interested in all product comments.  
Please fill out the feedback form on one of the following links:  
Daikin Products: (<https://daikincomfort.com/contact-us>)  
Goodman® Brand Products: (<http://www.goodmanmfg.com/about/contact-us>).  
Amana® Brand Products: (<http://www.amana-hac.com/about-us/contact-us>).  
You can also scan the QR code on the right for the product brand you purchased to be directed to the feedback page.



DAIKIN



GOODMAN® BRAND



AMANA® BRAND

### PRODUCT REGISTRATION

Thank you for your recent purchase. Though not required to get the protection of the standard warranty, registering your product is a relatively short process, and entitles you to additional warranty protection, except that failure by California and Quebec residents to register their product does not diminish their warranty rights.

For Product Registration, please register as follows:  
Daikin Products: (<https://daikincomfort.com/owner-support/product-registration>).  
Goodman® Brand products: (<https://www.goodmanmfg.com/product-registration>).  
Amana® Brand products: (<http://www.amana-hac.com/product-registration>).  
You can also scan the QR code on the right for the product brand you purchased to be directed to the Product Registration page.



DAIKIN



GOODMAN® BRAND



AMANA® BRAND